

**HUTCHISON'S**

# PAEDIATRICS

2<sup>nd</sup> Edition



Krishna M Goel  
Devendra K Gupta

Foreword  
Terence Stephenson

**JAYPEE**

# **HUTCHISON'S PAEDIATRICS**



# HUTCHISON'S PAEDIATRICS

***Second Edition***

*Edited by*

**Krishna M Goel**

MD DCH FRCP (Lond, Edin and Glas) Hon FRCPCH  
*Formerly* Honorary Senior Lecturer of Child Health  
University of Glasgow and Consultant Paediatrician  
at the Royal Hospital for Sick Children  
Yorkhill, Glasgow, Scotland, UK

**Devendra K Gupta**

MS MCh FAMS (Hon) FCSS FRCS (Edin) FRCS (Glas) FAMS (Rom) DSc (Honoris Causa)  
Vice Chancellor  
Chhatrapati Shahuji Maharaj Medical University  
Lucknow, Uttar Pradesh, India

*Foreword*

**Professor Terence Stephenson**



**JAYPEE BROTHERS MEDICAL PUBLISHERS (P) LTD**

**New Delhi • Panama City • London**



**Jaypee Brothers Medical Publishers (P) Ltd.**

### **Headquarter**

Jaypee Brothers Medical Publishers (P) Ltd  
4838/24, Ansari Road, Daryaganj  
New Delhi 110 002, India  
Phone: +91-11-43574357  
Fax: +91-11-43574314  
**Email: [jaypee@jaypeebrothers.com](mailto:jaypee@jaypeebrothers.com)**

### **Overseas Offices**

J.P. Medical Ltd.  
83 Victoria Street, London  
SW1H 0HW (UK)  
Phone: +44-2031708910  
Fax: +02-03-0086180  
**Email: [info@jpmepub.com](mailto:info@jpmepub.com)**

Jaypee-Highlights medical publishers Inc.  
City of Knowledge, Bld. 237, Clayton  
Panama City, Panama  
Phone: + 507-301-0496  
Fax: + 507-301-0499  
**Email: [cservice@jphmedical.com](mailto:cservice@jphmedical.com)**

Website: [www.jaypeebrothers.com](http://www.jaypeebrothers.com)  
Website: [www.jaypeedigital.com](http://www.jaypeedigital.com)

© 2012, Jaypee Brothers Medical Publishers

All rights reserved. No part of this book may be reproduced in any form or by any means without the prior permission of the publisher.

**Inquiries for bulk sales may be solicited at:** [jaypee@jaypeebrothers.com](mailto:jaypee@jaypeebrothers.com)

This book has been published in good faith that the contents provided by the contributors contained herein are original, and is intended for educational purposes only. While every effort is made to ensure accuracy of information, the publisher and the editors specifically disclaim any damage, liability, or loss incurred, directly or indirectly, from the use or application of any of the contents of this work. If not specifically stated, all figures and tables are courtesy of the editors. Where appropriate, the readers should consult with a specialist or contact the manufacturer of the drug or device.

### ***Hutchison's Paediatrics***

*First Edition:* 2009

*Second Edition:* **2012**

ISBN : 978-93-5025-771-5

*Printed at*

# CONTRIBUTORS

## **Alastair Turner**

BSc Med Sci MBChB MRCPCH  
Consultant Paediatric Intensive Care  
Honorary Senior Clinical Lecturer  
University of Glasgow  
Royal Hospital for Sick Children  
Glasgow, Scotland, UK

## **Alison M Cairns**

MSc BDS MFDS FRCS (Edin) M Paed Dent (RCPSG)  
Clinical Lecturer in Paediatric Dentistry  
University of Glasgow Dental Hospital  
and School, Glasgow, Scotland, UK

## **Anne Margaret Devenny**

MBChB MRCP (UK) FRCPC  
Paediatric Respiratory Consultant  
Royal Hospital for Sick Children  
Glasgow, Scotland, UK

## **Beena Koshy**

MBBS MD (Paed) PDFDP  
Assistant Professor of Developmental  
Paediatrics, Christian Medical College  
Vellore, Tamil Nadu, India

## **Benjamin Joseph**

MS Orth MCh Orth  
Professor of Orthopaedics and Head of  
Paediatric Orthopaedic Service  
Kasturba Medical College  
Manipal 576104, Karnataka, India

## **Christina Halsey**

BM Bch BA (Hons) MRCP MRCPATH PhD  
Honorary Consultant Paediatric  
Haematologist and Scottish Senior  
Clinical Fellow  
Department of Paediatric Haematology  
Royal Hospital for Sick Children  
Glasgow, Scotland, UK

## **Chikkanayakanahali Manjunatha**

MD (Paed) DCH DNB (Paed) MRCP (UK) FRCPC  
Consultant Neonatologist  
Wishaw General Hospital  
50, Netherton Road  
Wishaw ML2 0DP  
Lanarkshire, Scotland, UK

## **Craig Williams**

MD FRCP FRCPath  
Consultant Microbiologist  
Royal Hospital for Sick Children  
Glasgow, Scotland, UK

## **David James**

MBChB Dip Ed DCH DPM FRCPsych FRCP (Glas)  
Retired Child Psychiatrist formerly  
at Department of Child and Family  
Psychiatry  
Royal Hospital for Sick Children  
Glasgow, Scotland, UK

## **Devendra K Gupta**

MS MCh FAMS (Hon) FCSS FRCS (Edin) FRCS (Glas)  
FAMS (Rom) DSc (Honoris Causa)  
Vice Chancellor  
Chhatrapati Shahuji Maharaj Medical  
University  
Lucknow, Uttar Pradesh, India

## **Elizabeth A Chalmers**

MBChB MD MRCP (UK) FRCPath  
Consultant Paediatric Haematologist  
Royal Hospital for Sick Children  
Glasgow, Scotland, UK

## **James Wallace**

BSc MR PharmS FRCPC (Hon)  
Chief Pharmacist  
Yorkhill Hospitals  
Glasgow, Scotland, UK

## **Jean Herbison**

MBChB MRCP FRCPC DCCH MFFLM  
Consultant Paediatrician and Clinical  
Director for Child Protection Services  
Greater Glasgow and Clyde Health Board  
Child Protection Unit  
Royal Hospital for Sick Children  
Glasgow, Scotland, UK

## **Judy Ann John**

MD DipNB (PMR)  
Associate Professor  
Department of Physical Medicine and  
Rehabilitation  
Christian Medical College  
Vellore, Tamil Nadu, India

## **Jugesh Chhatwal**

MD DCH  
Professor and Head of Paediatrics  
Christian Medical College  
Ludhiana, Punjab, India

## **Khursheed F Moos**

MBBS (Lond) BDS (Lond) FRCS (Edin) FDS RCS (Eng  
and Edin) FDS RCPS (Glasg) FRCPS (Glasg) Honorary  
FCPS (Pakistan) Honorary OBE

Honorary Professor of Oral and  
Maxillofacial Surgery—Glasgow  
University, Consultant Oral and  
Maxillofacial Surgeon—West of Scotland  
Plastic and Maxillofacial Unit  
Canniesburn Hospital  
Glasgow Civilian Consultant  
to the Royal Navy  
Scotland, UK

## **Kirsteen J Thompson**

MSc FRCS (Edin)  
Consultant Ophthalmologist  
Inverclyde Royal Hospital  
Greenock, Scotland, UK

## **Krishna M Goel**

MD DCH FRCP (Lond, Edin & Glas) Hon FRCPC  
Formerly Honorary Senior Lecturer of  
Child Health, University of Glasgow and  
Consultant Paediatrician  
Royal Hospital for Sick Children  
Glasgow, Scotland, UK

## **Louis Low**

MBChB MRCP (UK) FRCP (Lond, Edin & Glas)  
FRCPC  
Honorary Clinical Professor in Paediatrics  
Department of Paediatrics  
and Adolescent Medicine  
The University of Hong Kong  
Queen Mary Hospital  
Pokfulam, Hong Kong

## **Lydia Edward Raj**

MSOT  
Reader (In-charge OT Education)  
Department of Physical Medicine  
and Rehabilitation  
Christian Medical College  
Vellore, Tamil Nadu, India

## **Margo L Whiteford**

BSc FRCP (Glasgow)  
Consultant Clinical Geneticist  
Ferguson-Smith Centre for Clinical Genetics  
Yorkhill Hospital  
Glasgow, Scotland, UK

## **Mary Mealyea**

MBChB Diploma in Dermatology  
Associate Specialist in Paediatric  
Dermatology  
Royal Hospital for Sick Children  
Glasgow, Scotland, UK

**Maya Mary Thomas**

MBBS DCH MD (Paeds) DM (Neuro)  
Associate Professor and Paediatric  
Neurologist, Department of Neurological  
Sciences, Christian Medical College  
Vellore, Tamil Nadu, India

**Michael Morton**

MPhil MA MBChB FRCPsych FRCPCH  
Consultant Child & Adolescent Psychiatrist  
In-patient & Liaison Child & Adolescent  
Psychiatry with Neuropsychiatry  
Department of Child & Family Psychiatry  
Royal Hospital for Sick Children  
Glasgow, Scotland, UK

**NV Doraiswamy**

MS FRCS (Edin & Glas) FICS FISS FFAEM FRCPCH  
Consultant Surgeon (Retd)  
Royal Hospital for Sick Children  
Glasgow, Scotland, UK

**Paul Galea**

MD DCH FRCP (Glas) FRCPCH  
Consultant Paediatrician  
Royal Hospital for Sick Children  
Glasgow, Scotland, UK

**Peter Galloway**

BSc DCH FRCP (Edin & Glas) FRCPPath  
Consultant Medical Biochemist  
Royal Hospital for Sick Children,  
Glasgow, Scotland, UK

**Phyllis Kilbourn**

International Director  
Crisis Care Training International  
International Office, PO Box 517  
Fort Mill, South Carolina, USA

**Prabhakar D Moses**

MBBS MD (Paed) MRCP (UK) FRCP (Edin) FCAMS  
Professor and Head of Paediatrics Unit 111  
Christian Medical College  
Vellore, Tamil Nadu, India

**Rajeev Srivastava**

MBBS MS (Orth) FRCS (G) FRC Path  
Consultant Medical Biochemist  
Royal Hospital for Sick Children  
Glasgow, Scotland, UK

**Richard Welbury**

BDS (Hons) MBBS PhD FDSRCS FDSRCPs  
FRCPCH  
Professor of Paediatric Dentistry  
University of Glasgow Dental Hospital  
and School  
Glasgow, Scotland, UK

**Robert Carachi**

MD PhD FRCS (Glas & Eng) FEBPS  
Professor of Surgical Paediatrics  
University of Glasgow  
Royal Hospital for Sick Children  
Glasgow, Scotland, UK

**Rosemary Anne Hague**

MD MRCP (UK) FRCPCH  
Consultant Paediatric ID/Immunology  
Yorkhill NHS Trust  
Royal Hospital for Sick Children  
Glasgow, Scotland, UK

**Rosemary Sabatino**

Trainer and Educator  
Crisis Care Training International  
International Office  
PO Box 517, Fort Mill  
South Carolina, USA

**Samuel E Ibhanebor**

FWACP FMCPaed FRCPCH FRCP (Glasg)  
Consultant Neonatologist  
Wishaw General Hospital  
50, Netherton Road  
Wishaw ML2 0DP  
Lanarkshire, Scotland, UK

**Sandra J Butler**

BSc (Hons) MBChB MRCPCH FRCR  
Consultant Paediatric Radiologist  
Royal Hospital for Sick Children  
Glasgow, Scotland, UK

**Sanjay V Maroo**

MBChB M-Med FRCR  
Consultant Paediatric Radiologist  
Royal Hospital for Sick Children  
Glasgow, Scotland, UK

**Sarada David**

MS DO  
Professor and Head  
Department of Ophthalmology  
Christian Medical College  
Vellore, Tamil Nadu, India

**Shilpa Sharma**

MS MCh DNB PhD  
Associate Professor  
Paediatric Surgery  
416 Administration Block  
PGIMER, Dr RML Hospital  
Baba Kharg Singh Marg  
Connaught Place  
New Delhi, India

**Syed Rehan Ali**

MB DCH MRCP FRCP  
Assistant Professor and Consultant in  
Neonatal Medicine  
Director of Neonatal Services  
Department of Paediatrics and Child Health  
Aga Khan University Hospital  
Karachi, Pakistan

**Tahmeed Ahmed**

MBBS PhD  
Head, Nutrition Programme Scientist  
Clinical Sciences Division  
International Centre for Diarrhoeal  
Diseases Research, B  
Dhaka, Bangladesh

**Trevor Richens**

MBBS BSc (Hons) MRCP (Lond)  
Consultant Paediatric Cardiologist  
Royal Hospital for Sick Children  
Glasgow, Scotland, UK

**Zulfiqar Ahmed Bhutta**

MBBS FRCP FRCPCH FCPS PhD  
The Husein Lalji Dewraj  
Professor and Chairman  
Department of Pediatrics and Child Health  
The Aga Khan University and  
Medical Center  
Karachi, Pakistan

# FOREWORD

---

The world moves at a frightening pace and sometimes I hear a view expressed that textbooks are a thing of the past. We should be able to get all the information we need from the Internet and what is more, it is argued, it is more likely to be up-to-date. I disagree. I think there is still a place for a well written, comprehensive textbook and I use the books on my shelves most days. The reader can have confidence in the contents if they are familiar with the authors and editors and this is an advantage that has to be set against the potential benefits of electronic information. Whilst the Internet is likely to be updated in real time, there is very little peer review or filtering of the information placed on it and the reader can rarely be sure of the provenance of the opinions expressed.

I am delighted that Krishna M Goel and Devendra K Gupta have produced the second edition of their marvellous textbook *Hutchison's Paediatrics*. This will be of great value to all those who use it, whether students, or those preparing for professional examinations, or simply (like myself) keeping up-to-date or finding the answers to difficult clinical problems in daily practice.

James Holmes Hutchison graduated at the University of Glasgow. He served in the Second World War rising to the rank of Lieutenant Colonel and was awarded an Order of the British Empire in 1945. He returned to the Hospital for Sick Children in Glasgow and subsequently became the Samson Gemmel Professor in Paediatrics. He was President of the Royal College of Physicians and Surgeons of Glasgow, then became President of the British Paediatric Association and then served as Dean of the Faculty of Medicine in Glasgow. Following his time in Glasgow, he was appointed Professor of Paediatrics at the University of Hong Kong.

I hope you enjoy reading *Hutchison's Paediatrics* in this new edition as much as I have.



**Professor Terence Stephenson**

DM FRCP (Lon) FRCPCH

President

Royal College of Paediatrics and Child Health

University of Nottingham

Nottingham, UK





# PREFACE TO THE SECOND EDITION

---

The patterns of childhood disease throughout the world are changing with advancing knowledge, altering standards of living, lifestyle and rising levels of medical care. The origins of physical and mental health and disease lie predominantly in the early development of the child. Most of the abnormalities affecting the health and behaviour of children are determined prenatally or in the first few years of life by genetic and environmental factors. The authors have summarised the current knowledge of causation and have indicated where health education and prevention might reduce the burden of childhood ill health.

The more diverse authorship of chapters in this second edition reflects the growing dependence upon cooperative interests of colleagues in paediatrics. In clinical practice, such collaborative work can only be accomplished within a large hospital or a unit devoted to children. Both editors have been fortunate to work in such an environment and believe that the highest standards of paediatric practice can only be attained in such circumstances. In this, the second edition, we welcome ten new contributors. In this book we seek to provide practical advice about the diagnosis, investigation and management of the full spectrum of childhood disorders, both medical and surgical. We have tried to indicate, and where appropriate to describe, techniques and laboratory investigations which are necessary for advanced diagnosis and up-to-date therapy. Attention is directed to the special problems which arise in the developing countries. The need for such a text has been confirmed by the success of the first edition, published in 2009. As is often the case, space limitation demands some selectivity of content. It is intended in a true apprenticeship fashion of teaching to provide a manageable, readable and practical account of clinical paediatrics for medical undergraduates, for postgraduates specialising in paediatrics and for general practitioners whose daily work is concerned with care of children in health and sickness. Knowledge within the field of paediatrics continues to increase exponentially. Accordingly, many chapters in this edition were completely revised, updated and extended with an additional four chapters. Many figures illustrating salient concepts summarising clinical findings and treatment results have been added.

We are especially grateful to the parents and to the many children and their families who contributed to our knowledge and understanding of paediatrics and willingly gave permission to reproduce photographs of their children. A book such as this cannot be written without reproducing material reported in the medical literature. We acknowledge here, with gratitude, the permission granted free of charge by individual publishers to reproduce material for which they hold the copyright.

We particularly wish to thank the Hutchison family for allowing us to use the name of the late Professor James Holmes Hutchison, the author of 'Practical Paediatric Problems' to enable us to title this book *Hutchison's Paediatrics*. Even today, Hutchison's name is highly respected in the paediatric world.

Finally, we are grateful to the various contributors to this second edition for their cooperation in its production.

**Krishna M Goel**  
**Devendra K Gupta**



# PREFACE TO THE FIRST EDITION

---

The patterns of childhood disease throughout the world are changing with advancing knowledge, altering standards of living, lifestyle and rising levels of medical care. The origins of physical and mental health and disease lie predominantly in the early development of the child. Most of the abnormalities affecting the health and behaviour of children are determined prenatally or in the first few years of life by genetic and environmental factors. The range of contributors indicates that they are all experts in their particular fields. The authors have summarised the current knowledge of causation and have indicated where health education and prevention might reduce the burden of childhood ill health. We seek in this book to provide practical advice about the diagnosis, investigation and management of the full spectrum of childhood disorders, both medical and surgical. We have tried to indicate and where appropriate to describe, techniques and laboratory investigations which are necessary for advanced diagnosis and up-to-date therapy. Attention is directed to the special problems which arise in the developing countries.

It is intended in a true apprenticeship fashion of pedagogy to provide a manageable, readable and practical account of clinical paediatrics for medical undergraduates, for postgraduates specialising in paediatrics and for general practitioners whose daily work is concerned with care of children in health and sickness. The authors had to be selective in deciding what to exclude in order to keep the book manageable and practical.

We would like to express our immense gratitude to our colleagues who have provided us with help and advice in writing this book. The willingness with which they gave us their time in spite of many other commitments leaves us permanently in their debt.

We are especially grateful to the parents and to the many children and their families who contributed to our knowledge and understanding of paediatrics and willingly gave permission to reproduce photographs of their children. Also a book such as this cannot be written without reproducing material reported in the medical literature. We acknowledge here with gratitude the permission granted free of charge by individual publishers to reproduce material for which they hold the copyright.

Our deepest thanks go to Professor Forrester Cockburn, Professor Dan Young and Professor Robert Carachi, who most kindly passed on to us their rights of the book entitled 'Children's Medicine and Surgery' from which some material has been used.

We particularly wish to thank the Hutchison family for allowing us to use the name of the late Professor James Holmes Hutchison, the author of 'Practical Paediatric Problems' to enable us to title this book *Hutchison's Paediatrics*. Even today Hutchison's name is highly respected in the paediatric world.

Finally, we would like to express our thanks to Jean Hyslop, Medical Artist, who created the line drawings and art work and helped to integrate the text with the illustrations.

**Krishna M Goel**  
**Devendra K Gupta**



# CONTENTS

## 1. Paediatric History and Examination

*Krishna M Goel, Robert Carachi*

- The history 1
- Clinical manifestations of disease 1
- History and documentation 2
- Introduction 4
- History of present complaint 4
- Past medical history 5
- Mother's pregnancy, labour, delivery and the neonatal period 5
- Dietary history 5
- Developmental history 5
- Family and social history 5
- Physical examination 6
- A guide to examination of a child-patient 12
- Respiratory system 13
- Cardiovascular system 14
- Percussion of the heart is not normally undertaken in children 14
- Gastrointestinal system 14
- Nervous system 14
- Cranial nerve 14
- Locomotor system 15
- Developmental assessment 15

## 2. Growth and Development

*Louis Low*

- Normal growth 18
- Assessment and monitoring of growth 19
- The growth hormone: IGF 1 axis 21
- Genetics of stature 21
- Puberty 21
- Child development 23
- Gross motor development 23
- Fine motor development in early childhood 24
- Language and speech development in childhood 24
- Social development 25
- Emotional and cognitive development 26
- Development assessment 26

## 3. Neonatal Paediatrics

*Samuel E Ibhanebehbor, Chikkanayakanahali Manjunatha, Syed Rehan Ali, Zulfiqar Ahmed Bhutta*

- Introduction 28
- Neonatal resuscitation 28
- Hypoxic ischaemic encephalopathy 30
- Whole baby hypothermia 31
- Routine newborn examination 32
- Perinatal injuries 33
- Meconium aspiration syndrome 34
- Transient tachypnoea of the newborn (or 'wet lung') 34

1

- Cyanotic congenital heart disease 34
- Neonatal jaundice 35
- Intrauterine growth restriction or retardation 37
- Preterm 37
- Chromosomal abnormalities 41
- Haematology 42
- Inborn errors of metabolism 43
- Multiple gestation 46
- Maternal substance and alcohol abuse 47
- Neonatal sepsis 47
- Neonatal procedures 48
- Vaccination and weaning 48
- Nutrition 48
- Discharge planning 50
- Withholding and withdrawal of treatment 50
- **Newborn health in developing countries** 50
- Introduction 50
- Birth asphyxia 51
- Neonatal infections 52
- Term IUGR/LBW 55
- Congenital malformations and inherited disorders 56
- Prematurity 57
- Respiratory distress syndrome 57

## 4. Paediatric Genetics

59

*Margo L Whiteford*

- Introduction 59
- History 59
- Patterns of inheritance 60
- Investigations 63

## 5. Nutrition

75

*Tahmeed Ahmed, Zulfiqar Ahmed Bhutta, Krishna M Goel*

- **Protein-energy malnutrition and micronutrient deficiencies in childhood** 75
- Protein-energy malnutrition 75
- Causes of PEM 75
- Classification of PEM 75
- Management of mild or moderate malnutrition 77
- Facility-based management of severe acute malnutrition 77
- Phases of management of severe acute malnutrition 78
- Treatment of complications 81
- Community-based management of severe acute malnutrition 83
- **Other disturbances of nutrition** 83
- Vitamin D deficiency 89
- Vitamin D metabolism 89
- Vitamin C (ascorbic acid) deficiency 92
- Vitamin B deficiencies 93
- Vitamin E (tocopherol) deficiency 97
- Vitamin K deficiency 97
- Biotin and pantothenic acid 97

**6. Respiratory Disorders***Anne Margaret Devenny*

- Introduction 100
- History and examination 100
- Respiratory investigations 100
- Examination 101
- The respiratory tract in children 102
- Other congenital lung abnormalities 104
- Acquired abnormalities 105
- Acquired lower respiratory tract problems 105
- Aspiration pneumonia 108
- Asthma 108
- Bronchiectasis 112
- Cystic fibrosis 112
- Pulmonary tuberculosis 116
- Bronchiolitis obliterans 116
- Pneumothorax 116
- Sleep disordered breathing in children 117
- Obstructive sleep apnoea 117
- Neuromuscular causes of sleep disordered breathing 118
- Sudden infant death syndrome 118
- Chest injury 118
- Foreign body inhalation 118
- Questions and answers 119

**7. Gastroenterology and Hepatology***Krishna M Goel, Robert Carachi, Zulfiqar Ahmed Bhutta*

- **Gastrointestinal and Liver Disease**
- Introduction 121
- Gastro-oesophageal reflux disease (GORD) 121
- Gastrointestinal haemorrhage 122
- Oesophageal varices 123
- Peptic ulcer 123
- Blood per rectum 124
- Rectal prolapse 124
- Intestinal polyps 125
- Infantile colic 125
- Recurrent abdominal pain in children 125
- Appendicitis 125
- Foreign bodies 128
- Necrotising enterocolitis 129
- Toddler's diarrhoea 130
- Infectious diarrhoea in childhood 130
- Fermentative diarrhoea (disaccharide intolerance) 130
- Parasitic intestinal infection 131
- Nematodes 131
- Cestodes 133
- Inflammatory bowel disease 134
- Coeliac disease (gluten-sensitive enteropathy) 137
- Cystic fibrosis 139
- Idiopathic childhood constipation 141
- Protein-losing enteropathy 143
- Wilson's disease (hepatolenticular degeneration) 144
- Jaundice 145
- Viral infections of the liver 145

100

- Cirrhosis of the liver 147
- Pancreas 148
- Juvenile tropical pancreatitis 148
- Liver transplantation 148
- **Infectious diarrhoea in childhood** 149

**8. Paediatric Cardiology**

157

*Trevor Richens*

- Introduction 157
- General principles of diagnosis 157
- Examination 157
- **Congenital heart abnormalities** 162
- Acyanotic congenital heart disease 162
- Cyanotic congenital heart disease 169
- Acquired heart disease 176
- Heart rhythm abnormalities 181
- Case studies 183

**9. Care of the Paediatric Surgical Patient**

186

*Shilpa Sharma, Devendra K Gupta*

- **Basic paediatric surgery** 186
- Introduction 186
- History taking of paediatric surgical patients 186
- Clinical examination 187
- Pre- and postoperative care 188
- Fluid and electrolyte management 189
- Blood transfusion 191
- Summary 192
- **Paediatric trauma and burns** 192
- Paediatric trauma 192
- Physiological parameters 193
- Approach to the injured child 193
- Emergency treatment 195
- Child abuse 197
- Burns 197
- Emergency room management 200
- Surgical management of the burn wound 202
- Complications and rehabilitation 203
- Long-term complications 204

**10. Neonatal Surgery**

205

*Devendra K Gupta, Shilpa Sharma*

- Congenital diaphragmatic hernia 205
- Oesophageal atresia 206
- Infantile hypertrophic pyloric stenosis 209
- Malrotation 210
- Hirschsprung's disease 212
- Anorectal malformations 214
- Neural tube defects 220
- Hydrocephalus 223

**11. General Paediatric Surgery**

228

*Devendra K Gupta, Shilpa Sharma*

- Cleft lip and palate 228
- Branchial arch anomalies 230
- Thyroglossal cyst 233
- Umbilical hernia 234
- Intussusception 235

- Surgical jaundice in children 235  
 Choledochal cyst 238  
 Inguinal hernia and hydrocoele 241
- 12. Paediatric Urology 244**  
*Devendra K Gupta, Shilpa Sharma*
- Hydronephrosis 244  
 Exstrophy of bladder 247  
 Undescended testis or cryptorchidism 249  
 Phimosis 253  
 Paediatric intersex disorders 253
- 13. Paediatric Oncology 258**  
*Devendra K Gupta, Shilpa Sharma, Robert Carachi*
- Wilms' tumour 258  
 Neuroblastoma 261  
 Rhabdomyosarcoma 265  
 Hepatoblastoma 268  
 Hepatocellular carcinoma 270  
 Germ cell tumours 271
- 14. Dermatology 279**  
*Mary Mealyea*
- Introduction 279  
 Common terms used 279  
 History 280  
 Vascular anomalies 280  
 Disorders of pigmentation 283  
 Café au lait macules 284  
 Dermal melanocytosis 285  
 Epidermal naevi 285  
 Blistering disorders 286
- 15. Haematological Disorders 299**  
*Krishna M Goel*
- Haematopoiesis 299  
 The normal blood picture in infancy 299  
 Iron deficiency or nutritional anaemia of infancy 300  
 The megaloblastic anaemias (folate deficiency, vitamin B<sub>12</sub> deficiency) 302  
 The haemolytic anaemias 303  
 Autoimmune haemolytic anaemia 309  
 Paroxysmal nocturnal haemoglobinuria 310  
 Microangiopathic haemolytic anaemia 310  
 Aplastic and hypoplastic anaemia 310  
 Congenital hypoplastic anaemia (Blackfan Diamond anaemia) 310  
 Fanconi-type familial aplastic anaemia 311  
 Acquired hypoplastic anaemia 312  
 Albers-Schönberg disease (osteopetrosis, marble bones) 312  
 The thrombocytopaenic purpuras 312  
 Idiopathic thrombocytopaenic purpura 313  
 Neonatal thrombocytopenic purpura 314  
 Wiskott-Aldrich syndrome 315  
 Henoch Schönlein purpura 315  
 Blood clotting defects 315  
 Haemophilia A 316  
 Haemophilia B (Christmas disease) 316
- Von Willebrand disease 316  
 Disseminated intravascular coagulation consumption coagulopathy 317  
 Acute leukaemias 318  
 Meningeal and testicular leukaemia 319
- 16. Paediatric Rheumatology 323**  
*Paul Galea, Krishna M Goel*
- Introduction 323  
 Causes of arthralgia and arthritis in children 323  
 Juvenile idiopathic arthritis 323  
 Treatment of juvenile idiopathic arthritis 327  
 Physiotherapy and occupational therapy 329  
 Juvenile reactive arthritis 329  
 Benign joint hypermobility syndrome 330  
 Limb pains of childhood with no organic disease (idiopathic limb pains) 330  
 Juvenile dermatomyositis 331  
 Paediatric systemic lupus erythematosus 333  
 Neonatal lupus erythematosus 334  
 Juvenile scleroderma 335  
 Juvenile systemic sclerosis 336  
 Vasculitic syndromes 336
- 17. The Urinary System 340**  
*Krishna M Goel*
- Introduction 340  
 Acute post-streptococcal glomerulonephritis 340  
 Primary IGA nephropathy 342  
 Nephrotic syndrome 342  
 Congenital nephrotic syndrome 343  
 Urinary tract infections 344  
 Renal tuberculosis 346  
 Hypertension in children 346  
 Renal vein thrombosis 350  
 Renal calculi (urolithiasis) 350  
 Hypophosphataemic vitamin D-resistant rickets (phosphaturic rickets) 351  
 Renal fanconi syndrome (cystinosis) 352  
 Nephrogenic diabetes insipidus 353  
 Renal tubular acidosis 354  
 Nocturnal enuresis 354  
 Haemolytic uraemic syndrome (D+HUS, D-HUS) 356  
 Acute renal failure 356  
 Chronic renal failure 358
- 18. Diseases of Nervous System 360**  
*Prabhakar D Moses, Maya Mary Thomas, Beena Koshy*
- Introduction 360
- **Congenital malformations of CNS 360**
    - Microcephaly 360
    - Craniosynostosis 361
  - **Infections of the nervous system 361**
    - Pyogenic meningitis 361
    - The Waterhouse-Friderichsen syndrome 363
    - Aseptic meningitis 363
    - Acute encephalitis and encephalopathy 364
    - Sclerosing panencephalitis 365



- Acute encephalopathy 365
- Tuberculosis of the central nervous system 366
- Brain abscess 367
- Neurocysticercosis 367
- **Acute flaccid paralysis 368**
  - Acute postinfectious polyneuropathy (Guillain-Barre's syndrome) 369
- **Convulsions in infancy and childhood 370**
  - Febrile seizures 375
- **Childhood stroke 375**
- **Movement disorders 378**
  - Rheumatic chorea (Sydenham's chorea, St. Vitus dance) 379
- **Neurocutaneous syndromes 379**
  - Neurofibromatosis (Von Recklinghausen's disease) 379
  - Tuberous sclerosis (epiloia) 380
  - Sturge-Weber syndrome (encephalofacial angiomatosis) 380
  - Ataxia-telangiectasia (Louis-bar syndrome) 381
  - Von Hippel-Lindau disease 381
- **Neurodegenerative disorders 381**
  - Neuronal ceroid lipofuscinoses 382
- **Neuromuscular disorders 382**
  - Spinal muscular atrophy (SMA) 382
  - Muscular dystrophy 383
  - Myasthenia gravis 384
  - Congenital myasthenic syndromes 385
- **Autonomic nervous system 385**
  - Familial dysautonomia (Riley-Day syndrome) 385
- **Brain tumour in children 386**
- **Cerebral palsy 386**
- **Learning disorders 392**
  - Learning disability (developmental retardation) 392
  - Management of children with learning impairment 398
- 19. Accidental Poisoning in Childhood 399**
  - Krishna M Goel*
  - Introduction 399
  - Assessment of the child and management 399
  - Poison identification and assessment of the severity of overdose 401
  - Salicylate poisoning 403
  - Paracetamol poisoning 403
  - **Ibuprofen 404**
    - Acute iron poisoning 404
    - Barbiturate poisoning 405
    - Poisoning by antihistamines 405
    - Poisoning by tricyclic and related antidepressants 405
    - Atropine poisoning 405
  - **Antimalarials 406**
    - Poisoning by digoxin 406
    - Poisoning by petroleum distillates, insecticides and weed-killers 406
    - Acute alcohol poisoning 407
    - Lead poisoning 407
    - Caustic ingestion 408
    - Swallowed foreign bodies 409
  - Acute carbon monoxide poisoning 410
  - Snake bite 410
  - Insect stings 411
  - Marine stings 411
  - Plant and mushroom poisoning 411
  - Drowning and near drowning 411
- 20. Metabolic Diseases 413**
  - Peter Galloway, Rajeev Srivastava, Krishna M Goel*
  - Inborn errors of metabolism 413
  - Common aetiological principles 413
  - Treatable disorders 414
  - Clinical approach to diagnosis 415
  - **Specific common disorders 416**
    - Disorders of amino acid metabolism 416
    - Other disturbances of amino acid metabolism 419
    - Disorder of branched-chain amino acid metabolism 420
  - **Urea cycle disorders 420**
    - Disorders of the sulphur-containing amino acids 421
  - **Disorders of specific sugars 421**
    - Pathogenesis 421
    - Clinical features 422
    - Diagnosis 422
    - Treatment 422
    - Disorders of purine and pyrimidine metabolism 423
  - **Congenital methaemoglobinaemia 424**
    - Aetiology 424
    - Pathogenesis 424
    - Clinical features 424
    - Diagnosis 424
    - Treatment 424
    - Glycogen storage disorders 424
    - Inborn errors of lipid metabolism (the lipidoses) 427
    - The mucopolysaccharidoses 429
    - Mitochondrial defects 431
    - Peroxisomal disorders 432
- 21. Endocrine Disorders 434**
  - Louis Low*
  - Hypopituitarism 434
  - Disorders of the posterior pituitary 435
  - Short stature 436
  - Tall stature 438
  - Obesity 438
  - Thyroid gland 439
  - Parathyroid glands 445
  - Rickets 447
  - The gonads 448
  - Adrenal gland 450
  - Disorders of sex development 455
  - Diabetes mellitus 456
  - Hypoglycaemia 460
- 22. Paediatric Orthopaedics 462**
  - Benjamin Joseph*
  - Introduction 462
  - Deformities 462

- Gait abnormalities 462
- Musculoskeletal pain 465
- Paralysis and pseudoparalysis 465
- Joint stiffness 466
- Congenital anomalies 466
- **Developmental problems 472**
  - Flatfoot 472
  - Paralytic conditions 475
  - Infections of bone and joints 478
  - Inherited disorders of bone 479
  - Tumours of bone 481
  - Hip pain in children and adolescence 482
- 23. Paediatric Dentistry 484**

*Richard Welbury, Alison M Cairns*

  - Dental anatomy 484
  - Caries 486
  - Oral pathology/oral medicine 487
  - Infection 495
  - Bacterial infection 496
  - Anomalies 498
  - Dentoalveolar trauma 502
  - Oral manifestations of systemic disease 507
- 24. Immunity and Allergy 508**

*Rosemary Anne Hague*

  - Components of the immune system 508
  - The next line of defence: innate (non-specific) immunity 509
  - Cells of innate immune system 510
  - The adaptive (acquired) immune system 510
  - Why are neonates and infants prone to infection? 512
  - Nutrition and immunity 513
  - Problems with the immune system 513
  - Tests of cell mediated immunity 515
  - Test for humoral immunity 515
  - Primary immunodeficiency disorders 515
  - **Allergy 517**
    - The immunology of allergic diseases 518
    - Mediators of the allergic response 519
    - Epidemiology 519
    - Food allergy 520
    - Diagnosis of allergy 522
    - Management of allergy 524
    - Prophylactic medications 524
    - Future developments 526
- 25. Immunisation Against Infectious Diseases 527**

*Jugesh Chhatwal*

  - Immunisation 527
  - Adverse events 528
  - Travel immunisation 532
- 26. Infectious Diseases 533**

*Jugesh Chhatwal*

  - Diphtheria 533
  - Pertussis (Whooping cough) 535
  - Tetanus 536
  - Enteric fever (typhoid fever) 538
  - Shigellosis 541
  - Streptococcal infections 541
  - Pneumococcal infections 543
  - Meningococcal disease 543
  - Haemophilus influenzae* 544
  - Staphylococcal infections 545
  - Tuberculosis 546
  - Directly observed treatment short course (DOTS) 549
  - Leprosy 549
  - Syphilis 551
  - Leptospirosis 552
  - Measles 552
  - Mumps 555
  - Rubella 556
  - Varicella virus (chickenpox) 556
  - Poliomyelitis 558
  - Rabies 558
  - Japanese encephalitis 558
  - Dengue fevers 559
  - Human immunodeficiency virus infection (AIDS) 561
  - Associated infections 562
  - Perinatal transmission 562
  - Malaria 563
  - Toxoplasmosis 565
  - Amoebiasis 566
  - Giardiasis 567
  - Kala azar (visceral leishmaniasis) 567
- 27. Paediatric Ophthalmology 569**

*Sarada David, Kirsteen J Thompson*

  - Visual assessment in children 569
  - Nystagmus 573
  - Intrauterine infectious diseases 574
  - Orbital cellulitis 578
  - Allergic conjunctivitis 578
  - Lacrimal system 579
  - Cornea 580
  - Systemic diseases with corneal manifestations in childhood 584
  - Childhood lens disorders 585
  - Paediatric glaucoma 587
  - Uveitis in children 588
  - Retinoblastoma 591
  - Retinopathy of prematurity 593
  - Traumatic retinopathy 594
  - Preventive ophthalmology 594
  - The child with visual impairment 595
- 28. Haematological Investigations in Children 596**

*Christina Halsey, Elizabeth A Chalmers*

  - Full blood count 596
  - Red cell indices 596
  - Blood film 596
  - Reticulocyte count 597
  - Normal ranges 597
  - Investigation of low haemoglobin in infancy and childhood 598
  - Hypochromic microcytic anaemia 598
  - Tests to diagnose iron deficiency 601

- Tests to diagnose thalassaemia 601  
 Macrocytic anaemia 602  
 Normocytic anaemia 602  
 Investigation of anaemia in neonates 604  
 Polycythaemia 604  
 White cell disorders 604  
 Bone marrow examination 606  
 Platelet disorders 607  
 Coagulation testing in infants and children 607  
 When to perform a coagulation screen 608  
 Coagulation tests 608  
 Monitoring of anticoagulant therapy 610
- 29. Biochemical and Microbiological Investigations in Paediatrics 611**  
*Peter Galloway, Craig Williams*
- Introduction 611  
 What are the roles of diagnostic tests? 611  
 What factors are important in interpreting data? 612  
 What is normal? 612  
 What do you need to know about biochemical tests? 613  
 What do you need to know about microbiology tests? 614
- 30. Paediatric Emergencies 618**  
*Alastair Turner, NV Doraiswamy*
- Introduction 618  
 Differences between adults and children in the emergency department 618  
 Basic structured approach to management 619  
 Cardiac arrest 620  
 Paediatric emergencies 628
- 31. Disorders of Emotion and Behaviour 639**  
*Michael Morton, David James*
- An introduction to child and adolescent psychiatry 639  
 Problems in early childhood 641  
 Working with physically ill children 642  
 Emotional disorders and medically unexplained symptoms 643  
 Elimination disorders 646  
 Behaviour disorders 647  
 Eating disorders 649  
 Psychotic disorders 650  
 Communication disorders 650  
 Disorders with motor presentations 651  
 Problems of learning 652  
 Working with social services and police 653
- 32. Paediatric Radiology 655**  
*Sanjay V Maroo, Sandra J Butler*
- General considerations in paediatric radiology 655  
 Radiation effects on children 655  
 Imaging modalities used in paediatric imaging 655  
 Respiratory and cardiac 657  
 Medical causes 660  
 Surgical causes 663  
 A child with a mediastinal mass 665  
 Chest wall masses 668  
 Congenital heart disease 669  
 Cyanotic child with congenital heart disease 672  
 Other cardiac and related conditions 673
- **Abdomen 675**  
 A neonate with bilious vomiting 675  
 Other abdominal conditions in children 678  
 The child with an abdominal mass 682
  - **Paediatric neuroradiology 685**  
 Congenital brain malformations 685  
 Holoprosencephaly 686  
 Trauma, hypoxia/ischæmia and haemorrhage 689  
 Infections, tumours and hydrocephalus 694  
 Congenital spine lesions 700
  - **Paediatric skeletal radiology 702**  
 Skeletal dysplasias 702  
 Mucopolysaccharidoses 704  
 Paediatric hip abnormalities 707  
 Metabolic bone disorders 710  
 Inflammatory joint and muscle conditions 711  
 Bone infections 712  
 Haemolytic anaemias 713  
 Langerhans' cell histiocytosis 714  
 Paediatric bone tumours 716  
 Osteosarcoma 716
  - **Paediatric renal imaging 717**  
 Congenital anomalies 717  
 Renal ectopia 719  
 Urinary tract stones and nephrocalcinosis 722  
 Dilatation of urinary tract 722  
 Neoplastic diseases 724
- 33. Paediatric Maxillofacial Surgery 727**  
*Khursheed F Moos*
- Introduction 727  
 Congenital deformity 728  
 Craniofacial microsomia 732  
 Clinical features 733  
 Treacher collins syndrome 736  
 Infection 738  
 Trauma 740  
 Pathology of the jaws and adjacent structures 748  
 Vascular anomalies 751
- 34. A Prescription for Play 753**  
*Phyllis Kilbourn, Rosemary Sabatino*
- Introduction 753  
 Defining play 753  
 Importance of play 753  
 Description of forms of play 753  
 Play: an essential element in child development 755  
 The dangers of play deprivation 757  
 Advice for parents (or caregivers) 757  
 Play's role in emotional health 758  
 Emotional issues stemming from trauma 758

Defining organised play activities (play therapy)	758		
Play: a medium of communication	759		
Methods of play therapy	759		
Benefits of organised play	759		
<b>35. Paediatric Rehabilitation</b>		<b>763</b>	
<i>Judy Ann John, Lydia Edward Raj</i>			
Introduction	763		
The rehabilitation programme	764		
<b>36. Prescribing for Children</b>		<b>780</b>	
<i>James Wallace</i>			
The challenge	780		
Pharmacokinetics	780		
Compliance and concordance	781		
The issues in practice	782		
Prescribing in paediatrics	783		
Other issues	785		
<b>37. Child Abuse and Neglect—How do We Protect these Children?</b>		<b>786</b>	
<i>Jean Herbison</i>			
Introduction	786		
Various forms of abuse	786		
Emotional abuse and neglect	792		
Physical abuse	793		
Child sexual abuse	798		
Fabricated and induced illness	799		
Child trafficking	799		
Child protection standardised procedures	801		
Legal system	801		
Section 1	803		
Section 2	803		
Section 3	803		
Child protection process for all staff	804		
Standard operating procedure in relation to child protection concerns	814		
<b>38. Practical Paediatric Procedures</b>			<b>821</b>
<i>Alastair Turner, Robert Carachi, Krishna M Goel</i>			
Introduction	821		
Preparation for practical procedures	821		
Restraint	821		
Sedation and analgesia for clinical procedures	822		
Routine practical procedures	824		
Other practical procedures	838		
<b>Appendices</b>			<b>855</b>
Appendix A: Guide to biochemical values	855		
Appendix B: A guide to normal ranges for the FBC in infancy and childhood	857		
Appendix C: Surface area nomograms in infants and children	858		
Appendix D: Percentiles of age specific blood pressure measurements in boys and girls	859		
Appendix E: Childhood myositis assessment scale (CMAS) scoring sheet	863		
<b>Index</b>			<b>865</b>

# Paediatric History and Examination

## THE HISTORY

### Semeiology

The study of symptoms.

### Disease

“A condition in which, as a result of anatomical change or physiological disturbance, there is a departure from the normal state of health.” There is a lot of variation in normal people.

## CLINICAL MANIFESTATIONS OF DISEASE

### Symptoms

Something the patient feels or observes which is abnormal, e.g. pain, vomiting, loss of function. A good history provides a clue to the diagnosis in 80% of patients.

### Signs

Physical or functional abnormalities elicited by examination, e.g. tenderness on palpation, a swelling, a change in a reflex picked up on physical examination. Always inspect, palpate, percuss then auscultate.

### The Patient

Why do patients go to the doctor?

- They are alarmed. They believe themselves to be ill and are afraid
- Relief of symptoms
- Cure
- Prognosis.

### The Doctor

- Helps to diagnose the disease
- Symptoms + signs → differential diagnosis → Δ definitive diagnosis
- Acquired knowledge allows recognition + interpretation + reflection → therapy + prognosis.

## How is Knowledge Acquired?

- Reading: 10–20% retention
- Taught by others: 10% retention, e.g. lectures, tutorials, computer programs
- Personal experience: 80% retention, e.g. bedside teaching.

## A Description of the Disease

- Knowledge of the causation (aetiology)
- Pathological, anatomical and functional changes which are present (morphology)
- Assembly of all the relevant facts concerning the past and present history (symptoms)
- Full clinical examination and findings (signs)
- Simple laboratory tests, such as an examination of the urine or blood and X-rays (investigations).

## Prognosis

Depends on:

- Nature of the disease
- Severity
- Stage of the disease.

Statistical statements about prognosis can often be made, e.g. the average expectation of life in chronic diseases or the percentage mortality in the acute cases. These must be applied with great caution to individual patients. Patients expect this more and more with internet access. Often information has to be interpreted. They may be testing your knowledge and comparing it to other doctors or information obtained.

## Syndrome

A group of symptoms and/or signs which is commonly occur together, e.g. Down's syndrome and Beckwith-Wiedemann syndrome (\*).

\* Oxford dysmorphology database

**Warning!**

When discussing medical matters in a patient's hearing, certain words with disturbing associations should be avoided. This is so, even if they are not relevant to the particular individual.

**HISTORY AND DOCUMENTATION****History of Present Condition***General Description*

The taking of an accurate history is the most difficult and the most important part of a consultation. It becomes progressively simpler as the physician's knowledge of disease and experience increases, but it is never easy. As far as possible the patients' complaint list should be written (in order of relevance), unaltered by leading questions, but phrased in medical terms. When the patient's own phraseology is used, the words should be written in inverted commas, e.g. "giddiness", "wind", "palpitation" and an attempt should be made to find out precisely what they mean to the patient.

*Onset:* The order of onset of symptoms is important. If there is doubt about the date of onset of the disease, the patient should be asked when he last felt quite well and why he first consulted his doctor.

*Therapy:* Notes on any treatment already received and of its effect, if any, must be made as it might alter disease states, e.g. appendicitis masked by drug treatment for a urinary tract infection (UTI).

*Symptomatic Enquiry*

After the patient has given a general description of his illness, the system mainly involved will usually, but by no means always, be obvious. The patient should then be questioned about the main symptoms produced by diseases of this system. This should be followed by enquiries directed towards other systems. Remember different systems may produce similar symptoms.

This systematic enquiry runs from the "head to the toes" (32 questions). However, relevant questions are grouped together under systems. Here are some examples.

**Alimentary Tract Questions**

*Abdominal pain or discomfort (24):* Site, character, e.g. constant or colicky, radiation, relationships to food and bowel actions. Shift in site.

*Nausea and vomiting (15):* Frequency and relationship to food, etc. (positive vomiting), amount of vomitus, contents, colour, blood (haematemesis), etc.

*Flatulence (16, 26):* Eructation (belching) and passage of flatus.

*Bowels (25):* Constipation (recent or long standing and severity); diarrhoea (frequency and looseness of motions); presence of blood and mucus in faeces; altered colour of faeces—black from altered blood (melaena); clay coloured in obstructive jaundice; bulky and fatty in steatorrhoea, piles. Tenesmus painful sensation and urgent need to defecate (Rectal pathology).

*Appetite and loss of weight (17):* Recent looseness of clothing. Types of food in diet and amounts eaten.

*Difficulty in swallowing (18a):* Food hard or soft, fluids, level at which food "sticks". Pain, regurgitation. Progression from solid food to liquid.

*Heartburn, acid eructations "and belching".*

*Jaundice (17):* Constant or fluctuating.

*Note: Steatorrhoea:* Bulky pale foul smelling and greasy stools due to:

- Depressed fat digestion (pancreatic lipase and bile)
- Depressed fat absorption (small intestine mostly jejunum).

**Cardiovascular System Questions**

*Breathlessness (11):* Dyspnoea on exertion [DOE (degree)], dyspnoea at rest (DAR), time especially if wakes at night, position, relieving factors, gradual or sudden onset, change, duration [paroxysmal nocturnal dyspnoea (PND)], precipitating factors, number of pillows used.

*Pain in chest (19):* Site on exertion or at rest, character, radiation, duration, relief by drugs, etc. accompanying sensations, e.g. breathlessness, vomiting, cold sweat, pallor, frequency, other relieving factors.

*Swelling of ankles (23):* Time of day.

*Swelling of abdomen (27):* Tightness of trousers or skirt and bloatedness.

*Palpitation (20):* Patient conscious of irregularity or forcefulness of heart beat.

*Dizziness and faints:* Hypertension pain.

*Pain in the legs on exertion (22):* Intermittent claudication at rest, or exertion and other vascular problems.

*Coldness of feet (23):* Raynaud's phenomenon.

*Dead fingers or toes (22):* Pain, sensation, ulceration and diabetes.

## Respiratory System Questions

*Cough (12):* Character, frequency, duration, causing pain and timing. Productive.

*Sputum (13):* Quantity, colour (frothy, stringy and sticky odour), colour when most profuse (during the day and the year and the affect of posture (bronchiectasis) presence of blood haemoptysis. Is the blood red or brown? Is it pure blood or 'specks'? e.g. acute or chronic bronchitis.

*Breathlessness (11):* On exertion or at rest. Expiratory difficulty, precipitating factors, cough, fog, emotion, change of environment and wheezing.

*Pain in chest:* Location, character, affected by respiration, coughing, position ( $\uparrow\downarrow$ pain) and weight loss.

*Hoarseness (10):* With or without pain (involvement of recurrent laryngeal nerve) and other associated features, e.g. neurological.

*Throat (10):* Soreness, tonsillitis, ulcers, infection.

*Nasal discharge or obstruction (7):*

*Bleeding from nose (8):* Epistaxis.

*Sweating (14):* Day or night, associated symptoms and amounts.

*Wheezing (12):* Asthma, chest infection, relieving factor, chronic obstructive pulmonary disease (COPD)

*Smoking.*

## Central Nervous System Questions

*Loss of consciousness (1):* Sudden, warning, injuries, passage of urine, duration and after effects. Precipitating factor and witnesses?

*Mental state (3):* Memory, independent opinion of relative or friend sought. Orientation.

*Headache (2):* Character, site, duration, associated symptoms, e.g. vomiting, aura and timing.

*Weakness or paralysis of limbs or any muscles (21):* Sudden, gradual or progressive onset, duration and visual disturbance.

*Numbness or 'pins and needles' in limbs or elsewhere (22):* Paraesthesia, back pain, diabetes.

*Giddiness or staggering (5):* True vertigo, clumsiness, staggering and ataxia.

*Visual disturbance (4):* Seeing double (diplopia) dimness, zig zag figures (fortification spectra).

*Deafness or tinnitus (6):* Discharge from ears, pain and hearing loss.

*Speech disturbance (9):* Duration, onset, nature. Problems in reading or understanding.

## Genitourinary System Questions

*Micturition (29):* Frequency during day and night, retention, dribbling, and amount of urine passed. Pain on micturition (dysuria). Stress incontinence, urgency incontinence.

*Urine (30):* Colour and amount—smell, blood, colour, frothy.

*Lumbar pain (28):* Radiation, history of trauma and mechanical.

*Swelling of face or limbs (23):* Presence on rising, drugs, improve with movement and pain.

*Menstruation (31):* Age of onset (menarche) and age of cessation (menopause). Regularity, duration, amount of loss and pain (dysmenorrhoea). Inter-menstrual discharge—character, blood or otherwise. Vaginal discharge, quantity, colour (normally clear), smell and irritation. Any hormone replacement therapy (HRT) and child bearing age.

*Periods:* Time of menopause

- Post-menopausal bleeding
- Last normal menstrual period (LNMP)
- Menstrual cycle; number of days or interval, e.g. 4/28
- Regular or irregular
- Interval longest or shortest, e.g. 21–49
- Increase or decrease in flow.

## Locomotor System Questions

*Swelling:* One joint or multiple joints.

- Pain—back (22)
- When worse during day. Effects of exercise, lifting, etc.

*Stiffness:* Effect of exercise.

*Previous bone or joint injury:* Pain in joints. Where pain is worse in the morning or later during day or night. Whether it radiates from one joint to another.

## Skin Questions

*Occupation (32):* Exposure to irritants and drugs.

*Rashes:* Type, situation, duration, any treatment, painful and itching (psoriasis).

*Past history:*

- Diabetes
- Hypertension
- Rheumatic fever
- Heart disease
- Cystic fibrosis (CF)

- Spina bifida
- Other illnesses.

Illnesses, operations, injuries. Routine X-ray examinations. In female—obstetrical history: (1) number of deliveries and abortions, e.g. 3 + 1; (2) type of delivery, spontaneous vertex delivery (SVD), forceps, caesarean; (3) complication of puerperium or pregnancy.

### Family History

Married, number and health of children, health of partners, any illnesses in parents, grandparents, brothers, sisters, longevity or short lives, any illnesses similar to patients.

### Drug History

- Social and personal history
- Occupation.

## INTRODUCTION

At all times the doctor must show genuine concern and interest when speaking with parents. The parents and the child must feel that the doctor has the time, interest and competence to help them. A physician who greets the child by name irrespective of age will convey an attitude of concern and interest. Parents tell us about the child's signs and symptoms although children contribute more as they grow older.

The doctor-patient relationship gradually develops during history-taking and physical examination. Considerable tact and discretion are required when taking the history especially in the presence of the child: questioning on sensitive subjects should best be reserved for a time when the parents can be interviewed alone. It may therefore be necessary to separate the parent and the child-patient when taking the history especially when the problems are related to behaviour, school difficulties and socioeconomic disturbances in the home environment.

The medical student having been instructed in the history-taking and physical examination of adults needs to appreciate the modifications necessary when dealing with the child-patient. A basic template for history-taking is useful and serves as a reminder of the ground to be covered (Table 1.1). Initially the medical student may be confused because of the need to obtain information from someone other than the patient, usually the mother. Useful information may be obtained by observing the infant and young child during the history-taking. The older child should be given an opportunity to talk, to present their symptoms and to tell how they interfere with school and play activities.

The simple act of offering a toy, picture book or pen-torch is often an effective step toward establishing rapport. Rigid adherence to routine is both unnecessary and counter-productive. A lot may be learned of the family constellation

**Table 1.1:** History-taking—The paediatric patient

- Presenting problem
- History of the presenting problem
- Previous history
- Pregnancy and delivery
- Neonatal period and infancy
- Subsequent development
- Other disorders or diseases
- Dietary
- Immunisation
- Family history
- Parents
- Siblings
- Others
- Draw a family tree if indicated

and the parent-child relationship by simply observing the parent(s) and child during the history-taking and physical examination. Therefore watching, listening and talking are of paramount importance in paediatric practice and are invaluable in arriving at a working diagnosis.

### Key Learning Point

- ➔ Useful information may be obtained by observing the infant and young child during the history-taking.

## HISTORY OF PRESENT COMPLAINT

Even before language develops in the infant (Latin—without speech) parents can detect altered behaviour and observe abnormal physical signs. It is sensible to commence with the history of the presenting observations because that is what the parents have come to talk about. In the newborn infant the history from the attending nurse and medical staff is important.

Every endeavour should be made to ask appropriate questions and discuss relevant points in the history in order to identify the nature of the child's problems and come to a tentative diagnosis. Ask what the child is called at home and address the child with this name since otherwise he/she may be less forthcoming. Let the parents give the history in their own way and then ask specific questions. Ask, how severe are the symptoms; have the symptoms changed during the past days, weeks or months; has there been any change recently in the child's appetite, energy or activities; has the child been absent from school; has anyone who cares for the child been ill; has the child been thriving or losing weight; what change in behaviour has there been; has there been a change in appetite, in micturition or bowel



habits. An articulate older child can describe feelings and symptoms more accurately, as the child's memory for the time and sequence of events may be more precise, than the parents.

#### Key Learning Point

##### Establishing rapport

► The paediatrician should start the interview by welcoming and establishing rapport with the parent(s) and the child. Always refer to the infant or child by name rather than by "him", "her" or "the baby". Also ask children about their clothes, siblings' name, friends' name, their toys, what book, games or TV programs they enjoy. Thus spending sometime at the start of the interview would put both the child and the parents at ease.

## PAST MEDICAL HISTORY

The past history is the documentation of significant events which have happened in the child's life, and which may be of relevance in coming to a diagnosis. Therefore the doctor should try to obtain relevant information concerning the past from the family and any other sources that are available. It is useful, if the events are recorded in the sequence of their occurrence. A careful history should contain details of pregnancy, delivery, neonatal period, early feeding, the child's achievement of developmental milestones and details of admissions to hospital, with date, place and reason for admission. A complete list of current medication including vitamins and other supplements should be obtained. An enquiry should be made of any drug or other sensitivity which should always be prominently recorded. Details of immunisation and all previous infectious diseases should be elicited.

#### Key Learning Point

► Dietary history is of vital importance in paediatric history-taking especially if the child is neither thriving nor has vomiting, diarrhoea, constipation or anaemia.

## MOTHER'S PREGNANCY, LABOUR, DELIVERY AND THE NEONATAL PERIOD

The younger the child, the more important is the information about the period of intrauterine life. The history of pregnancy includes obstetric complications during the pregnancy; history of illness, infection or injury and social habits, e.g. smoking of the mother are important. Drug or alcohol ingestion and poor diet during pregnancy may have an adverse effect on the foetus and lead to problems. The estimated length of gestation and the birth weight of the baby

should be recorded. Details of any intrapartum or perinatal problems should be recorded.

## DIETARY HISTORY

The duration of breastfeeding should be recorded or the type of artificial feed and any weaning problems. The dietary history can be of major importance in paediatric history-taking. If the patient is neither thriving nor has vomiting, diarrhoea, constipation or anaemia then the physician must obtain a detailed dietary history. The dietary history should not only include solid foods, but also the consumption of liquid foods and any other supplements, such as vitamins. In this way the quality of the diet and the quantity of nutrients can be assessed and compared to the recommended intake. Any discrepancy between the actual and recommended intake may have a possible bearing on the diagnosis.

## DEVELOPMENTAL HISTORY

Inquiries about the age at which major developmental milestones in infancy and early childhood were achieved are necessary when faced with an infant or child who is suspected of developmental delay. On the other hand the child who is doing well at school and whose physical and social activities are normal, less emphasis on the minutiae of development is needed. Some parents are vague about the time of developmental achievements unless, very recently acquired, but many have clear recall of the important events such as smiling, sitting and walking independently. It can be helpful to enquire whether this child's development paralleled that of other children.

## FAMILY AND SOCIAL HISTORY

The health and educational progress of a child is directly related to the home and the environment. Medical, financial and social stresses within the family sometimes have a direct or indirect bearing on the child's presenting problem. It is, therefore, essential to know about the housing conditions and some information of parental income and working hours, as well as the child's performance in school and adjustment to playmates.

The family history should be thoroughly evaluated. The age and health of the close relatives are important to record. Height and weight of parents and siblings may be of help especially when dealing with children of short stature, obesity, failure to thrive, or the infant with an enlarged head. Consanguinity is common in some cultures and offspring of consanguineous marriages have an increased chance of receiving the same recessive gene from each parent and thus developing a genetically determined disease. Therefore, it is important to draw a family tree and to identify children at high-risk of genetic disease, and to make appropriate referrals.

**Key Learning Point**

➤ A history of recent travel abroad, particularly in tropical areas, is important as the child may have a disorder uncommon in his/her own country, but having been contracted in another country where disease may be endemic.

**PHYSICAL EXAMINATION**

The physical examination of the paediatric patient requires a careful and gentle approach. It should be carried out in an appropriate environment with a selection of books or toys around, which can be used to allay the apprehension and anxiety of the child. More can be learned by careful inspection than by any other single examination method. The baby should be examined in a warm environment in good light. Nappies must be removed to examine the baby fully. The doctor must look first at the baby as a whole noting especially the colour, posture and movements. Proceed to a more detailed examination starting at the head and working down to the feet "Top to Toe".

It is important to realise that the child may be apprehensive with a stranger, especially when faced with the unfamiliar surroundings of a surgery or hospital outpatient department. It is essential that the doctor be truthful with the child regarding what is going to be done. The child should never be made to face sudden unexpected manoeuvres and should be allowed to play with objects such as the stethoscope. It may be useful to let him or her examine a toy animal or doll to facilitate gaining confidence. Infants and young children are often best examined on the mother's lap where they feel more secure. The doctor should ensure that his hands and instruments used to examine the child are suitably warmed. It is not always mandatory to remove all the child's clothes, although it is often essential in the examination of the acutely ill child. Procedures, which may produce discomfort, such as examination of the throat, ears or rectal examination should be left until towards the end of the examination. The order of the examination may be varied to suit the particular child's needs. Awareness of the normal variations at different ages is important.

A thorough physical examination is a powerful therapeutic tool especially if the problem is one primarily of inappropriate parental anxiety. Understandably parents do not usually accept reassurance, if the doctor has not examined the child properly. Examination of the infant or child is often preceded by recording the patient's height, weight and head circumference on the growth chart. This may have been done by a nurse before the doctor sees the family. These measurements are plotted on graphs or charts, which indicate the percentiles or standard deviations at the various ages throughout childhood. If these measurements

are outwith the 3rd to 97th centile for children of that sex and age further study is indicated. If previous records of height, weight or head circumference are available for comparison with the current measurements this may provide considerable help towards diagnosis and management. Inquiry of parental height, weight or head size may also be important, e.g. familial macrocephaly or constitutional short stature.

**Key Learning Point**

➤ Allow the child-patient to see and touch the stethoscope, auriscope, ophthalmoscope and other tools, which are going to be used during examination. Ask the child, which ear or which part of the body the child would like to be examined first. It is vital to use the reassuring voice throughout the examination of the child.

**General Inspection**

The general appearance of the child may suggest a particular syndrome. Does the child look like the rest of the family? The facies may be characteristic in Down's syndrome and other chromosomal disorders or in mucopolysaccharidoses. Peculiar odours from an infant may provide a clue to diagnosis of aminoacidurias, such as maple syrup disease (maple syrup like odour), phenylketonuria (mousy odour), or trimethylaminuria (fishy odour). A more detailed examination should then be performed. The most valuable of the doctor's senses are his eyes as more can be learned by careful inspection and also on watching the patient's reactions than any other single procedure.

**Colour**

Should be pink with the exception of the periphery, which may be slightly blue. Congenital heart disease is only suggested if the baby has central cyanosis. A pale baby may be anaemic or ill and requires careful investigation to find the cause. A blue baby may have either a cardiac anomaly or respiratory problems and rarely methaemoglobinaemia.

**Key Learning Point****Central cyanosis**

➤ Central cyanosis in a child of any age should always raise the possibility of congenital heart disease. Ideally, the best areas to look for central cyanosis are the tongue and buccal mucosa, not the limbs and the nails.

**Posture and Movements**

A term baby lies supine for the first day or two and has vigorous, often asymmetric movements of all limbs. In contrast a sick baby adopts the frog position with legs

abducted, externally rotated and is inactive. Older infants and children should be observed for abnormal movements, posture and gait.

**Key Learning Points**

- Always leave the most upsetting parts of the examination until the end, such as inspection of the throat or taking the blood pressure.
- If epiglottitis is a possibility do not examine the throat because obstruction may be precipitated

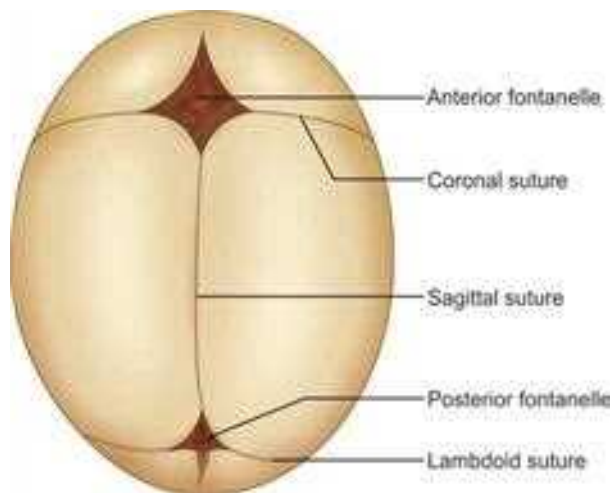
**Skin**

The skin is a major body organ which, because of the larger surface area in relationship to weight, of the young means that the skin is relatively more important in the immature. It forms a barrier against environmental attack and its structure and function reflects the general health of the child, i.e. in states of malnutrition and dehydration. The presence of any skin rash, its colour and whether there are present macules, papules, vesicles, bullae, petechiae or pustules should be recorded (Table 1.2). The skin texture, elasticity, tone and subcutaneous thickness should be assessed by picking up the skin between the fingers. Pigmented naevi, strawberry naevi, haemangiomata or lymphangiomata may be present and may vary in size and number. They may be absent or small at birth and grow in subsequent days or weeks.

**Key Learning Point**

**Port-wine stain**

- Unilateral port-wine stain over the distribution of the ophthalmic division of the trigeminal nerve is usually a manifestation of Sturge-Weber syndrome. It may be associated with seizures, glaucoma, hemiparesis and mental retardation.



**Fig. 1.1:** Top of head anterior fontanelle and cranial sutures

**Head**

The head should be inspected for size, shape and symmetry. Measurement of the head circumference [occipitofrontal circumference (OFC)] with a non-elastic tape by placing it to encircle the head just above the eyebrows around maximum protuberance of the occipital bone should be performed and charted. In the infant the skull should be palpated to determine the size and tension in the fontanelles and assess the skull sutures (Fig. 1.1). Premature fusion of sutures suggests craniostenosis. In the neonate the posterior fontanelle may be very small and subsequently closes by 3 months of age, but the anterior fontanelle is larger, only closing at around 18 months. A tense and bulging fontanelle suggests raised intracranial pressure and a deeply sunken one suggests dehydration.

Large fontanelles, separation of sutures, delayed closure of the fontanelles may be associated with raised intracranial

**Table 1.2:** Dermatological terminology

Terminology	Definition
Macule	Area of discoloration, any size, not raised-flat with skin
Papule	Small raised lesion (< 5 mm)
Petechiae	Haemorrhage in skin, non-blanching (< 1 mm)
Purpura	Haemorrhage in skin, non-blanching (2–10 mm in diameter)
Ecchymoses	Large bruise, non-blanching
Vesicle	Small blister, elevated, fluid-filled (< 5 mm)
Bullae	Large blister, elevated, fluid-filled (> 5 mm)
Weal	Elevation in skin, due to acute oedema in dermis, surrounding erythematous macule
Pustule	Elevated, pus-filled
Lichenification	Thickened skin, normal lines in skin more apparent



**Fig. 1.2:** Method of restraining a child for examination of the ear

pressure or other systemic disorders, such as hypothyroidism and rickets.

#### Key Learning Point

##### Occipitofrontal circumference

➔ An abnormally “large head” (more than 97th centile or 2 SD above the mean) is due to macrocephaly, which may be due to hydrocephalus, subdural haematoma or inherited syndromes. Familial macrocephaly (autosomal dominant) is a benign familial condition with normal brain growth.

#### Ears

Position and configuration of the ears should be observed. Whilst abnormalities, such as low setting of the ears is frequently associated with renal tract anomalies absence of an ear or non-development of the auricle will require early referral to an otolaryngologist. It often requires the parent to hold the child on his or her lap and provide reassurance during the examination. Methods of doing this are illustrated in Figure 1.2. Parents are usually very competent in detecting hearing impairment. The exception to this is where the child is mentally retarded. All infants should be given a screening test for hearing at 6 months of age. Simple testing materials are required, e.g. a cup and spoon, high and low pitched rattles, and devices to imitate bird or animal sounds, or even snapping of finger tips are usually effective if hearing is normal. The sounds should be made quietly at a distance of 2–3 feet out of view of the child. By 6 months of age a child should be able to localise sound. To pass the screening test the child should turn and look directly at the source of the sound.

#### Key Learning Point

##### Hearing deficit

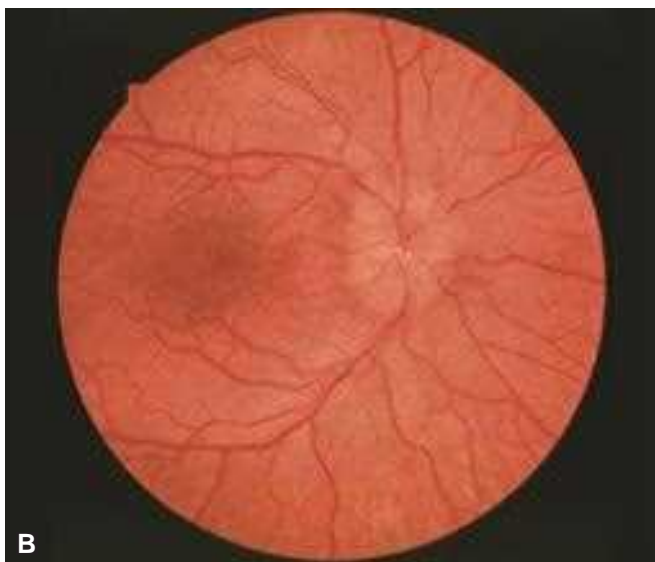
➔ A number of children with hearing deficits may not be diagnosed until they are 2 years of age. The main pointers to hearing deficits include parental concern about their child's hearing, speech delay, and lack of developmental markers of hearing.

#### Eyes

These should be inspected for subconjunctival haemorrhages which are usually of little importance, for cataracts, for papilloedema and congenital abnormalities, such as colobomata (Figs 1.3A and B). ‘Rocking’ the baby from the supine to vertical position often results in the eyes opening so they can be inspected. Squint is a condition in which early diagnosis and treatment is important. There are two simple tests which can be carried out to determine whether or not a squint is present.

1. The position of the “corneal light reflection” should normally be in the centre of each pupil if the eyes are both aligned on a bright source of light, usually a pen torch. Should one eye be squinting then the reflection of the light from the cornea will not be centred in the pupil of that eye. It will be displaced outwards, if the eye is convergent and inwards towards the nose, if the eye is divergent. It may be displaced by such a large amount that it is seen over the iris or even over the sclera, where of course it may be rather more difficult to identify, but with such obvious squints the diagnosis is usually not in doubt.
2. In the “cover test” one chooses an object of interest for the child, e.g. a brightly coloured toy with moving components. When the child is looking at the object of interest the eye thought to be straight is covered with an opaque card and the uncovered eye is observed to see whether it moves to take up fixation on the object of interest. If the child has a convergent squint then the eye will move laterally to take up fixation, and this is the usual situation, since convergent squints are four times more common than divergent squints. If the eye were divergent it would move medially.

The most common cause for apparent blindness in young children is developmental delay. Assessment of whether a young baby can see is notoriously difficult, fixation should develop in the first week of life, but an early negative response is of no value as the absence of convincing evidence of fixation is not synonymous with blindness. The failure to develop a fixation reflex results in ocular nystagmus, but these roving eye movements do not appear until the age of 3 months.



**Figs 1.3A and B:** (A) Congenital cataract and (B) Papilloedema

A misleading response may be obtained when a bright light stimulus is applied to a child preferably in a dimly lit room. The normal response is a blinking or “screwing up” the eyes and occasionally by withdrawing the head. This is a subcortical reflex response and may be present in babies despite them having cortical blindness. The absence of this response increases the probability of blindness.

#### Key Learning Point

##### Distraction and play

- ➔ If the doctor cannot distract the infant or make the awake “infant” attend to an object, look at the paediatrician’s face, or a sound, consider a possible visual or hearing deficit.



**Fig. 1.4:** Gingival hyperplasia caused by phenytoin

#### Face

Abnormalities of facial development are usually obvious and an example is the infant with cleft lip. Associated with this there may be a cleft palate, but full visual examination of the palate including the uvula is necessary to ensure that the palate is intact and there is not a submucous cleft of the soft palate or a posterior cleft. Submucous and soft palate clefts cannot be felt on palpation.

#### Mouth

Inspection of the mouth should include visualisation of the palate, fauces, gum disease and the dentition (Fig. 1.4). A cleft lip is obvious, but the palate must be visualised to exclude a cleft. The mouth is best opened by pressing down in the middle of the lower jaw. A baby is rarely born with teeth, but if present these are almost always the lower central incisors. The soft palate should be inspected to exclude the possibility of a submucous cleft which could be suggested by a bifid uvula. Small fibromata are sometimes seen in the gums. They are white and seldom require treatment. These are normal. The lower jaw should be seen in profile as a receding chin (micrognathia) may be the cause of tongue swallowing or glossoptosis (Pierre Robin syndrome) and it may be associated with a cleft palate.

#### Neck

Examination of the neck may reveal congenital goitre and midline cysts which may be thyroglossal or dermoid in origin. Lateral cysts, which may be of branchial origin or sometimes there may be extensive swellings, which may be cystic hygroma or lymphangiomas. In early infancy a sternomastoid tumour may be palpable in the mid region of the sternomastoid muscle. Associated with this there may be significant limitation of rotation and lateral flexion of the neck. Palpation along the clavicle will define any tenderness or swelling suggestive of recent or older fractures.



**Fig. 1.5:** Pectus excavatum (funnel-chest)

### Chest

The shape, chest wall movement and the nature and rate of the breathing (30–40 per minute) as well as the presence of any indrawing of the sternum and rib cage should be noted. In a normal baby without respiratory or abdominal problems the abdomen moves freely during breathing and there is very little chest movement. Most of the movements of the breathing cycle are carried out by the movement of the diaphragm. The nipples and axillary folds should be assessed to exclude conditions, such as absent pectoral muscles. In Poland syndrome there is amastia, associated with ipsilateral absence of sternal head of pectoralis major. Ten per cent may have dextrocardia, dextroversion, or syndactyly. Anterior chest wall deformities, such as pectus excavatum (funnel chest) and pectus carinatum (Pigeon chest) should be recorded (Fig. 1.5).

### Cardiovascular

Examination of the cardiovascular system of infants and children is carried out in a similar manner to that of adults. The examiner should always feel for femoral pulses and ascertain whether there is any radiofemoral or brachiofemoral delay as this would suggest the possibility of coarctation of the aorta. The most important factor in recording the blood pressure of children is to use a cuff of the correct size. The cuff should cover at least two-thirds of the upper arm. If the cuff size is less than this a falsely high blood pressure reading may be obtained. In small infants relatively accurate systolic and diastolic pressures as well as mean arterial pressure can be obtained by use of the Doppler method. The apex should be visible and palpable and the position noted. The precordial areas should be palpated for the presence of thrills. If the apex beat is not obvious look for it on the right side of the chest as there could be dextrocardia or a left-sided congenital diaphragmatic hernia with the heart pushed to the right or

collapse of the right lung. All areas should be auscultated while the baby is quiet systolic murmurs may be very harsh and can be confused with breath sounds.

### Lungs

Small children frequently cry when the chest is percussed and when a cold stethoscope is applied. If the mother holds the child over her shoulder and soothes him, it is often easier to perform a thorough chest examination. Light percussion can be more valuable than auscultation in some situations, but the basic signs are similar to those found in an adult. Breath sounds are usually harsh, high pitched and rapid. Any adventitious sounds present are pathological. Percussion of the chest may be helpful to pick up the presence of a pleural effusion (stony dull), collapse, consolidation of a lung (dull) or a pneumothorax (hyper-resonant). These pathological states are usually associated with an increase in the respiratory rate, as well as clinical signs of respiratory distress.

### Abdomen

In the infant the abdomen and umbilicus are inspected and attention should be paid to the presence of either a scaphoid abdomen, which in a neonate may be one of the signs of diaphragmatic hernia or duodenal atresia or a distended abdomen, which suggests intestinal obstruction, especially if visible peristalsis can be seen. Peristalsis from left to right suggests a high intestinal obstruction whereas one from the right to the left would be more in keeping with low intestinal obstruction. Any asymmetry of the abdomen may indicate the presence of an underlying mass. Abdominal movement should be assessed and abdominal palpation should be performed with warm hands.

Palpation of the abdomen should include palpation for the liver, the edge of which is normally felt in the new born baby, the spleen which can only be felt if it is pathological and the kidneys which can be felt in the first 24 hours with the fingers and thumb palpating in the renal angle and abdomen on each side. The lower abdomen should be palpated for the bladder and an enlargement can be confirmed by percussion from a resonant zone, progressing to a dull zone. In the baby with abdominal distension where there is suspicion of perforation and free gas in the abdomen, the loss of superficial liver dullness on percussion may be the only physical sign present early on. Areas of tenderness can be elicited by watching the baby's reaction to gentle palpation of the abdomen. There may be areas of erythema, cellulitis, and oedema of the abdominal wall and on deeper palpation crepitus can occasionally be felt from pneumatosis intestinalis (intramural gas in the wall of the bowel).

Auscultation of the abdomen in the younger patients gives rather different signs than in the adult. The infant even



**Fig. 1.6:** Ambiguous genitalia in a 10-year-old girl (clitoromegaly, labial fusion and empty scrotal folds of virilised female)

in the presence of peritonitis may have some bowel sounds present. However, in the presence of ileus or peritonitis breath sounds become conducted down over the abdomen to the suprapubic area and in even more severe disorders the heart sounds similarly can be heard extending down over the abdomen to the suprapubic area.

Perineal examination is important in both sexes. Examination of the anus should never be omitted. Occasionally the anus is ectopic, e.g. placed more anteriorly than it should be, stenotic or even absent. The rectal examination is an invasive procedure and should be carried out in a comfortable warm environment, preferably with the child in the left lateral position and the mother holding the hand of the child at the top end of the bed.

The testes in boys born at term should be in the scrotum. The prepuce cannot be and should not be retracted. It is several months or years before the prepuce can be retracted and stretching is both harmful and unnecessary. In girls the labia should be separated and genitalia examined.

The presence of a swelling in the scrotum or high in the groin may suggest torsion of a testis and requires urgent attention. The testis which cannot be palpated in the scrotum and cannot be manipulated into the sac indicates the presence of an undescended testis which needs to be explored and corrected before the age of 2 years. A swelling in the scrotum which has a bluish hue to it suggests the presence of a hydrocoele due to a patent processus vaginalis and one can get above such a swelling in most children. Palpation of the scrotum is initially for testes but if gonads are not present then palpation in the inguinal, femoral and perineal regions to determine presence of undescended or ectopic testes should be carried out.

Conditions, such as hypospadias, epispadias, labial adhesions or imperforate hymen or ambiguous genitalia should be diagnosed on inspection (Fig. 1.6).

## Limbs

Upper and lower limbs are examined in detail. Hands and feet should be examined for signs and those experienced in dermatoglyphics may define a finger print pattern which is consistent in various syndromes. The presence of a simian palmar crease may suggest trisomy 21 (Down's syndrome) and thumb clenching with neurological disease. The feet, ankles and knees should be examined for the range of movement in the joints and tone of the muscles. The femoral head may be outside the acetabulum at birth in true dislocation of the hip or it may be dislocated over the posterior lip of the acetabulum by manipulation, in which case the hip is described as unstable, dislocatable or lax. There are conditions in which the acetabulum is hypoplastic and shallow and the femoral head itself is distorted. Congenital dislocation of the hip is more common after breech deliveries in girls and in certain parts of the world. All newborn infants should be screened shortly after birth. The infant is placed supine with the legs towards the examiner and each hip is examined separately. The knee and hip of the baby are flexed to 90° and the hip fully abducted by placing the middle finger over the greater trochanter and the thumb on the inner side of the thigh opposite to the position of the lesser trochanter. When the thigh is in the mid-abducted position, forward pressure is exerted behind the greater trochanter by the middle finger. The other hand holds the opposite femur and pelvis steady. A dislocated femoral head is felt to slip over the acetabular ridge and back into the acetabulum as a definite movement. This part of the test is called the Ortolani manoeuvre. The second part of the test is the Barlow procedure. With the infant still on his back and the legs and hands in the same position the hip is brought into the position of mid-abduction with the thumb exerting gentle pressure laterally and posteriorly; at the same time the palm exerts posterior and medial pressure. If a hip is dislocatable the femur can be felt to dislocate over the posterior lip of the acetabulum. There is need for caution in performing this test and no force should be employed. Caution is particularly required in infants born with neural tube defects and paralysis of the lower limbs.

The knees, ankles and feet should be examined. Dorsiflexion of the feet should allow the lateral border to come in contact with the peroneal compartment of the leg. Failure indicates a degree of talipes equinovarus (TEV) which is of concern to the parents although with simple physiotherapy there are seldom long-term problems in the absence of underlying neurological abnormality.

## Spine

With the baby held face-downwards fingers should be run along the spine excluding spinal defects, such as spina bifida occulta and noting the presence of the common post-anal

dimple, a tuft of hair, a pad of fat and haemangioma. A Mongolian blue spot is commonly seen over the sacrum in Asian babies. The presence of a posterior coccygeal dimple or a sacral pit is common in babies and is due to tethering of the skin to the coccyx. When one stretches the skin and the base of the pit can be seen then nothing needs to be done about it. Very rarely there is communication with the spinal canal which could be the source of infection and cause meningitis.

### Stool and Urine Examination

Examination of a stool which is preferably fresh is often informative. The colour, consistency and smell are noted as well as the presence of blood or mucus. Urine examination is also important in children since symptoms related to the urinary tract may be nonspecific.

### Neurological Examination

The neurological examination of the young infant and child is different from that routinely carried out in the adult. Muscle tone and strength are important parts of the examination. In infants muscle tone may be influenced by the child's state of relaxation. An agitated hungry infant may appear to be hypertonic, but when examined in a cheerful post-prandial state the tone reverts to being normal. The examination of the neurological system cannot be complete without the evaluation of the child's development level relating to gross motor, fine motor and vision, hearing and speech and social skills. All older children should be observed for gait to detect abnormal coordination and balance.

Older children may be tested for sense of touch and proprioception as in adults. Tests of sensation as well as motor power must be performed in the paediatric patient, but are difficult to assess in the very young child. The normal newborn has a large number of primitive reflexes (Moro, asymmetric tonic neck, glabellar tap, sucking and rooting process). The "Moro-reflex" is a mass reflex, which is present in the early weeks after birth. Its absence suggests cerebral damage. It consists of throwing out of the arms followed by bringing them together in an embracing movement. It can be demonstrated by making a loud noise near the child. The "sucking reflex" is present at birth in the normal baby as is the "swallowing reflex". If the angle of the baby's mouth is touched by the finger or teat the baby will turn his head towards it and search for it. It is looking for its mother's nipple and is known as the "rooting or searching reflex".

The grasp reflex is illustrated by gently stroking the back of the hand so that the fingers extend and on placing a finger on the palm of the baby it takes a firm grip. Similar reflexes are present in the toes. If the baby is held up under the arms

so that his feet are touching a firm surface he will raise one leg and hesitatingly put it down in front of the other leg, taking giant strides forwards. This is the "primitive walking reflex".

Tendon reflexes, such as the biceps and knee jerks are easily obtainable but the ankle and triceps jerks are not readily elicited. Important as an indication of nervous system malfunction are muscle tone, posture, movement and the primitive reflexes of the newborn that have been described. Plantar reflex is usually extensor and is of little diagnostic importance in the first year. Delay in disappearance of the primitive reflexes suggests cerebral damage.

## A GUIDE TO EXAMINATION OF A CHILD-PATIENT

### Checklist of Bodily Systems

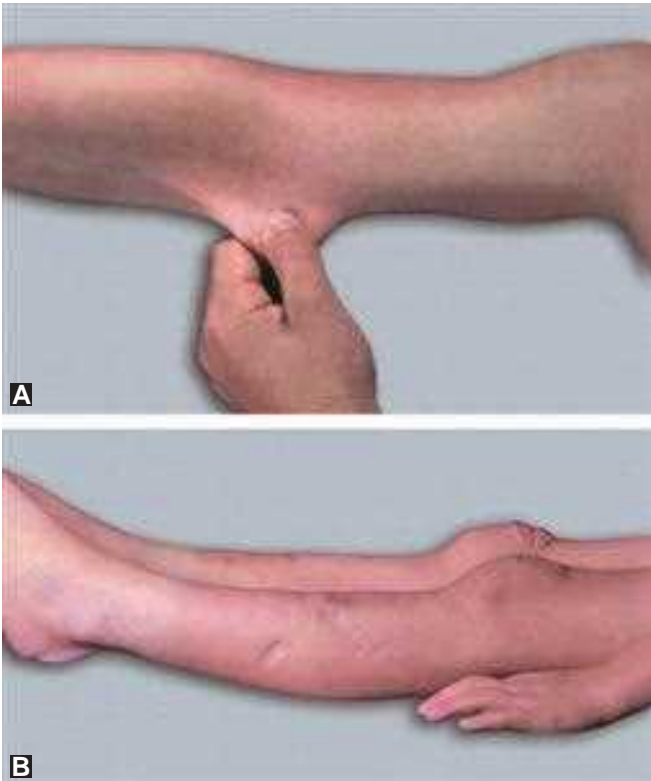
#### General Examination

- Is the child unwell, breathless or distressed?
- Level of consciousness
- Is the child cyanosed, pale or jaundiced (in carotinaemia the sclerae are not yellow)?
- ENT examination: Child's ears, nose and throat
- Is the child dehydrated?: Skin turgor, sunken eyes, sunken fontanelle
- Nutritional state
- Peripheral perfusion: Capillary refill time should occur within 2 seconds
- Does the child have any dysmorphic features, i.e. an obvious syndrome?
- Check blood pressure, temperature and pulses, i.e. radial and femoral
- Hands: For clubbing (look at all fingers), peripheral cyanosis, absent nails (ectodermal dysplasia), pitted nails (psoriasis), splinter haemorrhages (Fig. 1.7).

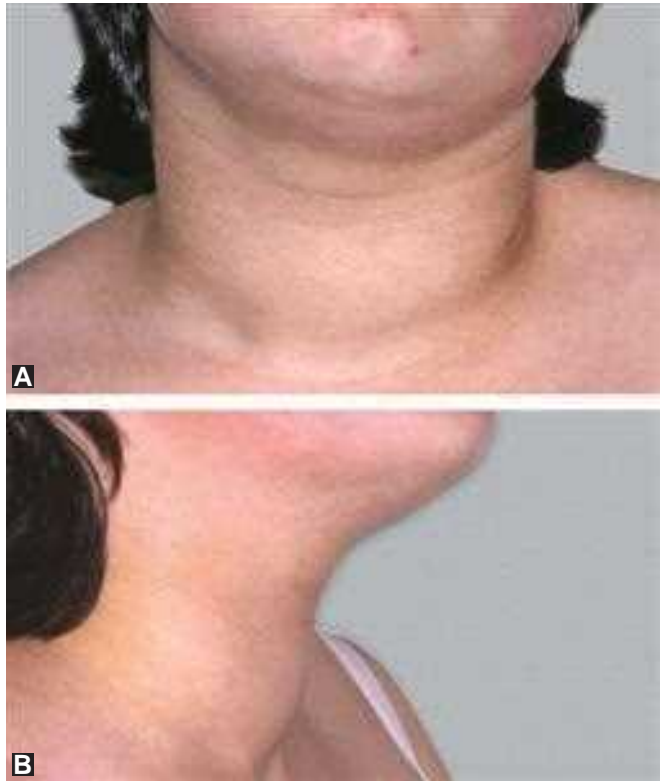


Fig. 1.7: Finger clubbing in cystic fibrosis





**Figs 1.8A and B:** (A) Hyperextensible skin and (B) Genu recurvatum in Ehlers-Danlos syndrome



**Figs 1.9A and B:** Goitre in Hashimoto's thyroiditis: (A) AP neck and (B) Lateral view neck

- Height, weight and head circumference (OFC): Plot these on a percentile chart
- Rash: Generalised or localised, bruises, petechiae, purpura, birth marks (learn dermatological terminology (Table 1.2))
- Abnormal pigmentation: Café au lait spots, Mongolian blue spots, elasticity of skin and hypermobility of joints (Figs 1.8A and B)
- Palpate for lymph nodes in the neck (from behind), axillae, groins any subcutaneous nodules
- Teeth: Any dental caries, a torn lip frenulum (physical abuse)
- Genitalia: Injuries to genitalia or anus—sexual abuse
- Head shape: Normal, small (microcephaly), large (macrocephaly), plagiocephaly, brachycephaly, oxycephaly (turricephaly). Feel the sutures. Is there evidence of craniostenosis?
- Hair: Alopecia, seborrhoea of the scalp
- Eyes: Subconjunctival haemorrhage, ptosis, proptosis, squint, nystagmus, cataract, aniridia, optic fundi
- Mouth: Thrush, fauces, tonsils, teeth, palate
- Ears: Normal, low-set, shape, pre-auricular skin tags
- Anterior fontanelle: Diamond shaped, open, closed, sunken, bulging, tense

- Head circumference: Measure the child's OFC and plot it on a growth chart (if not done under general examination).

### Neck

- Short, webbed (Turner syndrome), torticollis
- Thyroid: Enlarged, bruit
- Swellings:
  - Midline: Thyroglossal cyst, goitre (Figs 1.9A and B)
  - Lateral: Lymph nodes, branchial cyst, cystic hygroma, sternomastoid tumour.

## RESPIRATORY SYSTEM

### Inspection

- Use of accessory muscles of respiration
- Intercostal recession, any stridor, audible wheeze
- Shape: Normal, xpectus carinatum (undue prominence of the sternum-pigeon chest, pectus excavatum (funnel chest), Harrison's sulci, hyperinflation (increased anteroposterior diameter)
- Count the respiratory rate
- Scars of past surgery (look at the front and the back of the chest).

## Palpation

- Chest wall movement: Is it symmetrical?
- Feel the trachea: Central or deviated
- Tactile vocal fremitus (over 5 years of age—ask the child to say 99).

## Percussion

- Percuss all areas: Normal, resonant, hyper-resonant, dull (collapse, consolidation), stony dull (pleural effusion).

## Auscultation

- Air entry, vesicular (normal), absent breath sounds (pleural effusion) and bronchial (consolidation)
- Added sounds: Wheeze, inspiratory or expiratory, crackles (fine versus coarse), pleural friction rub
- Vocal resonance.

## CARDIOVASCULAR SYSTEM

### Inspection

- Are there features of Down's (ASD, VSD), Turner's (coarctation of the aorta), or Marfan's (aortic incompetence)
- Cyanosis: Peripheral and central
- Hands: Clubbing and splinter haemorrhages (endocarditis)
- Oedema: Praecordium, ankles and sacrum
- Praecordium for scars of past surgery.

### Palpation

- Pulses: Radial/brachial/femoral—radiofemoral delay (synchrony of the two pulses), rate
- Character of pulse—collapsing, volume
- Heart rate—rhythm
- Apex beat: Position (normal position in children 4th–5th left intercostal space in the mid-clavicular line), beware of dextrocardia
- Palpate for a parasternal heave and for precordial thrills.

## PERCUSSION OF THE HEART IS NOT NORMALLY UNDERTAKEN IN CHILDREN

### Auscultation

- Listen to all four valve areas (apex, lower L sternal edge, upper L sternal edge, and upper R sternal edge)
- Quality of heart sounds
- Additional sounds, i.e. clicks, murmur (timing of the murmur)
- Blood pressure—use a cuff that covers at least two-thirds of the upper arm or use Doppler.

## GASTROINTESTINAL SYSTEM

### Inspection

- General distension
- Superficial veins—direction of flow, striae, umbilicus
- Masses, scars, visible peristalsis.

### Palpation and Percussion

- First lightly palpate the entire abdomen, keep looking at the child's face all the time
- Localised tenderness, rebound tenderness and rigidity
- Masses
- Ascites—percuss for the shifting dullness
- Spleen, liver and kidneys
- Hernial orifices
- Genitalia (testes) and anus (site).

### Auscultation

*Bowel sounds:* Absence implies ileus.

## NERVOUS SYSTEM

- Level of consciousness
- Right or left handed
- Orientation, memory (past and present)
- Speech
- Posture.

## CRANIAL NERVE

- |         |   |
|---------|---|
| 1st     | Smell-ability of each nostril to different smells   |
| 2nd     | Visual acuity, visual fields, pupils (size, shape, reaction to light and consensual); Fundoscopy: papilloedema, optic atrophy, cataract   |
| 3rd     | Palsy: Unilateral ptosis, fixed dilated pupil, eye down and out   |
| 4th     | Palsy: Diplopia on looking down and away from the affected side   |
| 5th     | Palsy: Motor-jaw deviates to the side of lesion<br>Sensory: Corneal reflex lost   |
| 6th     | Palsy: Convergent squint  |
| 7th     | Facial nerve lesions: Weakness<br>Only the lower two-thirds is affected in UMN lesions, but all of one side of the face in LMN lesions. Ask the child to screw-up eyes, raise eyebrows, blow out cheeks, and show teeth |
| 8th     | Hearing, balance and posture  |
| 9th and |   |
| 10th    | Gag reflex: Look at palatal movement  |
| 11th    | Trapezii: Shrug your shoulders  |
| 12th    | Tongue movement: Deviates to the side of lesion   |

## Cerebellar Function

- Jerk nystagmus (worse on gaze away from midline)
- Truncal ataxia (if worse when eyes closed then lesion is of dorsal columns; not cerebellum)
- Intention tremor: Ask the child to pick up a small object and watch for tremor
- Past pointing: Ask the child to cover one eye with one hand and with the index finger of the other hand ask him to touch his nose and then touch your finger
- Gait: Ask the child to walk normally and then walk heel—toe look for ataxic gait.

## LOCOMOTOR SYSTEM

### Arms

- Tone, muscle bulk, muscle power—oppose each movement
- Joints: Hands swollen/tender metacarpophalangeal (MCP)/proximal interphalangeal (PIP) joints, test joints for hypermobility
- Reflexes: Biceps (C5, 6) and triceps (C7, 8)—compare both sides
- Hand: Ask child to squeeze fingers or spread fingers
- Coordination: Finger-nose touching
- Sensation: Test light touch.

### Legs

- Tone, quadriceps or gastrocnemius bulk
- Power—oppose each movement
- Coordination—rub heel up and down shin (“heel-shin test”)
- Joints: Swollen, tender, patella tap test (effusion in knee)
- Reflexes: Knee (L3, 4), ankle (S1, 2), plantar reflex—the plantar is normally up-going in infants until they begin to walk
- Feet: Any deformity are arches high or low.

### Sensation

- Joint position sense
- Fine touch discrimination.

### Gait

Ask the child to walk normally across room.

### Gower’s Sign

Ask the child to stand from supine. A child will normally sit up from lying, and then stand. In Duchenne muscular dystrophy, the child will have to roll over onto their front and then climb up their legs.

## DEVELOPMENTAL ASSESSMENT

This should be carried out under four headings: gross motor, fine motor and vision, hearing, and speech and social behaviour. These milestones are based for a child who is aged 6 weeks to 5 years.

### Birth to Six Weeks

#### Gross Motor

Marked head lag at birth on pulling to sit. By 6 weeks moderate head lag on pull to sit prone, brings chin momentarily off couch.

#### Fine Motor and Vision

- Can see at birth
- By 6 weeks, can fix and follow across to 90°.

#### Hearing and Speech

- Can hear at birth
- Startles and quietens to a soothing voice.

#### Social Behaviour

- Stops crying when picked up
- By 6 weeks, smiling to familiar noises and faces.

### Three to Six Months

#### Gross Motor

- By 3 months, on ventral suspension brings head above level of back
- Prone lifts head and upper chest off couch
- By 6 months, sits with support or tripod sits
- Beginning to weight bear. Rises to stand when supported.

#### Fine Motor and Vision

- By 3 months, holds hands loosely open and has hand regard
- By 6 months, reaches for toys with palmar grasp
- Transfers hand-to-hand and hand-to-mouth.

#### Hearing and Speech

- Can laugh, gurgle and coo
- Starts to babble around 6 months. Will turn when called.

#### Social Behaviour

- Holds on to bottle or feeding cup when fed
- Frolics when played with
- Examines and plays with hands and places feet in mouth.

## Six to Nine Months

### Gross Motor

- By 6 months can roll from front to back
- Sits unsupported with a straight back
- Begins to pivot around on arms and legs into the crawling position.

### Fine Motor and Vision

- Small objects picked up between index finger and thumb in a pincer grasp
- Transfers from hand-to-hand.

### Hearing and Speech

- By 9 months, shouts to gain attention
- Vocalises nonspecific syllables such as “dada” and “mama”.

### Social Behaviour

- Turns when talked to
- Resists when objects taken away
- Tries to reach for objects out of reach
- Likes to feed with fingers.

## Nine to Twelve Months

### Gross Motor

- By 9–10 months most infants are crawling
- Of 10% normal infants never crawl, but move around by rolling, padding or bottom shuffling. These children are often late walkers and may not walk alone until 2 years of age
- By 9–12 months, begins to pull to standing and cruise.

#### Key Learning Point

- ➡ Delayed walking could be due to the fact that the child is a bottom shuffler. There is a family history of bottom shuffling. It is autosomal dominant in inheritance. Rest of the developmental milestones is within the normal range.

### Fine Motor and Vision

- Will bang two cubes together
- Looks for fallen objects.

### Hearing and Speech

By 9–12 months, usually have 1 or 2 recognisable words in addition to “mama” and “dada”.

### Social Behaviour

- Enjoys imitative games, such as clapping hands and waving goodbye
- Shy with strangers until the end of the first year.

## Twelve to Eighteen Months

### Gross Motor

- By 12 months, can walk with hands held and begins to stand alone
- By 18 months, climbs onto chair and up stairs. Holds on to toys while walking.

### Fine Motor and Vision

- Pincer grip refined. Tiny objects can be picked up delicately
- Points at objects with index finger
- Can be persuaded to give objects to another on request
- Builds a tower of two or three bricks.

### Hearing and Speech

- Vocabulary of several words
- Comprehension is more advanced than speech at this age
- Enjoys looking at pictures on a book and points and babbles while doing this.

### Social Behaviour

- By 12 months indicates wants, usually by pointing
- Drinks from a cup and helps to feed themselves
- Begins to help with dressing
- Learns to throw
- Enjoys simple games such as peek-a-boo.

## Two Years

### Gross Motor

Can walk, run, squat and climb stairs two feet per step.

### Fine Motor and Vision

- Builds tower of six or seven cubes
- Spontaneous scribbling
- Hand preference
- Holds pencil with thumb and first two fingers
- Imitates vertical lines.

### Hearing and Speech

Uses 50 or more recognisable words and understands many more

- Forms simple sentences
- Carry out simple instructions.

#### *Social Behaviour*

- Feeds with a spoon, drinks from a cup
- Usually dry through day (variable)
- Demands mother's attention
- Tantrums when frustrated
- Instant gratification.

### **Three Years**

#### *Gross Motor*

- Climbs stairs one foot per step
- Pedals a tricycle
- Kicks a ball.

#### *Fine Motor and Vision*

- Copies a circle, imitates a cross
- Builds a tower of nine cubes
- Threads beads.

#### *Hearing and Speech*

- Speaks in sentences and may know a few colours
- Recites nursery rhymes
- Counts to 10.

#### *Social Behaviour*

- Eats with fork and spoon
- Dry through night
- Likes to help in adult activities
- Vivid imaginary play
- Joins in play with others.

### **Four Years**

#### *Gross Motor*

- Walks up and down stairs one foot per step
- May hop.

#### *Fine Motor and Vision*

- Copies cross (also VTHO)
- Draws a man with head, legs and trunks

- Picks up very small objects and threads beads
- Knows four primary colours.

#### *Hearing and Speech*

- Intelligible speech
- Knows name, address and usually age
- Listens to and tells stories
- Enjoys jokes.

#### *Social Behaviour*

- May wash, dress, undress, but not yet manage laces
- Understand taking turns, as well as sharing
- Appreciates past, present and future time.

### **Five Years**

#### *Gross Motor*

- Catches a ball.

#### *Fine Motor and Vision*

- Draws triangle and detailed man.

#### *Hearing and Speech*

- Clear speech.

#### *Social Behaviour*

- Comforts others
- Group play.

### **Primitive Reflexes**

- Rooting reflex: Appears at birth, disappears at 4 months
- Palmar/plantar reflex: Appears at birth, disappears at 4 months
- Stepping reflex: Appears at birth, disappears at 4 months
- Moro reflex: Appears at birth, disappears at 4 months
- Tonic neck reflex: Appears at 1 month, disappears at 6 months
- Delay in disappearance of the primitive reflexes suggests cerebral damage

# Growth and Development

## NORMAL GROWTH

Human growth is determined by an interaction of genetic and environmental factors. The infancy-childhood-puberty (ICP) growth model breaks down the human linear growth curve into three additive and partly superimposed components (Fig. 2.1). There are different growth promotion systems for each component. The infancy phase describes the period of rapid growth *in utero* and in infancy and this phase of growth is predominantly nutritionally dependent. Maternal nutrition before and during pregnancy are important determinants of foetal growth and low pre-pregnancy weight increases the risk of intrauterine growth retardation (OR 2.55). An additional intake of 300 Kcal and 15 g of protein per day are recommended for pregnant mothers above the recommended intake for non-pregnant women. Nutrient supply to the growing foetus is the dominant determinant in foetal growth, which is also dependent in placental function. Multiple approaches of nutritional intervention, control of infection and improved antenatal care to pregnant women are more effective than

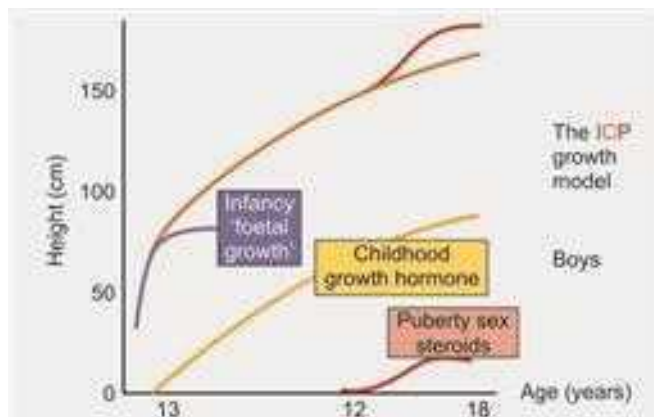


Fig. 2.1: Analysis of linear growth using a mathematical model (Courtesy: J Karlberg, et al. Acta Paediatrica Scand. 1987;76:478)

any single intervention. Nutritional deprivation during pregnancy can have an epigenetic effect on foetal growth extending over many generations. Studies from Netherlands have shown that maternal smoking and cannabis use in pregnancy results in significant foetal growth retardation, which is progressive through gestation. Cytokines are essential for implantation and insulin-like growth factor 2 (IGF-2) is important for placental growth. Apart from nutrition, hormones and growth factors have an important role in the control of foetal growth. Foetal insulin secretion is dependent on the placental nutrition supply and foetal hyperinsulinaemia, which stimulates cell proliferation and foetal fat accumulation from 28 weeks gestation onwards. Thyroid hormone, which affects cell differentiation and brain development, is also regulated by nutrition. Cortisol is essential for the pre-partum maturation of different organs including the liver, lung, gut and pituitary gland. Although growth hormone (GH) is important in post-natal growth, it plays an insignificant role in foetal growth except for an effect on foetal fat content. Animal knockout studies and human observations have shown that IGFs are most important for metabolic, mitogenic and differentiative activities of the foetus. Insulin-like growth factor-2 is more important in early embryogenesis. In humans, foetal body weight is more closely correlated with the concentration of foetal serum IGF 1 than IGF 2.

In the childhood phase of growth, hormones like growth hormone, thyroid hormone and growth factors like IGF begin to exert their influence from the end of the first year of life. A delay in the onset of the childhood phase of growth results in faltering of growth during this critical period. The growth faltering commonly observed between 6 and 18 months of life in children from developing countries are due to nutritional and socioeconomic factors rather than ethnic differences. The importance of the growth hormone and IGF 1 axis and other hormones in the childhood phase of growth is described in a subsequent section of this chapter.

Short-lived growth acceleration between 7 and 8 years of age can be observed in two-thirds of healthy children followed by a fall in growth velocity before the onset of puberty. The pubertal phase of growth is controlled by nutrition, health, GH-IGF 1 axis and pubertal secretion of adrenal androgens and sex steroids. The onset of the childhood component has been known to be positively associated with the magnitude of the foetal or infancy component. The height at onset of puberty is an important determinant of the final adult height. The onset of puberty component is negatively correlated with the height at onset of puberty.

The United Nations Children's Fund (UNICEF) has identified access to nutritionally adequate diet, health care for mothers and children, and environmental health factors as conditioning factors of child growth worldwide. The care required includes care of women in the reproductive age, breastfeeding and feeding practices, psychological care, food preparation, hygiene and home health practices. Low food intake and the burden of common childhood infectious diseases, diarrhoea, respiratory infections and infestations limit the full realisation of the genetic potential in children from developing countries. As more and more women join the workforce, their duration of time spent in child care and income generation determines whether child care is compromised. Quality child care is not affordable or accessible to low-income working mothers. Environmental pollution (air, heavy metals and smoking) can affect the growth of children especially those living in developing countries undergoing rapid economic transition. The negative effects of active and passive smoking in mothers on foetal growth and growth in early life have been well characterised. Environmental exposure to lead in children has been linked to impaired physical growth, neurodevelopment and delayed puberty. Mercury poisoning from industrial pollution and teething powder and drugs are less common. There are claims of association of increased mercury exposure with neurodevelopment deficits. No significant association of prenatal and postnatal exposure to methylmercury from fish consumption with childhood neurodevelopment has been found in populations with high fish consumption. A negative association between environmental sulphur dioxide, total suspended particulates and exposure to herbicide, and birth weight has been consistently reported in the literature. Impaired growth in infancy and childhood is associated with short adult stature and impaired cognitive development. The World Health Organisation (WHO) global database on child growth and malnutrition provides information on growth and nutrition worldwide ([www.who.int/nutgrowthdb](http://www.who.int/nutgrowthdb)) based on the National Centre for Health Statistic (NCHS)/WHO international growth reference. The prevalence of wasting in preschool children in Cambodia, Indonesia, Indian subcontinent, some island states in the Indian Ocean and some countries in Africa, and Middle East has remained above 10%. According to WHO, 110 million stunted children live

in Asia in 2005. With the improvement in socioeconomic conditions and healthcare in most countries, there is a dramatic secular increase in mean stature of populations from Asia and other developing countries, while the positive secular trends in growth have slowed or even plateaued in developed countries in Europe and North America.

Although, malnutrition remains a problem in some parts of the world, there is now a worldwide obesity epidemic in both developing and developed countries. The reason for the increase in body weight in children in the community is multifactorial including genetic, cultural differences and dietary changes especially increase in intake of high fat energy dense foods, but most importantly the increasing sedentary lifestyle adopted by different sectors of the population. The decrease in daily physical activity is due to mechanisation and computerisation. Time spent in watching television and playing or working on the computer is now regarded as a surrogate marker of inactivity in children. The health burden of excessive weight gain in childhood will be amplified in the years to come and urgent action by international organisations, governments and all national and region stakeholders is needed.

## ASSESSMENT AND MONITORING OF GROWTH

A clinician should take the opportunity to assess the growth of each child at each clinical encounter. The head circumference should be measured as the biggest circumference between the frontal region and the occipital prominence using a non-stretchable measuring tape. The body weight should be measured with a calibrated electronic scale, without shoes or socks and the child wearing light clothing. In infants and young children, the supine length should be measured with an infant stadiometer (Fig. 2.2). Children older than 2 years of age should be measured standing using a wall-mounted stadiometer (Fig. 2.3) without shoes or socks, with the eyes and external auditory meatus held in the same plane, and a slight upward pressure exerted on the jaw and occiput. The anthropometric measurements should be plotted accurately on the appropriate chart.

Monitor of growth in children and adolescents has been widely used by paediatricians as a marker of their general well-being. The normal pattern of growth in children is traditionally described in an up-to-date ethnic specific



Fig. 2.2: Stadiometer for measurement of supine length



**Fig. 2.3:** Wall mounted stadiometer for height measurement

growth chart. Growth references are valuable tools for accessing the health of individuals and for health planner to assess the well-being of populations. In a survey involving 178 countries, growth monitoring in the first six years of life is an integral part of paediatric care in most countries worldwide. Two-thirds of these countries use the NCHS or WHO growth reference, while more developed countries use their own national growth reference. In developing countries, health care workers monitor growth to detect and intervene when children have growth faltering. In developed countries, growth monitoring has been regarded as a useful tool for detecting unrecognised organic diseases, provision of reassurance to parents and for monitoring the health of children in the population. Understanding the ethnic differences in childhood and pubertal growth helps doctor in interpretation of results of surveillance of child growth based on the NCHS or WHO growth standard, which has a number of limitations. A WHO multicentre growth reference has been developed, based on a longitudinal study of exclusively breastfed children from birth to 24 months and a cross-sectional study of children from 18 to 71 months from six countries (Brazil, Ghana, India, Norway, Oman and the United States). Babies in the Euro-Growth study who were breastfed according to the WHO recommendations showed higher weight gain in the first 3 months of life and were lower in weight and length between 6 and 12 months as compared to the NCHS or WHO growth reference. No significant differences in growth from the NCHS reference in these children were noted between 12 and 36 months. The finding was similar to that of the WHO multicentre growth reference. The WHO multicentre growth reference

had completed [Acta Paediatr. 2006;95 (Suppl 450):1-106] and is considered as the gold standard for assessing growth of children worldwide.

Despite widespread acceptance of routine growth monitoring of children as the standard of care, a recent meta-analysis questioned the benefits of growth monitoring in childhood, as there have been very few trials that evaluated the impact of this practice on child health. Infants should be weighed at birth and at times of their immunisation. Surveillance of children's weight above one year is only recommended in children whose growth causes clinical concern. Clinicians should pay more attention to growth parameter collected during clinical consultations. Length measurement should only be done in children under 2 years of age, if there is a concern in their growth or weight gain.

In a normal population, less than 5% of the infants will drop their weight through two centile lines and less than 1% of infants will have a fall in weight across three centile lines in the first year of life. A baby would be regarded as failing to thrive, if there is a fall in weight across more than two centile lines in infancy. In the United Kingdom, it has been recommended that primary care physicians should refer children for assessment, if their heights falls below the 0.4th percentile (-2.67 SD) and a single height measurement at school entry using this criteria that has been found to be a sensitive marker for undiagnosed organic disease. The sensitivity of this recommended height screening test can be improved by making a correction for the height of the parents. Height measurements taken during other clinical encounters during childhood are further opportunities for referral using the 0.4th percentile as the cut-off for action. Clinicians have long placed a lot of emphasis on growth assessment using height velocity, which is calculated from the difference between two height measurements, thereby combining the imprecision of the two readings. Successive measurements of height over time in an individual are highly correlated, whereas successive annual growth velocities are not. This suggests that growth velocity estimates are not reliable and does not have a useful role in routine growth monitoring. Despite its imprecision, a grossly abnormal growth velocity can still be regarded as an indicator of disease. Whether routine height screening every 2–3 years between 5 and 12 years of age will be cost-effective in detecting silent disease without the capacity to cause harm within the paediatric population remains to be proven. However, routine monitoring of the height and weight in both developing and developed countries is likely to continue in the years to come.

In the monitoring of overweight and underweight, both the WHO and the International Obesity Task Force (IOTF) have suggested the use of different body mass index [BMI derived from weight (kg)/height<sup>2</sup> (in meters)] cut-offs for



identifying these problems in the clinical and public health setting. The WHO has adopted the updated BMI reference based on the United States NHANES I data collected in 1971–1974 ([www.cdc.gov/growth\\_charts](http://www.cdc.gov/growth_charts)), while IOTF has adopted an international BMI reference derived from six population growth studies (Cole TJ et al. *BMJ*. 2000;320:1270) as the gold standard for international comparison. The WHO proposed a BMI below the 5th percentile, above 85th percentile and 95th percentile as cut-offs for underweight, overweight and obesity respectively. The IOTF established BMI percentile cut-offs at different ages based on extrapolation of adult BMI cut-offs of 25 kg/m<sup>2</sup> and 30 kg/m<sup>2</sup> for overweight and obesity. In addition, national BMI references are now available in many developed countries. The cut-offs based on the United States reference data are related to some measures of morbidity, but the newly developed IOTF BMI cut-off points for children still require validation with data on morbidity measures like blood pressure, serum lipids, insulin resistance and diabetes. In a meeting organised by WHO or International Association for the Study of Obesity (IASO)/IOTF in Hong Kong in 1999, the experts were of the opinion that a lower BMI cut-offs might need to be set for adult Asian populations because of their predisposition to deposit abdominal fat. The proposed revised BMI cut-off is 23 kg/m<sup>2</sup> and 25 kg/m<sup>2</sup> for overweight and obesity respectively ([www.idi.org.au](http://www.idi.org.au)).

### THE GROWTH HORMONE: IGF 1 AXIS

The pulsatile secretion of growth hormone from the pituitary gland is under the control of the stimulatory action of growth hormone releasing hormone (GHRH) and the suppressive effect of somatostatin. Multiple neurotransmitters and neuropeptides are involved in the hypothalamic release of these hormones. Growth hormone is essential for normal human growth in childhood and adolescence. The liver is the organ with the highest GH receptor concentrations and is the main source of GH binding protein (cleaved extracellular portion of the GH receptor) found in the circulation. After binding to its receptor and inducing dimerisation, GH activates the JAK2/STAT pathway to bring about the stimulation of epiphyseal growth, osteoclast differentiation, lipolysis and amino acid uptake into muscles. The more important growth promotion action of GH is mediated by IGF 1. Circulating IGF 1 comes predominantly from the liver and is associated with IGF binding protein 3 (IGFBP 3) and the acid labile subunit (ALS) to form a ternary complex. The action of IGF 1 is modified by six binding proteins in the circulation. Although IGF 1 is important in foetal growth, serum concentration of IGF 1 is low in foetal life and in early infancy. A significant rise in IGF 1 and IGFBP 3 concentrations is observed in normal children from 10 months onwards. There is further progressive rise

of serum IGF 1 to two to three times of the adult serum concentrations as the children progress through puberty. The serum IGF 1 level in childhood is also dependent on nutrients availability. It has now been shown that the local generation of IGF 1 in tissues in response to GH rather than the circulating IGF 1 is essential for normal growth; liver-specific IGF 1 knockout mice have low circulating IGF 1 levels and yet they have near normal growth. Short stature has been reported in humans with mutations in the genes of GHRH, GH, GH receptor, STAT5b, IGF 1, ALS and IGF 1 receptor.

### GENETICS OF STATURE

Fisher RA proposed in 1918 that many genetic factors, each having a small effect, explain the heritability of height. This is still true in the genome era. From five genome wide association studies using single nucleotide polymorphisms analysis, investigators have identified over 50 chromosome locations (implicating nearby genes), which appear to be partially responsible for the regulation of adult stature in humans. Collectively, these genes account for about 4% of adult stature. One gene LIN28B on chromosome 6q21 which is shown to be important in the determination of stature is also found to be associated with the age at menarche. Heterozygous carriers of mutations of natriuretic peptide receptor B (NPR2) have a mean height of  $-1.1 \pm 0.8$  SD and the carrier frequency is 1 in 5–700 and some short children may be NPR2 mutation carriers. Heterozygous insulin-like growth factor acid labile subunit gene (IGFALS) mutation carriers have  $-0.9 \pm 1.51$  SDS loss in height compared with the normal population. It is possible that carriers of some of these single gene defects can be the cause of some short children in the population. It is likely that more and more height determining genes will be described in future.

### PUBERTY

Puberty is defined as the maturational transition of an individual from the sexually immature state to adulthood with the capacity to reproduce. The hypothalamic-pituitary-gonadal axis is active *in utero* and at birth. After this period of activation, the axis undergoes a long period of relative quiescence from 3 to 6 months after birth until late childhood when pubertal development occurs. The onset of puberty is the result of decreasing sensitivity of the regulatory system of gonadotropin secretion (gonadostat) in the hypothalamus to the negative feedback of the small amounts of gonadal steroids secreted by the pre-pubertal gonads, as well as a decrease in the central neural inhibition of gonadotrophin releasing hormone (GnRH) release. Disruption of genes controlling the migration of GnRH neurons from the olfactory

epithelium to the forebrain can result in delayed puberty. The initiation of puberty is associated with a decrease in trans-synaptic inhibition by GABAergic neurons and an activation of excitatory glutamatergic neurotransmission in the control of GnRH secretion. There is also evidence that glial to neuron signalling through growth factors is important in the neuroendocrine control of puberty. Evidence for genetic regulation of the timing of puberty is suggested by the correlation of the age of onset of puberty in mother and their offsprings and also in twin studies. It has been suggested that 50–80% of the variance in pubertal onset may be genetically controlled. Kisspeptin, which is encoded by the *KISS 1* gene on chromosome 1q31, is cloned as a tumour metastasis suppressor gene. Kisspeptin-G protein coupled receptor 54 (GPR54) signalling complex is important in the control of puberty. Inactivating GPR 54 mutations lead to hypogonadotropic hypogonadism and an activating mutation of GPR54 has been described in a girl with slowly progressive precocious puberty. Genomewide association studies (GWAS) and age at menarche (AAM) identified a significant association of *LIN28B* and AAM. A meta-analysis of 32 GWAS identified 30 loci associated with AAM and these genetic loci explained 3.6–6.1% of the variance in the AAM, equivalent to 7.2–12.2% of its heritability.

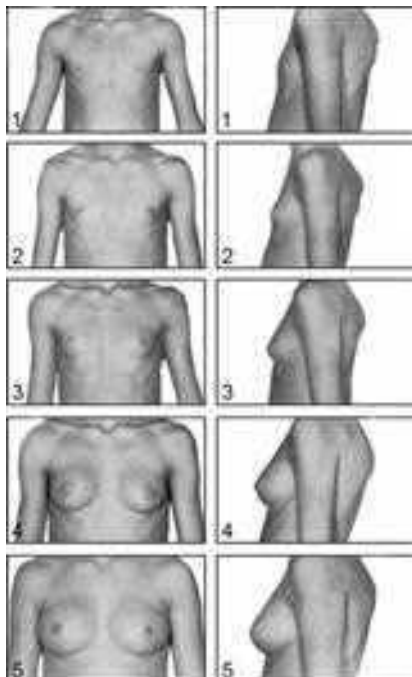
Light dark rhythm and climatic conditions have little effect on the AAM. Children adopted from developing countries to live in a developed country have early puberty as a general rule. Exposure to endocrine-disrupting chemicals can affect timing of puberty and, for example, isomers of DDT have oestrogen agonistic and androgen antagonistic effect. Mycoestrogenic zearalenone was reported to be elevated in 35% of girls with central precocious puberty in a study from Italy. Zearalenone is a nonsteroidal mycotoxin produced by *Fusarium* species on grains and causes contamination of grains and animal feeds. Brominated flame retardant and dichlorodiphenyl-dichloroethylene (DDE) have been found to have an association with earlier puberty in girls. The timing of puberty is also influenced by nutrition and metabolic cues. A direct relationship between a particular ratio of fat to lean body mass and onset of puberty has been described. Leptin plays a role in informing the brain of peripheral energy stores and body composition and may act as a permissive signal for the onset of puberty.

With the onset of puberty, there is increasing pulsatile secretion of luteinising hormone (LH) and to a lesser extent follicle-stimulating hormone (FSH), mainly at night through gradual amplification of GnRH pulse frequency and amplitude. In pubertal boys and girls, sleep-entrained pulsatile GnRH secreted every 60–90 minutes progressing to become more regular throughout the day. In boys, the pulsatile gonadotropin secretion stimulates the testes

to develop and the Leydig cells to produce testosterone. Testosterone production increases progressively and is responsible for the metabolic changes and the development of secondary sexual characteristics. Both LH and FSH are required for the development and maintenance of testicular function. In early puberty in girls, circulating FSH level increases disproportionately to the LH level in response to GnRH stimulation. Gonadotropin stimulation leads to a rapid rise in ovarian oestrogen production before menarche. When the concentration of oestradiol rises above 200 pg/ml for a few days, the negative feedback on GnRH and gonadotropin release turns to positive feedback leading to the ovulatory LH surge. In humans, the ability of the hypothalamus to stimulate gonadotropin secretion in response to positive feedback effects of oestrogen does not occur until after menarche. In adult females, the GnRH pulse frequency starts at 90 minutes in early follicular phase, increases to one pulse every 60 minutes in mid-follicular phase and slows to one pulse every 4–6 hours in the luteal phase.

From the age of 6–8 years onwards, there is a progressive rise in adrenal androgens secretion up to 20 years of age. This process of maturation of the adrenal gland, referred to as adrenarche, is responsible for pubic and axillary hair development and this event occurs independent of the maturation of the hypothalamic-pituitary-gonadal axis, although the timing of the two processes are usually related in normal puberty. Adrenarche is coincident with the mid-childhood adiposity rebound and there is evidence that nutritional status measured as a change in the body mass index (BMI) is an important physiological regulator of adrenarche.

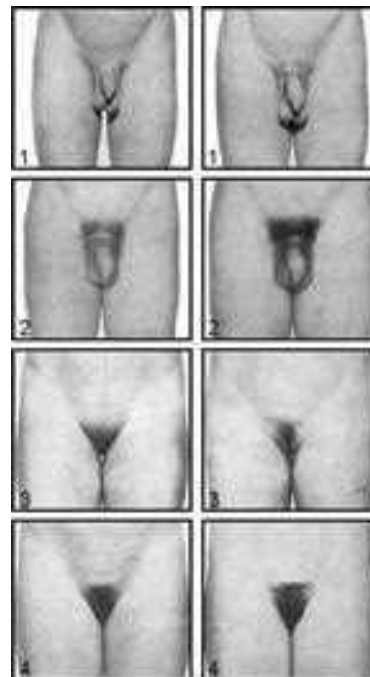
The progressive changes in the secondary sexual characteristics have been described in a standardised format by Tanner (Figs 2.4 and 2.5). There is considerable variation in the age of onset and the tempo of progression of puberty among normal children. Over the last century, children have tended to be taller in stature and reach sexual maturity at an earlier age. In a recent population study from the United States, 5% and 15% of the white and African American girls had breast development before the age of 7 years. Since the mean age of menarche in these American girls have not changed significantly over time, puberty in American girls is associated with earlier onset of breast development, but with a slower tempo of pubertal progression. An age of onset of puberty before the age of 9 years in boys and before 7 years in girls is regarded as premature. Girls and boy without signs of puberty by the age of 13 years and 14 years should be monitored carefully and considered for evaluation of delayed puberty. The mean age of onset on menarche can vary from 11.2 years in African Americans, 11.27 years in China and 13.4 years in Denmark.



**Fig. 2.4:** Standards for breast development (From Tanner, 1969) (Courtesy: Endocrine and Genetic Diseases of Childhood and Adolescence by Gardner, Lytt.I. WB Saunders Company. 1975)

## CHILD DEVELOPMENT

Development in children is predominantly determined by genetic factors, but a significant contribution comes from environmental factors (maternal nutrition during pregnancy, birth, socioeconomic factors, nutrition and health after birth). Intellectual development in childhood and adolescence is a complex and dynamic process with the interaction between genes and the environment continuously changing over time. Antenatal and postnatal depression, maternal malnutrition, maternal smoking during pregnancy, antenatal exposure to organic pollutants and adverse child care practice can disrupt the development of different psychomotor domains in infancy and childhood. Home environment, parent-child relationship, parenting style and discipline practices and school environment can have a major influence in the socioemotional and cognitive growth of an individual in childhood and adolescence. Traditionally, early childhood development can be described in stages in four functional skill areas: gross motor, fine motor, language and speech, social and emotional development. It is also important for paediatricians to be familiar with the development of the special senses, like hearing, vision, taste, smell, sensation and proprioception. Timing of achievement of major milestones in the various domains of development can vary enormously in normal children. Sound knowledge of development in



**Fig. 2.5:** Standards for pubic hair ratings in boys and girls (From Tanner, 1969) (Courtesy: Endocrine and Genetic Diseases of Childhood and Adolescence by Gardner, Lytt.I. WB Saunders Company. 1975)

childhood and adolescence allow us to recognise global or specific developmental delay beyond the normal acceptable age, disordered developmental sequence or developmental regression.

## GROSS MOTOR DEVELOPMENT

Motor development progresses in a cephalocaudal direction with suppression of primitive reflexes and development of postural tone and secondary protective reflexes. The primitive reflexes including the Moro, grasp, stepping and asymmetric tonic neck reflexes must have disappeared by 3–6 months of age before head control (4 months) and independent sitting at 6–8 months can occur. Prior to walking, an infant can crawl on all four limbs, bottom shuffle, commando creep or roll along the ground. Shufflers, creepers and rollers tend to attain independent walking at a later age than infants who crawl on all fours. Thus early locomotor patterns can result in significant variation in the age of achieving independent walking. A delay in walking beyond 18 months of age is a warning sign in children who have been crawling as the early locomotor pattern. An infant stands holding on furniture by 9 months of age, cruise round furniture by 12 months and walk independently by 13–15 months. At 18 months of age, a child can climb onto a chair and walk up and down stairs two feet per step by 24 months of age. By two and half years of

age, a child should be able to stand on tip-toes, jump on both feet and kick a ball. A 3-year-old child can walk backwards and can ride a tricycle. There is further development of gross motor skill and balance with age and most children can participate in a variety of activities like swimming, skating, gymnastics and ball games by 6–7 years of age.

### FINE MOTOR DEVELOPMENT IN EARLY CHILDHOOD

The development of fine motor skills in childhood is condition upon the development of normal vision. Voluntary movements and fine motor manipulations require the co-ordinated development of nervous system and visuomotor coordination. Visual fixation can be demonstrated in babies by 4–6 weeks of life. The grasp reflex is usually inhibited by 3 months of age and babies can be seen to open their hands, clasp and unclasp their hands at the midline of the body. Between 3 and 5 months, babies find their hands interesting and persistence of “hand regard” beyond 5 months is unusual. By 6 months of age, babies can reach and grasp an object (one inch cube) with the palm of their hands (palmar grasp). Putting objects to the mouth is a common activity at this age. Transfer of objects from one hand to the other can be seen at 6 months. By 9 months of age, babies can hold a cube in each hand and bring them together for comparison. Grasping of small objects with the thumb and index finger (pincer grasp) can be achieved between 9 months and 12 months. Casting of objects is frequently observed towards the end of the first year of life, but voluntary release of an object on command only takes place at 15 months. By 15 months of age, a child can hold a pen in his/her palm and scribble. The child can build a tower of 2–3 cubes between 15 and 18 months. At 2 years of age, a child’s ability to manipulate small objects continues to improve (Fig. 2.6). Hand dominance can be observed at 2 and half years of age and the child can scribble and draw a line or circle with a tripod pen grip. At 3 years of age, a child can build a tower of 8 to 9 cubes and copy building patterns using three to four cubes. A child can eat with a fork or spoon. By 4 years, a child can draw a man showing body parts and copy some alphabets. Between 5 and 6 years, a child can write well and eat properly with knife and fork.

### LANGUAGE AND SPEECH DEVELOPMENT IN CHILDHOOD

Language can be defined as an arbitrary set of symbols, which when combined in a particular sequence, allows an individual to convey a specific message or conceptualisation and transmit them to another individual. When the transmission of messages between individuals is performed

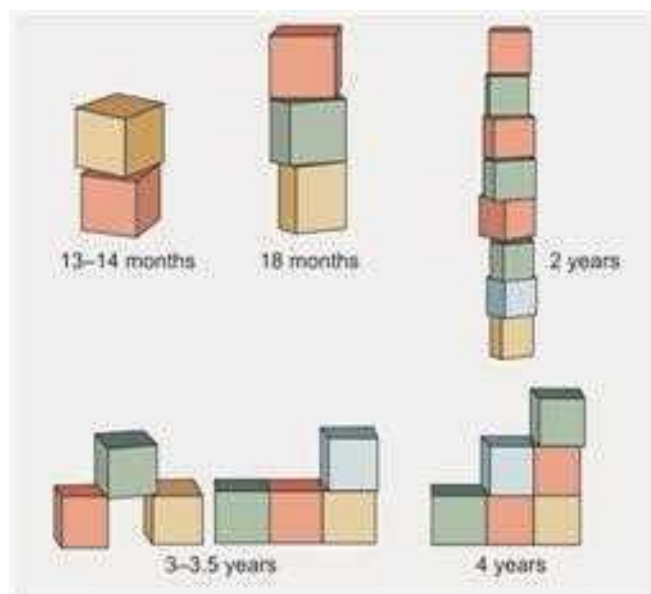


Fig. 2.6: Build cubes

verbally, then the action is referred to as speech. Language acquisition is a complex process integrating interaction between many factors. Genetic factors possibly play an important role early in the developmental process, but neurological (cerebral palsy, neuromuscular disorders, hearing impairment, autism), cognitive (mental retardation, specific learning disabilities and specific developmental language impairment), environmental (psychosocial deprivation, bilingual or multilingual environments, cultural differences, maternal depression and large sibship) factors are important determinants of speech development. Impaired hearing is associated with impairment in language and speech development and the prevalence of severe hearing loss has been estimated to be between 1:900 and 1:2500 in newborn infants. It has been shown that universal newborn hearing screening, using auditory brainstem response (ABR) or two-step screening (ABR-ABR) and otoacoustic emissions (OAE), enables the early identification of infants with moderate to severe hearing impairment. There is evidence that early diagnosis of impaired hearing and intervention can be associated with a better-improved language and communication skills by 2–5 years of age. Cochlear implant is an alternative for children with severe sensorineural hearing loss who do not benefit from conventional hearing-aids. Early cochlear implantation before 3 years of age has been associated with a better outcome in terms of speech and language development as compared to children receiving cochlear implants in later life.

A one-month-old baby startle to sound, but location of the source of sound presented at ear level is present at 6 months

of age. At 3 months, they respond to the call of their names, smile and laugh or are comfortable in response to the sound of the mother's voice. Babies can make consonant sounds at 3 months of age (e.g. ba, ka and da) and deaf infants are usually referred to as quiet babies at this stage. Babbling in strings usually occur after 6 months of age. At 12 months of age, the baby understands some simple commands and uses increasing variety of intonation when babbling. At one year of age, an infant understands simple commands like "blow a kiss" or "wave bye-bye". They are able to say a few words with meaning and have at least 6 recognisable words with meaning by 18 months. At 18 months of age, they can name body parts on request and start to use word combinations. By 2 years of age, children have a vocabulary of many words and can speak in simple sentences. A 9-month-old child can look for an object after being hidden, demonstrating their grasp of the concept of object permanence. Before the development of expressive speech, infants of one year age can indicate their desire by pointing or gesture. They demonstrate definition by use of common objects like cup, brush, comb and spoon. Symbolisation occurs at 18 months with the child imitating the mother's household chore or feeding a doll. Between 18 months and 22 months, children can engage in constructive symbolic play with toys of miniature.

Both expressive and receptive language involves three important aspects, namely, phonology and articulation, semantics and syntax. The coordinated neuromuscular mechanisms, which produce the desired sequence of phonemes, constitute expressive phonology. The neurological process involved in the identification of the phonemes in a spoken message is referred to as receptive phonology. Semantics refers to the process involved in relating a spoken word to its meaning. In most cases, a thought cannot be expressed simply by a single word. In constructing a spoken message, syntax governs the particular order of words as they appear sequentially in speech. Syntax also governs the use of tense, plurality, grammar and the relationship between the different words. Syntactic process works in conjunction with the semantic process in deriving the meaning conveyed by a sequence of words. The use of two to three word combinations in young children involves the omission of function words, which are used in the more complex adult speech. The simple word combinations also reflect the reduced memory capacity of young children. By 3 years of age, a child can use plurals, pronouns and prepositions (e.g. under, behind, in front of) in their speech. Most young children are disfluent, but a child should be wholly intelligible and have few infantile substitutions or consonant substitutions at the age of 4 years. As children become older and with experience, they incorporate new rules and expand rules already acquired, in such a fashion that their speech becomes progressively a

close approximation to the syntactic structure characteristic of adult speech. After the age of 6 years, children are able to engage in a long conversation with family members and their peers. They can perform simple tasks in command. At 7 years of age, children are able to express their thoughts in speech and writing.

As the number of children raised in bilingual or multilingual families increases, paediatricians should have some knowledge of the normal patterns of bilingual language acquisition. A child may acquire two languages simultaneously with an initial undifferentiated simple language composed of elements from both languages. By 2–3 years of age, the child begins to be able to differentiate the two languages. The child can use the appropriate language when speaking to a particular person or in a particular environment (e.g. home or school). Normal children in bilingual families can also acquire the two languages in a sequential manner. In this situation, the first or dominant language is acquired first in the usual manner and then the children develop an understanding of the second language drawing on the experience with the first language. There may be a period of selective mutism before the child can switch from one language to the other proficiently. Bilingualism may contribute to delay in language development, but is not a cause of disorder of language or cognitive development. Parents should be consistent in setting the boundaries for where each language is spoken.

## SOCIAL DEVELOPMENT

By 4 weeks of age, babies show social smile in response to the caregiver and enjoyment to cuddling, bathing and the voice of the mother. At 6 months of age, a baby is able to finger feed and is more wary of strangers. A child can drink from a cup with help and enjoy songs and nursery rhymes at 9 months of age. They also desire a comfort object (like a soft toy, cloth or blanket) and become anxious when they are separated from their caregivers (separation anxiety). Babies can play pat-a-cake or wave bye-bye and show affection to family members towards the end of the first year. At 18 months, they can feed themselves with a spoon and they can feed themselves properly using knife and fork at 4 years. The age of achievement of bladder and bowel control is variable, but is usually towards the end of the 2nd year of life, but bedwetting at night can persist into mid or late childhood. Beyond 2 years of age, children are increasingly mobile and are curious and interested in exploring their environment. They can help with dressing and bathing. They can manage to use the toilet independently by age of three years. At the age of 4 years, they can groom and dress themselves and brush their teeth. At age of 18 months, children are

contented to play by themselves; at 2 years of age they still play alone or alongside other children (parallel play). At 3 years of age, they start playing with other children and start making friends. They share toys and develop the concept of being helpful to others.

## EMOTIONAL AND COGNITIVE DEVELOPMENT

Soon after birth, a baby demonstrates a keen interest in human faces and voices. They also become aware of other sensations like hunger and noxious stimuli and respond to unpleasant sensations by crying. Even at one month, a baby exhibits different dimensions of behaviour like activity, placidity, irritability, excitability and anger regulation that is commonly referred to as temperament. Infants with different temperament are at increased risk of behavioural problems in later life. The bonding of a baby with the parents depends on the baby's temperament and the personality, sensitivity and caring nature of the parents. At 6 months of age, a baby already becomes aware of the emotional state of the parents or caregiver through their actions and their voices. Secure attachment relationship between infant and mother, and to a certain extent, with fathers and caregivers is established towards the end of the first year of life. Secure mother-infant bonding buffers a baby against the short-term influence of adverse psychosocial effects in childhood development. By one year of age, infants start to develop their own sense of identity. They have fluctuating moods, occasionally throw temper tantrums, but also show affection towards familiar people. In the next 2–3 years, young children become increasingly aware of other people's intentions and desires and emotions. They begin to show empathy (comfort a crying baby). They are inquisitive and constantly ask questions. They recognise primary colours (30 months) and begin to grasp the concept of numbers and time. They play and communicate with other children. They have increased memory capacity, and reasoning and problem solving skills. They can remember and give an account of past events. Children learn by observing and experiencing repeated stimuli and social situations, imitating, and experimenting with speech and actions. They apply a set of concrete rules for exploring and interacting with the outside world. Their ability to appreciate logical arguments improves with age. They become aware of their body image and develop self-esteem. Their self-concept becomes differentiated and they begin to realise that they are not always competent in different developmental domains. During middle childhood, children further develop their fundamental skills of reading, writing, mathematics, long-term memory and recall. They are able to comprehend complex instructions. Significant amount of learning

is acquired during the school hours. Adolescence is the period of transition from childhood to mature adulthood with physical maturation and acquisition of reproductive capability and socioeconomic and independence from the family. With the increasing number of young people entering into tertiary education, this period of adolescent development has been lengthened in the developed world. Adolescents become increasingly competent in logical and scientific reasoning and these abilities are reflected in their ability to analyse and solve problems in mathematics and science and formulate arguments and opinions in different fields of study. They are able to think in abstract terms and develop an understanding of issues like responsibility, morality, peer relationships and sexuality.

## DEVELOPMENT ASSESSMENT

A comprehensive child health assessment would not be complete without a proper developmental history, examination and assessment of emotion and mental well-being of the child. To obtain a developmental history of children ask the parents open-ended questions and to elaborate on developmental concerns, if any, and provide them examples of their concerns. A paediatrician should be able to identify “developmental red flags” (Table 2.1), developmental delay, disordered developmental sequence and developmental regression. Observations and interactive assessment in different developmental domains (gross motor, fine motor, visuospatial coordination, language and speech, emotion and social behaviour, cognition, hearing and vision) should be carried out. After assessment, a profile of developmental abilities and difficulties should form the basis for the necessity of referral for multidisciplinary specialist assessments by developmental paediatrician, psychologist, speech, physiological and occupational therapists.

**Table 2.1:** Developmental “red flags” in infancy and early childhood

- No visual following by 8 weeks and poor eye contact
- Uncoordinated eye movements with head turning after 3 months
- Persistent fistling (especially with thumbs adducted across the palms beyond 3 months)
- No head control by 6 months
- Not sitting independently by 10 months
- Unable to walk alone at 18 months
- No pointing to show demand or interest by 14 months
- No words with meaning by 18 months
- Not joining two words by 30 months
- Features of pervasive developmental disorders (compulsive and ritualistic activities, severe language delay, poorly developed social relationship, abnormal attachment to inanimate objects, inappropriate affect and tantrums, developmental delay)

Intelligence tests have been used to assess the innate cognitive ability, and to indicate deficiencies of different domains of development in a child who is struggling and under achieving in school. The Wechsler Intelligence Scale for Children (WISC III and IV) is one of the most widely used intelligence quotient (IQ) tests and has been translated into many languages and validated. Some Wechsler subtests do not require skills in English and may be used to address referrals of non-English speaking children for certain developmental problems. The tests provide four index scores reflecting verbal comprehension, perceptual reasoning, working memory and processing speed. An IQ test is the first step towards the assessment of specific learning disabilities and the provision of support and intervention for children with difficulties in schools. A high IQ score, however, does not guarantee future success in life. Children with an uneven developmental profile on IQ testing requires further specialist neuropsychological

assessment using specialised test instruments for memory, visuospatial skills, language, attention, motor skills, social cognitive and planning and execution of tasks.

In recent years, there is increasing demand for paediatricians to develop skills in dealing with children with behavioural and emotional disorders. Measurements of behavioural and emotional well-being and adjustment in children and their family members can be achieved using the child behaviour check list (CBCL) for parents, teachers and older children. Paediatricians should be aware of common presentations of such disorders and have some knowledge of neuropsychological test instruments for the assessment of childhood depression, anxiety, obsessive-compulsive, attention deficit hyperactivity disorders and eating disorders and conduct disorders. These conditions have been discussed in greater details under the different chapters of this book.

# Neonatal Paediatrics

## INTRODUCTION

Neonatal medicine has made great progress in the last few decades with increased survival of preterm babies, and is now focusing its effort to improve the quality of the survivors. Administration of antenatal steroids to mother with threatened labour below 34 weeks of gestation, surfactant administration, availability of trained personnel, and improved temperature control at birth, benchmarking, sharing of good practice has changed the face of neonatology. Babies are born in better condition and survival has improved significantly.

However, there remains a lot to be done to make this care universally available. Neonatal mortality (death during first 4 weeks of life) still remains high in low and middle income countries and there is a need for effective strategies to address this. Majority of these deaths could be prevented by simple measures like improved care at delivery, early treatment of sepsis in newborn babies, administration of tetanus toxoid to mother, and the promotion of breastfeeding. Also important is to educate the parents about hygiene, maintaining adequate temperature and when to seek medical attention. This chapter is intended to give a general overview of common neonatal conditions and its management.

## NEONATAL RESUSCITATION

Although the vast majority of babies do not need any help at birth, some do. Although there may be warning signs, some babies are born unexpectedly in poor condition. It is therefore important that all personnel involved in the delivery and management of the newborn baby are well versed in basic resuscitation. A person trained in advanced resuscitation should be readily available. If the delivery of a compromised baby is anticipated, a team of experienced clinicians should get to the delivery suite in advance and check the equipment is in working order. Discussion should take place with the obstetrics team to obtain the necessary antenatal information like presence of foetal distress and likely gestation of the

baby. They should introduce themselves to parents and explain the reason for their attendance at delivery.

Animal studies have demonstrated that at the onset of acute hypoxia, baby's breathing becomes rapid and deep and heart rate and blood pressure increases. If the insult continues, baby will enter into primary apnoea, with an immediate drop in heart rate probably vagally mediated. If the insult continues, gasping respiration at a rate of 12 per minute mediated by spinal centres results, and the heart rate will continue to fall and the baby becomes pale. If the acute insult is not halted, the baby will enter into terminal apnoea with further fall in heart rate, with the heart rate eventually stopping. During this process, there will be change in blood pressure, carbon dioxide and oxygen levels. The measurements of these are not available in "labour room acute emergencies". Fortunately, they are not needed for decision-making in neonatal resuscitation. Doctors need to assess only respiratory effort, heart rate, tone and colour of the baby to assess the need for resuscitation and this is reassessed at 30 seconds interval to check the response to resuscitation.

The colour of the baby is only really important, if the baby is pale after delivery.

If the baby is born apnoeic, it is difficult to tell whether it is primary or secondary apnoea, however, irrespective of which, the resuscitation sequence is the same and effective. It is important to document baby's condition at birth, presence or absence of gasp and the response of the baby to the resuscitation measures. Although Apgar score is widely used, it is not very useful in the immediate decision for resuscitation. Moreover, certain factors like prematurity, maternal sedation and general anaesthesia may affect the scoring. Traditionally, Apgar score is recorded at 1, 5 minutes and subsequently at 5 minutes interval. If it is obvious that the Apgar score is low secondary to maternal sedation or general anaesthesia, it should be clearly documented.

Babies are born wet from warm intrauterine environment to relatively cold dry environment geared towards the mother. Therefore, babies can lose heat very quickly. The



babies who are cold have increased oxygen requirement and are difficult to resuscitate. They are more likely to develop metabolic acidosis and respiratory distress from surfactant deficiency. They lose heat through conduction, convection, radiation and evaporation. To minimise the heat loss to place the baby on warm surface (reduce heat loss through conduction), keep the windows and doors closed (to prevent heat loss through convection), keep the surroundings as warm as possible (to prevent heat loss through radiation) and dry the baby, remove the wet towel and cover with warm towel (mainly to reduce heat loss through evaporation). Most babies start breathing spontaneously and do not need any further intervention. There is no need to routinely suction the nose or oropharynx of these babies, they should be wrapped in warm towel and given to the mother.

If the baby is not making any spontaneous respiratory effort or has poor colour, dry and cover the baby and covering in warm towel, position the head in a neutral position. Assess the colour, tone, respiratory effort and heart rate. If the baby is not making any respiratory effort or heart rate is low or absent, give five inflation breaths. The inflation breaths are at 20 cm water pressure, each lasting for 2–3 seconds to open the lungs and displace the lung fluids. It is important that an appropriate sized mask is used. The initial one or two breaths may not show chest movements. With successful air entry into the lungs the baby's heart rate will improve first then the colour. If subsequent breaths do not produce chest movements, check the baby's neck position, reassess the technique, mask size and seek for help early rather than late. There is no point in doing chest compressions, if effective breaths are not given. If the problem persists and doctors are not able to get chest movements, consider "two person technique"—one person holding the mask with jaw thrust and another giving the inflation breaths or the use of an appropriately sized guedel airway. Only after getting good chest movement, chest compression be considered.

After inflation breath, reassess the baby. If baby is making good respiratory effort, has good colour and heart rate is above 100, wrap the baby in warm towel and give him or her to mom. If the baby's colour and heart rate is good but not making good respiratory effort, continue ventilation breath at the rate of 40 per minute. Ventilation breath should be long enough to produce chest movements. The poor respiratory effort may be related to maternal sedation, opiate administration or general anaesthesia for caesarean section.

If in spite of good chest movements with inflation breath, heart rate and colour does not improve; consider chest compression if heart rate is less than 60 per minute. The purpose of chest compression is to achieve oxygenation of the heart through the supply of oxygenated blood to the coronary arteries to perfuse the heart. This is in contrast to

adults, where cardiac compression is aimed at maintaining blood supply to brain. Newborn's heart is healthy and any bradycardia or asystole is usually due to a respiratory problem or absent heart sounds is secondary to respiratory failure. This is the reason why there is no point in starting chest compressions unless chest expansion is achieved.

The heart rate and chest compression should be alternated at the ratio of 3:1. Although recommended chest compression is 120 per minute and respiratory rate is 40 per minute, it is difficult to achieve these rates under emergency situation even by those experienced in resuscitation. It is the quality of the resuscitation, which is more important than the number. Therefore a lower rate may be acceptable provided it is effective. Reassess the baby after 30 seconds of each intervention as the babies usually respond within 20 seconds.

Some babies may not respond to the above measures and need medications, but it is very rare. It is important that secure airway is established—sometimes by intubation, ensuring chest movements and effective cardiac compressions.

Only a small number of drugs are used in neonatal resuscitation—adrenaline, 4.2% sodium bicarbonate and 10% dextrose. The resuscitation should continue and access should be obtained. It is easier to obtain central venous access in neonatal period through the umbilical vein. Adrenaline in the dose of 10 micrograms per kilogram (0.1 ml/kg of 1:10,000) should be administered followed by normal saline flush. If venous access is not available, higher dose of 100 micrograms per kg may be given through endotracheal tube. Continue cardiopulmonary resuscitation and reassess after 30 seconds, if the baby does not show any response, administer sodium bicarbonate 4.2% (2 ml/kg) followed by adrenaline 30 micrograms per kg (0.3 ml/kg of 1:10,000). The administration of sodium bicarbonate is to correct the acidosis in the myocardium allowing for its responds to adrenaline. It may also be useful to give 10% dextrose 2.5 ml/kg through umbilical venous line to correct any hypoglycaemia.

If volume loss has occurred from maternal haemorrhage, normal saline bolus 10 ml/kg or uncross-matched O Rhesus, negative blood may need to be infused. Sometimes, in spite of all efforts, the baby may not survive. Generally, if after effective resuscitation of 10 minutes, there is no response, resuscitation may discontinued. The decision to discontinue the resuscitation measures should be taken by the most senior clinician available. It is helpful to have cord blood gas during resuscitation.

If a baby has had prolonged or significant resuscitation or the sequence of resuscitation requirements and presents with gasps agonal respiration they should be admitted to the neonatal unit for close observation. They are at high-risk of developing hypoxic ischaemic encephalopathy and seizures.

The baby should be started on antibiotics if infection is suspected. Renal and hepatic functions should be monitored closely. As they are at risk of renal impairment and syndrome of inappropriate secretion of ADH, fluids may need to be restricted. Blood glucose, hypocalcaemia, hypomagnesaemia and hyponatraemia should be corrected as appropriate. If the baby develops seizures, they should be treated with anticonvulsants like phenobarbitone, phenytoin, lorazepam. Elevated temperature should be avoided.

Some babies may qualify for “total body cooling” therapy to improve survival and neurodevelopmental outcome. Every baby who needs resuscitation should be carefully assessed to see whether they meet the criteria for “total body cooling”.

Most importantly clear documentation of the sequence of events at resuscitation cannot be overemphasised. Parents should be updated and counselled regarding the prognosis particularly for long-term outcome.

Unsuccessful resuscitation can be very stressful to the team and therefore de-briefing at a later date to go over the resuscitation to learn and improve. Date is a very useful exercise.

## HYPOXIC ISCHAEMIC ENCEPHALOPATHY

Most babies require little or no help at birth and will go on to have a normal transition into the neonatal period. A small percentage of those who receive significant resuscitation develop hypoxic ischaemic encephalopathy. There are many predisposing factors, including postmaturity, cord prolapse and maternal conditions like abruption placenta, antepartum haemorrhage, uterine rupture, etc. As discussed in the previous section, a baby who is acutely asphyxiated will go through a period of primary apnoea into terminal apnoea, if the hypoxic insult is not terminated early. The antenatal cardiotocograph (CTG) recording during labour may give valuable information prompting early intervention. The abnormalities include foetal bradycardia, tachycardia and decreased variability. In these situations, the foetal scalp pH helps in decision-making. If time permits the neonatal team should be present during the delivery ensuring adequate help and preparation.

In the face of acute asphyxia, nature initiates the dive reflex this diverts blood away from nonessential organs to the brain, heart and adrenal glands. This is called the dive reflex. If the insult continues, the brain will ultimately be affected. Some babies may not show any dive reflex and develop an encephalopathy with no dysfunction in the kidneys or liver. It is important to remember that the sequence of events described may be different in a baby who is chronically compromised but develops a secondary acute insult.

Any baby who needs significant neonatal resuscitation should be admitted to the neonatal unit for observation.

Depending on the severity, clinical manifestations will differ. It may be mild (Sarnat stage 1), moderate (Sarnat stage 2) or severe (Sarnat stage 3). In Sarnat stage 1, the baby is usually hyper-alert with predominant sympathetic activity. In Sarnat stage 2, the baby develops seizures, and may be hypotonic with parasympathetic over-activity. In Sarnat stage 3, baby is in a very poor condition and often comatose. It is very important to document the neurological status at the time of admission and regularly thereafter.

These babies are at risk of seizures, renal failure, hepatic dysfunction and syndrome of inappropriate secretion of ADH. Fluid should be restricted to 40–60 ml/kg per day and blood glucose should be maintained. Hyperthermia should be avoided. If facilities are available, cerebral function monitoring should be done to assess the severity of cerebral dysfunction.

The baby should be examined to document the neurological findings and suitability for therapeutic cooling (total body cooling). The need for continued resuscitation at 10 minutes of age, Apgar score of less than 5 at 10 minutes, cord base deficit of 16 or more and abnormal cerebral function recording are some indications for therapeutic cooling. Cranial ultrasound scan may give more information like any intracranial bleed and abnormal cerebral resistance index.

Baby should be started on antibiotics if infection is suspected—bearing in mind that a baby who is infected might not have been able to cope with the stress of labour thus developing the hypoxic ischaemic encephalopathy. Any electrolyte abnormality including hypocalcaemia and hypomagnesaemia should be corrected. If the baby is significantly affected, feeds are generally withheld for 24–48 hours and started only if baby is stable and making progress. This is to prevent the risk of necrotising enterocolitis (NEC) in a gut that has experienced decreased blood flow.

These babies should have a magnetic resonance imaging (MRI) scan of the brain and an electroencephalography (EEG) usually during the 2nd week of life. MRI scan may show abnormality in the basal ganglia, highlighting of the posterior limb of the internal capsule and also cerebral cortex.

They should be followed up in the neurodevelopmental clinic. They benefit from multidisciplinary input from speech and language therapist, physiotherapist, occupational therapist, ophthalmologist and community paediatrician.

Parents should be kept informed throughout the neonatal course and discussions should be on-going with regard to long term process. The uncertainty as to the extent of any neuro should be highlighted. If the baby is severely compromised with significant brain injury and neurological outcome is expected to be extremely poor, withdrawal of intensive care should be considered and discussed with the

parents and members of neonatal team. It is also a good practice to obtain second independent opinion before care is withdrawn. It cannot be overemphasised that the decision-making process is clearly documented in case notes.

## WHOLE BABY HYPOTHERMIA

Moderate induced hypothermia (cooling) to a rectal temperature of 33 – 34°C improves survival and neurological outcomes to 18 months of age in infants with moderate to severe perinatal asphyxia encephalopathy. The BAPM and NICE guidelines 2010 recommend that babies presenting with moderate to severe neonatal encephalopathy within the first few hours after delivery should undergo therapeutic cooling and that all infants who are cooled should be entered on the TOBY register. All infants who undergo therapeutic cooling should have a formalised developmental assessment at 2 years of age.

### Clinical/Eligibility Criteria

Infants with evidence of moderate to severe perinatal asphyxia HIE (hypoxic ischaemic encephalopathy) according to the following inclusion criteria:

- Age:  $\leq 6$  hours of age.
- Gestational age at birth:  $\geq 36$  weeks.
- Evidence for foetal acidemia.
  - Apgar score  $\leq 5$  at 10 minutes after birth.
  - Blood gas (cord or within first hour of life): pH  $< 7.0$  with base deficit  $\geq 16$ .
  - Continue need for active resuscitation at 10 minutes of age (including endotracheal or mask ventilation) and or need for external cardiac massage, adrenaline during resuscitation.
- Evidence of moderate to severe encephalopathy based on clinical features
  - Altered state of consciousness (reduced or absent response to stimulation) and
  - Abnormal tone (focal or general hypotonia, or flaccid) and

- Abnormal primitive reflexes (weak or absent suck or moro response).

The criteria for defining moderate and severe encephalopathy are listed in Table 3.1.

### Contraindications to cooling treatment include:

- Life limiting congenital abnormality or abnormalities indicative of a poor long term outcome.
- Moribund infant with persisting severe encephalopathy such that further treatment is likely to be futile – reorientation of care following initiation of cooling should be considered as a reasonable option following necessary detailed assessment and wide consultation with parents and other health care professionals.
- Infant requiring imminent or immediate surgical treatment during the first 3 days of life.

### Indication for discontinuing cooling before 72 hours of treatment:

- Infant with normal aEEG in the subsequent 6 hours after initiation of cooling and clinical signs consistent with mild neonatal encephalopathy.
- Moribund infant with severely abnormal signs of neonatal encephalopathy including aEEG features in whom death or severe neuro-disability is the inevitable outcome.

All standard monitoring specific to the care of an infant receiving intensive care should be maintained up to at least 24 hours after re-warming of the infant.

### Methods of Initiating and Maintaining Cooling

During whole body cooling the target rectal temperature of 33-34°C for 72 hours, followed by slow rewarming over 12 hours to 37.2°C (normothermia).

### Passive Cooling

- This may be undertaken following resuscitation and prior to transfer to the Neonatal Unit where active cooling should be carried out.

**Table 3.1:** The criteria for defining moderate and severe encephalopathy

Parameter	Moderate encephalopathy	Severe encephalopathy
Level of consciousness	Reduced response to stimulation	Absent response to stimulation
Spontaneous activity	Decreased activity	No activity
Posture	Distal flexion, complete extension	Decerebrate
Tone	Hypotonia (focal or general)	Flaccid
Suck	Weak	Absent
Moro	Incomplete	Absent
Pupils	Constricted	Constricted
Heart rate	Bradycardia	Variable
Respiration	Periodic breathing	apnoea

- Commence continuous rectal or axillary temperature monitoring.
- Turn off incubator or open thermal cot, open portholes.
- Adjust covering (blankets) or consider use of fan if temperature outside target temperature.

### Active Cooling

- Carried out using appropriate cooling machine.
- Servo control mode is preferred.
- Manual control mode may be used in exceptional situations.

### Re-warming

- To be commenced after 72 hours (or earlier if clinical circumstances dictates).
- The rectal temperature should be allowed to rise by no more than 0.2-0.3°C per hour to 37 ±0.2°C.
- The infant's temperature must be monitored for 24 hours after normothermia has been achieved to prevent rebound hyperthermia that might be detrimental.

## Support Care

### Ventilation

The need for mechanical ventilation may be required.

### Cardiovascular Support

- Alternations in heart rate and blood pressure are common during cooling; the heart rate is reduced and blood pressure increased with reduction in body temperature. Most infants with rectal temperature of 33-34 (the target rectal temperature for whole body cooling) will have a heart rate around 100 bpm and a mean blood pressure >40 mmHg.
- A rapid rise in body temperature may cause hypotension by inducing peripheral vasodilatation.
- Causes of hypotension should be sought and appropriate treatment given. Treatment with volume replacement and/or inotropes should be considered if mean arterial blood pressure is <40 mmHg.

### Analgesic and Sedative Therapy

- The signs of distress include tachycardia, facial grimacing and irritability. A heart rate consistently above 100 bpm in cooled infants suggests that the infant is distressed.
- Ventilated babies may be sedated with intravenous morphine, maximum loading dose 50 microgram/kg over 30 minutes followed by 10-20 micrograms/kg/hour. Morphine may need to be discontinued after 24-48 hours to lessen the risk of accumulation and toxicity.

- Non-ventilated infants who appear distressed should be sedated with chloral hydrate, 50 mg/kg with respiratory monitoring.

### Management of Seizures

Phenobarbitone is first line, followed by Phenytoin and then Midazolam.

## ROUTINE NEWBORN EXAMINATION

All new born babies should have get their first examination 6-12 hours after birth preferably after 24 hours. This is an opportunity to pick up any life-threatening conditions. It is also to reassure the parents that baby is normal or to explain any abnormal findings. Many times doctors might have had warning about abnormalities noticed during antenatal scans or by the nursing staff in the labour room. It is important to review the maternal notes for any risk factors for sepsis like maternal pyrexia during labour, prolonged rupture of membrane (> 18 hours) or preterm labour. Mother's high vaginal swab may be positive for Group B streptococci (GBS). Examine the notes for maternal serology for syphilis, hepatitis B, HIV and immunity for rubella as well as blood group and any setting for Rh or ABO isoimmunisation. Any family history of inherited disorders, neonatal deaths and developmental dysplasia of hip should be noted.

It is a good practice to speak to (obtain from) the nursing staff looking after the mother and baby, if any concerns they may have. Generally babies pass meconium during first 24 hours and urine in first 48 hours. If they have not, they should be carefully assessed to rule out any renal or gastrointestinal abnormalities.

Examination of newborn is straightforward but clinicians need to be flexible during the assessment examining area that will upset the baby last to use the opportunities. Most of the congenital anomalies are found around the natural openings. Apart from the examination of systems, look for any cleft lip and palate, absence of red reflex, ano-rectal and spinal abnormalities. It is important to palpate for femoral pulses as weak or absent femoral pulses may be an indication of coarctation of aorta or hypoplastic left heart syndrome.

When the newborn's eyes are examined with an ophthalmoscope, the retina glows giving rise to the red reflex. If it is absent, it indicates cataract or other abnormality in vitreous or tumour (retinoblastoma). These babies should be reviewed by an ophthalmologist at the earliest. In some babies, particularly of Asian descent the retina may appear pale. If in doubt, it should be reviewed by a senior clinician or an ophthalmologist.

If the baby has a murmur, it is a good practice to obtain the oxygen saturations in the lower limbs. If the saturations are above 96%, serious congenital heart defect

is unlikely. However, review by a more senior paediatrician is recommended. This is reassuring to parents and nursing colleagues.

If a cleft palate is detected, look carefully for any associated anomalies and assess the feeding and breathing. Most of these babies will manage to feed well but involvement of cleft palate team which includes plastic surgeon, speech and language therapist, dietician and nurse who help to coordinate the child's management until cleft palate repair is corrected.

Examination of the hips is also very important. Developmental dysplasia of hip is more common in female infants, those born by breech presentation and on the left side. Before examination, make ensure that nappy is removed and baby's pelvis is on the bed. First look for leg length discrepancy and then gently abduct the hips. If the full abduction is possible on both sides, there is no dislocation. Next step is to look for hip stability. First fix the pelvis by placing thumb over pubic symphysis and fingers over sacrum (use left hand if you are checking right hip and vice versa). Now grasp the knee joint in the palm of the hand and place thumb over lesser trochanter and middle finger over greater trochanter. Gently adduct the thigh at hip and push it posteriorly. If the hip is unstable, head of the femur will move out of the joint—Barlow positive. Now gently abduct the thigh by gently pulling it forward. If the head of the femur moves out of acetabulum during Barlow's test, it will move back into the joint with a clunk. It is called a positive Ortolani manoeuvre. These babies should have an ultrasound scan of the hip joint and review by an orthopaedic surgeon. Most of these cases are managed by splints like Von Rosen's.

Some of the common findings noted include undescended testes, preauricular tag, haemangioma, Epstein pearls on the hard palate or gums, hypospadias, positional or fixed talipes equino varus, erythematous rash (erythema toxicum, a benign condition) and sacral dimple.

Unilateral undescended testis does not need any intervention. Normally, it descends by 6 months of age, if not, it should be referred to surgeons. If it is bilateral, the baby should be reviewed by a senior paediatrician to confirm it and to investigate further note that a phallus may be an enlarged clitoris. Similarly, any ambiguity of genitalia should be investigated immediately. Congenital adrenal hyperplasia which may cause virilisation of female could be a life-threatening condition if not recognised early and treated. These should have chromosomal analysis, ultrasound scan of the abdomen and inguinal region to look for gonads and uterus, blood glucose for hypoglycaemia and electrolytes (hyponatraemia and hyperkalaemia in congenital adrenal hyperplasia).

Hypospadias should be assessed for its severity (coronal, penile and penoscrotal) and for the presence of chordee. If there are no associated anomalies, the baby should be referred to a surgeon and parents should be advised against

circumcision. In cases of sacral dimple, examine to see whether the bottom of the pit is visible and for the presence of any neurological abnormality. If the bottom of the pit is not visible, the baby should be referred an ultrasound scan of the lumbosacral region to rule out the tethered cord.

Female neonates may have vaginal bleed from withdrawal of maternal hormones and also vaginal mucosal tag is a benign finding and parents need reassurance.

## PERINATAL INJURIES

Through improved obstetric care, the incidence of birth injuries, has declined but still occur. The types and severity of the injuries vary depending on the cause of and the process of the difficult delivery. Conditions like multiple gestations, abnormal presentations like cephalopelvic disproportion and large babies, increase the risk of birth injuries. Certain genetic conditions like osteogenesis imperfecta are also associated with multiple fractures at birth or thereafter.

Common minor injuries seen are caput succedaneum (soft tissue swelling of the presenting part, which usually disappears within few days after birth), cephalohaematoma (subperiosteal bleeding, common on the parietal region, does not cross midline,) usually appears after delivery and may persist for several days to weeks. Application of the ventouse may produce soft tissue swelling called chignon but on rare occasions subaponeurotic or subgaleal haemorrhage. If the haemorrhage is severe, it may result in severe blood loss, shock and death. Other injuries of the presenting part may include injuries from scalp electrodes, abrasions and bruises. Incision wounds may occur during caesarean section.

Application of forceps may be associated with injury to the facial nerve resulting in 7th cranial nerve palsy. This may manifest in the form of deviation of angle of mouth to the opposite side. It usually recovers spontaneously within days to weeks but may take longer. Rarely, it may leave residual weakness of the face on the affected side. Management involves preventing exposure keratitis and reassurance to the parents.

Another relatively common injury is brachial plexus injury from shoulder dystocia, injury to C5 and C6 results in the typical waiter's tip position—of adduction, internal rotation at shoulder and extension of elbow (Erb's palsy), but with preservation of grasp. Usually it is transient and recovers spontaneously. Physiotherapy is usually recommended. If there is no improvement within a few weeks the children are referred to the brachial plexus injury clinic (a combined service of orthopaedics, neurology and physiotherapy). The main thrust of management is to prevent imbalance between different muscle groups and maximise the function of the limb. Rarely, extensive damage may include C8 and T1 alone (Klumpke's palsy) or together with C5 and C6. Involvement

of C8 and T1 will result in weakness and paralysis of small muscles of hand. The diaphragm on the same side too may be affected. Other uncommon injuries include fracture of clavicle, humerus and skull.

## MECONIUM ASPIRATION SYNDROME

Meconium stained liquor is a relatively common occurrence with no significant adverse effect but some babies can develop meconium aspiration syndrome—meconium aspiration, respiratory distress and chest X-ray changes. This is one of the dreaded complications due to risk of persistent pulmonary hypertension of the newborn (PPHN). Meconium aspiration syndrome is commoner in babies born postterm and in babies with foetal distress. There is no evidence to support suction of the baby's mouth and oropharynx at the perineum before the shoulder. If the baby is born in a good condition and is crying, no suction is needed. However, if the baby is in a poor condition or not making any respiratory effort, the oropharynx and the vocal cords should be suctioned under direct vision before starting intermittent positive pressure ventilation. These babies should be closely monitored and preferably admitted to the neonatal unit for observation.

It is important to maintain high oxygen saturation in these babies to prevent development of the PPHN. It is acceptable practice to start antibiotics after obtaining blood culture. Chest X-ray may show patchy opacification with air trapping. These babies are also at risk of pneumothorax. This is due to the "ball valve" effect of meconium depending on the severity of the clinical picture. They may require mechanical ventilation, incubator oxygen, head box oxygen, intubation and ventilation and inhaled nitric oxide. Many clinicians administer surfactant may be required for secondary surfactant deficiency resulting from the effect of meconium. Blood gases should be monitored for CO<sub>2</sub> retention and hypoxia, while acidosis should be corrected as it may worsen the pulmonary hypertension. If the baby is on inhaled nitric oxide, methaemoglobin should be monitored. Oxygenation index is particularly useful to assess the response progress and the need for extracorporeal membrane oxygenation (ECMO). The current ECMO practice with the use of venovenous cannulation has reduced the neurological complications compared to arteriovenous cannulation used previously. When facilities are not available for nitric oxide or ECMO, prostacyclin, magnesium sulphate infusion may be used as pulmonary vasodilator. The baby may also need other supportive measures like inotropes for hypotension, correction of coagulation abnormalities and electrolyte abnormalities.

If facilities are available echocardiogram should be performed to prevent the error of wrongly labelling underlying serious cardiac conditions like hypoplastic left

heart syndrome or cyanotic congenital heart disease as PPHN from meconium aspiration syndrome. It is also helpful for monitoring the response to inhaled nitric oxide therapy by assessing the degree of tricuspid regurgitation.

It is important to remember that babies with meconium aspiration syndrome may have been compromised *in utero* and are risk of developing hypoxic ischaemic encephalopathy. There are trials comparing the outcome for babies who are cooled during ECMO compared to babies who were not cooled during ECMO.

## TRANSIENT TACHYPNOEA OF THE NEWBORN (OR 'WET LUNG')

This is a relatively common condition in babies born by elective caesarean section due to a delayed resorption of lung fluid into the pulmonary lymphatic system, this is normally facilitated by passage through the birth canal and up regulation of some hormonal activity. Most of these babies will improve during first few days of life but some develop significant respiratory distress needing incubator oxygen, continuous positive airway pressure (CPAP), intubation and ventilation. Chest X-ray may show fluid in the horizontal fissure with increased bronchovascular markings.

## CYANOTIC CONGENITAL HEART DISEASE

Although congenital heart disease is not very common, it is important to recognised it early and start appropriate management.

In foetal life, the gas exchange takes place in the placenta and the oxygenated blood is carried by umbilical vein to the right atrium through ductus venosus and inferior vena cava. Some of this blood is diverted across the foramen ovale to left atrium. The remaining blood with superior vena caval return enters right atrium. The left ventricular output mainly supplies head, neck and upper part of the body. The right ventricular output is largely diverted to the descending aorta through the ductus arteriosus. The descending aorta supplies the lower part of the body and also gives rise to umbilical arteries which carry blood to placenta. Once the baby is born, the lungs aerated, and the pulmonary vascular resistance falls and blood flow to lung increases. The ductus arteriosus, foramen ovale and ductus venosus closes (Fig. 3.1).

However, if the pulmonary vascular resistance does not fall as expected, the baby will develop PPHN, similar to some babies with meconium aspiration syndrome.

Congenital heart disease may be acyanotic with left to right shunt [atrial septal defect (ASD), ventricular septal defect (VSD) and persistent ductus arteriosus (PDA)]. This is unlikely to create a major clinical problem in the

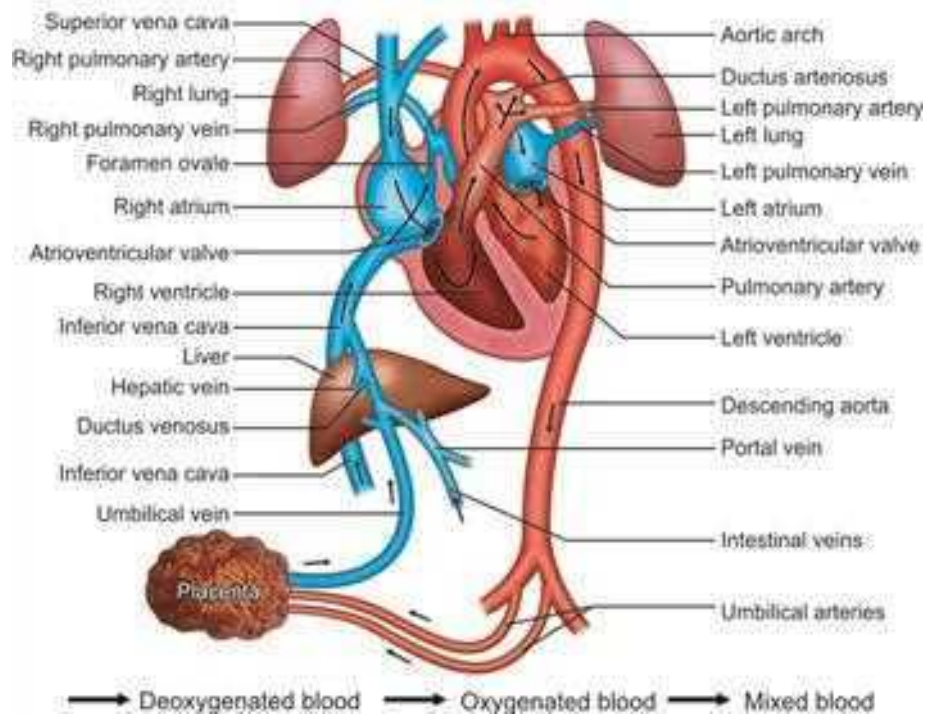


Fig. 3.1: Schematic representation of the foetal circulation

neonatal period as the pulmonary vascular resistance is high and shunt across the defect is not significant. In cyanotic congenital heart disease, there is a mixing of oxygenated and deoxygenated blood causing cyanosis. The mixing can occur if there is a communication between left and right side of the heart through ASD, VSD or PDA. If there is no ASD or VSD, mixing will depend on PDA. If the PDA closes, the baby will become very unwell and may die. This group of congenital heart disease which require PDA for the baby's survival are called duct-dependent cyanotic congenital heart diseases—transposition of great arteries is an example. If it is suspected, the diagnosis should be confirmed by echocardiography and baby started on prostaglandin infusion to maintain the ductal patency. The administration of oxygen should be avoided as this may result in ductal closure. Some clinicians accept saturations as low as 70%, provided baby is not very unwell and acidotic. Once the baby is stable, should be transferred to cardiac centre for further management. Sometimes, balloon septostomy is carried out to allow the mixing of blood at atrial level so that closure of ductus will not compromise the baby and definitive surgery is done later.

Another important cardiac condition is hypoplastic left heart syndrome where, left side of the heart is poorly developed. The systemic circulation is maintained by shunting across ductus arteriosus from right ventricular output. These babies should be started on prostaglandin infusion to

maintain ductal patency and transferred to specialised centres for Norwood procedures.

## NEONATAL JAUNDICE

Jaundice is common in the neonatal period. If jaundice is severe it may lead to bilirubin encephalopathy (kernicterus). Mainly basal ganglia and auditory nucleus are affected, but any part of the brain is at risk. If unrecognised and untreated, it may result in death or severe neurodisability (choreoathetoid cerebral palsy and deafness). Therefore, it is important to identify jaundice, assess the severity with serum bilirubin, measurement identify the cause and treat.

Nearly 7 out of 10 normal neonates are jaundiced in first few days of life. There are several physiological reasons why they are jaundiced. They have high red cell mass at birth (due to the relatively hypoxic environment) short red blood cell life span of approximately 80 days and immature liver conjugation system, and the increased enterohepatic circulation due to sterile gut. The jaundice generally appears on second day of life. It is clinically visible when serum bilirubin reaches 85 micromoles per decilitre (5 mg/dl). It increases in severity until day 4–5 and gradually falls and disappears by day 10. This is known as physiological jaundice and does not usually require any treatment. It is important to remember that the physiological jaundice is

diagnosis by exclusion. Therefore, every jaundiced baby should be carefully evaluated to rule out pathological causes.

If the jaundice appears on the first day of life even in preterm babies, it is deemed pathological and severe enough to require intervention. The same applies if it persists beyond the usual period; it needs investigation and treatment.

Early jaundice is generally secondary to haemolysis although it may be secondary to infection, extensive bruising and concealed haemorrhage. Haemolysis may be secondary to antibodies, or defects in the red cells structure or enzymes. Early jaundice, secondary to haemolysis from incompatible blood group like Rh isoimmunisation is a major cause of haemolytic jaundice although the incidence is declining with anti-D prophylaxis in Rh negative mothers. On the other hand, ABO isoimmunisation is increasing in importance. The jaundice secondary to ABO isoimmunisation is not severe enough to require exchange blood transfusion. Other minor blood group isoimmunisation can also produce neonatal jaundice. The red cell defects such as hereditary spherocytosis and glucose-6-phosphate dehydrogenase deficiency, pyruvate kinase deficiency are not common, but important particularly when there is no obvious cause to explain the presence of jaundice or haemolysis.

The decision to treat jaundice is based on the gestational age of the baby and the postnatal age. Babies who are preterm should be treated at a lower serum bilirubin level than a baby born at term. The level of bilirubin needs treatment. Several factors like general well-being of the baby, severity of haemolysis, and presence of sepsis should be taken into consideration in determining the threshold for treatment.

Adequate hydration is important, as dehydration will increase the serum bilirubin level. Phototherapy and exchange transfusion are the mainstay of treatment. Phototherapy is very effective and acts by photoisomerisation and photo-oxidation of the bilirubin into water excretable forms. The light with wavelength of 450–500 nanometre (blue light) is very effective. Effectiveness of phototherapy can be maximised by increasing the intensity of light (double, triple or quadruple phototherapy) or maximum exposure of the body surface. Standard phototherapy units or bilibed or biliblanket administer phototherapy. The eyes are covered to protect them from exposure to light. Side effects include photodermatitis, temperature instability, loose stools and dehydration.

The effectiveness, availability and the ease of administration of phototherapy has reduced the need for exchange transfusion dramatically. In many places, phototherapy is administered at home with appropriate support and supervision.

Intravenous immunoglobulins is also effective in reducing the severity of haemolytic jaundice. It, together with phototherapy, is very effective and has reduced the need for exchange transfusion.

Exchange transfusion is becoming a rare procedure in developed countries as Rh isoimmunisation is on the decline and phototherapy is effective. The aim of exchange transfusions is to remove antibody coated red cells, antibodies in serum, reduce and correct anaemia. Double volume whole blood (or reconstituted red blood cells) is used for exchange transfusion through umbilical blood vessels. It is an invasive procedure and needs careful preparation, and monitoring. A person experienced in this procedure should do it.

The estimated blood volume of a term neonate is 85 ml/kg while that of a preterm neonate is about 100 ml/kg. Aliquots of 10 ml/kg are used per cycle, with the whole procedure lasting between 45 minutes and 90 minutes. Monitoring of vital signs with intermittent assessment of blood glucose, calcium and haemoglobin is recommended.

In order to ensure no loss of circulating volume, the pre- and post-procedure central venous pressure should be taken.

Rh isoimmunisation is generally recognised early in pregnancy and is monitored by ultrasound scans, cerebral arterial blood flow velocity and sometimes cordocentesis. If the haemolysis is significant, intrauterine transfusion through the umbilical cord is advocated. This procedure is usually carried out in a highly specialised centre. Rh negative blood is used for this procedure. Most babies may require phototherapy at birth and sometimes immunoglobulins but rarely exchange transfusion. They may continue to have on going haemolysis and may need red blood cell transfusion for several months. Blood for these transfusions must be CMV negative and be irradiated to prevent graft versus host reaction.

#### Case Study

A baby girl (twin1) was born at 28 weeks of gestation by emergency caesarean section for poor biophysical profile. She, the recipient of twin-to-twin transfusion, had *in utero* exchange transfusion and amnioreduction for ascites. Post-delivery, she had respiratory distress syndrome (RDS), anaemia, jaundice and Grade II intraventricular haemorrhage (IVH) bilaterally. She developed *Staphylococcus aureus* septicaemia (vancomycin sensitive) at 2 weeks of age and was treated with a 14-day course of intravenous antibiotics (vancomycin and cefotaxime); cerebrospinal fluid (CSF) examination was normal. She developed *S. aureus* thrombophlebitis with abscess formation in the right upper limb during the course of her septicaemia and this was drained. By day 14 blood cultures were negative, the abscess had healed and baby was clinically well. She was discharged home at the corrected gestational age of 33 weeks with an outpatient follow-up appointment.

Two weeks after discharge she was readmitted with episodes of vomiting and apnoea. Cranial ultrasound scan was normal; sepsis was excluded and a presumptive diagnosis of gastro-oesophageal reflux was considered although oesophageal pH study was normal. The vomiting gradually settled over next 3 weeks without any anti-reflux medications and she was discharged home.



In the neonatal follow-up clinic at 41 weeks of corrected gestational age, her head circumference was noted to be above the 50th centile (previously it was growing between 10th and 50th centile). Clinically the baby was well and the cranial ultrasound scan appeared normal. Subsequent review after 2 weeks showed a rapid increase in the head circumference (on 90th centile) with sutural separation and a few dilated scalp veins. The cranial ultrasound scan at this time showed multiple low echogenic areas and cranial CT scan established the diagnosis of multiple brain abscesses with surrounding oedema and a dilated left lateral ventricle.

Aspirate from the frontal lobe abscess grew *S. aureus* on culture. Echocardiogram, abdominal ultrasound, neutrophil functions and immunoglobulins (including IgG subclasses) were normal. The brain CT scan prior to discharge still showed fluid filled areas but a subsequent cranial brain CT scan was reported to be normal with complete resolution of the abscesses.

This case illustrates how the complications of neonatal sepsis can develop insidiously and present in unusual way and also, the importance of growth monitoring.

## INTRAUTERINE GROWTH RESTRICTION OR RETARDATION

In this condition, baby is not able to achieve the expected growth potential. This should not be confused with the term “small for gestational age” (SGA), which means baby’s weight is below 10th centile for that gestational age irrespective of the cause. Although these terminologies are used interchangeably, they should be used with caution.

A baby with intrauterine growth restriction or retardation (IUGR) may be preterm, term or postterm baby. If the baby’s growth is affected very early in pregnancy, the head size, length and weight area all are affected—symmetrical IUGR. If the growth is affected toward the later part of pregnancy, head growth is spared but weight is affected asymmetrical IUGR. The IUGR may be due to maternal or foetal causes. Maternal smoking, alcohol and substance misuse, poor nutritional status, multiple pregnancies, maternal ill health like pregnancy—induced hypertension, chronic renal failure, poorly controlled diabetes, placental failure to name a few causes of IUGR.

Intrauterine infections with the TORCHES complex like cytomegalovirus, rubella, toxoplasmosis, congenital syphilis, herpes and chromosomal anomalies are some of the foetal causes of IUGR.

These babies are at risk of increased mortality and morbidity. Hypoglycaemia, poor temperature control, polycythaemia, meconium aspiration, poor feeding and jaundice are common and need close monitoring. NEC and RDS are also more common in preterm babies who are growth retarded than babies who are appropriately grown.

The IUGR secondary to placental insufficiency may be of variable severity varying from normal placental blood flow, intermittently or completely absent end-diastolic flow to reversed end-diastolic flow.

Clinical examination may show a baby who is scrawny with reduced subcutaneous fat and clinical features hepatosplenomegaly, purpura and cataract may indicate intrauterine infection, while contractures could result from reduced liquor volume.

Investigation and management of these babies is challenging. Careful analysis of the maternal health and clinical examination of the baby helps to streamline the investigations that are required to aid diagnosis. These babies need supportive care to maintain their temperature, blood glucose levels. Associated complications like polycythaemia, jaundice should be managed appropriately. Some of these babies particularly those with severe IUGR and reversed end-diastolic flow or intrauterine infections are at increased risk of adverse neurological outcome.

Prevention of IUGR is important. Promoting the maternal health by avoidance of smoking, alcohol consumption, good nutrition, good control of maternal illnesses like diabetes, hypertension helps to prevent or reduce the extent of IUGR. Although most of these babies are delivered normally, some need to be delivered by elective caesarean section to prevent adverse outcome like intrauterine death, birth asphyxia or meconium aspiration syndrome.

## Low, Very Low and Extremely Low Birth Weight Infants

Any baby with birth weight of less than 2.5 kg is termed as low birth weight (LBW). If the weight is less than 1.5 kg, it is referred to as very LBW and if below 1kg, the term extremely LBW is used. These babies are at increased risk of mortality and morbidity than babies with greater birth weights. The lower the birth weight, the higher the risks of morbidity. Babies with birth weight below 2.5 kg can be managed with measures like keeping them warm and early feeding and maintaining their blood glucose levels. However, very small babies may require extensive support including ventilation and parenteral nutrition. These infants should be cared for in centres with adequate facilities and clinical expertise, including dedicated neonatal medical and nursing staff. Doctors have to remember that many of these babies are born preterm, which again increases the morbidity and mortality based on the immaturity associated with their gestation.

## PRETERM

These babies may be born preterm, this increases their risk of morbidity based on the immaturity of gestation. Any baby

born at before 37 completed weeks of gestation is referred to as a preterm infant. The threshold of viability is variable from country to country based on the facilities and consensus amongst the experts. In the United Kingdom, it is 24 weeks onwards. The more premature the baby, the higher is the likelihood of adverse outcome for morbidity and mortality. Babies born below 32 weeks of gestation are at increased risk of RDS (surfactant deficiency), NEC, and retinopathy of prematurity (ROP) and IVH. They are also susceptible to the risk of infection and long-term developmental problems. These babies should be managed in neonatal units with adequate facilities and well-trained staff. A preterm baby could be small for gestational age, SGA with birth weight (< 10th centile), appropriate for gestational age (AGA) (between 10th and 90th centile) or large for gestational age (LGA) (> 90th centile). Administration of antenatal steroids for preterm deliveries below 34 weeks of gestation has reduced the incidence and severity of RDS and other complications like IVH.

### Postnatal Assessment of Maturity

Although gestation is based on first day of last menstrual period or on the early antenatal ultrasound scans, there are occasions when this is not available. In those circumstances, assessment can be performed using various scoring systems like Dubowitz and Bell's. These assessments are based on physical characteristics like skin thickness, presence of oedema, lanugo, etc. and neurological parameters like tone, range of movements around joints, etc. To get a reasonably accurate gestational assessment, it should be done during first few days of life. It is important to remember that these assessments would not be accurate if the baby is unwell and that the accuracy lies within 2 weeks of the gestational age.

### Immediate Management of Preterm Infant

When compared to term infants, babies with a lower gestation, have a higher mortality and morbidity. Advances in medical technology have improved the survival rate for these babies who may survive with disabilities and other complications.

In countries with good neonatal care, increasing numbers of babies born at or below 24 weeks of gestation are surviving. The best management is to prevent or delay the preterm delivery whenever possible. If the gestation is less than 34 weeks and delivery is imminent, administration of antenatal steroids at least 24 hours before delivery will greatly reduce the severity of significant problems like RDS, IVH and hypotension. Preterm delivery can be delayed by the use of tocolytics like atosiban (oxytocin receptor antagonist), nifedipine (calcium channel receptor antagonist), indomethacin (prostaglandin synthetase inhibitor) or terbutaline (beta receptor antagonist). A delay of up to 48 hours to delivery is sometimes achieved

by this measure. If the preterm delivery is anticipated, the senior paediatrician should speak to the parents and counsel them regarding the survival and morbidity.

At the time of delivery particularly for very preterm babies, experienced clinical staff experienced in resuscitation and stabilisation should be in attendance. Delivering the baby straight into the plastic bag will reduce heat loss and prevents hypothermia. This has also been shown to ensure a normal admission temperature. If the baby shows signs of significant respiratory distress, elective intubation and prophylactic surfactant is of proven benefit. If the baby is born at less than 28 weeks of gestation, and is vigorous, early nasal CPAP is an option to elective intubation and surfactant administration. If the baby requires respiratory support, excessive positive pressure and tidal volumes should be avoided to prevent volutrauma and barotrauma. It is important to remember that most of these babies need support and stabilisation rather than resuscitation.

The increasing use of early nasal CPAP at resuscitation and thereafter, has resulted in fewer babies intubated and receiving endotracheal surfactant.

### Clinical Features

The clinical features of preterm baby depend on their gestational age not only in terms of weight but also in their appearance. Babies who are born near term (33–36 weeks of gestation) may not appear very different from term babies. They are now recognised to have other morbidities and outcomes, which are different from the term or more preterm babies. Preterm babies have less subcutaneous fat, are often oedematous and may have extensive lanugo a larger head and large body surface area.

*Management:* The main thrust of management is to maintain their body temperature, achieve adequate nutrition and provide support for various systems. If the baby is born at 35–36 weeks and is appropriately grown, baby may stay with the mother in the postnatal ward with support from the midwives. Some of them may need heated cot. If the baby is born at less than 35 weeks of gestation, he or she should be managed in the neonatal unit.

*Maintenance of body temperature:* Aim to maintain the baby's body temperature within normal range of 36–37°C with minimal oxygen consumption—the thermoneutral environment. Incubator care is generally needed for more premature babies. Gestational age and presence of other clinical conditions should be taken into consideration. Some preterm babies particularly those born between 33 and 35 weeks may be able to maintain their temperature in a cot, others may need heated cot. Importance of suitable clothing,

hat, mittens and blankets cannot be overemphasised in this group of babies. The incubator temperature should be maintained according to the gestational age of the infant. In general, the lower the gestation, the higher is the incubator temperature. Transepidermal water loss also contributes towards excessive heat loss from the baby's body. Therefore, high humidity should be maintained, if the baby is very premature till the baby's skin is mature. Dehydration is known to result in electrolyte derangement, poor growth and temperature problems like dehydration fever.

### Nutrition and the Preterm Infant

Nutrition is extremely important to prevent both short-term morbidities and adverse long-term outcomes. It is almost impossible to replicate intrauterine nutrition postnatally in preterm babies. There are two determinants—ability of baby to suck and swallow feeds and second is the ability to tolerate the feeds. The more preterm the baby is the greater are these problems. More mature and bigger babies may be started on nasogastric or suck feeds based on their maturity.

Preterm babies with birth weight of less than 1,500 grams are usually started on total parenteral nutrition (TPN) along with lipids during the first few days of life. The regimen is to start these babies of sodium free TPN day 1 at 90 ml/kg and increase by 15 ml every 24 hours until volume of 180 ml/kg is achieved. The standard TPN replaces sodium free TPN after 48 hours. The protein intake should be maximised to about 2.5 gm/kg/day—3.0 gm/kg/day. Start 20% lipid infusion (combination of intralipid® 20% and vitlipid® infant) on day 2 to 3 at 0.5 g/kg per day and increase it by 0.5 g/kg per day to a maximum of 3 g/kg per day while maintaining serum triglycerides within normal limits (serum triglycerides < 1.5 mmol/L, rate increased from 1.5 to 2.0 mmol/L, rate maintained > 2.0 mmol/L, infusion stopped).

Normally feeding is started 24–48 hours after birth at a rate of 15 ml/kg per day and maintained for 24 hours administered as hourly boluses. It may then be increased with reduction in parenteral fluids by 15 ml/kg every 12 hours as tolerated until full enteral feeds were achieved. It is important to monitor electrolytes on daily basis so that electrolytes in TPN are adjusted accordingly.

Expressed breast milk from the mother is the preferred milk. It is important to encourage and give information regarding breast milk to the mothers so that supply is maintained by adequate frequent expressing. If breast milk is not available or inadequate, formula feeds are started. There is a great variation in the practice, some units use hydrolysed formulae, others use term formula or preterm formula to start. In places where donor breast milk is available, it is preferred over formula feeds as it is better tolerated and still has anti-infective properties in spite of freezing and pasteurisation. In babies taking a long-time to

establish adequate enteral nutrition, optimise protein content up to 3 g/kg per day in TPN to achieve adequate nutrition. The neonatal pharmacist and dietician play an important role in the care of these babies.

Our practice is to, necrotising enterocolitis is a life-threatening complication in this group of babies. We aspirate gastric contents every 6 hours. Aspirates measuring less than or equal to 50% of the total feed volume in the previous 6 hours are returned and feeding continued. If the aspirates are more than 50%, feeding is stopped, baby is reviewed and if clinical examination is normal, feeds are restarted at lower rate and increased rapidly to achieve the previous rate and then increased as done previously. Once the baby is on full enteral feeds, feeding interval is increased initially to 2 hours, then 3 hours and finally to 4 hours before baby is ready to be discharged.

### Immaturity of the Organ Function

The skin in preterm infants is thin and fragile. The excessive transepidermal loss of water has already been discussed. Immaturity of kidneys is manifested by the baby's inability to either dilute or concentrate beyond certain point as well as to reabsorb the electrolytes. Therefore, monitoring the urinary output and serum electrolytes in preterm babies is important. Preterm babies have limited reserves of glycogen, fat and gluconeogenesis, and are at high-risk of hypoglycaemia during first few days of life. In very preterm babies, insulin production is limited; this coupled with insulin resistance of the tissues may result in hyperglycaemia. Hyperglycaemia may produce osmotic diuresis, dehydration and electrolyte imbalance. Feed intolerance, manifesting as increased gastric aspirates, bile stained aspirates and abdominal distension is another major problem. Though rare, when hyperglycaemia persists with the need for insulin therapy to achieve normoglycaemia, the diagnosis of transient neonatal diabetes mellitus should be considered.

### Respiratory Disorders

#### *Apnoea*

Prolonged respiratory pauses (more than 20 seconds) in preterm infants may be associated with cyanosis and bradycardia. Although these may be related to immature respiratory centre particularly in babies born below 34 weeks of gestation (apnoea of prematurity), they may be a feature of underlying illness. Therefore, the baby should be evaluated to rule out sepsis, hypoglycaemia and respiratory illness (viral, aspiration, bacterial infections). Management includes treating the underlying condition, while caffeine citrate is useful for apnoea of prematurity. If the episodes are frequent the baby is at risk of significant hypoxia and may be managed with CPAP or ventilation.

### *Respiratory Distress Syndrome*

This was previously called as hyaline membrane disease, which is a pathological diagnosis. This condition is due to surfactant deficiency. Surfactant reduces the surface tension at the alveolar surface and prevents their collapse at the end of expiration. Babies of lower gestation have a higher risk of and severity of RDS. The clinical symptoms start soon after the birth and worsen gradually during first 6 hours of age. Signs and symptoms include increased work of breathing (intercostal and subcostal recession), grunting (exhalation against partially closed glottis to maintain functional residual volume) and cyanosis with increased oxygen requirement. The chest X-ray is characteristic with air bronchogram, generalised atelectasis and reticulogranular opacification. In the pre-surfactant era, many of these babies died and those who survived usually got better after 3 days, following a significant diuresis. The availability of surfactant, CPAP, and better ventilatory strategies and widespread use of antenatal steroids has dramatically altered the clinical course of this illness. Most babies respond immediately to surfactant with decreased oxygen requirement and reduced work of breathing. Prophylactic surfactant has led to even extremely LBW babies been extubated within first 2 days of life. Surfactant is administered under aseptic precautions through the endotracheal tube with necessary precautions to make sure that it is distributed equally to both lungs (endotracheal tube should be in correct position, the baby should be in supine position and head is in midline). Initially, oxygen requirements may be increased but soon there is dramatic response as lung compliance improves. It is important to monitor very closely and adjust the ventilator settings and oxygen requirements to avoid hyperoxia, volutrauma, barotraumas and hypocarbia (reduced carbon dioxide), because hypocarbia produces cerebral vasoconstriction and volutrauma increases the risk of chronic lung disease of the newborn. The surfactant of bovine and porcine origin is available and is used based on the local guidelines and experience.

### *Persistent Patent Ductus Arteriosus*

The ductus arteriosus serves an important function in the foetal life by diverting the blood from pulmonary trunk into aorta. It closes soon after birth as the pulmonary pressure falls. However, in preterm babies, it may not close due to immaturity of the ductal tissue. As the systemic pressure is higher than pulmonary pressure, the blood flows from aorta into pulmonary trunk and to lungs. This has important implications. Firstly, it increases the preload on the heart and secondly, it causes pulmonary congestion. The baby develops tachycardia, wide pulse pressure from diastolic run off and metabolic acidosis. Babies may develop renal

dysfunction, reduced blood supply to gut (increased risk of necrotising enterocolitis) and arterial steal from the cerebral circulation. The clinical manifestations depend on the extent of shunting across the ductus and associated morbidities particularly RDS. Diagnosis is based on clinical findings and echocardiography to assess the size and the effect of duct on the heart. One of the common measurement used is left atrium to aortic ratio. Decision to treat the PDA should be taken based on careful clinical evaluation. If the baby is clinically well and PDA is not significant, there is no need to treat and it may close spontaneously. If it is significant, it may be managed conservatively (fluid restriction, CPAP) or by medical management (administration of prostaglandin inhibitors like indomethacin and ibuprofen) and ductal ligation (rarely needed). Prostaglandin inhibitors may have renal and gastrointestinal side effects and may also affect platelet function. Therefore, decision to treat should be taken by a senior clinician and parents should be informed.

### *Intraventricular Haemorrhage*

Intraventricular or periventricular bleeding is a major problem in preterm babies born at less than 32 weeks of gestation. The more preterm the baby is, the higher the risk of IVH. Administration of antenatal steroids to the mother will reduce the risk. The parents should be counselled regarding this risk if preterm delivery is anticipated. It is important to perform an early cranial ultrasound scan as soon as the baby is stabilised. Cranial ultrasound scan is usually performed on days 1, 3, 7 and 28 of life. Risk of bleeding is highest during first 72 hours of life, slightly reduced from day 4 to 7. The risk of intraventricular bleed is low after day 7 of life. Although it is common practice to correct any clotting abnormality in preterm babies, there is lack of evidence on any reduction in the incidence of IVH. There is also no consensus regarding normal values of clotting times in neonates; therefore, practices vary. The onset of a bleed may be heralded by sudden drop in haemoglobin, increased ventilatory requirement, hemodynamic instability and blood glucose instability. Bleeding may extend during first few days of life.

Intracranial haemorrhage is Graded I-IV. When the bleed is confined to the germinal matrix, it is Grade I, if it extends into the ventricular cavity, it is Grade II, if the intraventricular bleed is associated with ventricular dilatation, this is Grade III and if the bleeding is in the brain parenchyma, it is regarded as Grade IV. Grades III and IV are associated with increased morbidity. If the Grade IV bleeding is bilateral and extensive, it carries high-risk of major neurodisability. Parents should be kept fully informed of the presence and progression of IVH. Another complication is post-haemorrhagic hydrocephalus for which management remains a challenge.

### *Retinopathy of Prematurity*

Previously called as retrolental fibroplasia (pathological), the preferred name is ROP. Retinopathy of prematurity, a condition affecting the developing retinal vascular system of preterm babies, is one of the few largely preventable causes of childhood visual impairment. The risk of ROP is higher at lower gestation. The World Health Organization's vision 2020 programme aims to have a world in which no one is needlessly blind and for those with unavoidable visual loss to achieve their full potential. The risk can be reduced by preventing hyperoxia, hypoxia with careful attention to inspired oxygen concentration and other factors which shift the oxygen dissociation curve to the right, e.g. transfusion of adult red blood cells. The retinopathy may not be obvious in the initial stages and it appears as the retina develops. Therefore, it is important to screen the very LBW babies (< 32 weeks at birth) for ROP at regular interval. An experienced ophthalmologist should carry out the examination. The use of Retcam is beneficial in especially in the units without a dedicated ophthalmologist. This will minimise the risk of visual loss by the proven benefits of laser therapy. Intraocular injection of bevacizumab (Avastin) is showing good promise as being an equally effective treatment for severe ROP.

### *Jaundice*

Preterm babies are particularly vulnerable. Just as in term babies, physiological jaundice does not appear in the first 24 hours of life but the threshold for intervention is low. The decision to treat will depend on the gestational age and day of life as well as other factors like presence of bruising, sepsis. The lower the gestation, the lower is the serum bilirubin level at which phototherapy is started. Again based on the levels, particularly, if there is haemolysis, exchange transfusion may be needed—although rare. Availability and effectiveness of anti-D immunoglobulins in haemolytic disease of the newborn has reduced the need for exchange transfusion significantly.

The physiological jaundice in preterm babies reaches its peak between day 7 and 10 (in term babies, it is usually on day 4 and 5) and takes longer to clear. If the jaundice is persisting beyond day 21, the baby should be evaluated and investigated to rule out other pathological conditions like biliary atresia, hypothyroidism, intrauterine infections, galactosaemia, etc. Presence of normal coloured stools and urine are reassuring as these babies are unlikely to have obstructive jaundice. Breast milk jaundice is commonly believed to be due to a factor, possibly 3-alpha, 20-beta-pregnanediol. This diagnosis is considered after excluding other conditions.

## CHROMOSOMAL ABNORMALITIES

The most common chromosomal abnormality seen in neonatal period is trisomy 21 (Down syndrome) and occasionally trisomy 18 (Edward syndrome) and trisomy 13 (Patau syndrome) are also seen. In developed countries and in many developing countries, antenatal screening usually confirms the diagnosis in antenatal period itself and parents have the option of either continuing the pregnancy or to go for termination. Although incidence of trisomies increases as the maternal age advances, the number of babies born to these mothers with Down syndrome is less now due to antenatal screening. Therefore, authors see more babies with Down syndrome being born to younger mothers. The underlying chromosomal abnormality may be due to nondisjunction, Robertsonian balanced translocation in parents, or mosaicism.

The children with Down syndrome have many clinical features like mongoloid slant of eyes, brushfield spots, bilateral epicanthic folds, small ear lobes, flat occiput, short neck, clinodactyly, short stubby hands, hypotonia, increased gap between big toe and second toe (sandal sign). Many of these features may be familial and seen in perfectly healthy children. It is the combination of these findings which is diagnostic. It is imperative that unguarded comments are not made by nursing or inexperienced staff based on their first impression. It is a very sensitive period and insensitive handling of the situation will cause long lasting damage to patient doctor relationship. Baby should be assessed by experienced clinician before speaking to parents. It is important to remember that the diagnosis may be delayed in preterm babies as dysmorphic features may not be very obvious, or baby is unwell and needs intensive care and all efforts are directed towards managing acute problems. Once clinical diagnosis is suspected, it should be conformed by chromosomal analysis. Rapid test using PCR technique is available in many places and diagnosis can be confirmed within 24 hours. Once the diagnosis is confirmed parents should be counselled regarding the underlying genetic abnormality and the risk of recurrence in future pregnancies particularly if it is due to balanced translocation in parents. It may be appropriate to refer them to clinical geneticist.

Babies with Down syndrome are more likely to have feeding difficulties, polycythaemia and significant jaundice. Incidence of congenital heart diseases particularly atrioventricular septal defect and duodenal atresia is high. All the babies born with Down syndrome should be seen by a senior paediatrician to counsel the parents and also to assess the child for any underlying congenital abnormalities. These babies need careful follow-up to look for any visual defects like refractive errors, hearing problems and developmental delay. They will need assessment of thyroid status at 1 year of age. Parents will appreciate if information regarding local Down syndrome support group and websites are provided.

Other trisomies like Edward and Patau syndrome are not common but create challenges in the management. Although most of these children are likely to die soon, there are some who survive for extended period of time. This poses particular problem if the baby also has correctable congenital heart problem—whether to correct or not? Parents need extra support to cope with this uncertainty.

Many babies are born with unexplained subtle dysmorphic features and various clinical problems like failure to gain weight, feeding difficulties, etc. and conditions like congenital myotonic dystrophy, spinal muscular dystrophy should be considered. It is important to obtain a detailed family history and a review by a senior paediatrician is very useful. If the diagnosis is uncertain, doctors should explain the findings, uncertainty of diagnosis and need for genetic investigations to look for deletion/duplication syndromes following parental consent and geneticist's opinion. It is important that the adequate blood sample is sent in correct specimen bottles to the laboratory, and it is worthwhile checking with the laboratory before sending the sample.

Off late, with the advances in molecular genetics, many other conditions which were previously missed are picked up. Following case history demonstrates one such case.

### Case Study

#### Case 1

Baby was born at 31 weeks gestation by emergency caesarean section for foetal distress with birth weight (2,350 g) and head circumference (32 cm), greater than 97th centile. The antenatal period was uneventful. Baby had sloping forehead, flat nasal bridge and a prominent tongue and larger left half of the body. There was intermittent hypoglycaemia in the first 3–4 days which resolved subsequently. Based on the findings of macroglossia with hemihypertrophy, Beckwith-Wiedemann syndrome (BWS) was suspected. Genetic tests confirmed the diagnosis of BWS as a result of uniparental (paternal) disomy at chromosome 11p15. This type is known to be associated with higher risk of developing tumours. Baby was discharged home with arrangements for 3 monthly abdominal ultrasound scans and regular monitoring of the alpha-fetoprotein (AFP) (for tumour surveillance). Baby developed hepatoblastoma and needed chemotherapy and tumour resection for the hepatoblastoma. Baby also had speech problems related to the large tongue. This is the classical variety.

#### Case 2

Baby was born at term by spontaneous vaginal delivery to a primigravida with uncomplicated pregnancy and was growth restricted with birth weight of 2,800 g, 10th centile, and head circumference of 32 cm, less than 10th centile and had flat nasal bridge and prominent forehead and a left sided large asymmetric tongue. Baby had normal female karyotype (46 XX) and samples were sent from baby and both parents to rule

out BWS in view of asymmetrical large tongue. Apart from slow feeding probably secondary to large tongue, her course was otherwise uncomplicated, her blood sugars were stable, cranial and abdominal ultrasound scans were normal. Her AFP was initially high during first week and subsequently normalised. She was discharged home at 30 days of life after establishing full suck feeds.

Analysis of the blood sample revealed loss of methylation at the KvDMR1 (differentially methylated region), but no hypermethylation at the H19 DMR. This was consistent with a diagnosis of BWS. After consultation with the geneticist, it was explained to the parents that the baby was not at increased risk of tumours and AFP screening was not absolutely necessary. Parents opted to have only the 3 monthly ultrasound of abdomen. These two cases demonstrate the differing clinical features of same condition and how the less classical variety could have been missed if not suspected and also advances in molecular genetics.

### Beckwith-Wiedemann Syndrome

Beckwith-Wiedemann syndrome was described independently in the 1960s by Dr Wiedemann and Dr Beckwith. Children with BWS have some of these five major features: (1) macroglossia, (2) macrosomia, (3) hypoglycaemia at birth, (4) abdominal wall defect (exomphalos) and (5) ear pits or creases. Associated findings include hemihypertrophy, increased incidence of renal anomalies, hypercalciuria, and predisposition to tumours, especially abdominal tumours (Wilm's tumour, adrenal carcinoma and hepatoblastoma). Other abnormalities seen are cleft palate, refractory hyperinsulinaemia, mental retardation and polydactyly. The syndrome has a molecular aetiology related to genetic and epigenetic mutations on 11p15. Majority are sporadic; however, 15% are inherited and 1% occurs due to chromosomal abnormalities. There has been a suggestion linking the increased number of BWS with the increase in assisted reproductive treatment (ART). The described population frequency ranges from 1 in 13,700 to 1 in 15,000 births (Fig. 3.2).

## HAEMATOLOGY

### Clotting Abnormalities

Coagulation abnormalities are common among preterm babies and could be reflective of underlying disease processes but are fought with pitfalls. The interpretation of coagulation profile in newborn infants needs consideration of gestational age, postnatal age and the state of well-being of the neonate. Many studies have shown that adult reference ranges for coagulation screening tests, especially prothrombin time (PT) and activated partial thromboplastin time (APTT), cannot



**Fig. 3.2:** Beckwith-Wiedemann syndrome

be applied to newborns and young infants. The normal haematological ranges for term and preterm babies issued by the British Society of Transfusion and Tissue Transplantation is not gestation age dependant as there can be marked variation in the clotting profile between the preterm infants of different gestations. Results of the coagulation assay are also technique dependant and differ between laboratories.

In one of our surveys of the British Association of Perinatal medicine numbers more than 75% of the respondents did not consider routine coagulation screen in preterm babies and only 39% had written policy on the management of clotting abnormalities. It is interesting to note that almost 30% did not agree with the specified normal range for preterm APTT. Therefore, it is essential that decision to treat or not to treat is taken after careful consideration of the clinical condition of the baby. Authors normally use fresh frozen plasma if the clotting remains abnormal after administration of vitamin K.

### Polycythaemia

Polycythaemia is relatively common condition in babies with IUGR and also in infant of diabetic mother. Sometimes, it may be secondary to placental transfusion like in delayed cord clamping. High haematocrit (Hct) increases the viscosity with attendant complications like jaundice, hypoglycaemia,

thrombocytopenia and rarely renal vein thrombosis. There is no consensus in the management of this condition. However, if the baby is symptomatic with hypoglycaemia, thrombocytopenia and central Hct is more than 70%, partial exchange transfusion with 5% salt poor albumin or normal saline to reduce the Hct is practiced by many clinicians.

### Thrombocytopenia

Thrombocytopenia in neonatal period may be secondary to sepsis or secondary to isoimmune thrombocytopenia from platelet group incompatibility between the baby and mother. Occasionally, thrombocytopenia may be secondary to maternal immune thrombocytopenia like idiopathic thrombocytopenic purpura.

Alloimmune thrombocytopenia is not common but is important because it may cause intracranial haemorrhage in the foetus. It may be necessary to deliver these babies by caesarean section to avoid trauma during delivery. If the baby has severe thrombocytopenia, intravenous immunoglobulins and steroids have been used in addition to platelet transfusion. It is important to inform the laboratory early so that they can arrange for compatible platelets.

The threshold for transfusion of platelets in sepsis is variable. Generally, platelet count of less than 50,000 per cubic mm is considered as an indication. Sometimes, it would not improve the platelet count. In such situations, if the baby is stable and does not bleed excessively after venepuncture or heel pricks, threshold can be set higher.

### Neutropenia

This is a relatively common finding particularly in preterm infants. In preterm infants, neutropenia usually resolves toward the end of 2nd week of life. There is no need for any intervention. However, management of neutropenia in septic babies is controversial. Many neonatologists use granulocyte colony stimulating factor to improve neutrophil count. However, there is no definite evidence that it improves the outcome.

### INBORN ERRORS OF METABOLISM

Although these conditions are rare, they are very important as early detection and management will affect their long-term outcome. Neonatal spot screening in many countries will detect phenylketonuria (PKU) which is amenable for management by dietary interventions. Although the list of these disorders is exhaustive, the clinical manifestations are nonspecific and may suggest sepsis. Therefore, inborn errors of metabolism should be considered in all unwell babies.

Generally, baby is well at birth and becomes unwell soon after the feeding is started. Clinical features may suggest sepsis. Hypoglycaemia and metabolic acidosis are commonly

found. If there is any family history of unexplained neonatal death, diagnosis should be considered strongly. If the sepsis is unlikely in view of absence of risk factors, laboratory markers of infection, obtain blood samples for metabolic screen, lactate and ammonia, urine specimen for organic acids and amino acids and stop the feeds. Start the baby on dextrose infusion to correct hypoglycaemia. It may be necessary to correct the acidosis and any electrolyte abnormality, treat any seizures. It is prudent to start antibiotics until infection is ruled out and diagnosis is established. Liaison with metabolic team will be very helpful. Once the diagnosis is established, parents should be informed about the diagnosis, prognosis and referred to clinical geneticist who will be able to advise them on risk of recurrence in future pregnancies.

## The Infant of a Diabetic Mother (IDM)

### Diabetes in Pregnancy

- *Insulin-dependent diabetes*: Maternal metabolism exists from time of pregnancy, through to organogenesis and beyond.
- *Gestational diabetes*: Maternal metabolism is altered mostly in last half of gestation (sparing critical period of organogenesis).

This topic is important due to the associated morbidities below:

1. Unexplained death
2. Hypoglycaemia
3. Respiratory distress syndrome
4. Congenital anomalies
5. Others (polycythaemia, hypocalcaemia, hypomagnesaemia, hyper-viscosity syndrome)
6. Preterm delivery
7. Abnormalities of growth.

### Unexplained Death

- Peri-natal mortality even with carefully managed DM is approaching that of general population. And gestational diabetes, even with euglycaemia has been associated with stillbirth rate of 7.7/1,000 (compared with 4.8/1,000).

The risk of congenital anomalies is high in IDM; this is believed to be associated with the following factors:

- Somatomedin inhibitors, genetic susceptibility, some unknown maternal factors and free oxygen radicals
- Others are altered metabolic fuels:
  - Maternal hyperglycaemia
  - Maternal hyperketonaemia
  - Maternal hypoglycaemia.

### Incidence:

- Insulin-dependent diabetes occurs in 0.5% of all pregnancies

- In addition, 3–5% of women exhibit biochemical abnormalities during pregnancy consistent with gestational diabetes.

### Abnormalities of Growth

This is believed to occur in 40% of these pregnancies, in the form of LGA or SGA.

*Pederson's hypothesis for macrosomia*: Result of maternal hyperglycaemia → Foetal hyperglycaemia → Foetal hyperinsulinaemia → Growth of insulin-sensitive tissues → Fat deposition and organomegaly → Complications.

### Macrosomia/Large for gestational age:

- The macrosomic baby is usually greater than 4,000 grams while the LGA baby is greater than 90th percentile weight for gestational age.
- IDM accounts for less than 10% of LGA, but up to 60% of IDM can be LGA, however.

*Small for gestational age*: Mothers with renal or cardiac diseases may have SGA or premature infants. These babies are prone to poor foetal outcome, foetal distress or foetal death.

### Metabolic Disorders

- *Hypoglycaemia (<2.6 mmol/L)*: It is present in 20–40% of IDMs, most commonly in LGA. Usually within 0.5–2 hours after delivery.
- *Foetal hyperinsulinaemia*: Suddenly supply of glucose is disrupted.
- Inability to mount adequate catecholamine and glucagon response.

### Clinical presentation:

- Presents within 30 minutes to 2 hours of birth
  - Infant may have a wide range of symptoms and signs ranging from jitteriness, tachypnoea, cyanosis, apnoea and seizures
- If SGA is caused by decreased glycogen stores. It appears 6–12 hours after delivery.

### Management:

- Check serum glucose after birth
- Determine severity with values and symptoms
- Oral feeds, high calorie formula, intravenous 10% dextrose for maintenance
- Consider central line if hypertonic solution is used
- Normal glucose infusion rate is 6–8 mg/kg per minute
- Use glucagon may be necessary in extreme situations.

*Hypocalcaemia (<2.0)*: Incidence is up to 50%.

Due to decreased function of the parathyroid glands. Lowest levels at 24–72 hours of age. There is possible role for the effect of calcitonin.



Hypomagnesaemia (<7): Related to parathyroid hormone, as well as to maternal hypomagnesaemia (abnormal kidney function).

*Clinical presentation:*

- Similar to hypoglycaemia
- Presentation usually at 24–72 hours.

*Management*

Hypocalcaemia: 10% calcium gluconate 0.5 ml/kg per dose (0.11 mmol/kg) slow IV with cardiac monitoring, then maintenance IV 0.5 mmol/kg per day over 24 hours as infusion. It tends to resolve within 3–4 days of treatment.

Hypomagnesaemia: 0.4 mmol/kg  $Mg^{2+}$  (100 mg/kg) magnesium sulphate over 10 minutes 6–12 hourly as necessary, IV or IM with cardiac monitoring and blood levels q/12 hourly.

*Perinatal asphyxia:*

- It occurs in up to 25% of infants of diabetic mothers
- This believed to be due to restricted intrauterine area and increased oxygen demand via hyperinsulinaemia and inability of placenta to compensate.

*Respiratory Disorders*

- The incidence of respiratory distress is 3%. Transient tachypnoea of the newborn, surfactant deficiency, cardiac disease and sepsis can affect the IDM in this way.

*Respiratory distress syndrome occurs in 15% of IDM:*

- Qualitative or quantitative deficiency of surfactant
- Five-fold increase in infants of diabetic mothers
- Pathophysiology of surfactant deficiency:
  - Hyperinsulinism affects lung maturation by antagonising the action of cortisol.
  - An L/S ratio of 3:1 can be used to determine surfactant maturity.

*Clinical presentation*

- Physical examination may show cyanosis, expiratory grunting, tachypnoea, chest wall retractions, oedema.

*Management*

- Chest X-ray (CXR)
- Blood gases, culture, full blood count (FBC) and C-reactive protein
- Cardiac evaluation if warranted
- Oxygen therapy as needed
- Keep NPO until aetiology determined or improved.

*Cardiac Disorders*

Hypertrophic cardiomyopathy may occur in up to 30% of IDMs.

- Due to increased fat and glycogen deposition in the myocardium.
- May lead to congestive heart failure.

The common types of cardiac disorders are transposition of the great arteries with or without VSD, and coarctation with or without VSD or patent ductus arteriosus. Others are ASD and cardiomegaly.

*Haematological Disorders*

- Hyperbilirubinaemia is usually secondary to prematurity, immature liver enzymes and polycythaemia
- The management involves the measurement of serum bilirubin, blood group, Coombs
- The babies should have adequate hydration, with the mainstay of treatment as phototherapy. Any underlying identified aetiology should be treated for example sepsis.

*Polycythaemia:*

- Definition: Central “spun” Hct is greater than 65%
- This condition occurs in 20–40% IDMs
- It occurs due to increased levels of erythropoietin in IDM resulting in increased red blood cell production
- In itself can cause hypoglycaemia.

*Clinical presentation:*

- IDM will have system specific symptoms and signs
- Renal venous thrombosis, which is rare, may be caused by, caused by hyperviscosity
- Disseminated intravascular coagulopathy may present with haematuria and abdominal mass.

*Management:*

- Adequate hydration
- FBC, coagulation screen, blood glucose
- Serial Hct for at least 3 days
- Although partial exchange transfusion when the Hct is greater than 70% or at lower level if symptomatic is practiced in some centres, there is no convincing evidence of the benefit of long-term neurologic advantage.

*Shoulder dystocia:*

- Shoulder dystocia: Baby’s shoulder is stuck behind mother’s pubic symphysis preventing delivery
- Erb’s palsy: Stretch injury of C5–C6 resulting from downward force on the shoulder and lateral flexion of the neck.

*Epidemiology:*

- Shoulder dystocia occurs in 0.2–2% of non-diabetics, 60% of whom are LGA while 3–9% of Erb’s palsy occurs in IDM, 85% of which are LGA
- The infants of a diabetic mother have increased fat deposition on shoulder and trunk.

*Clinical presentation of Erb's palsy:*

- Paralysis of deltoid, infraspinatus and flexor muscles of forearm
- Forearm extended and internally rotated the function in grasp maintained, but there is absent Moro reflex.

*Management:*

- May X-ray arm bones to look for fractures
- Serial clinical examination is required on follow-up. It usually heals without intervention, but early physiotherapy referral is recommended
- If there is no improvement by 6 months referral to a joint Erb's palsy team for assessment is advised.

*Congenital Anomalies*

- Ten times commoner in the IDM as compared to the general population
- Major anomalies occur in 5–8% of these pregnancies
- Most malformations nonspecific and nonchromosomal, on average occurs in 6.4% of IDMs
- Anomalies account for up to 50% of perinatal deaths involving the cardiovascular system, gastrointestinal system and the bones.

*Skeletal and Central Nervous System*

- Caudal regression sequence
- Skeletal defects: Hemivertebrae
- Neural tube defects excluding anencephaly
- Anencephaly with or without herniation of neural elements
- Microcephaly.

*Gastrointestinal System*

- Duodenal atresia
- Anorectal atresia
- Small left colon syndrome.

*Renal*

- Hydronephrosis
- Renal agenesis
- Ureteral duplication.

*Others*

- Single umbilical artery
- Thromboembolic phenomenon (cerebral infarction, renal cortical and digital gangrene).

*Initial assessment:*

- Prenatal: Ultrasound for size and anomalies, biophysical profile, maternal HbA<sub>1c</sub>

- Delivery room: Physical examination for congenital anomalies, size for dates, respiratory distress.

*Postnatal evaluation (age hours):*

- Plasma glucose: 0.5, 1, 1.5, 2, 4, 8, 12, 24, 36 and 48
- Calcium: 6, 24 and 48
- Magnesium: Check if calcium low
- Hb/Hct : 4, 24
- Platelet count: 24
- Bilirubin: Based on clinical jaundice
- True blood glucose, FBC, CRP, microscopy/culture
- Radiologic studies: If there is evidence of cardiac, respiratory or skeletal problems
- Echocardiography should be performed if hypertrophic cardiomyopathy or cardiac malformation is suspected.

*Long-Term Complications*

- Obesity—up to 50%
- Risk of subsequent type I diabetes by age 20 years at least 7 times that of non-diabetic parents
- Adverse neurodevelopment in 4% of cases, e.g. poor psychomotor development, hyperactivity (may relate to maternal ketosis, hypoxia, hypoglycaemia, seizures)
- Iron deficiency (lower 9-month ferritin levels).

**MULTIPLE GESTATION**

Although multiple pregnancies can occur spontaneously, there is an increase in the incidence of multiple gestation partly due to treatment for infertility. Multiple gestation pregnancies are associated with an increase in morbidity. These babies are more likely to be born preterm more so, with triplets and quadruplets. Twinning is either monozygotic or dizygotic. If the zygote divides early, it results in two separate chorion and amniotic sacs (dichorionic and diamniotic); division a little bit later results in monochorionic and diamniotic twins (single chorion but two amniotic sacs). If the separation occurs much later, it results in monochorionic and monoamniotic twins (single amniotic sac).

There is also increased risk of twin-to-twin transfusion with increased morbidity and mortality for both the twins. Although twin-to-twin transfusion has been treated with—amnioreduction, laser ablation of placental vessels is increasing available in specialised centres. Apart from obstetric difficulties and increased caesarean section rate, there is also evidence of increased risk of neurodisability (cerebral palsy) especially in monozygotic twins.

Some other problems are growth retardation and anaemia in donor twin, polycythaemia in the recipient twin, with the attending risk of hyperviscosity syndrome, circulatory overload with cardiac dysfunction.

## MATERNAL SUBSTANCE AND ALCOHOL ABUSE

This is increasingly becoming a significant problem in developed countries. Consumption of significant amounts of alcohol during pregnancy results in foetal alcohol syndrome spectrum disorders. Some recognised features are triangular face, long philtrum and thin upper lip but these findings can be very subtle and difficult to recognise. The non-availability of specific test for diagnosis has further complicated this issue. The true incidence is, therefore, not known. These children may have learning difficulties and behavioural problems. It is important that alcohol consumption before conception and pregnancy is discouraged by increasing the awareness amongst youngsters and also by providing support to quit drinking. This is an important public health message especially when it not clear that foetal alcohol spectrum disorder is dose dependent.

Babies born to mothers who are misusing opiates and other drugs may develop neonatal withdrawal symptoms. The term neonatal abstinence syndrome (NAS) is used for opiate withdrawal and neonatal drug withdrawal for other drugs. Cocaine use is associated with increased risk of cerebral infarctions and NEC, in view of its vasoconstrictive effects.

These neonates may present with irritability, tremulousness, excessive crying, seizures, loose stools and perianal excoriation.

It is important to rule out other conditions before labelling it as NAS, as these babies may have other pathologies just like any other ill baby. It is important, therefore, to exclude infection, electrolyte abnormalities, low blood sugar, low calcium and magnesium. In the presence of seizures, intracranial haemorrhage and meningitis should be ruled out.

Upon diagnosis, symptoms should be managed as far as possible by nonpharmacological measures like swaddling, minimal stimulation and regular feeds. Several scoring methods like Lipsitz are available to guide the initiation of pharmacological treatment and the monitoring of response. Replacement with oral morphine sulphate is the authors' first choice when nonpharmacological measures are unsuccessful. The dose is increased gradually to achieve symptom control. At maximum dose of oral morphine, if symptoms persist, oral phenobarbitone is added. Chloral hydrate may be used for symptom control.

It is important to remember that lack of response may be due to the use of multiple drugs during pregnancy. Some babies gain weight very poorly and many require an increased amount of milk or high calorie milk. Feeding incoordination is also a common problem.

These social circumstances and lifestyle are not uncommonly challenging and chaotic, and this calls for

adequate support for the family unit prior to and following discharge from hospital.

These babies are at increased risk of cot death. It is important to deal with these parents in a sensitive way to avoid them feeling guilty, as some of these mothers would have made efforts during pregnancy to discontinue or reduce medications during pregnancy, or have been in a supervised drug program, and they need support and understanding. The authors recommend that the baby be vaccinated for hepatitis B if mother is an intravenous drug user. In addition, it is our policy to offer hepatitis B vaccination to all the babies born to mothers who are drug misusers irrespective of whether their use intravenous or not.

## NEONATAL SEPSIS

Infection in the neonatal period carries high mortality and morbidity and the neonate's clinical course can deteriorate quite rapidly. Therefore, strong index of suspicion and prompt action is required because the symptoms and signs are nonspecific.

Early onset sepsis (before 48 hours of age) is commonly due to organisms from maternal environment like GBS and *Escherichia coli*. Predisposing factors include like prematurity, prolonged rupture of membrane for greater than 18 hours, intrapartum maternal pyrexia, chorioamnionitis, positive maternal high vaginal swab for GBS. Whereas the signs and symptoms of sepsis are nonspecific, it is not uncommon for the respiratory features to be indistinguishable from RDS. They may require correction of clotting abnormalities, ventilatory/respiratory support and inotropes for hypotension. The use of benzylpenicillin and gentamicin is recommended to cover for sepsis. Similarly, if there is any suspicion of listeriosis, amoxicillin or ampicillin should be added.

The duration of antibiotics is dependent of the blood culture results, inflammatory markers and clinical improvement.

Gestation is associated with the degree of immaturity of the immune system due to inadequate passively transmitted antibodies, which takes place in the last trimester of pregnancy.

In a baby with suspected of sepsis, blood should be sent for blood culture, FBC and C-reactive protein. Lumbar puncture and suprapubic aspiration of urine for culture and sensitivity are also recommended. Other acute phase reactants, like ceruloplasmin, fibrinogen and transferring procalcitonin, are not routinely measured.

Group B streptococcal infection carries with it a high mortality and morbidity. Approximately 25–30% women carry GBS in their genital tract. Although a significant number of babies are colonised with these organisms at birth, most would have passively transferred antibodies from their

mothers and remain asymptomatic and require no treatment. However, small percentage of them will develop invasive disease. In some countries like the United States of America, pregnant women are screened for GBS during the later part of pregnancy and are offered intra-partum prophylaxis if they are carriers. This is not the practice in the United Kingdom. Where risk factors are used to determine the use of intra-partum antibiotic prophylaxis. Benzylpenicillin is effective, and clindamycin is used if mother is allergic to penicillin. If a mother has received inadequate or no prophylaxis, the baby should be started on antibiotics after obtaining blood for culture, inflammatory markers and FBC. Onset of invasive GBS infection after 48 hours is called late onset infection and carries with it a high incidence of meningitis.

Prevention of GBS infection even with screening programmes does not eliminate infection because women may carry GBS intermittently. There are attempts to develop a vaccine, which will effectively prevent both early onset and late onset GBS infection in neonates if given to mothers during pregnancy or to teenage years.

Among the organisms responsible late onset sepsis is coagulase negative staphylococci. In intensive care settings, intravenous vancomycin and gentamicin is used as a second line choice of antibiotics.

For most infections a 5–7 day course is used, but, in meningitis, the duration of antibiotics should be for at least 14 days for gram-positive organisms and 21 days for gram-negative organisms.

The evidence of benefit for intravenous immunoglobulin for the treatment of sepsis is thin and therefore not supported. Similarly use of granulocyte colony stimulating factor for neutropenia in the presence of sepsis has not been shown to be effective.

The practice of asepsis to prevent infection cannot be overemphasised. Simple techniques like handwashing or using alcohol gel between patients or strict asepsis during invasive procedures is highly effective and should be universally practiced. The presence of invasive lines particularly central lines increases the risk and they should be removed at the earliest. Similarly establishment of full enteral feeds will reduce the needs for intravenous lines and hence the incidence of infection.

## NEONATAL PROCEDURES

Apart from capillary blood sampling from heel prick, intravenous cannulation, other important skills include lumbar puncture, umbilical venous line, umbilical arterial line and radial line insertion. It is important for the paediatrician to be competent in all the above procedures although insertion of umbilical arterial line or radial line is not essential. Many neonatologists are also trained to carry out cranial ultrasound scans and neonatal echocardiography.

## VACCINATION AND WEANING

The local immunisation schedule should be followed. There is no need to delay the vaccination in view of prematurity. In babies born below 28 weeks of gestation and those who have chronic lung disease, first dose of routine vaccination should be done in the hospital as there is increased risk of apnoea and increased oxygen requirement. They should be observed for 48–72 hours post-vaccination before discharge.

Weaning should generally start around 6 months of age when the baby shows interest in foods and takes things to mouth. Exclusive breastfeeding or formula feeding up to 6 months of age is adequate to meet the nutritional requirements of the baby. There is no need to delay the weaning in view of prematurity.

## NUTRITION

The appropriately grown term infants should be demand breastfeeding or formula fed if the mother decides not to breastfeed. However, preterm babies and babies who are SGA pose a particular challenge. Babies who are LBW and full-term are managed with demand feeding once initial difficulties with blood sugar and feeding are overcome.

However, babies are increasingly being discharged at lower weight (1.8 kg and above) and gestation (34–35 weeks) posing unique challenges. Adequate nutrition during early infancy is essential for overall well-being of the baby and can have a major impact on long-term development. The LBW is associated with a number of immediate adverse consequences. Preterm and term infants born SGA carry a high-risk for continued growth deficits, neurodevelopmental abnormalities and behavioural problems.

It has been assumed that improving nutritional status by vigorous feeding in infancy is associated with lower morbidity and mortality. The window for catch-up growth in growth-retarded babies appears to be narrow. If the catch-up growth does not take place in early life, the chances that it will occur later are limited. In human infants, this critical period may approximate to the first year with respect to development of head circumference and the first 3 years with respect to final height. It is natural that we want the babies to gain weight rapidly to catch-up. However, there is insufficient evidence to suggest that protein and energy enriched formula fed to preterm babies had any effect on the development at 18 months of age, with one study showing girls fed on enriched formula having lower developmental quotient at 9 months of age.

Following Barker's observation in 1980s that LBW is a risk factor for cardiovascular disease and diabetes in adulthood, many studies have strengthened the notion that size at birth is a determinant of later health.

There is increasing concern that the postnatal weight gain is also a risk factor for cardiovascular disease and diabetes in adulthood. Emerging evidence suggests that either LBW or rapid postnatal weight gain or the combination of both may predispose to adverse long-term effects like the metabolic syndrome. Therefore, there may be a price to pay at later stage in the form of higher likelihood of some chronic adult diseases if the weight gain is either poor or excessive.

### What is Catch-up Growth and What is Accelerated Growth?

Catch-up growth follows prior growth retardation, such as IUGR or postnatal nutritional insult. It involves moving up centiles and usually involves linear (bone) and muscle growth as well as accumulation of fat. This is desirable. Rapid weight gain or accelerated growth may occur at any time as a result of excessive energy intake and represents the acquisition of surplus adipose tissue with no acceleration of linear growth. This is undesirable.

In contrast to body weight, reduced bone mineralisation generally improves rapidly during the first months of life. Between 6 and 12 months of age, bone mineralisation of infants born preterm reaches values, adjusted for anthropometric parameters, similar to healthy term infants and appears appropriate for skeletal and body size achieved. With all the controversies and evidence available, doctors should aim for appropriate growth not excessive weight gain.

There are different types of formulae milk for infant feeding, such as term formula, preterm formula and nutrient-enriched formula. Doctors can also fortify breast milk. The superiority, complexity and richness of human milk, with nutrients that meet specific requirements for development and non-nutritional factors modulate neonatal adaptation, provide protection and immune defence is finely tuned to regulate infant growth.

Most formulae are based on bovine milk; their amino acid and fatty acid profiles reflect the needs of calves. Moreover they lack other non-nutritive factors found in human milk. Such deficiencies are associated with poorer neuron-cognitive development and intelligence quotients and enhanced risk for respiratory and enteric infections. Formula milk intake is determined by the mother or caregiver rather than by infant demand as in breastfed baby. So breast milk is preferred.

There is no definite evidence that post-discharge preterm growth is higher in infants who receive nutrient-enriched formula milk compared to standard term formula. One study found that the infants fed with standard term milk consumed more milk than those fed with high energy formula.

For every baby, doctors should plot the birth weight, length and head circumference against gestational age and

determine whether the infant is AGA (birth weight between 10th centile and 90th centile), SGA (birth weight < 10th centile) or LGA (birth weight > 90th centile). This will help us to decide nutritional management of the baby.

Our feeding policy encourages breast milk. Most of our preterm babies are on either expressed breast milk alone, expressed breast milk with fortifier or preterm formula (150–200 ml/kg per day) or combination of both. Breast milk fortifier may not be necessary if the baby is gaining weight satisfactorily and should not be started routinely. The milk of the mother delivering a preterm baby often has relatively high protein content in the first 2 weeks of life. Fortification is best avoided until after 2 weeks after delivery. Growth chart should be updated every week and should be reviewed before changing any milk. Once the baby's weight is 1,800–2,000 grams and is gaining weight (between 10th centile and 90th centile), and then if the baby is on breast milk with fortifier, stop the fortifier and continue breast milk or if on preterm formula, change the milk to term formula.

At the time of discharge, most of the babies in the neonatal unit who are on term formula or breast milk with a weight of 1,800 grams or more are discharged on the same milk unless there are any concerns. If not, categorise the babies into one of the four groups and take the action based as indicated below.

1. Infants with birth weight and a body weight at discharge appropriate for postconceptional age (appropriate growth).

*Discharge feed:* Breast milk or term formula

2. Infants born AGA but with discharge weight below the reference growth chart (postnatal growth restriction).

*Discharge feed:* Following assessment and discussion breast milk with fortifier or preterm formula or nutrient-enriched formula

3. Infants born SGA with a discharge weight still below the reference growth chart (IUGR).

*Discharge feed:* Following assessment and discussion breast milk with fortifier or preterm formula or nutrient-enriched formula

4. Infants born SGA with discharge weight appropriate for postconceptional age (early catch-up growth).

*Discharge feed:* Breast milk or term formula

If the baby is discharged on nutrient-enriched formula, it should be changed to regular formula at corrected post-conceptional age of 40 weeks or 52 weeks. If the baby is on nutrient-enriched formula, multivitamins or iron supplementation should be stopped.

If the baby is on any special formula, child's growth should be regularly monitored and once weight gain is satisfactory, the milk should be changed to regular formula and weight gain is monitored.

## DISCHARGE PLANNING

It is important that parents feel confident enough to look after the baby after stressful period. These babies would have been looked after by nursing and medical staff and help has been readily available if there were any concerns. Suddenly, that support is taken away. It is, therefore, important to prepare the parents for anticipated discharge. During the baby's stay in the unit, parents should be involved in day to day care of the baby as far as possible. They should be educated about the baby's clinical condition, any special requirements, if the baby is going home on any special equipments like apnoea monitor, suction pump, home oxygen or tube feeds and they should be confident in using them, also what to look for, what to do in an emergency and whom to contact if anything goes wrong. It is a good idea for parents to room in with the baby in the neonatal unit for few days to gain confidence before taking any baby who had significant problems and or stayed in the neonatal unit for long period of time. It is important to inform the other health professionals who will look after the baby once discharged about the baby's clinical condition and anticipated date of discharge.

Before discharging any baby, they should be suck feeding well, gaining weight, maintaining temperature in cot and not have any apnoea or desaturations. Although a weight of 2 kilograms is used in many neonatal units, it is not an absolute requirement. Maturity rather than weight is more important.

## WITHHOLDING AND WITHDRAWAL OF TREATMENT

Even though doctors have made great progress in neonatal care, some babies may be born in very poor condition. They may have serious congenital anomalies or become seriously unwell that continuing or initiating the treatment may not be in the best interest of the baby. In such circumstances, the baby should be carefully assessed by the senior clinician and discussed with the other members of the team about the best course of action. It should be explained to parents the clinical condition, prognosis and possible course of action and option of withdrawal or withholding of the care. Parents should be given all the information and time to decide. It is imperative that clinician's opinion is not imposed on the parents.

If the decision is made to withdraw or withhold the treatment, palliative care to provide comfort to the baby should be initiated. This includes nutrition, pain relief and warmth. Parents should be made aware that baby may not die immediately and may survive for extended period of time.

The situation should be handled sensitively by senior medical and nursing staff. Parents should be given privacy to spend time with their baby. Any requirement for religious ceremony such as baptism should be discussed with parents

and arranged as required. It is desirable to discuss the autopsy or organ donation with parents at this stage.

Once the baby has died, photographs, foot and hand prints, lock of hair may be obtained for parents to keep for memory and arrangements made for burial or cremation. Clear documentation of discussion with parents, diagnosis and decision should be clearly documented in the case notes.

## NEWBORN HEALTH IN DEVELOPING COUNTRIES

### INTRODUCTION

Each year an estimated 4 million babies die before they reach the age of one month, and another 4 million more are stillborn, dying between 22 weeks of pregnancy and birth. About 98% of these newborn deaths take place in developing countries, and for the most part these newborn deaths occur at home in the absence of any skilled healthcare (Fig. 3.3). Thus, developing a better understanding of home care practices, leading to effective behaviour change communication strategies to promote healthy behaviours while discouraging harmful practices, is a priority.

WHO estimates that 40–60% of neonatal deaths are potentially preventable and it may be possible to save over 2 million newborn infants through basic low-cost interventions. More epidemiological research is needed to make available more accurate data on risk factors and causes of neonatal morbidity and mortality, and improved and validated neonatal verbal autopsy instruments are needed in order to collect accurate data.

Most newborn deaths are largely due to infections (36%), birth asphyxia and injuries (23%) and consequences of prematurity and congenital anomalies (34%). Infections may account for approximately half of newborn deaths at the

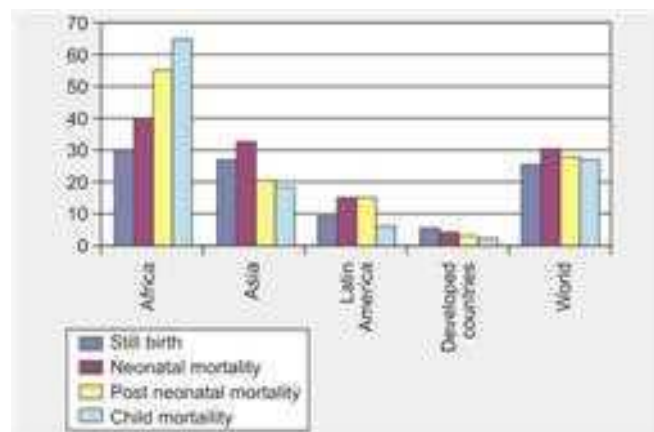


Fig. 3.3: Child mortality rates and rates of stillbirths per 1,000 births (Source: World Health Organisation)

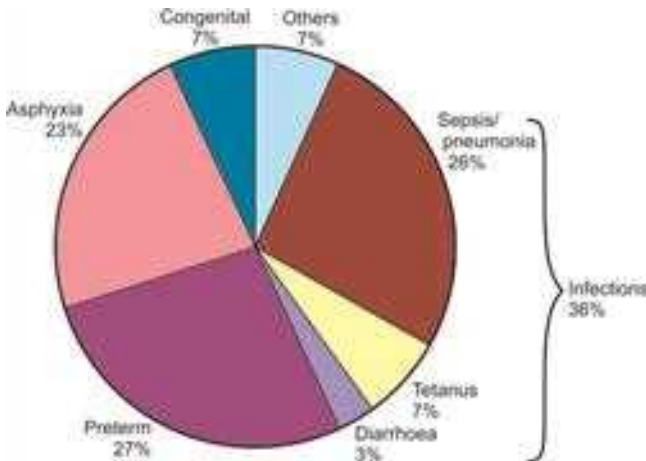


Fig. 3.4: Major problems affecting neonates in the developing world

community level. The LBW is an overriding factor in the majority of the deaths (Fig. 3.4).

### BIRTH ASPHYXIA

Failure to breathe at delivery is probably the mechanism responsible for asphyxia secondary to some acute crisis such as an antepartum haemorrhage or cord prolapse. Affects mainly cortical and subcortical grey matter of the brain (Table 3.1).

#### Epidemiology

Intrapartum asphyxia is a single most important cause of perinatal and neonatal morbidity and mortality. An estimated 4–9 million cases of birth asphyxia occur each year in the developing world, accounting for 24–61% of all perinatal mortality and an estimated 1.2 million newborns die annually of birth asphyxia. Sarnat and Sarnat introduced a grading system to describe the neurological dysfunction which was modified by Levene et al (Table 3.2).

#### Diagnosis

The diagnosis of birth asphyxia is based on clinical as well as biochemical findings (Table 3.3).

1. Tricuspid regurgitation murmur may be audible early in the course of disease.
2. Arterial blood gas shows acidosis, high pCO<sub>2</sub> and low pO<sub>2</sub>.
3. Lactic acid provides a sensitive measure of end organ perfusion.

Table 3.1: Aetiology and risk factors

- *Antenatal:* Maternal diabetes, pre-eclampsia
- *Intrapartum:* Breech presentation, cord compression, placental abruption, maternal shock, infection
- *Postnatal:* Congenital heart disease, respiratory failure

Table 3.2: Grading system to describe the neurological dysfunction

Grade I (Mild)	Grade II (Moderate)	Grade III (Severe)
Irritability	Lethargy	Comatose severe
Mild hypotonia	Relative hypertonia	Hypotonia
Poor suck	Tube feeds	Failure to maintain spontaneous respiration
No seizures	Seizures	Prolong seizures

Table 3.3: Diagnostic criteria

- Profound metabolic acidosis (pH < 7.0) and base deficit > 12 on arterial sample
- Apgar score of 0–3 for longer than 5 minutes
- Neurologic manifestation, e.g. seizures, coma or hypotonia
- Multisystem organ dysfunction, e.g. cardiovascular, gastrointestinal, pulmonary or renal systems

4. EEG may show seizures and background slowing.
5. Drop in Hct may indicate intracranial bleed.

#### Prevention

At delivery, most neonates can be successfully resuscitated by simple techniques such as tactile stimulation and, in some cases, clearing of upper airway secretions using a gauze-covered finger or simple mucus extractor. The need for bag-mask ventilation is exceptional and can be accomplished using room air. Routine caesarean section for preterm babies presenting by the breech is much more controversial. There is yet no randomised control trial for the benefit and hazards of such intervention to prevent birth asphyxia.

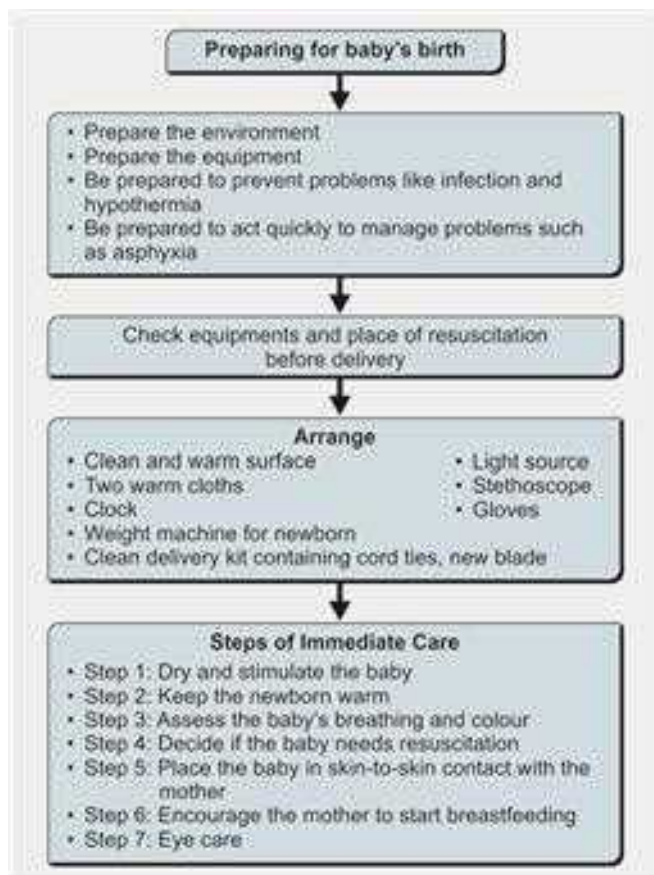
#### Neonatal Resuscitation

Extensive efforts to train physicians in neonatal resuscitation are needed, for example, using WHO and American Academy of Pediatrics-American Heart Association Neonatal Resuscitation Programme materials, are underway in many developing countries, and are showing encouraging results in influencing behaviour. Few studies, however, especially community-based studies have evaluated appropriate methods to train health workers and family members at the community level to recognise birth asphyxia and provide simple interventions and support (Flow charts 3.1 and 3.2).

#### Goals of Management

Unsupervised, unskilled delayed and complicated deliveries that characterise obstetrics in developing countries, and the high frequency of LBW babies contributes to a high prevalence of birth asphyxia and birth trauma. The aim should be to provide these equipment and training of doctors and nurses for essential neonatal care at primary health centre.

**Flow chart 3.1:** Immediate or routine care of newborn at birth



### Medical Management

- Maintain adequate oxygenation and ventilation. Avoid hyperventilation. Keep  $O_2$  saturation greater than 90% and  $pCO_2$  between 35 and 50 mm Hg
- Inotropes for maintenance of adequate blood pressure
- Fluid restriction to treat SIADH
- Delay gastric feeding until adequate gut perfusion is ensured
- Treat seizures if necessary with phenobarbital
- Treat hypoglycaemia.

### Prognosis

Prognosis can be predicted by recovery of motor function and sucking ability. There are case reports in the past established that babies who had suffered a severe and clear insult some time before labour could be neurologically abnormal in the neonatal period and end up with cerebral palsy. Early onset of seizures and use of multiple medications predict worse prognosis. Severely affected infants often require gastrostomy tube for feeding and tracheotomy with home ventilation (Table 3.4).

## NEONATAL INFECTIONS

### Epidemiology

Infections account for 30–50% of all neonatal deaths in developing countries, with pneumonia, tetanus, sepsis and diarrhoea the most common causes. Knowledge of the aetiology of infectious diseases in neonates in developing countries is based almost entirely on studies of hospitalised infants or on retrospective, verbal autopsy-based surveys in the community, neither of which may accurately reflect the true burden of disease in the community.

The reported incidence of neonatal sepsis varies from 7.1 to 38 per 1,000 live births in Asia, from 6.5 to 23 per 1,000 live births in Africa and from 3.5 to 8.9 per 1,000 live births in South America and Caribbean. The WHO's recommended clinical criteria for diagnosing sepsis and meningitis in neonates are given in Table 3.5. The main organisms causing sepsis in developing countries are shown in Figure 3.5.

### Prevention

In developing countries, 90% of mothers deliver babies at home without skilled health professional present. Simple low-cost interventions, notably tetanus toxoid vaccination, exclusive breastfeeding, counselling for birth preparedness, breastfeeding promotion through peer counsellors and women's groups, have been shown to reduce newborn morbidity and mortality. Alcohol-based antiseptics for hand hygiene are an appealing innovation due to their efficacy in reducing hand contamination and their ease of use.

The most effective strategies for preventing and treating neonatal infections in developing countries is to devise simple, inexpensive management strategies for reducing the morbidity and mortality of neonatal infections, risk factors, historical information, and clinical signs and symptoms predictive of serious neonatal infections (pneumonia, sepsis and meningitis) must be identified for use in first line healthcare facilities and at home by trained caregivers and healthcare workers.

### The Role of Breastfeeding

A wide variety of benefits of breastfeeding have been well-documented, including reduced risk of hypothermia, hypoglycaemia, NEC, omphalitis, acute respiratory infections, diarrhoea, septicaemia and mortality, particularly in the late neonatal period. Although breastfeeding is common, immediate and exclusive breastfeeding, despite its benefits, is not normal practice in many developing countries, particularly for LBW newborns. Breastfeeding also provides a variety of immune and nonimmune components that accelerate intestinal maturation, resistance to and recovery from infection.



Flow chart 3.2: Neonatal resuscitation

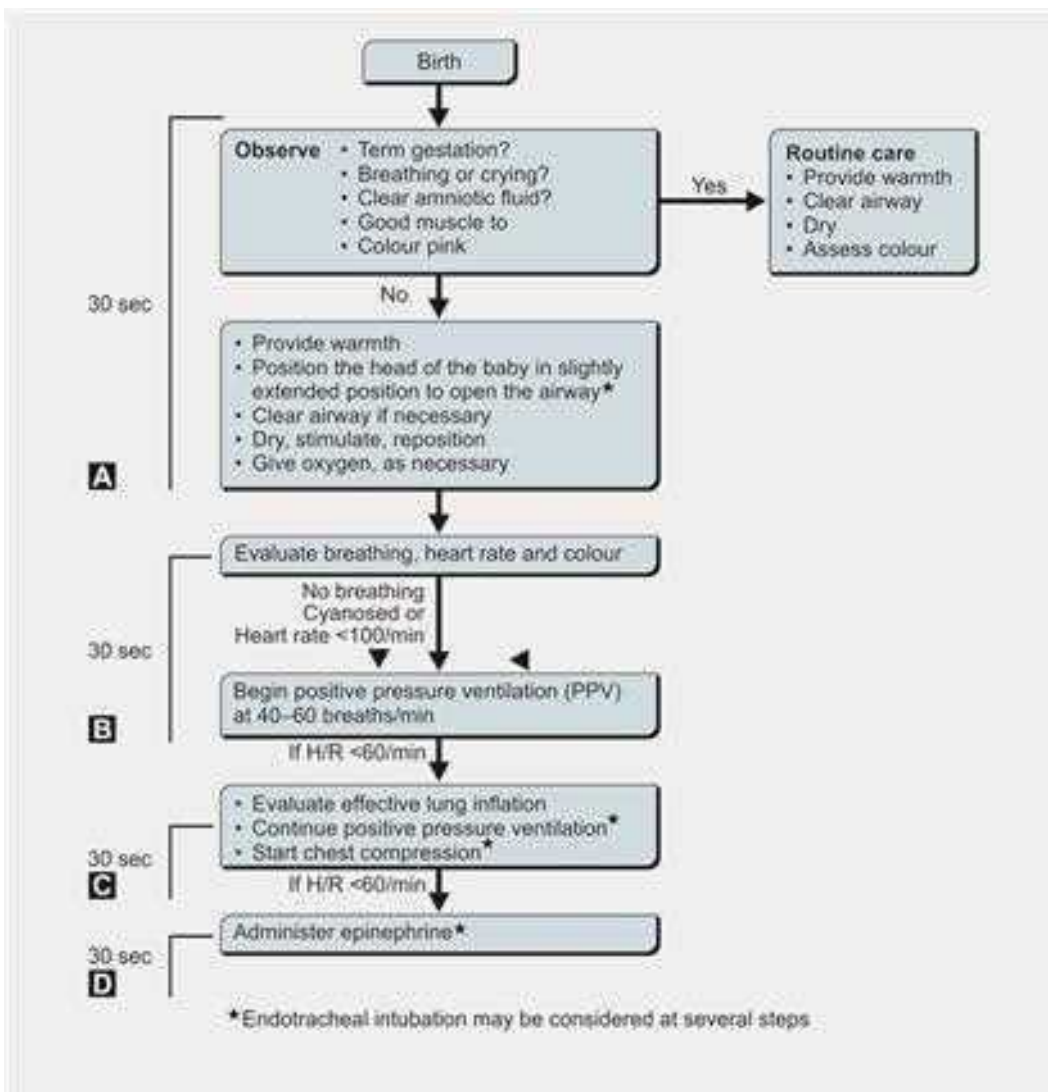


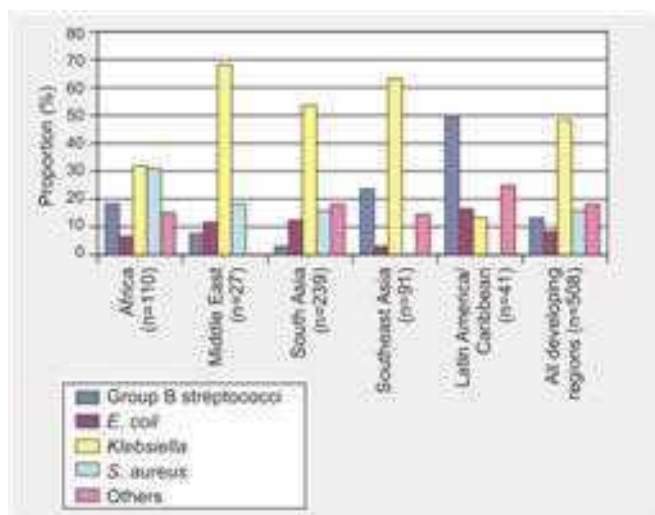
Table 3.4: Outcome associated with very low Apgar score (0–3)

Time (min)	Number of live-born	< 2,501 g			> 2,500 g			
		Death by 1 year (%)	Number known to 7 years	Cerebral palsy (%)	Number of live-born	Death by 1 year (%)	Number known to 7 years	Cerebral palsy (%)
1	428	25.5	257	1.9	1,729	3.1	1,330	0.7
5	163	55.2	56	7.1	286	7.7	217	0.9
10	67	67.2	15	6.7	66	18.2	43	4.7
15	51	84.3	8	0	23	47.8	11	9.1
20	139	95.7	7	0	39	59	14	57.1

**Table 3.5:** World Health Organization's recommended clinical criteria for diagnosing sepsis and meningitis in neonates\*

Sepsis	Meningitis
<b>Symptoms</b>	<b>General signs</b>
Convulsions	Drowsiness
Inability to feed	Reduced feeding
Unconsciousness	Unconsciousness
Lethargy	Lethargy
Fever (more than 37.7°C or feels hot)	High pitched cry
Hypothermia (less than 35.5°C or feels cold)	Apnoea
<b>Signs</b>	<b>Specific signs</b>
Severe chest indrawing	Convulsions
Reduced movements	Bulging fontanelle
Crepitations and cyanosis	

\* The more symptoms, a neonate has the higher the probability of the disease



**Fig. 3.5:** Pathogens involved in early neonatal infection is less than one week in hospitals of developing countries

### Role of Umbilical Cord and Skin Care

Little is known, however, about traditional umbilical cord practices in the community. Application of antiseptics such as chlorhexidine, has been shown to be effective against both gram-positive and gram-negative bacteria and shown in the community studies to reduce rates of cord infection and sepsis in the newborn. In rural Pakistan, application of ghee heated with cow dung to the umbilical stump was associated with neonatal tetanus, but in studies, in which topical antimicrobial agents were applied to promote wound healing, instead of ghee, suggests that promotion of antimicrobial applications as a substitute for ghee might be an effective strategy.

**Table 3.6:** Newborn danger signs of infection

- Breathing problems
- Feeding difficulties/unable to suck
- Cold body temperature/hypothermia
- Fever
- Redness swelling or pus around the cord
- Convulsions/fits
- Jaundice

A randomised controlled trial of topical application of sunflower seed oil to preterm infants in an Egyptian NICU showed that treated infants had substantially improved skin condition and half the risk of late onset infection.

### Diagnosis

The danger signs are shown in Table 3.6.

### Investigations

- Blood cultures (may be negative if antibiotics were administered to the mother)
- Urine cultures
- CSF studies (protein, glucose, cell count and cultures)
- Complete blood count with differential:
  - Immature to total neutrophil ratio greater than 30% should raise suspicion of sepsis
  - A drop in platelet count is often a late sign
- C-reactive protein is a nonspecific marker of infection
- Chest X-ray to distinguish pneumonia from RDS
- Hypoglycaemia
- Metabolic acidosis.

### Medical Treatment

Knowledge of the antimicrobial resistance patterns of common neonatal bacterial pathogens is essential for planning empiric antimicrobial therapy for the treatment of neonatal infections.

Currently, WHO recommends that acutely infected neonates less than 2 months of age be treated in a healthcare facility capable of administering parenteral antibiotics (e.g. benzylpenicillin or ampicillin plus, an aminoglycoside, such as gentamicin). Every attempt should be made to deliver this standard of care. Hospitalisation and parenteral treatment of neonates, however, is not feasible in many communities. Thus alternative treatment strategies are needed, including the feasibility and efficacy of therapy in the home and treatment with oral antibiotics. Guidelines for Integrated Management of Childhood Illness (IMCI) have been widely implemented as the main approach for addressing child health in health systems. Table 3.7 shows the antibiotic treatment of sepsis and meningitis.

**Table 3.7:** Antibiotic treatment of neonatal meningitis and sepsis

Patient group	Likely aetiology	Antimicrobial choice	
		Developed countries	Developing countries
<b>Sepsis</b>			
Immunocompetent children	Developed countries	Ampicillin/Penicillin	Ampicillin/Penicillin
	<i>Streptococcus</i> (Group B)	Plus aminoglycoside	Plus aminoglycoside
	<i>E. coli</i>	Gentamicin	Or
	Developing countries		Co-trimoxazole plus
	<i>Klebsiella</i>		Gentamicin
	<i>Pseudomonas</i> <i>Salmonella</i>		
<b>Meningitis</b>			
Immunocompetent children (age < 3 months)	Developed countries	Ampicillin plus ceftriaxone	Ampicillin plus
	<i>Streptococcus</i> (Group B)	or ceftrizoxime	Gentamicin
	<i>E. coli</i>		
	<i>L. monocytogenes</i>		
	Developing countries		
Immunodeficient	<i>S. pneumoniae</i>		
	<i>E. coli</i>		
	Gram-negative organisms <i>L. monocytogenes</i>	Ampicillin plus Ceftazidime	

Following the demonstration of significant reduction in neonatal mortality with the use of oral cotrimoxazole and injectable gentamicin by community health workers this strategy could be employed in circumstances where referrals are difficult.

## Prognosis

Gram-negative sepsis has a high mortality rate. Associated meningitis may result in long-term developmental abnormalities (e.g. hearing loss).

## TERM IUGR/LBW

Various terms have been used to describe babies whose weight is low for their gestational age including intrauterine growth restriction or retardation, foetal malnutrition, light-for-dates and small-for-dates.

## Regional Epidemiology

Low birth weight babies constitute 16% (20 million) of all live births worldwide. The 29th World Health Assembly (1976) defined LBW infants as those weighing less than 2,500 g at birth. The vast majority takes place in the developing world ranging from 33% in South Asia to 67% in Africa. Much higher frequencies for SGA infants are reported from India

**Table 3.8:** In a normal infant, the brain weighs about three times more than the liver. In asymmetrical IUGR, the brain can weigh five or six times more than the liver

Classification of IUGR	
Symmetrical	Asymmetrical
The baby's head and body are proportionately small. May occur when the foetus experiences a problem during early development.	Baby's brain is abnormally large when compared to the liver. May occur when the experiences a problem during later development

(77–90%). The aetiology of IUGR babies is summarised in Tables 3.8 and 3.10.

Problems in low birth weight babies have been discussed in Table 3.9.

## Prevention and Recurrence

Small case reports suggested low-dose aspirin prophylaxis during pregnancy may reduce the risk of recurrent IUGR in women at high-risk, subsequent large randomised trials have not confirmed significant risk reduction. Antihypertensive therapy of hypertensive women does not improve foetal growth.

In subsequent pregnancies, any potential treatable causes of IUGR, e.g. thrombophilic disorder should be treated promptly.

**Table 3.9:** Problems in low birth weight babies

- Breathing problems
- Hypothermia/Hypoglycaemia
- Feeding problems
- Infections
- Jaundice
- Coagulopathy
- Polycythaemia

### Diagnostic Strategies

Clearly, from what has been said, the assessment of gestational age can be performed by doing complete history and physical examination to look for maternal, placental or foetal disorders associated with impaired foetal growth (e.g. alcohol abuse, inherited or acquired thrombophilia, maternal vascular disease). Additional imaging and laboratory evaluations are also directed toward determining an aetiology.

### Management

The management strategies for growth restricted babies in the developing countries would be their prevention by reducing teenage pregnancies, increasing the birth interval, improving maternal nutrition, treating anaemia and prompt treatment of maternal infections. These measures would promote significant increase in the birth weights and would break the vicious cycle of growth-retarded females who become stunted adults and produce growth-retarded babies.

### Prognosis

The preponderance of intrauterine growth-retarded infants in the developing world related to the observation that such

infants grow into adults with an increased risk of death from ischaemic heart disease. Congenital malformations, perinatal asphyxia and transitional cardiorespiratory disorders contribute to the high mortality rate in term IUGR infants.

Poor developmental outcome has been associated with IUGR that involved poor head growth (symmetric IUGR). Impairments of verbal outcome, visual recognition memory and general neurodevelopmental outcome have been found to be altered at and years. Cognitive disabilities are seen more frequently than motor disabilities.

It is hoped that the recognition of the intrauterine growth restricted babies antenatally and in the neonatal period as a special high-risk infant, and the prompt institution of both therapeutic and prophylactic measures, will result in an improved outlook for this group of growth restricted infants.

## CONGENITAL MALFORMATIONS AND INHERITED DISORDERS

The birth prevalence of congenital anomalies in developing countries is similar to that observed in developed countries. However, the health impact of birth defects is higher due to a lack of adequate services for the care of affected infants, and a higher rate of exposures to infections and malnutrition, although as a proportion of infant deaths, is greater in wealthier countries (Table 3.11).

A number of successful measures for the prevention of congenital anomalies are being taken in a number of developing nations. Primary prevention programmes are based on public education about preconceptional and prenatal risks. Prevention based on reproduction options includes teratogen information services and prenatal screening for foetal anomalies.

**Table 3.10:** Aetiology of intrauterine growth restriction or retardation

#### Maternal risk factors

- Drugs (anticoagulants, anticonvulsants)
- Cardiovascular disease—pre-eclampsia, hypertension, cyanotic heart disease, diabetic vascular lesions
- Chronic kidney disease
- Chronic infection—UTI, malaria, TB, genital infections
- Antiphospholipid syndrome, SLE

#### Foetal risk factors

- Exposure to rubella, cytomegalovirus, herpes simplex, tuberculosis, syphilis, or toxoplasmosis, parvovirus B19
- A chromosome defect: Trisomy 18 (Edward syndrome), trisomy 21 (Down syndrome), trisomy 13 and XO (Turner's syndrome)
- A chronic lack of oxygen during development (hypoxia)
- Placenta or umbilical cord defects

#### Placental factors

- Uteroplacental insufficiency resulting from:
  - Inadequate placentation in the first trimester
  - Lateral insertion of placenta
  - Reduced maternal blood flow to the placental bed
- Fetoplacental insufficiency due to:
  - Vascular anomalies of placenta and cord
  - Small placenta, abruptio placenta, placenta previa, post-term pregnancy

**Table 3.11:** Major birth defects and inherited disorders in the developing world

- Down syndrome
- Thalasaemia
- Sickle cell disease
- G6PD deficiency
- Oculocutaneous albinism
- Cystic fibrosis
- Phenylketonuria
- Neural tube defects and hydrocephalus
- Congenital heart disease
- Cleft lip and plate
- Developmental dysplasia of hip

In addition, programmes for the detection of congenital malformations at birth, followed by early treatment, are contributing to secondary prevention. Prevention of congenital anomalies in the developing world requires:

- Good epidemiological data on the prevalence and types of birth defects and genetic disorders
- Educating health professionals in the goals and methods of preventing birth defects at low cost but with high impact
- Expansion of family planning and improvement of antenatal care combined with educational campaigns to avoid the risks for birth defects.

## PREMATURITY

Preterm birth refers to a birth that occurs before 37 completed weeks (less than 259 days) of gestation. A very preterm birth is generally defined as less than 32 weeks of gestation and late preterm between 34 and 37 weeks gestation. Preterm birth is the second leading cause of infant mortality, after congenital anomalies, and a major determinant of neonatal and infant morbidity.

On the basis of an international disease classification system, 61% of the early neonatal deaths were due to prematurity or LBW in developing countries. It is difficult or meaningless to compare the survival statistics of developed and developing countries when the latter have insufficient facilities and equipment. Poor infection control results in serious infections that rank very high as the cause of neonatal death in such countries. The complications associated with prematurity are shown in Table 3.12.

## RESPIRATORY DISTRESS SYNDROME

Respiratory distress syndrome (RDS) is a common cause of neonatal mortality in many parts of the world. Developed countries spend a vast expenditure on equipment, training and research for babies with RDS. Such expenditure would be inconceivable in developing countries.

**Table 3.12:** Complications associated with prematurity

- Respiratory distress syndrome
- Hypothermia
- Hypoglycaemia
- Haemorrhagic and periventricular white matter brain injury
- Bronchopulmonary dysplasia
- Necrotising enterocolitis
- Apnoea/Anaemia of prematurity

**Table 3.13:** Factors associated with RDS

- Higher male incidence
- Caesarean section without labour
- Second twin
- Maternal diabetes

Reports of RDS in developing countries are seldom an overall incidence from any one country but rather from various hospital studies. For reasons to be discussed this incidence may increase with improvements in perinatal care. Largely, the major determinant of the incidence of RDS is the proportion of deliveries which are preterm. Common pulmonary conditions that need to be differentiated from RDS are transient tachypnoea of newborn, pneumonia, pneumothorax and PPHN. The factors associated with RDS are shown in Table 3.13.

The diagnosis of RDS is made from the combination of clinical and radiological findings. It is rarely occurs over 38 weeks gestation. There is a tachypnoea, grunting, retraction of chest wall in moderate to severe cases. Multiple randomised, controlled clinical trials indicate the benefits of surfactant replacement therapy, including reduction in the severity of RDS.

The overall mortality of the RDS has now been reduced to between 5% and 10%. Up to 50% of babies weighing less than 1.5 kg and who survive RDS will require readmission to a general paediatric ward within first year of life.

## Hypothermia and Hypoglycaemia

Hypothermia and hypoglycaemia may be prevented through simple and inexpensive interventions. Risk factors for hypoglycaemia include birth asphyxia, prematurity and hypothermia. Hypothermia is common in developing countries, affecting more than half of all newborns in many communities, and is associated with an increased risk of mortality. Hypothermia also is associated with increased rates of morbidity, including increased risk of neonatal infections, coagulation defects, acidosis, delayed foetal-to-newborn circulatory adjustment, hyaline membrane disease and IVH.

Hypothermia can be prevented by simple measures such as ensuring a warm environment during delivery,

**Table 3.14:** Effects of hypothermia on babies

- Lethargy
- Poor feeding/weak cry
- Peripheral oedema
- Marked facial oedema (may give false impression of healthy infant)

**Table 3.15:** Classification of IVH (Volpe)

Grade I	Haemorrhage of germinal matrix
Grade II	Intraventricular haemorrhage without ventricular dilatation
Grade III	Intraventricular haemorrhage with ventricular dilatation
Grade IV	Intraventricular haemorrhage with parenchymal involvement

early breastfeeding and skin-to-skin contact with the mother, proper bathing, drying and swaddling, and prompt identification and rewarming of hypothermic neonates. Basic knowledge and practice of thermal control, however, generally are inadequate among healthcare providers and families in developing countries. The effects of hypothermia on babies are shown in Table 3.14.

### Haemorrhagic and Periventricular White Matter Brain Injury [Periventricular Leukomalacia (PVL)]

The germinal matrix is a weakly supported and highly vascularised area that is prone to rupture upon fluctuations in cerebral blood flow. This condition remains the most common cause of death in very LBW neonate ventilated for RDS. Most IVH occurs in the first 72 hours after birth.

The incidence and severity of IVH is inversely proportional to gestational age and rare after 32 weeks post-conceptual age. The development of large IVH is usually associated with subtle clinical deterioration in a ventilated child with increase in ventilatory support, anaemia, fall in blood pressure, acidosis and neurological signs. Cranial ultrasonography is the most frequent imaging modality used to diagnose IVH. The classification of IVH is shown in Table 3.15.

To date, no single intervention has been found to prevent IVH although many approaches have been tried. Best approach would be to minimise the hemodynamic instability during the perinatal period. Uncomplicated IVH has a good prognosis. About 30% of infants with IVH went on to develop post-haemorrhagic ventricular dilatation and have the highest risk of adverse neurodevelopmental outcome. Prognosis for

the white matter brain injury is even more difficult to ascertain as not all brain injuries are haemorrhagic but there is no doubt that PVL is the most powerful predictor of cerebral palsy.

## BIBLIOGRAPHY

1. Adair LS, Popkin BM. Low birth weight reduces the likelihood of breastfeeding among Filipino infants. *J Nutr.* 1996;126:103-12.
2. Bang AT, Bang RA, Baitule S, et al. Burden of morbidities and the unmet need for healthcare in rural neonates—a prospective observational study in Gadchiroli, India. *Indian Pediatr.* 2001;38:952-65.
3. Bennett J, Ma J, Traverso H, et al. Neonatal tetanus associated with topical umbilical ghee: covert role of cow dung. *Int J Epidemiol.* 1999;28:1172-5.
4. Bhutta ZA, Darmstadt GL, Hasan BS, et al. Community-based interventions for improving perinatal and neonatal health outcomes in developing countries: a review of the evidence. *Pediatrics.* 2005;115(2):519-617.
5. Christensson K, Ransjo-Arvidson AB, Kakoma C, et al. Mid-wifery care routines and prevention of heat loss in the newborn: a study in Zambia. *J Trop Pediatr.* 1988;34:208-12.
6. Costello A, Manandhar D. Current state of the health of newborn infants in developing countries. In: Costello A, Manandhar D (Eds). *Improving Newborn Health in Developing Countries.* London: Imperial College Press; 2000. pp. 3-14.
7. Ellis M. Birth asphyxia in developing countries: epidemiology, sequelae and prevention. London: Imperial College Press; 2000. pp. 233-72.
8. Huffman SL, Zehner ER, Victora C. Breastfeeding and Neonatal Mortality. LINKAGES Projects, Washington, DC: Academy for Educational Development; 1999.
9. Hyder AA, Morrow RH, Wali S, et al. Burden of Disease for Neonatal Mortality in South Asia and Sub-Saharan Africa. Washington, DC: Save the Children Federation-US; 2001. pp. 1-93.
10. Johanson RB, Spencer SA, Rolfe P, et al. Effect of post-delivery care on neonatal body temperature. *Acta Paediatr.* 1992;81:859-63.
11. Moss W, Darmstadt GL, Marsh DR, et al. Research priorities or the reduction of perinatal and neonatal morbidity and mortality in developing country communities. *J Perinatol.* 2002;22(6):484-95.
12. Mutch L, Newdick M, Lodwick A, et al. Secular changes in re-hospitalization of very low birth weight infants. *Pediatrics.* 1986;78:164-71.
13. Newborn Care in South-East Asia Region (WHO/SEAR). Report of Regional Expert Group Meeting. Delhi; 1998 (November 16-17). p. 14.
14. Zaidi AK, Huskins WC, Thaver D, et al. Hospital-acquired neonatal infections in developing countries. *Lancet.* 2005;365(9465):1175-88.

# Paediatric Genetics

## INTRODUCTION

With the improvements in treatment of infectious diseases in the developed world, conditions, which are either wholly or partially genetic in their aetiology, have become more prominent as a cause of childhood morbidity and mortality. It is estimated that around one-third of admissions to paediatric wards are due to conditions with some genetic component and therefore an understanding of basic genetic principles is becoming increasingly important.

The field of medical genetics is an ever expanding one and, within the context of this text it is not possible to cover all areas of the speciality in detail. Instead, this chapter tries to provide enough basic genetic information to allow understanding of the aspects of medical genetics encountered during day-to-day paediatric practice.

In practice, clinical genetics does not differ from any other speciality, in that the clinician's ability to make a diagnosis relies on the same skills, i.e. the ability to take a detailed history, including pregnancy and family history, perform a physical examination, arrange appropriate investigations and interpret the results. However, the emphasis may be slightly different with more time being taken over the family history and the physical examination may extend to other members of the family as well as the child who is the patient.

## HISTORY

A detailed history of a child's illness is always required when a child is seen as an outpatient or admitted to hospital. Obviously if a child is admitted acutely unwell then treating the current illness is paramount, but if a genetic cause for the illness is suspected it is important, once the child's condition is stable, to return to asking questions about the child's previous health, growth and development in much more detail.

In addition to trying to ascertain genetic factors which may have contributed to the child's illness it is equally

important to look for nongenetic factors which may offer an explanation and allow a genetic cause to be excluded: for instance a history of significant perinatal asphyxia in a child with severe microcephaly and seizures or the ingestion of teratogens such as alcohol or antiepileptic medication during pregnancy if a child has multiple congenital anomalies.

Care has to be taken when drawing family trees in order to get the correct information without causing offence or distress to the family. For instance, many parents feel guilty if their child has been diagnosed with a genetically inherited condition and worry that it may have been inherited from their side of the family. In the developed world, it is not unusual for a woman to have had children by several different partners and sensitivity must be used while obtaining this information. Similarly, in other populations, asking questions about consanguineous (related) marriages may also cause concern.

Within the genetics clinic, family trees or 'pedigrees' are usually drawn to at least three generations. An example of various family trees is shown in Figure 4.1. The child, who brings the family to medical attention is usually known as the 'proband' with his parents being referred to as 'consultands'. By convention, males are represented by squares and are drawn to the left of a couple and females are represented by circles. 'Affected' individuals are shaded in, while carriers of recessive disorders and chromosome translocations are half shaded and female carriers of X-linked disorders are indicated by a central dot. Other commonly used family tree symbols are listed in Figure 4.1.

Well before people were interested in human genetics, patterns of inheritance had been recognised both in animal breeding and plant crossing experiments. In the 19th century, Gregor Mendel was the first person to propose the idea of 'recessive' genes to explain why some traits appeared to 'skip generations'. Nowadays many patterns of inheritance are recognised and often by drawing a family tree it is possible to predict the 'risk' to offspring of subsequent generations

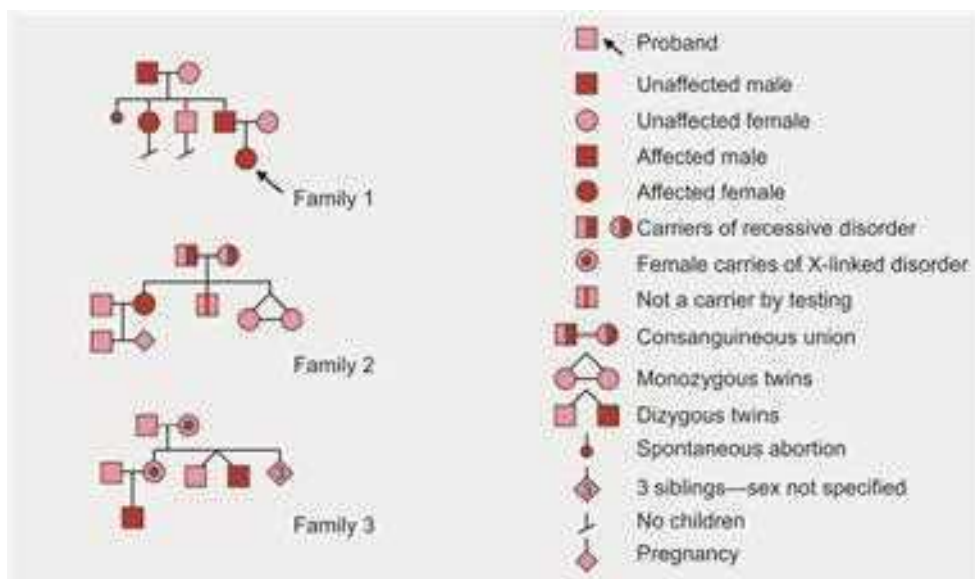


Fig. 4.1: Patterns of inheritance

even in situations where no specific genetic diagnosis has been made.

## PATTERNS OF INHERITANCE

### Autosomal Dominant Inheritance

With conditions which are autosomal dominantly inherited the condition typically appears to occur in all generations of a family and males and females are equally affected [Fig. 4.1 (Family 1)]. The important point to note with dominantly inherited conditions is that males can pass the condition to their sons and this can be a useful feature for distinguishing an autosomal dominant condition from an X-linked condition where females are sometimes 'affected'.

The clinical status of an individual is usually referred to as 'phenotype' whereas their genetic constitution is the 'genotype'. Some autosomal dominant conditions are not fully penetrant, which means that not all individuals, who inherit the mutant gene, will be clinically affected and others may be so mildly affected that the condition is not immediately noticed. For this reason an autosomal dominant condition may appear to 'skip' a generation and then return. Thus, when a condition is known to have variable penetrance it is important to exercise caution when determining the risk to the next generation, even when an individual has a normal phenotype.

Males and females affected by an autosomal dominant condition will transmit the condition to 50% of their sons and 50% of their daughters.

### Autosomal Recessive Inheritance

Typically autosomal recessive conditions only affect individuals in one generation of a family [Fig. 4.1 (Family 2)] but exceptions to this will occur when the carrier frequency of the gene in a population is high, e.g. 1:10 people of Caucasian origin are carriers of a haemochromatosis gene mutation and therefore it is not uncommon for a person who is affected by haemochromatosis to have a partner who is a carrier of the condition, resulting in the possibility of their offspring also being affected. This phenomenon is known as 'pseudodominance'. Autosomal recessive conditions may also occur in more than one generation of a family if there are many consanguineous marriages within the family.

When both parents are carriers of an autosomal recessive condition they will transmit the condition to 25% of their children whether they are male or female and 50% of their children will be carriers. A person affected by an autosomal recessive condition will have a low-risk of having an affected child, provided that their partner is not a relative and that the carrier frequency of the condition in the population is low.

### X-Linked Recessive Inheritance

X-linked recessive conditions generally only affect males and never pass from father to son [Fig. 4.1 (Family 3)]. However, occasionally a female may be affected by an X-linked recessive condition if she only has one X-chromosome (as a result of also having Turner's syndrome), if she has a skewed X-inactivation pattern (discussed later) or if she has inherited



a mutant gene on both of her X-chromosomes, which may occur if (a) her father is affected by the condition and her mother is a carrier, (b) a new mutation arises in the gene on one X-chromosome and her other X-chromosome is inherited from a parent who is affected or a carrier.

Female carriers of an X-linked recessive condition will have a 25% chance of having an affected son and a 25% chance of having a carrier daughter. All of the daughters of a male affected by an X-linked recessive condition will be carriers and none of his sons will be affected.

### X-Linked Dominant Inheritance

X-linked dominant conditions also affect both males and females and occur in several generations of a family but their distinguishing feature is that they never pass from father to son.

A female affected by an X-linked dominant condition will transmit the condition to 50% of her sons and 50% of her daughters. A male affected by an X-linked dominant condition will transmit the condition to all of his daughters and none of his sons.

### Mitochondrial Inheritance

Although the majority of DNA inherited from parents occurs within the chromosomes in the nucleus of cells, a small amount of DNA also occurs within the mitochondria, which are the organelles responsible for cell energy production. As sperm do not contain any mitochondria, conditions, which occur as a result of mutations in mitochondrial DNA, are always maternally transmitted.

The proportion of mitochondria containing the mutant gene varies from cell-to-cell in all tissues of the body and therefore an individual's phenotype will also vary depending on the proportion of mutant mitochondria in relation to normal or 'wild-type' mitochondria. It can be extremely difficult to predict the chance of a woman having an affected child, if she is either affected by or a carrier of a mitochondrial condition. The various possibilities arising in this situation are illustrated in Figure 4.2.

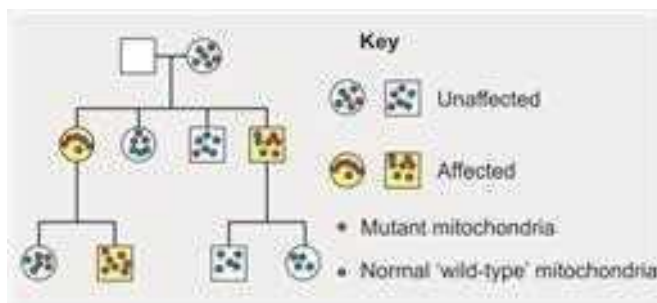


Fig. 4.2: Mitochondrial inheritance

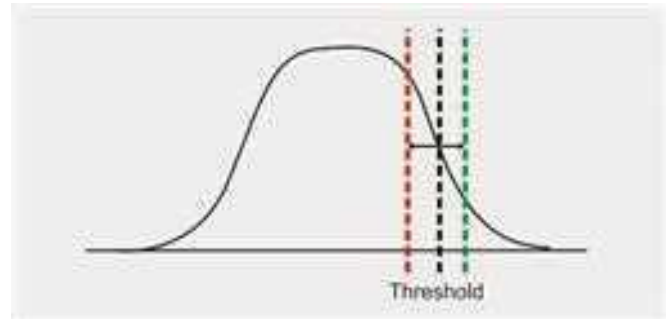


Fig. 4.3: Threshold effect

### Polygenic Inheritance

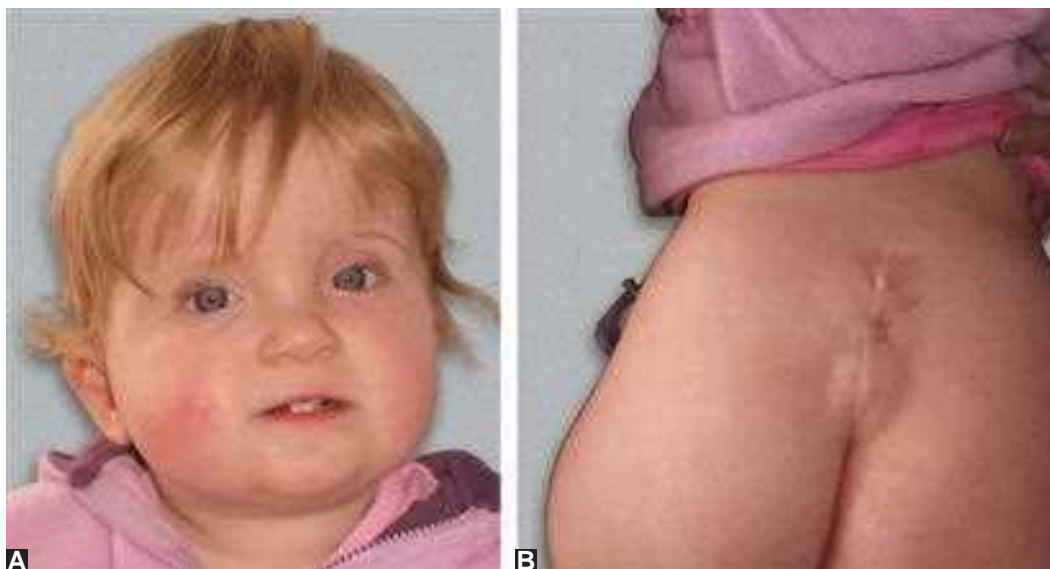
Many congenital anomalies and later onset diseases, e.g. diabetes and hypertension occur more commonly in some families than would be predicted from the population incidence of the disorder, but do not follow the patterns of single gene inheritance, described above. Such conditions are referred to as 'polygenic' or 'multifactorial' and their aetiology involves both genetic and environmental factors. In this situation the disorder only occurs if an individual inherits a sufficient quantity of 'susceptibility' genes and is also exposed to specific environmental factors. Many of these multifactorial conditions exhibit a threshold effect (Fig. 4.3) and it is only when this threshold is exceeded that the condition occurs.

For the majority of multifactorial disorders neither the susceptibility genes nor the specific causative environmental factors are known. The exception to this is perhaps illustrated with neural tube defects where the result of the MRC multivitamin trial published in 1991, concluded that the risk of neural tube defects occurring could be reduced by 60–70% with periconceptual folic acid supplementation. This in effect moved the 'threshold' to the right of the curve. Conversely, it is well-recognised that taking folic acid antagonists, such as some antiepileptic drugs, during pregnancy increases the risk of neural tube defect and in this case the threshold is shifted to the left of the curve (Figs 4.4A and B).

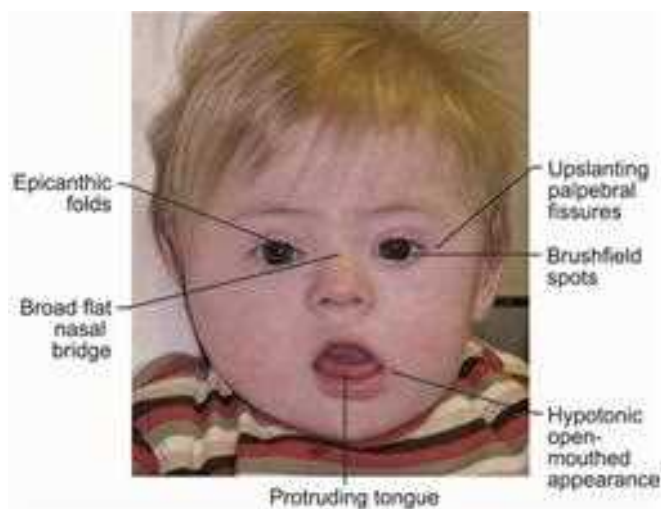
In order to predict the recurrence risk for multifactorial conditions, geneticists rely on population studies which provide 'empiric' recurrence risks. For most of the congenital anomalies the risk figures lie between 2 and 5%. If a couple have a second affected child the risk increases, since it is more likely that for this particular family genetic factors are involved.

### Clinical Examination and Dysmorphology

The clinical examination of a child within the genetics clinic does not differ in any way from that carried out elsewhere, but making a 'genetic diagnosis' often relies on the recognition



**Figs 4.4A and B:** Repaired neural tube defect in a girl who also has facial features of 'foetal valproate syndrome' (flat nasal bridge, hypertelorism, infraorbital crease, long smooth philtrum)



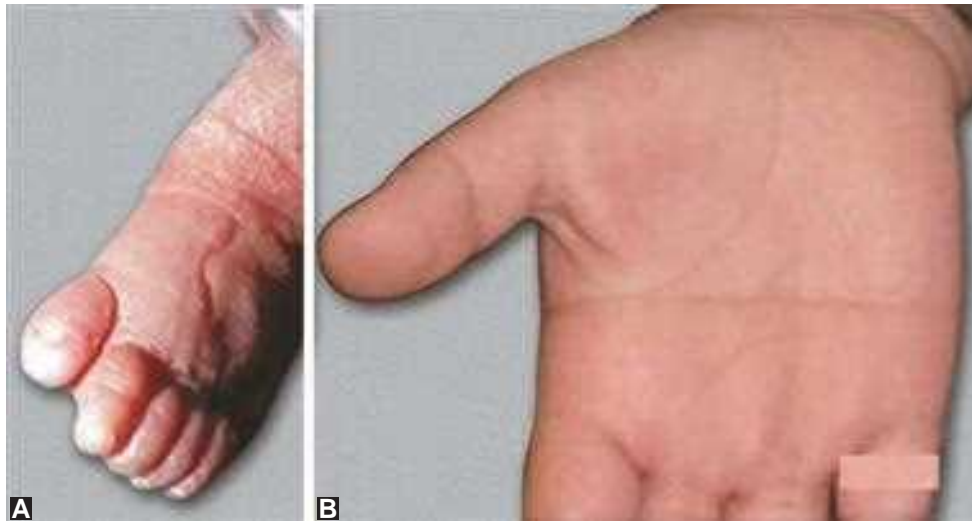
**Fig. 4.5:** Down's syndrome (trisomy 21) facial appearance



**Fig. 4.6:** Ectrodactyly (split-foot)

of patterns of clinical features and symptoms. It is only with experience that the more common 'syndromes' become easily recognised and often it is a facial 'gestalt', i.e. overall appearance, rather than individual features which suggests a likely diagnosis. For instance the child with Down's syndrome (Fig. 4.5) is easily identified by people who have no medical knowledge, because it is a relatively common condition. It is impractical to memorise the features of hundreds of genetic syndromes and modern day geneticists frequently use computerised dysmorphology databases to aid diagnosis. These databases contain information on the clinical features of syndromes compiled from the published literature and by

searching on a patient's key clinical features it is possible to obtain a list of suggested diagnoses, which aids the direction of further investigations in order to confirm or exclude a particular diagnosis. Clinical features may be regarded as 'hard handles' if they only occur with a small number of conditions, e.g. ectrodactyly (Fig. 4.6), whereas features such as single palmar creases and hypoplastic nails (Figs 4.7A and B) are 'soft signs', which occur with many different genetic diagnoses. Features such as marked asymmetry of any part of the body (Fig. 4.8) or patchy abnormalities of skin pigmentation are suggestive of 'mosaicism' and a skin biopsy should be considered.



**Figs 4.7A and B:** (A) Hypoplastic nails; (B) Single palmar crease



**Fig. 4.8:** Asymmetry

(cytogenetics) and DNA analysis (molecular genetics), which are discussed in more detail below.

### Cytogenetics

The study of chromosomes was perhaps the earliest branch of medical genetics to develop, with Hsu and Levan being the first to accurately observe human chromosomes in 1952 and the correct human chromosome number being recorded, in 1956, by Tjio and Levan.

Chromosomes are the structures in the nucleus of the cell into which DNA is packaged. In humans there are 46 chromosomes in all nucleated cells except the gametes. The 46 chromosomes occur as 23 pairs, with one copy of each pair being inherited from the mother and the other from the father. The first 22 pairs of chromosomes are the same whether an individual is male or female and are known as 'autosomes' and the remaining pair are the 'sex chromosomes'. Females have two X sex chromosomes while males have one X and one Y sex chromosome. The chromosome constitution of an individual is usually referred to as their karyotype and the normal karyotype for a female is denoted 46, XX and for a male 46, XY.

The chromosomes can only be examined in dividing cells and are best seen during the metaphase stage of mitosis. For this reason it usually takes around 1 week to get the result of a chromosome test. Various staining techniques can be used to examine chromosomes with the light microscope in order to show the 'banding pattern' along the length of each chromosome. The stain most commonly used is Giemsa which reveals dark and light regions of chromosomes rather like a bar-code (Fig. 4.9) and by searching for variations in

### INVESTIGATIONS

The diagnosis of many genetic disorders can be made on the basis of biochemistry results, e.g. sweat electrolytes in the case of cystic fibrosis or urinary glycosaminoglycans in the case of the mucopolysaccharidoses. Similarly, radiographs are an essential tool for the diagnosis of inherited skeletal dysplasias (discussed in Chapter 32). However, the investigations specific to the field of genetics are chromosome tests

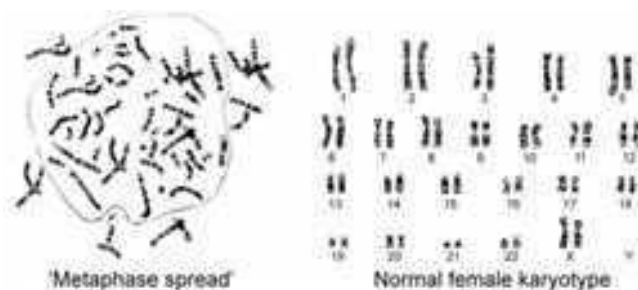


Fig. 4.9: Giemsa-banded chromosomes

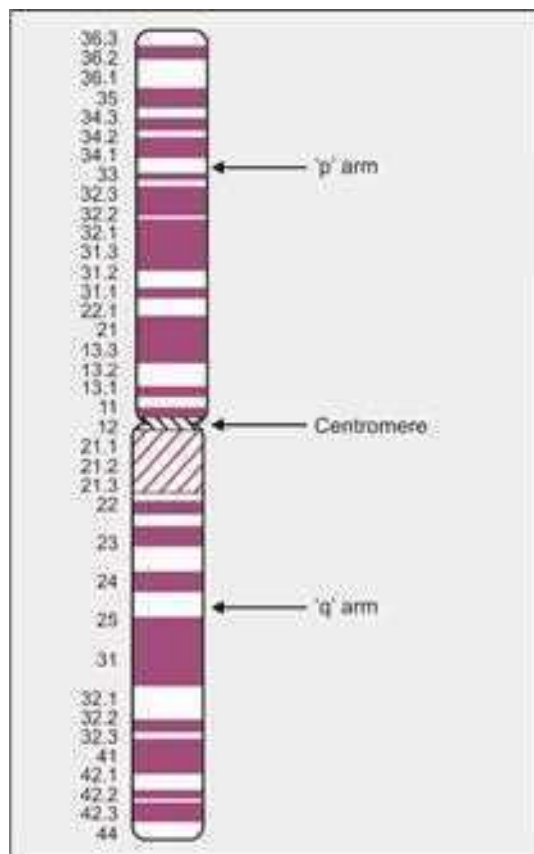


Fig. 4.10: Chromosome diagram

the pattern created by these bands, trained cytogeneticists are able to identify structural abnormalities along the length of any chromosome. The chromosomes are photographed and then arranged in their pairs starting with the largest autosome to the smallest and finally the sex chromosomes. The diagrammatic representation of a chromosome (Fig. 4.10) shows that the chromosome is divided into two arms—(1) the 'p' short arm and (2) the 'q' long arm—by the narrowed centromere region. With the larger chromosomes the 'short arms' are almost as long as the 'long arms'.

## Numerical Chromosome Abnormalities

Soon after the correct number of human chromosomes was determined it was recognised that numerical abnormalities of chromosomes were associated with clinical disorders. Numerical abnormalities can arise with both the autosomes and sex chromosomes.

### Numerical Abnormalities of Autosomes

Extra or missing copies of any of the autosomes can arise as a result of nondysjunction occurring during meiosis, which is the process by which the total chromosome number is halved during gamete formation. Numerical abnormalities of chromosomes are known as 'aneuploidy' and most autosome aneuploidies are incompatible with survival, leading to spontaneous abortions of affected pregnancies. The exceptions to this are trisomies of chromosomes 13, 18 and 21 and the clinical features of these conditions are summarised in Table 4.1.

Trisomy 13 (Fig. 4.11) and trisomy 18 (Fig. 4.12) are both associated with multiple congenital anomalies and the majority of babies born with these conditions die within the first year of life. These autosomal trisomies occur with increased frequency with increasing maternal age and tables are available for advising women of their age-related risk of having a live born baby with an autosomal trisomy. After a couple have had a child with an autosomal trisomy, the risk of recurrence for future pregnancies is around 1% and prenatal diagnosis could be offered in the form of chorionic villus sampling or amniocentesis.

The most frequent autosomal trisomies found in tissue from spontaneous abortions are trisomy 16 and trisomy 22, but these are generally only found in live born babies in the mosaic state, i.e. the situation where only a proportion of the patient's cells have the chromosome abnormality (Fig. 4.13). Such mosaic aneuploidies are often only identified by carrying out chromosome analysis of a fibroblast culture from a skin biopsy. Analysis of skin chromosomes should always be considered if a patient has marked asymmetry or if a diagnosis of Pallister-Killian is being considered. Pallister-Killian arises as a result of mosaic tetrasomy 12p, i.e. some cells have two additional copies of the short arms of chromosome 12 joined together to form an additional chromosome. The clinical features of Pallister-Killian syndrome are summarised in Table 4.2.

### Numerical Abnormalities of Sex Chromosomes

It is unusual for abnormalities of the sex chromosome number to be detected in newborn babies as they are not usually associated with physical abnormalities. The exception to this may be girls affected by Turner's syndrome, who have only one X-chromosome (i.e. a 45, XO karyotype) and who

**Table 4.1:** Autosomal trisomies

Trisomy	Name	Approximate birth incidence	Main clinical features
13	Patau's syndrome	1:5,000	Cleft lip and palate, microcephaly, holoprosencephaly, seizures, severe learning disability, scalp defects, colobomata, microphthalmia, cardiac defects, exomphalos, polydactyly
18	Edwards syndrome	1:3,000	Low birth weight, female preponderance, small facial features, prominent occiput, severe learning disability, low set malformed ears, cardiac defects, renal anomalies, flexion deformities of fingers, rocker-bottom feet
21	Down's syndrome	1:700	Hypotonia, flat occiput, up-slanting palpebral fissures, epicanthic folds, Brushfield spots, flat nasal bridge, protruding tongue, learning disability, cardiac defects, intestinal atresia, imperforate anus, Hirschsprung's disease

**Table 4.2:** Pallister-Killian syndrome—clinical features

<i>Pallister-Killian syndrome</i>	
Neurological features	Profound learning disability, seizures profound hypotonia
Dysmorphic facial features	General 'coarse' appearance, high forehead, sparseness of hair in frontal region in infancy, hypertelorism, epicanthic folds, flat nasal bridge, large mouth with down turned corners, macroglossia, abnormal ears
Other features	Pigmentary skin anomalies, short neck, diaphragmatic hernia, supernumerary nipples



**Fig. 4.11:** Trisomy 13—note exomphalos and polydactyly



**Fig. 4.13:** Mosaic trisomy 22—note marked facial asymmetry



**Fig. 4.12:** Trisomy 18—typical overlapping fingers

may have congenital malformations (Fig. 4.14). Even in the absence of structural malformations, a diagnosis of Turner's syndrome may be suspected in a newborn infant because of intrauterine growth retardation and the presence of lymphoedema. This can, on occasions, persist into adulthood (Fig. 4.14).

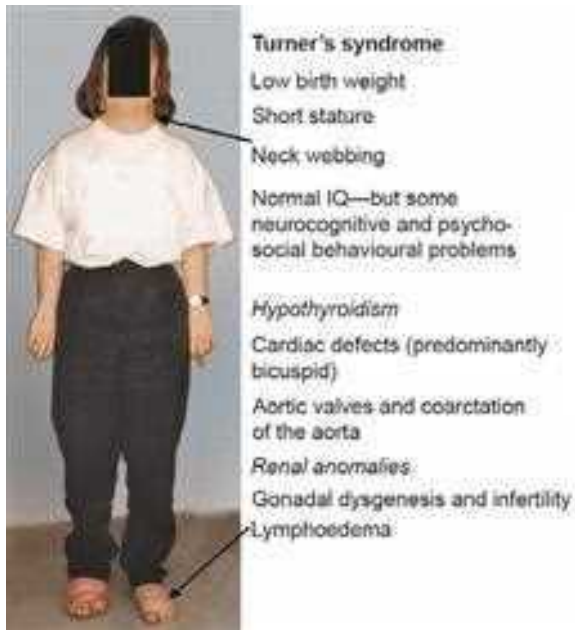


Fig. 4.14: Clinical features of Turner's syndrome

A 47, XYY karyotype is often detected by chance when chromosomes are being checked for an unrelated reason, e.g. a family history of a structural chromosome abnormality, as this chromosome abnormality is not usually associated with any phenotypic effect. There are some studies which suggest that behaviour abnormalities are more common in boys with 47, XYY karyotypes, but this probably just reflects the fact that boys with behavioural abnormalities are more likely to have their chromosomes checked. An additional X-chromosome present in a male (i.e. 47, XXY karyotype) is generally referred to as Klinefelter's syndrome and in a female (i.e. 47, XXX karyotype) is called triple X-syndrome.

In females, with normal karyotypes, only one X-chromosome is active in each cell and the other is condensed into a structure called a 'Barr body'. The X-chromosome which is active varies from cell-to-cell, usually with the maternal X being active in 50% of cells and the paternal X being active in the remaining 50%. If this is not the case it is referred to as 'skewed X-inactivation'. In children with additional copies of the X-chromosome, only one X-chromosome remains activated and the additional copies are inactivated to form extra Barr bodies.

Males with Klinefelter's syndrome are usually diagnosed in adulthood as they are taller than would be predicted from their parental heights and have hypogonadism, resulting in infertility.

Females with triple X-syndrome are also taller than average and some may experience fertility problems. Around 30% of girls with triple X-syndrome have significant learning difficulties and mild learning difficulties may occur in a small

proportion of males with 47, XXY or 47, XYY karyotypes. Multiple extra copies of the sex chromosomes can also occur, e.g. 48, XXYY, 48, XXXX or even 49, XXXXY karyotypes. In general higher numbers of additional X-chromosomes are associated with significant learning difficulties.

The frequency of Turner's syndrome is around 1:3,000 female births, while the frequency of Klinefelter's syndrome, triple X-syndrome and 47, XYY is around 1:1,000 live births.

Sex chromosome aneuploidies are not associated with increased maternal age and the recurrence risk for future pregnancies is not increased.

### Structural Chromosome Abnormalities

Structural chromosome abnormalities are termed 'unbalanced' if there is loss or gain of chromosomal material and 'balanced' if the overall amount of chromosomal material remains unchanged. Generally speaking balanced chromosome abnormalities are unlikely to cause any adverse effect. The main categories of structural chromosome abnormalities are listed below and illustrated in Figure 4.15.

#### Robertsonian Translocations

A Robertsonian translocation is the fusion of two of the smaller chromosomes at their centromeres. During this process the short arms of the chromosomes are lost, but as these contain no essential genetic material, no harmful effect occurs. A carrier of a balanced Robertsonian translocation will have a total of 45 chromosomes as the two fused chromosomes are counted as one. Similarly, the correct cytogenetic nomenclature for a person with an unbalanced

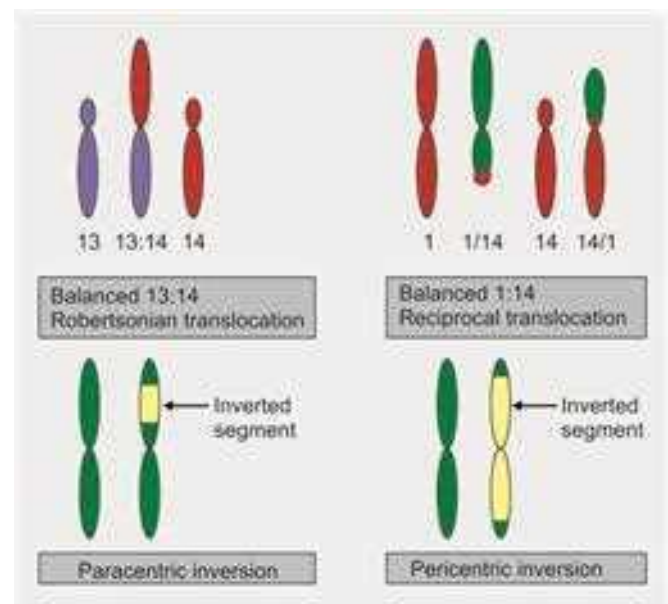


Fig. 4.15: Structural chromosome rearrangements

Robertsonian translocation, describes them as having 46 chromosomes, but they will of course have three copies of the long arms of one of the chromosomes involved in the translocation.

Carriers of balanced translocations are at risk of having children with unbalanced chromosomes. The actual risk varies depending on: (a) the chromosomes involved in the translocation—highest when chromosome 21 is involved and (b) the sex of the parent who is a carrier—higher when it is the mother. It is important to recognise that all of the children of a carrier of a 21:21 Robertsonian translocation, will be affected by Down's syndrome.

### Reciprocal Translocations

A reciprocal translocation is the exchange of segments of chromosomal material between nonidentical chromosomes, usually two chromosomes are involved but complicated exchanges between several chromosomes can occasionally occur. This is detected by there being a disruption to the normal banding pattern along the length of the chromosomes involved.

Carriers of balanced reciprocal translocations are healthy but as they produce a proportion of chromosomally abnormal gametes they may present with infertility, particularly in males, or recurrent miscarriages. Sometimes an individual will be identified as being a carrier of balanced reciprocal translocation following the birth of child with congenital malformations, dysmorphism or learning disability, if investigations reveal the unbalanced form of the translocation in the child. The birth of a live born child with chromosomal imbalance arising from a reciprocal translocation, is more likely to occur if the length of the chromosomal segments involved in the translocation represent less than 5% of the overall length of all 46 chromosomes.

### Inversions

An inversion is the term used to describe a segment of chromosome, which has broken away and then rejoined in the same position but rotated through 180°. If the inverted segment is confined to one arm of the chromosome it is termed a 'paracentric inversion' and if the segment spans the centromere it is termed a 'pericentric inversion'. Chromosomal inversions usually have no phenotypic effect, but they interfere with meiosis and again may result in chromosomally abnormal gametes being produced. The chromosome abnormalities arising from paracentric inversions are unlikely to be compatible with survival and are, therefore, more likely to result in recurrent early miscarriages. Pericentric inversions, on the other hand, may result in small chromosomal deletions or duplications

and can result in live born children with malformations or learning disability arising from chromosomal imbalance.

### Chromosomal Deletions and Duplications

Deletions or duplications of chromosomal segments may arise and most of these are unique to the individuals in whom they are identified. However, there are some regions of chromosomes which are more prone to deletions or other rearrangements. These are termed 'subtelomeric' if they occur at the ends of the chromosomes and 'interstitial' if they occur elsewhere. It is now clear that many of these recurrent rearrangements give rise to recognisable dysmorphic syndromes (Table 4.3 and Fig. 4.16) and that some of the variability in the features of these syndromes is due to the size of the deletion and the number of genes which are missing as a result.

Many chromosomal deletions are visible when observing chromosomes with the light microscope but others are too small to be seen and require a specialised technique, called fluorescent *in situ* hybridisation (FISH) to be detected. FISH is basically a molecular genetic technique (discussed later) whereby a fluorescent probe is attached to the region of interest of the chromosome. In the normal setting two fluorescent signals should be seen, i.e. one on each of the chromosome pair, but if that particular region of chromosome is deleted, only one signal will be seen. In practice two different probes of different colours are used—one purely to identify the particular chromosome of interest and the other for the specific region (Fig. 4.17).

### Uniparental Disomy and Imprinting

Uniparental disomy (UPD) is a relatively recently recognised form of chromosome abnormality. It is defined as the 'inheritance of a pair of homologous chromosomes from one parent', with no copy of that chromosome being inherited

**Table 4.3:** Chromosomal deletion syndromes

Chromosome segment	Syndrome
4p16.3	Wolf-Hirschhorn syndrome
5p15.2	Cri-du-Chat syndrome
5q35	Sotos syndrome
7q11.23	Williams syndrome
11p15.5	Beckwith-Wiedemann syndrome
13q14.11	Retinoblastoma
15q12	Angelman and Prader-Willi syndromes
16p13.3	Rubinstein-Taybi syndrome
17p11.2	Smith-Magenis syndrome
22q11.2	DiGeorge/Velocardiofacial syndrome



Fig. 4.16: Clinical features of some chromosome microdeletion syndromes



Fig. 4.17: FISH technique used to detect the 22q11.2 deletion associated with velocardiofacial syndrome

from the other parent. There are various mechanisms by which UPD can arise but it is thought that it most commonly occurs as a result of 'trisomic rescue', i.e. the loss of one copy of a chromosome during early cell division in an embryo which was originally destined to be trisomic for that chromosome.

With most autosomal genes, both the paternal and maternal copies of the gene are expressed, but a small

number of genes are 'imprinted', which means that only the maternal or paternal (depending on the particular gene) copy is expressed. Therefore, although UPD can occur without clinical effect, for certain chromosomes it can mimic a deletion of an imprinted gene, e.g. Angelman syndrome, can arise as a result of a deletion of the maternal copy of the chromosome region 15q12, but it will also occur if a child has paternal UPD of chromosome 15, since there will be no maternal copy of 15q12 present. Other conditions arising as the result of abnormalities of imprinted genes are summarised in Table 4.4. 'Isodisomy' is a form of UPD where a child inherits two identical copies of the same chromosome from one parent and 'heterodisomy' is the inheritance of a homologous pair of chromosomes from one parent. Thus, another consequence of UPD may be the occurrence of an autosomal recessive disorder in a child, when only one of

Table 4.4: Syndromes due to abnormalities in the expression of imprinted genes

- Angelman syndrome
- Prader-Willi syndrome
- Beckwith-Wiedemann syndrome
- Russell-Silver syndrome
- Transient neonatal diabetes





**Fig. 4.18:** Infant with multiple congenital anomalies due to maternal UPD 16

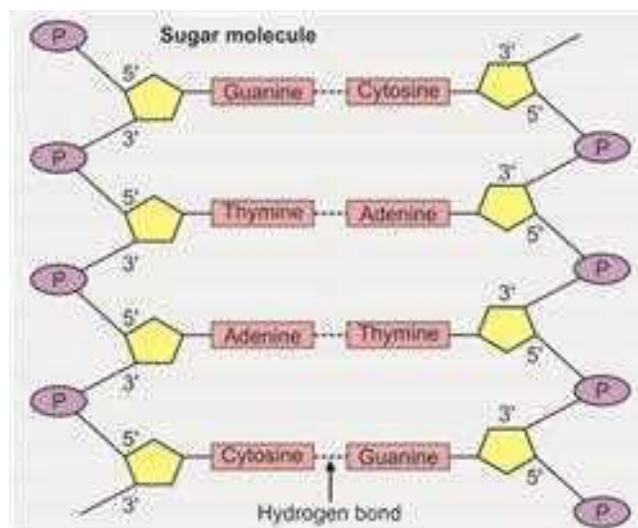
the parents is a carrier of the disorder. The first case of UPD reported was in fact a child with short stature and cystic fibrosis, which occurred as a result of maternal isodisomy of chromosome 7.

Another consequence of UPD of certain chromosomes is a recognisable pattern of congenital malformations, e.g. UPD of chromosome 16 can give rise to intrauterine growth retardation, cardiac defects, imperforate anus, scoliosis, hypospadias and hernia (Fig. 4.18).

### Molecular Genetics

Before discussing the more clinical aspects of molecular genetics, it is useful to review some basic genetic principles. Deoxyribose nucleic acid (DNA) is the genetic template required to construct all the enzymes and proteins, which are necessary for the formation and function of the human body. DNA consists of strands of nucleic acids, containing the bases, adenosine, guanine, cytosine and thymine, held together by a sugar-phosphate backbone (Fig. 4.19). Each DNA molecule exists as two of these strands wrapped around each other to form a 'double helix'. The variable part of the DNA chain is the order of the bases along the backbone and the two strands of DNA are linked by hydrogen bonds between these bases. As a result of their shapes adenine always pairs with thymine and cytosine always pairs with guanine.

It is the order of the DNA bases which form the 'genetic code' required for the production of amino acids and subsequently proteins. The code is a triplet code, as each three bases codes for an amino acid or provides the instruction 'stop' at the end of a peptide chain. As there are 43, i.e. 64 possible combinations of these bases and only 20 amino acids, the code is said to be 'redundant' and more than one triplet may code for the same amino acid. This can obviously be useful when it comes to DNA mutations arising since not all base substitutions will alter the sequence



**Fig. 4.19:** DNA structure

of amino acids in a protein and therefore the protein function will not be lost. Such harmless substitutions are referred to as 'harmless' or 'benign' polymorphisms.

In order to understand how this system works it is necessary to look at the DNA molecule, shown in Figure 4.19, more closely. The deoxyribose sugars of the DNA backbone each have two hydroxyl groups, which occur at the 3 prime and 5 prime positions (denoted 3' and 5' respectively). The phosphate molecules join the sugar molecules together by forming a phosphodiester bond between the 3' hydroxyl group of one deoxyribose molecule and the 5' hydroxyl group of another. This gives the DNA strand a direction, running from the free 5' hydroxyl group of the first deoxyribose molecule to the free 3' hydroxyl group of the last. The two strands of DNA will of course be 'complimentary' in view of the base pairing, with one strand running in one direction and the other in the opposite direction.

DNA replication is an extremely complicated process, whereby the strands of DNA are separated and copied to produce new daughter strands. The process is initiated by the enzyme DNA polymerase and as the initial strands are separated, new deoxyribonucleoside triphosphates are added in a 5' to 3' direction. The process is said to be semiconservative as each new DNA molecule will consist of one of the initial 'parent' strands bound to a new 'daughter' strand.

It was originally thought that genes consisted of a length of DNA providing the triplet code for the necessary amino acids to form a peptide chain. However, it is now recognised that this is not the case and the DNA sequence of each gene contains regions in between its protein coding sequence, known as intervening sequences (IVS). The nomenclature generally used is 'exons' (protein coding sequences) and

'introns' (intervening sequences). There are particular DNA codes which herald the start (TAG) and end of protein synthesis (TAA, TAG or TGA). Similarly, the dinucleotides GT and AG are found at the start and end of introns, respectively. Other particular nucleotide codes, which may be some distance away from the first exon of a gene, are also important for protein synthesis and are known as promoter regions.

The first stage of protein synthesis is known as transcription and involves the processing of messenger RNA (mRNA). DNA acts as a template for the production of mRNA and is read in a 5' to 3' direction. The process is initiated by enzymes known as RNA polymerases, which separate the strands of DNA. As with DNA replication the order of bases along the strand of mRNA, which is produced, are complimentary to the original DNA bases. The only difference between DNA and RNA is that the backbone sugar is ribose rather than deoxyribose and in RNA the base thymine is replaced by the base uracil. The primary transcript of mRNA, which is produced, contains the entire DNA coding region, including introns and exons. The mRNA then undergoes a number of processing steps, which result in the introns being cleaved out and the exons being spliced together (Fig. 4.20). Finally, the mRNA is modified by the attachment of various adenylic acids and protein molecules, which serve to protect the mRNA as it passes from the nucleus into the cytoplasm, in preparation for protein synthesis.

The process of protein synthesis also involves several different steps, namely 'initiation', whereby the ribosome is assembled on the mRNA, 'elongation', where complimentary tRNA molecules attach to each codon in turn, resulting in the addition of amino acids to the growing peptide chain and finally 'termination' when the polypeptide is released into the cytoplasm.

Not surprisingly with such a complicated process, errors (mutations) can arise and this results in the genetically inherited single gene disorders. There are various different types of mutation and these are summarised in Table 4.5.

## Molecular Genetic Investigations

### *Southern Blotting*

This is one of the older techniques used for DNA analysis, but it is still sometimes needed for detecting large genomic rearrangements, such as the large trinucleotide repeats which can occur in patients with myotonic dystrophy. The Southern blotting technique is labour intensive and it can take several weeks to obtain results when this process is used.

### *Polymerase Chain Reaction*

For many single gene disorders 'polymerase chain reaction' (PCR) is now the method of choice for DNA analysis. This process allows the analysis of short sequences of DNA which have been selectively amplified and tests looking for common recurring mutations, such as in cystic fibrosis, or known

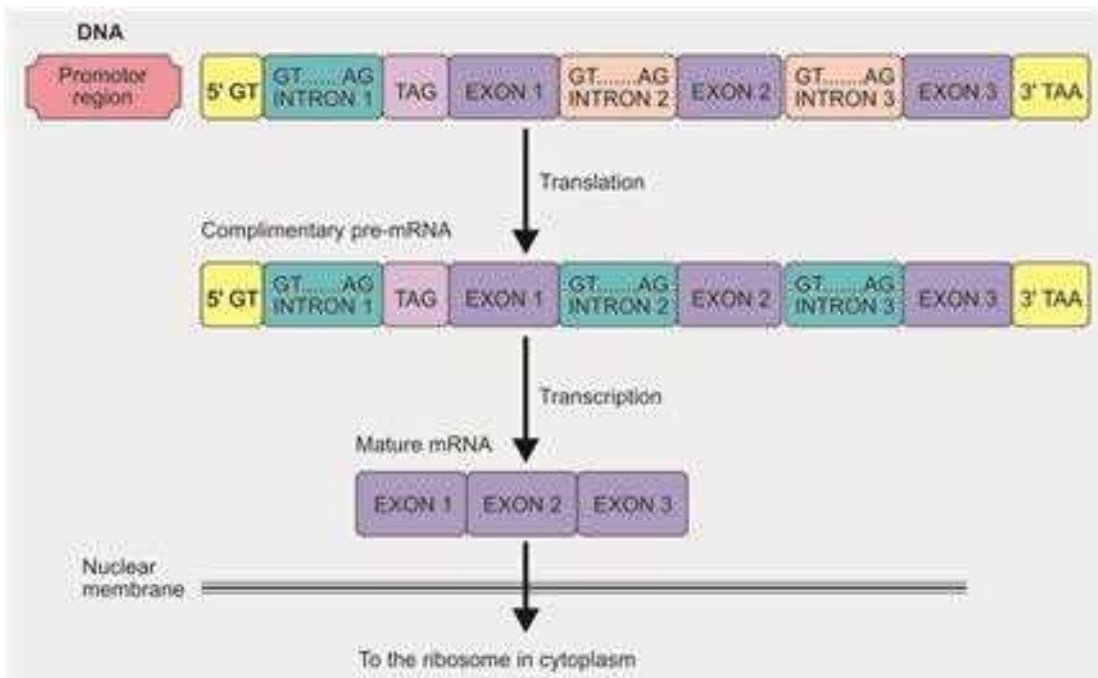


Fig. 4.20: DNA translation and transcription

**Table 4.5:** Types of mutation

Type of mutation	Outcome
Point mutation:	A single base substitution
a. Missense mutation	Base change results in different amino acid
b. Nonsense mutation	Base change results in 'stop' and a shortened protein
Insertion or deletion	Alteration of the reading frame
	If a complete codon is deleted an amino acid will be missing from the protein, which may or may not affect function
Trinucleotide repeat	After a particular threshold is expansion reached protein function is altered
	Severity of the disorder is generally related to the size of the expansion

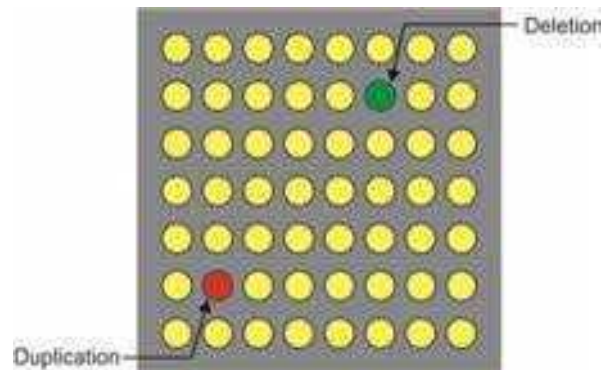
familial mutations which have previously been detected by other methods, can provide results within 48 hours.

### DNA Sequencing

This type of testing reveals the specific sequence of bases within a region of DNA and compares them to reference sequence data in order to determine if any substitutions, deletions, etc. have occurred. Much of this type of DNA testing is now computerised but it can still take lengthy periods of time to get results, particularly if the gene being investigated is large.

### Molecular Cytogenetics

With advancing technology the distinction between cytogenetic tests and molecular genetic tests is disappearing and more and more frequently molecular genetic techniques are being used to detect chromosome abnormalities. The two main techniques used are: (1) Multiple ligand probe amplification (MLPA)—This technique is a new high resolution technique for detecting copy number variation of a large number of DNA segments simultaneously and it can, therefore, be used to provide a rapid screen for deletions and duplications at a number of sites throughout the genome. For instance it can be used to screen for very small chromosomal deletions or duplications in children with learning disability and dysmorphism, in whom conventional cytogenetic testing has failed to reveal any abnormality. (2) Array comparative genomic hybridization (Array CGH)—With this technique a DNA sample from the patient and a 'normal control' DNA sample are labelled with different coloured fluorescent dyes (usually red and green) and spread onto a solid surface, which has previously been spotted with short stretches of DNA. The samples bind to these areas of DNA and where there is no difference between the patient and control samples the 'spots' look yellow and where the patient has additional chromosomal material (i.e. a duplication) the spot looks red or is missing chromosomal material (i.e. a deletion) the spot looks green (Fig 4.21). These spots are subsequently scanned and a computerized analysis is carried out to determine the specific regions of chromosomal imbalance and assess which genes

**Fig 4.21:** Array CGH

are likely be affected by the loss or gain of chromosomal material.

### Single Gene Disorders

The clinical features of many of the single gene disorders have been discussed in other chapters throughout this book, but it may be useful to look at a few specific disorders from a genetics perspective.

#### Neurofibromatosis Type 1

Neurofibromatosis type 1 (NF1) (von Recklinghausen's disease) is one of the most common genetically inherited disorders, having an incidence of approximately 1:3,000. It occurs as a result of mutations in the NF1 gene on chromosome 17 and is essentially fully penetrant, although the phenotype can be extremely variable. In around half of the affected individuals there is a family history of the condition and in the remainder the condition has occurred as a result of new mutations. The main clinical features are: café au lait patches (Fig. 4.22) which are usually present by 5 years of age, cutaneous neurofibromata, iris Lisch nodules and axillary and groin freckling. Most affected individuals are shorter than average and have larger than average head circumferences. Mild to moderate learning difficulties are common. Regular

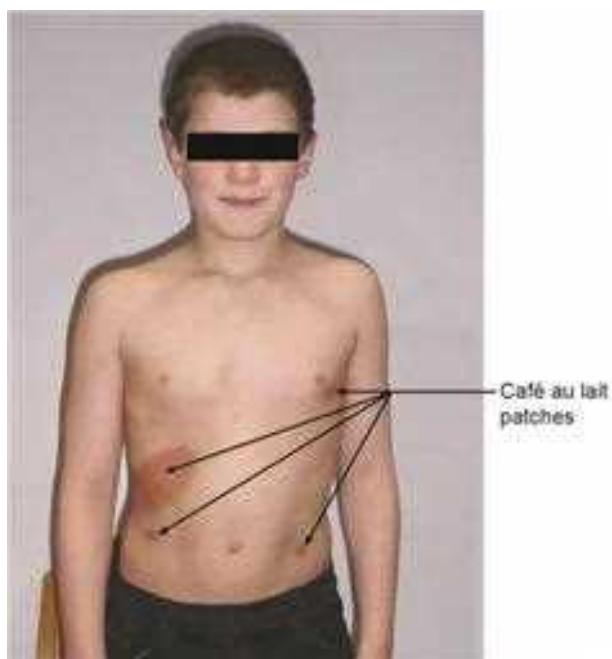


Fig. 4.22: Boy with neurofibromatosis type 1



Fig. 4.23: Plexiform neurofibroma

follow-up is required as a small proportion of people with NF1 develop more severe complications such as pseudoarthroses (present from birth), plexiform neurofibromata of the head and neck (usually present within the first year of life), optic gliomata (usually present by 6 years of age), plexiform neurofibromata of other parts of the body as seen in Figure 4.23 (usually present before puberty) and scoliosis (usually present between age 6 years to puberty).

In adulthood, other complications such as hypertension (both essential and secondary to renal artery stenosis or pheochromocytoma) and malignant peripheral nerve sheath tumours may also occur so follow-up is generally life long.

The NF1 gene is a very large gene and mutation analysis is possible, but as NF1 can usually be easily diagnosed on clinical grounds, genetic testing is rarely necessary.

NF1 should not be confused with neurofibromatosis type 2 (NF2), which is a completely separate disorder due to a gene on chromosome 22. Although patients affected by NF2 may have café au lait patches, they seldom have six or more and they do not have the axillary and groin freckling found in NF1. The most common presenting feature is bilateral vestibular schwannomas.

### Tuberous Sclerosis

Tuberous sclerosis complex (TSC) occurs with an incidence of 1:5,000–6,000. It can occur as a result of mutations in two different genes, TSC1 (located on chromosome 9) and TSC2 (located on chromosome 16). The condition is now thought to be fully penetrant and recurrences which have occurred when parents are apparently unaffected are now recognised to be due to one of the parents having minimal clinical features such as periungual fibromata (Fig. 4.24) and the phenomenon of 'gonadal mosaicism', whereby one of the parents is a carrier of the mutation only in their gametes.

TSC is a multisystem disorder with extreme variability in the phenotype, even within one family. The clinical features are divided into major features (facial angiofibromata, ungual and periungual fibromata, forehead plaques, hypomelanotic macules, shagreen patches (connective tissue naevi), multiple retinal hamartomata, cortical tubers, subependymal nodules, subependymal giant cell astrocytomata, cardiac rhabdomyomata, lymphangiomyomatosis and renal angiomyolipomata) and minor features (dental enamel pits, hamartomatous rectal polyps, bone cysts, cerebral white matter radial migration lines, gingival fibromata, non-renal hamartomata, retinal achromic patches, 'confetti' skin lesions and multiple renal cysts). The clinical diagnosis is based on the presence of two major or one major plus two minor features. In the most severe cases TS can present with infantile spasms and such children can remain profoundly



Fig. 4.24: Periungual fibroma in patient with tuberous sclerosis

handicapped with difficult to control seizures throughout their lives. In milder cases mild to moderate learning disability may be present but some individuals affected by TS have completely normal intelligence. Regular follow-up is again important particularly with regard to the possibility of renal complications.

Mutation analysis is available for both TSC1 and TSC2 and prenatal diagnosis is possible if a mutation is identified.

### Marfan's Syndrome

Marfan's syndrome has an incidence of 1:5,000–10,000 and in the majority of affected individuals the condition is due to mutations in fibrillin 1 (FBN1) on chromosome 15. It is a disorder of collagen and is, therefore, also a multisystem disorder affecting primarily the eye, the skeletal system and cardiovascular system. Individuals affected by Marfan's syndrome are usually disproportionately tall with long limbs and arachnodactyly (long fingers and toes) (Fig. 4.25). However, as many people who are tall with long arms and legs do not have Marfan's syndrome it is necessary that patients meet strict clinical criteria, known as the Ghent's criteria, before the diagnosis can be made. The main clinical features included in the Ghent's criteria are: disproportionate stature, pectus excavatum or carinatum, long fingers, flat feet, protrusion acetabulae (an abnormality of the hip identified by X-rays), dental crowding, joint hypermobility, flat cheek bones, ectopia lentis and other eye abnormalities, dissection or dilatation of the ascending aorta, mitral valve prolapse and spontaneous pneumothoraces.

Although the ocular complications and aortic root dilatation and dissection, associated with this condition, are

more common in adulthood long-term follow-up is required from the time of diagnosis. The diagnosis of Marfan's syndrome in the past was mainly based on clinical features but mutation analysis can now be used in combination with clinical features and in families where a mutation is identified prenatal diagnosis is possible.

### Myotonic Dystrophy

Myotonic dystrophy (dystrophia myotonica) has an incidence of around 1:8,000 and as the name suggests is a muscle wasting disease. However, it too, is a multisystem disorder and can be of very variable severity. The majority of people affected by myotonic dystrophy have myotonic dystrophy type 1 (DM1) due to abnormalities of the DMPK gene on chromosome 19. Myotonic dystrophy type 2 (DM2) is due to abnormalities of the ZNF9 gene on chromosome 3 and is much rarer. DM1 is an example of a condition due to a "triplet repeat expansion". Other trinucleotide repeat disorders which may be encountered in paediatric practice are Fragile X-syndrome, Friedreich's ataxia and juvenile onset Huntington's disease.

In the case of myotonic dystrophy the repeated trinucleotide is CTG and the normal size is 5–35 repeats. In very general terms the age of onset and severity of symptoms relates to the size of the expansion of this repeat, although it is not possible to predict with accuracy an individual's prognosis from their expansion size. Like other triplet repeat disorders, myotonic dystrophy exhibits the phenomenon of anticipation. Anticipation is seen because the expanded trinucleotide region is unstable and therefore expands further



Fig. 4.25: Clinical features of Marfan's syndrome

as it passes from one generation to the next, resulting in symptoms occurring earlier and with greater severity in each successive generation. For this reason it is particularly important to take a detailed three-generation family history as the older, more mildly affected relatives may only have single symptoms, such as cataracts or diabetes, which may otherwise be overlooked.

The clinical features of DM1 are: muscle disease [muscle weakness and myotonia (difficulty in relaxing the muscles after contraction)], GI tract symptoms (as smooth muscle is also affected patients often complain of constipation, colicky abdominal pain and problems with bowel control), cardiovascular disease (conduction defects may lead to sudden death), respiratory problems (alveolar hypoventilation due to diaphragmatic and probably also a central component, post-anaesthetic respiratory depression can be significant and care should be taken), ocular problems (subcapsular cataracts and retinal abnormalities), CNS

(major cognitive dysfunction is unusual with adult onset disease but personality traits such as apathy, with marked daytime sleepiness and stubbornness are well-recognised) and endocrine problems (testicular atrophy—sometimes resulting in male infertility, recurrent miscarriages, diabetes mellitus, frontal balding).

Congenital myotonic dystrophy is a severe form the disorder and almost always occurs when the condition is transmitted by the mother and generally only if the mother has symptomatic disease. Affected neonates have profound hypotonia and usually require prolonged ventilatory assistance. Survivors have learning disabilities in addition to the physical features of the disease.

---

## BIBLIOGRAPHY

1. Rimoin DL, Connor JM, Pyeritz RE, Korf BR (Eds). Principles and Practice of Medical Genetics, 5th edn. Edinburgh: Churchill Livingstone; 2007.

# Nutrition

## PROTEIN-ENERGY MALNUTRITION AND MICRONUTRIENT DEFICIENCIES IN CHILDHOOD

### PROTEIN-ENERGY MALNUTRITION

Protein-energy malnutrition (PEM) is one of the most common childhood illnesses. Almost 30% of under-five children in the developing world suffer from PEM. On a blueprint agreed to by all countries to overcome the pervasive problems of poverty, malnutrition, diseases and inequity, the United Nations has set the Millennium Development Goals (MDGs) to be achieved by the year 2015. The non-income poverty component of the MDG 1 is to reduce by half the proportion of people suffering from hunger (and malnutrition). The fourth MDG is to reduce by two-thirds the mortality rate among under-five children. Neither of these goals will be achieved unless meaningful and concerted efforts are made to combat and control childhood PEM. The prevalence of child malnutrition in countries of sub-Saharan Africa is less than that in many countries in Asia, but it is gradually increasing which is a matter of great concern.

Marasmus, a type of PEM characterised by wasting, has been recognised for centuries. Hinajosa in Mexico published the earliest account of kwashiorkor, a severe form of PEM characterised by oedema, in 1865. The acuteness of kwashiorkor has been the focus of attention of nutritionists and as many as 70 names have been given to this condition in different parts of the world. Cicely Williams first introduced the name kwashiorkor in 1935, which in the Ga language of West Africa means “the disease of the deposed child”. This literally refers to the child who develops oedema after being weaned with starchy gruels following the birth of a sibling who is breastfed.

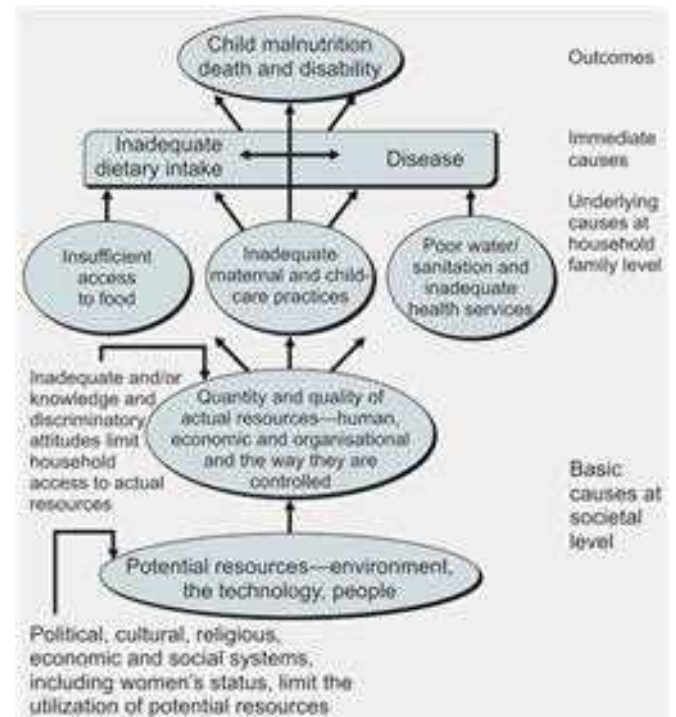
### CAUSES OF PEM

Malnutrition due to primary lack of food and interplay of infections is known as primary malnutrition, which is responsible for most of the 112 million children suffering

from moderate malnutrition in the developing world. Malnutrition occurring as a result of chronic diseases such as chronic kidney, liver or heart disease is known as secondary malnutrition. Although lack of food and repeated infections including diarrhoea and pneumonia are the immediate, precipitating causes of malnutrition, the root causes are political in nature interlaced with issues of social and gender inequity particularly of income and education (Fig. 5.1).

### CLASSIFICATION OF PEM

PEM can be classified best on the basis of anthropometric measurements (comparing body weight and/or height/length



**Fig. 5.1:** Causes of child malnutrition  
(Source: The state of the world's children, 1998)

with that of reference data of healthy children). The reference data so far used is the National Centre for Health Statistics (NCHS) median. The WHO has introduced a new standard in 2005, which is based on data of children from Asia, Africa, North and Latin America who were exclusively breastfed up to 6 months of age, and therefore is more representative of a true standard for children globally. Weight-for-age (WA), height-for-age (HA) and weight-for-height (WH) are the three anthropometric indices used in assessing nutritional status (Table 5.1). Classification according to WA is known as Gomez classification. Classification by WH or by HA is also called Waterlow classification. A low WA indicates undernutrition, a low WH wasting or acute malnutrition, while a low HA indicates stunting or chronic malnutrition. Although assessment by WA involves the measurement of weight only and is convenient, a disadvantage of using WA is that the age of children is not reliably known in many communities. Wasting and stunting are commonly seen in children between the ages of 1 year and 2 years, but by 3–4 years of age, children are more stunted than wasted. This indicates that these children have stopped growing in height but may have a normal WH.

Nutritional status is also expressed in terms of standard deviation (SD) or Z score of an anthropometric index such as WH. This score indicates deviation of a child's nutritional status from median reference values.

$$\text{SD score} = \frac{\text{Individual's value} - \text{Median value of reference population}}{\text{SD value of reference population}}$$

Malnutrition is defined as less than 2 standard deviations from the median (<2 Z scores). WA, HA and WH less

**Table 5.1:** Quantitative classification of PEM based on percentage of NCHS median reference values

<i>Weight-for-age</i>	
Well-nourished	90–120%
First degree (mild undernutrition)	75–89%
Second degree (moderate undernutrition)	60–74%
Third degree (severe undernutrition)	< 60%
<i>Weight-for-height</i>	
Well-nourished	90–120%
Grade I (mild wasting)	80–89%
Grade II (moderate wasting)	70–79%
Grade III (severe wasting)	< 70%
<i>Height-for-age</i>	
Well-nourished	95–110%
Grade I (mild stunting)	90–94%
Grade II (moderate stunting)	85–89%
Grade III (severe stunting)	< 85%

than –3 Z constitute severe underweight, severe stunting and severe wasting respectively.

The Wellcome classification is a clinical classification for children admitted to a hospital or a nutrition unit. It is based upon WA and the presence or absence of nutritional. A child with a WA less than 60% and no oedema is said to have marasmus while a child with WA greater than 60% and has kwashiorkor. Marasmic kwashiorkor is the condition where WA is less than 60% and there is severe weight reduction, gross wasting of muscle and tissue beneath the skin, stunting, and no characterised marasmus, usually seen in infancy. In a severe case, the body appears to have only skin and bones with wrinkling of the skin, the head looks proportionately large, and the ribs are markedly visible (Table 5.2). Usually the child is irritable. Marasmus occurs as a result of severe deficiency of energy, protein, vitamins and minerals, although the primary cause is inadequate energy intake. This deficiency often results when there is a decrease or absence of breastfeeding, feeding diluted milk formula or delay in introducing solid foods in the diet. In marasmus, the body generally adapts itself to the deficiency of energy and protein. The muscles provide amino acids leading to the production of adequate amounts of proteins including albumin and beta-lipoprotein. Adequate amounts of albumin and beta-lipoprotein prevent the development of oedema and fatty enlargement of the liver in marasmus.

Kwashiorkor, which occurs mostly in children 1–3 years of age, results from a deficiency of dietary protein and is usually associated with an infection. However, Gopalan in India did not find any difference in diets of children developing marasmus or kwashiorkor. He emphasised that the two conditions are interconvertible and the outcome is determined not by the diet but by the child's response. Marasmus according to C Gopalan is an adapted state and

**Table 5.2:** Differences between marasmus and kwashiorkor

<i>Factors</i>	<i>Marasmus</i>	<i>Kwashiorkor</i>
Age	1st year	2nd and 3rd years
Weight-for-age	< 60%	60–80%
Oedema	–	+
Skin changes	Less common	Common
Hair changes	Rare	Common
Mental changes	Uncommon (irritability)	Common (loss of interest)
Face	Monkey like	Moon face
Muscle wasting	+++	+
Enlarged liver	+/-	+
Adaptation	Good	Poor
Appetite	Usually good	Poor



kwashiorkor occurs when there is dysadaptation. Typically there are skin lesions (pigmented or depigmented areas with or without ulceration), scanty lustreless hair, an enlarged fatty liver, loss of interest in the surroundings, and loss of appetite. The oedema is usually noticed in the feet but can also occur in other parts of the body. There is a decrease in blood albumin level, which is partly responsible for development of oedema. Beta-lipoprotein is not produced in adequate amounts, resulting in impaired transport of fat and an enlarged fatty liver.

The child with marasmic kwashiorkor has clinical findings of both marasmus and kwashiorkor. The child has oedema, a WA less than 60%, gross wasting and is usually stunted. There may be mild hair and skin changes and an enlarged, fatty liver.

A new term, severe acute malnutrition (SAM), is now used to describe the acutely malnourished children (WHO). A child is said to have SAM if any of the following is present:

- WH is less than 70% or less than  $-3 Z$
- Bipedal oedema
- Mid upper arm circumference (MUAC) less than 11 cm (for children between the ages of 1 and 5 years).

### MANAGEMENT OF MILD OR MODERATE MALNUTRITION

Mild and moderately malnourished (underweight or stunted) children account for the major burden of malnutrition in any developing country. Management of these children is, therefore, very important from a public health perspective. These children are managed at the household and community levels. The focus is on counselling of parents on health and nutrition education, care during common illnesses including diarrhoea, micronutrient supplementation, and in many countries periodic deworming. A commonly used strategy in developing countries is growth monitoring and promotion (GMP) where under-five children are weighed at regular intervals and a package of interventions provided at the contacts. Potential strengths of GMP are that it provides frequent contact with health workers and a platform for child health interventions. However, the success of GMP depends on how sincerely the programme is carried out.

### FACILITY-BASED MANAGEMENT OF SEVERE ACUTE MALNUTRITION

According to the World Health Organisation, a death rate of greater than 20% is unacceptable in the management of severely malnourished children, 11–20% is poor, 5–10% is moderate, 1–4% is good and less than 1% is excellent. The reason for the high death rates among severely malnourished children is believed to be faulty case management.

Appropriate feeding, micronutrient supplementation, broad-spectrum antibiotic therapy and judicious use of rehydration fluids (particularly intravenous fluids) are factors that can reduce death, morbidity and cost of treatment of these children. A severely malnourished child having any of the following features should be admitted to a nutrition unit having appropriate facilities and trained staff or referred to a hospital. But these criteria are flexible and may be modified according to local conditions, such as availability of trained staff and facilities. Criteria for referral of a child with SAM to a hospital include:

- Signs of circulatory collapse—cold hands and feet, weak radial pulse, not alert (may be due to severe dehydration or septic shock)
- Convulsion/unconsciousness
- Cyanosis of lips, tongue or finger tips
- Inability to drink
- Chest indrawing
- Fast breathing (60 breaths/min or more in an infant < 2 months, > 50/min in a child 2 months to 1 year, > 40/min in a child 1–5 years old)
- Wheezy breathing
- Hypothermia (body temperature < 35.5°C)
- High fever (> 39.0°C)
- Very severe pallor or anaemia (haemoglobin < 5 g/dl)
- Persistent diarrhoea (diarrhoea for > 14 days)
- Persistent vomiting (> 3 episodes per hour)
- Bloody mucoid stools
- Loss of appetite
- Severe vitamin A deficiency (VAD) or keratomalacia
- Jaundice
- Purpura
- Distended, tender abdomen
- Age less than 1 year.

### Evaluation of the Severely Malnourished Child

If the child with SAM is acutely ill and requires immediate treatment, details of the history and physical examination should be delayed. History-taking should include the following:

- Usual diet given before the present illness
- History of breastfeeding
- Food and fluids taken in the past few days
- Duration, frequency and nature of diarrhoea or vomiting
- Time when urine was last passed
- Recent sinking of the eyes
- Duration and nature of cough
- History of fever
- Contact with measles or tuberculosis
- Major past illness
- Any deaths of siblings

- Milestones reached (sitting, standing, etc.)
- Immunisations
- Socioeconomic history.

A thorough physical examination should be done, that includes:

- Temperature (for diagnosing fever and hypothermia)
- Respiratory rate and type of respiration (for diagnosing pneumonia and heart failure)
- Signs of circulatory collapse (cold hands and feet, weak/absent radial pulse, not alert)
- Weight and height or length. Length is measured for children aged less than 2 years, less than 85 cm tall or those who cannot stand
- Hydration status
- Pallor
- Oedema
- Abdominal distension and bowel sounds
- Enlarged or tender liver, jaundice
- Vitamin A deficiency signs in eyes
- Pus in eyes
- Signs of infection in mouth, throat and ears
- Signs of infection in and around the genital organs
- Appearance of stools (consistency, presence of blood, mucus or worms).

### Laboratory Investigations

Laboratory tests are not essential for management. The following tests should be done if facilities are available:

- Blood glucose if the child is not alert
- Haemoglobin if the child is severely pale
- Urine for pus cells if urinary tract infection is suspected
- X-ray chest if severe pneumonia or if tuberculosis (TB) is suspected
- Mantoux test if TB is suspected (an induration of  $> 5$  mm indicates a positive test in a severely malnourished child).

### Reductive Adaptation in Severe Acute Malnutrition

Children with SAM undergo physiological and metabolic changes to conserve energy and preserve essential processes. This is known as reductive adaptation. If these changes are ignored during treatment, hypoglycaemia, hypothermia, heart failure, untreated infection can cause death. This can be illustrated by the reasons for not giving iron during the initial acute phase treatment of SAM. The child with SAM makes less haemoglobin than usual. Giving iron early in treatment leads to 'free iron' that can cause problems:

- Free iron is highly reactive and promotes formation of free radicals which can damage cell membranes
- Promotes bacterial growth and can make infections worse

- The body tries to convert it into ferritin, the storage form of iron. This uses up essential energy and amino acids. Therefore, iron should not be given during the acute phase of management of SAM.

### PHASES OF MANAGEMENT OF SEVERE ACUTE MALNUTRITION

The management of children with severe malnutrition can be divided into three phases.

#### Acute Phase

Problems that endanger life, such as hypoglycaemia (a low blood glucose level) or an infection, are identified and treated. Feeding and correction of micronutrient deficiencies are initiated during this phase. Broad-spectrum antibiotics are started. Small, frequent feeds are given (about 100 kcal/kg and 1–1.5 g protein/kg per day). The main objective of this phase is to stabilise the child. Case fatality is highest during this phase of management, the principal causes being hypoglycaemia, hypothermia, infection and water-electrolyte imbalance. Most deaths occur within the first 1–2 days of admission. This phase usually takes about 4–5 days.

#### Nutritional Rehabilitation Phase

The aim of this phase is to recover lost weight by intensive feeding. The child is stimulated emotionally and physically, and the mother is trained to continue care at home. Around 150–250 kcal/kg and 3–5 g protein/kg are provided daily during this phase. Micronutrients, including iron, are continued. Treatment remains incomplete without health and nutrition education of the mothers. This phase takes 2–4 weeks if the criterion of discharge is WHZ  $-2$  without oedema.

#### Follow-up

Follow-up is done to prevent relapse of severe malnutrition, and to ensure proper physical growth and mental development of the child. The likelihood of relapse into severe malnutrition is more within 1 month of discharge. Follow-up visits should be fortnightly initially and then monthly until the child has achieved WHZ greater than  $-1$ . Nutritional status and general condition are assessed and the caregivers counselled. Commonly occurring illnesses are treated and health and nutrition education for the caregivers reinforced.

These phases of management can be carried out through the ten steps of treatment:

#### Step 1: Treat/Prevent Hypoglycaemia

Hypoglycaemia and hypothermia usually occur together and are signs of infection. The child should be tested

for hypoglycaemia on admission or whenever lethargy, convulsions or hypothermia are found. If blood glucose cannot be measured, all children with SAM should be assumed to be hypoglycaemic and treated accordingly.

If the child is conscious and blood glucose is less than 3 mmol/L or 54 mg/dl give:

- 50 ml bolus of 10% glucose or 10% sucrose solution (5 g or 1 rounded teaspoon of sugar in 50 ml or 3.5 tablespoons water), orally or by nasogastric (NG) tube. Then feed starter diet F-75 (discussed in Step 7) every 30 minutes for 2 hours (giving one quarter of the 2 hourly feed each time).
- Two hourly feeds, day and night for first 24–48 hours (discussed in Step 7).

If the child is unconscious, lethargic or convulsing give:

- IV sterile 10% glucose (5 ml/kg) or 25% glucose (2 ml/kg), followed by 50 ml of 10% glucose or sucrose by NG tube.
- Then give starter F-75 as above.

### Step 2: Treat/Prevent Hypothermia

If the axillary temperature is less than 35.0°C or the rectal temperature is less than 35.5°C:

- Start feeding right away (or start rehydration if needed)
- Rewarm the child by clothing (including head), covering with a warm blanket or placing the child on the mother's bare chest (skin-to-skin) and covering them. A heater or lamp may be placed nearby. During rewarming rectal temperature should be taken 2 hourly until it rises to greater than 36.5°C (half hourly if heater is used). The child must be kept dry and away from draughts of wind.

### Step 3: Treat/Prevent Dehydration

The WHO-ORS (75 mmol sodium/L) contains too much sodium and too little potassium for severely malnourished children. They should be given the special rehydration solution for malnutrition (ReSoMal) (Table 5.3). It is difficult to estimate dehydration status in a severely malnourished child. All children with watery diarrhoea should be assumed to have dehydration and given:

- Every 30 minutes for first 2 hours, ReSoMal 5 ml/kg body weight orally or by NG tube, then
- Alternate hours for up to 10 hours, ReSoMal 5–10 ml/kg per hour (the amount to be given should be determined by how much the child wants, and stool loss and vomiting). F-75 is given in alternate hours during this period until the child is rehydrated.
- After rehydration, continue feeding F-75 (discussed in Step 7).

If diarrhoea is severe then WHO-ORS (75 mmol sodium/L) may be used because loss of sodium in stool

is high, and symptomatic hyponatraemia can occur with ReSoMal. Severe diarrhoea can be due to cholera or rotavirus infection, and is usually defined as stool output greater than 5 ml/kg per hour.

Return of tears, moist mouth, eyes and fontanelle appearing less sunken, and improved skin turgor, are signs that rehydration is proceeding. It should be noted that many severely malnourished children would not show these changes even when fully rehydrated. Continuing rapid breathing and pulse during rehydration suggest coexisting infection or overhydration. Signs of excess fluid (overhydration) are increasing respiratory rate and pulse rate, increasing oedema and puffy eyelids. If these signs occur, fluids are stopped immediately and the child reassessed after 1 hour. Intravenous rehydration should be used only in case of shock, infusing slowly to avoid overloading the heart.

### Step 4: Correct Electrolyte Imbalance

All severely malnourished children have excess body sodium even though serum sodium may be low. Deficiencies of potassium and magnesium are also present and may take at least 2 weeks to correct. Oedema is partly due to these imbalances and must never be treated with a diuretic, give:

- Extra potassium 3–4 mmol/kg per day
- Extra magnesium 0.4–0.6 mmol/kg per day
- When rehydrating, give low sodium rehydration fluid (e.g. ReSoMal)
- Prepare food without salt.

The extra potassium and magnesium can be prepared in a liquid form and added directly to feed during preparation (Table 5.3 for a recipe for a combined electrolyte/mineral solution).

### Step 5: Treat/Prevent Infection

In severe malnutrition the usual signs of infection, such as fever, are often absent, and infections often hidden. Therefore, give routinely on admission:

- Broad-spectrum antibiotics
- Measles vaccine if child is greater than 6 months and not immunised (delay if the child is in shock)

If the child appears to have no complications give:

- Oral amoxicillin 15 mg/kg 8 hourly for 5 days.

If the child is sick looking or lethargic or has complications (hypoglycaemia, hypothermia, skin lesions, respiratory tract or urinary tract infection) give:

- Ampicillin 50 mg/kg IM/IV 6 hourly for 2 days, then oral amoxicillin 15 mg/kg 8 hourly for 5 days
- Gentamicin 7.5 mg/kg IM/IV once daily for 7 days.

If the child fails to improve clinically by 48 hours or deteriorates after 24 hours, a third-generation cephalosporin,

**Table 5.3:** Rehydration solution for malnutrition

<i>Ingredient</i>	<i>Amount</i>	
<b>Recipe for ReSoMal</b>		
Water (boiled and cooled)	2 L	
WHO-ORS	1 L sachet	
Sugar	50 g	
Electrolyte/mineral solution (discussed below)	40 ml	
ReSoMal contains approximately Na less than 45 mmol/L, K 40 mmol/L and Mg 3 mmol/L.		
<b>Recipe for electrolyte/mineral solution</b>		
Weigh the following ingredients and make up to 2,500 ml. Add 20 ml of electrolyte/mineral solution to 1,000 ml of milk feed.		
	<i>g</i>	<i>Molar content of 20 ml</i>
Potassium chloride	224	24 mmol
Tripotassium citrate	81	2 mmol
Magnesium chloride	76	3 mmol
Zinc acetate	8.2	300 mmol
Copper sulphate	1.4	45 mmol
Water up to	2,500 ml	

*Note:* Add selenium if available and the small amounts can be measured locally (sodium selenate 0.028 g) and iodine (potassium iodide 0.012 g) per 2,500 ml.

*Preparation:* Dissolve the ingredients in cooled boiled water. Store the solution in sterilised bottles in the refrigerator to retard deterioration. Make fresh each month and discard if it turns cloudy. If the preparation of this electrolyte/mineral solution is not possible and if premixed sachets are not available, give K, Mg and Zn separately.

#### *Potassium*

- Make a 10% stock solution of potassium chloride (KCl), 100 g in 1 litre of water
- For oral rehydration solution, use 45 ml of stock KCl solution instead of 40 ml electrolyte/mineral solution
- For milk feeds, add 22.5 ml of stock KCl solution instead of 20 ml of the electrolyte/mineral solution.

#### *Magnesium*

- Give sterile magnesium sulphate (50% w/v) intramuscularly once daily (0.1 ml/kg up to a maximum of 2 ml) for 7 days.

#### *Zinc*

- Prepare a 1.5% solution of zinc acetate (15 g zinc acetate in 1 litre of water). Give the zinc acetate solution orally, 1 ml/kg per day.

e.g. ceftriaxone 50–75 mg/kg per day IV or IM once daily may be started with gentamicin. Ceftriaxone, if available, should be the preferred antibiotic in case of septic shock or meningitis. Where specific infections are identified, add:

- Specific antibiotics if appropriate
- Antimalarial treatment if the child has a positive blood film for malaria parasites.

If anorexia still persists, reassess the child fully, checking for sites of infection and potentially resistant organisms, and ensure that vitamin and mineral supplements have been correctly given.

### **Step 6: Correct Micronutrient Deficiencies**

All severely malnourished children have vitamin and mineral deficiencies. Although anaemia is common, do not give iron initially but wait until the child has a good appetite and starts gaining weight (usually by the 2nd week), as giving iron can make infections worse, give:

- Vitamin A orally on day 1 (for age > 12 months, give 200,000 International Unit (IU); for age 6–12 months, give 100,000 IU; for age 0–5 months, give 50,000 IU) unless there is definite evidence that a dose has been given in the last month. If the child has xerophthalmia, the same doses of vitamin A are repeated on days 2 and 14 or on day of discharge.

Give daily for the entire period of nutritional rehabilitation (at least 4 weeks):

- Multivitamin supplements
- Folic acid 1 mg/day (5 mg on day 1)
- Zinc 2 mg/kg per day
- Copper 0.3 mg/kg per day
- Iron 3 mg/kg per day but only when gaining weight (start after the stabilisation phase is over).

A combined electrolyte/mineral/vitamin (CMV) mix for severe malnutrition is available commercially. This can

replace the electrolyte/mineral solution and multivitamin and folic acid supplements mentioned in Steps 4 and 6, but still give the large single dose of vitamin A and folic acid on day 1, and iron daily after weight gain has started.

### Step 7: Start Cautious Feeding

During the stabilisation phase a cautious approach is required due to the child's fragile physiological state and reduced capacity to handle large feeds. Feeding should be started as soon as possible after admission. WHO-recommended starter formula, F-75, contains 75 kcal/100 ml and 0.9 g protein/100 ml (Table 5.4). Very weak children may be fed by spoon, dropper or syringe. Breastfeeding is encouraged between the feeds of F-75. A recommended schedule in which volume is gradually increased, and feeding frequency gradually decreased is:

Days	Frequency	Vol/kg per feed	Vol/kg per day
1–2	2 hourly	11 ml	130 ml
3–5	3 hourly	16 ml	130 ml
6–7+	4 hourly	22 ml	130 ml

If intake does not reach 80 kcal/kg per day despite frequent feeds, coaxing and reoffering, give the remaining feed by NG tube.

Criteria for increasing volume/decreasing frequency of F-75 feeds:

- If vomiting, lots of diarrhoea or poor appetite, continue 2 hourly feeds
- If little or no vomiting, modest diarrhoea (less than 5 watery stools per day), and finishing most feeds, change to 3 hourly feeds
- After a day on 3 hourly feeds—if no vomiting, less diarrhoea and finishing most feeds, change to 4 hourly feeds.

In case of SAM infants less than 6 months old, feeding should be initiated with F-75. During the nutritional rehabilitation phase, F-75 can be continued and if possible relactation should be done.

### Step 8: Achieve Catch-up Growth

During the nutritional rehabilitation phase feeding is gradually increased to achieve a rapid weight gain of greater than 10 g gain/kg per day. The recommended milk-based F-100 contains 100 kcal and 2.9 g protein/100 ml (Table 5.4). Modified porridges or modified family foods can be used provided they have comparable energy and protein concentrations.

Readiness to enter the rehabilitation phase is signalled by a return of appetite, usually about one week after admission. A gradual transition is recommended to avoid the risk of

heart failure, which can occur if children suddenly consume huge amounts.

To change from starter to catch-up formula:

- Replace F-75 with the same amount of catch-up formula F-100 every 4 hours for 48 hours then
- Increase each successive feed by 10 ml until some feed remains uneaten. The point when some remains unconsumed after most feeds is likely to occur when intakes reach about 30 ml/kg per feed (200 ml/kg per day).

If weight gain is:

- Poor (5 g/kg per day), the child requires full reassessment for other underlying illnesses, e.g. TB
- Moderate (5–10 g/kg per day), check whether intake targets are being met, or if infection has been overlooked
- Good (> 10 g/kg per day), continue to praise staff and mothers.

### Step 9: Provide Sensory Stimulation and Emotional Support

In severe malnutrition, there is delayed mental and behavioural development. Just giving diets will improve physical growth but mental development will remain impaired. This is improved by providing tender loving care and a cheerful, stimulating environment. The play sessions should make use of toys made of discarded material.

### Step 10: Prepare for Follow-up After Recovery

A child who has achieved WHZ  $-2$  SD can be considered to have improved. At this point, the child is still likely to have a low WA due to stunting. Good feeding practices and sensory stimulation should be continued at home. Parents or caregivers should be counselled on:

- Feeding energy and nutrient-dense foods
- Providing structured plays to the children
- To bring the child back for regular follow-up checks
- Ensure that booster immunisations are given
- Ensure that vitamin A and antihelminthic drugs are given every 6 months.

## TREATMENT OF COMPLICATIONS

### Shock in Severely Malnourished Children

Shock may be due to severe dehydration or sepsis, which can coexist and difficult to distinguish from one another. Children with dehydration will respond to IV fluids while those with septic shock and no dehydration may not. Emergency treatment is started with:

- Oxygen inhalation
- Sterile 10% glucose (5 ml/kg) IV

Table 5.4: Recipes for F-75 and F-100

<i>If you have cereal flour and cooking facilities, use one of the top three recipes for F-75:</i>			
<i>Alternatives</i>	<i>Ingredient</i>	<i>Amount for F-75</i>	
If you have dried skimmed milk	Dried skimmed milk	25 g	
	Sugar	70 g	
	Cereal flour	35 g	
	Vegetable oil	30 g	
	Mineral mix*	20 ml	
	Water to make 1,000 ml	1,000 ml**	
	Dried whole milk	35 g	
If you have dried whole milk	Sugar	70 g	
	Cereal flour	35 g	
	Vegetable oil	20 g	
	Mineral mix*	20 ml	
	Water to make 1,000 ml	1,000 ml**	
If you have fresh cow's milk or full-cream (whole) long life milk	Fresh cow's milk, or full-cream (whole) long life milk	300 ml	
	Sugar	70 g	
	Cereal flour	35 g	
If you have fresh cow's milk or full-cream (whole) long life milk	Vegetable oil	20 g	
	Mineral mix*	20 ml	
	Water to make 1,000 ml	1,000 ml**	
<i>If you do not have cereal flour, or there are no cooking facilities, use one of the following recipes No cooking is required for F-100 for F-75:</i>			
<i>Alternatives</i>	<i>Ingredient</i>	<i>Amount for F-75</i>	<i>Amount for F-100</i>
If you have dried skimmed milk	Dried skimmed milk	25 g	80 g
	Sugar	100 g	50 g
	Vegetable oil	30 g	60 g
	Mineral mix*	20 ml	20 ml
	Water to make 1,000 ml	1,000 ml**	1,000 ml**
If you have dried whole milk	Dried whole milk	35 g	110 g
	Sugar	100 g	50 g
	Vegetable oil	20 g	30 g
	Mineral mix*	20 ml	20 ml
	Water to make 1,000 ml	1,000 ml**	1,000 ml**
If you have fresh cow's milk or full-cream (whole) long life milk	Fresh cow's milk or full-cream (whole) long life milk	300 ml	880 ml
	Sugar	100 g	75 g
	Vegetable oil	20 g	20 g
	Mineral mix*	20 ml	20 ml
	Water to make 1,000 ml	1,000 ml**	1,000 ml**

\* The optimal interval between doses is four to six months. A dose should not be given too soon after previous dose of vitamin A supplement: the minimum recommended interval between doses for the prevention of vitamin A deficiency is one month (the interval can be reduced in order to treat clinical vitamin A deficiency and measles cases).

\*\* Important note about adding water: Add just the amount of water needed to make 1,000 ml of formula (This amount will vary from recipe to recipe, depending on the other ingredients). Do not simply add 1,000 ml of water, as this will make the formula too dilute. A mark for 1,000 ml should be made on the mixing container for the formula, so that water can be added to the other ingredients up to this mark



## Nutrition

- Infusion of an isotonic fluid at 15 ml/kg over 1 hour
- Measure and record pulse and respiration rates every 10 minutes
- Give broad-spectrum antibiotics (discussed in Step 5).

If there are signs of improvement (pulse and respiration rates fall):

- Repeat infusion 15 ml/kg over 1 hour; then
- Switch to oral or NG rehydration with ReSoMal, 10 ml/kg per hour in alternate hours up to 10 hours; give ReSoMal in alternate hours with starter F-75, then continue feeding with starter F-75.

If the child fails to improve (pulse and respiration rates fall) after the first hour of treatment with an infusion 15 ml/kg, assume that the child has septic shock. In this case:

- Give maintenance IV fluids (3 ml/kg per hour) while waiting for blood
- When blood is available transfuse fresh whole blood at 10 ml/kg slowly over 3 hours.

### Very Severe Anaemia in Malnourished Children

A blood transfusion is required if:

- Hb is less than 4 g/dl or packed cell volume less than 12%
- Or if there is respiratory distress and Hb is between 4 g/dl and 6 g/dl.

The child is given whole blood 10 ml/kg body weight slowly over 3 hours and furosemide 1 mg/kg IV at the start of the transfusion. If the severely anaemic child has signs of cardiac failure, transfuse packed cells (5–7 ml/kg) rather than whole blood.

In all cases of anaemia, oral iron (elemental iron 3 mg/kg per day) should be given for 2 months to replenish iron stores. This should not be started until the child has begun to gain weight.

### Vitamin A Deficiency

If the child shows any eye signs of deficiency, give orally:

- Vitamin A on days 1, 2 and 14 (for age >12 months, give 200,000 IU; for age 6–12 months, give 100,000 IU; for age 0–5 months, give 50,000 IU).

If there is corneal clouding or ulceration, give additional eye care to prevent extrusion of the lens:

- Instil chloramphenicol or tetracycline eye drops (1%) 2–3 hourly as for 7–10 days in the affected eye
- Instil atropine eye drops (1%), 1 drop three times daily for 3–5 days
- Cover with eye pads soaked in saline solution and bandage.

Children with VAD are likely to be photophobic and keep their eyes closed. It is important to examine the eyes very gently to prevent damage and rupture.

### Dermatosis

Weeping skin lesions are commonly seen in and around the buttocks of children with kwashiorkor. Affected areas should be bathed in 1% potassium permanganate solution for 15 minutes daily. This dries the lesions, helps to prevent loss of serum and inhibits infection.

### Parasitic Worms

- Give albendazole 400 mg orally, single dose (if > 2 years old)
- Give albendazole 200 mg orally, single dose (if 1–2 years old).

This treatment should be given only during the nutritional rehabilitation phase.

### Lactose Intolerance

Most children with SAM and diarrhoea respond to the initial management. Diarrhoea due to lactose intolerance in SAM is not common. In exceptional cases, milk feeds may be substituted with yoghurt or a lactose-free formula.

Osmotic diarrhoea may be suspected if diarrhoea worsens substantially in young children who are given F-75 prepared with milk powder (this preparation has slightly higher osmolarity). In such a situation, use F-75 prepared with cereal powder may be helpful.

### Tuberculosis

If TB is strongly suspected (contact with adult TB patient, poor growth despite good intake, chronic cough, chest infection not responding to conventional antibiotics):

- Perform Mantoux test (false-negatives are frequent in severe malnutrition)
- Chest X-ray if possible.

If test is positive or there is a strong suspicion of TB, treat according to national TB guidelines.

## COMMUNITY-BASED MANAGEMENT OF SEVERE ACUTE MALNUTRITION

In countries with a heavy burden of SAM, facilities and resources for taking care of such children are far from being adequate. It is now agreed that children with SAM who have good appetite but no complications can be treated at the community level. Because the number of facilities is always suboptimal in developing countries, facility-based treatment cannot cater to the huge numbers of severely malnourished children living in the community. Moreover, feeding therapeutic diets including F-75 and F-100 at home is not recommended due to the propensity of these liquid diets to become contaminated in the home environment. To overcome this problem, ready-to-use-therapeutic food (RUTF) has

been developed and used in field situations. It is now being used in emergency relief programmes. If prepared as per prescription, RUTF has the nutrient composition of F-100 but is more energy dense and does not contain any water. Bacterial contamination, therefore, does not occur and the food is safe for use also in home conditions. The prototype RUTF is made of peanut paste, milk powder, vegetable oil, mineral and vitamin mix as per WHO recommendations. It is available, as a paste in a sachet, does not require any cooking and children can eat directly from the sachet. Local production of RUTF has commenced recently and several studies have concluded that local RUTF is as good as the prototype RUTF.

RUTF seems to play an important role in the management of severe malnutrition in disaster and emergency settings. A supplementary feeding programme providing food rations to families of the affected child should be in place. So should be a stabilisation centre for taking care of acutely ill severely malnourished children who need facility-based care based on WHO guidelines. For countries in Asia including India, Bangladesh and Pakistan, which have the highest burden of child malnutrition, there is a need for research on cost-effectiveness and sustainability of management of severe malnutrition using RUTF.

### Micronutrient Deficiencies in Childhood

Micronutrients represent specific nutrients that impact on health and nutrition outcomes when consumed in small quantities. These micronutrients represent essential ingredients necessary for homeostasis and are affected by a variety of factors including maternal nutrition status, dietary intake, existing morbidity and body losses (Fig. 5.2).

Of various micronutrient deficiencies of relevance to children, VAD, iron and zinc deficiency represent the few for which there is considerable body of evidence for adverse outcomes and intervention strategies.

### Vitamin A Deficiency in Childhood

Vitamin A is essential for the functioning of the immune system and the healthy growth and development of children. VAD is a public health problem in more than half of all countries, especially in Africa and South-East Asia, hitting hardest young children and pregnant women in low-income countries. VAD is the leading cause of preventable blindness in children and increases the risk of disease and death from severe infections. Globally, it is estimated that 140–250 million children under-five years of age are affected by VAD. These children suffer a dramatically increased risk of death, blindness and illness, especially from measles and diarrhoea. While severe ocular manifestations of VAD such as Bitot's spots, xerophthalmia and keratomalacia are fortunately rare,

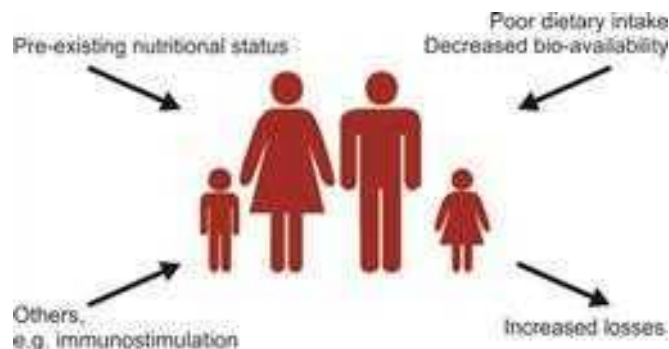


Fig. 5.2: Determinants of micronutrient status

subclinical deficiency of vitamin A is relatively common in poor communities.

For pregnant women in high-risk areas, VAD occurs especially during the last trimester when demand by both the unborn child and the mother is highest. The mother's deficiency is demonstrated by the high prevalence of night blindness during this period. In pregnant women VAD causes night blindness and may increase the risk of maternal mortality.

Vitamin A is also regarded as crucial micronutrient for maternal and child survival and it has been shown that supplying adequate vitamin A in high-risk areas can significantly reduce mortality. Conversely, its absence causes a needlessly high-risk of disease and death. Based on these findings a number of preventive and therapeutic strategies are in place for the prevention and treatment of vitamin A deficiencies.

### Preventive and Therapeutic Strategies

Vitamin A is a crucial component for health throughout the life cycle. In areas with high rates of maternal malnutrition and vitamin A, adequate supply of maternal vitamin A (as well as other nutrients) in pregnancy is a fundamental measure. Since breast milk is a natural source of vitamin A, promoting breastfeeding is the best way to protect babies from VAD.

For deficient children, the periodic supply of high-dose vitamin A in swift, simple, low-cost, high-benefit interventions has also produced remarkable results. It is estimated that this has the potential of reducing child mortality by 23% overall and by up to 50% for those with measles infection.

These measures must be supplemented with measures to promote adequate feeding and dietary diversification. For vulnerable rural families, for instance in Africa and South-East Asia, growing fruits and vegetables in home gardens complements dietary diversification and fortification and contributes to better lifelong health. Where this may be difficult, food fortification is a cost-effective measure



for providing daily minimal needs for vitamin A. Food fortification, for example, sugar in Guatemala, has been shown to adequately maintain population level vitamin A status, especially for high-risk groups and needy families.

Combining the administration of vitamin A supplements with immunisation is an important part of this effort. Since 1987, WHO has advocated the routine administration of vitamin A with measles vaccine in countries where VAD is a problem. Great success and many millions of children have been reached by including vitamin A with National Immunisation Days (NIDs) to eradicate polio. High-dose vitamin A should be avoided during pregnancy due to the theoretical risk of teratogenesis (birth defects). From a programmatic perspective, high-dose vitamin A supplementation must occur during the safe infertile period immediately after delivery. Accordingly, high-dose vitamin A supplementation can be provided safely to all postpartum mothers within 6 weeks of delivery, when the chance of pregnancy is remote. For breastfeeding mothers, the safe infertile period extends up to 8 weeks after delivery. The first contact with the infant immunisation services provides an excellent opportunity to supplement postpartum mothers and improve the vitamin A content of their breast milk.

Provision of vitamin A supplements every 4–6 months is an inexpensive, quick and effective way to improve vitamin A status and save children's lives. The Beaton Report concluded that all-cause mortality among children aged 6–59 months was reduced by 23% through vitamin A supplementation in areas where VAD was a public health problem. However, comprehensive control of VAD must include dietary improvement and food fortification in the long-term.

Immunisation contacts offer unrivalled opportunities for delivering vitamin A to children who suffer from deficiency.

Studies show that vitamin A does not have any negative effect on seroconversion of childhood vaccines. As well as routine immunisation services, NIDs for polio eradication, measles and multiantigen campaigns have been used safely and successfully to provide vitamin A to a wide age range of children at risk.

There is a well-established scientific basis for the treatment of measles cases with vitamin A supplementation that is recommended by WHO as part of the integrated management of childhood illness. The recommended doses of vitamin A supplementation for the prevention of VAD are indicated in the Table 5.5.

### Iron Deficiency in Childhood

Iron is an important dietary mineral that is involved in various bodily functions, including the transport of oxygen in the blood, essential in providing energy for daily life. Iron is also vital for brain development. Infants, toddlers, preschoolers and teenagers are at high-risk of iron deficiency, mainly because their increased needs for iron may not be met by their diets. Without intervention, a child whose dietary intake is inadequate in providing enough iron or has excessive losses through the intestine, e.g. with hookworm infestation, will eventually develop iron deficiency (Table 5.6).

### Causes of Iron Deficiency in Children

Major risk factors for the development of iron deficiency in children include:

1. Prematurity and low birth weight (LBW)
2. Exclusive breastfeeding beyond 6 months
3. Introduction of cow's milk as the main drink before 12 months
4. High intake of cow's milk

**Table 5.5:** Strategies for vitamin A supplementation with immunisations

Potential target groups and immunisation contacts in countries with vitamin A deficiency

<i>Target group</i>	<i>Immunisation contact</i>	<i>Vitamin A dose</i>
All mothers irrespective of their mode of infant feeding up to 6 weeks postpartum if they have not received vitamin A supplementation after delivery	BCG, OPV-0 or DTP-1 contact up to 6 weeks	200,000 IU
Infants aged 9–11 months	Measles vaccine contact	100,000 IU
Children aged 12 months and older		200,000 IU
Children aged 1–4 years	Booster doses* Special campaigns* Delayed primary immunisation doses*	200,000 IU

\* The optimal interval between doses is 4–6 months. A dose should not be given too soon after a previous dose of vitamin A supplement: the minimum recommended interval between doses for the prevention of vitamin A deficiency is one month (the interval can be reduced in order to treat clinical vitamin A deficiency and measles cases)

**Table 5.6:** Iron requirements and recommended iron intakes by age and gender group

Groups	Age (years)	Mean body weight (kg)	Required iron intake for growth (mg/day)	Median iron losses (mg/day)	
				Basal	Menstrual
Children	0.5–1	9.0	0.55	0.17	
	1–3	13.3	0.27	0.19	
	4–6	19.2	0.23	0.27	
	7–10	28.1	0.32	0.39	
Adolescent boys	11–14	44.0	0.55	0.62	
	15–17	65.4	0.60	0.90	
	18 +	75.0		1.05	
Adolescent girls	11–14*	46.1	0.55	0.65	
	11–14	46.1	0.55	0.65	0.48
	15–17	56.4	0.35	0.79	0.48
	18 +	62.0		0.87	0.48

\*Non-menstruating

- Low or no meat intake and poor quality diet in the 2nd year of life
- Possible gastrointestinal diseases including coeliac disease and persistent diarrhoea.

Infants, children and teenagers greatly increase their iron requirements during the period of rapid growth spurts, which also increase their need for iron.

### Signs and Symptoms

The signs and symptoms of iron deficiency anaemia in children can include:

- Behavioural problems
- Recurrent infections
- Loss of appetite
- Lethargy
- Breathlessness
- Increased sweating
- Strange 'food' cravings (pica) like eating dirt
- Failure to grow at the expected rate.

### Preventive and Therapeutic Strategies

Suggestions to prevent or treat iron deficiency in babies less than 12 months of age include the following measures:

- Eating an iron-rich diet during pregnancy. Red meat is the best source of iron.
- Regular use of iron folate supplements in pregnancy to ensure adequate iron stores.
- Delayed cord clamping at birth, especially in preterm infants to ensure adequate transplacental transfer of blood and iron supplies.
- Exclusive breastfeeding for the first 6 months with the possible introduction of iron drops in preterm or LBW infants by 3–4 months of age.

- Avoidance of cow's milk or other fluids that may displace iron-rich solid foods before 12 months of age.
- Timely introduction of good quality complementary foods at 6 months of age and promotion of iron and zinc containing foods (especially minced meat, liver, poultry, etc.).
- If affordable, fortified baby cereals may also be used along with pureed fruit and vegetables. Vitamin C helps the body to absorb more iron, so make sure your child has plenty of fruit and vegetables.
- In vegetarian populations, offer good sources of non-haeme iron like peas, broccoli, spinach, beans, etc.
- In populations at high-risk of nutritional anaemia, other strategies such as the use of sprinkles with microencapsulated iron may also help prevent and treat anaemia. However, care must be exercised when using iron supplements in malaria endemic areas as iron supplementation may increase morbidity and risk of hospitalisation.
- Excessive intakes of tea and coffee may interfere with iron absorption and should be avoided in children.
- Prevention and treatment of infections is an important strategy for anaemia prevention as infection is a frequent underlying cause of mild anaemia in children.

### Zinc in Child Health

Zinc is widely recognised as an essential micronutrient with a catalytic role in over a 100 specific metabolic enzymes in human metabolism. The role of zinc in human health has been recognised for almost half a century with the discovery of the syndrome of zinc deficiency, delayed sexual development and growth failure among adolescents in Iran. Zinc is one of the most ubiquitous of all trace elements involved in human

metabolism and plays multiple roles in the perpetuation of genetic material, including transcription of DNA, translation of RNA and ultimately cellular division. It is thus critical to understand the role of zinc in health and disease, especially during the vulnerable periods of growth and development.

Unlike other essential micronutrients such as iron and vitamin A, there are no conventional tissue reserves of zinc that can be released or sequestered quickly in response to variations in dietary supply. It is recognised that the equivalent of approximately one-third (~ 450 mg) of total body zinc exchanges between the blood stream and other tissues. The major source of zinc intake is through diet, with the transcellular uptake occurring in the distal duodenum and proximal jejunum, potentially facilitated by specific transporters. The intestine also serves as the major conduit for zinc elimination from the body with almost 50% of the daily zinc losses occurring in the gut. However much of the zinc that is secreted into the intestine is subsequently reabsorbed, and this process serves as an important point of regulation of zinc balance. Other routes of zinc excretion include the urine, which accounts for approximately 15% of total zinc losses, and epithelial cell desquamation, sweat, semen, hair and menstrual blood, which together account for approximately 17% of total zinc losses.

Table 5.7 indicates the average daily requirements for zinc from a variety of diets.

### Growth and Development

Given the multiple metabolic roles of zinc and the earlier reports of the clinical association of zinc deficiency, there has been considerable interest in the potential growth benefits of zinc. Although the primary mechanisms whereby zinc influences growth are uncertain, there is a large body of literature indicating that zinc depletion limits growth and development. These include several studies of zinc supplementation among LBW infants in developing countries indicating significant benefits on weight gain and some

benefit on linear growth. Subsequent trials in Bangladesh have likewise found greater weight gain among severely malnourished inpatients who received supplemental zinc (10 mg/kg per day up to a maximum of 50 mg/day) during the course of nutritional rehabilitation.

However, there have been relatively fewer reports of a positive effect of zinc supplementation on children's linear growth during recovery from severe malnutrition perhaps related to the duration of supplementation and pre-existing zinc status. A recent meta-analysis of 33 randomised intervention trials evaluating the effect of zinc supplementation on the growth of pre-pubertal children concluded that zinc supplementation produced highly significant positive responses in linear growth and weight gain (mean effect sizes of 0.30–0.35 SD units), with comparatively greater growth responses in children with low initial WA or HA Z scores.

### Effect of Zinc on Diarrhoea

Given the association and biological plausibility of the role of zinc in intestinal mucosal injury and recovery, a number of randomised controlled trials have demonstrated significant reduction in the incidence and duration of acute and persistent diarrhoea in zinc-supplemented children compared to their placebo-treated counterparts. A pooled analysis of randomised, controlled trials of zinc supplementation performed in nine low-income countries in Latin America and the Caribbean, South and Southeast Asia and the Western Pacific, demonstrated that supplemental zinc led to an 18% reduction in the incidence of diarrhoea and a 25% reduction in the prevalence of diarrhoea. While the pooled analysis did not find differences in the effect of zinc by age, baseline serum zinc status, presence of wasting or sex, the relevance of zinc supplementation to various geographic regions of the world remained unclear. Recent studies from Africa using zinc supplementation in young children indicate significant benefit on diarrhoea burden

**Table 5.7:** Estimated average requirement (EAR) for zinc by life stage and diet type

Age	Sex	Reference body weight (kg)	Estimated average requirement for zinc (mg/day)	
			Mixed or refined vegetarian diets	Unrefined, cereal-based diets
7–12 months	M+F	9	3	4
1–3 years	M+F	12	2	2
4–8 years	M+F	21	3	4
9–13 years	M+F	38	5	7
14–18 years	M	64	8	11
14–18 years	F	56	7	9

indicating that the effect may be consistent across various geographical regions and even if zinc is administered with oral rehydration solution. Recent studies in Bangladesh of using zinc in the treatment of diarrhoea in a community setting have also demonstrated substantial reduction in concomitant use of antibiotics by healthcare providers, thus suggesting that there may be additional benefits to the use of zinc in the treatment of diarrhoea. It is also anticipated that the forthcoming World Health Assembly will also ratify a joint UNICEF-WHO statement that will strongly endorse the use of zinc supplements in young children with diarrhoea.

### Respiratory Infections

Despite advances in the recognition and management of acute respiratory infections (ARIs), these account for over 20% of all child deaths globally. In preventive trials of zinc supplementation, a significant impact has been shown on the incidence of acute lower respiratory infections. The recent pooled analysis of trials conducted in India, Jamaica, Peru and Vietnam indicated an overall 41% reduction in the incidence of pneumonia among zinc-supplemented children. More recently, the administration of zinc to children hospitalised with pneumonia in Bangladesh has been shown to reduce the severity and length of hospitalisation.

### Malaria

The benefits of zinc supplementation on the severity of disease and outcome of malaria are less straightforward. Bates et al. administered 70 mg zinc twice weekly for 18 months to children in Gambia and were able to show 32% reduction in clinic visits due to *Plasmodium falciparum* infections. Similarly a trial undertaken in Papua New Guinea among pre-school children indicated a 38% reduction in clinic visits attributable to *P. falciparum* parasitaemia as well as heavy parasitaemia. In contrast, a recent trial in Burkina Faso did not find any reduction in episodes of falciparum malaria among children who received daily supplementation with 10 mg zinc for 6 months. This variable effect of zinc in malarial areas may be related to an impact on the severity of disease rather than the incidence.

### Preventive and Therapeutic Strategies

Although there is considerable potential for zinc for improving child health in public health settings, there are few

intervention strategies to address this at scale. There is a real need for large effectiveness trials in representative settings that may help understand and develop mechanisms for the use of zinc in health systems in a replicable and sustainable manner. Presently the most effective strategies for improving zinc status are improved maternal nutrition in pregnancy, exclusive breastfeeding, dietary diversification during the weaning period and the use of zinc for the treatment of diarrhoea.

### BIBLIOGRAPHY

1. Ahmed T, Ali M, Ullah M, et al. Mortality in severely malnourished children with diarrhoea and use of a standardised management protocol. *Lancet*. 1999;353:1919-22.
2. Ahmed T, Begum B, Badiuzzaman, et al. Management of severe malnutrition and diarrhoea. *Indian Journal of Pediatrics*. 2001;68:45-51.
3. Beaton GH, Martorell R, L'Abbé, et al. Effectiveness of vitamin A supplementation in the control of young child morbidity and mortality in developing countries. UN, ACC/SCN State-of-the-art Series, Nutrition Policy Discussion Paper No. 13, 1993.
4. Bhutta ZA, Ahmed T, Black RE, et al. What works? Interventions for maternal and child undernutrition and survival. *Lancet*. 2008;371:417-40.
5. Bhutta ZA. Effect of infections and environmental factors on growth and nutritional status in developing countries. *J Pediatr Gastroenterol Nutr*. 2006;43:S13-21.
6. Bhutta ZA. The role of zinc in child health in developing countries: taking the science where it matters. *Indian Pediatr*. 2004;41:429-33.
7. Collins S. Treating severe acute malnutrition seriously. *Arch Dis Child*. 2007;92:453-61.
8. Jones G, Steketee RW, Black RE, et al. How many child deaths can we prevent this year? *Lancet*. 2003;362:65-71.
9. WHO/UNICEF/IVACG. Vitamin A supplements: a guide to their use in the treatment and prevention of vitamin A deficiency and xerophthalmia, 2nd edition. Geneva: World Health Organization; 1997.
10. World Health Organization. Management of the child with a serious infection or severe malnutrition. Guidelines for care at the first-referral level in developing countries. Geneva: World Health Organization; 2000 (WHO/FCH/CAH/00.1).
11. World Health Organization. Management of Severe Malnutrition: a Manual for Physicians and other Senior Health Workers. Geneva: World Health Organization; 1999.

## OTHER DISTURBANCES OF NUTRITION

### VITAMIN D DEFICIENCY

Rickets is a metabolic disturbance of growth, which affects bone, skeletal muscles and sometimes the nervous system. The disorder is due primarily to an insufficiency of vitamin D<sub>3</sub> (cholecalciferol), which is a naturally occurring steroid. It can be formed in the skin from 7-dehydrocholesterol by irradiation with ultraviolet (UV) light in the wavelengths 280–305 nm; or it can be ingested in the form of fish liver oils, eggs, butter, margarine and meat. The most important natural source of vitamin D is that formed from solar irradiation of the skin. UV irradiation of ergosterol produces vitamin D<sub>2</sub> (ergocalciferol), which, in humans, is a potent antirachitic substance. It is, however, not a natural animal vitamin and may have some adverse effects. Less vitamin D is made in the skin of dark-skinned people than white-skinned people.

#### Key Learning Point

➔ The term vitamin D (calciferol) is used for a range of compounds including ergocalciferol (vitamin D<sub>2</sub>), cholecalciferol (vitamin D<sub>3</sub>), dihydrotachysterol, alfacalcidol (1- $\alpha$ -hydroxycholecalciferol) and calcitriol (1,25-dihydroxycholecalciferol).

### VITAMIN D METABOLISM

Cholecalciferol (D<sub>3</sub>) is converted in the liver to 25-hydroxyvitamin D<sub>3</sub> (25-OHD<sub>3</sub>) by means of enzymatic hydroxylation in the C25 position. This metabolite circulates in the plasma with a transport protein, which migrates with the albumoglobulins. It is then 1 $\alpha$ -hydroxylated in the kidney to 1,25-dihydroxyvitamin D<sub>3</sub> (1,25(OH)<sub>2</sub>D<sub>3</sub>) by the action of 25-hydroxyvitamin D hydroxylase. Its production appears to be regulated by several factors, including the phosphate concentration in the plasma, the renal intracellular calcium and phosphate concentrations and parathyroid hormone. It acts on the cells of the gastrointestinal tract to increase calcium absorption and on bone to increase calcium resorption. In the kidney it improves the reabsorption of calcium whilst causing a phosphate diuresis. It also acts on muscle, with the ability to correct the muscle weakness often associated with rickets.

Vitamin D deficiency causes a fall in the concentration of calcium in extracellular fluid, which in turn stimulates parathormone production. The phosphate diuresis effect of a raised parathyroid hormone level results in lowering of the plasma phosphate. This produces the low calcium (Ca) x phosphate (P) product, which is such a characteristic feature of active rickets. This stage is quickly followed by an increase in the plasma alkaline phosphatase concentration and then by radiological and clinical features of rickets.

### Aetiology

Deficiency of vitamin D, which once resulted in so much infantile rickets, with its toll of permanent deformities and death during childbirth, arose principally due to the limited amount of sunshine and skyshine in northern latitudes. Furthermore, in large industrial cities the skyshine contained very little UV light after filtering through dust, smoke and fog. The need in a cold climate for heat-retaining clothing and the tendency to remain indoors in inclement weather further deprived infants of UV radiation. The natural diet of the human infant contains little vitamin D, especially if fed artificially on cow's milk. Cereals, which are commonly used, have a rachitogenic effect because the phosphorus in cereals is in an unavailable form, phytic acid (inositol hexaphosphoric acid) that combines with calcium and magnesium in the gut to form the complex compound, phytin. It is essential to fortify the infant's diet with vitamin D if rickets is to be avoided. This would not be necessary in the wholly breastfed infant living in a sunny land.

Another important causative factor, necessary for the development of rickets, is growth. The marasmic infant does not develop rickets when vitamin D deficient until re-fed and growth commences. The preterm LBW infant who grows rapidly is particularly prone to develop rickets. There is evidence that hydroxylation of vitamin D in the liver of preterm infants is impaired and this together with dietary phosphate deficiency is an important factor in the osteopaenia of preterm infants.

### Pathology

In the normal infant, there is a zone of cartilage between the diaphysis and the epiphysis, the epiphyseal plate. At the epiphyseal end this cartilage is actively growing (proliferative zone); whereas at the diaphyseal end, where mature cartilage cells are arranged in orderly columns, osteoblasts lay down calcium phosphate to form new bone. In rickets, the cartilage near the diaphysis (resting zone) shows a disordered arrangement of capillaries and although osteoblasts are numerous normal calcification does not take place. This is called osteoid tissue. In the meantime, active growth of the proliferative zone continues so that the epiphyseal plate is enlarged and swollen. Osteoid tissue instead of normal bone is also formed under the periosteum. There is also, in severe cases, a general decalcification of the skeleton so that curvatures and deformities readily develop.

The diagnosis of infantile rickets is not difficult but its rarity in developed countries has resulted in its being unfamiliar to many doctors. A careful dietary history with especial reference to the ingestion of vitamin D fortified milks and cereals and of vitamin supplements will reveal the child who is at risk. In the case of mothers with osteomalacia

from their own malnutrition, rickets has been present in their infants at birth, as the foetal requirements of 25-OHD<sub>3</sub> are obtained directly from the maternal pool. In congenital rickets the presenting feature is usually a hypocalcaemic convulsion although typical bone changes are to be expected in radiographs. Subclinical maternal and foetal vitamin D deficiency has also been found in white mothers and infants, particularly in infants born in early spring. It causes compensatory maternal hyperparathyroidism and dental enamel defects in the infant's primary dentition. Such infants are predisposed to neonatal tetany if fed on unmodified cow's milk.

There are few subjective signs of rickets. Head sweating is probably one. General muscular hypotonia encourages abdominal protuberance; this can be increased by flaring out of the rib margins and by fermentation of the excess carbohydrate so commonly included in the diets of nutritionally ignorant people. The rachitic child commonly suffers from concomitant iron deficiency anaemia. His frequent susceptibility to respiratory infections is related more to the poor environment and overcrowding rather than to the rickets. The same applies to the unhappy irritable behaviour which rachitic children sometimes exhibit.

#### Key Learning Points

- ➔ Vitamin D deficiency leads to rickets in children, which is due to undermineralisation of bone.
- ➔ There are few rich sources of vitamin D and it is unlikely that requirements of infants can be met without the use of supplements or food enrichment.
- ➔ Some infants are especially sensitive to hypercalcaemia due to vitamin D toxicity.

The objective signs of rickets are found in the skeleton. The earliest physical sign is craniotabes. This is due to softening of the occipital bones where the head rubs on the pillow. When the examiner's fingers press upon the occipital area the bone can be depressed in and out like a piece of old parchment or table tennis ball. Another common early sign is the "rachitic rosary" or "beading of the ribs" due to swelling of the costochondral junctions. The appearance is of a row of swellings, both visible and palpable, passing downwards and backwards on both sides of the thorax in the situation of the rib ends (Fig. 5.3). Swelling of the epiphyses is also seen at an early stage, especially at the wrists, knees and ankles.

In severe cases the shafts of the long bones may develop various curvatures leading to genu varum, genu valgum and coxa vara (Fig. 5.4). A particularly common deformity, shown in Figure 5.4, is curvature at the junction of the middle and lower thirds of the tibiae. This is often due to the child, who may have "gone off his feet", being sat on a chair with



**Fig. 5.3:** A 20-month-old child with rickets. Note swollen radial epiphyses, enlarged costochondral junctions, bowing of tibiae and lumbar lordosis



**Fig. 5.4:** Rickets showing genu valgum (knock knee) and genu varum (bow leg)

his feet projecting over the edge in such a fashion that their weight bends the softened tibial shafts. Bossing over the frontal and parietal bones, due to the subperiosteal deposition of osteoid, gives the child a broad square forehead or the "hot cross bun head". The anterior fontanelle may not close until

well past the age of 18 months, although this delay can also occur in hypothyroidism, hydrocephalus and even in some healthy children. Another deformity affecting the bony thorax results in Harrison's grooves. These are seen as depressions or sulci on each side of the chest running parallel to but above the diaphragmatic attachment. This sign, however, may also develop in cases of congenital heart disease, asthma and chronic respiratory infections. Laxity of the spinal ligaments can also allow the development of various spinal deformities such as dorsolumbar kyphoscoliosis. In children who have learned to stand there may be an exaggerated lumbar lordosis. The severely rachitic child will also be considerably dwarfed. Pelvic deformities are not readily appreciated in young children but in the case of girls can lead to severe difficulty during childbirth in later years. The pelvic inlet may be narrowed by forward displacement of the sacral promontory, or the outlet may be narrowed by forward movement of the lower parts of the sacrum and of the coccyx.

### Radiological Features

The normally smooth and slightly convex ends of the long bones become splayed out with the appearance of fraying or "cupping" of the edges. The distance between the diaphysis and the epiphysis is increased because the metaphysis consists largely of nonradiopaque osteoid tissue. Periosteum may be raised due to the laying down of osteoid tissue, and the shafts may appear decalcified and curved. In the worst cases, greenstick fractures with poor callus formation may occur. The earliest sign of healing is a thin line of preparatory calcification near the diaphysis (Figs 5.5A and B) followed by calcification in the osteoid just distal to the frayed ends of the diaphysis. In time both the ends and shafts of the bone usually return to normal.

### Biochemical Findings

Typical findings are a normal plasma calcium concentration (2.25–2.75 mmol/L; 9–11 mg/100 ml) whereas the plasma phosphate (normally 1.6–2.26 mmol/L; 5–7 mg/100 ml) is markedly reduced to between 0.64 and 1 mmol/L (2–3 mg/100 ml). The normal plasma calcium in the presence of diminished intestinal absorption of calcium is best explained on the basis of increased parathyroid activity, which mobilises calcium from the bones. Plasma phosphate diminishes due to the phosphaturia, which results from the effects of parathyroid hormone on the renal tubules. A plasma calcium x phosphorus product (mg per 100 ml) above 40 excludes rickets, while a figure below 30 indicates active rickets. This formula is useful in clinical practice but it has no real meaning in terms of physical chemistry. The plasma alkaline phosphatase activity (normal 56–190 IU/L) is markedly increased in rickets



**Figs 5.5A and B:** (A) Florid rickets showing splaying and fraying of ends of the long bones and (B) Radiograph of the same case as in rickets had healed

and only returns to normal with effective treatment. It is, in fact, a very sensitive and early reflection of rachitic activity but can be raised in a variety of unrelated disease states such as hyperparathyroidism, obstructive jaundice, fractures, malignant disease of bone and the "battered baby" syndrome. The mean 25-OHD<sub>3</sub> levels in healthy British children are 30 nmol/L (12.5 mg/L), although considerably greater concentrations are reported from the USA. In children with active rickets, the level of 25-OHD<sub>3</sub> may fall below 7.5 nmol/L (3 mg/L). However, it is not possible to equate the presence of rickets with particular absolute values for 25-OHD<sub>3</sub>, although its measurement can provide the most sensitive index of the vitamin D status of a population. Plasma 1,25(OH)<sub>2</sub> D can also be measured but is a specialised investigation.

### Differential Diagnosis

Few diseases can simulate infantile rickets. In hypophosphatasia, some of the clinical and radiological features resemble those seen in rickets, but their presence in the early weeks of life exclude vitamin D deficiency. Other features such as defective calcification of the membranous bones of the skull, low plasma alkaline phosphatase and hypercalcaemia are never found in rickets. The characteristic features of achondroplasia—short upper limb segments, large head with relatively small face and retroussé nose, trident arrangement of the fingers, lordosis, waddling gait and X-ray evidence of endochondral ossification—are unmistakably different from anything seen in rickets. The globular enlargement of the hydrocephalic skull is quite distinct from the square bossed head of severe rickets. The bone lesions of congenital syphilis are present in the early months of life and are associated with other characteristic clinical signs such as rashes, bloody snuffles, hepatosplenomegaly and

lymphadenopathy. In later, childhood the sabre-blade tibia of syphilis shows anterior bowing and thickening which is different from rachitic bowing. Some healthy toddlers show an apparent bowing of the legs due to the normal deposition of fat over the outer aspects; this is unimportant and temporary, and there are no other signs of skeletal abnormality. Other normal young children have a mild and physiological degree of genu valgum due to a mild valgus position of the feet; in rachitic genu valgum, there will be other rickety deformities. Other types of rickets due to coeliac disease and renal disease must be excluded by appropriate investigations. Their existence is almost always indicated in a carefully taken history.

### Prevention

It is important to keep a degree of awareness of the problem of rickets, as the feeding pattern of many adolescents in inner city areas would indicate that they are unaware and/or unconcerned of the need to ensure an adequate vitamin D status for themselves and for their children. Departments of health are striving hard to maintain a public awareness of the importance of nutrition to health and through the supply of vitamin D fortified foods are endeavouring to prevent the recrudescence of this preventable disorder. The United States Institute of Medicine estimates 'adequate intakes' (AI) of vitamin D for those with no sun-mediated synthesis in the skin—for ages 0–50 years (including pregnancy and lactation), the AI is 5 µg/day.

### Treatment

Although rickets can be healed by exposure to UV light it is more practicable and reliable to administer vitamin D in adequate dosage by mouth. Nutritional deficiency of vitamin D is best treated with cholecalciferol or ergocalciferol. A suitable dose is 1,600–2,000 IU orally (1 mg calciferol = 40,000 IU). This can be achieved using the BP or a proprietary concentrated preparation. Although calcium deficiency *per se* very rarely has caused rickets there should be an adequate amount of calcium in the infant's diet (approx 600 mg/day). This is contained in 1 pint (600 ml) of milk per day. An alternative method of treatment, especially useful where it is suspected that the parents are unreliable and unlikely to administer a daily dose of vitamin D, is the oral or intramuscular administration of a massive dose of vitamin D (Stoss therapy, 300,000–600,000 IU). It is, however, uncertain how much of such a large dose the body can utilise although rapid healing of rickets can be confidently expected. Some children are unusually sensitive to vitamin D and a rare condition with elfin facial appearance, William syndrome can occur.

Even major deformities will disappear with adequate treatment in the young child and surgical correction is rarely required. The child should be kept from weight-bearing until X-rays show advanced healing, to prevent aggravation of the deformities. The parent of a rachitic child requires education in nutrition and childcare. They should be urged to take the child, after treatment, for regular supervision by their family doctor or at a local child health clinic.

#### Key Learning Point

- Children receiving pharmacological doses of vitamin D or its analogues should have their plasma-calcium level checked at intervals of once or twice a week because excessive supplementation may cause hypercalcaemia.

## VITAMIN C (ASCORBIC ACID) DEFICIENCY

### Aetiology

The primary cause is an inadequate intake of vitamin C (ascorbic acid), a vitamin that the human unlike most other animals is unable to synthesise within his own body. It is rare in the breastfed infant unless the mother has subclinical avitaminosis C. Cow's milk contains only about a quarter of the vitamin C content of human milk and this is further reduced by boiling, drying or evaporating. Scurvy is particularly common in infants who receive a high carbohydrate diet. The suggested recommended dietary allowance is 35 mg/day.

### Pathology

Vitamin C deficiency results in faulty collagen, which affects many tissues including bone, cartilage and teeth. The intercellular substance of the capillaries is also defective. This results in spontaneous haemorrhages and defective ossification affecting both the shafts and the metaphyseal-epiphyseal junctions. The periosteum becomes detached from the cortex and extensive subperiosteal haemorrhages occur; these explain the intense pain and tenderness, especially of the lower extremities.

### Clinical Features

Increasing irritability, anorexia, malaise and low-grade fever develop between the ages of 7 months and 15 months. A most striking feature is the obvious pain and tenderness which the infant exhibits when handled, e.g. during napkin changing. The legs are most severely affected and they characteristically assume a position ("frog-position") in which the hips and knees are flexed and the feet are rotated outwards. Gums become swollen and discoloured and may bleed; this is seen only after teeth have erupted and the teeth may become



loose in the jaws. Periorbital ecchymosis (“black eye”) or proptosis due to retro-orbital haemorrhage is common but haemorrhages into the skin, epistaxis or gastrointestinal haemorrhages are not commonly seen in infantile scurvy. The anterior ends of the ribs frequently become visibly and palpably swollen but this does not affect the costal cartilages as in rickets; the sternum has the appearance of having been displaced backwards. Microscopic haematuria is frequently present.

### Radiological Features

The diagnosis is most reliably confirmed by X-rays. The shafts of the long bones have a “ground-glass” appearance due to loss of normal trabeculation. A dense white line of calcification (Fraenkel’s line) forms proximal to the epiphyseal plate and there is often a zone of translucency due to an incomplete transverse fracture immediately proximal to Fraenkel’s line. A small spur of bone may project from the end of the shaft at this point (“the corner sign”). The epiphyses, especially at the knees, have the appearance of being “ringed” by white ink. Subperiosteal haemorrhages only become visible when they are undergoing calcification but a striking X-ray appearance is then seen (Fig. 5.6).

### Diagnosis

Measurement of vitamin C in serum and leukocytes is the common means of assessing vitamin C status. For practical purposes, measurement of vitamin C in serum is preferred over leukocyte measurement. Measurement of urinary vitamin C in patients suspected of scurvy can provide supportive diagnostic information. There are no reliable functional tests of vitamin C.

#### Key Learning Points

- Vitamin C deficiency manifests as scurvy.
- Vitamin C status is assessed by plasma and leukocyte concentrations.
- At intakes above 100 mg/day the vitamin is excreted quantitatively with intake in the urine.
- There is little evidence that high intakes have any beneficial effects, but equally there is no evidence of any hazard from high intakes.

### Treatment and Prevention

The most rapid recovery can be obtained with oral ascorbic acid, 200 mg per day. There is no advantage in parenteral administration. Excess vitamin C is excreted in the urine and there is no evidence that vitamin C is in any way poisonous. In developed countries, the usual cause of vitamin C deficiency is ignorance of the parents of the need to supply adequate amounts



**Fig. 5.6:** Radiograph from a case of infantile scurvy in the healing stage with calcified subperiosteal haematoma. Note also “ringing of epiphyses, Fraenkel’s white lines and proximal zone of translucency

of vitamin C or alternatively some obsessive parents boil fruit juices, which would normally supply adequate vitamin C to the child, but the act of boiling destroys the ascorbic acid.

## VITAMIN B DEFICIENCIES

The B vitamins are widely distributed in animal and vegetable foods. Deficiency of one of the B group vitamins is commonly associated with deficiencies of the others. The main functions of B vitamins are as cofactors for metabolic processes or as precursors of essential metabolites. Deficiencies occur when there is severe famine, where there are dietary fads, where diets are severely restricted or where there has been inappropriate preparation of the food. Many B vitamins are destroyed by cooking.

### Thiamine (Vitamin B<sub>1</sub>) Deficiency

Thiamine, as are all the B vitamins, is water soluble and readily destroyed by heat and alkali. It is necessary for mitochondrial function and for the synthesis of acetylcholine. It is present in a wide variety of foods but deficiency states have been particularly common in communities where polishing rice and refining flour has removed the vitamin B containing husks. Beriberi is now rare in the countries where it was originally described—Japan, Indonesia and Malaysia.

#### Clinical Features

Deficiency of thiamine (beriberi) causes clinical manifestations in the nervous and cardiovascular systems predominantly although all tissues are affected. There is

degeneration of peripheral nerve fibres and haemorrhage and vascular dilatation in the brain (Wernicke encephalopathy). There can be high output cardiac failure and erythemas. Signs of the disease develop in infants born to thiamine deficient mothers at the age of 2–3 months. They appear restless with vasodilatation, anorexia, vomiting and constipation and pale with a waxy skin, hypertonia and dyspnoea. There is peripheral vasodilatation and bounding pulses with later development of, hepatomegaly and evidence of cardiac failure. This is due to a combination of the peripheral vasodilatation and decreased renal flow. This is known as the “wet” form of beriberi. There is reduction of the phasic reflexes at knee and ankle.

In older children “dry” beriberi or the neurological complication of thiamine deficiency results in paraesthesia and burning sensations particularly affecting the feet. There is generalised muscle weakness and calf muscles are tender. Tendon reflexes may be absent, a stocking and glove peripheral neuritis develops and sensory loss accompanies the motor weakness. Increased intracranial pressure, meningism and coma may follow.

#### Key Learning Points

- ➔ The classical thiamine deficiency disease beriberi, affecting the peripheral nervous system, is now rare.
- ➔ Thiamine status is assessed by erythrocyte transketolase activation coefficient.

#### Diagnosis

There are few useful laboratory tests although in severe deficiency states the red blood cell transketolase is reduced and lactate and pyruvate may be increased in the blood, particularly after exercise.

#### Treatment

The usual thiamine requirement is 0.5 mg per day during infancy and 0.7–1 mg daily for older children. Pregnant and lactating women should have a minimal intake of 1 mg per day. Treatment of B<sub>1</sub> deficiency is 10 mg per day for infants and young children increasing to 50 mg per day for adults. In the infant with cardiac failure intravenous or intramuscular thiamine (100 mg daily) can be given. The response can at times be dramatic. There is no evidence of any toxic effect of high intakes of thiamine, although high parenteral doses have been reported to cause anaphylactic shock.

### Riboflavin (Vitamin B<sub>2</sub>) Deficiency

#### Clinical Features

Deficiency is usually secondary to inadequate intake although in biliary atresia and chronic hepatitis there may be malabsorption. Clinical features are those common to

a number of B group deficiency states namely cheilosis, glossitis, keratitis, conjunctivitis, photophobia and lacrimation. Cheilosis begins with pallor, thinning and maceration of the skin at the angles of the mouth and then extends laterally. The whole mouth may become reddened and swollen and there is loss of papillae of the tongue. A normochromic, normocytic anaemia is secondary to bone marrow hypoplasia. There may be associated with seborrhoeic dermatitis involving the nasolabial folds and forehead. Conjunctival suffusion may proceed to proliferation of blood vessels onto the cornea.

#### Diagnosis

Urinary riboflavin excretion of less than 30 mg per day is characteristic of a deficiency state. There is reduction of red cell glutathione reductase activity.

#### Treatment

Riboflavin is present in most foods although the best sources are milk and milk products, eggs, liver, kidney, yeast extracts and fortified breakfast cereals. However, riboflavin is unstable in UV light, and after milk has been exposed to sunlight for 4 hours, up to 70% of riboflavin is lost.

In childhood, the daily requirement for riboflavin is 0.6 mg per 4.2 mJ (1,000 kcal) and treatment of a deficiency state requires 10 mg oral riboflavin daily. In some circumstances, riboflavin 2 mg three times per day can be given by intramuscular injection until there is clinical improvement.

#### Key Learning Points

- ➔ Riboflavin deficiency is relatively common.
- ➔ Phototherapy for neonatal hyperbilirubinaemia can cause iatrogenic riboflavin deficiency.

### Pellagra (Niacin Deficiency)

Niacin is the precursor of nicotinamide adenine dinucleotide (NAD) and its reduced form NADP. It can be synthesised from tryptophan and pellagra tends to occur when maize, which is a poor source tryptophan and niacin, is the staple diet. Niacin is lost in the milling process. Communities where millet, which has a high leucine content, is consumed also have a high incidence of pellagra.

#### Clinical Features

The classical triad for pellagra is diarrhoea, dermatitis and dementia although in children the diarrhoea and dementia are less obvious than in the adolescent and adult. There is light-sensitive dermatitis on exposed areas, which can result in blistering and desquamation of the skin. On healing the skin becomes pigmented (Fig. 5.7). The children are apathetic



**Fig. 5.7:** Pellagra—“casal's necklace” on the neck

and disinterested and feed poorly due to an associated glossitis and stomatitis.

### Diagnosis

The two methods of assessing niacin deficiency are measurement of blood nicotinamide nucleotides and the urinary excretion of niacin metabolites, neither of which is wholly satisfactory.

### Treatment

The normal requirement for niacin in infancy and childhood is 8–10 mg per day when the tryptophan intake is adequate. Deficiency states can be treated with up to 300 mg per day given orally but care must be taken, as large doses will produce flushing and burning sensations in the skin. There is almost always other associated vitamin B deficiencies and these should be supplied during the treatment of pellagra. Due to the intimate involvement of the three major B vitamins described in intermediary metabolism the requirement is best determined in relation to energy intake. Recommended intakes on this basis are: thiamine 0.4 mg per 4.2 mJ (100 kcal); riboflavin 0.55 mg per 4.2 mJ and niacin 6.6 mg per 4.2 mJ.

### Vitamin B<sub>6</sub> (Pyridoxine) Deficiency

Vitamin B<sub>6</sub> occurs in nature in three forms: (1) pyridoxine, (2) pyridoxal and (3) pyridoxamine, which are interconvertible within the body. The principal one in the body and in food is pyridoxal.

There may be inadequate intake of dietary pyridoxine when there is prolonged heat processing of milk and cereals or when unsupplemented milk formulae or elemental diets are used. There can be inadequate absorption in coeliac disease and drug treatment with isoniazid, penicillamine and oral contraceptives will aggravate deficiency states.

The disorder has to be differentiated from pyridoxine dependency in which pyridoxine dependent convulsions and anaemia are secondary to a genetic disorder of the apoenzyme. Deficiency on its own is rare; it is most often seen with deficiencies of other vitamins or with protein deficiency.

### Clinical Features

Pyridoxine deficiency states result in convulsions, peripheral neuritis, cheilosis, glossitis (as in riboflavin deficiency), seborrhoea and anaemia and impaired immunity. The anaemia is microcytic and is aggravated when intercurrent infections complicate the clinical picture. There may be oxaluria with bladder stones, hyperglycinaemia, lymphopaenia and decreased antibody production.

### Diagnosis

There is increased xanthurenic acid in the urine after an oral dose of the amino acid tryptophan. Glutamine-oxaloacetic acid transaminase is reduced in the red cells.

### Treatment

The usual requirements for non-pyridoxine dependent individuals are 0.5 mg per day in infancy and 1 mg per day in children.

### Vitamin B<sub>12</sub> Deficiency

If maternal vitamin B<sub>12</sub> status is satisfactory the reserves of B<sub>12</sub> in the term newborn infant should last throughout the first year of life especially if the infant is breastfed. Dietary deficiency of vitamin B<sub>12</sub> is unusual except amongst the strict vegans who consume neither milk nor eggs. Absorption of B<sub>12</sub> requires a gastric intrinsic factor (IF), which promotes absorption in the terminal ileum. Deficiency of IF, secondary to gastric achlorhydria is rare in childhood. It has been reported secondarily to the development of gastric parietal cell antibody but this is extremely rare. Familial pernicious anaemia is secondary to a series of autosomal recessively inherited defects in B<sub>12</sub> metabolism or in the function of B<sub>12</sub> binding proteins. Resection of the terminal ileum or Crohn's disease will predispose children to B<sub>12</sub> deficiency unless B<sub>12</sub> supplementation is given.

### Clinical Features

Pallor, anorexia and glossitis are common features. Paraesthesia with loss of position and vibration sense is a disorder of adolescence rather than childhood. There is a megaloblastic anaemia with neutropaenia, thrombocytopaenia and hypersegmentation of polymorphonuclear leukocytes. The bone marrow shows a megaloblastic, erythroid picture with giant metamyelocytes.

The neurological signs of subacute combined degeneration of the cord with peripheral neuritis; degeneration of the dorsal columns and corticospinal tract is a late phenomenon as is retrobulbar neuropathy.

### Diagnosis

Serum vitamin B<sub>12</sub>, normal levels range from 200 pg/ml to 900 pg/ml or over 150 pmol/L. Deficiency is indicated by values below this. Elevated serum or urinary excretion of methylmalonate and raised plasma homocysteine are the other biochemical tests indicating low B<sub>12</sub> status. Schilling test is used to confirm the diagnosis of pernicious anaemia. It measures oral absorption of vitamin B<sub>12</sub> labelled with radioactive cobalt on two occasions, the first without and the second test with IF.

#### Key Learning Point

- Dietary deficiency of vitamin B<sub>12</sub> occurs only in strict vegans; there are no plant sources of the vitamin B<sub>12</sub>.

### Treatment

In the rare instance of dietary deficiency oral supplementation is satisfactory. Where there is inadequate absorption intramuscular injections, initially of 1 mg per day reducing to 1 mg at 3 monthly intervals in the light of clinical improvement is the usual management in older children and adolescents. Hydroxocobalamin has completely replaced cyanocobalamin as the form of vitamin B<sub>12</sub> of choice for therapy; it is retained in the body longer than cyanocobalamin and thus for maintenance therapy can be given at intervals of up to 3 months. Treatment is generally initiated with frequent administration of intramuscular injections to replenish the depleted body stores.

### Folate Deficiency

The word folic is from the Latin 'folia' (leaf), coined in 1941 for an early preparation of this vitamin from spinach leaves.

Deficiency of folic acid is widespread in many communities and is a known factor in the aetiology of neural tube defects. Although found widely in plant and animal tissues the vitamin is easily destroyed by cooking and storage processes. Requirements for growth during foetal and neonatal life and childhood are high. Deficiency states are likely to occur during childhood particularly when there is excessive cell turnover such as occurs in the haemolytic anaemias and in exfoliative skin conditions such as eczema. Folic acid is the precursor of tetrahydrofolate, which is intimately involved in a series of enzyme reactions of amino acid, purine and intermediary metabolism. Folate is absorbed in the duodenum and in malabsorptive states including coeliac

disease folate deficiency is common. In some situations where the small intestine is colonised by bacteria (blind loop syndrome), folate is diverted into bacterial metabolism. Some anticonvulsants and antibacterial agents either increase the metabolism of folate or compete with folate.

### Clinical Features

Megaloblastic anaemia and pancytopenia together with poor growth are the result of the cessation of cell division, which comes about when nucleoprotein formation is interrupted due to the lack of synthesis of purines and pyrimidines.

### Diagnosis

The blood picture is one of a megaloblastic anaemia with neutropenia and thrombocytopenia. The neutrophils contain large hypersegmented nuclei and bone marrow is hypercellular due to erythroid hyperplasia. Although the reticulocyte count is low nucleated red cells appear in the peripheral blood. Red cell folate measurements are less than 75 ng/ml and it gives a better idea of cellular status. There is a close interaction of B<sub>12</sub> and folic acid in the synthesis of tetrahydrofolate and formyltetrahydrofolate, which are required for purine ring formation. With isolated folate deficiency, there are none of the neuropathies associated with the megaloblastic anaemia of B<sub>12</sub> deficiency.

### Treatment

Response to treatment with oral or parenteral folic acid 2–5 mg per day is usually rapid. If there is a combined folate and B<sub>12</sub> deficiency folic acid alone may cure the megaloblastic anaemia but the subacute combined degeneration of the cord will persist until B<sub>12</sub> is given. In order to reduce the risk of neural tube defect, it is recommended that all women should ensure an intake of 0.4 mg folic acid/day from before conception and throughout pregnancy. Any woman giving birth to an infant with a neural tube defect should have 4 mg folic acid from before conception and throughout pregnancy. Folinic acid is also effective in the treatment of folate-deficient megaloblastic anaemia but it is normally only used in association with cytotoxic drugs; it is given as calcium folinate.

#### Key Learning Points

- Dietary folate deficiency is not uncommon; deficiency results in megaloblastic anaemia.
- Low folate status is associated with neural tube defects, and periconceptional supplements reduce the incidence.
- Folate status can be assessed by measuring plasma or erythrocyte concentrations.

## VITAMIN E (TOCOPHEROL) DEFICIENCY

Vitamin E deficiency except in the preterm infant is rare. In the preterm, vitamin E deficiency is occasionally associated with haemolytic anaemia and may contribute to the membrane damage associated with intraventricular haemorrhage and bronchopulmonary dysplasia. Vitamin E is essential for the insertion and maintenance of long chain polyunsaturated fatty acids in the phospholipid bilayer of cell membranes by counteracting the effect of free radicals on these fatty acids. When the essential fatty acid content of the diet is high, vitamin E is required in increased amounts. Plant foods high in fat, particularly polyunsaturated fat, are the best sources of vitamin E. Natural sources of vitamin E are oily fish, milk, cereal, seed oils, peanuts and soya beans. Children with abetalipoproteinaemia have steatorrhoea and low circulating levels of vitamin E associated with neurological signs. More recently older children and adults with cystic fibrosis have developed neurological signs similar to those in abetalipoproteinaemia due to vitamin E deficiency. In any child with fat malabsorption such as cystic fibrosis and cholestatic liver disease, it would be important to give supplementary vitamin E in addition to correcting the underlying fat malabsorption where possible. The most commonly used index of vitamin E nutritional status is the plasma concentration of alpha-tocopherol. From the plasma concentration of alpha-tocopherol required to prevent haemolysis *in vitro*, the average requirement is 12 mg/day. Some neonatal units still give a single intramuscular dose of vitamin E at birth to preterm neonates to reduce the risk of complications; however, no trials of long-term outcome have been carried out. The intramuscular route should also be considered in children with severe liver disease when response to oral therapy is inadequate.

### Key Learning Point

- Premature infants have inadequate vitamin E status and are susceptible to haemolytic anaemia.

## VITAMIN K DEFICIENCY

Vitamin K is necessary for the production of blood clotting factors and proteins necessary for the normal calcification of bone. Osteocalcin synthesis is similarly impaired, and there is evidence that undercarboxylated osteocalcin is formed in people with marginal intakes of vitamin K who show impairment of blood clotting. Treatment with warfarin or other anticoagulants during pregnancy can lead to bone abnormalities in the foetus the so-called foetal warfarin syndrome, which is due to impaired synthesis of osteocalcin.

Because vitamin K is fat soluble, children with fat malabsorption, especially in biliary obstruction or hepatic

disease may become deficient. Neonates are relatively deficient in vitamin K and those who do not receive supplements are at risk of serious bleeds including intracranial bleeding. Therefore, newborn babies should receive vitamin K to prevent vitamin K deficiency bleeding (haemorrhagic disease of the newborn). Also babies born to mothers with liver disease or taking enzyme inducing anticonvulsant drugs (carbamazepine, phenobarbital, phenytoin), rifampicin or warfarin should receive vitamin K because they are at particular risk of vitamin K deficiency.

### Key Learning Points

- Dietary deficiency of vitamin K is rare.
- Newborn infants have low vitamin K status and are at risk of severe bleeding unless given prophylactic vitamin K.
- Vitamin K status is assessed by estimation of prothrombin time.

## BIOTIN AND PANTOTHENIC ACID

Biotin is a coenzyme (CoA) for several carboxylase enzymes. Biotin deficiency is very rare as biotin is found in a wide range of foods, and bacterial production in the large intestine appears to supplement dietary intake.

Pantothenic acid is part of CoA and of acyl carrier protein (ACP). Spontaneous human deficiency has never been described. As pantothenic acid is so widely distributed in foods, any dietary deficiency in humans is usually associated with other nutrient deficiencies.

## Copper Deficiency

Copper is the third most abundant dietary trace metal after iron and zinc and is found at high levels in shellfish, liver, kidney, nuts and whole grain cereals. In 1962, copper deficiency was reported in humans.

Copper is also an important constituent of many enzyme systems such as cytochrome oxidase and dismutase yet clinical copper deficiency states are rare except in very LBW infants, in states of severe protein energy malnutrition and during prolonged parenteral nutrition. The term infant is born with substantial stores of liver copper largely laid down in the last trimester of pregnancy bound to metallothionein. Preterm infants will, therefore, be born with inadequate liver stores of copper and may develop deficiency in the newborn period unless fed foods supplemented with copper. No estimated average requirement (EAR) or recommended dietary intake (RDI) has been estimated for copper. However, it is thought that the daily requirement for copper in term infants is 0.2 mg per day increasing to 1 mg per day by the end of the first year of life hereafter the requirement for copper is 1–3 mg per day. Human milk contains about 0.6 mmol (39 mg) per 100 ml copper but cow's milk only contains 0.13 mmol

(9 mg) per 100 ml. Many infant formulae are supplemented with copper. In soya-based infant formulas, phytate binding prohibits absorption and additional copper supplementation is required. Percentage absorption of copper is increased in deficiency states although, like iron, absorption is partly dependent on the form in which copper is presented to the gut. Other trace elements such as iron, zinc, cadmium, calcium, copper, sulphur and molybdenum interfere with copper absorption. After absorption the copper is bound to albumin in the portal circulation. Caeruloplasmin is formed in the liver and is the major transport protein for copper. Frank copper deficiency can be determined by the measurement of plasma copper concentrations or plasma caeruloplasmin, or by determination of the activities of copper-dependent enzymes such as superoxide dismutase. Therefore, plasma copper has been used as a measure of copper deficiency but caeruloplasmin also acts as an acute-phase reactant and will increase in stress situations particularly during infections. The normal plasma copper concentration is 11–25 mmol/L (0.7–1.6 mg/L) and caeruloplasmin 0.1–0.7 g/L. These values are decreased in deficiency states.

### *Clinical Features*

In preterm infants, there may be severe osteoporosis with cupping and flaring of the bone ends with periosteal reaction and submetaphyseal fractures. Severe bone disease has been reported in older infants on bizarre diets. It has been argued that subclinical copper deficiency may account for some of the fractures in suspected non-accidental injury. It is most unlikely that copper deficiency in an otherwise healthy child could result in unexplained fracture. To suggest that copper deficiency develops without obvious cause and results in bone fractures without other evidence of copper deficiency is at best unwise.

Menkes' syndrome, also called steely-hair or kinky-hair syndrome, is a rare X-linked disorder associated with disturbed copper metabolism. There is gross osteoporosis and progressive neurological impairment. Scalp hair is sparse and brittle with pili torti on microscopic examination. The disorder does not respond to copper therapy.

### **Selenium Deficiency**

Muscular dystrophy in lambs and calves has been reported in parts of the world where there is deficiency of selenium in the soil. In humans, Keshan disease has been reported in China. Selenium is essential for glutathione peroxidase activity which catalyses the reduction of fatty acid hydroperoxides and protects tissues from peroxidation. Thus selenium is important in maintaining the fatty acid integrity of phospholipid membranes and reducing free radical damage. It is found in fish, meat and whole grain and reflects the

soil selenium content of the region. Vitamin C improves the absorption of selenium.

### *Clinical Features*

In China, an endemic cardiomyopathy affecting women of childbearing age and children known as Keshan disease has been reported. The condition responds to selenium supplementation. In New Zealand, low selenium concentrations in the soil result in low plasma levels and in children with phenylketonuria (PKU) on a low phenylalanine diet low plasma levels of selenium have been reported. There is no obvious clinical abnormality in the New Zealand population although poor growth and dry skin has been reported in the selenium deficient PKU children.

Increasingly, epidemiological evidence as well as data from animal studies points to a role for selenium in reducing cancer incidence. However, it should be noted that while selenium is an essential micronutrient and supplementation or fortification of foods may in many cases be advantageous, in excess selenium is exceedingly toxic. The margin between an adequate and a toxic intake of selenium is quite narrow. Symptoms of selenium excess include brittle hair and nails, skin lesions and garlic odour on the breath due to expiration of dimethylselenide. Lack of dietary selenium has also been implicated in the aetiology of cardiovascular diseases, but the evidence is less convincing than for cancer.

### **Chromium Deficiency**

Chromium may be involved in nucleic acid metabolism and is recognised as a cofactor for insulin. It is poorly absorbed and there is some evidence that in the elderly, glucose tolerance can be improved by chromium supplementation. Chromium deficiency has been reported in severely malnourished children and in children on prolonged parenteral nutrition. Weight gain and glucose tolerance in such children has been reported to improve after chromium supplementation. In long-term parenteral nutrition peripheral neuropathy and encephalopathy have also been reported to respond to chromium administration.

### **Iodine Deficiency**

Endemic goitre has been recognised for many centuries in mountainous regions of the world. The Andes, Himalayas, mountains of Central Africa and Papua, New Guinea as well as Derbyshire in the United Kingdom, are areas where the condition has been recognised. Minimal requirements are probably less than 20 mg/day in infants and young children increasing to 50 mg/day during adolescence. Breast milk contains up to 90 mg/L. Goitre occurs when the iodine intake is less than 15 mg/day and results in a reduced serum

thyroxine ( $T_4$ ) but a decreased triiodothyronine ( $T_3$ ). Thyroid stimulating hormone (TSH) values increase. The introduction of iodised salt to areas of endemic goitrous and cretinism has largely eradicated goitre cretinism in these regions. Thus at present this is best achieved through iodine fortification of foods. Some plants including Brassicas, bamboo shoots act as goitrogens by inhibiting iodine uptake by the thyroid gland.

#### Key Learning Point

- ⇒ Iodisation of salt is the preferred way and greater than 60% of families in affected regions now have access to fortified salt.

### Fluoride

Fluoride is present in most foods at varying levels and also in drinking water, either naturally occurring or added deliberately. Fluoride content of teeth and bones is directly proportional to the amount ingested and absorbed from the diet. Fluoride has been recognised as an important factor in the prevention of caries. Where the fluoride content of the drinking water is less than  $700 \mu\text{g/L}$  (0.7 parts per million), daily administration of fluoride tablets or drops is a suitable means of supplementation. It is now considered that the topical action of fluoride on enamel and plaque is more important than the systemic effect. Systemic fluoride supplements should not be prescribed without reference to the fluoride content of the local water supply. Infants need

not receive fluoride supplements until the age of 6 months. Toothpaste or tooth powder which incorporate sodium fluoride or monofluorophosphate are also a convenient source of fluoride.

Higher intakes of fluoride (10 mg/L) are toxic and leading to fluorosis. However, fluorosis is common in parts of Southern Africa, the Indian subcontinent and China where there is a high fluoride content in the subsoil water, which enters the food chain either directly or via plants.

#### Key Learning Points

- ⇒ Fluoride is now considered that the topical action of fluoride on enamel and plaque is more important than the systemic effect. Also systemic fluoride supplements should not be prescribed without reference to the fluoride content of the local water supply.
- ⇒ Infants need not receive fluoride supplements until the age of 6 months.

### Other Trace Minerals

Manganese, molybdenum and cadmium are known to be necessary for health in animals but no clear human evidence of deficiency states are known to man. Following recent experience with zinc, copper and chromium, it seems likely that future research will lead to the identification of specific deficiencies of some of these other trace elements in infants and children.

# Respiratory Disorders

## INTRODUCTION

Respiratory disorders are very common in paediatrics. They are responsible for significant numbers of inpatient admissions, outpatient referrals and general practice consults. The Global Initiative for Asthma (GINA), global burden report ([www.ginasthma.com](http://www.ginasthma.com)) estimated that 300 million people of all ages and ethnicity worldwide have asthma. The 1993 World Development Report reported that acute respiratory infection caused 30% of all childhood deaths ([www.econ.worldbank.org](http://www.econ.worldbank.org)). This chapter covers common paediatric respiratory problems as well as some rarer ones.

A careful history and examination is vital in respiratory medicine. When a child presents with respiratory symptoms, e.g. a cough then the following should be asked.

## HISTORY AND EXAMINATION

- When did the cough start?
- Is it there all the time?
- What makes it better or worse?
- Is the cough productive of sputum? If so, is it green or blood stained? (Remember young children commonly swallow sputum rather than coughing it up). A persistent productive cough in a child can be a sign of bronchiectasis.
- Is it worse at night? (In asthmatics, night cough is a common problem)
- Are there other associated symptoms, e.g. wheeze, breathlessness, fever or lethargy?
- What treatments have been tried and what do the parents feel helped? Have they used the inhalers correctly?

### Past Medical History

- Previous operations and hospital admissions
- Presence of other conditions, e.g. eczema and hay fever as this may point to a diagnosis of atopy.

### Birth History

- Was the infant born preterm?
- Did they have respiratory difficulties?
- Birth weight.

### Family History

- Who lives with the child?
- Are there family members with respiratory illness, e.g. asthma?
- Is there a family history of hay fever or eczema?

### Social History

- Is there anyone in the house who smokes?
- Are there housing problems, e.g. dampness?
- What pets do they have?
- What recent travel have they had?

### Vaccination History

- Have all vaccines been given?

## RESPIRATORY INVESTIGATIONS

There are numerous respiratory investigations that can be done. These are carried out when clinically indicated.

- Chest imaging, e.g. chest radiograph, chest computed tomography (CT) scan and magnetic resonance imaging (MRI) of chest.
- Lung function studies—include spirometry and plethysmography. Figures 6.1 to 6.3 show a normal flow volume loop, an obstructed flow volume loop and a restrictive flow volume loop respectively. Figure 6.4 shows a plethysmograph (body box). These are similar to the studies performed in adults and usually children need to be at least 5 years old for them to do the manoeuvres needed. Incentive computer programmes have been



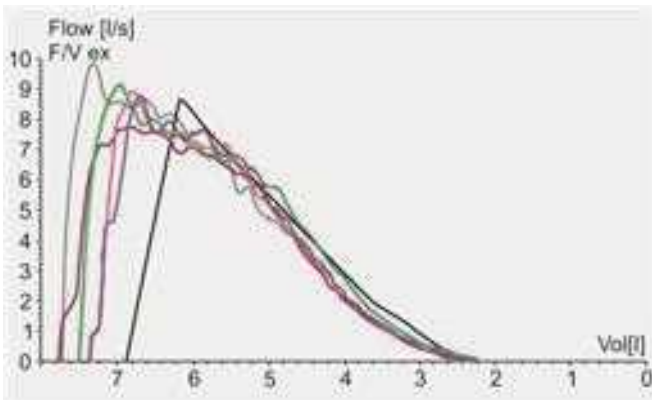


Fig. 6.1: Normal flow volume loop

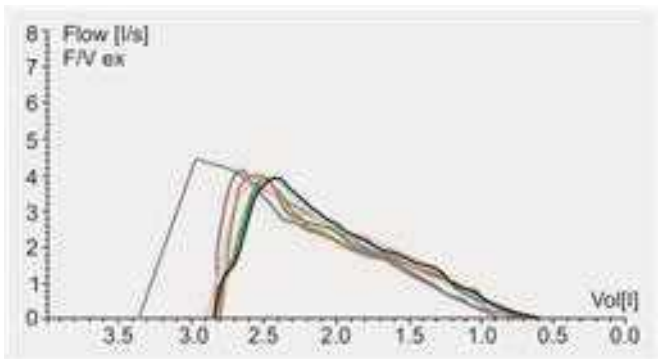


Fig. 6.3: Restrictive flow volume loop

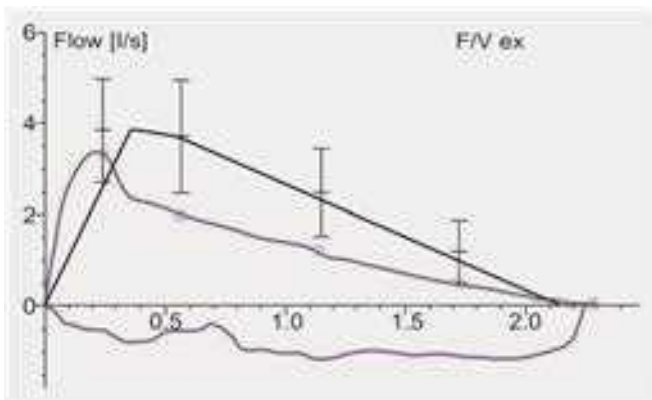


Fig. 6.2: Obstructed flow volume loop

developed to help to get consistent results. Exercise testing and histamine challenge are also performed. Infant lung function testing is available in some centres but at present it is mostly used for research purposes.

- pH studies: This uses placement of an oesophageal probe to measure acidity in the lower third of the oesophagus
- Barium swallow—performed for gastro-oesophageal reflux (GOR) and also helps to identify the presence of vascular rings that compress the oesophagus and trachea.
- Video-fluoroscopy of swallowing: This is a test used to look for swallowing problems, particularly aspiration.
- Flexible or rigid bronchoscopy
- Oxygen saturation studies and polysomnography
- Skin prick testing for common allergens
- Sweat test: used for cystic fibrosis (CF)
- Measurement of serum immunoglobulins (IgG, IgM and IgA)
- Measurement of total IgE.

## EXAMINATION

This includes measurement of a child's height and weight, which should be plotted on a growth chart.



Fig. 6.4: Body plethysmograph—used to measure lung volumes

## Inspection

- Is the child alert and talking normally? Acute respiratory distress can lead to breathlessness, confusion, difficulty in speaking and lethargy. Look for signs of respiratory distress, e.g. rapid breathing rate—note an infant's normal breathing rate that can be from 40 to 60 breaths per minute, as children get older their breathing rate gradually slows down. Generally teenagers' normal breathing rate is 15 breaths per minute.
- Is there use of accessory muscles of respiration? In an infant, doctor may see tracheal tug and head bobbing, in an older child there may be sub-costal recession and use of their sternocleidomastoid muscles.
- Is there central cyanosis or finger-clubbing? Are there scars or central venous access devices?
- Is the chest hyperinflated? Is there Harrison Sulci evident?

## Palpation

Chest excursion—can be difficult in a young infant.

Feel for apex beat and tracheal deviation—again this can be difficult in a young infant as they often have short necks.

## Percussion

- Percuss the chest for areas of dullness.

## Auscultation

- Is air entry equal on both sides?
- Are the breath sounds normal?
- Are there added sounds, such as crackles, wheeze or stridor?

## Examination of Ear, Nose and Throat

- These should be inspected directly with an auroscope.

## THE RESPIRATORY TRACT IN CHILDREN

At birth the lungs have the same number of conducting airways, e.g. bronchial divisions as adults though they are much smaller. The number of alveoli present is only one third to one half of the total number in adult. Lung growth occurs by increasing the number of alveoli and their size and by increasing the size of the airways. The upper and lower airways in children are small and therefore prone to obstruction.

Infants predominantly use diaphragmatic breathing rather than using their intercostal muscles, as these are underdeveloped. Children's ribs lie more horizontally and do not contribute as much to expansion of their chests. Their rib cage is less bony than in adults and is therefore more compliant and this can also make them more prone to respiratory difficulties.

Congenital abnormalities of the respiratory tract are rare. They can be divided into abnormalities of the upper airways, e.g. larynx and above, and of the lower respiratory airways.

## Congenital Abnormalities of the Upper Respiratory Tract

### *Choanal Atresia*

Choanal atresia is a narrowing or blockage of the nasal airway by membranous or bony tissue. It is thought to result from persistence of the membrane between the nasal and oral spaces during foetal development. It can be complete or partial, bilateral or unilateral and bony or membranous. The newborn is an "obligate nose breather", meaning it must breathe through its nose. In fact, almost the only time an infant does not breathe through its nose, when it is crying.

Bilateral choanal atresia causes acute breathing problems and cyanosis soon after birth. The cyanosis is typically relieved when the baby cries. There can also be persistent

green thick nasal secretions. The diagnosis may be suggested by failure to pass a nasogastric tube down the nose. Nasal endoscopy and a CT scan of the choanal area can also help to delineate how severe the atresia is. Choanal stenosis can lead to noisy breathing and difficulty in feeding. Choanal atresia is surgically managed.

It is well recognised that approximately 47% of children with choanal atresia can have other congenital abnormalities—the "CHARGE" association in which there are 7 main types of abnormalities noted: coloboma, heart defects, atresia (choanal), retardation (mental and growth), genital anomaly, ear anomaly and deafness. This is an association caused by a developmental defect involving the midline structures of the body, specifically affecting the craniofacial structures. Children need to have abnormalities of at least 4 out of the 7 organs to have the "CHARGE" association. The severity of abnormalities can vary.

Therefore, a child with choanal abnormalities should be examined carefully and investigated to look for these features.

### *Laryngomalacia*

This is a common condition of unknown cause where the larynx is floppier than normal, the epiglottis is large and differently shaped, the arytenoids are also floppy and on inspiration the larynx collapses inwardly obstructing the airway causing stridor. Stridor is usually present soon after the birth. It is louder on inspiration, on crying and when there is an upper respiratory tract infection (URTI). Laryngomalacia does not usually cause difficulty in breathing or feeding unless severe, but it can be associated with apnoea, if severe. There can be sub-costal recession due to the obstruction of airflow. The baby's voice should be normal.

Diagnosis is made by history and clinical findings of a well child with stridor. Infants with difficulty in breathing or feeding do need visualisation of their upper airways by flexible laryngoscopy. This can be done without sedation. In fact the dynamic airway is best seen in this way. Laryngomalacia rarely needs treatment and infants usually grow out of it. If severe, then aryepiglottoplasty can be used.

However, normal laryngoscopy in a child with persistent stridor warrants flexible or rigid bronchoscopy of the entire bronchial tree, as there may be subglottic or tracheal stenosis.

### *Subglottic Stenosis*

This can occur as a primary problem, e.g. subglottic web. However, it is more often seen in infants who have had previous episodes of intubation. It can be life-threatening. Treatment can include tracheal reconstruction using a cartilage graft. Infants may initially need a tracheostomy.

### *Haemangiomas of the Airways*

These are rare. The abnormal blood vessels can obstruct the larynx. They can shrink in response to steroids, which may have been given in the mistaken thought that the infant's stridor is due to croup. Treatment can include surgical removal of the lesions, laser therapy and direct injection of corticosteroids. If these managements fail then tracheostomy may be needed.

### *Laryngeal Papillomatosis*

This is a rare condition where infection with the *human papillomavirus*, leads to papillomata in the larynx, which causes hoarseness and stridor. The infection is usually acquired prenatally. Treatment involves laser therapy of the lesions. Anti-viral treatment with cidofovir can also be used. This condition requires multiple lasering procedures over a long period of time. If the papillomas spread to the lower respiratory tract then the outcome is generally worse and death can occur due to severe lung destruction.

### *Tracheobronchomalacia*

This is a condition where the trachea, one particular bronchus or the whole bronchial tree is floppy and fails to maintain airway patency due to an abnormality of the cartilaginous ring and hypotonia of the myoelastic elements. There is a collapse of the affected area on breathing in. It can occur in extreme prematurity or when there is an aberrant vessel, e.g. pulmonary artery sling where the left pulmonary artery comes off the right pulmonary artery and encircles the right mainstem bronchus and trachea. These aberrant vessels can also press on the oesophagus. It can present with stridor or with apparent life-threatening event (ALTE). Investigations to look for this condition and to assess its severity include barium swallow, bronchoscopy, cardiac echo, and MRI of the great vessels. The treatment is dependent on the cause.

### *Tracheal Stenosis*

Congenital tracheal stenosis is a rare condition where there is focal or diffuse complete tracheal cartilage rings. This results in narrowing or stenosis of the trachea. It can occur on its own or in association with a vascular ring, e.g. pulmonary artery sling. Acquired tracheal stenosis can occur secondary to prolonged intubation or infection in the trachea. It can present with breathing difficulties and stridor on inspiration and expiration. It has significant morbidity and can have significant mortality, if severe. Tracheal reconstruction is often needed.

### *Tracheo-oesophageal Fistula with Oesophageal Atresia*

Here there is a failure of embryonic development of the trachea and oesophagus. In oesophageal atresia the oesophagus is a

blind ending pouch. This presents soon after birth when the infant cannot swallow its own secretions or milk and it often chokes. It will be difficult to pass a nasogastric tube. Any fluid aspirated from the nasogastric tube does not contain acid so the pH paper which is used to check the position of the tube will not turn red.

A tracheo-oesophageal fistula (TOF) is an abnormal connection between the trachea and oesophagus, which can occur along with an oesophageal atresia. A TOF usually presents early with recurrent choking with feeds and often associated with desaturations. Treatment is surgical. The airways of babies with TOF can be malacic and babies post-repair can have ongoing respiratory difficulties.

In 25% of cases other gastrointestinal malformations, e.g. imperforate anus, pyloric stenosis and duodenal atresia occur. The "VACTERL" complex is a condition where children have vertebral, anal, cardiovascular, tracheo-oesophageal, renal, radial, and limb malformations.

### *Pulmonary Agenesis or Pulmonary Hypoplasia*

In pulmonary agenesis there is a failure of development of the bronchi and lung tissue of one or both lungs. Bilateral agenesis is incompatible with life. Babies born with one lung can have a normal life expectancy. These abnormalities are rare. More common is pulmonary hypoplasia where one or both lungs fail to develop properly—they have reduced bronchial branches, alveoli and blood vessels. Bilateral pulmonary hypoplasia is found in Potter syndrome where there is renal agenesis and oligohydramnios. The severity of the hypoplasia is dependent on what gestational age the arrest of development occurs. The earlier this occurs the worse the outlook. Most cases of pulmonary hypoplasia are seen as a secondary consequence of congenital diaphragmatic hernia.

### *Congenital Diaphragmatic Hernia*

In the first few weeks of foetal life there is a communication between the pleural and peritoneal cavities via the pleuro-peritoneal canal. This usually closes between 8 weeks and 10 weeks of gestation. Failure of this closure results in a defect in the diaphragm. The abdominal contents can then herniate through into the chest compressing the intrathoracic structures leading to poor lung development. Eighty-five percent of congenital diaphragmatic hernias are left sided. They occur in 1 in every 2,500–3,000 births.

The mortality rate in this condition is high about 40%. The mortality occurs from the pulmonary hypoplasia and also the elevated pulmonary artery pressures (pulmonary hypertension). Larger defects are associated with worse herniation and more severe hypoplasia. In 10% of children have other abnormalities. This condition can be detected antenatally by ultrasound—if detected, the infant should be



**Fig. 6.5:** Left-sided congenital diaphragmatic hernia

delivered in a unit where there is a neonatal surgical team on site.

An infant with a large diaphragmatic hernia usually presents within the first few hours after birth with breathing difficulties and cyanosis. If the hypoplasia is severe the baby may have obvious difficulties and cyanosis just after birth. Treatment involves resuscitation and stabilisation with intubation and ventilation. Chest X-ray (CXR) confirms the diagnosis showing herniation of the bowel into the chest and usually mediastinal displacement (Fig. 6.5). A nasogastric tube should be passed to decompress the stomach. Surgery is then performed to repair the defect. Nitric oxide, extracorporeal membrane oxygenation (ECMO) and high frequency oscillation have all been used to try to stabilise infants prior to surgery.

## OTHER CONGENITAL LUNG ABNORMALITIES

### Congenital Lobar Emphysema

This is a rare condition where there is over expansion of a pulmonary lobe with resultant compression of the remaining ipsilateral lung (Fig. 6.6). This is caused by an abnormally narrow bronchus where there is weakened or absent bronchial cartilage, so that there is air entry when the baby breathes in but the narrow bronchial lumen collapsed during expiration. This can present with breathing or feeding difficulties, which worsen with intercurrent respiratory infection. The treatment is surgical excision of the affected lobe.

### Congenital Cystic Adenomatoid Malformation of the Lung

In congenital cystic adenomatoid malformation of the lung (CCAM), there is an abnormal cystic development of lung



**Fig. 6.6:** Congenital lobar emphysema of left upper lobe

tissue during weeks 7–35 of gestation. Large CCAMs may be associated with hydrops foetalis in as many as 40%, which has a significant mortality. Hydrops is thought to arise from compression of the inferior vena cava by the CCAM, which affects venous, that returns to the heart causing low cardiac output and effusions. The CCAM can also press on the parts of the lung, which are growing normally and cause them to be hypoplastic leading to respiratory difficulties. Large CCAMs can be detected by antenatal ultrasound. Small CCAMs may go unnoticed for years until someone has a chest radiograph for another reason or until they become infected. Treatment is usually surgical excision of the affected lobe(s).

### Congenital Pulmonary Sequestration

In this condition there is an abnormal development of primitive lung tissue, which does not communicate with the bronchial tree and receives its blood supply from one or more systemic vessels rather than the pulmonary circulation. It can present with cough and recurrent chest infections. Treatment is surgical excision of the affected area.

### Congenital Abnormalities of the Thoracic Skeleton

Common congenital abnormalities of the thorax include pectus excavatum where the sternum and several ribs grow abnormally leading to a “caved in” shape to the anterior chest wall and pectus carinatum where the growth abnormality leads to an anterior protrusion of the chest wall. Pectus excavatum is by far the commonest. These often cause concern due to the chest shape, but rarely lead to significant clinical symptoms. Corrective thoracic surgery is available for both these conditions, if warranted. More complex

thoracic skeletal abnormalities include those where there is a skeletal dysplasia. The most severe can cause affected infants to die soon after birth, e.g. asphyxiating thoracic dystrophy. There are a number of these rare conditions where corrective thoracic surgery and long term ventilatory support have had encouraging results. Thoracic scoliosis can be congenital or acquired where it is usually seen with significant hypotonia. Treatment of this includes thoracic brace and corrective thoracic surgery, e.g. anterior and posterior spinal fusion

## ACQUIRED ABNORMALITIES

### Upper Respiratory Tract

#### *Upper Respiratory Tract Infection*

Upper respiratory tract infection is common in children and usually viral in origin caused by rhinoviruses and adenovirus. Bacterial pathogens include *Streptococcus* and *Haemophilus influenzae*. The child will usually have fever, cough and nasal discharge and may be lethargic and refuse feeds. Common examination findings include an inflamed throat and often inflamed tympanic membranes. Cervical lymphadenopathy may also be present. Treatment is supportive with fluids and antipyretics such as paracetamol.

Investigations can be done, such as throat swabs for virology and bacterial culture. If the child is not improving antibiotics may be needed, e.g. penicillin V. If breathing or feeding difficulties are evident children should be referred to hospital for further management.

#### *Tonsillitis*

This is where the tonsils are enlarged and inflamed, purulent exudates may be evident. The child may have difficulty in swallowing, and can be admitted for intravenous fluids. Throat swabs can be taken if symptoms are not resolving. Scottish intercollegiate guidelines network (SIGN) guidelines for the management of sore throats can be found at [www.sign.ac.uk](http://www.sign.ac.uk).

The indications for tonsillectomy are the following:

- Sore throats are due to acute tonsillitis
- Episodes of sore throat are disabling and prevent normal functioning
- Seven or more well documented, clinically significant, adequately treated sore throats in the preceding year or five or more such episodes in each of the preceding two years or three or more such episodes in each of the preceding three years.

*Streptococcus pyogenes* is the commonest pathogen isolated and is treated with penicillin V or erythromycin, if penicillin allergy is present. Remember, glandular fever caused by Epstein-Barr virus can cause significant throat inflammation and cervical lymphadenopathy, which will not respond to antibiotics.

### *Acute Otitis Media and Otitis Media with Effusion*

This is inflammation of the middle ear. It can be acute or chronic and can also be accompanied by fluid in the middle ear which is called otitis media with effusion (OME). Acute and chronic otitis media are very common presentations in children. Acute otitis media (AOM) usually presents with fever and pain in the ears. Young children who cannot yet speak may just be irritable and febrile and their parents may note them rubbing their ears. If the infection in the tympanic membrane causes to burst the parents may notice a yellow discharge and often the pain improves as the pressure is released. Hearing loss may also be present. There are guidelines for the management of this available on [www.sign.ac.uk](http://www.sign.ac.uk). On inspection of the tympanic membranes in AOM they may be bulging and red with fluid evident behind the tympanic membrane. In OME, the tympanic membrane may not be inflamed, but there is fluid evident. The main management of AOM is supportive with analgesia and fluids—if there is no improvement within a few days or a child gets worse, oral antibiotics, e.g. penicillin can be used. Children with more than four episodes of AOM in 6 months need to refer to an ENT specialist. In OME, the child needs its hearing assessed. If hearing loss is found a child should be referred to ENT as persistent hearing loss can cause speech delay. There is no place for antibiotics or decongestants in OME.

#### *Croup-laryngotracheobronchitis*

This is viral-induced inflammation of the larynx and trachea. Symptoms include a barking cough, inspiratory stridor and fever with rapid onset. Children may also have difficulty in breathing when it is severe. They may also show signs of respiratory distress with sub-costal recession. The management of this is high flow oxygen if needed, paracetamol and prednisolone or dexamethasone. If there are signs of significant distress nebulised adrenaline 5 ml of 1 in 1,000 should be given and anaesthetic help should be obtained.

#### *Acute Epiglottitis*

This is a bacterial inflammation of the epiglottis usually caused by *H. influenzae*. There is significant toxicity with high fever, drooling, stridor and difficulty in breathing. It has become less common due to the introduction of the HIB vaccination. Management of this should be prompt induction of anaesthesia, intubation and intravenous antibiotics.

## ACQUIRED LOWER RESPIRATORY TRACT PROBLEMS

### **Community Acquired Pneumonia**

#### *Viral Pneumonias*

Respiratory syncytial virus (RSV) is a negative-sense, enveloped the single stranded RNA virus which belongs to the *Paramyxoviridae* family. It is the single most important

cause of viral infection to lower respiratory tract in infancy and childhood worldwide. It is spread by direct contact with infected secretions either by touching infected surfaces or by an infected person coughing or sneezing directly at you. Classically, it causes bronchiolitis and it is most prevalent in the winter months. RSV causes inflammation and destruction of the airways leading to airway obstruction and air trapping.

Common symptoms are fever, coryza, cough, wheeze and breathing difficulty and feeding. Babies with bronchiolitis can have signs of respiratory distress with bilateral crackles on auscultation, low oxygen saturation levels, fever and dehydration. Many of these babies can be managed at home with frequent small feeds and antipyretics. The illness usually lasts for 1–2 weeks.

Indications for admission include significant breathing difficulties, dehydration, apnoea and those needing oxygen or those who are severely ill. Ninety per cent of those admitted are under 12 months of age. Chest radiographs typically show bilateral hyperinflation with increased lung markings bilaterally. They can show consolidation of one or more lobes of the lung in severe disease (Fig. 6.7). Premature infants, those with neuromuscular disease or those with haemodynamically significant congenital heart disease are more at risk of severe disease. ([www.sign.ac.uk/pdf/sign91.pdf](http://www.sign.ac.uk/pdf/sign91.pdf))

There is a monoclonal antibody preparation called palivizumab, which has been shown to reduce hospitalisation in children less than 6 months of age who were born at 35 weeks of gestation or less, those who are less than 2 years with chronic lung disease of prematurity and those with congenital heart disease. In some centres this is given to babies in those high-risk groups in the hope that it will prevent severe RSV infection.



Fig. 6.7: Right upper lobe collapse or consolidation

### Bacterial Pneumonia

The mortality from bacterial pneumonia is very low in developed countries in stark comparison to the high mortality rates in the developing world.

The most common bacterial pathogen is *Streptococcus pneumoniae* followed by *Mycoplasma pneumoniae*. In 20–60% of cases, pathogen is not identified and in fact there is often a mixture of pathogens. Evidence-based guidelines can be found on the British Thoracic Society website, [www.brit-thoracic.org.uk](http://www.brit-thoracic.org.uk).

Bacterial pneumonia usually presents with fever, cough and fast breathing or grunting. The child can be breathless at rest with signs of distress. On auscultation signs can include crackles and bronchial breathing. Lower lobe pneumonia can present with abdominal pain and fever. Much of the bacterial pneumonias are managed in the community with oral antibiotics, e.g. amoxicillin. Those who fail to respond to this will need further investigation and management. This can include chest radiography, blood cultures, full blood count and nasopharyngeal aspirate for viral culture for those less than 2 years of age. A right middle lobe pneumonia (Fig. 6.8).

Children who have significant difficulty in breathing, those who cannot feed, who are dehydrated, who need supplemental oxygen or who are systemically unwell should be admitted. They may need intravenous antibiotics, e.g. amoxicillin and intravenous fluids. Children with community-acquired pneumonia do not need routine follow-up chest radiographs. However, those who have a round pneumonia on their radiograph and those with lobar collapse should have a follow-up appointment and consideration of a repeat CXR at 6 weeks. Continuing symptoms despite treatment should also have a repeat chest radiograph performed.



Fig. 6.8: Right middle lobe pneumonia

### Pleural Infection in Children

Bacterial pneumonia in children can cause fluid in the pleural space (para-pneumonic effusions), which can become infected causing pus in the pleural space (empyema). They are rare, but the incidence is increasing. There are significant causes of morbidity in children, but mortality is rare unlike empyema in adults. Guidelines have been developed for the management of empyema in childhood ([www.brit-thoracic.org.uk](http://www.brit-thoracic.org.uk))

The most common bacterium responsible is *Streptococcus pneumoniae*. Such pleural collections usually present with persistent fever, cough and difficulty in breathing. The children may already be on antibiotics for a chest infection. If the collection is large they may have dullness to percussion on the affected side with reduced air entry. A large pleural collection shows as a complete “white out” of one lung (Fig. 6.9). An example of a smaller collection is shown in Figure 6.10. With an empyema the white cell count and the C reactive protein (CRP) are usually significantly raised. Blood cultures should also be taken. If the chest radiograph is suggestive of an effusion an ultrasound of the chest should be done to assess the amount of fluid present and look for loculation. Children should be treated with intravenous antibiotics which cover *S. pneumoniae*, e.g. amoxycillin or cefotaxime. In countries where *Staphylococcus aureus* is a common causative organism then cefuroxime can be substituted or flucloxacillin added. Close observation is needed.

Larger collections causing difficulty in breathing, those with persistent fever despite intravenous antibiotics and very loculated collections will most likely need drainage. Chest drains in children are usually inserted under general



Fig. 6.9: Large left-sided effusion



Fig. 6.10: Left-sided empyema

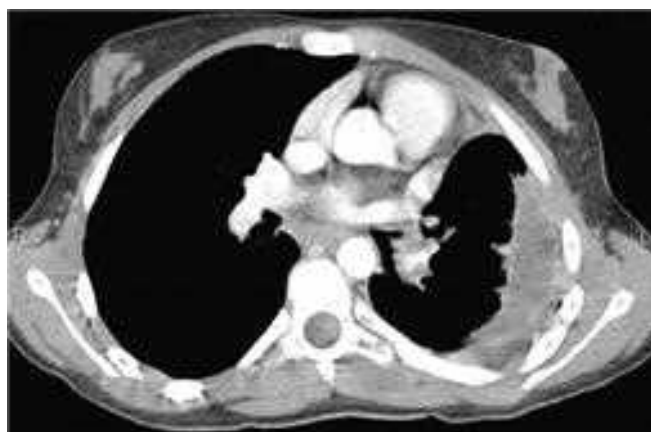


Fig. 6.11: Computed tomography (CT) scan showing left-sided empyema

anaesthetic. The pleural fluid should be sent for culture. Children need good pain relief afterwards to ensure early mobility. The chest drain usually stays in until it has stopped draining fluid. The majority of children with empyema responds well to intravenous antibiotics and drainage and makes a complete recovery. Intrapleural fibrinolytics, e.g. urokinase and tissue plasminogen activator can be instilled into the pleural space to try to break down the adhesions present in the pleural fluid.

Children who fail to respond may require further imaging, e.g. CT of the chest (Fig. 6.11) and may need more invasive thoracic procedures, e.g. decortication. Video-assisted thoracoscopic techniques are also being used to try to clear the pus from the pleural cavity. Once well enough to go home children need a follow-up CXR at approximately 6 weeks to ensure radiographic resolution.

Children without fever who present with a pleural effusion are of more concern as malignancies particularly lymphoma and leukaemia may present this way. In these children a chest CT is indicated sooner and the pleural fluid drained should be sent for cytological examination.

### *Gastro-oesophageal Reflux (GOR)*

Reflux of the stomach contents into the oesophagus is a common condition and classically in infants presents as recurrent non-bilious vomiting. Infants usually continue to gain weight unless the reflux is severe. Infants with reflux can also be very irritable with feeding and can refuse feeds. GOR can also cause respiratory symptoms with chronic cough, wheeze and aspiration. In severe reflux the infants can stop breathing due to laryngospasm causing ALTEs. GOR is also found in association with other respiratory conditions, such as asthma and CF and if found, is treated, but unfortunately does not always improve the respiratory symptoms. Children with severe cerebral palsy can also have significant problems with GOR and are also more prone to chest problems due to muscle hypotonia and ineffective cough.

### **Diagnosis**

This is based on the clinical history and examination of findings. Oesophageal pH monitoring and a barium swallow are also used. If there is a suggestion that a child has difficulty in swallowing then barium swallow and/or an upper GI endoscopy is indicated.

### **Treatment**

Simple reflux treatment in infants includes elevating the infants head in bed by placing a blanket or similar underneath the mattress. Feed thickeners, such as carobel can also be used. Infant Gaviscon sachets can also be added to feed to reduce acidity. Hydrogen blockers, e.g. ranitidine and proton pump inhibitors, e.g. omeprazole are also used. Domperidone a dopamine antagonist that stimulates gastric emptying and low dose erythromycin can also be used to stimulate gastric motility.

Severe cases are unresponsive to medical management may require surgical intervention using the Nissen Fundoplication procedure where the fundus of the stomach is wrapped around the lower oesophagus, strengthening the lower oesophageal sphincter.

## **ASPIRATION PNEUMONIA**

This is a condition where the contents of the pharynx or oesophagus spillover into the larynx and bronchial tree causing cough, fever and irritant pneumonias. This can occur

previously in normal children who have a reduced conscious level and can therefore not protect their own airway by coughing and closing their larynx, e.g. those with a head injury or coma from any cause. More often it is seen in children with chronic neurological conditions, e.g. cerebral palsy. GOR where the stomach contents reflux back into the oesophagus can also predispose to aspiration, particularly in the significantly neurologically handicapped children.

It can present in a child who coughs and chokes during feeds, but it can also occur silently until enough aspiration has occurred to cause symptoms of chronic cough, breathlessness and fever. It should be suspected in neurologically handicapped children who have reduced muscle power and developmental delay who present with recurrent severe chest infections. Recurrent aspiration can cause severe chronic lung disease.

### **Investigation of Aspiration Pneumonia**

This can be difficult. A CXR can show changes of aspiration, but these are often nonspecific. Often in aspiration the right lung is worst affected. A barium swallow or a pH study can be done to look for reflux. A videofluoroscopy where screening is done when the child is eating and drinking is very helpful and can show direct aspiration of the swallowed foods.

### **Management of Aspiration Pneumonia**

The acute treatment is to manage the chest infection with antibiotics, chest physiotherapy and oxygen, if needed. GOR should be treated. Consideration should be given to gastrostomy tube placement in children with cerebral palsy, with feeding difficulties, who have recurrent aspiration pneumonia.

## **ASTHMA**

Asthma is one of the commonest chronic conditions affecting children. In some studies nearly one in four children has had a diagnosis of asthma. Asthma increased in prevalence in the 1980s and 1990s, but is now showing signs of decreasing in prevalence. It causes significant morbidity. There are still asthma deaths in childhood. Asthma is a chronic inflammatory condition of the airways where there is mast cell activation and infiltration of inflammatory cells, e.g. eosinophils, airway macrophages, neutrophils, lymphocytes—usually TH<sub>2</sub> and interleukins. These cause oedema of the airways, disruption of the epithelium and mucus hypersecretion. There is reversible airways obstruction due to smooth muscle constriction in response to various trigger factors. This leads to the clinical symptoms of wheeze, nocturnal cough and difficulty in breathing—a child sometimes will complain of chest tightness or chest pains.



The most common trigger in childhood is viral URTIs. Other common precipitating factors include—exercise, emotion, cold weather and smoking. Children with asthma may have other atopic conditions, such as, hay fever and eczema. Atopy involves the capacity to produce IgE in response to common environmental proteins, such as house dust mite, grass pollen and food allergens. There is often a family history of atopy. There is ongoing research into genetic causes of asthma—the most investigated location for atopy has been the 5q 31–33 region of the chromosome, which includes the genes for the cytokines IL-4, -5, -9 and -13.

The diagnosis of asthma is a clinical one based on history taking and examination. It can be difficult to diagnose in young children. Some children can have recurrent virus induced wheeze, but no symptoms in between. There is a constant debate as to whether this is asthma or not or whether they are two ends of the same spectrum of disease. It can be difficult to separate out, and sometimes a trial of a preventer is appropriate, if attacks are frequent. Additional tests can help, such as, peak flow measurement (in over 5 years age group), lung function testing with reversibility and histamine challenge, exercise testing to see whether the bronchospasm can be induced, and skin tests to be checked for common allergens.

### Examination Findings

During an acute asthma episode the child shows the signs of respiratory distress depending on the severity of the attack. These include tachypnoea, hyperinflation, and sub-costal recession, and tracheal tug, use of accessory muscles of respiration. If severe, the child may be hypoxic or confused. On auscultation there is usually wheeze, which is often bilateral and reduced air entry. Crackles can also be heard. The child with severe acute asthma may have a silent chest. Routine chest radiographs are usually not needed in asthma; however, they usually show marked hyperinflation (Fig. 6.12).

Severe chronic asthma can lead to chest deformity of the lower part of the chest, i.e. Harrison sulci and/or a barrel-shaped chest. Children with asthma can have normal peak expiratory flow rates (PEFRs) and normal spirometry when well; however, some with very severe chronic disease can have obstructive changes on their spirometry, i.e. significant reduction in forced expiratory volume in one second (FEV1) with only some or no reduction in their forced vital capacity (FVC) (see Fig. 6.2). Often children with asthma may then demonstrate an increase in their FEV1 when they are given a bronchodilator, such as salbutamol. If a child with recurrent respiratory symptoms has finger-clubbing then further investigations are needed.



Fig. 6.12: Acute severe asthma with marked hyperinflation

Finger-clubbing in children can be associated with chronic suppurative lung conditions, such as CF and bronchiectasis.

### Asthma Management

The management of acute and chronic asthma depends on the severity of the symptoms and will be discussed in detail later. The aim of asthma management is for the child to have no asthma symptoms, to be able to lead a normal life, to have normal lung function, and not to need frequent rescue medication. It is very difficult to achieve this concept of total control in some children and for many parents and doctors the aim is to achieve as good asthma control as possible while weighing up the potential side effects of the treatment. The British Thoracic Society has evidence-based guidelines on the management of asthma which were updated in 2009 ([www.brit-thoracic.org.uk](http://www.brit-thoracic.org.uk)). There is strong support for asthmatics, their caregivers and professionals from various lung charities, e.g. Asthma UK ([www.asthma.org.uk](http://www.asthma.org.uk)) and the British Lung Foundation ([www.lunguk.org](http://www.lunguk.org)).

### Education and Management Plans

The key to good asthma management is education. This should include education of the parents and of the child, if they are old enough. Parents need to know the early warning signs, such as runny nose, cough, dark circles under their child's eyes progressing to the classical symptoms of persistent coughing, wheezing and difficult breathing. Often, if you ask parents they will tell you exactly what they notice when their



Fig. 6.13: Child asthma management plan for 18-month-old child (Courtesy: The asthma management plans from the Asthma and Respiratory Foundation of New Zealand)

child is becoming unwell. Asthma management plans are very useful particularly in the management of asthma attacks (Fig. 6.13). They document a child's individual symptoms and signs of their asthma, what their medication is, when to give it and when to call for help.

Parents who smoke should be given stopping smoking advice. Asthma education should occur in general practice and in hospital. It is important that nurses, doctors and allied health professionals, in fact all professionals, looking after children with asthma, have asthma education. Many hospitals and general practices in the UK have nurses with a special interest in paediatric asthma. Their role is very important in helping parents and children cope with their asthma.

Advice is also given about minimising exposure to other allergens for example the house dust mite. An example of author's asthma education leaflet is shown in the Figure 6.14. Electronic interactive asthma education packages are available.

### Drug Treatment of Asthma

Inhalers are the main form of treatment for asthma. In children these are usually metered dose inhalers given using a spacer device (Fig. 6.15). Dry powder devices that are activated by

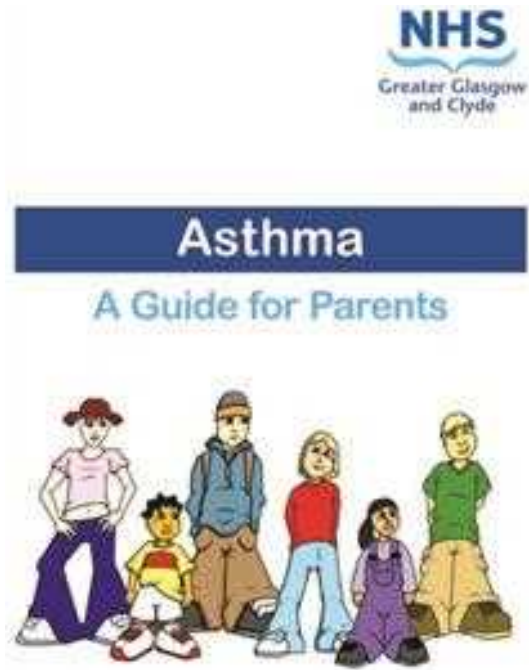


Fig. 6.14: Asthma—a guide for parents



Fig. 6.15: Volumatic with metered dose inhaler

sucking, such as, turbahalers and accuhalers can be useful in children over 8 years of age. The ability of parents and children to use their inhalers needs to be checked. Also, it is well recognised that compliance or adherence with treatment is a significant problem in many chronic diseases and many people would just tend to take their asthma treatment when they felt unwell instead of in a preventative way.

Children with mild intermittent asthma symptoms (step 1 of British Thoracic Society guidelines) require a short acting inhaled beta agonists, e.g. Salbutamol as required. This provides rapid relief for bronchospasm, and is used on as needed basis.

Children with more persistent asthma symptoms (step 2) should be treated with an inhaled steroid, e.g. clenil modulite or fluticasone dipropionate at as low a dose as possible to maintain symptom control, e.g. 100 mcg twice daily. Children need to wash their mouths out afterwards to reduce further absorption of the steroid from the mouth. In children, less than 5 years who are unable to take inhaled steroids then a leukotriene receptor antagonist is a suitable replacement for inhaled steroids.

Children with moderate asthma symptoms, not controlled on low dose inhaled steroids (step 3) can have their dose of inhaled steroids increased to 200 mcg twice daily of beclomethasone or equivalent. A long acting beta 2 agonist, e.g. salmeterol or formoterol or a leukotriene receptor antagonist, e.g. montelukast can also be tried.

Step 4 of the guidelines suggests that, if asthma control is inadequate with inhaled steroids (children: 400 mcg/day) plus long-acting B<sub>2</sub> agonist, then consideration should be given to increasing the inhaled steroid dose to 800 mcg/day, adding a leukotriene receptor antagonist and oral theophylline. If children fail to improve, then the drug should be stopped and the child referred to a specialist care. If increasing the dose of inhaled steroid has not helped, then this should be put back down to its previous dose. Some children may need high dose of inhaled steroids to keep their asthma under control. They are at increased risk of systemic absorption of the steroids, which can cause suppression of the adrenal glands and adrenal insufficiency. They should have a Synacthen test performed and a management plan discussed with the parents and their own doctor as what to do, if their child became unwell. These children would be at risk of adrenal crises with hypoglycaemia, coma and death.

If asthma symptoms persist and children are having frequent exacerbations, the next step is daily oral steroids. This can have significant side effects, e.g. weight gain and immune suppression. Prior to starting this, many children will have further investigations to try to make sure that this is difficult to control asthma and not another problem, such as, CF or GOR. Other medications for difficult asthma include subcutaneous bricanyl infusions, anti-IgE antibody

therapy, such as omalizumab, which binds free serum IgE, and therefore is thought to interrupt signals earlier in the allergy pathway that leads to asthma. Immunosuppressives such as cyclosporin or methotrexate are also occasionally used in severe asthma.

In the children under 5 years of age the management of asthma is somewhat different as there is more evidence for the effectiveness of montelukast. It should be tried in addition to low dose inhaled steroids before long acting beta agonists. Young children with difficult asthma symptoms should be referred for further investigation and management.

### Management of Acute Asthma Attack

This very much depends on the severity of the attack. The child needs to be assessed quickly and efficiently. There are courses run worldwide by resuscitation organisations, e.g. the advanced paediatric life support course run by the Advance Life Support Group ([www.alsg.org](http://www.alsg.org)). These provide an excellent way to learn to manage paediatric emergencies.

The approach is based on assessment of airway, breathing and circulation. Is the child's airway open? What is their work of breathing? What is their circulation (normal skin colour, capillary refill time less than 2 seconds)?

A child who is alert, talking easily with a normal respiratory rate is less concerning than a child who is too breathless to talk, has significantly increased work of breathing, and who appears confused or looks exhausted and pale.

The following should be considered in a child with acute asthma episode:

1. Assess and manage: airway, breathing and circulation—if unwell with respiratory distress start high flow oxygen.
2. Check oxygen saturation level, and if less than 94% start oxygen.
3. If over 5 years of age and if able to check peak flow—if less than 50% this is a moderately severe attack, if less than 33% of normal this is a life-threatening exacerbation.
4. Give salbutamol 10 puffs via a spacer device—this is called multidosing and this can be repeated half hourly until benefit seen. Arterial blood gases are not routinely performed in acute asthma—they can cause further distress. Capillary blood gases can be done in those causing concern, they will give a useful CO<sub>2</sub> level.
5. Children with severe distress, who cannot multidose, should be given nebulised salbutamol (2.5 mg in those under 5 years and 5 mg in those over 5 years). The nebuliser can be given continuously in severe attacks.
6. Give oral prednisolone 2 mg/kg per day up to maximum of 40 mg per day.
7. Reassess—if child is not improving or getting worse obtain intravenous access, start IV hydrocortisone. Consider

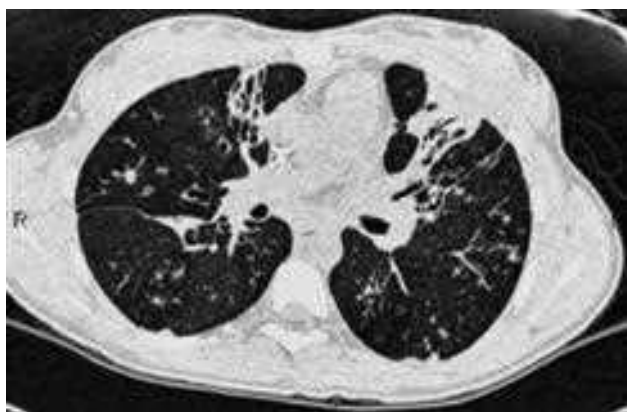
IV aminophylline infusion—bolus should be given, if child not on theophylline. Intravenous salbutamol and IV magnesium can also be added for severe attacks. Paediatric centres vary in their first choice of IV treatment for asthma.

Unwell children should be moved to a high dependency area if available, for close observation and cardiac monitoring. If children with life-threatening asthma deteriorate despite these measures with increasing CO<sub>2</sub> levels and increasing oxygen requirement then non-invasive ventilator support can be given by way of a face mask and either continuous positive airway pressure (CPAP) or bi-level positive airway pressure (BiPAP) ventilator support where both inspiration and expiration are supported by the ventilator. Very rarely do children need invasively ventilated for asthma. Indications for this would be respiratory failure not responding to all other measures and respiratory arrest. As with many other causes of arrest in children out of hospital arrests have a very poor prognosis. Most children respond well to multidosing with salbutamol, oxygen and steroids.

## BRONCHIECTASIS

Bronchiectasis is a condition where the bronchi are irregularly shaped and dilated (Fig. 6.16). Pulmonary secretions do not drain properly and are prone to infection. This causes further inflammation and scarring with airways obstruction. This causes chronic cough and sputum production. Recurrent exacerbations can occur that causing breathlessness and significant morbidity with loss of lung function due to obstructive lung disease.

Congenital bronchiectasis is rare. Most are acquired from genetic conditions such as CF, primary ciliary dyskinesia (PCD) and immunodeficiency syndromes. Post-infectious bronchiectasis can occur following pneumonia, measles or whooping cough. It can also occur secondary to recurrent aspiration or to foreign body aspiration. It is important to try



**Fig. 6.16:** Computed tomography scan showing severe bilateral bronchiectasis

to establish the underlying reason for the bronchiectasis to prevent further damage.

The clinical features of bronchiectasis include finger-clubbing and chest deformity. Any child with bronchiectasis needs investigations to try to find and treat the cause. The mainstay of treatment is chest physiotherapy and prompts treatment of exacerbations with antibiotics. Sputum cultures aid in choice of antibiotics. There are guidelines available for the management of non-CF related bronchiectasis in children and adults. ([www.brit-thoracic.org.uk](http://www.brit-thoracic.org.uk))

## CYSTIC FIBROSIS

Cystic fibrosis (CF) a very common genetic condition in Caucasians. In UK, the carrier rate is approximately 1 in 25. It is rare in the African-American population, but is found in the Asian population particularly those of Pakistani and Indian origin. It has autosomal recessive inheritance caused by mutations on the CF gene, which is located on the long arm of chromosome 7. There are over 1,500 causative mutations of CF, the most common one being Delta F508 mutation. The mutations are found in the gene which codes for a protein—the cystic fibrosis transmembrane regulator (CFTR) protein which is made up of 1,480 amino acids. This protein is a chloride channel regulator, an ABC (ATP-binding cassette) transporter or traffic ATPase. It is involved in the transportation of molecules, such as chloride across the membranes of cells in the lungs, liver, pancreas, digestive tract, reproductive tract and skin. Mutations in it cause defects in salt and water absorption across cells.

The Delta F508 mutation is a deletion of phenylalanine at residue 508, this leads to a misfolding of the CFTR protein, and when it reaches the endoplasmic reticulum of the cell it is marked as faulty, and is then degraded and does not reach the cell membrane to perform the role it needs to. There are 5 main classes of severity of CF mutations (Fig. 6.17). They can result in different problems with CFTR function from

**Class 1:** G542X, W1282X, 1078 DELTA T, 621+1G-t, R553X

**Class 2:** DF508, S549N

**Class 3:** G551D, R560T

**Class 4:** R117H, G85E, R347P

**Class 5:** 3849+10kbC-T

**Fig. 6.17:** Different classes of cystic fibrosis mutations

Class 1 nonsense mutations causing the CFTR protein not to be made properly in the first instance, to the CFTR being made properly, but not transported to the cell membrane where it is needed. Individuals who are homozygotes with Class 1 or Class 2 mutations are associated with more severe disease. The Delta F508 mutation is a Class 2 mutation.

The different combinations of mutations lead to different levels of functioning CFTR protein. Classic CF disease with failure to thrive, severe bronchiectasis and pancreatic insufficiency is usually only clinically apparent where the levels of CFTR protein are extremely low. The parts of the body, which are most reliant on the functioning of the CFTR protein, are the vas deferens, the pancreas, lungs and bowel. Interestingly there are other genes called “disease modifiers”, and they are thought to explain the findings that you can have 2 children from the same family with the same CF mutations who can have significantly different disease severity.

### Presentation of Cystic Fibrosis

“Mild CF” may only present in adulthood with male infertility and sinusitis whereas “Classic CF” presents in childhood with recurrent chest infections, malabsorption and failure to thrive due to pancreatic exocrine insufficiency.

CF should be suspected in children with frequent chest infections, particularly those with diarrhoea and poor growth. Finger-clubbing may be present as well as chest deformity, crackles and wheeze. Abdominal distension and malabsorptive signs should also prompt further investigation.

CF can also present as neonatal gut obstruction where the bowel is obstructed by inspissated meconium. This causes small bowel obstruction and can be associated with micro colon (Fig. 6.18). The small bowel distension can



Fig. 6.18: Bowel obstruction due to meconium ileus

be detected on antenatal ultrasound. The affected bowel can be necrotic and frequently affected bowel is resected and stomas created, and then reconnected when the bowel has healed. Bowel dysfunction is common and it can take some time for the bowel to absorb feeds normally. Specialist input from dietitians and gastroenterology is needed as these babies can require TPN for several months until their bowel recovers.

### Screening for Cystic Fibrosis

In some countries where CF is common, such as Australia and the UK neonatal screening has been introduced. The process is based on measuring the immunoreactive trypsin level (IRT) in the newborn screening blood spot which is taken at day 5 of life. If the IRT level is significantly elevated then the blood is sent for genetic analysis for varying numbers of CF mutations depending on the country. If the baby is found to have CF it has been shown that earlier diagnosis leads to a better prognosis with respect to better weight in the screened individuals.

### Cystic Fibrosis Diagnosis

The gold standard for the diagnosis of CF is the sweat test. This involves obtaining a sample of sweat induced by pilocarpine iontophoresis and measuring the amount of sodium and chloride present. In children a sweat chloride concentration over 60 mmol/kg is diagnostic of CF. However, false positive and false negative sweat tests do occur and usually 2 or 3 sweat tests are done. If the sweat test is positive then the child’s blood is sent for CF gene mutation analysis.

Additional tests that can help include measurement of the faecal fat, which is often increased in malabsorption, and measuring faecal chymotrypsin levels which are low.

### Disease Progression

Cystic fibrosis is a life-shortening disease with no cure. Many treatments are available which help to improve life expectancy and now the average life expectancy of a child born today with CF is to the late 30s or early 40s. The morbidity and mortality comes from the tenacious respiratory secretions, lung infection and inflammation. These cause repeated infections and inflammation further cause destruction of the airways with obstruction and bronchiectasis (Fig. 6.19). Ultimately this causes respiratory failure. Such children should be considered for referral for double lung transplant. However, this is not without risk and consideration needs to be taken of what organisms the child recurrently cultures from their sputum, whether the child is significantly underweight and how well patients and their parents comply with treatment. Unfortunately there is a significant shortage of organs, particularly for children so many on the transplant



**Fig. 6.19:** Severe cystic fibrosis lung disease with hyperinflation, central peribronchial thickening and bronchiectasis

list die before they can be transplanted. Transplantation itself has a significant morbidity and mortality and transplanted organs have a limited life span therefore the goal of CF treatment is to maintain good nutrition and preserve lung function. CF researchers continue to look for new therapies and potential cures, e.g. gene therapy to try to replace the defective gene ([www.cfgenetherapy.org.uk](http://www.cfgenetherapy.org.uk)), drugs which target specific CF mutations, e.g. vertex 770 and drugs to alter the osmolarity of the mucus, e.g. mannitol. There is a detailed list of the upcoming therapies on the Cystic Fibrosis Foundation website ([www.cff.org](http://www.cff.org)).

There are several charitable organisations worldwide for CF which has valuable information on their websites both for parents and for healthcare professionals. ([www.cftrust.org.uk](http://www.cftrust.org.uk), [www.cff.org](http://www.cff.org)).

### Common Respiratory Pathogens in Cystic Fibrosis

The CF lung is susceptible to infection and damage from a number of organisms. These include *S. aureus*, *Pseudomonas aeruginosa*, *H. influenzae* and *Burkholderia cepacia*. UK centres have most children on prophylactic anti-staphylococcal antibiotics for at least the first 2 years of their lives. *P. aeruginosa* and *B. cepacia* are organisms that are ubiquitous in the environment. *P. aeruginosa* colonisation, where *Pseudomonas* is recurrently isolated from cough swabs or sputum has been shown to adversely affect the outcome in CF. If *Pseudomonas* is isolated, even if a child is well, eradication measures are started including oral, nebulised and intravenous antipseudomonal antibiotics. This is an attempt to prevent colonisation with *P. aeruginosa*. Epidemic subtypes of the *B.cepacia* organism have caused significant increased mortality. Many centres are now segregating both

inpatients and outpatients with CF to try to reduce the spread of organisms.

### Management of Cystic Fibrosis

This is multidisciplinary and involves specialist physiotherapists, dieticians, dedicated nursing, medical and surgical staff, social workers, psychologists, pulmonary physiologists and geneticists. The cornerstones of therapy are chest physiotherapy, nutritional support, and prophylactic antibiotics and prompt antibiotic treatment of increased respiratory symptoms.

### Physiotherapy

Physiotherapy in CF has two main goals: the first being secretion clearance and the second being improving overall fitness. Various techniques are used, such as the use of PEP masks; flutter devices and activated cycle of breathing techniques. Chest percussion and drainage are still used in some centres.

Chest physiotherapy should be performed one to three times daily depending on the individual and their state of health. Daily activity is encouraged in children and should be as fun as possible, e.g. use of trampoline, and participation in school sports and team games.

### Nutrition

The aim of nutrition in CF is to achieve normal growth. This can be difficult in CF due to the combination of pancreatic insufficiency and the fact that recurrent infections lead to poor appetite and increased basal metabolic rate. Normal growth has been shown to improve lung function and survival in CF. Usually for this to occur the child's intake often needs to be more than a child of their age would normally have. This can mean larger portions and consumption of foods higher in calories. In children who are pancreatic insufficient, pancreatic enzymes need to be given with all meals and most snacks to help with food digestion and absorption. Malabsorption can still occur despite pancreatic enzymes. Other medications, e.g. ranitidine, can be added to their treatment to try to reduce gastric acidity and improve the functioning of the enzymes. Children may need calorie supplements and also occasionally gastrostomy feeding. Children with advanced lung disease can continue to lose weight despite all of these measures. Fat soluble vitamins—Vitamins A, D and E are given daily usually in multivitamin preparations.

### Antibiotics

In the UK prophylactic antibiotics are given usually against *Staphylococcus aureus*, e.g. flucloxacillin. Mild

pulmonary exacerbations are treated with additional oral antibiotics. Moderate to severe exacerbations are managed with intravenous antibiotics usually with two drugs, e.g. ceftazidime and tobramycin, which are active against *Pseudomonas* as well as a number of other bacteria for 2 weeks. Physiotherapy is also increased in frequency. Many parents can do some of the intravenous antibiotic therapy at home. Some children with difficult intravenous access require semi-permanent subcutaneous central venous access, e.g. Port-a-cath (Fig. 6.20). This allows frequent drug administration without repeated venepuncture. Nebulised antibiotics, e.g. “colomycin” and “TOBI (nebuliser solution, tobramycin)” are also used in eradication protocols for *P. aeruginosa* and in the treatment of patients who are chronically colonised with *P. aeruginosa*.

Azithromycin is also increasingly being used in patients with CF who recurrently grow *P. aeruginosa*. It has been shown in several studies to reduce the number of exacerbations. It is thought to have an anti-inflammatory effect.

### Other Cystic Fibrosis Therapies

Pulmozyme is a nebulised preparation that breaks down the DNA in respiratory secretion. In some patients it has reduced the number of CF exacerbations and has also been shown to increase lung function. Nebulised hypertonic saline has also been shown to help with sputum clearance and can be added into the treatment of a CF exacerbation.



**Fig. 6.20:** Advanced bronchiectasis in cystic fibrosis with a Port-a-cath

## Cystic Fibrosis Complications

### Cystic Fibrosis Gut Disease

Cystic fibrosis transmembrane regulator (CFTR) regulates chloride secretion in the gut. It also regulates ENaC (epithelia sodium channel), NHE3 (sodium hydrogen exchanger) and anion exchange. In CF this causes reduced and faulty intestinal secretions which leads to sticky mucus and faecal material in the intestine. Fat malabsorption also occurs despite appropriate enzyme dosage. There can also be faulty uptake of bile acids from the small intestine. All of these can cause constipation, and if the material impacts can cause distal intestinal obstruction syndrome (DIOS). This is a condition which presents similarly to meconium ileus in the newborn with CF where there is gut obstruction and often perforation due to abnormal meconium.

The treatment of constipation includes dietary interventions and laxatives, e.g. lactulose and movicol as well as checking that the child is taking his or her pancreatic enzymes the correct way. DIOS usually requires admission to hospital and further management with gastrografin. Occasionally surgery may be needed.

### Cystic Fibrosis Liver Disease

Focal biliary cirrhosis is the commonest form of liver disease in CF. It is often asymptomatic. Cirrhosis with portal hypertension is only reported in 2–3% of children with CF and 5% of adults. However, liver disease is the second most common cause of death. There is increased incidence in those who have had meconium ileus but otherwise it is unrelated to genotype. Liver disease is three times more common in boys. The pathogenesis of liver disease in CF is not entirely understood. It is thought to be due to defects in biliary chloride transport, leading to diminished bile salt production. The liver often has fatty infiltrates as well. Stasis and obstruction in the biliary tree then ensue. Also intrahepatic bile ducts are often abnormally narrow and gallbladder abnormalities are common. The diagnosis of liver disease is difficult as liver enzymes may only be mildly elevated. Annual liver ultrasounds are the best way of picking up early changes. The treatment includes ursodeoxycholic acid, attention to nutrition and vitamin K for those with abnormal coagulation studies.

### Cystic Fibrosis Related Diabetes

Again this is a rare complication in childhood but affects up to 30% of adults with CF. Untreated, it causes increased morbidity and mortality. Its onset is often insidious and it needs to be thought of in a child who is not doing well and losing weight for no apparent reason. Its exact pathogenesis is not understood, but there is fibrosis and fatty infiltration of the pancreas with resulting loss of islet cells. However,

there are people with CF who appear to have similar levels of pancreatic damage but one is diabetic and one is not. There is, therefore, thought to be an additional genetic predisposition. Insulin is used in the management of cystic fibrosis related diabetes (CFRD).

### Primary Ciliary Dyskinesia

The respiratory tract is lined by ciliated mucosa. Mucociliary clearance plays an important role in defending the lungs against bacteria. PCD is a rare autosomal recessive condition in which the cilia beat abnormally and are structurally defective. This results in abnormal mucus clearance that causes frequent chest infections with chronic cough and bronchiectasis. Males are usually infertile. Ear infections are common. Kartagener first described it in 1933 as a syndrome of bronchiectasis, situs inversus (where the heart and abdominal organs are located on the opposite sides of the body to normal) and sinusitis. The diagnosis is made by biopsy of the nasal mucosa and the material analysed for ciliary movement and structure. Treatment of this condition includes chest physiotherapy and prompt treatment of infections with antibiotics.

### PULMONARY TUBERCULOSIS

Tuberculosis (TB) is caused by infection with *Mycobacterium tuberculosis*. TB is most common in the developing countries of the world and is sustained in areas of poverty and deprivation. TB notifications steadily decreased in the 20th century but have not decreased in the past decade. Significant cause of morbidity and mortality has worldwide.

In children the infection is spread from an adult who is infected and so-called "sputum positive", i.e. has *Mycobacterium* in their sputum. Children are rarely contagious as they rarely expectorate infected sputum. Spread is more common with close household or school contacts. Pulmonary TB is caught by inhaling respiratory secretions from an infected person when they cough or sneeze. The bacteria then grow over several weeks and stimulate the immune system as the body tries to kill the bacteria. In about one-fifth of infected individuals this process is not effective and the bacteria remain in a latent form. The *M. tuberculosis* can reactivate at any time leading to TB disease. Pulmonary TB disease causes cough, night sweats and weight loss. Full Guidelines for the management of TB can be found at [www.nice.org.uk](http://www.nice.org.uk).

All children who are known contacts of someone with sputum positive TB should be seen and have a mantoux and CXR performed. Blood tests for TB are based on detecting tuberculous antigens, e.g. early secreted antigen target-6 (ESAT-6) and culture filtrate protein-10 (CFP-10).

Children with positive mantoux test and CXR changes are usually admitted for 3 early morning gastric washings. This is the best way of obtaining an organism in a child. Young children are particularly at risk of TB meningitis. Rifampicin, isoniazid, pyrazinamide and ethambutol are common drugs used in TB. They are used in combination usually three drugs for 2 months and then rifampicin and isoniazid are continued for a further 4 months. In parts of the world where resistance to these drugs is a problem then other agents, e.g. streptomycin is used. Close follow-up is needed and frequently children are put on directly observed therapy or "DOTS" where nursing staff observe the therapy being given three times a week.

### BRONCHIOLITIS OBLITERANS

Bronchiolitis obliterans is rare in children. It is a result of an injury to the bronchioles and smaller airways. Repair of this leads to excessive granulation tissue that block airways. The airways then become obliterated by nodular masses of granulation and fibrosis.

In children the majority of cases are post-infectious, e.g. adenovirus 3, 7 and 21, measles, influenza, mycoplasma and pertussis. It can also occur in post-lung transplant. In many no obvious injury can be found. The symptoms of bronchiolitis are usually persistence of cough, wheeze and breathlessness following viral like illness. Affected children usually have persisting wheeze and crackles on auscultation. They can have significant hypoxia with cyanosis. It can also cause bronchiectasis and chronic respiratory failure.

The chest radiograph findings vary from normal to areas of hyperlucency, hyperinflation, to bronchial wall thickening consolidation and bronchiectasis. The changes may be bilateral or unilateral. The diagnosis of bronchiolitis obliterans relies on high-resolution chest CT scan where areas of hyper-aeration, mosaic ground glass appearance and bronchial wall thickening are seen. The treatment of bronchiolitis obliterans in children is difficult. In some cases prednisolone has been used and appears to be of benefit. Other reports suggest spontaneous remission. Some children still die of respiratory failure. Poor prognostic factors are age; children who are older do worse, atopy and also those who present in the winter. The reasons for these differences are not known.

### PNEUMOTHORAX

Air in the pleural space is called pneumothorax. A tension pneumothorax is one where the air collection gets larger with each breath and causes mediastinal shift to the opposite side of the chest. The clinical signs of this are hyper-resonance and decreased air entry on the affected side with tracheal shift to



the opposite side. This is a life-threatening emergency, which requires immediate resuscitation and needle decompression by placement of an intravenous cannula in the second intercostal space in the midclavicular line on the affected side. A formal chest drain connected to an underwater seal should then be inserted usually in the 5th intercostal space in the midaxillary line on the affected side.

Rarely, spontaneous pneumothoraces do occur and they can be associated with chest pain on the affected side and breathlessness. Some of these may be due to rupture of previously undiagnosed congenital lung bullae. Small pneumothoraces do not need drained, as many will resolve spontaneously.

Most pneumothoraces in children are secondary to other problems. They can occur secondary to chest trauma, acute severe pneumonia, CF, as a complication of chest drain insertion for pleural effusion or central line insertion or to foreign body inhalation. The CXR (Fig. 6.21) shows the appearance of a pneumothorax with the loss of lung markings and free air round the lung. In some severe pneumonic processes the pleural air can actually be in pockets around the lung and sometimes more than one chest drain is needed.

### SLEEP DISORDERED BREATHING IN CHILDREN

Sleep disordered breathing is increasingly recognised in children. When asleep the normal child's breathing control changes and there is reduced muscle tone in the intercostal muscles and the pharyngeal dilator muscles. This increases airways resistance. Children with adenotonsillar hypertrophy who can breathe satisfactorily when awake then develop significant obstruction to air flow when asleep. Hypoventilation can also occur when asleep, particularly in



Fig. 6.21: Severe pneumonia with a large right-sided pneumothorax in an intubated child

children with neuromuscular weakness. The most serious form of hypoventilation is congenital central hypoventilation syndrome (CCHS) where the infant's ventilatory drive is impaired, and when the infant falls asleep they stop breathing. This condition is fatal without treatment with ventilatory support.

### OBSTRUCTIVE SLEEP APNOEA

This is thought to affect 0.7–3% of children with the majority being under 5 years of age. It is thought to result from a combination of problems with ventilatory drive, neuromuscular control and anatomical factors. The classical features are loud snoring, pauses in breathing with gasping breaths at the end of an apnoea and abnormal chest movement. This is associated with partial awakening. Children with obstructive sleep apnoea (OSA) are often restless. The disturbed sleep leads to daytime sleepiness, irritability and poor concentration. Severe OSA in a young child can cause failure to thrive. An OSA in young children is usually due to adenotonsillar hypertrophy. Upper airway congenital abnormalities, e.g. craniofacial abnormalities can also cause OSA. Older children with OSA are often morbidly obese—either from eating too much or secondary to other conditions which cause excess weight gain. Conditions which cause hypotonia, e.g. cerebral palsy can also lead to airways collapse and obstruction during sleep.

Children with suspected OSA need clinical examination and further investigation. This can include an overnight oxygen saturation study which will document periods of hypoxia to full polysomnography where oxygen saturation levels, respiratory muscle movement, eye movements, airflow, heart rate and electroencephalography (EEG) are recorded.

Children whose OSA is due to adenotonsillar hypertrophy usually respond well to adenotonsillectomy. They start to sleep better and most of the behaviour and concentration problems improve. There are some concerns; however, that there may be lasting neurodevelopmental consequences. Children with underlying conditions and those obese children who fail to lose weight need further treatment. Untreated OSA with recurrent hypoxia and hypercapnia leads to hypertension, left ventricular hypertrophy, cor pulmonale and death. Pulmonary hypertension can also occur.

Treatment involves ventilatory support at night with non-invasive ventilation using either a nasal or face mask and a ventilator providing BiPAP support. This method gives additional pressure support to aid breathing in both inspiration and expiration. This is usually well tolerated in children and significantly improves sleep quality by correcting the hypoxia and hypercapnia. It can be difficult to institute in children with significant neurological handicap, particularly those with behaviour problems.

## NEUROMUSCULAR CAUSES OF SLEEP DISORDERED BREATHING

There are many neuromuscular disorders which cause sleep disordered breathing from a combination of either neurological insult, and severe muscle weakness or hypotonia, e.g. Down's syndrome, Duchenne's muscular dystrophy (DMD), spinal muscular atrophy, cerebral palsy, CCHS and children with impaired breathing following spinal cord damage. The treatment of these children is based on their individual needs and their prognosis from their underlying condition. In some of these conditions invasive ventilation via a tracheostomy tube is used. Young people with DMD will usually ultimately die from respiratory failure; however, non-invasive ventilation using BiPAP at night has been shown to improve life expectancy into the late teens and above in some of those affected.

## SUDDEN INFANT DEATH SYNDROME

This can be defined as the sudden unexpected death of an infant for which no apparent cause can be found despite careful investigation and post-mortem. It is the most common cause of post-neonatal infant death in the United States and Canada. The cause of sudden infant death syndrome (SIDS) is not understood; however, there are documented post-mortem findings, such as, evidence of low-grade asphyxia in the lungs and structural and neurotransmitter abnormalities in the brainstem. Recently there has been significant interest in serotonin which is abnormal in infants with SIDS. Serotonin is involved in the control of cardiac autonomic and respiratory function, as well as now being identified as abnormal in infants with SIDS. The incidence of cot death fell dramatically with the "back to sleep" campaign where evidence had shown that infants who were laid prone to sleep had an increased chance of SIDS so advice was given to lay all infants on their back. Maternal and antenatal risk factors include maternal smoking, alcohol use during pregnancy, illegal drug use and poverty. Infant risk factors include age—SIDS peaks at 2–4 months, male sex, prematurity and exposure to tobacco smoke. Losing an infant to SIDS can have devastating effects on families and there are several charities offering support and funding on ongoing research into SIDS, such as, the Foundation for the Study of Infant Deaths ([www.sids.org.uk](http://www.sids.org.uk)).

## CHEST INJURY

Chest trauma in children is rare and in younger children it is usually accidental, e.g. road traffic accident. In older children and teenagers deliberate violence, such as, stabbings and gunshot wounds, can cause significant injury. Children's

chest walls have increased elasticity in comparison to the adult bony thorax. They can sustain chest trauma with damage to internal thoracic organs without rib fractures. Therefore, if the history of the accident is such that significant force has been involved, then it should be assumed that there is underlying internal organ damage until proven otherwise. If the chest wall is significantly damaged, e.g. flail chest then this is tolerated less well in children in comparison to adults. Chest injuries seen in children include tension pneumothorax, open pneumothorax, haemothorax, pulmonary contusions and cardiac tamponade; flail chest and disruption of the great vessels. The priority in managing a child with trauma is establishment and protection of the airway; assessing breathing and dealing with life-threatening problems, e.g. needle decompression of tension pneumothorax and then assessing the circulation and giving fluid resuscitation. Children with significant trauma should have two large bore cannula inserted and blood should be taken for immediate cross-matching, so it is available when needed.

## FOREIGN BODY INHALATION

This is a fairly common problem in paediatrics, particularly in the preschool child. It occurs when a child accidentally inhales a foreign object, which is often food. Usually this leads to choking and coughing, which nearly always dislodges the object from the larynx and expels it. Children who fail to clear the object and who are choking and having difficulty breathing need urgent measures to clear the blockage—if the object is visible in the mouth it should be removed. If the child can cough they should be encouraged to cough. If the cough is ineffective and a child is conscious then a combination of back blows and abdominal thrusts and the Heimlich manoeuvre can be used in the older child. In young infants abdominal thrusts should not be used because of the possible damage to internal organs. Emergency help should be sought. In the unconscious child who has choked, airway opening manoeuvres should be performed, rescue breaths given and cardio-pulmonary resuscitation started, if there are no signs of improvement.

Smaller inhaled objects, e.g. peanuts can pass through the larynx and lodge in the trachea or one of the bronchi. This can lead to persistent coughing and on auscultation doctor may hear unilateral wheeze. A chest radiograph could show hyperinflation of one lung, caused by partial obstruction to the flow of air on that side, i.e. air can get into that lung, but not get out. However, the CXR can be normal. Peanuts are very irritating and can lead to a secondary pneumonia. If a child is suspected of foreign body inhalation then they require a rigid bronchoscopy to remove the offending object.

## QUESTIONS AND ANSWERS

### Questions

1. A 14-week-old baby presents with a one week history of intermittent stridor. She had been admitted twice previously and had been diagnosed as having croup and had been given oral steroids, which did appear to help. On examination she was alert and had marked inspiratory stridor with mildly increased work of breathing, her oxygen saturation was 98% in air. What further investigations does she need?
2. What pattern of lung disease do the following lung function results suggest? What two diseases could result in this picture?
 

FEV1	1.35 predicted 1.80
FVC	1.90 predicted 1.86
TLC	3.0 predicted 2.76
RV/TLC	40% predicted 24%
3. A 2-year-old boy is admitted to the surgical wards with his fourth rectal prolapse. He is thriving with weight on the 50th centile and height on the 50th centile. He has a very good appetite and eats as much as his 5-year-old brother. He passes 2–3 pale loose stools per day. He has an occasional cough. His full blood count and urea and electrolytes are normal. What investigations are needed?
4. A 5-year-old boy is admitted with a severe choking episode requiring resuscitation. He recovers well. However, he had a history of recurrently choking with feeds from early infancy. At 6 months of age, he had a CXR and barium swallow which were normal. He was allowed home and apart from one admission with croup was not unwell enough to require admission. His parents reported that the choking with fluids had been an ongoing problem. He is thriving and had no problems swallowing. What other investigations does he need? What is the management of this condition?
5. A 2-month-old baby girl is admitted with 2 days of nasal discharge, cough and difficulty feeding. On examination her temperature is 37.9°C, her respiratory rate is 60, she has moderate sub-costal recession and crackles evident bilaterally. Her oxygen saturation is 89%. What is the most likely diagnosis? What would your management be? What investigations are needed?
6. A 12-year-old girl is admitted with several days of cough and fever. An X-ray shows partial left lower lobe pneumonia. As she is systemically well she is commenced on oral antibiotics and is allowed for home. Four days later she

is readmitted with recurrence of fever and difficulty in breathing. There is decreased air entry at the left base.

What further investigations would you do?

Her white cell count is 25; her urea and electrolytes are normal. Her CXR shows a large left-sided effusion.

What investigation would you do next?

What is the management now?

7. A 12-year-old boy is referred with chest tightness on exercise and breathlessness. His asthma control had previously been well controlled on flixotide 250 mcg twice daily via spacer and ventolin as needed. His inhaler technique is good and you are fairly certain he takes his inhalers! What treatment would you add?
8. A 5-year-old girl is reviewed as an emergency with an exacerbation of asthma. She is breathless, wheezy and pale. What treatment is required?
9. A 2-year-old girl presents with significant difficulty in breathing during sleep. On examination she has noisy nasal breathing when awake with increased respiratory effort and pectus excavatum. Apart from transmitted upper airways noise her chest is clear. What further clinical sign should be looked for? What investigations are needed? What treatment may be required?

### Answers

1. This baby should have barium swallow performed to look for a vascular ring. If this is negative then she should have a bronchoscopy performed to rule out the presence of an anatomical abnormality of her airway or laryngeal haemangiomas.
2. The results suggest an obstructive lung disease pattern, such as, that caused by severe asthma or CF.
3. With the history given the possibility of CF needs to be investigated, e.g. child needs a sweat test in the first instance.
4. He requires a bronchoscopy to look for a TOF. The management of this is surgical repair of the fistula. This is a real case and postoperatively the child remained well with no cough.
5. The most likely diagnosis is bronchiolitis. The management is to give oxygen, start NG feeds or IV fluids and obtain an NPA for virology. This baby requires close observation of temperature, pulse and respiratory rate and oxygen saturation
6. Initial investigations would be FBC, blood cultures, electrolytes and CXR. The abnormal CXR should be followed by chest ultrasound to assess the amount of effusion present. The management would be insertion of

- a chest drain under general anaesthetic and consideration of instillation of a fibrinolytic agent, e.g. Urokinase.
7. There are several options here—you could add in an inhaled long acting beta agonist, start a combination preparation of an inhaled steroid and a long acting beta agonist or add a leukotriene receptor antagonist.
  8. Give oxygen, multi-dose with ventolin 10 puffs via spacer and repeat as needed depending on patient response. Give oral prednisolone 2 mg/kg up to max of 40 mg per day.
  9. Doctor should examine for adenotonsillar hypertrophy which is likely the commonest cause of her symptoms.

This child needs baseline oxygen saturation studies done and an overnight saturation study. If this confirms OSA then she requires adenotonsillectomy. If the sleep apnoea is severe then she will need a bed in the paediatric intensive care unit postoperatively. If the overnight saturation study is not diagnostic then polysomnography is indicated.

---

### ACKNOWLEDGEMENTS

Many thanks to the radiology staff at Yorkhill hospital for the images provided.

# Gastroenterology and Hepatology

## GASTROINTESTINAL AND LIVER DISEASE

### INTRODUCTION

The alimentary tract is a complicated viscous extending from the mouth to the anus with structural differentiation and adaptation according to the specific function needed. The oesophagus is a passage from the pharynx to the stomach, where digestion begins. Food then moves into the small intestine, where further digestion and absorption occurs. The large intestine reabsorbs 95% of water and completes absorption of digested products leaving the residue to be expelled intermittently from the rectum.

The most common signs of alimentary tract disorders are vomiting, abdominal distension and disorders of defaecation. In the older infant and child, abdominal pain becomes the most common symptom indicating dysfunction of the gut and requires investigation of its cause. An adequate history from the parents and child is most helpful in arriving at the correct diagnosis, and this may be followed by examination and investigations. Many of the causes of abdominal pain are discussed later in the differential diagnosis of acute appendicitis. Most newborn babies vomit a few times in the first week of life. A small quantity of milk is often regurgitated when wind is “broken” during or after feeding. Persistent vomiting and vomiting in the older child is usually a significant sign and may be associated with a wide variety of pathological conditions. Infections of the alimentary tract such as gastroenteritis result in the infant or child presenting with vomiting, which is also a common non-specific sign in other infections, e.g. meningitis, urinary tract infection or septicaemia. Vomiting is the most consistent sign of intestinal obstruction in the newborn. It usually starts in the first day of life and becomes progressively more frequent. The vomit usually contains bile, as it is rare for the obstruction to be above the ampulla of Vater. Bile-stained vomiting in the absence of an organic cause is rare, and infants and children with bile-stained vomit should be investigated in hospital.

Normal infants should pass meconium within 24 hours of birth. Delay to do so or failure to pass meconium is an important sign, which should not be overlooked. Failure to pass meconium may be due to an organic obstruction but subsequent passage may be a sign of disease such as hypothyroidism or Hirschsprung’s disease.

The infant normally settles into a pattern of having one, two or more bowel actions daily but in diarrhoea, increased frequency of passage of stools which become more liquid or constipation are presenting signs of a variety of disorders. In the early stages of intestinal obstruction, there may be little abdominal distension, and any such distension may be difficult to distinguish from the naturally protuberant abdomen of the newborn. Visible loops of bowel and peristalsis are abnormal in the term or older infant, but in the thin-walled premature infant may not be indicative of obstruction. For surgical paediatric problems, discussed in Chapters 10 (Neonatal Surgery) and 11 (General Paediatric Surgery).

#### Key Learning Point

- ▶ Bile-stained vomiting in the absence of an organic cause is a rare symptom, and infants and children with bile-stained vomit should be investigated in hospital.

### GASTRO-OESOPHAGEAL REFLUX DISEASE (GORD)

Reflux of gastric contents is a physiologic occurrence that takes place more often during infancy and decreases with advancing age. The vast majority of infants with gastro-oesophageal reflux (GOR) who are symptomatic of vomiting during the first year of life resolve their overt symptoms between the ages of 12 months and 18 months. Because most infants with symptoms of GOR are thriving and healthy, they require no diagnostic or therapeutic measures other than a careful history and physical examination, with appropriate

reassurance to the parents if they are worried. An increase in the frequency and a decrease in the volume of feeds may reduce symptoms. Also a feed thickener or prethickened formula feed can be used. If necessary, a suitable alginate-containing preparation can be used instead of thickened feeds. However, infants and older children who have significant neurological deficits or psychomotor retardation often have significant GOR and may suffer from serious sequelae secondary to GOR. Oesophageal inflammation (oesophagitis), ulceration or stricture formation may develop in early childhood; GORD may also be associated with chronic respiratory disorders including asthma. Abnormal posturing with the tilting of the head to one side and bizarre contortions of the trunk has been noted in some children with GOR. These symptoms are often referred to as Sandifer syndrome.

The barium swallow is a sensitive way of detecting reflux but has a very low specificity rate because many infants who have little or no clinical symptoms of GOR experience reflux of some barium into their oesophagus. However, a 24-hour pH probe study can give fairly reproducible information on the amount of reflux that is occurring in an infant. Now pH monitor can be done on children as outpatients with the ambulatory device being read by an automatic system at a later date.

Older children with significant GORD should be advised about changing their lifestyle such as weight reduction (if overweight) and avoidance of alcohol and smoking. Also an alginate-containing antacid can be used to relieve symptoms. Children who do not respond to these measures may need histamine H<sub>2</sub>-receptor antagonist to relieve symptoms of GORD, promote mucosal healing and allow reduction in antacid consumption. A proton pump inhibitor can be used for the treatment of moderate, non-erosive oesophagitis that is unresponsive to an H<sub>2</sub>-receptor antagonist. Endoscopically confirmed erosive, ulcerative or stricturing disease in children is usually treated with a proton pump inhibitor and maintained at the minimum effective dose. Furthermore, evidence for the long-term efficacy of motility stimulants such as domperidone or erythromycin in the management of GOR in children is unconvincing.

#### Key Learning Point

- Parents of neonates and infants should be reassured that most symptoms of uncomplicated GOR resolve without treatment.

## GASTROINTESTINAL HAEMORRHAGE

The paediatrician who is confronted with a child with gastrointestinal (GI) haemorrhage faces one of the most difficult diagnostic and management problems in clinical

practice of paediatrics. In spite of the availability of sophisticated diagnostic tools, many paediatric patients with GI haemorrhage remain undiagnosed. However, differentiating upper GI from lower GI bleeding will guide the sequence of diagnostic tests.

Haematemesis is obviously a marker of upper GI haemorrhage and melaena a marker of lower GI bleeding. The term melaena signifies the passage of dark stools stained with blood pigments or with altered blood. It is vital that only after exclusion of upper GI bleeding one should consider a colonic lesion in the case of melaena. On the other hand, the passage of bloody stools (not dark or maroon) points to a colonic source of blood. Small intestinal bleeding may manifest as either melaena or fresh blood. The causes of GI haemorrhage are shown in Table 7.1.

### Diagnosis

A history of haematemesis is suggestive of an upper GI bleeding lesion. Therefore upper GI endoscopy should be carried out and it may lead to the diagnosis. Massive lower GI bleeding in children is uncommon. The presence of leukocytes in the stool suggests an infectious or inflammatory diagnosis. Thus a stool specimen should be sent for culture and identification of parasites. After anal inspection (digital rectal examination), a flexible sigmoidoscopy is indicated. If this is negative, a colonoscopy should be done to visualise the entire colon and the terminal ileum. If melaena (dark stool) is the presenting feature and upper GI endoscopy is negative, colonoscopy should be the next step. However, if

**Table 7.1:** Causes of gastrointestinal bleeding in children

- Haemorrhagic disease of the newborn
- Swallowed maternal blood (neonate)
- Infectious diarrhoea
- Oesophageal varices
- Mallory-Weiss tear
- Gastric and duodenal ulcers
- Meckel's diverticulum
- Intussusception
- Duplication cysts
- Ulcerative colitis
- Crohn disease
- Non-steroidal anti-inflammatory drugs (NSAIDs)
- Vascular malformations
- Anal fissure
- Haemorrhoids
- Henoch-Schönlein purpura
- "Unexplained"

the diagnosis remains unclear, a Meckel's scan may suggest a bleeding site.

### Treatment

Treatment of a massive GI haemorrhage is aimed at resuscitating the patient, localising the site of bleeding, and deciding on a treatment plan to stop the haemorrhage. Treatment for mild bleeding depends on the lesions found.

## OE SOPHAGEAL VARICES

Bleeding from oesophageal varices (Fig. 7.1) may be sudden and profuse and cause exsanguination of the patient. Rapid and adequate transfusion is necessary. Emergency endoscopy should be undertaken in an attempt to establish this diagnosis and injection of varices with sclerosant agents may be commenced. If this is impossible, then control of the bleeding may be achieved by giving intravenous infusions of vasopressin or somatostatin. Tamponading of the oesophageal and gastric varices may be possible with the Sengstaken tube. Someone experienced in proper positioning of the balloons should do insertion of this tube, and it should be done under imaging control. The oesophageal balloon is blown up to a pressure of 40 mmHg. This pressure will have to be released intermittently to prevent pressure necrosis. This measure should only be undertaken in an attempt to resuscitate the patient prior to more definitive treatment, which may include surgical transection of the oesophagus or hemitranssection of the stomach (Tanner's operation). Emergency portocaval or splenorenal shunting is rarely necessary in children. Most patients with portal hypertension and variceal bleeding can



**Fig. 7.1:** Barium swallow demonstrating oesophageal and gastric varices

be managed by repeated injections of sclerosants into the varices, thus allowing collaterals to develop and improve the drainage from the portal venous system.

## PEPTIC ULCER

Although rare in infancy and childhood, gastric and duodenal ulcers may occur. Secondary ulcers (Curling's ulcers) associated with severe infections or extensive burns have become rare.

### Clinical Features

Some of the vague abdominal pains, which are so common in childhood, may be due to undiagnosed peptic ulcer. Indeed, many of these patients may have paid several visits to the hospital and seen several consultants, and eventually referred to the psychiatric department before an underlying peptic ulcer may be diagnosed. While the disease may run a silent course in infancy, in the older child, the clinical picture is similar to that in adult life. There is epigastric pain or discomfort relieved by eating; pain at night is common. Vomiting an hour or two after food may follow pylorospasm or actual scarring of the pylorus. There may be evidence of malnutrition. The disease may present with recurrent or severe haemorrhage or with perforation into the peritoneal cavity, which is very rare. Endoscopy is usually diagnostic although barium meal is less invasive and if indicated may not always reveal a peptic ulcer. During endoscopy, biopsies of the pyloric antrum and the duodenal mucosa are examined to establish the presence of *Helicobacter pylori*. The typical appearance of nodular gastritis is highly suggestive of *H. pylori* infection, especially in the paediatric population. The urea breath test is the most reliable of the non-invasive tests for *H. pylori* infection. If *H. pylori* are present, then the association between them and peptic ulceration is quite high and treatment should be given. Eradication of *H. pylori* infection reduces the recurrence of primary duodenal ulcers in children.

Treatment to eradicate *H. pylori* infection in children consists of: one-week triple therapy regimen that comprises omeprazole, amoxicillin and either clarithromycin or metronidazole. There is normally no need to continue antisecretory treatment (with a proton pump inhibitor or H<sub>2</sub>-receptor antagonist) unless the ulcer is complicated by haemorrhage or perforation. Resistance to clarithromycin or to metronidazole is much more common than to amoxicillin and can develop during treatment. A regimen containing amoxicillin and clarithromycin is, therefore, recommended for initial therapy and one containing amoxicillin and metronidazole for eradication failure. Lansoprazole may be considered if omeprazole is unsuitable. Treatment failure usually indicates antibacterial resistance or poor compliance.

Two-weeks triple therapy regimens offer the possibility of higher eradication rates compared to one-week regimens, but adverse effects are common and poor compliance is likely to offset any possible gain.

#### Key Learning Points

- ⇒ Long-term healing of gastric and duodenal ulcers can be achieved rapidly by eradicating *H. pylori*.
- ⇒ Antacids have been used for many years in the treatment of ulcer disease in infants and children. H<sub>2</sub>-receptor antagonists have made substantial impact on the clinical practice of treating peptic ulcer disease.

## BLOOD PER RECTUM

Passage of blood from the rectum is common in paediatric practice. The diagnosis may be straightforward and the cause obvious, but in many the cause of bleeding is never found even after a full investigation. Serious underlying causes have to be excluded as outlined in Table 7.1.

Most children seen in the outpatient department with rectal bleeding, pass only small quantities of blood after defaecation. Anal fissure is the most common cause, but it may be due to rectal prolapse and proctitis. Acute anal fissure is the most common cause of rectal bleeding. There is usually a history of constipation and generally pain on defaecation. The bleeding is usually small in amount, bright red, streaked on the outside of the stool and occurs during or just after defaecation. The fissure is usually in the midline posteriorly. Perianal redness and shallow fissures may be the first sign of a granulomatous proctitis sometimes associated with Crohn disease. Most fissures are easily seen and digital rectal examination without anaesthesia, which may be very painful, is unnecessary and should be avoided. The management of anal fissures includes stool softening and the short-term use of a topical preparation containing a local anaesthetic. Children with chronic anal fissures should be referred to a hospital specialist for assessment and treatment with a topical nitrate, or for surgery.

Moderate or extensive bleeding is infrequent, but the common lesions are rectal polyps, enteritis or enterocolitis, intussusception, Meckel's diverticulum, volvulus, duplication of the alimentary tract, haemangiomas in the bowel, systemic haemorrhagic disease and in the neonate, necrotising enterocolitis (NEC) and haemorrhagic disease of the newborn.

Digital rectal examination, proctoscopy, sigmoidoscopy, colonoscopy and barium enema may show up the lesion which can then be treated appropriately. A Technetium scan may be necessary to demonstrate a Meckel's diverticulum

or a duplication of the bowel but a negative scan does not exclude either, as it is dependent on the presence of ectopic gastric mucosa.

#### Key Learning Point

- ⇒ Acute anal fissure is the most common cause of rectal bleeding.

## RECTAL PROLAPSE

Rectal prolapse may be partial when the mucous membrane only is prolapsed or complete when there is protrusion of the entire rectal wall (Fig. 7.2). The 1–3 years age group is the usual age. Mucosal prolapse is more common and occurs in children with chronic constipation and is usually initiated by prolonged straining. Prolapse is sometimes the presenting sign of cystic fibrosis. Complete prolapse occurs in debilitated or malnourished children. It is also seen in children with paralysed pelvic floor muscles as in myelomeningocele.

Parents usually notice the red mucosa coming out of the anus after defaecation. The prolapse has usually reduced before the doctor sees the patient. On rectal examination the anal sphincter is found to be very lax and redundant folds of rectal mucosa often follow the withdrawn finger. The child presenting for the first time with a rectal prolapse should have a sweat test performed to exclude cystic fibrosis.

To the parent, a prolapse may be a terrifying event and it is important that the anxious parents are reassured. The prolapse may be reduced by simple pressure or by elevating the foot of the cot, or raising the buttocks on a pillow. Reversion to nappies instead of squatting on the pot should be advised for 3 months from the last prolapse but reassurance that this will not



Fig. 7.2: Rectal prolapse in a child subsequently confirmed as having cystic fibrosis



interfere with long-term defaecation control is necessary. For persistent or frequently recurring prolapse the buttocks may be strapped together and the child given a laxative. In most instances, once the stool is softened, the prolapse becomes less of a problem and rectal prolapse in children is usually a self-curing condition. Only very rarely is it necessary to treat this surgically with injection of phenol in olive oil into the submucosa of the rectum or by a perianal stitch.

#### Key Learning Point

➔ A child presenting for the first time with a rectal prolapse should have a sweat test to exclude cystic fibrosis.

## INTESTINAL POLYPS

A solitary rectal polyp is a common cause of bleeding from the rectum. This low polyp is easily felt on digital rectal examination. The polyp is a granulomatous hamartoma of the mucous membrane, which becomes pedunculated and may protrude at the anus like rectal mucosa prolapse. Polyps high in the rectum and lower colon require sigmoidoscopy under general anaesthesia and may be removed by snaring. Occasionally, juvenile polyps are multiple and may be demonstrated by double contrast studies. True familial polyposis is very rare under the age of 12 years, but the rectum and colon can be carpeted with polyps, which histologically are papillomas or adenomas of the adult type. This disease is usually carried as a Mendelian dominant and cancer of the colon develops in young adult life. Peutz-Jeghers syndrome is a familial condition in which polyps of the small intestine are accompanied by brown pigmentation of the lips and buccal mucosa. Symptoms and signs include repeated episodes of abdominal pain due to transient intussusceptions, blood loss from the intestinal tract and anaemia.

## INFANTILE COLIC

Infantile colic is defined as excessive crying in an otherwise healthy infant. The crying usually starts in the first few weeks of life and ends by 4–5 months. The cause is unclear. It may represent part of the normal pattern of infantile crying. Other possible explanations are painful intestinal contractions, lactose intolerance, gas or parental misinterpretation of normal crying. Infantile colic improves with time.

## RECURRENT ABDOMINAL PAIN IN CHILDREN

Recurring and unexplained abdominal pain often presents a difficult problem to the family doctor and to both the paediatric physician and surgeon. Most of these patients do not have underlying disease; however, they often require evaluation and treatment to allay fears and improve their quality of life. The pain may amount to little more than discomfort.

It may be accompanied by nausea and vomiting. Physical examination should be complete and not only directed towards the abdomen. It is unusual to find any definite signs on abdominal examination and it may be difficult to assess the severity of the pain. Questions, which should be asked, of the pain are:

1. What is the duration of each attack?
2. Is the child ever sent home from school due to the pain?
3. Does it interfere with games or does it become worse when there are household chores to be done or errands collected?
4. Does the pain ever wake up the child from sleep?

Constipation should always be eliminated in these cases and the presence of dysuria, increased frequency of micturition, pyuria or haematuria call for urological investigation. Plain X-rays of abdomen may be useful to reveal a faecalith in an appendix, calcification in mesenteric glands, or calculus formation in the renal tract. Barium meal or barium enema examination may reveal such lesions such as polyps, peptic ulceration or malrotation, which can be a cause of chronic abdominal pain. In the female, recurrent abdominal pain may precede by many months the onset of the first menstrual period (menarche). When organic disease has been reasonably excluded, the proportion of patients who are found to be suffering from emotional disorders is related to the degree of skill and experience in the diagnosis. The term abdominal migraine covers a group of patients who suffer from recurrent attacks of acute, midline abdominal pain, vomiting and headache, photophobia during episodes, family history of migraine with intervening symptom-free intervals lasting weeks to months.

Management of the child with recurrent abdominal pain after treatable causes have been excluded is by reassurance to the patient and parents that there is no serious underlying disease and that symptomatic treatment until the child outgrows the problem is indicated.

## APPENDICITIS

Acute appendicitis is the most common lesion requiring intra-abdominal surgery in childhood. The disease runs a more rapid course in children and the criteria for establishing a diagnosis and for treatment are different. Under the age of four, the diagnosis is difficult and in 90% the infection has spread transmurally to the peritoneal cavity or the appendix has ruptured.

### Pathology

There is marked variation in the anatomy of the appendix. The appendix is attached to the posterior medial quadrant of the caecum. In childhood, the appendix lies in a retrocaecal position in 70% of patients. Obstructive appendicitis is

common in childhood, the obstruction being caused by a kink, a faecalith or the scar of a previous attack of inflammation. When inflammation occurs, there is an accumulation of purulent exudate within the lumen and a closed loop obstruction is established. Blood supply to the organ is diminished by distension or by thrombosis of the vessels and gangrene occurs early in children. Fluid is poured into the peritoneal cavity as a result of irritation, and within a few hours this fluid is invaded by bacteria from the perforated appendix or from organisms translocating the inflamed but still intact appendix. Peritoneal infection may remain localised by adhesions between loops of intestine, caecal wall and parietal peritoneum. There is danger in administering a purgative in these children because it increases intestinal and appendicular peristalsis and perforation and dissemination of infection are more likely to occur.

Appendicitis may present as:

- Uncomplicated acute appendicitis
- Appendicitis with local peritonitis
- An appendix abscess or diffuse peritonitis.

The onset of symptoms is vague and initially may be of a general nature. Only a third of younger patients are seen in hospital within 24 hours of onset of abdominal symptoms, and the appendix has ruptured in a high percentage of these young patients before admission. The diagnosis is made late in many cases. One reason for delay in diagnosis is failure to suspect appendicitis in a child less than 4 years of age and the other is the poor localisation of pain by the younger child. Although often not severe, the pain appears to come intermittently and irritability, vomiting and diarrhoea may result in the mistaken diagnosis of gastroenteritis. Psoas spasm from irritation of the muscle by the inflamed appendix may cause flexion of the hip resulting in a limp, thus distracting attention from the abdomen and directing it to the hip joint. Vomiting occurs in most patients. The child is usually pyrexial, but the temperature is only moderately elevated to between 37°C and 38.5°C. Temperatures higher than this usually suggest upper respiratory tract infections or occasionally diffuse peritonitis from appendicitis. A history of constipation is uncommon and in many patients there is a history of diarrhoea.

The clinical features in the older child are similar to those in the adult. Abdominal pain is usually followed by nausea and vomiting. The pain begins centrally and later shifts to the right iliac fossa. If the appendix is retrocaecal, abdominal pain and tenderness may be slight. If the child has a pelvic appendix then tenderness may again be slight or absent, or elicited only on rectal examination. Anorexia is a common accompanying sign.

### Clinical Examination

The child with acute appendicitis is usually anorexic, listless and does not wish to be disturbed. There is often a characteristic fetid odour from the tongue, which is furred.



**Fig. 7.3:** X-ray of abdomen showing faecalith, scoliosis with psoas spasm, dilated loops of bowel with fluid level and loss of fat line cell

The child is usually irritable, crying and uncooperative. Low-grade pyrexia is usual but the temperature seldom exceeds 38.5°C. Inspection alone may be very informative while attempting to gain the child's confidence. The most important physical sign on abdominal examination is the area of maximum tenderness located in the right iliac fossa and the presence of rebound tenderness. If this is not defined, then a gentle digital rectal examination should be made and tenderness may be elicited or a mass felt in the pelvis in patients with a pelvic appendix.

Urine should be checked for presence of bacteria or white cells and also to exclude glycosuria or significant proteinuria. Leucocytosis is usually present in children with acute appendicitis but a normal white cell count does not exclude the diagnosis. The child with diffuse peritonitis may have a low white cell count. Plain X-ray of the abdomen often gives useful signs of acute appendicitis (Fig. 7.3).

The sensitivity and specificity of ultrasound examination for appendicitis can be quite variable. The examination must be the part of the whole clinical picture in deciding upon operative intervention. Also a negative ultrasound examination does not exclude appendicitis. Use of CT scan of abdomen in the evaluation of difficult cases of abdominal pain has been reported. The CT findings suggestive of appendicitis include appendiceal wall thickening, presence of inflammatory changes in the periappendiceal fat or the presence of an abscess.

### Differential Diagnosis

Differential diagnosis includes numerous other disorders the commonest of which is upper respiratory tract infection.

Presence of a common cold, sinusitis, acute tonsillitis, pharyngitis may all be associated with acute non-specific mesenteric lymphadenitis. This is the most common condition to be differentiated from acute appendicitis. The presence of enlarged glands elsewhere in the body accompanied with an upper respiratory tract infection may suggest this condition. Fever may be absent but temperature can be very high. The presence of abdominal tenderness is not as acute as that in appendicitis. It is usually more generalised and not localised to the right iliac fossa and there is no rebound tenderness. The presence of a cough increased respiratory rate and runny nose may suggest a respiratory infection. Examination of the chest is mandatory to pick up any signs of consolidation as right lower lobe pneumonia may result in referred pain occurring in the right lower quadrant of the abdomen. Constipation can cause abdominal pain, nausea and vomiting, with tenderness over the distended caecum. It can be easily mistaken for acute appendicitis. Faecal masses may be felt per abdomen or on digital rectal examination. Usually following a suppository, satisfactory evacuation of the colon and rectum will bring rapid relief in patients whose symptoms are caused by constipation.

Urinary tract infection can usually be differentiated by a higher temperature, pus cells in the urine, and tenderness over one or other kidney in the renal angle.

Abdominal trauma, accidental or non-accidental may cause injury to the abdominal viscera. A plain X-ray of the abdomen and a serum amylase should be done to exclude the presence of traumatic or idiopathic pancreatitis and a pneumoperitoneum.

In gastroenteritis and dysentery, there may be severe cramping and abdominal pain. The pain and tenderness may be more marked over the distended caecum. Other members of the family may have similar symptoms or diarrhoea. Rectal examination can help differentiate between a pelvic appendicitis and appendicitis with pelvic peritonitis from gastroenteritis.

Infective hepatitis may occur in epidemic form, but in an isolated case may simulate appendicitis. The temperature is usually elevated and the child complains of a headache with nausea, vomiting, abdominal pain and tenderness. On examination, the liver is enlarged and tender. The child may or may not be jaundiced depending on whether he is seen in the prodromal phase of the disease. Examination of the urine usually reveals the presence of bile salts, but urobilinogen may be present.

Intestinal obstruction may be due to incarceration of a hernia, secondary to anomalies, e.g. a volvulus around a vitellointestinal remnant, or adhesions following previous abdominal operations. Vomiting, abdominal colic, abdominal distension and constipation are the usual signs. After a thorough clinical examination, plain X-ray of the abdomen

in the erect and supine positions should be carried out to differentiate intestinal obstruction from appendicitis.

Primary peritonitis is an uncommon diagnosis and almost always affects the female. There is a diffuse infection of the visceral and parietal peritoneum usually due to a pneumococcus. With the peritonitis there is exudation of fluid to the peritoneal cavity. Mesenteric lymph nodes are swollen. Diffuse abdominal pain, vomiting, dehydration and a high fever are the main features and diarrhoea may be present initially, but is usually followed by constipation. Rectal examination usually is suggestive of a pelvic appendicitis as there is diffuse tenderness and heat present. The white blood cell count is usually grossly elevated from 20,000 to 50,000 per cu mm. The diagnosis is usually made at laparotomy when peritonitis is found but the appendix is normal.

Severe abdominal pain and vomiting may occur during passage of a renal calculus. Hydronephrosis due to blockage of the pelviureteric junction by stricture, stone or aberrant vessel may present with abdominal pain and nausea. The pain and tenderness are maximal in the flank. Red or white blood cells may be found in the urine.

Haemolytic uraemic syndrome may present with acute abdominal pain and may be confused with acute appendicitis. The presence of fragmented red blood cells on a blood film and also the presence of oliguria are suggestive of this disease.

Crohn disease is an uncommon diagnosis in childhood but the incidence is increasing in Western countries. It can present with all the symptoms of acute appendicitis and at operation the terminal ileum is found to be acutely inflamed and thickened. A biopsy reveals the diagnosis and barium meal and follow-through very often indicates the presence of other areas of the affected gut.

In torsion of the right cord or testis, confusion with acute appendicitis may occur whereas this is less likely with torsion of the left testis. Routine examination should always include the inguinal regions and the scrotum.

Inflammation of Meckel's diverticulum and intussusception in older children may simulate acute appendicitis. Other medical conditions, which should be considered, are those of diabetes mellitus, cyclical vomiting and Addison's disease. The onset of menstruation may simulate appendicitis and many girls have recurring attacks of lower abdominal pain, sometimes for a year before menstruation actually begins. Pain associated with torsion of an ovary or an ovarian cyst may also present with signs similar to those of acute appendicitis.

It is not uncommon for children to harbour threadworms (pinworms) without noticeable symptoms. Many symptoms and signs have been ascribed to the presence of threadworms including weight loss, poor appetite, nausea, vomiting and chronic abdominal pain.

Carcinoid tumour in the appendix is rare in childhood, but the tumour may obstruct the lumen of the appendix and lead to obstructive appendicitis. It is far more common to find this as an incidental finding on histopathology of the removed appendix. When it is present in the tip of the appendix, no further follow-up is necessary in these cases. In older children, if a carcinoid exists in the caecal region there is a chance of invasive disease with subsequent evidence of the carcinoid syndrome. Treatment should include a right hemicolectomy and careful follow-up with MIBG scan and measurement of 5-HIAA.

## Treatment

The treatment of the child with acute appendicitis is early operation. In the toxic child with peritonitis, time may be profitably spent in combating toxæmia and dehydration. It is important to resuscitate the patient and start intravenous antibiotics before surgery is undertaken. In such cases, metronidazole, ceftazidime and cefotaxime should be given intravenously. The institution of intravenous antibiotics given as three doses pre, per and postoperatively with peritoneal lavage in children with peritonitis has considerably reduced the incidence of postoperative complications. In children, early appendectomy is indicated in the child with appendix abscess. This hastens the recovery period and allows much earlier discharge from hospital.

The best access to the appendix with the minimal disturbance of the peritoneal cavity is through a gridiron or lance incision and appendectomy is performed. There is an increasing trend to perform appendectomy by minimal invasive surgical techniques rather than “open” operation.

Postoperative complication such as wound infection is the most common complication following appendicitis. Since the introduction of metronidazole and cefotaxime given routinely to patients who have appendectomy, the incidence of wound infection has dropped significantly. Evidence of infection may be obvious within a day or two of the operation or may be delayed for several weeks. There is a rise in temperature, local tenderness of the wound, and redness and swelling. Pus may be released by inserting sinus forceps into the edge of the wound to allow it to be discharged.

Localised intraperitoneal abscesses may form after the subsidence of a diffuse peritonitis particularly in the pelvis. Fever may fail to resolve and there is usually lower abdominal pain, tenderness and even diarrhoea with increased frequency of micturition. There may also be abdominal distension due to an associated ileus affecting the terminal ileum. On digital rectal examination, a tender swelling is felt anteriorly. Many pelvic collections resolve on intravenous antibiotics, and very occasionally pus may be evacuated spontaneously through the rectum. Alternatively, drainage through the original incision

under a general anaesthetic and insertion of a Penrose drain to maintain a route to the surface will help clear the pelvic collection. There is no evidence to substantiate the claim that pelvic peritonitis in the young female may lead to sterility in adult life. Subphrenic collections have become extremely rare in children even in those who have had diffuse peritonitis.

Early postoperative intestinal obstruction is usually due to impaired motility of matted loops of ileum lying in pus in the pelvis. Treatment is by antibiotics, intravenous fluids and continuous nasogastric suction. With this conservative management resolution is usual and very few require surgical intervention. If there is volvulus or a closed loop situation then earlier surgical intervention is mandatory in order to relieve the distension and prevent devascularisation of part of the bowel.

Respiratory complications are seldom severe. Mild atelectasis is not uncommon and infection of a collapsed area should be prevented with help from physiotherapists and breathing exercises. Faecal fistula is rare and may be due to necrosis of part of the caecal wall. The fistula usually closes spontaneously with conservative treatment. Rarely a faecalith may have escaped from the necrotic appendix at the original operation and lie in the peritoneal cavity. This causes persistence of a fistula until the faecalith is removed.

## FOREIGN BODIES

Children frequently place objects in their mouth and occasionally accidentally swallow them. Most pass down the alimentary tract and out of the anus in 24–48 hours, but occasionally the coin, pin or toy may stick in the oesophagus. This causes discomfort and inability to swallow freely. The offending foreign body may be removed by passing a catheter beyond the foreign body, inflating a balloon on the distal end of the catheter, prior to withdrawing the catheter and the object proximal to it. If this fails, removal under direct vision through an endoscope under anaesthesia is the preferred method.

Most foreign bodies, which reach the stomach ultimately, pass spontaneously. Two exceptions to the “wait and see” approach are the hairball and batteries. The formation of a hairball (trichobezoar) may be followed by poor health and vague abdominal pain as the gastric lumen becomes partially occluded by a dense mass. The history of hair eating (trichotillomania) is rarely given spontaneously by the child or the parents. A mass may be palpated in the epigastrium. Diagnosis is confirmed by endoscopy or X-ray after a barium swallow. The hairball may be passed spontaneously but gastrostomy may be required. Children swallow small alkaline batteries and the gastric juice may interact with them and if left may cause severe ulceration. These should not be allowed to remain in the stomach for more than 48 hours and may be

removed endoscopically or by gastrotomy under anaesthesia. All other swallowed foreign bodies pass uneventfully through the GI tract once they have reached the stomach.

#### Key Learning Point

- ➔ Ingested foreign bodies: "Wait and See"  
Most ingested foreign bodies, which reach the stomach ultimately, pass uneventfully through the GI tract.

## NECROTISING ENTEROCOLITIS

Necrotising enterocolitis is a severe disease of the GI tract. Prematurity or low birth weight is the most commonly associated factor and occurs in 90% of babies with this disease. Term infants are affected to a lesser extent and constitute about 10% of the affected group. Hypovolaemia and hypoxia result in damage within the mucosa cells initiating the NEC. It is often multifactorial in origin, resulting in loss of integrity of the gut mucosal barrier with passage of bacteria into the wall of the bowel.

Prematurity, respiratory distress syndrome (RDS), congenital cardiac malformations, umbilical vessel catheterisation, exchange transfusions, hypoglycaemia, polycythaemia, postoperative stress and hyperosmolar feeds have all been implicated in the aetiology. Bacterial infection has been implicated in NEC and from time to time one sees some confirmation of this due to the clustering of the disease in neonatal units. There are protective antibodies in breast milk, which decreases but does not completely protect babies at risk from NEC.

The incidence of this disease varies from country to country. There is a very low incidence in Japan and a high

incidence in the United States. The severity of the disease is variable from a minor form seen in many cases, which are managed entirely in the neonatal units, to a fulminating type of the disease with perforation, peritonitis and death.

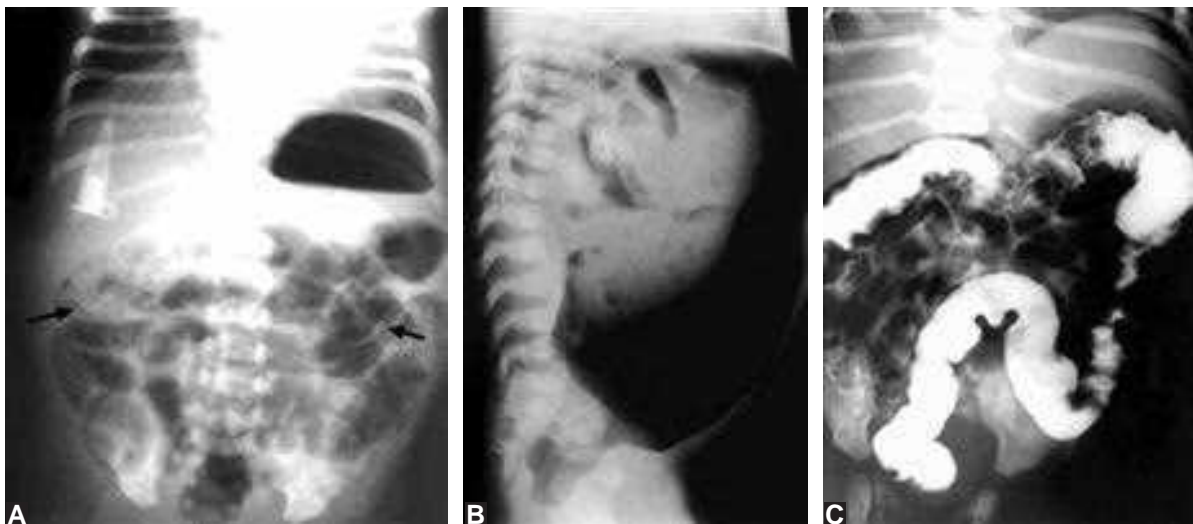
Initially, one sees a preterm infant with signs of sepsis, vomiting of feeds, abdominal distension and frequently the passage of blood or mucus in the stools. Clostridial infections have been associated with some outbreaks of NEC. If the disease continues to progress peritonism develops and this is often appreciated first by nursing staff observing abdominal distension.

Examination of the abdomen may show signs of inflammation, redness, oedema of the abdominal wall with localised or generalised tenderness, and if the baby has a patent processus vaginalis, free fluid or even gas or meconium is occasionally seen in the scrotum. If a perforation has occurred then one loses the area of superficial dullness of the liver on percussion of the abdomen. Palpation may reveal crepitus from the intramural gas, which can be palpated among the coils of distended loops of bowel, and this is an important sign of NEC.

A plain X-ray of abdomen (Figs 7.4A to C) may show pneumatosis intestinalis (gas within the bowel wall) and gas in the portal vein and liver. This sign is often an ominous one with a very high mortality. The extent of the NEC may be localised to an area of the bowel, very often the colon, but in extensive disease the whole of the GI tract may be involved.

The differential diagnosis early in this disease may be difficult and one should consider the following diagnoses:

- Septicaemia from other causes
- Volvulus neonatorum
- Hirschsprung's enteritis
- Infarction of the bowel.



**Figs 7.4A to C:** (A) Abdominal X-ray of premature infant showing pneumatosis (see arrows); (B) The free air in peritoneal cavity indicates perforation; (C) Barium enema showing extensive pneumatosis coli

## Management

Most babies with NEC are managed medically and relatively few require surgical care. Management consists of stopping all oral intake, nasogastric aspiration and instituting intravenous fluids to counteract the hypovolaemia, dehydration and acidosis. Infants with NEC tend to lose a lot of fluid, which is very rich in protein and in electrolytes into the tissues and into the lumen of the bowel. Anaemia, if present, needs to be corrected by blood transfusion, and the fluids, electrolytes and protein replaced. The baby must be maintained normovolaemic with a good peripheral perfusion. On the basis that there is a septic element involved, a broad-spectrum antibiotic is given. Following stabilisation of circulation and ventilation when indicated, total parenteral nutrition is commenced. When the physical signs have reverted to normal, the oral intake is started and gradually built up over several days until full feeds are again established.

## Surgical Management

If there is a persistent acidosis, which often indicates progressive disease or a perforation of the bowel, then surgical intervention is very often necessary. Perforation is detected by seeing free gas in the peritoneal cavity in an erect or lateral abdominal X-ray. In very low birth weight (under 500 g) infants percutaneous drainage has been used in preference to laparotomy. This is performed by means of applying a local anaesthetic to the right lower quadrant of the abdomen, and then a 10–12 French gauge catheter is inserted into the abdominal cavity to drain air, meconium and faecal material which has leaked from perforated bowel.

## TODDLER'S DIARRHOEA

Toddler's diarrhoea is the commonest cause of chronic diarrhoea without failure to thrive in childhood, but its pathogenesis remains unclear. Stool in children with toddler's diarrhoea classically contains undigested food materials due to rapid transit and often is referred to as "peas and carrots" stool.

Diagnosis is based on the history and the clinical criteria: age of onset between 6 months and 36 months, diarrhoea during waking hours and no failure to thrive. Treatment usually is not necessary. Dietary adjustments with elimination of fruit juices and other drinks with high osmotic load may be helpful.

## INFECTIOUS DIARRHOEA IN CHILDHOOD

This has been discussed later in this chapter.

## FERMENTATIVE DIARRHOEA (DISACCHARIDE INTOLERANCE)

In the healthy child, the disaccharide sucrose is split into the monosaccharides, glucose and fructose by small intestinal sucrase-isomaltase enzyme and the disaccharide lactose into the monosaccharides glucose and galactose by the enzyme lactase. Failure of any of these enzyme systems will result of an excess of disaccharide in the intestine where bacteria will ferment the sugars to produce acid and an increased osmotic bowel content. This results in fermentative diarrhoea with the passage of highly acid watery stools. Symptoms are relieved when the offending disaccharide is removed from the diet. Lactase deficiency inherited as an autosomal recessive disorder causes persistent diarrhoea from birth because both human and cows' milk contains lactose. When there is a delay in the onset of symptoms this suggests a sucrase-isomaltase deficiency, as sucrose and starch are not usually added to the diet in the first week after birth. In addition to the autosomal recessive inheritance of the deficiency, there can be transient disaccharide intolerance acquired secondarily to gastroenteritis or other intestinal mucosal insult. Investigations, which help to confirm disaccharide intolerance, include the pH of the fresh stool less than 5.5 and the presence of reducing sugars revealed by the Clinitest and by the identification of faecal sugars on thin-layer chromatography. Removal of all disaccharide from the diet and replacement with monosaccharide will result in a resolution of the diarrhoea. Reintroduction of the disaccharide will result in the return of the diarrhoea and there will be a failure of the normal increase in blood glucose of at least 2.8 mmol/L (50 mg per 100 ml) expected in the normal subject. Rarely a monosaccharide malabsorption syndrome (glucose-galactose malabsorption) can occur. Jejunal biopsy will allow direct measurement of enzyme activity in the jejunal mucosa. The diarrhoea in infants with the hereditary forms of the disorder can be abolished by total exclusion from the diet of the offending carbohydrate.

## Systemic Illness

In addition to the acute diarrhoea caused by food poisoning from food toxins or bacterial toxins, viral, bacterial and protozoal bowel infections there are a number of systemic illnesses, which are complicated by acute diarrhoea and vomiting. Septicaemia, meningitis, pneumonia and infectious hepatitis may be accompanied by diarrhoea and vomiting. Abdominal distension with bloody diarrhoea may suggest an acute surgical condition or the haemolytic uraemic syndrome. Hospital admission is indicated if significant dehydration (more than 5%) is present, when there is doubt about the diagnosis, when hypernatraemia is suspected, when an

underlying medical condition such as adrenogenital syndrome or chronic renal insufficiency is present or when outpatient management has failed or is thought to be inappropriate due to adverse social or other circumstances.

## PARASITIC INTESTINAL INFECTION

It is estimated that between 800 million and 1,000 million people in the world are suffering from at least one type of worm infection. The most important intestinal worms are nematodes and cestodes.

## NEMATODES

These are round, elongated, non-segmented worms with differentiation of the sexes.

### Roundworm (*Ascaris Lumbricoides*)

#### Mode of Infection

Infection arises from swallowing ova from soil contaminated with human excreta. The ova are not embryonated when passed in the faeces but they become infective in soil or water. When swallowed by man the hatched larvae penetrate the intestinal wall and pass via the liver and lungs to the trachea, oesophagus, stomach and intestine where they grow into mature worms (Fig. 7.5).

#### Clinical Effects

A few roundworms in a well-fed patient usually produce no ill effects and are not noticed until a worm is either vomited

or passed in the stool. Typical clinical features include: a protuberant abdomen, intermittent intestinal colic, digestive disturbance, general debility, loss of appetite and insomnia. In heavy infections, worms may migrate into and block the bile duct producing jaundice while similar blocking of the appendix can cause appendicitis. In very heavy infections, intestinal obstruction can occur from a tangled ball of roundworms. The presence and extent of roundworm infection is readily detected by microscopical examination of the stools for ova.

Piperazine citrate in a single oral dose of 75 mg/kg to a maximum single dose of 5 g will clear roundworm from 75% of patients. Two doses on successive days give a marginally higher cure rate. Piperazine citrate has minimum adverse effects—very occasionally unsteadiness and vertigo. Mebendazole is active against threadworm, whipworm and as well as roundworm infections and can be safely recommended for children over the age of 2 years. A dose of 100 mg twice daily for 3 days is effective. Mebendazole is generally considered to be the drug of choice. Levamisole is an alternative when mebendazole cannot be used.

### Hookworms (*Ankylostoma Duodenale* and *Necator Americanus*)

There are two types of hookworms: (1) *Ankylostoma duodenale* being most commonly found in Egypt, Africa, India and Queensland, and also in the Southern USA and (2) *Necator americanus*, which is found in the Americas, the Philippines and India. These two species differ in small anatomical details but their life cycles are identical (Fig. 7.6). The male and

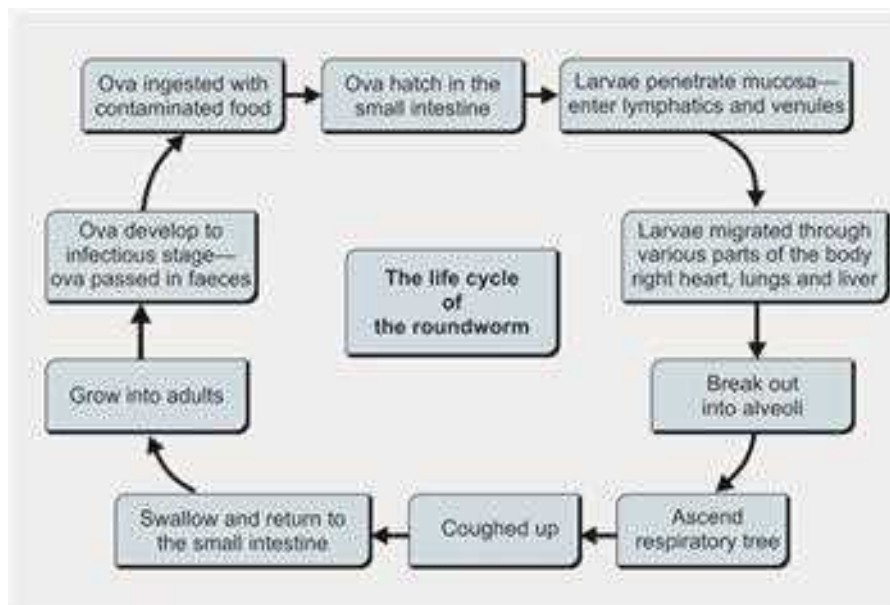


Fig. 7.5: The life cycle of the roundworm

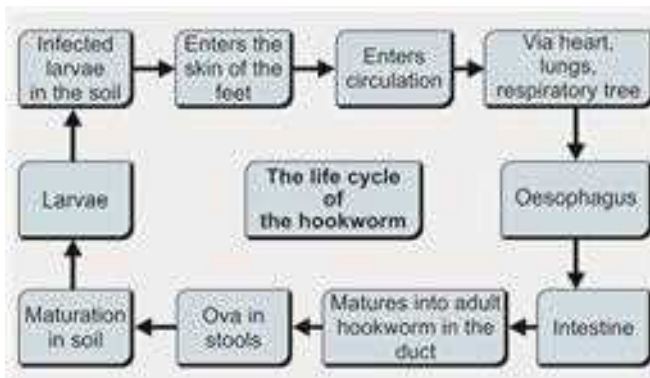


Fig. 7.6: The life cycle of the hookworm

female worms live chiefly in the jejunum. The worm attaches itself to the intestinal mucosa by its teeth and sucks blood. The ova, passed in the faeces, hatch out in water or damp soil and larvae penetrate the skin of the buttocks or feet. They reach the heart and lungs by the lymph vessels and bloodstream, penetrate into the bronchi, are coughed up into the trachea and then pass down the oesophagus to mature in the small intestine.

#### Clinical Effects

The main clinical picture of disease is caused by prolonged loss of blood. Therefore the clinical manifestations of infection depend on the number of worms present and the nutritional state of the patient. A few hookworms in a fairly well-fed person produce no disease as the small blood loss is constantly being replaced. In children whose diet is inadequate and the worm load heavy, severe anaemia may stunt growth, retard mental development and in very severe cases, result in death through heart failure. Infection is diagnosed by microscopical examination of the stools for eggs, the number of which indicates the severity of infection (72,000 ova/g = significant infection).

#### Treatment

Children with severe anaemia and malnutrition should have blood transfusion and nutritional support before definitive worm therapy is started. Mebendazole has a useful broad-spectrum activity and is effective against hookworms; the usual dose for children over one year of age is 100 mg twice daily for 3 days. Albendazole given as a single dose of 400 mg in children over 2 years is an alternative. Levamisole is also effective.

### Strongyloidiasis (*Strongyloides Stercoralis*)

These worms are fairly widespread in warmer climates and may be found concurrently with hookworm infection.

Incidence is often highest in children and the usual mode of infection is penetration of the skin by infective larvae present in the soil. Migration through the lungs also occurs and can produce respiratory signs and there may be abdominal distension, bloody diarrhoea and anaemia. Creeping eruptions, particularly around the buttocks, can develop as a result of the reinfection. Diagnosis is made by identification of larvae in the faeces.

Ivermectin given to children over the age of 5 years in a dose of 200 µg/kg daily for 2 days may be the most effective drug for chronic *Strongyloides* infection. Albendazole is an alternative with fewer side-effects; it is given to children over 2 years of age in a dose of 400 mg once or twice daily for 3 days, repeated after 3 weeks if necessary.

### Threadworm (*Enterobius Vermicularis*, Oxyuriasis, Pinworm or Seatworm)

The male worm is about 3 mm in length and the female, which looks like a small piece of thread, is about 10 mm. The female lives in the colon. Eggs are deposited on the perianal skin by the female contaminating the fingers of the child who may then reinfect himself. The ova after ingestion hatch in the small intestine. The male worm also fertilises the female in the small intestine, after which the male dies while the female migrates to the caecum. It is common for this infestation to affect all members of a family because the ova can be found on many household objects. The initial infection may also be acquired from contaminated water or uncooked foodstuffs (Fig. 7.7).

Clinical features of enterobiasis are mainly perianal, perineal and vulval pruritus, which can interfere with sleep. Scratching leads to secondarily infected dermatitis and to reinfection through contaminated fingers. Heavy infestations could be associated with episodes of severe abdominal

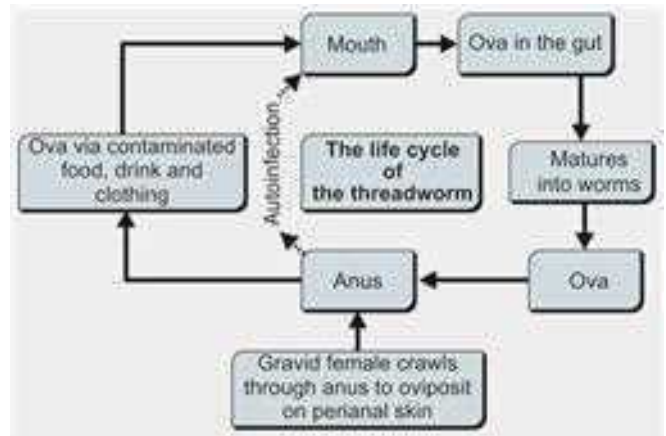


Fig. 7.7: The life cycle of the threadworm



pain. The association of appendicitis with threadworms is exceptionally rare. Diagnosis is made by direct examination of the worms or ova trapped by “sellotape” applied sticky side to the anal skin early in the morning and then stuck on to a glass slide.

Mebendazole is the drug of choice for treating threadworm infection in children over 6 months. It is given as a single dose as reinfection is very common, a second dose may be given after 2 weeks. Piperazine is also effective. Measures to break the cycle of reinfection should be taken and these include scrupulous personal hygiene, boiling all infected linen and the wearing of occlusive clothing to prevent scratching. Treatment should also be given to other members of the family and it should be reinstated when symptoms recur and eggs are again found in the perineal area.

### Larva Migrans

#### Cutaneous Variety (Creeping Eruption)

Cutaneous larva migrans is caused by the infective larvae of various dog and cat hookworms. These larvae can penetrate the human skin and finding themselves in an unsuitable habitat wander around in the epidermis for several weeks. Their progress is marked by a characteristic itching and a serpiginous urticarial track. The infection is more common in children than in adults and is occasionally seen in people recently returned from tropical countries.

Treatment by freezing the advancing end of the track with dry ice or liquid nitrogen is no longer recommended. Applications of topical 15% thiabendazole powder in water soluble base with or without diethylcarbamazine 5 mg/kg per day for 7 days will eliminate the larvae. Multiple infections respond to ivermectin, albendazole or thiabendazole by mouth.

#### Visceral Variety

This is caused by various species of the nematode *Toxocara*, usually *Toxocara canis* the common roundworm of the dog. The larvae may penetrate the intestinal wall but are unable to migrate to the lungs of their unnatural host and pass through or become encysted in liver, lungs, kidneys, heart, muscle, brain or eye, causing an intense local tissue reaction. The child may fail to thrive, develop anaemia and become pyrexial with a cough, wheeze and hepatosplenomegaly. There is usually a marked eosinophilia and there can be CNS involvement. In addition to this generalised form of the disorder, there may in the older child (7–9 years old), isolated loss of sight in one eye associated with ocular toxocariasis. The diagnosis can only be established with certainty from a tissue biopsy; generally taken from the liver and the *Toxocara* ELISA test is a useful screen.

Recently thiabendazole 50 mg/kg body weight for 3–5 days has been shown to kill encysted larvae and is especially useful for early ocular lesions. Normally the visceral variety is self-limiting and requires no treatment. Regular and routine deworming of puppies and pregnant bitches with mebendazole, prevention of face licking by dogs and the need to wash hands carefully after handling pets are preventative health measures. Multiple infections respond to ivermectin, albendazole or thiabendazole by mouth.

## CESTODES

Cestodes (tapeworms) of importance to humans are *Taenia saginata* (beef tapeworm), *T. solium* (pork tapeworm), *Hymenolepis* species (dwarf tapeworm), and *T. echinococcus* (hydatid cyst).

The ingestion of raw or inadequately cooked beef or pork can result in human infection. Man is the definitive host for both the beef (*T. saginata*) and pork (*T. solium*) tapeworms. Although the infections may be asymptomatic, epigastric discomfort, increased appetite, dizziness and loss of weight sometimes occur. These features may be more marked in children and debilitated persons. Diagnosis is based on the passage of gravid segments through the anus. The differentiation can be made by a microscopical study of the number of lateral branches in the gravid uterus of each segment, the uterus of *T. solium* having about 10 branches and that of *T. saginata* about 20.

With *T. solium* infection a major danger is the ingestion of eggs from an infected person (heteroinfection) or self-ingestion of eggs (autoinfection). This can give rise to cysticercosis where cysticerci develop almost anywhere including brain, skin, muscle and eye.

### *Taenia Echinococcus* (Hydatid Cyst)

The definitive host of *T. echinococcus* is the dog, wolf, fox or jackal. Man and sheep may become the intermediate host by swallowing the ova from the dog and this is especially likely in sheep-rearing countries. The adult worm in the dog is very small (0.5 cm) but the ingested ovum when swallowed by man liberates a 6-hooked oncosphere into the small intestine. This penetrates to the tissues, usually the liver but sometimes lung, bones, kidneys or brain to form a hydatid cyst. This has a 3-layered wall—an outer layer of host fibrous tissue, a laminated middle layer and an inner germinal layer that produces many daughter and granddaughter cysts.

#### Clinical Effects

These are largely due to local pressure effects. The liver may be greatly enlarged and there may be a palpable rounded swelling over which the classical “hydatid thrill”

can be elicited. Ultrasound and CT scanning can reveal the cystic nature of the lesions. Eosinophilia may be marked. The diagnosis may be confirmed by complement fixation, haemagglutination or latex-slide agglutination tests but the hydatid ELISA test and improved immunoelectrophoresis tests are likely to prove more specific.

### Treatment

The only measure is surgical incision. The cyst must never be tapped as a leakage of hydatid fluid into the tissues can cause shock or death. The outlook is grave if suppuration occurs within the cyst. Spontaneous recovery can occur if the cyst dies, inspissates and calcifies. Medical treatment for this most important tapeworm infecting man is generally unsatisfactory but albendazole is used in conjunction with surgery to reduce the risk of recurrence or as primary treatment in inoperable cases. Albendazole is given to children over 2 years of age in a dose of 7.5 mg/kg (maximum 400 mg) twice daily for 28 days followed by 14-day break and then repeated for up to 2–3 cycles. Careful monitoring of liver function is particularly important during drug treatment.

### Hymenolepis (Dwarf Tapeworm)

Mild infestations due to *Hymenolepis* (dwarf tapeworm) cause no symptoms, but heavy infestations can sometimes cause diarrhoea, irritability and fits. Diagnosis is made by finding the typical ova in the faeces.

### Treatment

Niclosamide is the most widely used drug for tapeworm infections and side effects are limited to occasional GI upset, light-headedness and pruritus. It is not effective against larval forms. A laxative may be given 2 hours after the dose; an antiemetic may be given before treatment.

Praziquantel is as effective as niclosamide and is given to children over 4 years of age as a single dose of 10–20 mg/kg after a light breakfast (or as a single dose of 25 mg/kg for *Hymenolepis nana*).

## INFLAMMATORY BOWEL DISEASE

The term inflammatory bowel disease (IBD) includes two clinical conditions in children, ulcerative colitis and Crohn disease (Table 7.2). On the whole the prognosis of chronic IBD in childhood is good.

### Ulcerative Colitis

#### Aetiology

The aetiology is unknown. It is fortunately rare in children. Over the past decade, it would appear that there has been

**Table 7.2:** Clinical features of ulcerative colitis and Crohn disease

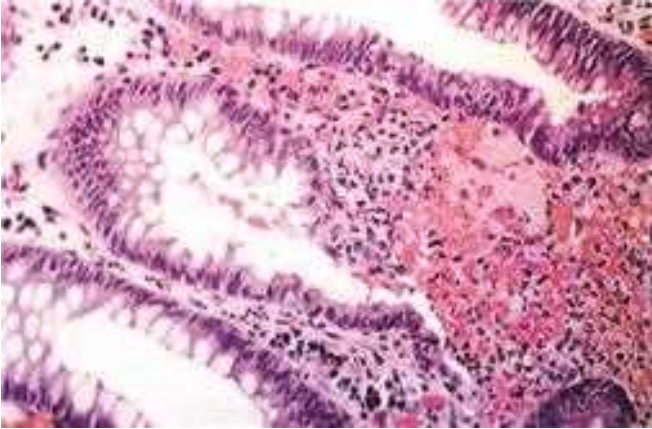
Clinical features	Ulcerative colitis	Crohn disease
Location	Rectum and colon (variable)	Ileum and right colon
Diarrhoea	Severe	Moderate
Mucus blood	Frequent	Infrequent
Rectal involvement	Always	Infrequent
Fistula in ano	Absent	Infrequent
Perirectal abscess	Absent	Infrequent
Abdominal wall fistula	Absent	Infrequent
Toxic megacolon	Infrequent	Absent
Arthritis	Rare	Common
Eye pathology	Rare	Iridocyclitis, granuloma
Proctoscopic appearance	Diffuse, ulceration	Cobblestone
Small bowel involvement	Absent	Frequent
Microscopic appearance	Mucosal ulceration	Transmural granulomas

little change in the incidence of ulcerative colitis but Crohn disease has increased. The reason for the change is not clear.

Severe behavioural problems in some of the affected children and their families have sometimes led physicians to regard the disease as a psychosomatic disorder, but the evidence in support of this hypothesis is extremely slender. Food allergy has been suspected, but only a small group of patients respond to withdrawal of milk. Boys and girls are equally affected. The mean age of onset is about 10 years. There is no clear-cut inheritance pattern but ulcerative colitis is more common in first-degree relatives than in the general population.

#### Pathology

The mucous membrane of part or all of the colon and sometimes of the terminal ileum becomes hyperaemic, oedematous and ulcerated. The lesion is continuous rather than patchy and usually involves only the mucosal and submucosal layers. The earliest lesion in many cases is a crypt abscess (Fig. 7.8). Granuloma formation is rare. In some cases, oedema may give rise to pseudopolypoid nodules. Ulceration may extend through the muscularis and perforation of the colon can occur. Usually perforation is preceded by toxic megacolon with dilatation of an ulcerated segment of the large bowel. Carcinoma is a common late complication. Hepatic complications such as sclerosing cholangitis and chronic active hepatitis can occur with ulcerative colitis in childhood.



**Fig. 7.8:** Ulcerative colitis. Rectal biopsy with crypt abscess formation (obj x 25)



**Fig. 7.9:** Barium enema showing loss of normal haustrations (lead-pipe appearance in the colon) in ulcerative colitis

### Clinical Features

The onset is sudden with diarrhoea and the frequent passage of small stools containing blood and mucus. This tends to be most severe during the early morning but may also be nocturnal. There may be abdominal pain, anorexia, weight loss or poor weight gain. Tenesmus is common.

Hypochromic anaemia due to chronic blood loss is almost invariably present. Hypoproteinaemic oedema may develop. Associated extraintestinal manifestations of the disease are more common in children than in adults. They may include erythema nodosum, aphthous stomatitis, conjunctivitis, iridocyclitis, haemolytic anaemia, arthralgia or arthritis, pyoderma gangrenosum and finger-clubbing.

After exclusion of infective causes of bloody diarrhoea the diagnosis should be confirmed by rectosigmoidoscopy, mucosal biopsy and barium enema. The last shows loss of normal haustrations in the colon and the so-called “lead-pipe” appearance (Fig. 7.9). Colonoscopy may allow the examination of the whole colonic mucosa and thus the extent of the disease. Radiologically differentiation of Crohn disease from ulcerative colitis can be made on the basis that Crohn disease can affect any part of the GI tract and is patchy in distribution, whereas ulcerative colitis is a continuous lesion affecting only the rectum, colon and occasionally the terminal ileum (backwash ileitis). It is worth remembering that early in the course of disease no X-ray abnormality may be found.

Ulcerative colitis frequently runs an acute course in the child. The cumulative risk of carcinoma of the colon is 20% per decade after the first decade of the illness. Dysplastic changes in the colonic epithelium are considered to be premalignant.

### Crohn Disease

#### Aetiology

This disorder like ulcerative colitis is not common in children and it is of unknown cause.

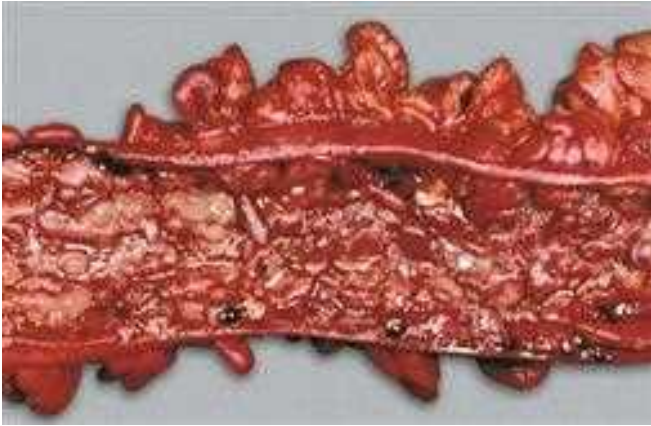
#### Pathology

Crohn disease may affect any part of the GI tract but most commonly the terminal ileum and proximal colon. Although any part of the GI tract from mouth to anus may be affected. The lesions are basically chronic granulomatous and inflammatory with a tendency towards remissions and relapses. The histological changes are transmural, i.e. affecting all layers of the bowel wall with oedema and ulceration of the mucosa, fissures, submucosal fibrosis and many inflammatory foci of mononuclear and giant cells (Figs 7.10 and 7.11). Perforation, haemorrhage and fistula formation are uncommon complications in childhood.

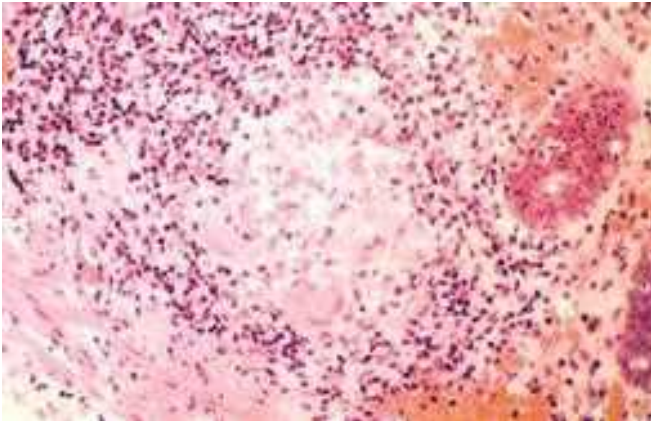
#### Clinical Features

In Crohn disease the diarrhoea is much less severe than in ulcerative colitis; it is often intermittent and there may be little or no obvious blood or mucus in the stools. Crohn disease presents with less specific signs and symptoms than ulcerative colitis hence the delay in diagnosis often found in Crohn disease.

General manifestations commonly include anaemia, loss of weight, growth failure, pubertal delay, erythematous



**Fig. 7.10:** Crohn disease. Open loop of ileum showing typical cobblestone appearance of the mucosa



**Fig. 7.11:** Crohn disease showing a diagnostic granuloma in the lamina propria of a colonic biopsy with a central collection of epithelioid and multinucleate cells surrounded by a cuff of lymphocytes and plasma cells (obj x 25)

rashes and a low-grade fever. Other associated features are: erythema nodosum, pyoderma, iridocyclitis, arthralgia or arthritis, spondylitis, finger-clubbing, anal skin tags, fissures and fistulae. Quite frequently the disease presents with oral ulceration and this may progress to extensive involvement of the buccal mucosa, which becomes oedematous and granulomatous sometimes years before there is evidence of intestinal involvement. There is no single gold standard for the diagnosis of Crohn disease. The diagnosis is made by clinical evaluation and a combination of endoscopic, histological, radiological and biochemical investigations. Sigmoidoscopy is only helpful when the left side of the colon is involved. A barium meal or enema typically shows segmental involvement of the small bowel and/or colon, sometimes with intervening areas of normal bowel (Fig. 7.12). Crohn disease shows a segmental lesion while ulcerative colitis is diffuse. The appearances vary from a “cobblestone appearance” due to



**Fig. 7.12:** Barium meal and follow-through illustrating segmental involvement of the same bowel (Crohn disease)

thickened oedematous mucosa to narrowing of the lumen with the so-called “string sign”. There may be fistulous tracts to adjacent loops of bowel. Biopsy of a perirectal lesion or even of the involved buccal mucosa may reveal diagnostic granulomatous changes. Colonoscopy and biopsy may provide an immediate diagnosis.

### *Prognosis*

Crohn disease is a lifelong condition, with periods of active disease alternating with periods of remission.

### *Treatment of Ulcerative Colitis and Crohn Disease*

To date, the standard therapies for Crohn disease and ulcerative colitis have been similar and in general can be classified as anti-inflammatory, or immunosuppressive therapy. 5-Aminosalicylic acid compounds, antibiotics, and nutritional therapy usually are considered as anti-inflammatory, whereas 6-mercaptopurine, azathioprine, cyclosporin A, and methotrexate have immunosuppressive properties. Some therapies, such as corticosteroids have both.

The general principle of IBD (irritable bowel disease) treatment mainly depends on the disease severity and it aims with the treatment that has the best possible chance of obtaining clinical remission with the fewest side effects. However, depending on the child’s therapeutic responses or lack thereof, additional medications are added to the therapeutic regimen. Some of the differences in therapy between Crohn and ulcerative colitis include surgical intervention,

antibiotics, and nutritional therapy. The surgical intervention is used in both ulcerative colitis and Crohn disease but is only curative in ulcerative colitis and is reserved exclusively for localised Crohn disease such as strictures and fistulas. The antibiotic therapy is beneficial in Crohn disease, whereas it has been used rarely in ulcerative colitis. The nutritional therapy is vital from the growth perspective in both diseases but is shown to be effective in the control of Crohn disease symptoms only. So due attention should be paid to diet; high fibre or low residue diet should be used as appropriate.

Recently advances in immunology have led to discovery of several new immunotherapies referred to as biologics. Together with infliximab, which has been approved for the treatment of Crohn disease, other biologic therapies may be available in the near future. However, infliximab is recommended for the treatment of severe active Crohn disease (with or without fistulae) when treatment with immunomodulating drugs and corticosteroids has failed or is not tolerated and when surgery is inappropriate. Infliximab is not recommended for the treatment of sub-acute manifestations of moderate to severe active ulcerative colitis that would normally be managed in an outpatient setting.

## COELIAC DISEASE (GLUTEN-SENSITIVE ENTEROPATHY)

### Aetiology

Coeliac disease (CD) is now regarded as an autoimmune type of chronic inflammatory condition and may have its onset at all ages. It is apparent that the harmful substance is in the gliadin fraction of gluten in wheat, barley and rye flour. The immune-mediated enteropathy is triggered by the ingestion of gluten in genetically susceptible individuals. Gluten is a mixture of structurally similar proteins contained in the

cereals, wheat, rye and barley. CD is associated strongly with HLA class II antigens DQ2 and DQ8 located on chromosome 6p21. CD is frequent in developed world and increasingly found in some areas of the developing world, e.g. North Africa and India.

### Pathology

Histological features have been defined mainly from study of jejunal biopsy specimens. The most characteristic appearance is called total villous atrophy in which the mucosa is flat and devoid of normal villi but the underlying glandular layer is thickened and shows marked plasma-cell infiltration (Figs 7.13A and B). Absence of villi has been confirmed by electron microscopy. In other cases, however, there is subtotal villous atrophy in which short, broad and thickened villi are seen. Children with dermatitis herpetiformis also have an intestinal lesion similar to that of CD.

### Clinical Features

These do not develop until gluten-containing foods are introduced into the infant's diet. In many cases the first signs are noted in the last 3 months of the first year of life, but the child may not be brought to the doctor until the second year. Delayed introduction of wheat containing cereals into the diet of infants in recent years has resulted in the later onset of CD.

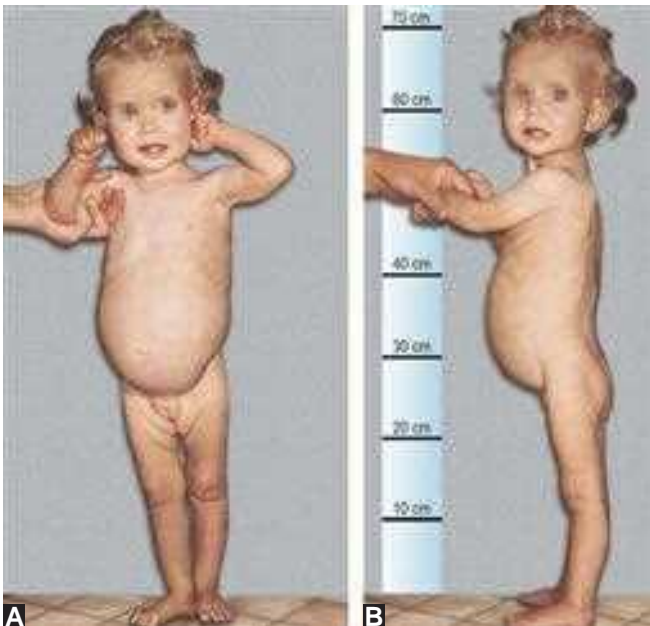
Affected children become fractious and miserable with anorexia and failure to gain weight. Stools are characteristically of porridge consistency, pale, bulky and foul smelling, but in some children this feature is not very marked. In others, however, the illness may start with vomiting and watery diarrhoea. The abdomen becomes distended as a result of poor musculature, altered peristaltic activity and the accumulation of intestinal secretions and gas.



**Fig. 7.13A:** Normal jejunal biopsy: long finger-shaped villi, short crypts, scattered chorionic inflammatory cells in the lamina propria and occasional lymphocytes in intraepithelial spaces (obj x 10)



**Fig. 7.13B:** Total villous atrophy with loss of villi, elongated hyperplastic crypts, dense plasmacytic infiltrate in the lamina propria and increased number of surface intra-epithelial lymphocytes (obj x 10)



**Figs 7.14A and B:** (A) A 14-month-old girl with untreated coeliac disease. Note abdominal distension and gross tissue wasting; (B) Lateral view of the same patient

This contrasts with the child's wasted buttocks and thighs and produces the so-called coeliac profile (Figs 7.14A and B). A small number of children may be desperately ill with profuse diarrhoea leading to dehydration, acidosis and shock (coeliac crisis). In the worst cases malabsorption of protein can lead to hypoproteinaemic oedema. Some children may present with prolonged fatigue ('tired all the time'), recurrent abdominal pain, cramping or distension.

Various other defects in absorption may become clinically manifest. Iron deficiency anaemia is common. There is usually diminished absorption of folic acid as revealed by a reduced red cell folate concentration. If there is ileal involvement, serum B12 may be decreased. Although deficiency of vitamins A and D is probably always present, rickets is quite rare (due to lack of growth) and xerophthalmia is almost unknown. However, rickets may develop after starting treatment with a gluten free diet if supplements of vitamin D are omitted while active growth continues. Hypoproteinaemia is often present.

There has been a change in the clinical presentation of the disease since a large fraction of affected patients mainly adults remain undiagnosed due to atypical or vague symptoms, or even the absence of symptoms. We should be especially aware of the disease in certain risk groups, i.e. first-degree relatives of patients with diagnosed disease, patients with autoimmune diseases such as type 1 insulin dependent diabetes, autoimmune thyroid disease, dermatitis herpetiformis and child with Down syndrome.

## Diagnostic Tests

While the definitive diagnosis of CD must rest upon jejunal biopsy, the procedure is unpleasant and requires admission to hospital. A variety of screening tests have been developed. The use of serological markers, i.e. serum antigliadin (AGA), antiendomysial (IgAEMA) and antitissue transglutaminase (IgAtTGA) antibodies of IgA isotype for case finding and epidemiological studies is mandatory. However, IgA deficiency must be excluded. Patients with IgA deficiency will have a false negative result if IgA based serological tests are used. However, IgGtTGA and/or IgGEMA serological tests should be carried out in patients with confirmed IgA deficiency. The testing for CD is accurate only if the child continues to follow a gluten-containing diet during the diagnostic process (serological tests, jejunal biopsy).

A barium meal and follow-through examination will reveal an abnormal coarsening of the mucosal pattern of the small bowel, jejunal dilatation and possibly delay in the passage of barium to the colon. The bones may become osteoporotic and ossification delayed.

No investigation apart from small intestinal biopsy is 100% diagnostic of children who have CD.

### Key Learning Point

#### Diagnosis of coeliac disease

- ➔ The only diagnostic test for CD at present is small intestinal biopsy while the child is on a gluten-containing diet "The Gold Standard for Diagnosis". Serological tests do not diagnose CD, but indicate whether further testing is needed.

## Treatment

Coeliac disease is a gluten-sensitive enteropathy and the results of treatment with a gluten free diet are impressive. This is first apparent as a striking improvement in personality soon to be followed by rapid growth, while the stools more slowly return to normal. Strict supervision is essential and the child's height and weight should be recorded at regular intervals. A delayed diagnosis of CD or undiagnosed CD can result in growth failure, delayed puberty and dental problems.

The parents should be supplied with a comprehensive list of the many foodstuffs which contain gluten and are, therefore, forbidden; also a list of the gluten free foods which are freely permitted. Bread and biscuits made from gluten free wheat starch are commercially available. It is also possible to home bake gluten-free bread, biscuits and cakes with recipes supplied by dietitians.

An adequate intake of vitamins and especially of Vitamin D is important. Iron deficiency anaemia may be corrected with oral preparations of iron supplements. When the red

cell or whole blood folate value is low, folic acid should be prescribed in a dose of 5 mg daily.

### Key Learning Point

#### Treatment of coeliac disease

- Effective treatment for CD is available through lifelong adherence to a strict gluten-free diet, i.e. exclusion of all foods containing wheat, rye or barley.

As long as the child remains on a gluten free diet growth and development will be entirely satisfactory, and the mortality rate for CD is nowadays negligible. It is, however, recognised that adults who have been successfully treated for CD in childhood and who have gone back to an ordinary diet, may later relapse. It is therefore desirable to confirm the persistence of true gluten intolerance in these so-called “coeliac children” before recommending a life long gluten free diet. There is, in addition, the risk that the poorly treated adult coeliac may in time develop a lymphoma or GI carcinoma.

The therapeutic trial of a gluten free diet without a prior biopsy is a dangerous practice and should be abandoned.

## CYSTIC FIBROSIS

### Aetiology

Cystic fibrosis (CF) is an autosomal recessive hereditary multi-organ disease caused by mutations in the CF transmembrane conductance regulator gene. The gene, which codes for this protein is located on chromosome 7 and the most common so far described is at the DF 508 locus and accounts for about 74% of cases in Caucasians. Although the incidence varies considerably between ethnic groups and populations, CF seems to be present in every population studied. CF is much less common in native African and native Asian populations.

### Pathology

Although the gene defect is present in all nucleated body cells it is only in those cells where the gene requires to be activated for normal cell function that abnormalities are recognised. It is not surprising that the disease has variable clinical manifestations given the range of gene defects. The pancreas is abnormal in over 90% of the cases. A constant change is fibrosis with atrophy of the exocrine parenchyma. Cystic dilatation of acini and ducts is common but not invariable. Islet tissue, however, is rarely involved until later childhood or adolescence. Mucous glands throughout the body are grossly distended and they secrete abnormal viscid mucus. Stagnation of mucus in the smaller bronchioles usually leads to infection, which in turn stimulates further mucus secretion. The non-resolving neutrophilic inflammatory

response to chronic infection in turn causes progressive and permanent airway damage, such that bronchiectasis and respiratory failure are the common findings in end-stage CF lung disease. The liver shows a focal type of biliary cirrhosis, most marked under the capsule, which may progress to produce portal hypertension.

### Clinical Features

While most CF patients present disease symptoms at birth or in early infancy, some may not be diagnosed until adulthood.

The symptoms tend to occur in a more or less ordered fashion and the diagnosis is not often unduly difficult. In about 10% the illness presents in the neonatal period in the form of meconium ileus in which inspissated meconium causes intestinal obstruction. The most common presentation, however, is in the form of an intractable respiratory infection dating from the early weeks or months of life. Indeed, cystic fibrosis of the pancreas should always be suspected when a respiratory infection in infancy fails to respond promptly to adequate antibiotic therapy. In the early stages of the disease radiographs of the chest may show only increased translucency of the lung fields; later heavy interstitial markings appear; then multiple soft shadows representing small lung abscesses. In other cases there may be lobar consolidation, empyema or pyopneumothorax. In children who survive the early months of life, the respiratory picture may become that of bronchiectasis, increasing emphysema, and clubbing of the fingers. Sputum culture in such cases will most often show the predominant organisms to be *Staphylococcus aureus* and *Pseudomonas aeruginosa* and other gram-negative bacteria (e.g. *Burkholderia cepacia* complex, *Stenotrophomonas maltophilia*, *Achromobacter xylosoxidans*) often dominate the clinical picture. For respiratory manifestations of CF, discussed in Chapter 6 (Respiratory Disorders).

In a minority of cases the respiratory infection is less prominent than the presence of semi-formed, greasy, bulky and excessively foul smelling stools. These features coincide with the introduction of mixed feeding. After the first year of life the history of abnormal and frequent stools occurring in association with abdominal distension and generalised tissue wasting may simulate CD. The differential diagnosis can, however, almost always be made on clinical grounds alone. In cystic fibrosis a careful history will elicit that signs first appeared in the early weeks of life, whereas CD rarely presents before the age of 6 months. The excellent, often voracious appetite in cystic fibrosis contrasts sharply with the unhappy anorexia of the coeliac child. Chronic respiratory infection of some degree, often severe, is an invariable accompaniment of cystic fibrosis but it is not a feature of CD. Furthermore, the diagnosis of cystic fibrosis may be suggested by a history that previous siblings have the disease.

If the affected infant survives the first year, childhood seems often to bring a period of improvement in the chest condition. All too frequently, however, the approach to puberty is associated with cor pulmonale. Less commonly, in about 10% during the second decade, biliary cirrhosis and portal hypertension develop and may lead to massive GI haemorrhage. In recent years as an increasing proportion of sufferers from cystic fibrosis survive insulin dependent diabetes mellitus has been found in some as they approach puberty. A further important manifestation, which seems to present in a majority of male survivors into adulthood is aspermia and sterility. This has been shown to be due to absence of the vas deferens. Women have only slightly reduced fertility associated with abnormal tubal ciliary movement and cervical mucus.

#### Key Learning Point

- The vast majority of men with CF (98%) are infertile due to abnormalities in the development of structure derived from the Wolffian duct.

Some children with cystic fibrosis can develop distal small bowel obstruction. This disorder is due to viscid mucofaeculent material obstructing the bowel causing recurring episodes of abdominal pain, constipation and acute or sub-acute intestinal obstruction. The cardinal sign is a soft, mobile, non-tender mass palpable in the right iliac fossa. Mild cases can be treated by increasing the intake of pancreatic enzyme. If the condition is not improved oral N-acetylcysteine 10 ml four times a day or one or two doses of oral Gastrografin 50–100 ml taken with 200–400 ml of water may relieve the patient discomfort and obstruction. Toddler's with cystic fibrosis may sometimes present with rectal prolapse. Also the incidence of nasal polyps in patients with cystic fibrosis is about 70%.

### Diagnostic Tests

The sweat test is still sufficient to confirm the diagnosis in typical cases but gene screening for known mutations is now becoming routine in many centres. The sweat test can be carried out from the third week of life on, provided the infant weighs more than 3 kg, is normally hydrated and without significant illness. There are various methods of obtaining sweat for analysis but the most accurate and widely used technique is stimulation of local sweating by pilocarpine iontophoresis. One should try to achieve the collection of at least 100 mg of sweat. To minimise diagnostic errors, two reliable sweat tests confirmed in a laboratory used to performing the test should be obtained. Diagnostic levels of sodium and chloride are 60 mmol/kg. In patients with atypical disease manifestations, the sweat test is often

equivocal. Additional diagnostic tests will be necessary to substantiate the diagnosis: CFTR mutation analysis and, at times, CFTR bioassays.

In neonates, there is a reliable method of screening which is based on the serum concentration of immunoreactive trypsin (IRT). Serum IRT levels are abnormally high (> 80 ng/ml) during the first few months of life, although in older children they fall to subnormal values. Prenatal diagnosis by chorionic villus biopsy obtained at 9–12 weeks postconception will allow termination of affected foetuses. As there is still no curative treatment for CF the introduction of screening has to be considered regionally, in close cooperation with CF centres.

#### Key Learning Point

- A sweat chloride concentration of greater than 60 mmol/L confirms the clinically suspected diagnosis of CF.

A majority of patients with cystic fibrosis have pancreatic insufficiency which if inadequately treated could result in fat, vitamin and protein malnutrition. The most important factors in the treatment are control of lung infection and maintenance of adequate nutrition; indeed upon the success of these efforts depend the prognosis. Persistent bacterial infection is a major problem for children with cystic fibrosis; the four bacterial pathogens involved being *S. aureus*, *P. aeruginosa*, *Haemophilus influenzae* and *B. cepacia*.

The intensive long-term antibiotic treatments, developed at many centres, have resulted in problems with resistant strains. Different treatment strategies have been developed, most focusing on preventing colonisation with gram-negatives, mainly *P. aeruginosa*. The strategies contain generalised pulmonary mucus-dissolving agents, physical therapy and antibiotics.

Antibiotic treatment with intravenous antimicrobial drugs at signs of exacerbation of the pulmonary symptoms has been the most widely used treatment modality. In the struggle to keep the infectious load as low as possible more or less continuous inhalation therapy has been more common in recent years. The cost of intravenous therapy can also be kept relatively low by teaching parents and patients to perform home intravenous antibiotic therapy, which also gives the family more freedom and acceptance of treatment.

Patients should be considered for lung transplantation when there lung function is impaired to a FEV1.0 of less than 30% of the predicted values.

All children with cystic fibrosis should receive pertussis, measles, *H. influenzae* and influenza vaccinations.

The services of a surgeon may be required at several stages of the disease, e.g. for meconium ileus in the neonatal period, for distal small bowel obstruction, for lobectomy



in bronchiectasis or for portacaval anastomosis if portal hypertension is severe.

There has been amazing success in the treatment of CF, a condition that was once frequently fatal in the first year of life. Identification of CFTR (CF transmembrane conductance gene) has been a key step in understanding pathophysiology at a molecular level and establishing the degree to which variation in CFTR function influences the outcome of CF.

Supplements of pancreatin are given by mouth to compensate for reduced or absent exocrine secretion in CF. The dose of pancreatin is adjusted according to size, number, and consistency of stools, and the nutritional status of the child. High strength pancreatin preparations have been associated with the development of large bowel strictures in children aged between 2 and 13 years. Therefore the total dose of pancreatic enzyme supplements used in children with CF should not usually exceed 10,000 units of lipase per kg per day. Pancreatin is inactivated by gastric acid juice, therefore pancreatin preparations are best taken with food. In CF children with persistent malabsorption of fat despite optimal use of enzyme replacement, an H<sub>2</sub>-receptor antagonist or a proton pump inhibitor may improve fat digestion and absorption. Pancreatin can irritate the perioral skin, buccal mucosa and excessive doses can cause perianal irritation.

#### Key Learning Point

- Most patients with CF die from end-stage pulmonary disease; therefore, emphasis is on prevention and treatment of pulmonary infections. Most patients would benefit from improved nutrition, including refined pancreatic supplementation therapy and essential fatty acid status.

## IDIOPATHIC CHILDHOOD CONSTIPATION

Terminology is a problem, which causes confusion in communication between doctors and patients. It is important that the doctor be sure of the patient's understanding of the terms used. Constipation may be defined as a difficulty or delay in defaecation that causes distress to the child and the parents. The infrequent passage of stools with no distress does not fall into this category. Encopresis or faecal soiling is the frequent passage of faecal matter at socially unacceptable times. This has been discussed in Chapter 31 (Disorders of Emotion and Behaviour). Psychogenic causes are the most frequent. Faecal continence is the ability to retain faeces until delivery is convenient. Ingestion of fluid or food stimulates the gastrocolic reflex and results in two or three mass colonic propulsive activities per day. This process delivers faecal material to a normally empty rectum. On distension of the rectum, stretch receptors start a rectal contraction and a reflex

inhibition is sent to the anal canal. This is mediated via the myenteric plexus of nerves in the submucosa and the plexus of nerves between the outer longitudinal and inner circular smooth muscle layers. The process produces sensation since the upper part of the anal canal has sensitive sensory receptors as well as stretch receptors. The motor element of the external sphincter and the puborectalis muscle make up the striated sphincter together with the smooth muscle of the internal sphincter. The striated sphincter is able to contract strongly to prevent the passage of a stool at an inconvenient time. This, however, can only function for 30 seconds, i.e. long enough to contain a rectal contraction wave till it passes. The internal sphincter can maintain persistent tonic activity so preventing leakage of stool between periods of rectal activity by maintaining closure of a resting anal canal. Clinical experience suggests that the external sphincters are of much less importance than the puborectalis sling and the internal sphincter. Defaecation occurs by inhibiting the activity of the puborectalis sling and the sphincter mechanism of the anus, thus allowing faeces to pass from the rectum into the anal canal. This is augmented by voluntarily increasing intra-abdominal pressure using the abdominal wall musculature as well as the diaphragm as accessory muscles for defaecation. There are two main clinical states, the acute and the chronic state, which must be differentiated. Some children with physical disabilities, such as cerebral palsy are more prone to idiopathic constipation as a result of impaired mobility. Children with Down syndrome and autism are also more prone to the condition.

#### Key Learning Point

- Hirschsprung's disease, CF, anorectal anomalies and metabolic conditions such as hypothyroidism are rare organic causes of childhood constipation.

### Acute Constipation

Acute constipation usually occurs in a child after a febrile illness with a reduced fluid intake. This situation arises when convalescing after an illness or in the immediate postoperative period. There is a danger that this acute state of constipation may progress to a chronic state if it is not identified early enough. Treatment with a laxative, suppositories or an enema usually corrects the problem initially but the child must be encouraged to return to a good diet and adequate fluid intake.

### Chronic Constipation

Chronic constipation is distressing to the child and the parents. An early diagnosis is essential to prevent a prolonged and persistent problem. In chronic constipation the rectum is overstretched and ballooned. The sensory receptors are

inactive and the bowel is flaccid and unable to contract effectively. A greater amount of water is absorbed from the faecal stream. The stool becomes harder, more solid and more difficult and painful to pass. The faecal mass increases in size and spurious diarrhoea can also occur from stercoral ulceration of the distended rectal mucosa.

History is important as failure to pass meconium within 24 hours of birth in the term infant born normally, makes it likely that there may be some underlying problem. Infants, for whom childbirth has been abnormal, take longer to establish a normal defaecation pattern. The delay in establishing normal stooling may be a sign of other disorders, not only Hirschsprung's disease or anal stenosis, but systemic disorders such as hypothyroidism. Psychogenic causes are the commonest origin of constipation in childhood often due to inappropriate toilet training and this aspect has also been discussed in Chapter 31 (Disorders of Emotion and Behaviour).

In older infants and children the distress caused by constipation may be related to pain. There may be abdominal discomfort, usually a dull ache, which may or may not be related to defaecation. Occasionally the pain may be localised to the right iliac fossa due to a distended caecum filled with stool. The pain may be in the anal region, particularly when an anal fissure has occurred and bleeding may result from the mucosal tear.

There are occasions when there is no complaint of constipation but the parents may notice a distended abdomen, and may even at times feel a mass arising out of the pelvis.

A full dietary history must be obtained. This should include a detailed account of a typical day's breakfast, lunch, supper and any in-between snacks, noting the amount of fluid taken, any dietary fads and the amount of fruit and vegetables and cereals ingested.

An accurate account of drugs given and other remedies tried by the parents before presenting at the clinic is documented.

## Examination

A full examination of the child is important noting the presence of any dysmorphic features, height and weight as well as any signs of failure to thrive. Inspection of the abdomen noting any abdominal distension or the presence of localised swelling. The abdomen is then palpated in routine fashion, feeling for any abdominal mass. A faecal mass can usually be indented through the abdomen, although at times the impacted mass may be so hard as to make it quite impossible to indent, and may mislead one into thinking it is a malignant mass. A loaded, impacted colon with a megarectum can in turn cause retention of urine resulting in a full bladder, which may or may not distress the child if this is a chronic situation.

Digital rectal examination must be carefully explained to the parents and the child before proceeding, explaining the importance of deciding whether constipation is a problem especially in the presence of diarrhoea, which may be spurious in nature. It is helpful to have a nurse in attendance to position the child in the left lateral position with knees bent in the foetal position. It is useful to carry on conversation during this investigation to relax an otherwise tense atmosphere and also explaining to the parent and the child what is being done. While the child is in this position, it is important to examine the spine and the sacrum for any sign of spina bifida occulta. The position of the anus as well as its size should be noted to exclude the possibility of an anterior ectopic anus or an anal stenosis. The skin around the anus should look normal. Erythema may indicate the presence of candida or streptococcal infection or may be due to topical applications by the parents. The presence of puckering of the anus as well as the presence of a skin tag may indicate an underlying anal fissure, which could be the result of the vicious cycle of retention of stool, chronic constipation and painful defaecation. The presence of soiling should be noted and the consistency and volume of stool, if it is hard or soft or liquid in form, as well as whether there is any blood present.

### Key Learning Points

#### May not be idiopathic constipation—diagnostic clues are:

- If constipation has occurred from birth or first 2 weeks of life
- If there is history of failure to pass meconium/delay of greater than 48 hours after birth
- If there is undiagnosed weakness in legs, locomotor delay
- If there is abdominal distension with vomiting
- If lower limb reflexes are abnormal
- If spine, lumbosacral region/gluteal examination shows sacral agenesis, naevi, hairy patch, asymmetry or flattening of gluteal muscles.

## Investigations

A plain abdominal radiograph is only indicated in the ongoing management of intractable idiopathic constipation. A plain X-ray of the abdomen in a child with a distended abdomen and constipation may indicate the degree of constipation and may also detect underlying bony abnormalities such as spina bifida occulta or sacral abnormalities. Barium enema (Fig. 7.15) may be carried out in a few children with chronic constipation where there is a suspicion of Hirschsprung's disease but in most children radiological investigations are not required if an adequate history is taken. These children must not be prepared by bowel washout prior to the barium enema because this will obscure the X-ray appearance.



**Fig. 7.15:** Barium enema of a child demonstrating gross rectal dilatation and obstruction with mass of faeces (“terminal reservoir”)

Transit studies are not required to make a diagnosis of idiopathic constipation. However, consider transit studies and abdominal ultrasound in the ongoing management of intractable idiopathic constipation.

### Management of Acute Constipation

It is important to explain the mechanism of acute constipation to the parents and the child and to emphasise the benign nature of this condition. It is treated by increasing the fluid and fibre content of the diet or, if necessary, a bulk agent to restore the normal pattern of defaecation of the child.

### Management of Chronic Constipation

The management of this condition involves getting the cooperation of the child, the parents, as well as the general practitioner and the nurse. An explanation of the cause of the intractable problem should be given to the parents. Dietary measures with a high fluid intake and an adequate dietary residue should be commenced. Bran should be added to the cereal in the morning. In addition to this it is necessary to dislodge the faecal masses with oral preparations of laxatives. Stool softeners and laxatives are titrated according to the clinical response. A sodium citrate enema or a phosphate enema is sometimes necessary. Although rectal use of laxatives may be effective, this route is frequently distressing for the child and may lead to persistence of withholding. During the period of impaction, soiling is often worse and this has to be explained to the parents so that they are not disheartened. The period of regulation of bowel habits to food and fluid

intake may take several months to achieve. Occasionally manual evacuation under general anaesthesia is necessary to dislodge firm impacted faecal masses; before continuing with prolonged dietary and medicinal management.

Long-term regular use of laxatives is essential to maintain well-formed stools and prevent recurrence in children with chronic constipation or a history of faecal impaction; intermittent use may provoke relapses. The laxatives have been divided into five main groups: (1) bulk-forming laxatives, (2) stimulant laxatives, (3) faecal softeners, (4) osmotic laxatives and (5) bowel cleansing preparations. Bulk-forming laxatives are of value if the diet is deficient in fibre. They relieve constipation by increasing faecal mass which stimulates peristalsis. Stimulant laxatives increase intestinal motility and often cause abdominal cramp; therefore, they should be avoided in intestinal obstruction. Stools should be softened by increasing dietary fibre and liquid or with an osmotic laxative, before giving a stimulant laxative. The faecal softeners such as enemas containing arachis oil lubricate and soften impacted faeces and induce a bowel motion. Osmotic laxatives increase the amount of water in the large bowel, either by drawing fluid from the body into the bowel or by retaining the fluid they were administered with. Bowel cleansing preparations are not treatments for constipation. Laxatives should not be stopped abruptly but the dosage should be reduced gradually over a period of months in response to stool consistency and frequency.

#### Key Learning Point

- ➡ Laxatives should be given at a time that produces an effect that is likely to fit in with the child's toilet routine. Also use dietary modifications, non-punitive behavioural interventions and daily physical activity tailored to the child's age.

Some children require referral for psychological help to treat underlying problems of a psychogenic nature, but this should be only done once other disease processes have been excluded [discussed in chapter 31 (Disorders of Emotion and Behaviour)]. Children with intractable idiopathic chronic constipation who still have unresolved symptoms on optimum management may need referral to a paediatric surgical centre for an antegrade colonic washouts enema (ACE) procedure.

### PROTEIN-LOSING ENTEROPATHY

The intestinal loss of proteins may be greatly increased in many diseases, not only diseases which primarily affect the GI tract but many other more generalised disorders such as cystic fibrosis, CD and Henoch Schonlein purpura.

Little is known about the mechanisms by which the plasma proteins reach the lumen of the gut. In inflammatory and ulcerative conditions local exudation of protein seems the obvious explanation. In other conditions such as lymphangiectasia, retroperitoneal fibrosis and congestive cardiac failure, the loss may be accounted for by disturbance of lymphatic drainage. For the most part the mechanism remains obscure. The classification in Table 7.3 includes those found in children.

Gastrointestinal protein loss is non-selective. Serum proteins are lost 'in bulk' irrespective of molecular size. Although all serum proteins may be reduced the abnormality is most obvious in the reduction in concentration of albumin, IgG, IgA, and IgM. Abnormal intestinal protein loss may occur without any clinical manifestations.

However, at serum levels below 4 g per 100 ml there is an increasing risk of peripheral oedema, which may then become a major or even the presenting complaint.

Protein-losing enteropathy (PLE) may be suspected in any case of unexplained hypoproteinaemia or oedema especially in the presence of GI symptoms. Suspicion is strengthened by the demonstration of particularly low levels of albumin and immunoglobulins. The diagnosis is proved by the use of such tests as the use of <sup>51</sup>Cr-labelled serum proteins. The measurement of faecal  $\alpha_1$  antitrypsin can be used to document protein loss and to potentially localise the site of

**Table 7.3:** Diseases associated with protein-losing enteropathy

- Invasive bacterial infection (e.g. Salmonella, Shigella)
- Crohn disease
- Ulcerative colitis
- Intestinal tuberculosis
- Sarcoidosis
- Intestinal lymphangiectasia
- Retroperitoneal fibrosis
- Neoplasia affecting mesenteric lymphatics
- Thoracic duct obstruction
- Congestive cardiac failure
- Menetrier disease
- Cystic fibrosis
- Milk and Soy-induced enteropathy
- Henoch-Schönlein purpura
- Giardiasis
- Kwashiorkor
- Venous-occlusive disease
- Necrotising enterocolitis
- Tropical sprue
- Graft-versus host disease

loss. Diagnosis is not complete without the demonstration of excess intestinal protein loss. It is necessary to determine the nature of the causative disease. Treatment is the treatment of that disease.

## WILSON'S DISEASE (HEPATOENTERIC DEGENERATION)

Caeruloplasmin is a copper-containing  $\alpha_2$  globulin, which functions as a transport mechanism for copper in the plasma. Deficiency of caeruloplasmin is associated with copper deposition in many tissues resulting in Wilson's disease.

### Clinical Features

Wilson's disease may present any time from early childhood to the fifth decade. In early childhood, hepatosplenomegaly, jaundice and acute hepatitis or nodular cirrhosis of the liver are the most common findings. This disease should always be considered in such cases. A brown or green ring around the corneal limbus—the Kayser-Fleischer ring—is caused by copper deposited in Descemet's membrane. It is only found in this disease. The ring is often not present under the age of seven.

Urine, plasma and tissue concentrations of copper are high and serum caeruloplasmin (or copper oxidase activity) is usually low, although rare families with normal caeruloplasmin levels have been reported. Plasma caeruloplasmin levels are very low in the normal newborn, rising to normal by about 2 years of age.

### Diagnosis

Tissue copper is high but serum copper and caeruloplasmin are low, although rare forms are known in which the caeruloplasmin level may be normal although its functional activity is impaired. In these cases, liver biopsy or radioactive copper uptake may be required to make the diagnosis. Some heterozygotes have reduced caeruloplasmin levels; others can be distinguished by measuring caeruloplasmin uptake of radioactive copper. Slit lamp examination may be needed to see the Kayser-Fleischer (K-F) rings.

#### Key Learning Point

- ➔ The diagnosis of Wilson's disease may be made readily when the classic triad of hepatic disease, neurologic involvement and K-F rings are present.

### Treatment

It is important to diagnose the disease early since treatment can prevent the onset of symptoms, and can result in striking clinical improvement. Oral D-penicillamine is the drug of

choice. Children who are hypersensitive to penicillin may react rarely to penicillamine. The drug should be continued for life. Trientine is used for the treatment of Wilson's disease only, in patients intolerant of D-penicillamine.

Zinc prevents the absorption of copper in Wilson's disease. Symptomatic patients should be treated initially with a chelating agent because zinc has a slow onset of action. When transferring from chelating treatment to zinc maintenance therapy, chelating treatment should be co-administered for 2–3 weeks until zinc produces its maximal effect.

Liver transplantation has also been reported to reverse all the neurologic and biochemical abnormalities.

## JAUNDICE

Jaundice occurs either when there is excess haemolysis increasing the load of bilirubin, when the diseased liver is not able to cope with the normal load or when there is obstruction to excretion of bilirubin. Jaundice can be classified into haemolytic (prehepatic), hepatocellular (hepatic) and obstructive (posthepatic) varieties. In this chapter, the authors have discussed only virus hepatitis, chronic active hepatitis and cirrhosis of the liver. Neonatal jaundice has been discussed in chapter 3 (Neonatal Paediatrics) and obstructive jaundice in chapters 11 (General Paediatric Surgery) and 13 (Paediatric Oncology). Carotenoderma (Carotenaemia) is characterised by yellow skin pigmentation ("carroty") usually as a result of excessive dietary intake of foods rich in  $\beta$ -carotene. The pigmentation is marked on the nasolabial folds, palms and soles. Constitutional symptoms seldom appear in carotenoderma. The sclerae are not icteric and this helps to distinguish carotenoderma from jaundice. Also serum bilirubin is within the normal range but plasma carotene level is raised. Occasionally it is associated with hypothyroidism, diabetes mellitus, or nephrosis.

### Key Learning Point

#### Jaundice versus carotenoderma (carotenaemia)

- ➔ There is no scleral icterus in carotenoderma, and this helps clinically to distinguish it from jaundice.

## VIRAL INFECTIONS OF THE LIVER

### Hepatitis A

Hepatitis A virus (HAV) is present in the blood and stool of a patient for 2–3 weeks before clinical symptoms occur and it persists in stool for up to 2 weeks after disease onset. The primary mode of transmission is faecal-oral route. Common source outbreaks occur with contamination of water or food. In developing countries with inadequate hygiene and poor

sanitation HAV infection is endemic and most children are infected in the first year of life.

### Clinical Features

Hepatitis A virus infection is usually an acute self-limiting illness. The mean incubation period is 30 days. In infants and young children, the infection could be entirely asymptomatic. Jaundice is rare in this age group. In older children, there may be a prodromal period of several days in which fever, headache and malaise predominate, followed by the onset of jaundice, abdominal pain, nausea, vomiting and anorexia. Pruritus may accompany the jaundice.

Clinical examination may reveal a mildly enlarged tender liver and occasionally splenomegaly is noted.

Serum aminotransferase values usually are often 20 to 100 times the upper limit of normal and they decrease rapidly within the first 2–3 weeks.

### Diagnosis

The diagnosis of HAV infection is made by detection of the immunoglobulin M antibody to HAV (IgM and anti-HAV).

### Prevention

Hepatitis A vaccine should be considered for children with chronic liver disease including chronic hepatitis B or chronic hepatitis C; prevention of secondary cases in close contacts of confirmed cases of hepatitis A, within 7 days of onset of disease in the primary case. Protection against hepatitis A is recommended for travellers to high-risk areas. Hepatitis A vaccine is preferred as compared to immunoglobulin and it is likely to be effective even if given shortly before departure. Intramuscular normal immunoglobulin is no longer recommended for routine prophylaxis in travellers but it may be indicated for immunocompromised patients if their antibody response to vaccine is unlikely to be adequate. In unimmunised children, transmission of hepatitis A is reduced by good hygiene.

### Hepatitis B

Hepatitis B virus (HBV) is relatively uncommon in Caucasians but has a high prevalence in Southeast Asia and parts of Africa where highly infective carriage of HBV is common. The incubation period is 90–120 days. Hepatitis B virus is found in high concentration in the blood of infected individuals and in moderate concentrations in semen, vaginal fluid and saliva. Risk factors for acquisition of HBV infection include parenteral exposure to blood or blood products. Risk factors in children include perinatal exposure (vertical) being born to an HbsAg seropositive mother. Horizontal spread is by living in a household with a chronic HBV carrier.

The hepatic injury that occurs with HBV infection is mediated by the host immune response. Most instances of HBV infection are acute and self-limited. In some individuals HBV is not cleared by the host immunologic response, and chronic infection results.

### *Clinical Features*

After an incubation period of 30–180 days, patients with HBV infection may develop a prodrome that consists of malaise, fatigue, nausea, low-grade fever, or even a serum-sickness like illness. Papular acrodermatitis of childhood may be the major or only manifestation of HBV in infants and young children. Patients who manifest these pro-dromal symptoms are already seropositive for HbsAg.

Within a week or two of the prodrome, clinical hepatitis is seen with jaundice, pruritus, nausea and vomiting. Clinical examination reveals mild hepatomegaly and liver tenderness and mild splenomegaly may also be noted. Serum bilirubin and aminotransferase levels decrease over several weeks to normal. However, in those children who will develop fulminant hepatitis, the typical features of coagulopathy and encephalopathy will appear. In patients who develop chronic HBV infection, jaundice clears, but alanine transaminase (ALT) and aspartate transaminase (AST) may or may not return to normal.

Chronic HBV infection is often completely asymptomatic and may not be diagnosed if the patient has not had an acute icteric illness. Chronic hepatitis may manifest as a complication of cirrhosis or portal hypertension. Chronic HBV infection is highly associated with the risk of developing hepatocellular carcinoma.

### *Diagnosis*

The diagnosis of acute HBV infection is made by detection of HbsAg and IgM anti-HBc; although HbeAg confirms active replication, its presence is not essential to confirm the diagnosis. Chronic HBV infection is defined by the presence of HbsAg for more than 6 months; typically it persists for many years. In chronic HBV infection, HbeAg persists, often for many years, indicating ongoing viral infection.

### *Treatment*

Treatment for acute hepatitis B is mainly supportive and most patients recover fully. Chronic HBV infection is a rare indication for liver transplantation in the paediatric age group.

### *Prevention*

Hepatitis B vaccine is used in individuals at high risk of contracting hepatitis B. A combined hepatitis A and hepatitis B vaccine is available. They include:

- Close family contacts of a case or carrier, children travelling to areas of high prevalence
- Babies whose mothers have had hepatitis B during pregnancy or are positive for hepatitis B surface antigen (regardless of e-antigen markers)
- Children with chronic liver disease, chronic renal failure including those on haemodialysis
- Parenteral drug abusers and their household contacts, children with haemophilia, those receiving regular blood transfusions or blood products.

## **Hepatitis C**

Hepatitis C virus (HCV) was discovered in sera from patients with post-transfusion hepatitis, and is now the predominant cause of transfusion associated non-A, non-B hepatitis in the world. However, since the institution of screening donors for antibody to HCV (anti-HCV) and thus eliminating positive blood/blood products, the risk of HCV from transfusion has diminished. On the other hand the proportion of cases associated with intravenous drug abuse has increased. However, exposure to blood products and perinatal exposure have been the most consistent risk factors for HCV acquisition in children. The incubation period for post-transfusion HCV infection ranges from 2–26 weeks.

### *Clinical Features*

Many acute HCV infections are clinically asymptomatic but those who become icteric show a modest rise in aminotransferase levels. Some patients have symptoms of acute hepatitis, such as anorexia, malaise, fatigue and abdominal pain. In most instances, chronic HCV infection is asymptomatic.

### *Treatment*

At present there are no widely accepted recommendations for treatment of acute HCV infection in children. Interferon has been used with some success in chronic hepatitis C infection.

## **Hepatitis D (Delta Hepatitis)**

Delta hepatitis is caused by the hepatitis D virus (HDV). It occurs only in conjunction with hepatitis B infection. In general, HDV infection does not have specific features to distinguish it from ordinary HBV infection. Testing for HDV infection is recommended in any child with chronic HBV and unusually severe liver disease. Several antiviral drugs have been studied in Delta hepatitis, but the only treatment that has had a beneficial effect is 1FN- $\alpha$ . Passive or active immunisation against HDV infection is not available.

## **Hepatitis E**

Hepatitis E virus (HEV) infection is also called enterically transmitted non-A, non-B hepatitis. The symptoms and signs

are similar to those of hepatitis A. At present, the diagnosis depends on the detection of anti-HEV IgM. Prevention is by improving standards of hygiene. No therapy or prophylaxis currently exists.

### Hepatitis G

The clinical significance of hepatitis G virus (HGV) remains uncertain. This virus has not been implicated in acute non-A, non-E hepatitis or fulminant hepatic failure in children.

### Hepatitis Caused by Other Viral Agents

Hepatitis viruses A, B, C, D and E are the agents of most viral hepatitis. Other viruses that can cause hepatitis as part of a generalised illness (CMV, herpes virus, EB virus, human parvovirus B 19, rubella, coxsackie B, and yellow fever hepatitis and dengue haemorrhagic fever) will not be discussed here.

## CIRRHOSIS OF THE LIVER

### Aetiology

Hepatic cirrhosis is uncommon in children in the United Kingdom and the histological differentiation into “portal” and biliary” types tend to be less well defined than in adults. A pathological picture similar to that of Laënnec portal cirrhosis may follow neonatal hepatitis, blood group incompatibility, the de Toni-Fanconi syndrome and it may be the form of presentation of Wilson’s hepatolenticular cirrhosis. Infective hepatitis-B may also lead to hepatic cirrhosis. Other rare causes of cirrhosis of the liver include galactosaemia, Gaucher’s disease, Niemann-Pick disease and xanthomatosis. Pure biliary cirrhosis is seen invariably in congenital biliary atresia and a focal type is very common in cystic fibrosis of the pancreas.

Indian childhood cirrhosis (ICC) is a common and fatal disease, which appears to be restricted to India. There is a positive family history in about 30% of cases. It is not found in Indian expatriates in other parts of the world. It usually presents between the ages of 9 months and 5 years and has characteristic histological features in liver biopsy material. These have been called “micro-micronodular cirrhosis” which includes necrosis and vacuolation of liver cells, aggressive fibrosis both intralobular and perilobular and a variable inflammatory infiltrate. The liver contains an exceedingly high copper content and the hepatocytes contain multiple, coarse, dark brown orcein-staining granules, which represent copper-associated protein. The pathogenic role of chronic ingestion of copper was supported by the finding of a much greater use of copper utensils to heat and store milk by families of affected than unaffected children. Since then, the use of copper pots has reduced, and the disease has largely

disappeared from many parts of India. Recently a copper-binding factor has been identified in ICC, liver cytosol. This factor may play a role in hepatic intracellular copper accumulation. Penicillamine given before the terminal stages has reportedly reduced mortality from 92% to 63%.

In Jamaica a form of cirrhosis called veno-occlusive disease of the liver, in which there is occlusion of the small hepatic veins, is due to the toxic effects of an alkaloid in bush tea compared from plants such as *Senecio* and *Crotalaria*.

### Chronic Active Hepatitis

Chronic active hepatitis is an autoimmune disorder characterised by hepatic necrosis, fibrosis, plasma cell infiltration and disorganisation of the lobular architecture. In the young adult, often female, associated disorders include thyroiditis, fibrosing alveolitis and glomerulonephritis. Some cases are related to chronic virus B hepatitis (positive HBsAg). In chronic active hepatitis smooth muscle antibodies are found in the serum in two-thirds of cases, antinuclear factor in about 50%, and the gamma globulin level is markedly elevated.

### Clinical Features

The child usually presents with abdominal swelling due to enlargement of the liver, which has a firm edge, sometimes smooth, often nodular. Anorexia, lack of energy and slowing of growth are common complaints. Splenomegaly develops if there is portal hypertension. In most cases jaundice makes its appearance sooner rather than later. Spontaneous bleeding is usually due to hypoprothrombinaemia. Orthochromic anaemia is common. When ascites develop the outlook is grave; it is usually associated with hypoproteinaemia and portal hypertension. The latter may result in massive GI haemorrhage. In other cases death occurs from hepatic encephalopathy with flapping tremor, mental confusion, extensor plantar responses and coma. Spider naevi and “liver palms” are uncommon in children, but clubbing of the fingers may develop. Hypersplenism may produce leucopaenia and thrombocytopenia. Various derangements of liver function can be demonstrated biochemically, e.g. raised direct bilirubin levels, hypoalbuminaemia, and raised serum gamma globulin. In hepatic encephalopathy the blood ammonia level is high. Diagnosis should be confirmed by liver biopsy.

### Treatment of Hepatic Disorders

Specific treatment is available only for the few cases due to metabolic errors such as Wilson’s disease or galactosaemia. Life can be prolonged with a high protein diet, plus a liberal intake of the B vitamins and oral vitamin K, 10 mg per day. Ascites should be treated with frusemide and a low-sodium

diet. Hypokalaemia may require supplements of potassium chloride. In resistant cases diuresis may be improved by giving (along with frusemide) an aldosterone antagonist such as spironolactone, 25 mg four times daily. Paracentesis abdominis should be avoided whenever possible. When signs of hepatic failure supervene protein should be completely eliminated from the diet and the therapeutic regimen for this emergency should be started. There is little basis for the use of corticosteroids save in chronic active hepatitis where they do probably slow down the progress of the disease. An alternative but more dangerous therapy is immunosuppression, e.g. with azathioprine. Fortunately, children have a large reserve of hepatic metabolic capacity, therefore modification of the choice and dosage of drugs is usually not required, even in apparently severe liver disease. However, use of hepatotoxic drugs is more likely to cause toxicity in children with liver disease. It would be prudent to avoid such drugs if possible.

### Obstructive Jaundice

Obstructive jaundice has been discussed in details in Chapter 11 (General Paediatric Surgery).

### Cholecystitis

Cholecystitis is uncommon in childhood and rarely presents as an acute emergency. Cholelithiasis is less common in infancy and childhood. It presents with recurrent upper abdominal pain, nausea and vomiting. It is often associated with congenital spherocytosis. The stones are usually bile pigment stones and should be looked for whenever laparotomy is carried out for removal of the spleen in this condition. Most gallstones are clinically silent. Ultrasonography is the most sensitive and specific method to detect gallstones. Cholecystotomy has been preferred to cholecystectomy when the gallbladder is not diseased.

## PANCREAS

Pancreatic disorders are uncommon in childhood except that which is part of the generalised disease of cystic fibrosis. Pancreatitis presents as an acute abdominal emergency but the signs and symptoms are less dramatic than in adults. Single, self-limited attacks, or recurrent attacks of acute pancreatitis are, by far the most frequent feature of this disease in childhood. Chronic pancreatitis is quite rare in children. Based largely upon clinical and epidemiological observations, a broad spectrum of underlying conditions has been associated with acute pancreatitis. According to one series, trauma, structural disease, systemic diseases, drugs and toxins are the major etiological factors. A variety of systemic infectious agents have been implicated in the aetiology of acute pancreatitis. The mumps virus is

an important cause of acute pancreatitis in children. Acute pancreatitis has been reported in association with a variety of connective tissue disorders. Abdominal pain and vomiting are the most consistent signs. Abdominal tenderness is more marked in the upper abdomen. There is a lack of a “gold standard” diagnostic test for acute pancreatitis. However, considerable diagnostic importance has been placed on the total serum levels of amylase or lipase, but the specificity and sensitivity of these tests is unsatisfactory. Ultrasonography is now the most commonly used test in the preliminary evaluation of children with abdominal pain when pancreatitis is suspected. Abdominal CT should be reserved where ultrasound examination is technically unsatisfactory.

### Treatment

It consists of the treatment of pancreatic disease symptoms and complications. Most specific therapeutic interventions are of questionable or unproven benefit.

## JUVENILE TROPICAL PANCREATITIS

The syndrome of chronic pancreatitis with pancreatic calculi and diabetes has been reported from many countries such as Uganda, Nigeria, Sri Lanka, Malaysia, India, and Bangladesh. The exact aetiology has not yet been established; malnutrition is an important epidemiologic association.

The cardinal manifestations of juvenile tropical pancreatitis are recurrent abdominal pain, followed by diabetes mellitus, and pancreatic calculi, and death in the prime of life. The management of this condition consists of the alleviation of abdominal pain, the treatment of diabetes, the prevention of complications and the correction of nutritional problems.

### Key Learning Point

#### Juvenile tropical pancreatitis

- ➔ Abdominal pain followed by diabetes in an emaciated teenager and the radiologic demonstration of calculi in the pancreatic duct are the hallmark of the disease.

## LIVER TRANSPLANTATION

Paediatric liver transplantation should be considered at an early stage in babies and children dying of end-stage liver failure. With increasing experience, there are fewer contraindications to liver transplantation. Liver transplantation for children with life-threatening acute or chronic liver disease has proven to be durable with high success rates. The majority of paediatric liver recipients can now expect to enjoy a good quality of life with normal growth and development. Life-long immunosuppressive therapy is required. The circumstances in which liver transplantation should be considered are:



- Chronic liver disease
- Liver based metabolic disorders
- Acute liver failure
- Unresectable hepatic tumours
- Poor quality of life due to chronic liver disorders

## INFECTIOUS DIARRHOEA IN CHILDHOOD

Diarrhoea is a common manifestation of infection of the GI tract and can be caused by a variety of pathogens including viruses, parasites and bacteria. The most common manifestations of such infections are diarrhoea and vomiting, which may also be associated with systemic features such as abdominal pain, fever, etc. Although several non-infectious causes of diarrhoea are well recognised, the bulk of childhood diarrhoea relates to infectious disorders.

### Epidemiology of Childhood Diarrhoea

Despite considerable advances in the understanding and management of diarrhoeal disorders in childhood, these still account for a large proportion (18%) of childhood deaths globally with an estimated 1.9 million deaths. Although the global mortality of diarrhoea has reduced, the overall incidence remains unchanged with many children in developing countries averaging about 3.2 episodes per child year.

Although information on aetiology specific diarrhoea mortality is limited, it is recognised that rotavirus infections account for at least one-third of severe and potentially fatal watery diarrhoea episodes, with an estimated 4,40,000 deaths in developing countries. A similar number may also succumb to *Shigella* infections especially *S. dysenteriae* type 1 infections. In other parts of the world periodic outbreaks of cholera also account for a large number of adult and child deaths. The peak incidence of diarrhoea as well as mortality is among 6–11 months old infants.

Although there is very little information on the long-term consequences of diarrhoeal diseases, recent data suggest that diarrhoeal illnesses especially, if prolonged, may significantly impair psychomotor and cognitive development in young children.

### Aetiology of Diarrhoea

The major factor leading to infectious diarrhoea is infection acquired through the faeco-oral route or by ingestion of contaminated food or water. Hence this is a disease largely associated with poverty, poor environmental hygiene and development indices. Table 7.4 lists the common pathogens associated with diarrhoea among children. Enteropathogens that are infectious in a small inoculum [*Shigella*, *Escherichia coli*, enteric viruses, *Giardia lamblia*, *Cryptosporidium parvum* and *Entamoeba histolytica*] may be transmitted by person-to-person contact, whereas others such as cholera are usually a consequence of contamination of food or water supply. In developed countries episodes of infectious diarrhoea may occur by seasonal exposure to organisms such as rotavirus or by exposure to pathogens in settings of close contact, e.g. in day care centres.

Table 7.5 details the incubation period and common clinical features associated with infection with various organisms causing diarrhoea. Globally *E. coli* is the most common organism causing diarrhoea followed by Rota virus, *Shigella* species and non-typhoidal *Salmonella* species.

### Risk Factors for Gastroenteritis

In addition to the obvious sources of environmental contamination and increased exposure to enteropathogens, there are a variety of factors that increase susceptibility to infection. These risk factors include young age, immune deficiency, measles, malnutrition and lack of exclusive or predominant breastfeeding. In particular, malnutrition has been shown to increase the risk of diarrhoea and associated

**Table 7.4:** Common pathogens causing diarrhoea in children

Bacteria producing inflammatory diarrhoea	Bacteria producing non-inflammatory diarrhoea	Viruses	Parasites
<i>Aeromonas</i>	Enterotoxigenic <i>E. coli</i>	Rotavirus	<i>G. lamblia</i>
<i>C. jejuni</i>	<i>Vibrio cholerae</i> 01 and 0139	Enteric adenovirus	<i>E. histolytica</i>
<i>Clostridium difficile</i>	Enteropathogenic <i>E. coli</i>	Astrovirus	<i>Balantidium coli</i>
Enteroinvasive <i>E. coli</i>	Enterotoxigenic <i>E. coli</i>	Norwalk agent-like virus	<i>C. parvum</i>
<i>E. coli</i> O157:H7	<i>V. parahaemolyticus</i>	Calicivirus	<i>Strongyloides stercoralis</i>
<i>Salmonella</i>	<i>S. aureus</i>		<i>Trichuris trichiura</i>
<i>Shigella</i>			
<i>Y. enterocolitica</i>			
<i>V. parahaemolyticus</i>			
<i>C. perfringens</i>			

**Table 7.5:** Diarrhoea pathogens and clinical syndromes in children

Pathogen	Incubation period	Clinical features
Enteropathogenic <i>E. coli</i> (EPEC)	6–48 hours	Self-limiting watery diarrhoea, occasional fever and vomiting
Enteroinvasive <i>E. coli</i> (EIEC)	1–3 days	Watery diarrhoea, occasionally bloody diarrhoea
Enteraggregative <i>E. coli</i> (EAEC)	8–18 hours	Watery, mucoid diarrhoea. Bloody diarrhoea in a third of cases
Enterohemorrhagic <i>E. coli</i> (EHEC)	3–9 days	Abdominal pain, vomiting, bloody diarrhoea, haemolytic uraemic syndrome in 10% of cases
Enterotoxigenic <i>E. coli</i> (ETEC)	14–30 hours	Watery diarrhoea, fever, abdominal pain and vomiting
Diffusely adherent <i>E. coli</i>	6–48 hours	Mild watery diarrhoea
<i>Shigella</i>	16–72 hours	Mucoid and Bloody diarrhoea (may be watery initially), fever, toxicity, tenesmus,
<i>Y. enterocolitica</i>	4–6 days	Watery or mucoid diarrhoea (bloody in < 10%) with abdominal pain, fever, bacteraemia in young infants
<i>Campylobacter</i>	2–4 days	Abdominal pain (frequently right sided), watery diarrhoea (occasionally mucoid and bloody), fever
Rotavirus	1–3 days	Mostly in young children. Typically watery diarrhoea with upper respiratory symptoms in some children. May cause severe dehydrating diarrhoea

mortality several folds. The risks are particularly higher with micronutrient malnutrition. To illustrate, in children with vitamin A deficiency, the risk of dying from diarrhoea, measles, and malaria is increased by 20–24%. Likewise, zinc deficiency increases the risk of mortality from diarrhoea, pneumonia and malaria by 13–21%.

It is recognised that most diarrhoeal disorders form a continuum, with the majority of cases resolving within the first week of the illness. However, a smaller proportion of diarrhoeal illnesses may fail to resolve and persist for longer duration. Persistent diarrhoea has been defined as episodes that began acutely but lasted for at least 14 days and identifies a subgroup of children with a substantially increased diarrhoeal burden and between 36% and 54% of all diarrhoea-related deaths. Such episodes may account for between 3% and 20% of all diarrhoeal episodes in children under 5 years of age and up to half of all diarrhoea-related deaths.

### Clinical Manifestation of Diarrhoea

Most of the clinical manifestations and clinical syndromes of diarrhoea are related to the infecting pathogen and the dose/inoculum. A number of additional manifestations depend upon the development of complications (such as dehydration and electrolyte imbalance) and the nature of the infecting pathogen. Usually the ingestion of pre-formed toxins (such as those of *S. aureus*) is associated with the rapid onset of nausea and vomiting within 6 hours with possible fever, abdominal cramps, and diarrhoea within 8–72 hours. Watery diarrhoea and abdominal cramps after an 8–16 hour incubation period are associated with enterotoxin-producing

*Clostridium perfringens* and *B. cereus*. Abdominal cramps and watery diarrhoea after a 16–48 hour incubation period can be associated with calicivirus, several enterotoxin-producing bacteria, *Cryptosporidium* and *Cyclospora*. Several organisms including *Salmonella*, *Shigella*, *Campylobacter jejuni*, *Yersinia enterocolitica*, *enteroinvasive E. coli* and *Vibrio parahaemolyticus* are associated with diarrhoea that may contain foecal leukocytes, abdominal cramps and fever, although these organisms can cause watery diarrhoea without fever. Bloody diarrhoea and abdominal cramps after a 72–120 hour incubation period are associated with infections due to *Shigella* and also Shiga toxin-producing *E. coli* such as *E. coli* O157:H7.

Although many of the manifestations of acute gastroenteritis in children are non-specific, some clinical features may help identify major categories of diarrhoea and could facilitate rapid triage for specific therapy (Table 7.5). However, it must be underscored that there is considerable overlap in the symptomatology and if facilities and resources permit, the syndromic diagnosis must be verified by appropriate laboratory investigations. Table 7.6 indicates some of the features that help characterise diarrhoea severity and associated dehydration.

### Complications

Most of the complications associated with gastroenteritis are related to the rapidity of diagnosis and of institution of appropriate therapy. Thus unless early and appropriate rehydration is provided, most children with acute diarrhoea would develop dehydration with associated complications. In young children such episodes can be life-threatening. In other

**Table 7.6:** Clinical features associated with dehydration

	<i>Minimal or none (&lt; 3% loss of body weight)</i>	<i>Mild to moderate (3–9% loss of body weight)</i>	<i>Severe (&gt; 9% loss of body weight)</i>
Mucous membrane	Moist	Dry	Parched
Eyes/Fontanelle	Normal	Sunken	Deeply sunken
Skin pinch	Normal	Skin pinch goes back slowly 1–2 sec	Skin pinch goes back very slowly > 2 sec
Tears	Present	Decreased	Absent
Extremities	Perfused	-/+ delayed cap. Refill	Delayed cap. refill > 2 sec Cold, mottled
Mental status	Well, Alert	Normal, Irritable, lethargic	Lethargic, apathetic, unconscious
Pulse volume/ Heart rate	Normal	Rapid	Thready, Weak, impalpable
BP	Normal	Decreased	Hypotensive or unrecordable (in shock)
Urine output	Normal	Decreased	Absent for > 8 hr
Breathing	Normal	Fast	Rapid/Deep

instances, inappropriate therapy can lead to prolongation of the diarrhoeal episodes with consequent malnutrition and complications such as secondary infections and micronutrient deficiencies such as those with iron and zinc.

## Diagnosis

The diagnosis of gastroenteritis is largely based on clinical recognition of the disorder, an evaluation of its severity by rapid assessment and confirmation by appropriate laboratory investigations.

### *Clinical Evaluation of Diarrhoea*

The most common manifestation of GI tract infection in children is with diarrhoea, abdominal cramps, and vomiting. Systemic manifestations are varied and associated with a variety of causes. The following system of evaluation in a child with acute diarrhoea may allow a reasonably rapid assessment of the nature and severity of the disorder.

- Assess the degree of dehydration and acidosis and provide rapid resuscitation and rehydration with oral or intravenous fluids as required.
- Obtain appropriate contact or exposure history to determine cause. This can include information on exposure to contacts with similar symptoms, and intake of contaminated foods or water, childcare centre attendance, recent travel to a diarrhoea endemic area, use of antimicrobial agents.
- Clinically determine the aetiology of diarrhoea for institution of prompt antibiotic therapy. Although nausea and vomiting are non-specific symptoms, they are indicative of infection in the upper intestine. Fever is suggestive of an inflammatory process and also occurs as a result of dehydration. Fever is common in patients with inflammatory diarrhoea, severe abdominal pain

and tenesmus are indicative of involvement of the large intestine. Features such as nausea and vomiting, absent or low grade fever with mild to moderate periumbilical pain and watery diarrhoea are indicative of upper intestinal tract involvement.

### *Stool Examination*

Microscopic examination of the stool and cultures can yield important information on the aetiology of diarrhoea. Stool specimens should be examined for mucus, blood, and leukocytes. Foecal leukocytes are indicative of bacterial invasion of colonic mucosa, although some patients with shigellosis may have minimal leukocytes at an early stage of infection, as do patients infected with Shiga toxin-producing *E. coli* and *E. histolytica*. In endemic areas stool microscopy must include examination for parasites causing diarrhoea such as *G. lamblia* and *E. histolytica*.

Stool cultures should be obtained as early in the course of disease as possible from children with bloody diarrhoea, in whom stool microscopy indicates foecal leukocytes, in outbreaks, with suspected haemolytic ureamic syndrome (HUS), and in immunosuppressed children with diarrhoea. Stool specimens for culture need to be transported and plated quickly and if the latter is not quickly available, may need to be transported in special media. The yield and diagnosis of bacterial diarrhoea can be significantly improved by using molecular diagnostic procedures such as PCR techniques and probes.

### Treatment

A clinical evaluation plan and management strategy for children with moderate to severe diarrhoea as per the WHO/UNICEF IMCI strategy is outlined in Figures 7.16 and 7.17. The broad principles of management of acute diarrhoea in children include the following as given below.

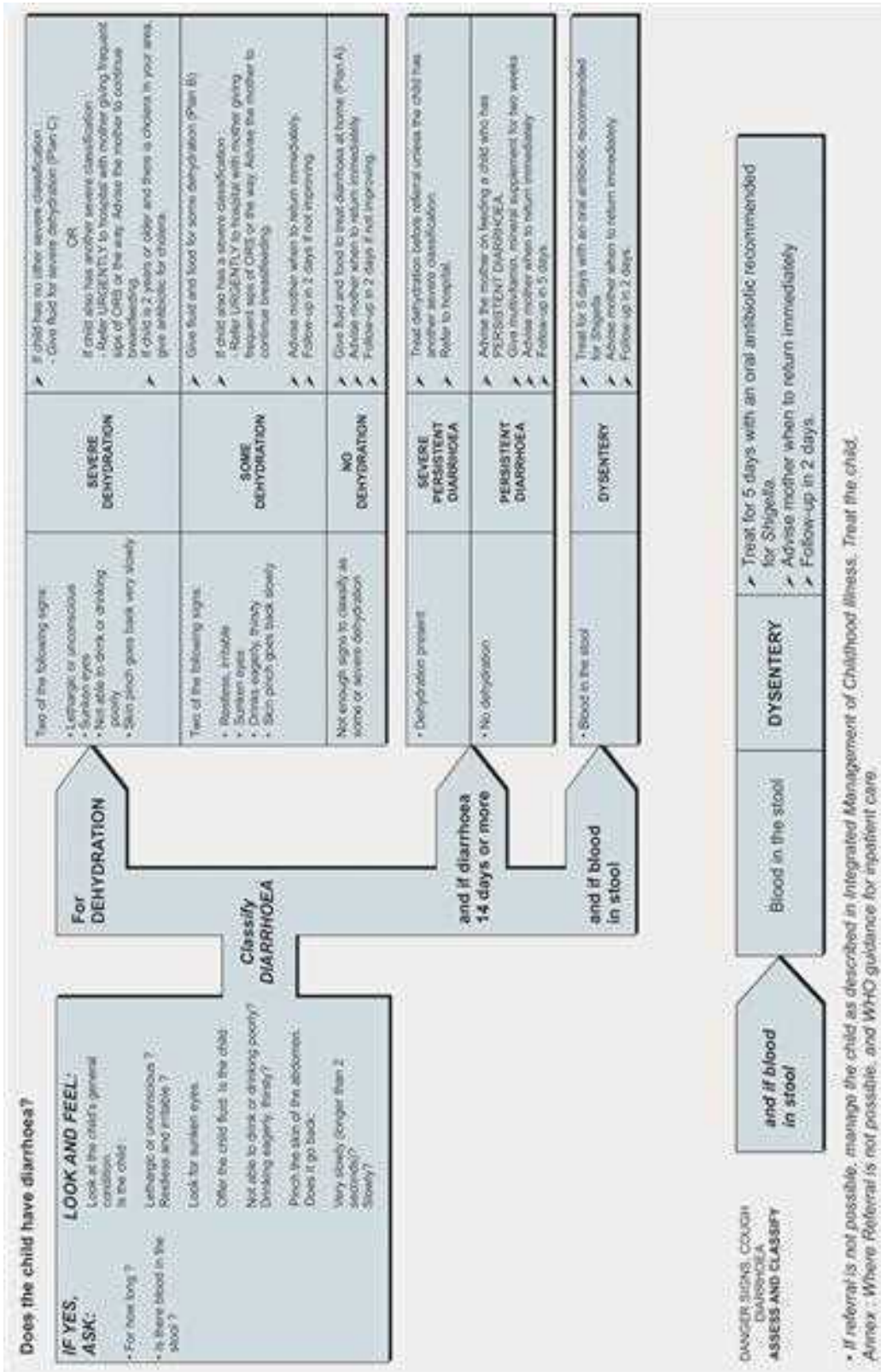


Fig. 7.16: IMCI protocol for the recognition and management of diarrhoea

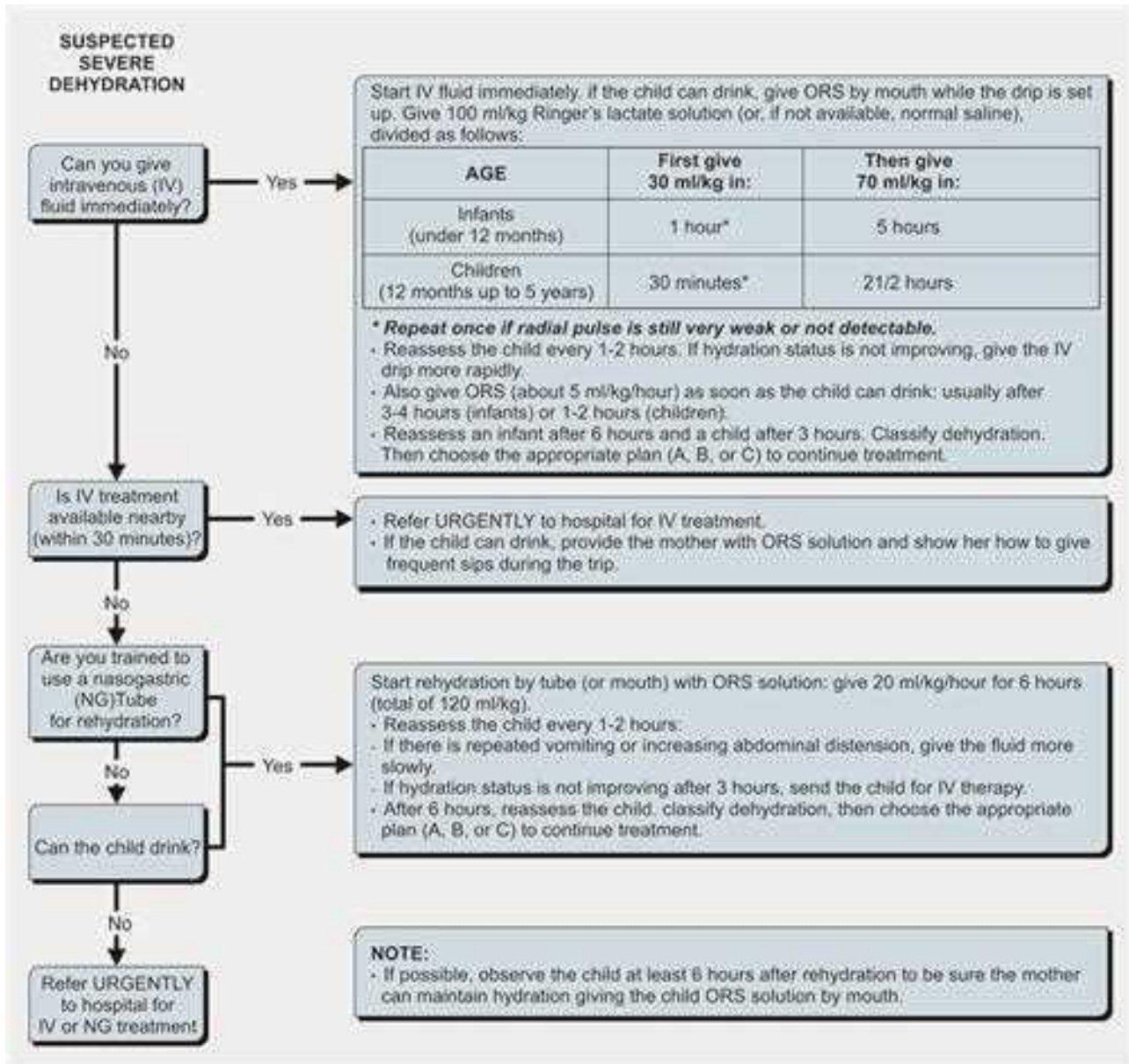


Fig. 7.17: Management of severe dehydration

### Oral Rehydration Therapy

Children, especially infants, are more susceptible than adults to dehydration due to the greater basal fluid and electrolyte requirements per kilogram and because they are dependent on others to meet these demands. This must be evaluated rapidly and corrected within 4–6 hours according to the degree of dehydration and estimated daily requirements. A small minority, especially those in shock or unable to tolerate oral fluids, may require intravenous

rehydration but oral rehydration is the preferred mode of rehydration and replacement of on-going losses. While in general the standard WHO oral rehydration solution (ORS) is adequate, recent evidence indicates that low-osmolality oral rehydration fluids may be more effective in reducing stool output. Compared with standard ORS, lower sodium and glucose ORS (containing 75 milliequivalents of sodium and 75 millimoles of glucose per litre, with total osmolarity of 245 milliosmols per litre) reduces stool output, vomiting, and the need for intravenous fluids.

### Enteral Feeding and Diet Selection

It is now well recognised that continued enteral feeding in diarrhoea aids in recovery from the episode and thus continued appropriate feeding in diarrhoea is the norm. Once rehydration is complete, food should be reintroduced while oral rehydration can be continued to replace ongoing losses from stools and for maintenance. Breastfeeding of infants should be resumed as soon as possible. The usual energy density of any diet used for the therapy of diarrhoea should be around 1 kcal/g, aiming to provide an energy intake of minimum 100 kcal/kg per day and a protein intake of between 2–3 g/kg per day. With the exception of acute lactose intolerance in a small proportion with diarrhoea, most children are able to tolerate milk and lactose containing diets. Thus in general withdrawal of milk and replacement with specialised (and expensive) lactose-free formulations

is unnecessary. Administration of a lactose load exceeding 5 g/kg per day is associated with higher purging rates and treatment failure in children with diarrhoea and alternative strategies for feeding such children may include the addition of milk to cereals as well as replacement of milk with fermented milk products such as yogurt.

Rarely when dietary intolerance precludes the administration of cow's milk based formulations or milk, it may be necessary to administer specialised milk-free diets such as a comminuted or blenderised chicken-based diet or an elemental formulation. It must be pointed out that although effective in some settings, the latter are unaffordable in most developing countries. In addition to rice-lentil formulations, the addition of green banana or pectin to the diet has also been shown to be effective in the treatment of persistent diarrhoea. Figure 7.18 indicates a suggestive algorithm for the management of children with prolonged diarrhoea.

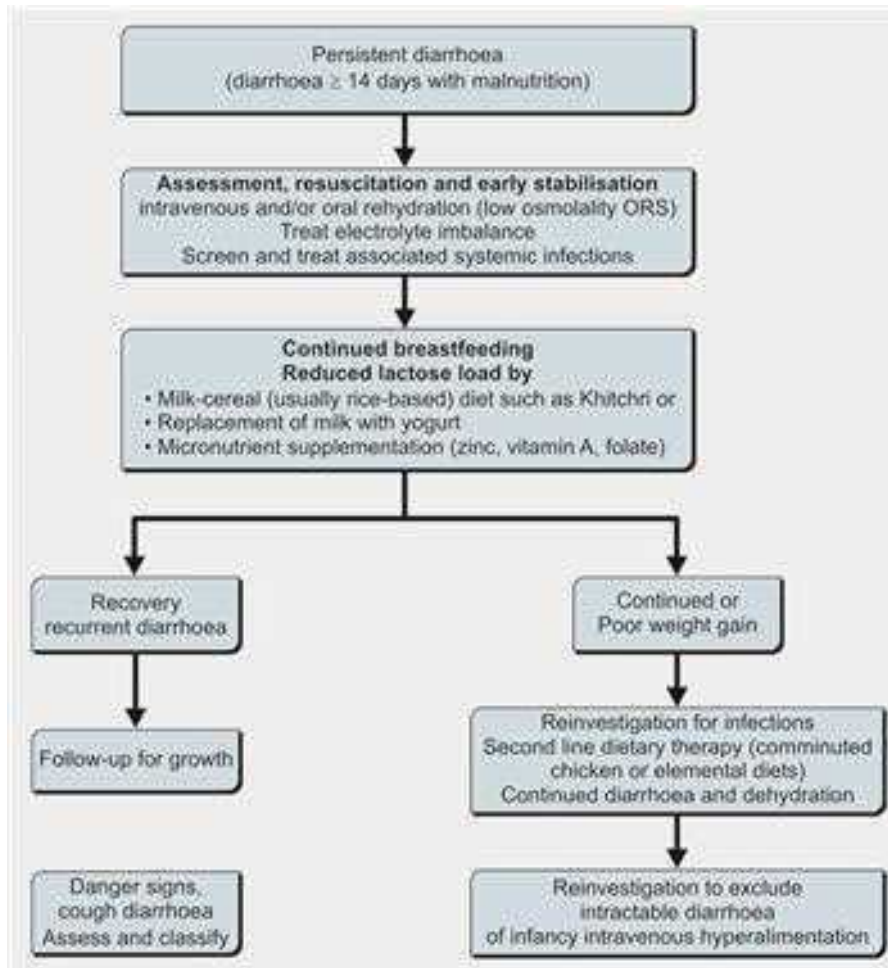


Fig. 7.18: Algorithm for the management of children with prolonged diarrhoea

**Table 7.7:** Antibiotic therapy for infectious diarrhoea

Organism	Drug of Choice	Dose and Duration of Treatment
<i>Shigella</i> (severe dysentery and EIEC dysentery)		Ciprofloxacin = 20–30 mg/kg per day divided bid for 7–10 days
EPEC, ETEC, EIEC	Trimethoprim sulfamethoxazole	10 mg/kg per day of TMP and 50 mg/kg per day of SMX divided bid for 5 (TMP/SMX) or ciprofloxacin days 20–30 mg/kg per day qid for 5–10 days
<i>C. jejuni</i>	Erythromycin or azithromycin	50 mg/kg per day divided qid for 5 days
<i>G. lamblia</i>	Metronidazole	30–40 mg/kg per day divided tid for 10 days
<i>E. histolytica</i>	Metronidazole	30–40 mg/kg per day divided tid for 7–10 days
<i>Cryptosporidium</i> species	Paromomycin or azithromycin	25–35 mg/kg per day divided tid for 5–10 days
<i>E. histolytica</i>	Metronidazole followed by iodoquinol	Metronidazole 30–40 mg/kg per day divided tid x 7–10 days
<i>Blastocystis hominis</i>	Metronidazole or iodoquinol	Metronidazole 30–40 mg/kg per day divided tid x 7–10 days

(Abbreviations: EIEC—enteroinvasive *E. coli*; TMP—trimethoprim; SMX—sulfamethoxazole; bid—2 times a day; qid—4 times a day; tid—3 times a day)

### Zinc Supplementation

There is now strong evidence that zinc supplementation among children with diarrhoea leads to reduced duration and severity of diarrhoea and WHO and UNICEF now jointly recommend that all children (> 6 months of age) with acute diarrhoea should receive oral zinc in some form for 10–14 days during and after diarrhoea (10–20 mg per day).

### Appropriate Antimicrobial Therapy

Timely antibiotic therapy is critical in reducing the duration and severity of diarrhoea and prevention of complications. Table 7.7 lists the commonly recommended antibiotics for use in infections with specific pathogens. While these agents are important to use in specific cases, their widespread and indiscriminate use may lead to the development of antimicrobial resistance. There is no role for antisecretory or antimotility agents in the treatment of acute gastroenteritis in children.

### Preventive Strategies for Reducing Diarrhoea Burden and Improving Outcomes

In developing countries with high rates of diarrhoea in children, a wider approach to diarrhoea prevention is required in addition to improved case management. These include the following as given below.

#### Improved Water and Sanitary Facilities and Promotion of Personal and Domestic Hygiene

Diarrhoea is a disease of poverty and much of the reduction in diarrhoea prevalence in the developed world has been a result of improvement in standards of hygiene and improved water supply. Several studies show that handwashing promotion,

access to soap as well as water purification strategies can significantly reduce the burden of diarrhoea in population settings.

#### Promotion of Exclusive Breastfeeding

Exclusive breastfeeding protects very young infants from diarrhoea through the promotion of passive immunity and through reduction in the intake of potentially contaminated food and water. There is now evidence that even in HIV endemic populations in developing countries, exclusive breastfeeding may reduce the risk of mortality without enhanced rates of mother to child transmission of the virus through breast milk and so this recommendation is indeed universal.

#### Safe Complementary Feeding Practices

Complementary foods in developing countries are generally poor in quality and frequently heavily contaminated, and thus are a major predisposing factor for diarrhoea after weaning. Contamination of complementary foods can be potentially reduced through caregiver's education in hygiene and sanitation, improving home food storage and strategies such as fermentation.

#### Rotavirus Immunisation

Almost all infants acquire rotavirus diarrhoea early in life, and given the burden estimates of rotavirus infections and mortality, an effective rotavirus vaccine would have a major effect on reducing diarrhoea mortality in developing countries. Two recent Rotavirus vaccines have shown remarkable protective efficacy in diverse settings and are being incorporated in national vaccine strategies.

Other vaccines that could potentially reduce the burden of severe diarrhoea and mortality in young children are vaccines against *Shigella* and enterotoxigenic *E. coli* (ETEC).

## BIBLIOGRAPHY

1. Ashkenazi S. *Shigella* infections in children: new insights. *Semin Pediatr Infect Dis.* 2004;15:246-52.
2. Bhutta ZA, Black RE, Brown KH, et al. Therapeutic effect of oral zinc in acute and persistent diarrhea in children in developing countries: pooled analysis of randomized controlled trials. *Am J Clin Nutr.* 2000;72:1516-22.
3. Bhutta ZA, Ghishan F, Lindley K, et al. Persistent and chronic diarrhea and malabsorption: working group report of the second World Congress of Pediatric Gastroenterology, Hepatology, and Nutrition. *J Pediatr Gastroenterol Nutr.* 2004;Suppl 2:S711-6.
4. Bhutta ZA. Persistent diarrhea. In: Guandalini S (Ed). *Textbook of Gastroenterology.* Taylor and Francis; 2004.
5. Denno DM, Stapp JR, Boster DR, et al. Etiology of diarrhea in pediatric outpatient settings. *Pediatr Infect Dis J.* 2005;24:142-8.
6. Hahn S, Kim Y, Garner P. Reduced osmolarity oral rehydration solution for treating dehydration due to diarrhea in children: systematic review. *BMJ.* 2001;323:81-5.
7. Jones G, Steketee RW, Black RE, et al. "How many child deaths can we prevent this year?". *Lancet.* 2003;362:65-71.
8. O'ryan M, Prado V, Pickering LK. A millennium update on pediatric diarrheal illness in the developing world. *Semin Pediatr Infect Dis.* 2005;16:125-36.
9. Thapar M, Sanderson IR. Diarrhea in children: an interface between developing and developed countries. *Lancet.* 2004;363:641-53.



# Paediatric Cardiology

## INTRODUCTION

Disorders affecting the cardiovascular system in childhood can be either congenital or acquired in aetiology. Over the last 50 years, the congenital forms of heart disease have evolved from a group of conditions for which no treatment was available to a set of abnormalities, the vast majority of which are treatable if recognised early.

As a group, heart disorders constitute the most common congenital abnormality with incidences quoted between 6/1,000 and 9/1,000. In the developed world, the incidence seems to be declining largely as a result of increased foetal diagnosis and subsequent termination of pregnancy. This effect, however, appears less marked in Asia.

The aetiology of congenital heart disease remains poorly understood. It is well-known that many syndromic abnormalities have associated with heart defects, and that exposure to certain drugs or toxic agents *in utero* can result in malformations of the heart (Table 8.1). The incidence of congenital heart disease is also known to be higher in siblings or offspring of those already affected. The incidence rises from 6–9/1,000 to 30–40/1,000 for siblings of affected children. Unfortunately the genetic basis for this remains largely unknown despite intense ongoing research.

Of the acquired forms of heart disease in childhood, those resulting from rheumatic fever remain the most common in Asia. Conversely, rheumatic heart disease is now rare in the developed world, where viral infections and endocarditis are the most common types of acquired heart disease.

Congenital heart disease can be classified in a number of ways. From a clinical view, they are usually split into acyanotic and cyanotic groups before further subdividing on the basis of precise anatomical diagnosis (Table 8.2). Acyanotic congenital heart disease is by far the most common group, comprising ventricular septal defect (VSD), atrial septal defect (ASD), atrioventricular septal defect (AVSD), arterial duct coarctation of the aorta, pulmonary stenosis and

congenital heart disease. The principal cyanotic lesions are tetralogy of Fallot, transposition of the great arteries (TGA), pulmonary atresia (PA<sub>t</sub>), tricuspid atresia and Ebstein's anomaly, altogether comprising about 5% of congenital heart disease. Other rare conditions such as total anomalous pulmonary venous drainage (TAPVD), hypoplastic left heart syndrome (HLHS) and other forms of univentricular heart constitute the remaining 5%. Conveniently it is this classification author will use to discuss the individual lesions.

## GENERAL PRINCIPLES OF DIAGNOSIS

Despite the huge improvements in echocardiography (echo), there remains no substitute for accurate clinical assessment possibly aided by a 12-lead electrocardiogram (ECG). Echo should be used to confirm and refine the clinical diagnosis, and then for follow-up assessment of abnormalities. The ECG remains an extremely important adjunct to the history and clinical examination. It is a simple, cheap, noninvasive tool that can often confirm or refute a diagnosis. The routine use of a chest X-ray is more controversial. Whilst more widely available than echo, it does involve a radiation dose and should probably be confined to children where the suspicion of heart disease is high, and the availability of echo low.

## EXAMINATION

### Inspection

A complete cardiovascular examination should start with careful inspection of the child asking five questions.

1. Is the child breathless? If a child is breathless as a result of a cardiac abnormality, it suggests pulmonary vascular engorgement, usually caused by heart failure (Table 8.3). This may result from increased pulmonary blood flow as in the case of a left to right intracardiac shunt—VSD, patent ductus arteriosus (PDA) and AVSD—or due to pulmonary venous engorgement—mitral regurgitation, dilated cardiomyopathy, obstructed total anomalous

**Table 8.1:** Conditions associated with congenital heart disease

Association	Defect(s)
<i>Chromosomal abnormality:</i>	
Trisomy 21	VSD, AVSD (in 50%)
Trisomy 18	VSD, PDA, pulmonary stenosis (in 99%)
Trisomy 13	VSD, PDA, dextrocardia (in 90%)
5p-/Cri-du-chat	VSD, PDA, ASD (in 25%)
XO (Turner)	Coarctation, aortic stenosis, ASD (in 35%)
XXXXY (Klinefelters)	PDA, ASD (in 15%)
<i>Syndrome:</i>	
Noonan	Dysplastic pulmonary stenosis
Williams	Supravalve aortic stenosis, branch pulmonary stenosis
DiGeorge	VSD, tetralogy, truncus, aortic arch abnormality
CHARGE	VSD, tetralogy
VACTERL	VSD, tetralogy
Holt-Oram	ASD
Friedreich's ataxia	Hypertrophic cardiomyopathy, heart block
Apert	VSD, tetralogy
Ellis-van Creveld	Common atrium
Pompe's (GSD II)	Hypertrophic cardiomyopathy
Leopard	Pulmonary stenosis, cardiomyopathy, long PR interval
Muscular dystrophy	Dilated cardiomyopathy
Tuberous sclerosis	Cardiac rhabdomyomata
Pierre Robin	VSD, PDA, ASD, coarctation, tetralogy
Long QT syndrome	Long QT interval and torsades de pointes
<i>Maternal conditions:</i>	
Rubella	PDA, branch pulmonary stenosis
Diabetes	VSD, hypertrophic cardiomyopathy (transient)
SLE (anti-Ro/La positive)	Congenital heart block
Phenylketonuria	VSD
Lithium	Ebstein's anomaly
Sodium valproate	Coarctation, HLHS
Phenytoin	VSD, coarctation, mitral stenosis
Alcohol	VSD

**Table 8.2:** Classification of congenital heart disease in childhood

<i>Acyanotic defects</i>
<i>Increased pulmonary blood flow:</i>
Atrial septal defect
Ventricular septal defect
Atrioventricular septal defect
Patent arterial duct
<i>Normal pulmonary blood flow:</i>
Pulmonary stenosis
Aortic stenosis
Coarctation of the aorta
<i>Cyanotic defects</i>
<i>Normal or reduced pulmonary blood flow:</i>
Tetralogy of Fallot
Transposition of the great arteries
Critical pulmonary stenosis
Ebstein's anomaly
Pulmonary atresia
Tricuspid atresia
Single ventricle with pulmonary stenosis
<i>Increased pulmonary blood flow:</i>
Total anomalous pulmonary venous drainage
Hypoplastic left heart syndrome
Truncus arteriosus
Single ventricle without pulmonary stenosis

**Table 8.3:** Causes of heart failure by age

First week	– Left heart obstruction (HLHS, aortic stenosis, coarctation), arrhythmia
First month	– Left to right shunt (VSD, AVSD, PDA, truncus arteriosus), arrhythmia
Thereafter	– Rheumatic fever, dilated cardiomyopathy, myocarditis, endocarditis, arrhythmia

2. Is the child cyanotic? Although the absence of clinical cyanosis does not exclude cyanotic congenital heart disease, if it is present, it limits the potential diagnoses to a relatively small group of abnormalities. In the newborn, most commonly it would suggest TGA or severely obstructed pulmonary blood flow (tetralogy of

atresia). In infancy, tetralogy is the most common cause, although transposition with VSD and other rare forms of complex congenital heart disease can also present at this age. In older children, a presentation with cyanosis would suggest pulmonary vascular disease complicating a VSD or PDA. Untreated, the high pulmonary pressures ultimately irreversibly damage the pulmonary vasculature resulting in high pulmonary resistance and a reversal of the intracardiac shunt (right to left) with subsequent cyanosis. This is known as Eisenmenger's syndrome. Rarely tetralogy and other complex forms of congenital heart disease can present in later life.

3. Is the child dysmorphic? Many children with congenital

of which are outlined in Table 8.1. Prompt recognition of a syndrome may alert the clinician to search for a particular abnormality.

4. Is the child failing to thrive? There are many causes of failure to thrive in infancy of which heart disease is a relatively minor one. The predominant groups of cardiac disorders causing poor weight gain are those resulting in breathlessness and poor feeding. These include VSD, AVSD and PDA. Whilst some children with cyanotic abnormalities also fail to grow this is far less common.
5. Does the child have any thoracic scars? If the child has had previous heart surgery, the type of scar may give clues to its nature. A median sternotomy scar suggests an open-heart procedure during which the heart would have been stopped and opened. All major intracardiac abnormalities requiring a surgical repair are corrected in this manner. A right lateral thoracotomy scar is usually only used for a right modified Blalock-Taussig shunt. During this procedure a tube is interposed between the right subclavian artery and the right pulmonary artery, providing an alternative source of pulmonary blood flow in children who have an obstructed native pulmonary blood flow (tetralogy of Fallot, PAt, tricuspid atresia). A left thoracotomy scar is used in the repair of aortic coarctation, ligation of patent arterial ducts, a left Blalock-Taussig shunt and occasionally a pulmonary artery band (a ligature placed around the main pulmonary artery to protect the lungs from high pressures in children with large VSDs).

## Palpation

Always start the examination by feeling the femoral and brachial pulses simultaneously. A reduction in volume or absence of the femoral pulse is strongly suggestive of coarctation of the aorta and should prompt closer examination and investigation. Although classically textbooks talk of radiofemoral delay this really only becomes appreciable as the child reaches adult size. Some children who have had previous procedures have an absent femoral pulse on one side only. It is, therefore, advisable to examine both femoral pulses.

Palpation for an enlarged liver should then be undertaken. The liver enlarges in heart failure and can reach below the

umbilicus in some children. The liver is often quite soft and difficult to feel in infants, particularly if the child is struggling so great care must be taken.

The heart enlarges in response to any chronic volume load. This may arise because of a right to left shunt—ASD, VSD, PDA and AVSD—because of valve dysfunction—mitral regurgitation, aortic regurgitation and pulmonary regurgitation—or because of a primary myocardial abnormality—viral myocarditis and dilated cardiomyopathy. In younger children, this can be felt as a sub-xyphoid heave by palpating just below the inferior end of the sternum. Children of all ages with a volume loaded heart may have a parasternal heave felt with the palm of the hand on the left side.

Finish off palpation by carefully placing your index finger in the suprasternal notch feeling for a thrill. If one is present, it is strongly suggestive of aortic stenosis, although rarely pulmonary stenosis and a PDA can produce this sign.

## Auscultation

Auscultation is often difficult in children. The combination of fast heart rate, noisy breathing and a poorly cooperative child make it the most challenging part of the examination. To ensure nothing is missed you should follow a fixed pattern when listening to a child's heart. I would suggest listening with the diaphragm at all points over the left side of the praecordium, followed by the right upper sternal edge and at the back. At each point, it is important to listen to systole, diastole and the heart sounds in turn. All can provide vital diagnostic information that is easy to miss when distracted by a loud, obvious systolic murmur. Murmurs are classically graded to permit easy comparison, systolic murmurs out of 6 and diastolic out of 4 (Table 8.4).

A full discussion of the auscultatory findings associated with different abnormalities will follow under the specific conditions.

## Innocent Murmurs

By definition an innocent murmur has no associated with heart disease; however, it is an extremely common finding, reason for referral and some clarification is needed. Innocent murmurs can be heard in up to 80% of children at some point. They can cause considerable diagnostic confusion so if you are in doubt get a more experienced opinion. Innocent

**Table 8.4:** Grading of heart murmurs

Murmur	1	2	3	4	5	6
Systolic	Barely audible	Quiet	Easily audible	Associated with thrill	Audible without stethoscope	Audible from end of bed
Diastolic	Quiet	Easily audible	Associated with thrill	Audible without stethoscope		

murmurs, all have an otherwise normal cardiovascular examination, are always systolic, often vary with posture and usually have a characteristic quality. Some murmurs are soft, short and heard only at the left sternal edge, others have a typical vibratory quality much like humming and can be quite loud. These are known as Still's murmurs. A venous hum is also common, particularly when a child is examined standing up. It is heard beneath either clavicle and extends through systole into diastole sometimes sounding like an arterial duct. Unlike a duct, however, a venous hum disappears as a child rotates his head or is supine.

A positive diagnosis of an innocent murmur enables the examining doctor to be very reassuring with the family that the heart is structurally normal.

### Investigations

Many heart conditions result in failure to thrive in infancy; therefore, height and weight should always be measured and plotted on a centile chart. Where possible, to complete the examination the child's saturation should be measured using a pulse oximeter. When using this equipment care should be taken to ensure the child's peripheries are warm, well perfused and the oximeter should be left in place on the child for at least 30 seconds to allow stabilisation of the reading. Measurement of the right brachial blood pressure should be made using the correctly sized cuff for the child. If coarctation is a possibility, many advocate the comparison of blood pressure measurements between arm and leg. In author's experience he has found this comparison misleading and do not place great emphasis on its importance. If there is any suspicion of endocarditis, a urine sample should be analysed for haemolysed blood and proteinuria.

### Electrocardiography

Electrocardiography is a simple noninvasive tool that records the electrical activity of the heart. A study is performed by attaching recording electrodes to specific sites on the skin to obtain raw recordings of cardiac electrical activity. These recordings are then processed to produce recognised "leads" that are printed out for examination. The electrical activity associated with each heart beat can be seen as a sequence of waves denoted P, Q, R, S and T (Fig. 8.1). These different leads look at the heart from different aspects allowing information to be obtained from most areas. By analysing the electrical activity of the heart, the precise heart rate and rhythm can be identified, the electrical axis can be measured, as can the heights and durations of the various waves. These measurements give information about the size and thickness of the various heart chambers, areas of ischaemic or infarction, and about abnormalities of conduction that might predispose the child to arrhythmias.

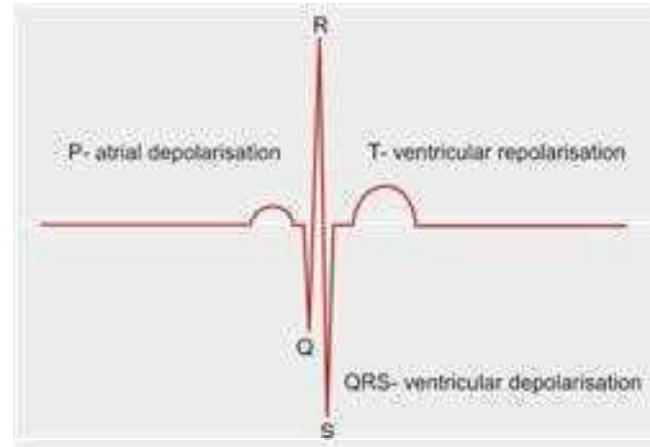


Fig. 8.1: ECG complex diagram

### Chest X-Ray

Where echo is available, a chest X-ray is not needed to make a diagnosis. However, it remains useful in assessing the severity of an abnormality and monitoring response to treatment. From a cardiac point of view, a chest X-ray provides information about the size of the heart, the pulmonary blood flow and about associated lung abnormalities.

An increased cardiothoracic ratio (over 0.6 in infancy and 0.55 in childhood) suggests enlargement of one or more chambers of the heart indicating volume loading or reduced function. Serial assessments of the cardiothoracic ratio may, therefore, provide information regarding change in severity of the problem over time or the effect of treatment.

Assessment of the pulmonary vasculature may provide information on the volume of pulmonary blood flow. This may be useful when assessing the significance of a moderate sized left to right cardiac shunt in a child; plethoric lung fields would indicate excessive pulmonary blood flow and, therefore, a haemodynamically significant abnormality. In a cyanosed newborn infant, oligoemic lung fields might suggest a cardiac lesion resulting in reduced pulmonary blood flow such as tetralogy of Fallot or PA.

The finding of associated lung abnormalities can give useful information about the significance of the heart lesion or otherwise. Collapse of the left lower lobe is particularly common in children with left atrial enlargement, aspiration due to gastro-oesophageal reflux disease is more common in breathless infants with cardiac problems and the finding of vertebral or rib abnormalities may suggest a generalised syndromic abnormality rather than an isolated cardiac problem.

### Echocardiography

Echocardiography is essentially ultrasound of the heart. The differences compared with conventional ultrasound are the

hardware and software settings that are configured to view the rapidly moving structures within the heart. Four main types of imaging are used that look at various aspects of cardiac function.

1. Two-dimensional or cross-sectional echo produces conventional ultrasound-type images of the heart structures moving in real time (Fig. 8.2). This modality facilitates accurate anatomical diagnosis of heart conditions by imaging how the various structures relate to each other.
2. M-mode echo takes a single line through the heart and plots all the information obtained against a time axis (Fig. 8.3). This mode is used for measurements and calculations particularly concerning ventricular function.
3. Doppler ultrasound measures the velocity of blood moving through the heart and great vessels. Using this data, it is possible to estimate pressure differences at various points in the heart such as across the aortic, pulmonary, mitral and tricuspid valves, a VSD or PDA and thus measure



Fig. 8.2: Normal parasternal long-axis echocardiogram

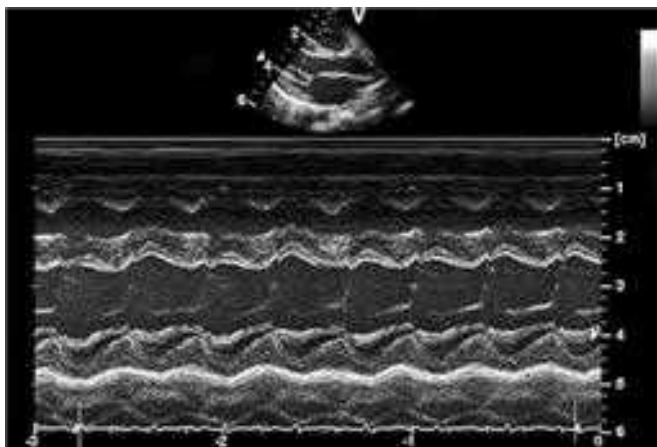


Fig. 8.3: Normal M mode echocardiogram through left ventricle

the severity of any narrowing or estimate the absolute pressure in a particular chamber.

4. Colour Doppler imaging superimposes Doppler information on blood flow on the moving 2-dimensional image of the heart. The technique uses different colours to represent both the direction of blood flow and its velocity (Fig. 8.4). This mode allows identification of valve leaks or heart defects that might not be seen on 2-dimensional imaging alone.

Echocardiography is now the mainstay of paediatric cardiac diagnosis. The availability of high quality machines at relatively low cost has expanded the routine use of this valuable technique such that it is now often undertaken by specialists in neonatology and general paediatrics as well as paediatric cardiologists.

### Cardiac Catheter

Cardiac catheterisation is both a diagnostic and treatment tool. Long thin plastic tubes (catheters) are introduced into a vein or artery and threaded through the various chambers of the heart. Direct pressure and oxygen saturation measurements are taken and radio-opaque contrast is injected into the heart to outline various structures and abnormalities. This technique has evolved over recent years to permit many common cardiac anomalies to be treated using this minimally invasive approach. Suitable ASDs, patent arterial ducts, VSDs, stenotic pulmonary and aortic valves as well as aortic coarctation can all be treated by the transcatheter route using specialised techniques.



Fig. 8.4: Colour flow Doppler echocardiogram demonstrating small mid-septal muscular ventricular septal defect

## CONGENITAL HEART ABNORMALITIES

### ACYANOTIC CONGENITAL HEART DISEASE

#### Ventricular Septal Defect

Ventricular septal defect is the most common congenital heart abnormality accounting for a fifth of all lesions. It is caused by a defect in the septum that divides the two ventricles. Defects can exist in the muscular septum (muscular defects) or in the membranous septum (perimembranous defects). The symptoms and signs result from the flow of blood between the two ventricles through the defect. At birth the resistance to flow through the lungs is equal to the resistance to flow to the body, i.e. the pulmonary vascular resistance (PVR) is equal to the systemic vascular resistance (SVR). Consequently little blood will pass through the VSD and no murmur will be audible. Over the first few days of life the PVR falls resulting in a drop in right ventricular pressure encouraging flow through a VSD and into the pulmonary circulation. When a VSD is present, blood can exit the left ventricle through both aorta and VSD increasing the required output of the left ventricle. The VSD flow will increase the overall pulmonary arterial flow and thus venous return to the left atrium (Fig. 8.5). The left heart, therefore, has to cope with increased volumes and enlarges producing a characteristic heave. Defects vary widely in size and position, as do the clinical features.

The majority of defects are small communications between the two ventricles through the perimembranous or muscular

septum. These usually present as asymptomatic murmurs and require only reassurance as most will close spontaneously and it is unlikely the remainder would ever need to be closed. Clinically small muscular defects can be recognised by the typical high-pitched, harsh, pansystolic murmur, often well localised over the left precordium. The exact position of the murmur is dependent on the location of the defect within the septum. The absence of a precordial or sub-xiphoid heave confirms the lack of a significant left to right shunt, and normal intensity of the second heart sound demonstrates normal pulmonary artery pressure. Small perimembranous defects can be indistinguishable from muscular defects, although the murmur tends to be higher on the left parasternal border. When a perimembranous defect is suspected the early diastolic murmur of aortic regurgitation must be excluded, as this would constitute an indication for repair.

Moderate sized defects, either muscular or perimembranous, usually have a louder murmur. With an increase in the volume of blood flowing through the defect, there is a corresponding increase in the stroke volume of the left ventricle producing a parasternal and sub-xiphoid heave. In large defects, blood flow through the VSD is less turbulent and the murmur will be quieter or even absent in completely unrestrictive defects. In these large defects, the heave is usually marked unless the PVR is elevated. With increasing size of defect, there is a proportional increase in the pulmonary artery pressure resulting in a loud pulmonary component of the second heart sound.

Infants with moderate to large defects develop the classical signs of heart failure as the PVR falls and the shunt

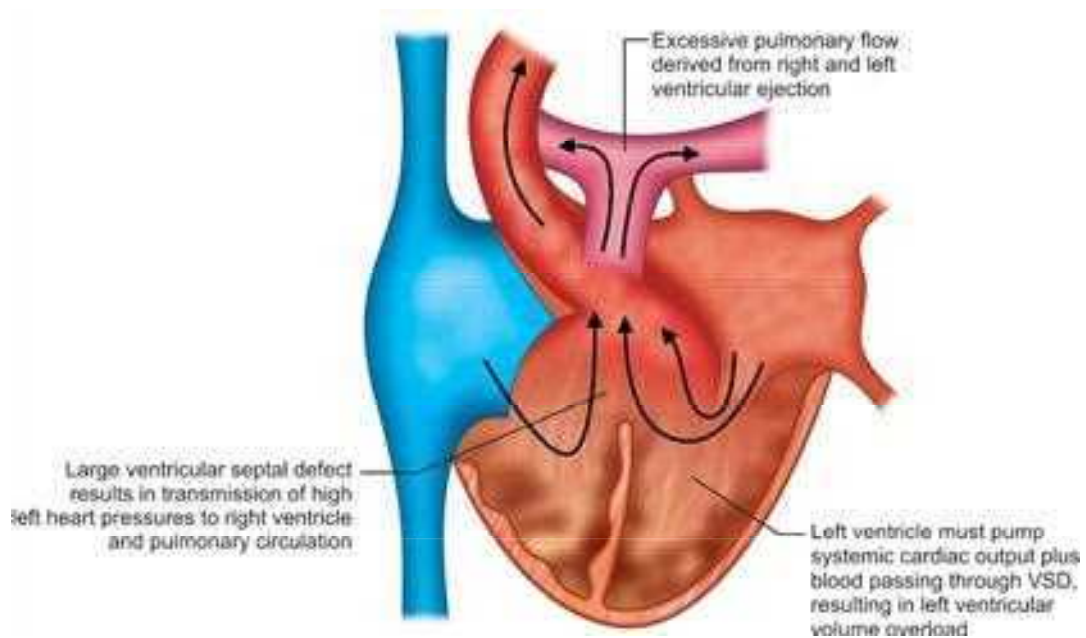


Fig. 8.5 Ventricular septal defect leading to excessive pulmonary flow.

increases. Typically they fail to thrive and feed poorly due to breathlessness and gut oedema. On examination they are tachypnoeic, tachycardic and sweaty have hepatomegaly a marked heave, variable systolic murmur, loud second heart sound and a summation gallop (combined third and fourth heart sounds producing a noise similar to a horse galloping).

With a significant VSD, the ECG may show evidence of biventricular hypertrophy and a sinus tachycardia. The chest X-ray will show cardiomegaly and plethoric lung fields. Diagnosis can be confirmed by echocardiogram which will demonstrate the position and size of the defect, exclude or confirm additional lesions, measure the size of the left ventricle which will reflect the degree of left to right shunt, and using Doppler estimate the right ventricular pressures to demonstrate any pulmonary hypertension.

### Management

**Large defects:** Treatment is aimed at stabilisation of the infant and encouragement of growth prior to surgical repair. The mainstays of therapy include nasogastric feeding to maximise caloric intake and minimise the energy expended during feeding. Medical therapy can be used to treat the symptoms of the intracardiac shunt and include diuretics treat the compensatory salt and water retention that is a consequence of heart failure, angiotensin-converting enzyme (ACE) inhibitors such as captopril reduce left ventricular afterload and encourage systemic flow. Digoxin can be used to combat excessive tachycardia and maximise myocardial efficiency. Caution should be exercised when using oxygen as it can cause pulmonary vasodilatation effectively worsening heart failure. Where infants have respiratory distress in the presence of a significant VSD, continuous positive airway pressure (CPAP) with high flow air may be of benefit by increasing the intra-alveolar pressure to avoid end-expiratory collapse whilst avoiding excessive pulmonary vasodilation and subsequent increase in intracardiac shunt.

Ultimately the majority of children with large defects will require surgical closure of the defect. Where open cardiac surgery is available, repair will usually be undertaken within 6 months to prevent the development of pulmonary vascular disease. Where only closed procedures are possible a pulmonary artery band can be applied to protect the lungs from excessive blood flow and high pressure, permitting later closure.

Children with small to moderate defects may need no therapy at all, if the haemodynamic shunt is small. Others may slowly develop left heart overload and require repair later in life, a number of these being suitable for transcatheter closure using one of the growing number of catheter

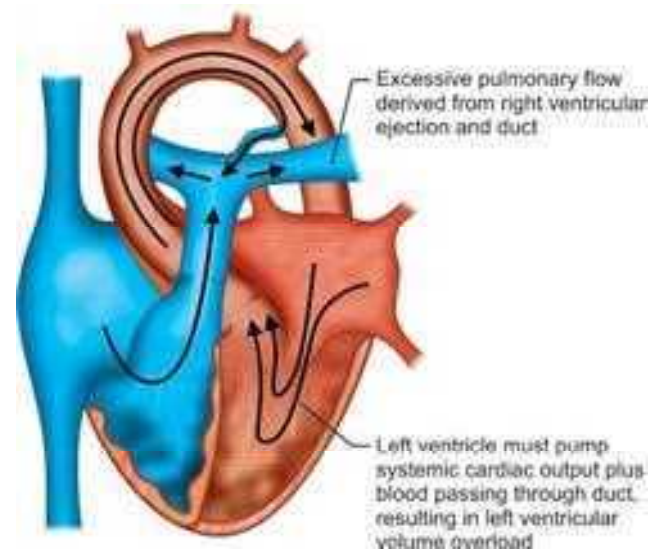
deployable devices. A small number of children with sub-aortic defects will develop aortic regurgitation, which is an indication for repair.

Untreated infants with large defects may die, usually from concomitant respiratory infections. Alternatively the symptoms may resolve from 6 months onwards as PVR increases due to inflammation and thickening of the pulmonary arterioles. These changes usually become irreversible at approximately 6–12 months, tending to slowly worsen thereafter. When the effective PVR becomes greater than the SVR the haemodynamic shunt through the VSD will reverse and the child will become cyanosed. This situation is known as Eisenmenger's syndrome and will not improve with correction of the original cardiac defect.

### Patent Ductus Arteriosus

The arterial duct is a vital foetal structure that connects the main pulmonary artery to the aorta. *In utero*, it allows blood to pass directly to the aorta from the pulmonary artery avoiding the high resistance pulmonary circulation. This “right to left” shunt exists because the PVR exceeds the SVR. At birth the rise in blood oxygen concentration together with a reduction in circulating prostaglandins usually causes spasm of the duct with eventual permanent closure. Ongoing patency of the duct beyond the immediate neonatal period results in the development of a “left to right” shunt from aorta to pulmonary artery as the PVR drops (Fig. 8.6). The significance of this varies depending upon the size of the child and size of the duct.

Preterm infants have an increased risk of PDA. In this group, the flow of blood through the duct results in excessive



**Fig. 8.6:** Patent ductus arteriosus—diagram demonstrating left heart volume overload



**Fig. 8.7:** Patent ductus arteriosus—colour Doppler echocardiogram

pulmonary blood flow, increased pulmonary venous return to the left heart, with subsequent chamber enlargement.

The infant is often breathless and may have high ventilation requirements which can result in ventilator induced lung disease. They will have high volume pulses, a left precordial heave and a systolic or continuous murmur. Term infants with a significant PDA may present with failure to thrive, together with signs of left heart overload and a murmur. The murmur is continuous (extends throughout systole and into diastole), heard best below the left clavicle and has a “machinery” character. Usually older children have small, asymptomatic ducts that are detected either during routine auscultation at a medical check or during an echocardiogram undertaken for an unrelated problem.

Because the haemodynamic effects are similar to those seen in a child with a VSD, the ECG and chest X-ray findings are similar. Echocardiogram allows an appreciation of the size of the duct (Fig. 8.7), as well as assessment of the shunt by the left heart chamber size (often comparing the left atrium to the aorta) and the pulmonary artery pressure using Doppler.

### Management

Preterm infants with large ducts require duct closure. This can often be accomplished using non-steroidal anti-inflammatory drugs, the most frequently used of which is intravenous indomethacin (three to six doses, 0.1–0.2 mg/kg, 12–24 hours apart). Intravenous ibuprofen has also been used recently with similar success rates and a lower adverse effect rate. If these drugs fail to achieve permanent closure, surgical ligation can be used with a high success rate and low complication rate. In symptomatic children beyond term the duct can be closed either surgically or more commonly by the transcatheter route. Prior to closure symptomatic improvement can be achieved by the use of diuretics with or without digoxin. In the asymptomatic child, closure is only

done to reduce the risk of endocarditis, as the possibility of left heart enlargement is small. In children where there is no murmur and the PDA is only detected by echocardiogram, no treatment (including antibiotic prophylaxis) is indicated.

### Atrial Septal Defect

Isolated ASDs rarely cause symptoms in childhood. The most common type of ASD is the secundum defect, which is formed by a gap in the centre of the atrial septum. Less common is the primum type (also called a partial or incomplete AVSD—see below), where a gap exists low down in the atrial septum adjacent to the mitral and tricuspid valves. In some primum defects, there is also a gap or cleft in the anterior mitral valve leaflet which can result in valve regurgitation. The left to right shunt at atrial level seen in ASD produces enlargement of the right heart (Fig. 8.8).

An ASD may produce no detectable signs; however, with a significant haemodynamic shunt, a heave can be present along with flow murmurs across the pulmonary (systolic) and rarely tricuspid (diastolic) valves. In addition, a characteristic fixed widely split second heart sound may be heard.

The ECG in a secundum defect will show right axis deviation whereas it will be leftward or superior with a primum defect. As the right ventricle enlarges, a partial right bundle branch block pattern will develop (RSR' in V4R and V1). The chest X-ray will reveal cardiomegaly resulting from enlargement of the right heart structures. Echo confirms size and position of the defect, excludes associated anomalies such as pulmonary valve stenosis and allows assessment of the shunt size by measuring the right ventricular size.

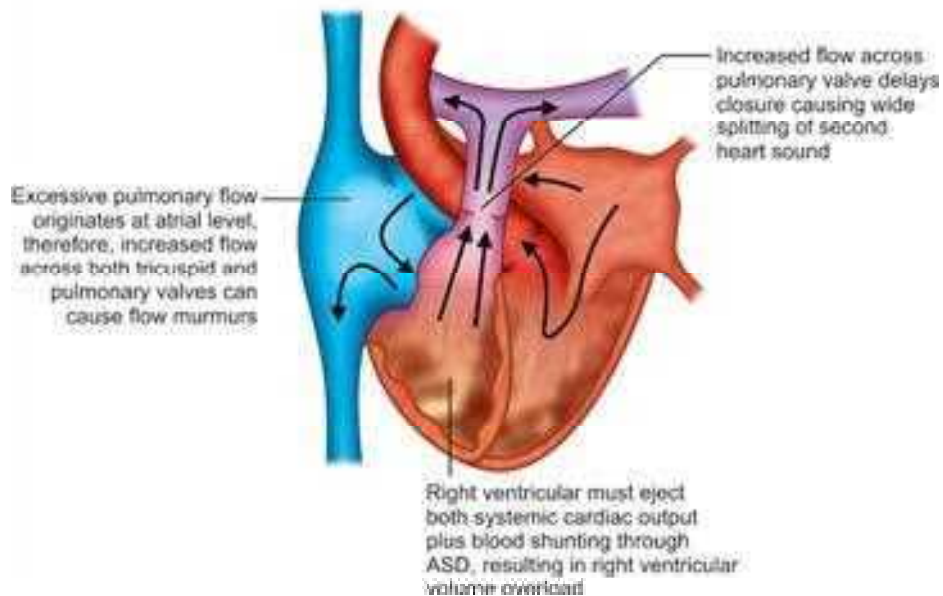
### Management

It is unusual for an ASD to produce symptoms in childhood and medical therapy is rarely required. Untreated a significant ASD will cause enlargement of the right ventricle with reduction in function and symptoms of reduced stamina and exertional dyspnoea. Chronic atrial enlargement can cause arrhythmias in adulthood. Unlike VSDs, spontaneous closure is rare and therefore closure is indicated where the ASD is felt to be haemodynamically significant as suggested by an increase in the right ventricular size. Interventional catheter techniques can now be used to close many secundum ASDs, although open surgery remains the only treatment for primum defects.

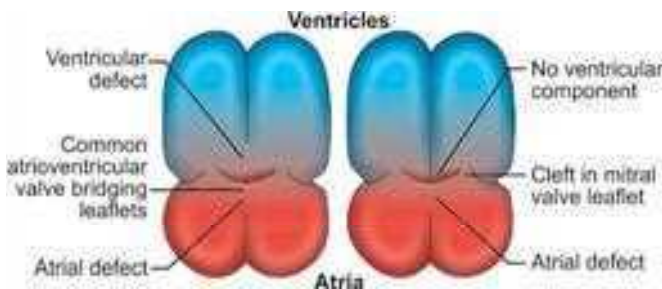
### Atrioventricular Septal Defect

AVSD results from a failure of fusion of the endocardial cushions in the centre of the heart. Defects are said to be complete where a ventricular defect is present and incomplete





**Fig. 8.8:** Atrial septal defect—diagram demonstrating right heart volume overload



**Fig. 8.9:** Atrioventricular septal defect—complete versus incomplete AVSD

inlet valves (tricuspid and mitral) are abnormal and usually composed partly of common (bridging) leaflets that sit across the septal defects. AVSDs are particularly common in Down's syndrome where they may be associated with tetralogy of Fallot.

Incomplete AVSD, as with all types of ASD usually presents as an asymptomatic murmur. An isolated atrial defect will cause right ventricular enlargement detectable as a precordial heave. The systolic and diastolic murmurs are similar to other forms of ASD; however, if there is significant mitral regurgitation through a cleft in the anterior mitral valve leaflet, left ventricular enlargement is likely together with an apical systolic murmur.

The presentation of complete AVSD will vary according to the size of the ventricular component. Small ventricular component defects present in a very similar way to incomplete AVSDs; however, it is more common for there to be a large

ventricular component which will present with symptoms of heart failure in a similar way to large VSDs. It is not surprising that it can often be difficult to distinguish clinically between VSD and AVSD.

The characteristic finding on electrocardiography is leftward or superior deviation of the QRS axis. This permits distinction from secundum ASD and VSD. Chest X-ray findings depend largely on the size of ventricular defect present and effective left to right shunt. Typically it will show an enlarged cardiac silhouette and plethoric lung fields.

### Management

No AVSD will resolve spontaneously and all need surgical repair. Where a child presents with heart failure due to a large ventricular component the medical management is as described for VSD. The timing of surgery depends on the lesion; large ventricular components need repair within the first 6 months whereas if the pulmonary artery pressures are normal, providing the mitral leak is not severe, surgery can often be deferred many years.

### Coarctation of the Aorta

A coarctation is an area of narrowing in the distal aortic arch that restricts flow to the lower half of the body. A coarctation occurs at the point at which the arterial duct inserts into the aorta, and it is likely that extension of ductal tissue into the aortic wall is responsible for the narrowing. Broadly speaking children with coarctation comprise two groups; (1) those that present with failure to thrive and (2) those that

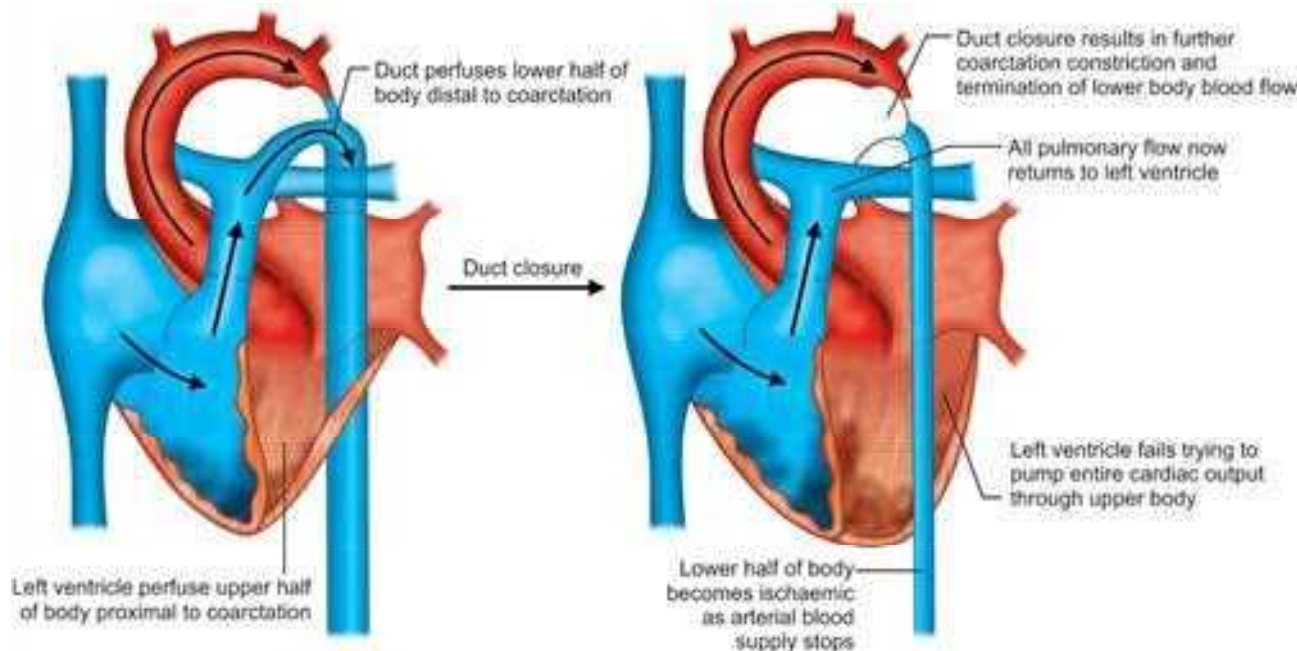


Fig. 8.10: Aortic coarctation—diagram demonstrating effect of duct closure

present as asymptomatic children or adults with a murmur or hypertension.

### Infants

The more severe forms of coarctation present within the first few weeks of life. In these, children closure of the duct results in subtotal or even complete obstruction to the aorta (Fig. 8.10). The left heart fails due to the sudden increase in afterload, the lower half of the body including liver, kidneys and gut become ischaemic and a severe metabolic acidosis rapidly ensues. There is a very short history of poor feeding, breathlessness and poor colour. The infant will be grey, peripherally shut down, poorly responsive, cold, tachypnoeic, tachycardic, sweaty, have absent femoral pulses, hepatomegaly, a summation gallop and may or may not have a murmur.

### Management

This situation constitutes a medical emergency. The child should be resuscitated and vascular access obtained by whatever means possible. As a priority the child should be started on a prostaglandin E (0.01–0.1  $\mu\text{g}/\text{kg}$  per minute) infusion as well as an intravenous inotrope (e.g. dopamine 5–20  $\mu\text{g}/\text{kg}$  per minute). Prostaglandin E is used to open the arterial duct and also reduce the severity of the coarctation by relaxing the ductal tissue that may extend into the aortic wall. An unfortunate effect of prostaglandin E is that it can cause apnoea at therapeutic doses and the child may need

Once the child has been resuscitated, a detailed assessment can be made including ECG, chest X-ray and echo to both confirm the clinical diagnosis and exclude any associated lesion. At this age, surgical repair is the only option and should take place as soon as the child is stable. Prostaglandin should not be discontinued until time of repair.

### Older Child

Older children or adults with coarctation, usually present at routine examination with either reduced femoral pulses or hypertension. The narrowing is usually milder and will have progressed over a longer period of time allowing the child's circulation to adjust by developing collateral arteries around the obstruction. In some smaller children, there may be a history of failure to thrive but usually they are symptom free. Examination will show a well, pink child with reduced or absent femoral pulses, a loud second heart sound and a systolic murmur heard over the back at the left hand side of the spine. In teenagers and adults, there may be a delay in the timing of the femoral compared to the radial pulse, so-called radiofemoral delay. Hypertension may be present and four-limb blood pressure recording may reveal an arm/leg gradient, although its absence does not exclude the diagnosis.

The ECG will show evidence of left ventricular hypertrophy, particularly if the coarctation is longstanding and chest X-ray may show characteristic features such as double aortic knuckle and rib notching (Fig. 8.11). An



**Fig. 8.11:** Aortic coarctation—chest X-ray showing double aortic knuckle and rib notching

of the severity and also excludes associated abnormalities such as a bicuspid aortic valve or a VSD.

### Management

Hypertension should be treated carefully, taking care not to reduce the blood pressure excessively as this may precipitate renal failure. Classically coarctation has always been repaired surgically; however, in teenagers and adults, balloon angioplasty with insertion of a Goretex Covered metal stent has become the treatment of choice in many large centres.

Following repair long-term surveillance is required to watch for restenosis and aneurysm formation at the site of repair. In the long-term patients with coarctation are at risk of hypertension and also intracerebral aneurysms.

### Aortic Stenosis

Obstruction of the left ventricular outlet usually occurs at the level of the valve. Less commonly a fibrous ring or membrane can cause sub-valve obstruction, and rarely the obstruction can occur above the valve (e.g. Williams syndrome associated with branch pulmonary stenosis, hypercalcaemia, mental retardation and elfin facies). Valve obstruction is more common in boys and results from either a bicuspid valve, or fusion of the valve cusps with or without dysplasia of the valve tissue. Whilst it is often an isolated lesion, severe aortic stenosis is a key feature of HLHS.

As with most lesions presentation depends on severity.

and produces no symptoms. It will only be detected in childhood as an asymptomatic murmur, usually preceded by a characteristic ejection click that helps to distinguish it from sub-aortic stenosis. The murmur is heard at the upper left sternal edge, radiates to the neck and is often associated with a thrill in the suprasternal notch. If severe obstruction occurs early in foetal life, it may progress to HLHS by the time of birth; however, more commonly severe aortic stenosis presents in the newborn period as a duct-dependent lesion (in such children the arterial duct permits blood to flow from right to left effectively providing or augmenting the systemic cardiac output) (Fig. 8.12). The child will be cyanosed, possibly with a drop in saturations between upper and lower limbs, and have the characteristic ejection systolic murmur and ejection click (short sharp sound heard immediately before the murmur). Upon closure of the duct the child may develop a low cardiac output state with poor pulses, cool peripheries, tachypnoea, tachycardia and hepatomegaly.

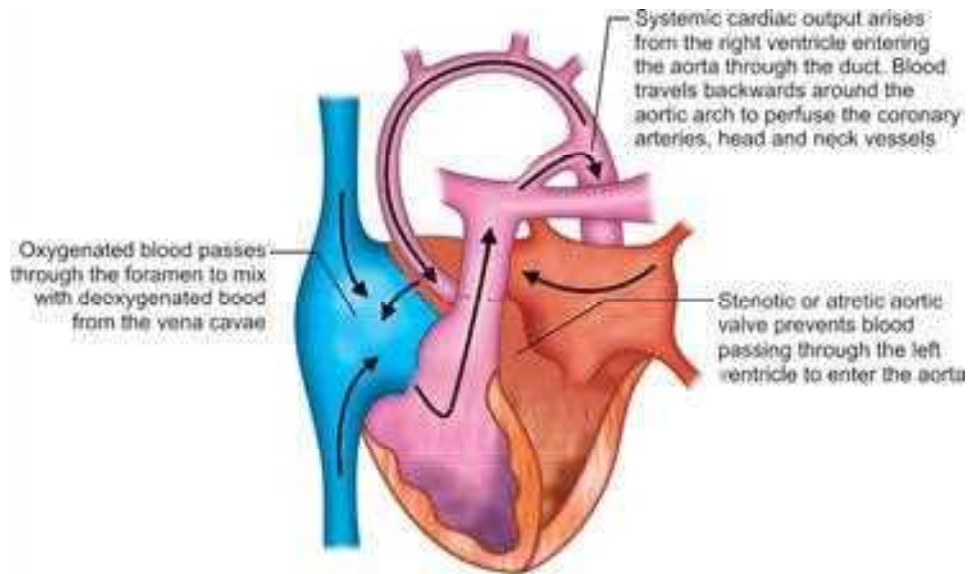
Children with moderate aortic stenosis usually present with an asymptomatic murmur. The degree of stenosis gradually progresses as the child grows causing exertional dyspnoea when severe angina or syncope. These late symptoms are associated with a risk of sudden death and require urgent investigation and treatment.

Although the chest X-ray may be normal even in quite severe aortic stenosis, the ECG will usually show evidence of left ventricular hypertrophy often with the characteristic ST changes of left ventricular strain (Fig. 8.13). ECG will confirm the diagnosis and also estimate its severity using Doppler. In addition, it will demonstrate any associated aortic regurgitation.

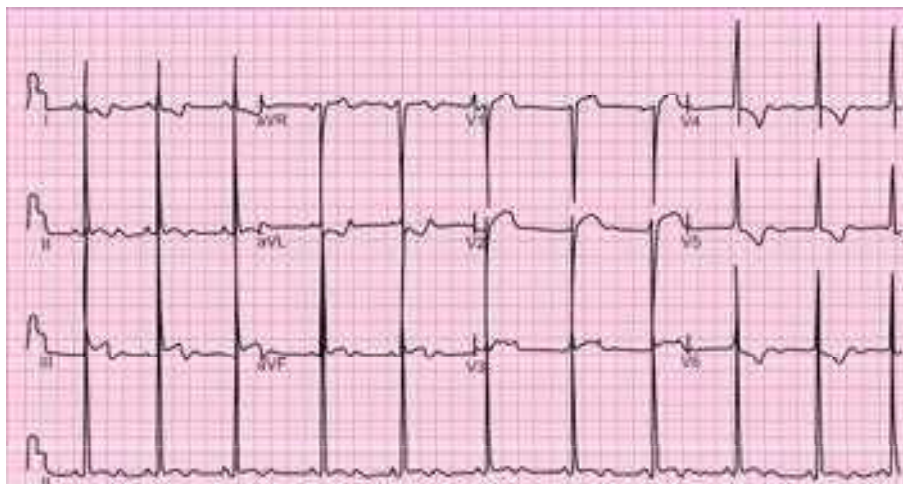
### Management

The indications for treating aortic valve stenosis are either symptoms (angina or syncope) or evidence of left ventricular hypertrophy and strain. Where a patient has symptoms directly attributable to the aortic stenosis they should be advised to restrict physical activity and avoid exertion. There is no form of medical treatment indicated and relief of obstruction can be achieved by balloon valvuloplasty, surgical valvotomy or valve replacement. Valvuloplasty and valvotomy are palliative procedures designed to relieve the obstruction temporarily to allow the child to reach adult size before they require a valve replacement. The uncontrolled nature of both techniques produces the risk of aortic valve regurgitation which although well tolerated will in time produce enlargement of the left ventricle requiring a valve replacement. Transcatheter aortic valve replacement is not yet a possibility in childhood.

Sub-aortic stenosis should be treated where there



**Fig. 8.12:** Duct-dependent systemic circulation



**Fig. 8.13:** ECG—left ventricular hypertrophy

on the ECG or aortic regurgitation on the echo. Surgical resection is the only treatment option currently available and unfortunately there is a risk of recurrence of the stenosis soon after repair.

### Pulmonary Stenosis

As with aortic stenosis, pulmonary stenosis most commonly occurs at the valve itself but can be seen below the valve (e.g. tetralogy of Fallot), above the valve or in the pulmonary

of the valve cusps and in isolation is a relatively common abnormality.

Mild pulmonary valve stenosis presents with an asymptomatic ejection systolic murmur and click. The murmur tends to be heard more to the left than with aortic stenosis, may radiate to the back and is not usually associated with a suprasternal thrill. The second heart sound is often quiet and a heave will only be present in the more severe lesions. Mild or even moderately severe pulmonary stenosis can improve in childhood, thus a “wait and see” approach is

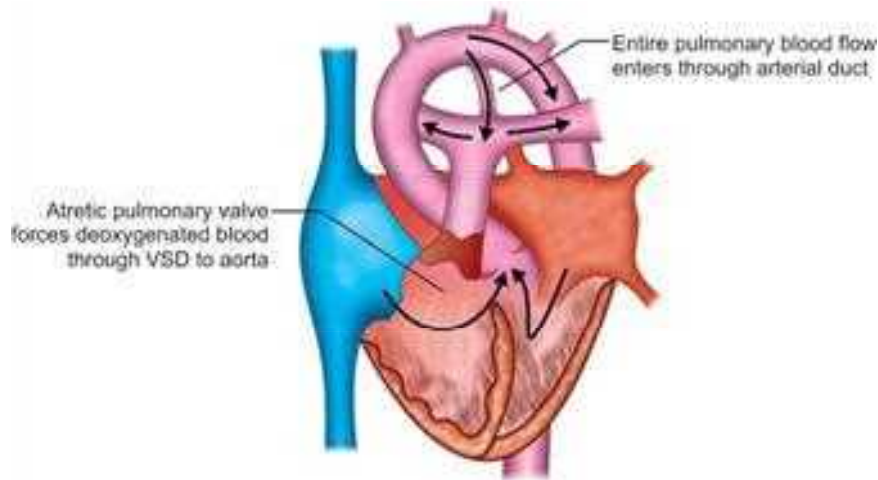


Fig. 8.14: Duct-dependent pulmonary circulation

Severe pulmonary stenosis will present in the newborn, lesion, as a duct-dependent lesion. Whereas in aortic stenosis the arterial duct allows the systemic circulation to be augmented by the pulmonary side, in pulmonary stenosis the converse is true and pulmonary blood flow is derived largely from the aorta (Fig. 8.14). Prior to the duct closure the infants will be cyanosed (due to a right to left shunt at atrial level), have a characteristic systolic murmur but be otherwise well. Duct closure will herald hypoxia, acidosis and an abrupt deterioration in the child.

The ECG will demonstrate right axis deviation and right ventricular hypertrophy. In more severe cases, P pulmonale and partial right bundle branch block will be present. Chest X-ray may show poststenotic dilation of the pulmonary artery as a bulge around the left hilum together with oligoemic lung fields. As with aortic stenosis, echo will confirm the diagnosis and estimate severity using Doppler. It will also confirm that the right ventricle has grown to a size that will support a normal biventricular circulation.

### Management

Transcatheter balloon valvuloplasty is now the treatment of choice for this lesion, producing good results with a very low requirement for re-intervention. The exception to this is in Noonan syndrome where the pulmonary valve is often severely thickened and classically unresponsive to valvuloplasty. In such cases, open surgical valvotomy is still indicated. Balloon valvotomy is generally a very effective treatment for this problem, although in newborns with severe obstruction, relief of the stenosis can precipitate dynamic sub-pulmonary obstruction which will usually resolve over a period of a few weeks.

## CYANOTIC CONGENITAL HEART DISEASE

### Tetralogy of Fallot

Tetralogy is the most common form of cyanotic congenital heart disease comprising up to 10% of all lesions. It is associated with Down's syndrome, deletions of chromosome 22 (DiGeorge syndrome) and VACTERL (vertebral defects, anal atresia, tracheo-oesophageal atresia, sacral aplasia, renal and limb abnormalities), although it usually occurs in isolation. Classically it was described as the tetrad of VSD, right ventricular outflow tract obstruction, aorta overriding the crest of the ventricular septum and right ventricular hypertrophy. In effect only two of these factors are important in the pathogenesis; a completely unrestrictive VSD and significant obstruction to pulmonary blood flow (Fig. 8.15).

Presentation depends on the degree of obstruction to pulmonary blood flow. The level of obstruction varies but usually comprises a degree of muscular sub-valve (infundibular) obstruction together with either valve or supra-valve stenosis. Because the VSD is large and does not restrict flow, if there is mild to moderate pulmonary obstruction, there will be no net flow through the VSD and the child will be in a balanced state, sometimes called a "pink tetralogy". With more severe obstruction deoxygenated blood will flow right to left across the defect resulting in cyanosis. The obstruction tends to progress as the infundibular muscle hypertrophy increases culminating in a behaviour known as "spelling". During a hypercyanotic spell without warning the cyanosis becomes acutely worse. This may occur when the child has just been fed, is falling asleep, waking up or when upset. It is likely a reduction in the SVR causes an increase in right to left shunt. This leaves the right ventricle underfilled permitting increased systolic contraction and worsening of the muscular sub-pulmonary

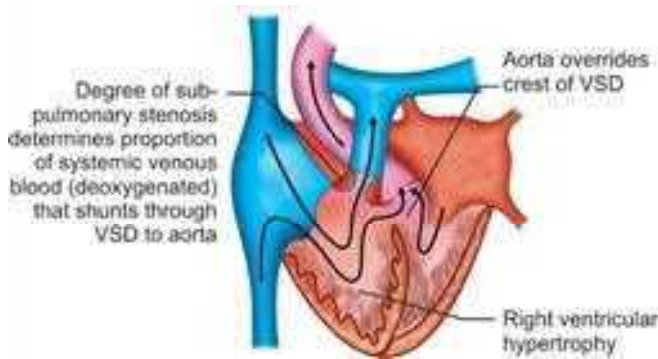


Fig. 8.15: Tetralogy of Fallot—diagram



Fig. 8.16: Chest X-ray, tetralogy of Fallot showing a “boot-shaped” heart with upturned apex and oligoemic lung fields

stenosis. The cycle is self-perpetuating and may result in hypoxic syncope and convulsions. Children with this problem often develop a behaviour known as squatting, during which they crouch down; effectively increasing the SVR as well as increasing venous return.

On examination infants with tetralogy have a characteristic ejection systolic murmur of pulmonary stenosis radiating through to the back with no ejection click. A right ventricular heave is invariably present. The degree of cyanosis varies in newborns, but tends to worsen as the child grows and if prolonged will result in clubbing of the digits and the plethoric facies of polycythaemia. The child's growth may be affected, although in isolated tetralogy weight gain is often normal. ECG demonstrates right axis deviation and right ventricular hypertrophy. Chest X-ray typically shows a “boot-shaped” heart with upturned apex and oligoemic lung fields (Fig. 8.16). The diagnosis together with the level and severity of the pulmonary obstruction can be determined by transthoracic echo, which can help to exclude associated

Untreated tetralogy has a poor prognosis. Progressive sub-pulmonary obstruction results in increasing cyanosis, poor exercise tolerance, increasingly frequent hypercyanotic spells and syncope. The obligatory right to left shunt also causes an increased susceptibility to brain abscesses.

### Management

The degree of cyanosis determines the timing of intervention. If a child is pink or only mildly desaturated at presentation, it is appropriate to keep them under observation and this can be at a regular out-patient review once the arterial duct closure is confirmed. The timing of repair in a well child with only mild to moderate cyanosis (oxygen saturations of 75% or above) is controversial. Many centres would now opt to repair at 6 months of age to minimise the amount of infundibular muscle that needs to be resected. Other centres prefer to defer elective surgery until a year of age by which time the child will be significantly larger.

Where a child presents with either more than moderate cyanosis (oxygen saturation of less than 75%) or hypercyanotic spells, surgical intervention is required. If the child has not reached the age at which that centre would opt for complete repair, a palliative procedure would be undertaken most commonly in the form of a modified Blalock-Taussig shunt. This procedure involves placing a Gore-Tex tube between the subclavian artery and the pulmonary artery, usually on the right side, allowing blood to flow into the pulmonary circulation irrespective of any intracardiac obstruction. Full repair requires closure of the VSD, resection of the sub-pulmonary muscle and enlargement of the pulmonary valve orifice. Where the pulmonary valve annulus is small a patch is required to enlarge it, unfortunately rendering it regurgitant and introducing the possibility that a pulmonary valve replacement will be required later in life. Although the repair can be complex and requires full cardiopulmonary bypass it now usually carries an operative mortality of less than 5%.

**Hypercyanotic spells:** When a child presents with a hypercyanotic spell, it is important not to panic in front of the mother or child. Calmly tuck the child's knees up to their chest and place them on the parent's chest in this tucked position. Waft oxygen into the child's face but try not to upset them. If this is ineffective then venous access must be obtained and the child given intravenous volume (10 ml/kg), morphine (100 µg/kg) and propranolol (10 µg/kg) intravenously. Once stabilised they can be commenced on propranolol 1 mg/kg three to four times per day until

## Transposition of the Great Arteries

Transposition of the great arteries is the most common cause of cardiac cyanosis in newborns. It is more common in male infants, and is not usually associated with any noncardiac abnormality.

In TGA, the pulmonary artery is connected to the left ventricle and the aorta to the right. Consequently deoxygenated blood circulates around the systemic circulation and oxygenated blood around the pulmonary circulation with mixing between the two circulations occurring through the foramen ovale and the arterial duct (Fig. 8.17). Following birth mixing continues and the child is usually well but cyanotic with an otherwise normal cardiovascular examination. When the duct shuts, mixing between the two circulations is only possible through the persistent foramen ovale (PFO) which is usually inadequate and so the child becomes hypoxic and acidotic. In this situation, the infant is unlikely to survive without urgent medical intervention.

When a VSD is present this may permit more than adequate mixing to the extent that the child may have oxygen saturations in the low nineties even after the duct has shut. The natural history of TGA/VSD differs from that of isolated TGA. Untreated the children may develop heart failure as the PVR drops but will develop severe hypoxia and so are unlikely to die in the newborn period.

Chest X-ray demonstrates a typical egg-on-side appearance with a narrow mediastinum and usually increased pulmonary vascularity, although oligoemia can be present (Fig. 8.18). ECG shows right axis deviation and right ventricular hypertrophy. Echocardiogram confirms the diagnosis in addition to showing patency of the arterial duct, adequacy of the foramen ovale, coronary artery positions and also any defects in the ventricular septum.

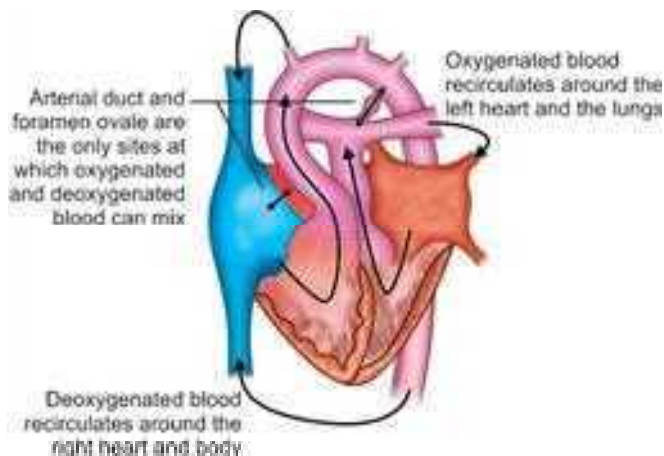


Fig. 8.17: Transposition of the great arteries—diagram



Fig. 8.18: Chest X-ray—transposition of the great arteries

## Management

If the infant is unwell, it is likely the arterial duct is narrow or closed. An infusion of prostaglandin E should be started urgently at a dose of 50–100 ng/kg per minute, accepting that the child may become apnoeic and require intubation. If the child improves at this dose, it can be reduced to 5–10 ng/kg per minute facilitating extubation. In addition to prostaglandin E, most infants will require augmentation of the foramen ovale by balloon atrial septostomy. This can be performed either through the umbilical vein or the femoral vein. A specialised balloon septostomy catheter is introduced into the right atrium and manipulated across into left atrium using echo guidance. Once in position the balloon is inflated with up to 4 ml of normal saline and jerked back across the septum using a sharp but controlled tug. The “jump” as the septum tears is usually palpable. Although the pullback may be repeated several times in practice once is often sufficient.

Surgical repair of transposition usually takes place at 1–2 weeks of life. This allows the infant to gain a little maturity, but does not permit the left ventricle to “detrain” by pumping to the low resistance pulmonary circulation for too long. The vast majority of infants with TGA now undergo an arterial switch procedure. This affords a complete anatomical repair by detaching the aorta, coronary arteries and pulmonary artery above the valve, and reanastomosing them to the anatomically appropriate ventricles. Where the coronary artery positions are favourable, this produces an excellent repair with a risk of less than 5% in most centres.

Although they may remain deeply cyanosed, many children will survive into infancy without an arterial switch providing an adequate septostomy has been performed.

## Tricuspid Atresia

This rare form of cyanotic congenital heart disease comprises less than 2% of all infants with a cardiac anomaly. Absence of normal RV filling *in utero*, results in poor development of the right ventricular cavity, although most infants have a moderate sized VSD allowing the pulmonary valve to develop reasonably well. Systemic venous return passes through the foramen ovale to mix with the pulmonary venous return before entering the left ventricle. The mixed blood then passes through the aortic valve to the systemic circulation where a proportion will pass to the pulmonary artery via a VSD or PDA (Fig. 8.19). In 30%, the great arteries are transposed and the aorta arises from the hypoplastic right ventricle. Some children, including all without a VSD, have significant obstruction to pulmonary blood flow and are duct dependent. Others have adequate flow through the VSD to the pulmonary circulation at birth; however, obstruction may develop rapidly in the first few weeks of life either at VSD level or in the sub-pulmonary area such that cyanosis becomes a major problem. A small number never develop obstruction and progress to heart failure when the PVR drops.

Usually cyanosis is obvious from birth and deepens with time. Such infants may fail to thrive, develop finger-clubbing and untreated are unlikely to survive more than 12 months. A systolic murmur at the mid left sternal edge may be present from the VSD or sub-pulmonary obstruction and the second heart sound will be single. Electrocardiography shows left axis deviation, which in a cyanotic child is virtually diagnostic of tricuspid atresia. Chest X-ray typically shows a “box” like cardiac silhouette with pulmonary oligoemia (Fig. 8.20). Echo will confirm the diagnosis and show with great detail the VSD and sub-pulmonary area. This allows a tentative prediction to be made regarding the development of obstruction to pulmonary flow.

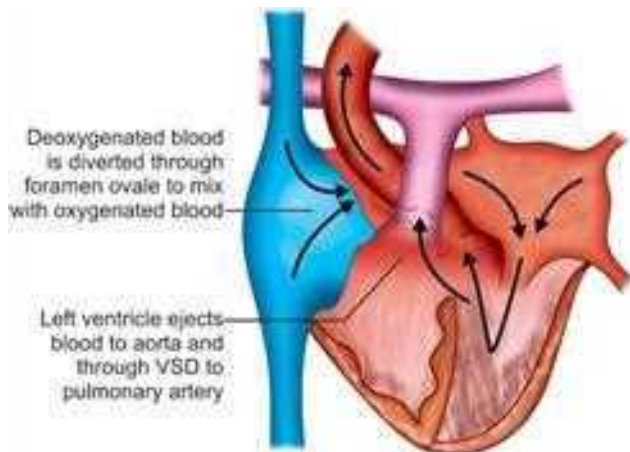


Fig. 8.20: Chest X-ray tricuspid atresia

### Management

Early palliation in excessively cyanotic infants is by a modified Blalock-Taussig shunt as described under tetralogy of Fallot. Further palliation follows the Fontan-type pattern and will be summarised later in the univentricular heart section.

### Total Anomalous Pulmonary Venous Drainage

This rare cyanotic abnormality accounts for less than 1% of all congenital heart disease; however, with recognition and early surgical repair, it is curable. Although there are three main forms, each with their own peculiarities, all share a common pathophysiology. In foetal life, the pulmonary venous confluence fails to fuse with the left atrium. The pulmonary veins drain to the heart, through either an ascending vein to the superior vena cava, a descending vein to the inferior cava or directly to the coronary sinus and right atrium (Fig. 8.21). As both pulmonary and systemic venous return enters the right atrium, these children are dependent on adequacy of the foramen ovale for the entire systemic cardiac output. Obstruction at this level or any other impairs, venous return causing a rise in pulmonary venous pressure with accompanying pulmonary hypertension and pulmonary oedema. Obstruction may be present in the first few hours of life (particularly in infracardiac TAPVD or TAPVC), can develop in the first few weeks as the PVR drops or may take many months to develop as the PFO becomes restrictive. If venous return is unobstructed, these infants have mild cyanosis, are slow to grow but often have no other physical signs. As obstruction develops cyanosis deepens and the child becomes acidotic causing tachypnoea and tachycardia. The infant will have hepatomegaly, a gallop rhythm and a



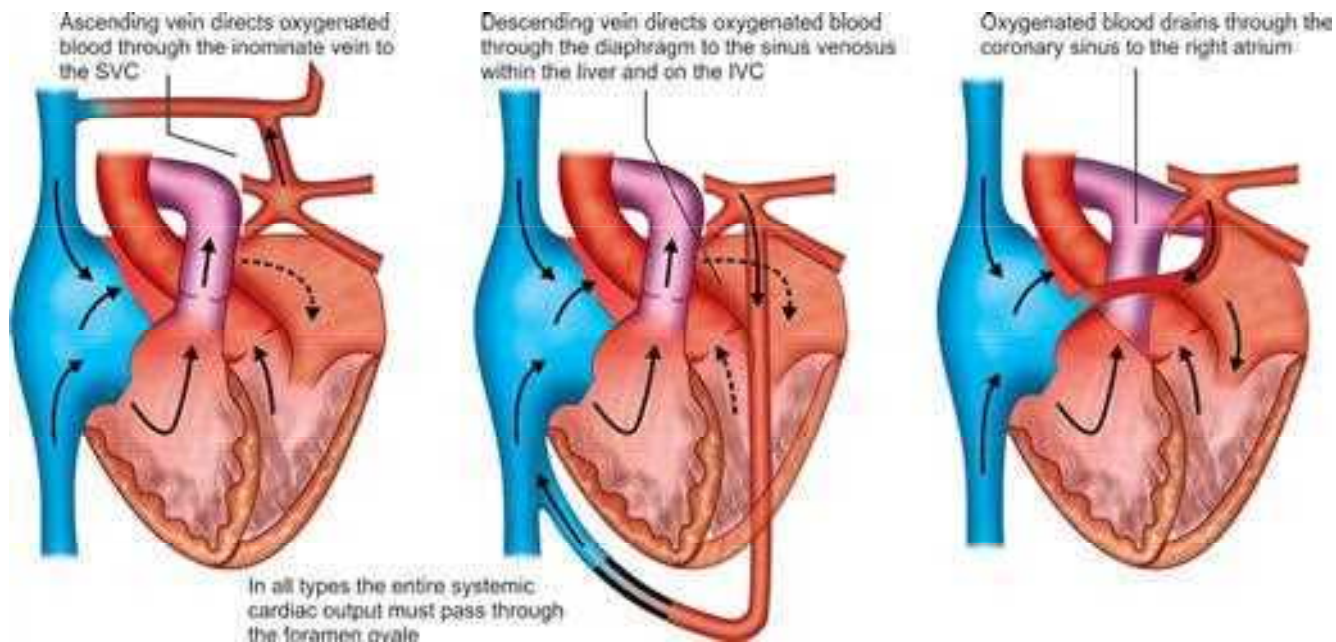


Fig. 8.21: Total anomalous pulmonary venous drainage—diagram

ECG demonstrates right axis deviation, right ventricular hypertrophy and P pulmonale. Chest X-ray shows pulmonary venous congestion and in chronic supracardiac TAPVD, the widened superior mediastinum gives the mediastinal silhouette a “figure of eight” appearance. Echo is usually diagnostic confirming the pattern of pulmonary venous drainage and demonstrating any area of obstruction.

### Management

There is no effective medical therapy and all children with this condition will eventually die without repair. A small percentage of children will go on to develop pulmonary vein obstruction even after successful early repair.

### Pulmonary Atresia

Pulmonary atresia is a widely varying condition; however, all infants are cyanosed and most are duct dependent. There are three main groups: (1) PA/intact ventricular septum (IVS), (2) PA/VSD and confluent pulmonary arteries and (3) PA/VSD and major aortopulmonary collateral arteries (MAPCAs) (Fig. 8.22).

All children are cyanosed at birth. The second heart sound will be single but there may be no murmurs unless MAPCAs are present in which case continuous murmurs are often heard throughout the chest.

Where no VSD is present, the absence of flow through the right ventricle *in utero* results in a hypoplastic right ventricle. Most children with this condition, require a modified Blalock-

type repair when older (discussed later). Some children with Pat/IVS have a reasonably well developed right ventricular cavity and tricuspid valve. This subgroup may benefit from re-establishing antegrade flow from the right ventricle to the pulmonary artery to encourage further growth of the right ventricle and potentially a biventricular repair.

Where a VSD is present and the pulmonary arteries are confluent, the child will still need initial palliation with a modified Blalock-Taussig shunt; however, at a later stage, the VSD can usually be closed and a tube interposed between the right ventricle and the pulmonary arteries. Both of these types of PA are duct-dependent requiring prostaglandin E<sub>1</sub> infusion to maintain ductal patency without which infants will die upon duct closure.

Prognostically the worst anatomy is PA with MAPCAs. In these children, MAPCAs arise directly from the aorta and supply individual segments of lung sometimes with little communication between them and any rudimentary main pulmonary artery. Extensive reconstructive surgery is often required to create a pulmonary artery confluence large enough to permit later insertion of a right ventricle to pulmonary artery conduit and VSD closure.

### Ebstein's Anomaly

In this rare abnormality, the tricuspid valve annulus has developed within the right ventricle itself. In effect part of the right ventricle functions as part of the right atrium, the right ventricular cavity volume is significantly reduced; the tricuspid

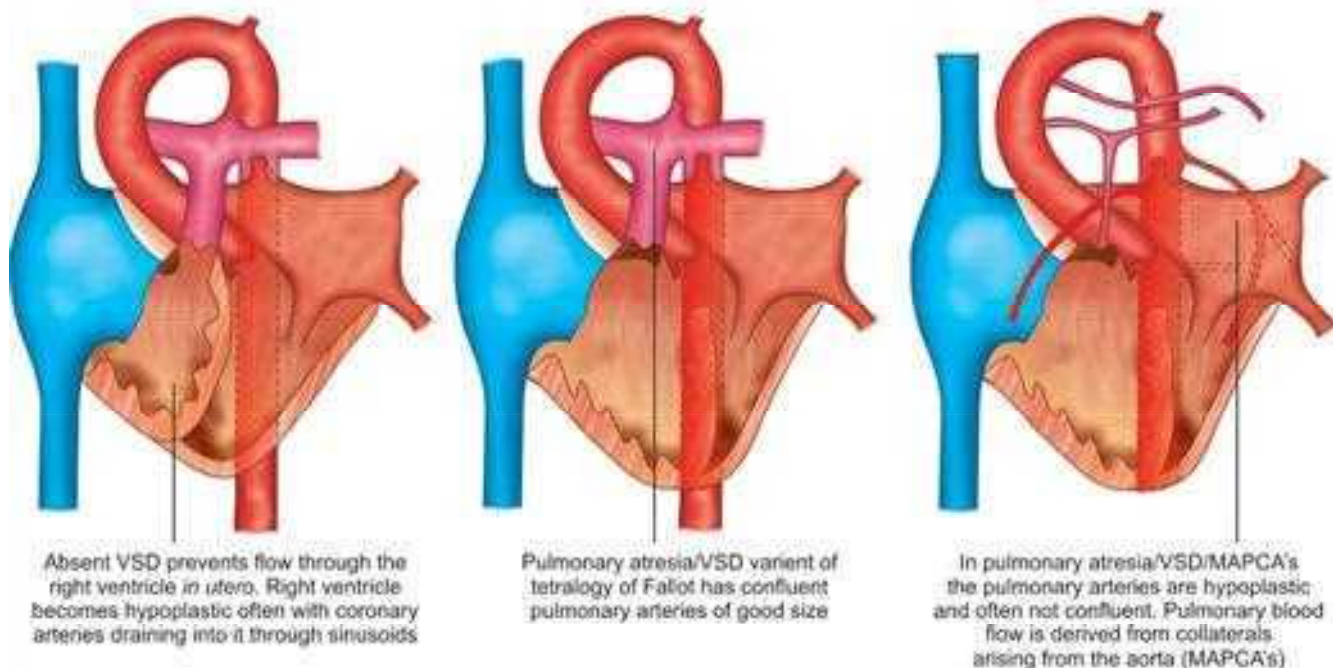


Fig. 8.22: Pulmonary atresia—variants diagram

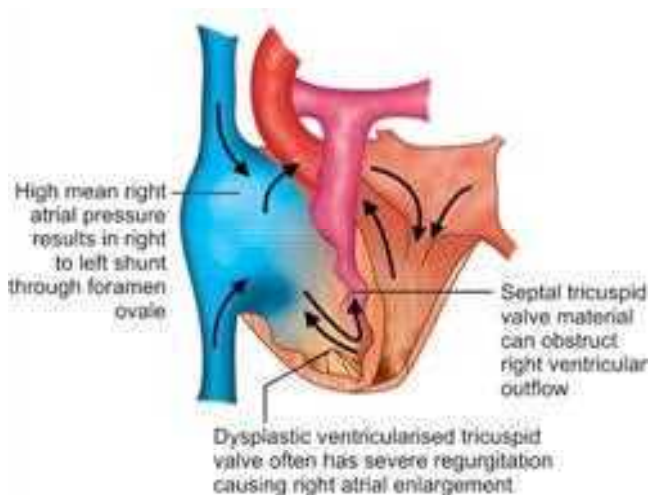


Fig. 8.23: Ebstein's anomaly—diagram

right ventricular outflow tract may be obstructed (Fig. 8.23). In severe cases, the abnormality causes huge enlargement of the right atrium *in utero* such that the sheer size of the heart impedes lung development and the child dies in the newborn period. In less severe cases, the pulmonary artery flow is obstructed and deoxygenated blood tends to shunt right to left across the atrial septum causing cyanosis and poor exercise ability. Mild cases are virtually asymptomatic and present late in life with either right heart failure or arrhythmias.

Clinically there is variable cyanosis and the neck veins

the tricuspid regurgitation. A systolic murmur and sometimes a late diastolic murmur are heard at the lower left sternal edge often with a gallop rhythm. The ECG shows notched P waves signifying right atrial enlargement, right bundle branch block (Fig. 8.24), and may reveal the short PR interval and delta wave of associated pre-excitation (Wolff-Parkinson-White syndrome). Chest X-ray often shows an increased cardiothoracic ratio, primarily due to right atrial enlargement and oligoemic lung fields. Echo will again confirm the diagnosis and help assess the degree of tricuspid regurgitation and atrial shunting.

### Management

Medical treatment is useful only for arrhythmia management. Surgical intervention is difficult and controversial with a significant risk. The exact procedure must be tailored to the individual case and will be determined mainly by the adequacy of the right ventricle.

### Hypoplastic Left Heart Syndrome and other Forms of Univentricular Heart

Hypoplastic left heart syndrome is the broad term given to describe inadequacy of the left ventricular size in combination with stenosis or atresia of the mitral and aortic valves and hypoplasia of the aortic arch. Coarctation is a common association. As with aortic stenosis, the systemic



**Fig. 8.24:** ECG Ebstein's anomaly

so duct constriction causes a low cardiac state with severe acidosis and hypoxia. Such children require resuscitation and prompt administration of prostaglandin E as described previously. Despite these measures, infants with HLHS cannot survive without radical surgical palliation in the form of a Norwood procedure. Briefly, this operation bypasses the left heart by removing the atrial septum, transecting the main pulmonary artery above the valve and connecting it to the systemic arterial circulation using a Blalock-Taussig shunt. The proximal pulmonary artery stump is then connected to the side of the ascending aorta to direct the right ventricular cardiac output into the aorta and the aortic arch enlarged using a patch to relieve any further obstruction (Fig. 8.25).

This operation, undertaken in the newborn period, carries a significant risk even in the best centres and is only the first of three operations that will be required for long-term palliation. It is, therefore, unsurprising that after appropriate counselling many families elect not to proceed down a surgical route and opt for medical palliation understanding that the infant will not survive more than a few days.

Other forms of heart disease where only a single functioning ventricle exists do not require such radical early palliation. The key to presentation and early management is pulmonary blood flow. If flow to the pulmonary circulation is obstructed, the child will usually be duct dependent, present early with cyanosis and require a modified Blalock-Taussig shunt to establish effective blood flow to the lungs. Alternatively if there is no obstruction to pulmonary blood flow, the child will present with tachypnoea and failure to thrive as the PVR drops and flow increases. Such children often benefit from having a restrictive band placed around the pulmonary artery to limit flow, protect the pulmonary

Successful long-term palliation of any single ventricle circulation is critically dependent on ventricular function. Therefore, the surgical strategy employed must ensure that the volume load placed on the ventricle is kept to a minimum. Ultimately the palliation diverts the systemic venous drainage around the heart, allowing it to drain directly to the pulmonary artery and this is usually achieved in two stages given as follows: (1) During the first procedure the superior vena cava is disconnected from the right atrium and reconnected directly to the pulmonary artery, reducing the volume load on the heart but leaving the child still cyanosed. (2) A second and final procedure then redirects the inferior vena caval flow to the lungs, usually by means of an extracardiac conduit. In this way, almost all deoxygenated blood now drains directly to the pulmonary circulation where it is oxygenated before returning to the heart (Fig. 8.25).

The long-term prognosis of children with univentricular forms of heart disease is constantly improving as the techniques for repair continue to develop. Currently life-expectancy without a cardiac transplant is in the third decade, and quality of life is reasonable accepting reduced physical capacity. Clearly, given the resources required to palliate children with univentricular circulations for what appears to be a relatively short period of time, harsh decisions must be made regarding appropriateness of treatment where healthcare funding is limited.

### Vascular Ring

Numerous abnormalities of great artery development can occur, most of which are rare and many insignificant. A vascular ring exists where there is a continuous ring of structures surrounding

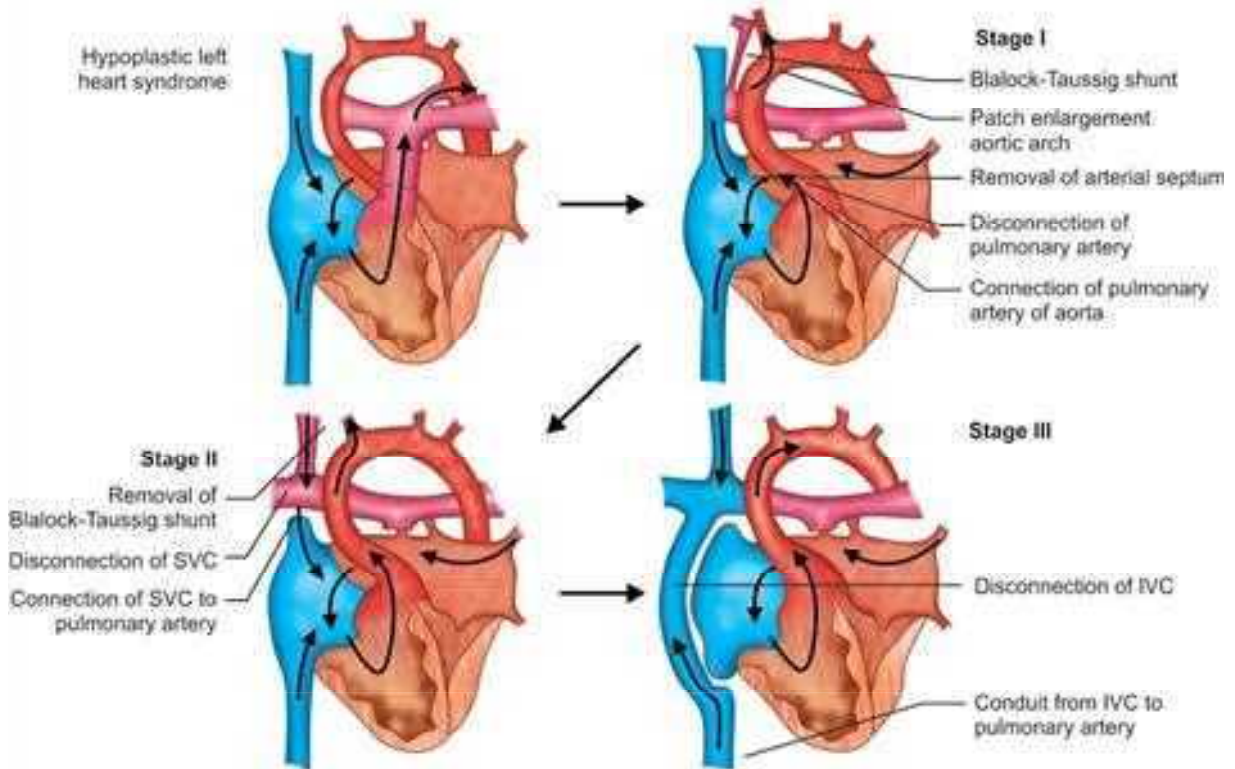


Fig. 8.25: Fontan repair—diagram

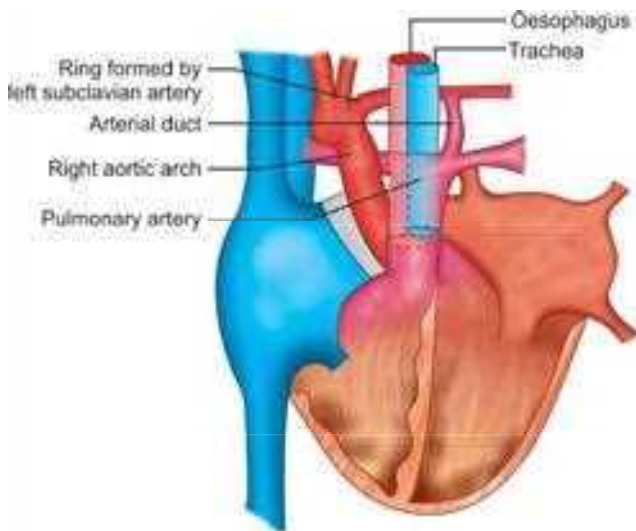


Fig. 8.26: Vascular ring—diagram

result in constriction of the airway and/or oesophagus producing stridor or swallowing difficulties. The most common substrate for this is a right sided aortic arch with a retro-oesophageal left subclavian artery. The ring is completed by a ductal ligament passing from the left subclavian artery to the pulmonary artery

a ring around the trachea and oesophagus. It should be noted that only one of the aortic arches might have flow throughout its course. Other variations in the anatomy of the head and neck vessels rarely cause symptoms.

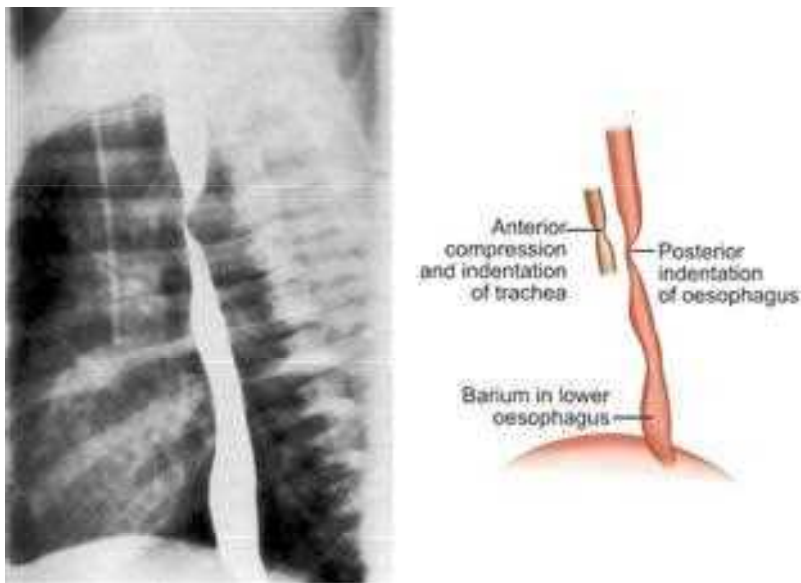
Vascular rings are best diagnosed by barium swallow where the pattern of indentation seen on the posterior aspect of the oesophagus indicates the type of ring (Fig. 8.27). Further evidence can be obtained from bronchoscopy, CT or MRI scans. Echo is less reliable in these situations as at least part of the anatomical substrate often has no lumen or flow.

Treatment is surgical and usually requires simple division of the ligamentous portion of the ring.

## ACQUIRED HEART DISEASE

### Rheumatic Heart Disease

Outside of the North America and the Europe, rheumatic fever is the most common cause of acquired heart disease in childhood. In the acute phase, rheumatic fever is a systemic disorder that causes cardiac morbidity and mortality from acute valve dysfunction and myocardial involvement. Evolution of the valve abnormality to its more chronic form can lead to problems both in late childhood and adult



**Fig. 8.27:** Vascular ring due to double aorta (lateral view barium swallow)

The pathology seen in the heart results from an immune reaction triggered in certain individuals by exposure to Lancefield group A streptococci, usually acquired through an upper respiratory tract infection. Not all group A streptococci cause rheumatic fever and some conflicting evidence suggests that only those belonging to certain M serotypes are responsible for the disease. There also seems to be a familial tendency to develop the disease and the expression of certain HLA groups on a host's B cells may make them more susceptible to rheumatic fever.

Antibodies produced in response to a streptococcal throat infection in a susceptible host react to both the streptococcal M protein and the myosin and laminin filaments within the host's heart. Although antibodies to host myosin cause the myocarditis seen in acute rheumatic fever, it is the reaction to laminin that causes the endocarditis and valve dysfunction so characteristic of acute rheumatic heart disease.

Peak incidence occurs between 10 years and 14 years, but rheumatic fever can be seen in children as young as 3 years and adults as old as 30 years. Carditis is most marked in those affected under 5 years of age.

Acutely the carditis always involves the endocardium, usually the myocardium and occasionally the pericardium. Late sequelae are most commonly related to mitral or aortic valve damage.

Typically the first signs of carditis are a tachycardia and a new murmur. Although the most common murmur seen in acute rheumatic fever is the apical systolic murmur of mitral regurgitation, systolic murmurs are very common

in all children particularly when a tachycardia is present so the appearance of a soft diastolic murmur at the apex is much more suggestive of early carditis. These findings in a child with other manifestations of rheumatic fever should prompt urgent further investigation as unrecognised or untreated carditis can result in arrhythmias and heart failure.

Electrocardiography confirms a sinus tachycardia and often shows lengthening of the PR interval, a characteristic finding in acute rheumatic fever. Echo may show early valve dysfunction, usually regurgitation of the left heart valves, reduced ventricular function or a pericardial effusion. Serology will show evidence of streptococcal infection with a raised antistreptolysin O (ASO) titre greater than 200 IU/ml and often much higher. DNase B is a more sensitive indicator of streptococcal infection but will not start to rise for 1–2 weeks. Other non-specific indicators of a systemic inflammatory process will also be raised including C-reactive protein (CRP) and erythrocyte sedimentation rate (ESR).

## Management

*Management has four distinct aims:*

1. The infection that triggered the inflammatory response must be eradicated to remove the immune stimulus. High-dose intravenous or intramuscular benzyl penicillin should be given for 3 days followed by high-dose oral treatment for a further 10 days. Dose will be dependent on weight.
2. The acute inflammatory response must be suppressed. Bed rest and high-dose aspirin are the mainstays of treatment

Some centres advocate the use of corticosteroids, although there is limited evidence for their use. Acute inflammation can be monitored by measuring the ESR on a daily basis. When this has normalised bed rest can be stopped and moderate exercise positively encouraged. Similarly high-dose aspirin (100 mg/kg per day in four doses) is usually given until at least 2 weeks after the ESR has returned to normal to prevent any rebound inflammation. Whilst using high-dose aspirin, it is sensible to measure serum levels to avoid overdose, maintaining a level of 2 mmol/L (24–30 mg/100 ml).

3. Further streptococcal infections must be prevented. This is adequately achieved using moderate dose oral phenoxymethylpenicillin (250 mg BD) and encouraging compliance. Where compliance is questionable, an alternative would be intramuscular benzathine penicillin. Currently it is recommended that prophylaxis be continued throughout childhood and adolescence up to 21 years of age.
4. Treatment of coexisting cardiac dysfunction is largely supportive with diuretics, digoxin and ACE inhibitor. It is best to avoid surgical intervention in the acute phase, although occasionally this is required. Ultimately chronic valve dysfunction will often require repair or replacement.

## Infective Endocarditis

Whenever bacteria enter the bloodstream of a patient with a structural heart abnormality, there is a possibility of seeding and infection at the site of the lesion. Structural heart lesions cause areas of turbulence and stagnant flow where bacteria can dwell and attach/infect the endocardium. This may be at the site of the lesion such as in the case of a regurgitant mitral valve or where the resultant jet hits the myocardium such as where a VSD jet strikes the opposing right ventricular wall. Bacteria can enter the circulation from a variety of sources, although poor dental hygiene and dental procedures causing *Streptococcus viridans* to enter the bloodstream are perhaps the commonest cause. *Staphylococcus aureus* is another common causative organism which enters through infected skin lesions (e.g. eczema) or during tattoos and piercings. When bacteria infect the endocardium, they can form vegetations (small lumps attached to the endocardium by flexible stalks) or they can invade the myocardium causing abscess formation.

Infective endocarditis (IE) should be suspected in any child with a known structural heart abnormality and an unexplained febrile illness. Classically IE has been described as sub-acute bacterial endocarditis (SBE). This name derives from the pre-antibiotic era where the disease often went undiagnosed for many weeks and the child demonstrated signs of chronic

the finger tips (Osler's nodes), microemboli in the nail beds (splinter haemorrhages), embolic infarctions in the retina (Roth's spots) and anaemia of chronic disease. These findings are now rarely seen, and more commonly the child will present with a fever, tachycardia, changing or new murmur, splenomegaly, splinter haemorrhages and haematuria.

## Investigation

The most important management step in any child with suspected IE is avoidance of antibiotics before blood cultures are taken. At least 3 and preferably 6 sets should be obtained from different venepuncture sites. The microbiologist must be made aware of the suspected diagnosis, as occasionally causative organisms can be very difficult or slow to grow in culture. Blood should also be taken for white cell count, haemoglobin, ESR and CRP. An ECG should be recorded as occasionally IE around the aortic valve can result in heart block and a transthoracic and/or transoesophageal echo should be obtained. It must be emphasised that the absence of vegetations on echo does not exclude endocarditis; however, when seen they confirm the diagnosis.

## Management

Appropriate intravenous broad-spectrum antibiotics can be given after blood cultures have been taken. The agents used can be modified once the target organism and its sensitivities have been identified. Usually parenteral therapy is continued for 6 weeks to ensure eradication of deep-seated infection as judged clinically and by inflammatory markers (CRP and ESR). Surgical excision of vegetations may be required where they pose a serious risk in case of embolism or they are affecting cardiac function. Severe valve dysfunction may also require surgical treatment acutely; however, it is best to "sterilise" the area first using prolonged antibiotic therapy prior to attempting to repair or replace a damaged valve.

## Prophylaxis

Antibiotic prophylaxis is no longer recommended in the United Kingdom. This decision was based on the lack of evidence that the widespread use of antibiotic prophylaxis influenced the development of endocarditis. Different countries vary widely in their recommendations and for many antibiotic prophylaxis remains recommended for any child with an "at risk" cardiac lesion undergoing an invasive dental or surgical procedure likely to cause a significant bacteraemia. All cardiac lesions producing a high velocity jet or turbulent flow are considered at risk of endocarditis. These include aortic stenosis, mitral regurgitation, VSD and PDA. Antibiotic prophylaxis is not required for low velocity lesions such as ASD, mild pulmonary stenosis or 6 months

## Mucocutaneous Lymph Node Syndrome (Kawasaki Syndrome)

Kawasaki syndrome is an idiopathic vasculitis that is often unrecognised but is important due to potential coronary artery involvement. Key features of presentation are persistent fever, a miserable and irritable child, conjunctivitis, lymphadenopathy, swelling of the lips, tongue, hands and feet followed later by desquamation. Coronary artery inflammation results in aneurysm formation with intraluminal thrombus that may occlude the artery causing myocardial infarction. Early recognition of the disease together with prompt administration of immunoglobulin has reduced the incidence and severity of coronary artery involvement and its potentially fatal sequelae. If aneurysms are present, long-term treatment with aspirin should be offered, as the risk of future coronary artery disease is raised.

## Pericarditis

Inflammation of the pericardium with the accumulation of fluid around the heart may occur for a variety of reasons. Pericarditis resulting from viral infections, rheumatic fever, end stage renal failure, malignancy or systemic inflammatory disorders such as juvenile chronic arthritis now constitutes the bulk of cases. Tuberculosis remains an important if less common cause than previously. Similarly, with the widespread use of antibiotics, bacterial pericarditis usually secondary to pneumonia is also now rare.

Clues to the cause of the pericarditis will often be gained from the history. Most children will have some degree of chest pain that will vary in intensity with cause and degree of fluid accumulation (pain often eases as the volume of pericardial fluid increase or when the child leans forward). A fever is often present as is general malaise and lethargy. Symptoms attributable to pericardial fluid accumulation depend on both volume and rate of accumulation. A small amount of fluid entering the pericardium suddenly (e.g. an intravascular cannula perforating the right atrium) will be more disabling than a considerable volume accumulating over time (e.g. tuberculosis). In general, as more fluid accumulates, the child will become increasingly breathless with worsening exercise tolerance. The child will often be more comfortable sitting forward. The cardinal signs are a pericardial friction rub (a scratching sound varying as much with respiration as it does with the cardiac cycle) and muffled heart sounds. With significant pericardial fluid accumulation, signs of tamponade will be present including raised jugular venous pulsation, pulsus paradoxus, tachycardia and hepatomegaly.

ECG will usually show sinus tachycardia, reduced voltage complexes and “saddle-shaped” ST segment elevation. If the effusion is significant, the heart may “swing” with respiration

cycle. Chest X-ray may demonstrate a globular, enlarged cardiac silhouette (Fig. 8.28), and the diagnosis is confirmed by echocardiogram (Fig. 8.29) which will also allow estimation of the size of the collection and show signs of impaired systemic venous return (tamponade). Further investigation centres on establishing the cause, ASO titre, viral titres, CRP and ESR should routinely be sent and a Mantoux test performed. Where pericardiocentesis is indicated examination of the fluid aspirated will usually confirm the diagnosis.

## Management

In the absence of tamponade, most cases of pericarditis will settle with appropriate treatment of the underlying cause and supportive therapy such as bed rest, oxygen and analgesia. Where tamponade is present, the pericardial fluid should be



Fig. 8.28: Chest X-ray—showing pericardial effusion



aspirated and if necessary a drain left *in situ*. Where bacterial or tuberculous pericarditis is present, surgical exploration and lavage may be required to prevent the later development of pericardial constriction.

## Myocarditis

Myocarditis can be caused by viral infection or rarely as part of autoimmune systemic inflammatory disorder. Viral myocarditis results from infection by a wide variety of agents including enteroviruses (particularly Coxsackie B), adenovirus, hepatitis C and HIV. It is unclear why in the majority of children myocarditis is a mild, transient illness, whereas in others it can be rapidly fatal. The degree to which an individual is affected ranges considerably from asymptomatic ECG evidence of myocarditis during viral epidemics to fulminant cardiogenic shock a few days following a usually unremarkable viral illness. Just as viral myocarditis varies widely in its severity so do signs at presentation. Some children demonstrate only a minor tachycardia and summation gallop; whilst others are peripherally shut down (cold, grey and clammy), have low volume pulses, a marked parasternal heave and hepatomegaly.

Patients with myocarditis have a variable outcome. Those with only minor symptoms will usually fully recover, as surprisingly will those with fulminant myocarditis, if they can be supported through the acute illness. Those children who present with moderate to severe impairment of ventricular function have the worst prognosis, with many having long-term ventricular dysfunction.

The ECG usually shows low voltage complexes and may demonstrate ST changes, QT prolongation and possibly ectopic beats or sustained arrhythmias. Chest X-ray usually demonstrates pulmonary plethora; however, the cardiac outline may or may not be enlarged (acutely, although ventricular function is poor, the ventricle may not have had time to dilate). Blood serology for commonly responsible viral agents should be sent and a metabolic screen should be considered in younger children to exclude rare but treatable causes. The gold standard investigation to confirm the myocarditis is myocardial biopsy; however, many centres rely on a clinical diagnosis with or without serological confirmation of viral infection.

## Management

All children with this disease need appropriate treatment for ventricular dysfunction. This will range from diuretics and ACE inhibitors for those with moderate symptoms, up to full intensive care with inotrope support and even mechanical assist devices (if available) for children with fulminant heart failure. Many specific treatments to address the myocarditic process itself have been tried including steroids,

pooled immunoglobulin and other more aggressive forms of immunosuppression. Currently there is no convincing evidence that any are of benefit.

A minority of children may require cardiac transplantation where the heart fails to recover.

## Dilated Cardiomyopathy

Dilated cardiomyopathy is usually idiopathic, although approximately 10% are the end result of viral myocarditis. Other causes are familial inheritance, previous anthracycline chemotherapy, a metabolic derangement such as acylcarnitine deficiency and others are part of a systemic myopathic process such as Duchenne muscular dystrophy or a mitochondrial cytopathy. Whatever the underlying process the left ventricular function is impaired resulting in enlargement that in turn reduces function further. With increasing enlargement the mitral valve annulus dilates causing regurgitation, which further strains the failing left ventricle.

Infants typically present with failure to thrive, poor feeding and tachypnoea. Older children generally complain of a gradual decline in exercise tolerance, often culminating in orthopnoea and resting tachypnoea. Examination will demonstrate the classical triad of tachypnoea, tachycardia and hepatomegaly. In addition, there may be a marked heave, gallop rhythm and the apical systolic murmur of mitral regurgitation.

Diagnosis is confirmed on echo and further investigation revolves around finding a treatable cause. In most cases, none is found and treatment is supportive and symptomatic. Children are usually started on diuretics and digoxin, with the addition of ACE inhibitors and beta blockers such as carvedilol now being commonplace. Some form of anticoagulation is often required to prevent thrombus formation in the ventricular chamber.

It is unusual for there to be a significant improvement in function and most will deteriorate with time. Where possible a cardiac transplant may be the only long-term solution.

## Hypertrophic Cardiomyopathy

Hypertrophic cardiomyopathy is often inherited in an autosomal dominant manner, although sporadic cases do occur. It is also seen in children with Noonan syndrome. Thickening of the left ventricular wall may be concentric or predominantly within the septum (asymmetrical septal hypertrophy). These changes result in impaired filling of the left ventricle and where asymmetrical hypertrophy is present sub-aortic obstruction develops. Unfortunately all forms are at risk of ventricular arrhythmias and sudden death particularly on exercise.

Many children are asymptomatic at presentation and discovered during screening where another family member



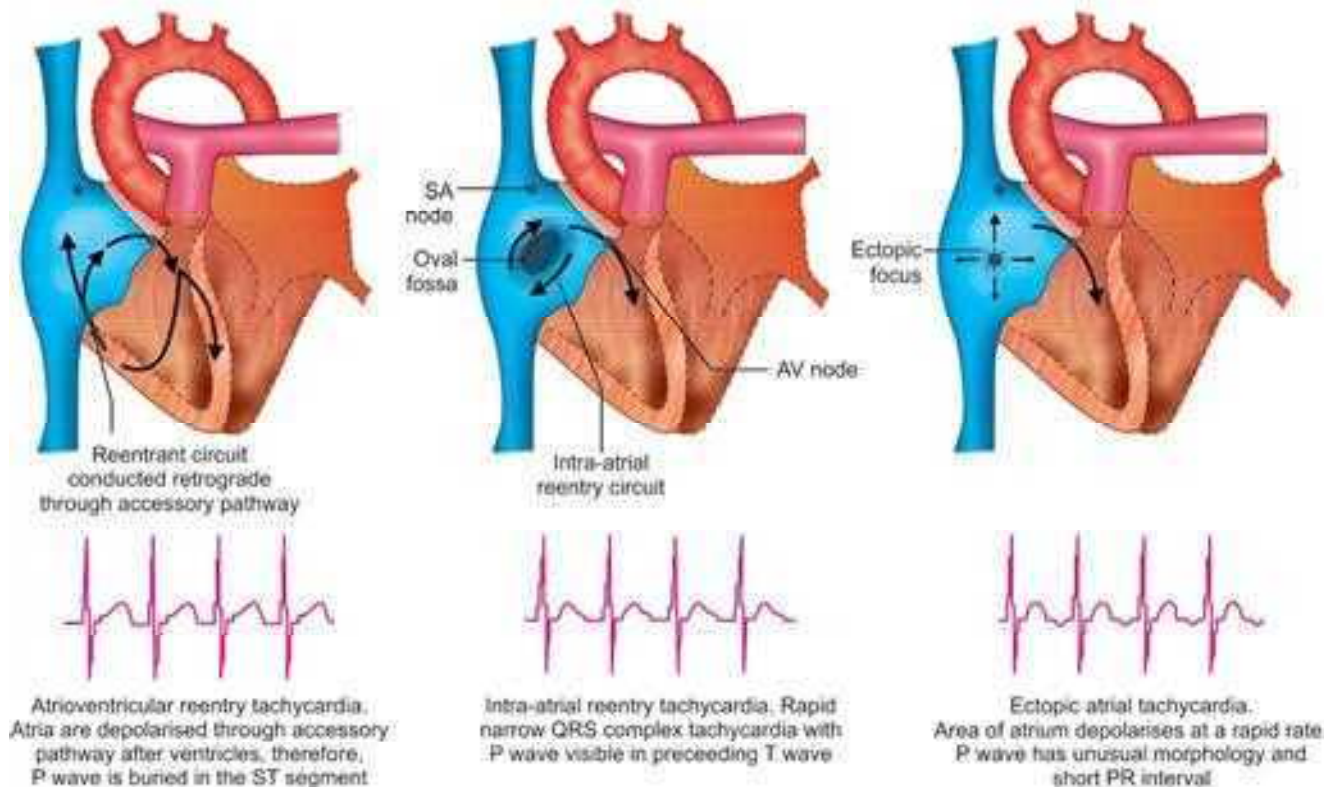


Fig. 8.30: Supraventricular tachycardia—mechanism diagram

is affected or where a murmur has been detected and referred for investigation. Other children may present with exertional dyspnoea, chest pain, dizziness or syncope.

Diagnosis is by echocardiogram. Whilst the ECG may show changes of hypertrophy and strain, a normal test does not exclude the diagnosis. When a diagnosis has been made, screening should be offered to first-degree relatives.

If significant hypertrophy is present intense, exercise should be avoided and beta blockers may be used for symptom control. Although many treatments including surgical resection of the muscle have been tried the only measure shown to be of benefit in these patients is an implantable defibrillator.

## HEART RHYTHM ABNORMALITIES

### Normal

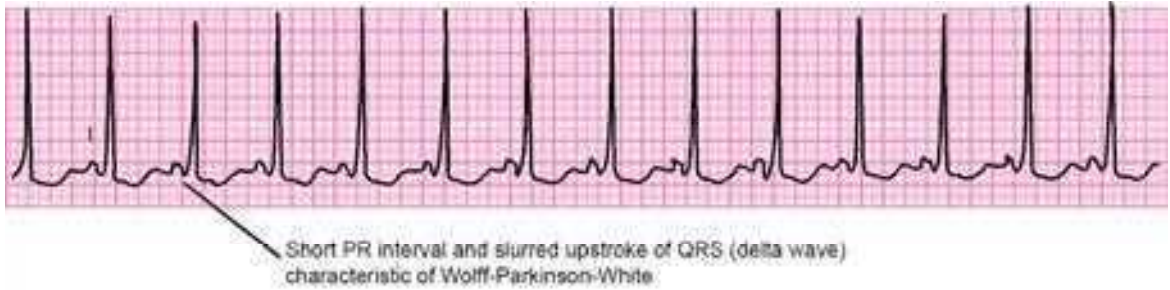
Normal heart rate, like blood pressure, varies with age. A neonate should have a rate of 110–150 beats per minute (bpm), infants 85–125 bpm, 3–5 years 75–115 bpm and over 6 years 60–100 bpm. The heart rate in infants may rise as high as 220 bpm when febrile. Sinus arrhythmia is common in children and can produce a marked drop in heart rate during expiration. Extra beats are also common

in childhood. Atrial or junctional ectopic beats can be recognised as narrow complex and may have a preceding abnormal P wave. They are benign and require no further investigation. Ventricular ectopics are broad complex and also occur in healthy children; however, occasionally they can indicate underlying myocardial disease, electrolyte derangement or drug ingestion. When they can be shown to disappear on exercise they require no further investigation. Three types of rhythm abnormality deserve further attention; (1) supraventricular tachycardia (SVT), (2) ventricular tachycardia (VT) including torsades de pointes and (3) complete heart block (CHB).

### Supraventricular Tachycardia

Supraventricular tachycardia in childhood is a narrow complex tachycardia, with rates usually of between 200 and 300. There are many different underlying mechanisms but most fall into two groups.

1. *Reentry arrhythmias*: These arrhythmias are by far the commonest and are caused by an electrical circuit developing either through the AV node (e.g. Wolff-Parkinson-White) or within the atria (e.g. atrial flutter) (Fig. 8.30). The electrical impulse passes around the loop, repeatedly ending off an action potential to start



**Fig. 8.31:** ECG showing Wolff-Parkinson-White syndrome

and ventricles with each circuit. In most childhood, SVT including Wolff-Parkinson-White syndrome the reentry circuit involves the AV node and an accessory pathway (extra piece of conduction tissue connecting the atria to ventricles). These arrhythmias tend to be paroxysmal in nature and usually have rate of 200–250 bpm. In atrial flutter, the circuit occurs within the atria often around the foramen ovale and the atrial rate is faster ranging from 500 bpm in the newborn to 300 bpm in adolescents (usually only alternate beats are conducted to the ventricles).

2. *Automatic tachycardias:* These arrhythmias are also known as ectopic tachycardias. They arise from increased automaticity of a group of cells within the myocardium (Fig. 8.30). Essentially the abnormal focus depolarises at a faster rate than the sinus node, thus taking over the role of pacemaker. If the rate of depolarisation exceeds normal for the child concerned, it is designated a tachycardia. These forms of tachycardia tend to be incessant and have lower rates of 160–220 bpm.

### Presentation

Infants are unable to communicate symptoms of palpitation. Due to this, SVT lasting less than 24 hours may remain undiagnosed. When prolonged, however, symptoms of heart failure (poor feeding, sweating and poor colour) develop, raising awareness of the problem. Incessant, automatic tachycardias tend to have slower rates and cause less haemodynamic compromise. They usually take longer to present and often do so with a form of dilated cardiomyopathy. In contrast to infants, older children will complain of odd feelings, thumping or fluttering within the chest after relatively short episodes. More rapid forms can be associated with chest pain, breathlessness and dizziness, particularly when prolonged.

### Investigation

The paroxysmal nature of many tachycardias makes accurate diagnosis difficult. A baseline ECG may reveal the short

(Fig. 8.31), or may show a prolonged QT interval suggesting a VT is responsible for the symptoms (below). Ideally a 12-lead ECG should be recorded during the tachycardia that will provide the optimum information for an accurate diagnosis. Where episodes are infrequent obtaining a 12-lead ECG may prove impossible in which case ambulatory recordings can be obtained using one of the many systems now available. An echocardiogram is also performed to exclude associated structural heart disease.

### Management

Acutely, re-entry forms of tachycardia may respond to vagal manoeuvres. In infants, immersing the face in ice cold water for 5 seconds may be tried. Older children can be taught to perform a Valsalva's manoeuvre. If these measures fail, intravenous adenosine is a very effective alternative. Because it has a very short half-life in the circulation it should be injected through a large cannula in a proximal vein with a rapid bolus and flush. By convention a small dose is used initially (0.05 mg/kg) which is increased in steps to 0.25 mg/kg (max 12 mg). If this fails, it is likely the arrhythmia is automatic in nature. Acutely automatic tachycardias are harder to control and often require preloading with an antiarrhythmic agent such as amiodarone prior to synchronised electrical cardioversion (0.5–1 J/kg).

Chronically many children with infrequent short episodes of SVT require no treatment and adequate explanation is sufficient to reassure them and their parents. Where episodes are infrequent but of long duration, patients can be offered a "pill in pocket" form of treatment. This involves the child carrying a supply of verapamil or a beta blocker to take only when an attack starts. The medication is designed to terminate the attack rather than prevent it. Where episodes are frequent many families prefer preventative treatment, usually with digoxin, beta blockers or verapamil. If the baseline ECG demonstrates Wolff-Parkinson-White syndrome, digoxin is considered contraindicated at most ages and should be avoided (it can

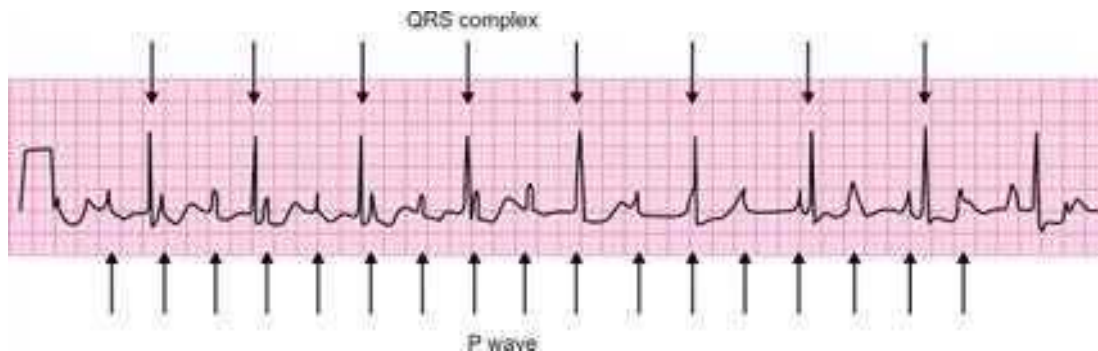


Fig. 8.32: ECG—complete heart block

pathway allowing rapid ventricular depolarisation and raising the chance of VT or fibrillation). By convention the presence of SVT in an older patient with documented Wolff-Parkinson-White syndrome is considered to be an indication for transcatheter radiofrequency ablation. If other forms of SVT persist despite medical treatment, radiofrequency ablation of the accessory pathway can be offered to abolish the arrhythmia.

### Ventricular Tachycardia/Fibrillation

Ventricular arrhythmias are very rare in childhood even after congenital heart surgery. There are, however, an expanding group of inherited conditions known to predispose individual patient to ventricular tachycardiac and sudden death. These comprise the long QT syndromes, Brugada syndrome and arrhythmogenic right ventricular dysplasia. The inheritance of these conditions is complex and sporadic cases occur. Most affected individuals have an abnormal resting 12-lead ECG and many have a prolonged QT interval.

Once an individual patient has been diagnosed with one of these disorders close family members should be offered screening either by 12-lead ECG or where available genetic analysis for the culprit gene.

Where an effected individual is identified treatment with a beta blocker or an implantable defibrillator is usually indicated.

### Complete Heart Block

In complete heart block (CHB), the electrical activity of the atria is isolated from that of the ventricles. The atria beat at one rate whilst the ventricular rate (effective heart rate) is slower (Fig. 8.32). This is a rare condition. The congenital form is usually seen in newborns where the mother has circulating anti-La and anti-Ro antibodies and may have systemic lupus erythematosus or a related connective tissue disorder. These antibodies cross the placenta and damage the heart particularly

heart block can also be seen rare forms of congenital heart disease such as congenitally corrected TGA and in atrial isomerism. The most common cause of acquired heart block is iatrogenic and is a complication of open heart surgery when the conduction system is damaged. Often this is a transient problem lasting no more than a few weeks; however, in some children it can persist requiring a pacemaker. Bacterial endocarditis particularly around the aortic valve can destroy the junctional tissue and also cause heart block.

In the congenital form, if an infant's heart rate is greater than 55 bpm and there is no heart failure, no treatment is indicated and the outlook is reasonable. Where the heart rate is slower or heart failure coexists then a pacemaker may be required. In acquired forms, where the block is permanent a pacemaker is always indicated.

## CASE STUDIES

### 1. Infant VSD

A 4-week-old child presents with failure to complete feeds, poor weight gain and sweating. On examination a cachectic child is noted with a respiratory rate of 60, moderate sub-costal in drawing, normal pulses, an enlarged liver, a marked sub-xiphoid heave and loud second heart sound. There is a 2/6 systolic murmur audible at the upper left sternal edge and radiating to the lower left sternal edge.

*Name three possible diagnoses.*

VSD, AVSD and truncus arteriosus. Not PDA as murmur wrong, note loud PSM not a constant finding in large VSDs.

*What investigations are required?*

ECG, Echo.

*What medical treatment measures would you take?*

Introduce high calorie nasogastric feeds, start a loop diuretic such as furosemide together with spironolactone, refer for surgical correction before 6 months of age (risk of irreversible

## 2. Cyanosed Newborn

A 3-day-old child is found to be cyanosed on pre-discharge check. The child is otherwise well, with no dyspnoea and only a mild tachycardia of 160 bpm. On examination there are normal femoral pulses, no hepatomegaly, no heave, loud second heart sound and no murmurs.

*Name three possible diagnoses.*

TGA, PAT and tricuspid atresia. Not tetralogy as a significant murmur would be present if cyanosed and not atretic.

### Ventricular Septal Defect

- A VSD murmur may not be heard at birth
- Loudness of the murmur does not correspond to the size of the defect
- Small VSD often need no treatment
- Large VSDs are the most common cause of heart failure in infants
- Large VSD should be repaired before 6 months to protect pulmonary arterioles
- VSDs place an increased volume load on the left heart.

### Heart Failure in Infants

- Nasogastric feeding removes work of feeding and maximises caloric intake
- Diuretics, digoxin and ACE inhibitor constitute medical treatment
- Aim to identify and treat cause
- Oxygen therapy may worsen heart failure.

### Atrial Septal Defect

- ASD commonly has no symptoms
- Signs may be minimal in childhood
- ASD can cause fixed, wide splitting of the second heart sound
- ASD places an increased volume load on the right heart
- ASD does not require antibiotic prophylaxis.

### Patent Ductus Arteriosus

- PDA produces a continuous “machinery” murmur
- PDA is common in prematurity where they can cause heart failure
- Indomethacin can be used to close PDA in prematurity
- Most PDA in childhood can be closed by a transcatheter technique

### Atrioventricular Septal Defect

- Complete AVSD usually present as heart failure in infancy

- AVSD is common in Down’s syndrome
- AVSD causes left (superior) axis on the ECG
- The atrioventricular valves are often regurgitant
- Complete AVSD requires repair within 6 months.

### Coarctation of the Aorta

- Infants with coarctation present with heart failure at 3–10 days when the arterial duct closes
- Always examine the femoral pulses during routine clinical examination
- Older children with coarctation present with hypertension or a murmur at the back.

### Aortic Stenosis

- Clinical assessment of the severity of aortic stenosis can be difficult
- Aortic stenosis causes left ventricular hypertrophy
- Neonates with severe aortic stenosis depend on the arterial duct for the systemic circulation
- Older children with severe aortic stenosis are at risk of syncope and sudden death
- Aortic stenosis can be treated by balloon valvuloplasty or surgery.

### Pulmonary Stenosis

- Pulmonary stenosis causes right ventricular hypertrophy
- Neonates with severe pulmonary stenosis depend on the arterial duct for the pulmonary circulation
- Moderate pulmonary stenosis in infancy can improve with growth
- The treatment of choice for pulmonary stenosis is balloon valvuloplasty.

### Tetralogy of Fallot

- Suspect tetralogy in any infant with a harsh systolic murmur and cyanosis
- The key lesions in tetralogy are the degree of sub-pulmonary stenosis and the VSD
- Cyanosis worsens with growth
- Hypercyanotic spells are a feature of severe sub-pulmonary obstruction
- A Blalock-Taussig shunt can be used to palliate children with tetralogy.

### Transposition of the Great Arteries

- Suspect transposition in an asymptomatic cyanosed neonate with no murmur
- Transposition is a “duct-dependent” lesion and should be treated with prostaglandin E

- Prostaglandin E can cause apnoea
- Most children with transposition require an atrial septostomy.

### Tricuspid Atresia

- Suspect tricuspid atresia in any cyanotic infant with left axis deviation on the ECG
- Cyanosis is usually progressive, requiring early palliation
- Ultimately children with tricuspid atresia will require a Fontan-type repair.

### Pulmonary Atresia

- Infants with PA are dependent on arterial duct flow
- Where the ventricular septum is intact the right ventricle is hypoplastic
- Management is often complicated requiring several procedures

### Univentricular Heart

- All infants with a single functional ventricle require regulation of the pulmonary blood flow
- Ultimately a child with a single ventricle will require a Fontan-type repair
- A Fontan-type repair directs the systemic venous drainage directly to the pulmonary artery, bypassing the heart
- In the long-term single ventricles fail.

### Rheumatic Fever

- With widespread use of antibiotics, the initial presentation of rheumatic fever can be atypical
- ASO and anti-DNase will always rise
- Eradication of the *Streptococcus* with penicillin is a crucial first step in management
- Following recovery long-term prophylaxis should be given to prevent further attacks.

### Infective Endocarditis

- Consider endocarditis in any child with a heart lesion and unexplained fever
- Avoid antibiotics until several sets of blood cultures have been taken
- Echocardiography cannot exclude the diagnosis
- Prolonged parenteral antibiotic therapy is mandatory.

### Kawasaki Disease

- Coronary artery involvement is common in Kawasaki disease if untreated

- Early immunoglobulin therapy prevents coronary aneurysm formation
- Aneurysm can give rise to coronary ischaemia and infarction both acutely and later in life.

### Pericarditis

- Consider pericarditis in a child with chest pain and a large heart on X-ray
- A pericardial rub may be absent where significant fluid has accumulated
- Tamponade depends on how quickly fluid accumulates, not how much.

### Myocarditis

- Myocarditis is usually caused by a viral infection, most commonly Coxsackie B
- Although many children are only mildly affected, some develop fulminant myocardial failure
- Even in severe myocardial failure, a good recovery is possible
- Some children with moderate myocarditis will develop a dilated cardiomyopathy.

### Hypertrophic Cardiomyopathy

- Most children have no symptoms when diagnosed
- Chest pain, dizziness or syncope on exercise are worrying symptoms
- Close family members should be screened
- Intense exercise should be avoided.

### Supraventricular Tachycardia

- In SVT, the heart rate is usually over 200 bpm and difficult to count on examination
- Infants with SVT may not present until myocardial function is affected by prolonged tachycardia
- Re-entry forms of SVT can be terminated by vagal manoeuvres and adenosine
- Automatic tachycardias can be resistant to treatment and cause cardiomyopathy
- Children with Wolff-Parkinson-White syndrome should not receive digoxin
- Most SVT carries a good prognosis.

### Heart Block

- Congenital heart block is associated with maternal anti-Ro and anti-La antibodies
- A pacemaker is indicated, if the mean heart rate is less than 55 or there is heart failure.

# Care of the Paediatric Surgical Patient

## BASIC PAEDIATRIC SURGERY

### INTRODUCTION

This preliminary chapter on paediatric surgery provides a bird's eye view about the paediatric surgical diseases and about the bedside history taking skills required for such patients. The essential preoperative and postoperative care required for such patients is described. The later part of the chapter deals with fluid and electrolyte management that is the crux for successful management of the the surgical children. It is a must for every medical practitioner to know about paediatric surgical illness for timely diagnosis, appropriate management, safe transportation and referral to higher centres for complicated illnesses needing tertiary level care. The primary physician caring for children should be aware of the technique and art of paediatric basic life support and paediatric advanced life support. The aim of these text articles is to provide basic idea of paediatric surgical illnesses, their manifestation and diagnosis, and to emphasize on the pre-treatment emergency care and timely referral for saving life of children.

### HISTORY TAKING OF PAEDIATRIC SURGICAL PATIENTS

The advancements in medical technology cannot replace the information acquired with a proper history taking and bedside clinical examination. They lead the treating doctor to the illness concerned and reduce the gap between time of presentation and finalizing the diagnosis by streamlining the investigation and excluding the conditions having similar manifestation. It also avoids unnecessary investigation and helps the proper and economic usage of available manpower and health resources thus over all reducing the national health care cost without compromising the quality of care given. As a student it is mandatory to learn the art of methodical history

taking and examination, which plays a pivotal role in further dealing with patients and improving the future career.

A child manifesting with a disease may be having other occult problem involving other system of the body which all can be explained by a single cause called as the sequence for example Pierre Robin sequence is a condition in which there is cleft palate, micrognathia and glossoptosis. The presence of these entire three problems is due to a small size mandible, which causes the tongue to fall back and prevent closure of the two halves of secondary palate during the developmental period. If all the group of disorders cannot be explained by single aetiology then it is called as syndrome. Some innocuous superficial manifestation may really be representative of severe dreadful underlying disease in paediatric age group. For example, white-eye in an adult is due to senile cataract whereas in a child it may be due to retinoblastoma.

History taking should be methodical to prevent losing important history. After obtaining the history it should be recorded in the record sheet of the patients, which is important for others to understand and for doctors' future review. Throughout the history taking the parents and child should be encouraged. The history is obtained and recorded in the following headings.

#### History of Present Illness

In this what problem made the parents to bring the child to hospital is obtained and recorded in non-medical terms in descending order of severity and chronological order. The relevant leading questions can be asked to parents to rule out the conditions having the same presentation. Enquiry should also be made to know the possible aetiology and also to know how much the parents are aware of their kid's problem. From this detailed history itself doctors can come to conclusion about the possible system affected and the possible differential diagnosis.

## History of Past Illness

By knowing about the past illness, it may be possible to correlate the present problem if related one. Enquiry about any complications during the previous anaesthesia and surgery provides an opportunity to remain alert in the future. Any associated medical illness present should also be taken care during the surgical treatment.

## Family History

Since certain illnesses run in families, by enquiring about family members having similar illness we can arrive at diagnosis, the risk of other family members being affected with similar illness and need for screening asymptomatic cases can be ascertained. For example, a child presenting with bleeding per rectum with multiple colorectal polyps may be suffering from familial adenomatous polyposis.

## Antenatal History

History of severe medical illness, febrile conditions, abortion, anti-teratogenic exposure in the form of radiation, drugs, etc. is enquired. Any problem to the mother like polyhydramnios (in congenital gut obstruction) oligohydramnios (in posterior urethral valve) gives suggestion about any congenital illness, antenatal ultrasonogram which is an integral part of antenatal screening detects fetal anomalies and helps to plan about, MTP, planning time and mode of delivery and early postnatal care for fruitful outcome.

## Birth History

The time of delivery (term or preterm), place of delivery (hospital or home delivered) and mode of delivery (vaginal or cesarean) are to be enquired which all carry importance during management.

## Developmental History

About the milestones achieved and mental age and chronological age are ascertained by examining the anthropometric chart maintained by the paediatrician.

## Immunisation History

To know about the immunisation status the vaccines administered with reference to national immunisation schedule is enquired and entered in the case record.

## Nutritional History

About the duration of breastfeeding, weaning administered, amount of food material consumption now are recorded.

## CLINICAL EXAMINATION

Preparing the child for the physical examination helps to reduce anxiety and minimizes trauma. It also enhances the doctor's ability to perform a comprehensive examination. Make an effort to increase the child/adolescent's sense of control and suggest relevant coping strategies. In addition, throughout the examination, reassure the child and encourage him by sweet words or morale. Assess the child level of fearfulness before the examination. This information will be helpful in determining appropriate preparation strategies.

Bedside manners which have to be followed during history taking and examination:

- Before entering knock at the door of the suite in which patient is staying, always introduce yourself to parents and the child, have a smiling face and never stare at the child.
- Use simple language when communicating with the parents, pay attention to their words, and nod head for their response, maintain eye-to-eye contact.
- Wear light colour dress and some suggest even avoiding large white coat, which may panic the child.
- Be aware of fears specific to age or developmental level and be familiar with some management techniques.
- Attach toys to the stethoscope; the outpatient cubicle should be clean and free of large medical appliance, cast, specimen, etc. that may be annoying to the child.
- Examine in good natural lighted room, get the permission of the parents before examining the child, and warm your hands before touching the child in cold countries, best time to examine a child is when the baby is feeding or sleeping which should be made use of whenever feasible.
- Proper positioning is essential for painless examination and for detecting clinical signs. Examine always gently without jerky forceful manipulation.
- Examine in single attempt thoroughly keeping all the differential diagnosis in mind.
- Explain the examination in child-friendly language that uses developmentally appropriate words.
- Remember that children often interpret statements very literally.
- Provide toys, music, and pacifying speech during examination.
- Avoid the use of medical restraints or force of any kind during the examination. Allow children and adolescents to choose whether they would like a parent or care giver present during the examination. Examine the painless area first, encourage the child during examination and build their self-confidence during history taking and examination, never do painful procedure in front of other child, keep parents throughout the examination bedside, keep the mental agony of the family due to sick child in mind.

- It is unusual to use sedation or anaesthesia for the examination. The use of medication should be restricted to situations where suspected major injuries require assessment or surgical repair. If sedation or anaesthesia must be used, carefully explain the procedures to the child/adolescent and parent or care giver and obtain consent. Express empathy and give assurance to the parents, based on scientific evidence.
- The typical head to feet examination system may not be feasible in children and hence modification of the examination system may be needed in some uncooperative children. Examine the relevant things first and avoid causing pain during examination. Apart from examination of the major systems like respiratory system, cardiovascular system, central nervous system and abdomen, detailed examination about the nutrition and development by anthropometry is also needed.

## PRE-AND POSTOPERATIVE CARE

Preoperative assessment is an important evaluation that provides wide information about the child's disease status, family circumstances and making a good rapport for future follow-up. It also helps the child and parents to get accustomed to the new surgical environment. The pre anaesthetic evaluation includes examination of major organ systems and emphasis on any recent illness like respiratory infection, which is important from anaesthetic point of view. This is evidenced by the observation that operating on a child with acute recent respiratory infection will increase the adverse events by seven folds during induction of anaesthesia and extubation.

### Associated Medical Problems

Children undergoing surgical procedures can have other associated medical illnesses, which need special consideration while undertaking surgery especially in high-risk patients. Patients may be taking medications for the medical illness. There are some drugs, which have to be continued till the morning of the day of surgery for example steroids, thyroxin, antiepileptics, etc. There are some drugs, which can interact with anaesthetic agents and may need to be changed to safer drugs or discontinued if there is no contraindication for stopping the drug. For example tricyclic anti-depressants are ideally to be stopped at least two weeks before surgery and aspirin has to be stopped 6 weeks before. Apart from the medications, there is also concern in preparing those patients for uneventful good outcome. In patients with congenital heart disease or valvular heart disease prophylactic antibiotics with ampicillin and gentamycin in general surgical procedure and

added metronidazole for colorectal surgery are mandatory to prevent dreaded sub-acute infective endocarditis. Patients with major organ disease are not candidates for out patient's surgery because it is to prevent an early intervention of postoperative calamities

There is also major issue about the preoperative routine laboratory investigations in paediatric age group. The American Society of Anaesthesiologists stated that routine preoperative investigation is not needed in paediatric age group. Decisions regarding the need for routine preoperative investigation should be based on the individual patients and the proposed surgical procedure. This avoids, mechanical trauma to the child by difficult venipuncture, unnecessary investigation causing manpower and economic loss.

### Pre-anaesthetic Medication

Usage of certain medications before the induction and preceding to surgery makes anaesthesia smooth and avoids anxiety and preoperative complications like aspiration pneumonitis. Anxiolytics like diazepam, midazolam, ranitidine, analgesics like fentanyl or pethidine and atropine to reduce secretions and prevent bradycardia is suggested in pre-anaesthetic medications. However, in an emergency situation the patient is resuscitated and taken for surgery.

### Preoperative Antibiotics

The policy of administration of pre-induction antibiotics reduces the infection rate to almost nil and avoids unnecessary prolonged administration of antibiotics in a clean surgery. In a clean case only three doses of antibiotics are recommended. In cases with frank sepsis it is based on severity and culture and sensitivity. On special occasions a longer course of antibiotics may be needed, for example, in urological surgeries. Patients with cardiac problems and metallic implants (in joints and valves) need prophylactic antibiotics. In children there is no need for prophylactic administration of heparin to prevent deep vein thrombosis, as it is uncommon except in cases with congenital predisposition like protein S or protein C deficiency.

### Transportation of Patients

In case of newborns proper maintenance of temperature and safe transport in transport incubator to operation suite is mandatory to prevent hypothermia and cardio-respiratory depression. In patients with central venous line or intra-arterial line continuous flushing with heparinised saline is essential to prevent blockage of line. In very sick patients continuous monitoring with pulse oxymeter, uninterrupted respiratory support with battery back-up, emergency resuscitation drugs should accompany.



## Securing Intravenous Access

Safe secure intravenous line is essential component in the surgical management of patients. It is mandatory to learn the technique of safe insertion and safeguarding the line by proper immobilization with splints and dressings because finding and getting intravenous access may be difficult. Difficult cases may need open venesection or central venous access. Local anaesthetic EMLA cream may be applied half to one hour before the intravenous access for painless insertion of intravenous line. In very uncooperative patients inhalation induction done with halothane or sevoflurane and then intravenous access and intubations can be done.

## Postoperative Analgesia

Non-steroidal anti-inflammatory drugs (NSAIDs) along with local anaesthesia are the mainstay of postoperative pain relief in paediatric day case surgery. They have several advantages over opioid analgesics including a lack of respiratory depression and sedation. They do not cause nausea or vomiting. NSAIDs have been found to be very effective analgesics in older children. However, use of these agents is not recommended below one year of age due to the possibility of immature renal function and hepatic metabolism. Paracetamol (acetaminophen) Diclofenac, ibuprofen and Ketorolac are the most commonly used agents. Administration of these agents before surgery as a pre-medication provides optimal analgesia due to their anti-inflammatory activity.

Opioids are not ideal for paediatric day case surgery as they may produce respiratory depression, excessive sedation and postoperative nausea and vomiting. With some procedures however, opioids are required during and after surgery to control pain. Shorter acting opioids are ideal—Fentanyl (1–2 µg/kg) is commonly used. Longer acting opioids (morphine/pethidine) may be required if postoperative pain is unexpectedly severe. Although the procedure may have been planned on a day case basis, unexpected hospital admission may be required for control of severe pain.

## Out-patient Surgery

In patients with minor paediatric surgical illness, 70% of cases can be managed as out-patient ambulatory cases. In selecting cases for out-patient management needs, consideration about the disease concerned because major procedure involving opening of cavities cannot be discharged after the procedure and associated severe medical illness, preterm, previous anaesthetic complications, no access for emergency problem are considered contraindication for out-patient office procedure. From the time of invention of laparoscopy, the chances of early discharge are possible with less postoperative pain.

## Planning Discharge and Follow-up

Patient's condition should be assessed thoroughly before thinking of discharge. Parents should be instructed as early as possible and provide time for them to prepare for situation. Assistance should be provided in arranging for transport, issue of medications for further use. The warning signs of any complications should be mentioned to parents for early review to the emergency. The family physician or periphery district hospital of the locality should be communicated about the patient about the type of procedure done and follow-up instructions and any warning signs for early referral.

Patient's detailed contact address, phone number; electronic mail address is recorded properly in the discharge registry for future contact and follow-up. The drugs to be administered, instruction to be followed and frequency of follow-up are to be provided before discharged. The advice in the local language or the language which parents can understand easily helps in gaining good rapport and compliance. Contact number of the hospital and the consultant or nearby family physician should be given to patients for any emergency contact.

## FLUID AND ELECTROLYTE MANAGEMENT

### Significance of Fluid Management in Children

From the time of origin of foetus there are dynamic changes in the fluid and electrolytes. Soon after delivery there is a change in the amount of fluid in the intracellular fluid into the extracellular. Fluid management in the preoperative period is divided into replacing the preoperative fluid deficit, ongoing maintenance requirements and replacement of intraoperative losses, continuing into the postoperative period. For elective patients the deficit before surgery should be minimal because oral fluids may be safely given until 2 hours before surgery. For the emergency patient, the degree of dehydration must be assessed and corrected, along with any electrolyte disturbance. During surgery the doctors need to give maintenance fluid to replace insensible and obligatory losses, along with replacing blood loss and loss of fluid into the third space due to the trauma of surgery for maintenance of fluid, the doctors need to use an appropriate dextrose and electrolyte content to maintain homeostasis. The commonest electrolyte disturbance in the postoperative period is hyponatraemia, usually as a result of inappropriate anti-diuretic hormone secretion, often in combination with the use of hypotonic solutions with a low sodium concentration.

Children have more fluid per meter square body surface area than adults. In adults 60% of the body weight is due to water whereas in a newborn the water constitutes 80% of the total body weight. In adults, 20% of the water is extracellular and 40% as intracellular, whereas in newborns, it is 45%

extracellular and 35% intracellular. The significance of this difference is that in cases of dehydration due to any reason because of the large extracellular fluid the loss may not be obvious till a late stage by which time the child would have lost significant volume.

The amount of fluid loss through skin is also more and hence the overall fluid requirement per square meter of body surface area is also more. In newborns, the kidney is not fully mature to handle fluid load and there is loss of fluid and sodium. Therefore pathological changes can lead to changes that lead to disturbance of homeostasis leading to drastic irreversible changes. A healthy full-term newborn loses about 10% of its total body water in its first one week of life because pre-term infants have an increased total body water content and extracellular compartment. They lose on an average of about 15% of their weight after birth in the first week of life. There is a pre-diuretic phase in the first day of life, followed by diuretic phase in the second to third day and then the post-diuretic phase from the fourth day onwards.

There are also changes in the intracellular solute. Potassium is the major intracellular compartment cation and sodium is the major extracellular cation. Changes in the osmolality of extracellular compartment are reflected as net movement of water in and out of the cells.

### Regulation of Solute and Fluid

Starling's law regulates the exchange of fluids between the intravascular and extravascular compartment. Under physiological conditions the balance between hydrostatic force and oncotic pressure determines the amount of fluid moving across the capillary membrane. Under various pathological conditions this balance can be disturbed leading to expansion of interstitial compartment at the expense of the circulating intravascular compartment. In health, a balance is struck between intracellular and extracellular osmotic forces and interstitial and intravascular oncotic forces, which in turn, govern fluid distribution between the intracellular, extracellular and interstitial fluid compartments. The use of hypo- and hypertonic electrolyte solutions has major effects on brain cells, which can be detrimental or beneficial.

The sodium and potassium maintenance is important for critical cell function. They are maintained by kidney, blood and bone buffers. Hormones like steroids, ADH (ant-diuretic factor), ANP (atrial natriuretic factor) and aldosterone play dominant role in sodium maintenance. Reduction of serum level of sodium (hyponatraemia) is mostly due to loss of gastrointestinal fluid, diuretics, burns, pancreatitis, adrenal insufficiency, etc. It manifests with lethargy, perioral numbness and convulsions. The correction is to be done slowly otherwise demyelination of nervous system occurs. The total deficit is calculated by using the formula-sodium deficit in mEq/L is  $0.6 \times \text{weight in kilogram} \times (135 -$

serum sodium). Potassium the major intracellular cation, homeostasis is maintained both by renal and extrarenal mechanisms. In kidney the increase in serum potassium level stimulates aldosterone, which in turn, acts upon distal convoluted tubule to reabsorb sodium in exchange for potassium thereby excrete potassium to maintain electroneutrality. Extrarenal homeostasis is also maintained by aldosterone by causing potassium loss in the colon, saliva and sweat. Following three factors enhance the movement of potassium into the cell. Alkalosis causes an efflux of  $H^+$  from the cells and in exchange  $K^+$  moves intracellularly. Insulin increases  $K^+$  uptake by the cells by directly stimulating Na-ATPase activity independent of cyclic AMP. Beta agonists act by stimulating cyclic AMP via adenylate cyclase, which in turn, activates Na- $K^+$  ATPase pump.

Calcium homeostasis is maintained mainly by the parathormone secreted by the parathyroid gland and calcitonin secreted mainly by parafollicular C cells of thyroid and some amount by parathyroid gland.

The body water deficit can be estimated on the basis of the degree of dehydration. The water deficit is calculated from the degree of dehydration as 10% of intravascular fluid is lost in mild dehydration, 25% lost in moderate dehydration and up to 50% is lost in severe dehydration.

### Clinical Signs of Dehydration

<b>CVS</b>	Moderate: Tachycardia collapsed veins, collapsed pulse Severe: Decreased BP, cold extremity, distant heart sounds
<b>GIT</b>	Moderate: Decreased food consumption, Severe: Nausea, vomiting, silent ileus, and distention
<b>Tissues</b>	Moderate: Wrinkled tongue with longitudinal wrinkling Severe: Atonic muscles, sunken eyes
<b>CNS</b>	Moderate: Excess sleepiness, apathy, and slow response Severe: Decreased tendon reflexes.
<b>Metabolism</b>	Moderate: Mild decrease in temperature (97–96° F) Severe: Marked decrease in temperature (95–98° F)

### Type and Rate of Administration of Intravenous Fluid

The type of fluid, rate of administration is decided by the cause and degree of dehydration. Fluid of choice for postoperative maintenance is 0.45% NaCl in 5% Dextrose. Fluid of choice for insensible loss is 5% Dextrose. Better Initial fluid in case of resuscitation to be Ringer's lactate and for maintenance be normal saline. In upper gastrointestinal fluid loss, normal saline with addition of potassium after

passage of urine, normal saline or Ringer's lactate for lower GI loss and Ringer's lactate and plasma for burns loss are the ideal. Blood loss up to 20% of the blood volume can be managed with fluids without replacing the blood loss. The recommended dose of IV fluid to be given is based on weight and the degree of dehydration. The maintenance fluid for the first 10 kg weight is 100 ml per kg per day and hence 1,000 ml, if child is 10 kg weight. For weight between 11 kg and 20 kg, 1,000 ml and 40 ml per every kg per day over 10 kg, thus 1,400 ml for 20 kg weight child. From 20 to 30 kg 20 ml per every kg per day is added to 1,400 ml for children above 30 kg weight add 10 ml per every kg excess of 30 kg to 1,600 ml for the 30 kg. The rate of administration is 4 ml per kg per hour for their first 10 kg, 2 ml per kg per hour for weight between 11 to 20 kg is added to 40 ml per hour for the first 10 kg and for children over 20 kg add 1 ml per every kg excess of 20 kg to 60 ml per hour. Based on the degree of dehydration the deficit is added to the maintenance fluid. In general shorter and acute the loss, the correction should also be quick. Fast correction can lead to volume overload, cerebral oedema and convulsions. Generally 50% of the total required fluid is given over the first 8 hours and remaining in next 16 hours. Initial rehydration should be fast using large bore needle until pulse is well felt. If dehydration is not improving then IV drip should be more rapid. Periodic assessment is essential so as to avoid dehydration as well as over hydration. Rehydration should be continued till all the signs of dehydration have disappeared.

### Signs of Overhydration

**CVS** Increased venous pressure, pulmonary oedema, and distention of peripheral veins, bounding pulse, high pulse pressure, increased cardiac output.

**Tissues** Earliest of all the sign to be weight gain and oedema of eyelid, subcutaneous pitting, anasarca and basal rales.

It is important to have an idea about the composition of IV fluid used in clinical practice (Table 9.1).

**Table 9.1:** Composition of commonly used IV fluids

	pH	Na <sup>+</sup>	Cl <sup>-</sup>	K <sup>+</sup>	Ca <sup>2+</sup>	Other components
Ringer's lactate	6.5	130	109	4	3	Lactate 28 mEq/L
Normal Saline	4.5	154	154	0	0	- (NS)
5% Dextrose	5	-	-	-	-	Dextrose 50 g/L

## BLOOD TRANSFUSION

Child's blood volume is 80 ml/kg. Therefore 20 ml/kg is a quarter of blood volume. Small amount of blood loss leads to shock, e.g. by the time the loss reaches 15 ml/kg, need to replace blood.

In the acute situations give bolus of 20 ml/kg of blood by syringe until circulation is restored.

In the elective situation for correction of anaemia packed red cells at 10–15 ml/kg over 4–6 hours.

3 ml/kg of packed red cells raised Hb  $\times$  1. 10 ml raises  $\times$  3 and 15 ml raises  $\times$  5 (Table 9.2).

**Table 9.2:** Blood volume according to body weight

Premature baby (26 weeks)	Term baby (40 weeks)	Adult
Body wt. 800 g	3,500 g	60,000 (F) 70,000 (M)
10% body weight	8% body weight	7% body weight
-Blood vol. 80 ml	-Blood vol. 280 ml	-Blood vol. 4,200 ml

### Haemoglobin Transfusion Formula

Desired Hb – Present Hb  $\times$  body weight kg  $\times$  80 = ml whole blood

Hct = 50% (packed red cells 50% of whole blood)

### Energy Requirements for Infants

Basal metabolism	—	50 cal/kg per day
Growth	—	25 cal/kg per day
“Energy thermogenesis”	—	45 cal/kg per day
Total	=	120 cal/kg per day

### Acid-Base Status

pH	—	7.25–7.43
pCO <sub>2</sub>	—	32–45 mmHg
pO <sub>2</sub>	—	> 50 mmHg
Base deficit/excess	—	Minus 4, plus 3 mmol/L
Standard HCO <sub>3</sub>	—	18–25 mmol/L

### Correction of Acidosis

Body weight (kg)  $\times$  base deficit  $\times$  0.3 = mmol NaHCO<sub>3</sub>  
8.4% NaHCO<sub>3</sub> 1 ml = 1 mmol

### Non-respiratory Acidosis

Body weight (kg)  $\times$  base deficit  $\times$  0.3 = mmol NaHCO<sub>3</sub>  
8.4% NaHCO<sub>3</sub> 1 ml = 1 mmol

## Non-respiratory Alkalosis

$\frac{1}{2}$  normal saline (77 mmol/L Na, 77 mmol/L)  
If urine output is good, add KCl 1 gm – 13 mmol to each 500 ml.

### SUMMARY

By getting detailed history it may be possible to exclude many conditions mimicking each other, and avoid unnecessary investigation, and in short, reduce the medical care cost and reduce the time between presentation and onset of treatment.

Preoperative and postoperative care are very important for successful management of the surgical patient.

Adequate knowledge of the fluid and electrolyte management of the surgical newborn, infant or child is mandatory for the optimal care of the surgical patient.

## PAEDIATRIC TRAUMA AND BURNS

### PAEDIATRIC TRAUMA

Trauma is the most frequent cause of death in children beyond infancy. Effective early management by those who are familiar with the management of paediatric trauma patients can significantly reduce morbidity and mortality. A common systematic approach to paediatric resuscitation has been developed which begins the treatment of life-threatening injuries/problems as soon as they are detected. The anatomy and physiology of children including their body proportions differ significantly from that of adults.

#### Head

Children have a large head to body size ratio that needs to be considered, in relation to heat loss, and surface area of burn patients. The head is 19% of surface area at birth, reducing to 9% at the age of 16 years. The neck must not be over extended as trachea is short and soft, and over-extension may cause tracheal compression.

#### Upper Airway

Infants less than 6 months are obligate nasal breathers. Narrow airways are often obstructed by mucus, loose teeth are at risk of being lost into the bronchial tree, and adenotonsillar hypertrophy is frequently present between 3 years and 8 years, adding to the difficulties of securing the airway. The epiglottis is more U-shaped in a child, projecting posteriorly at 45°.

The larynx is cephalad and anterior at cervical vertebrae C2-3 in the infant, as compared with C5-6 in the adult. It is therefore easier to intubate children younger than 12 months with a straight blade laryngoscope. The narrowest point of the upper airway is the cricoid ring, which is lined with pseudostratified ciliated epithelium, which is prone to oedema if cuffed tubes are used for intubation. Uncuffed tubes are used for all children who have yet to reach puberty, and the sizing of the tube should allow a small leak of gas past the tube during inflation of the lungs.

The trachea is short, in neonates 4–5 cm, in infants 7–8 cm and therefore tubes can easily become displaced accidentally or during transport, entering the relatively straight right main bronchus.

#### Neck

In children the interspinous ligaments and joint capsules are more flexible, the vertebral bodies are wedged anteriorly so tend to slide forward with flexion and the vertebral facet joints are flat. Cervical spine radiograph in children can cause some concern due to normal physiological appearances mimicking fracture or dislocation. It is important to link clinical examination and radiological findings. It is unusual to find a fracture without physical signs.

Skeletal growth centres can be confused with fractures. The basal odontoid synchondrosis has a radiolucent area at the base of the dens in children less than 5 years of age whilst the tip of the odontoid epiphyses appears separate in children aged 5–11 years. The growth centre of the spinous process can be mistaken for a fracture of the spinous processes.

Spinal injuries in children are rare but can occur. Spinal cord injury without radiological abnormality (SCIWORA) occurs almost exclusively in children less than 8 years old. It affects the C-spine and to a lesser frequency the thoracic spine, and is commoner in the upper C-spine segments due to the increased mobility of this region. Seriously injured children should be immobilised until full neurological assessment is possible. Magnetic resonance imaging may have to be used.

#### Fractures

Skeletal injuries in children can be difficult to detect, with only minor signs visible.

In the early stages of resuscitation, fractures should be thought of as a potential source of volume loss. Grossly displaced fracture/dislocations should be reduced. The blood loss from a long bone or pelvic fractures is proportionately greater in a child than adult. The majority of children's fractures heal rapidly and well. Whilst the bones are still growing there is a good capacity for bone

remodelling, so some angulation of a reduced fracture can be accepted. Fractures of the soft springy immature bones in children are often the classic greenstick fractures. Some injuries, such as crush injuries to the epiphysis are very difficult to diagnose radiologically, yet they can have serious consequences on the future growth and therefore symmetry of the limbs.

## PHYSIOLOGICAL PARAMETERS

The cardiovascular system in children has an increased physiological reserve compared to adults and is able to tolerate significant blood loss without obvious distress, there may only be subtle signs of severe shock. Hence early assessment and recognition of shock is essential for appropriate management of the injured child. Tachycardia and reduced capillary refill are frequently the only signs available.

The child's heart has a limited capacity to increase stroke volume so cardiac output is mostly dependent on heart rate. With a typical blood volume of 80 ml/kg, an amount of blood, which would otherwise be considered a minor blood loss in an adult, could severely compromise a child.

The child initially responds to reductions in intravascular volume by increased heart rate, and vasoconstriction with a low pulse pressure.

Shock in a child is difficult to recognise below 25% volume loss, but may be suggested by a weak thready pulse and an increased heart rate, lethargy and irritability, and cool clammy skin. There would be a slight reduction in urine output, if measured.

As volume loss approaches 25–45% the heart rate remains raised, but there is a definite reduction in consciousness and a dulled response to pain. The skin becomes cyanotic, with reduced capillary refill time (CRT) and the extremities become cold. If measured, there would be minimal urine output.

Finally above 45% volume loss the child can no longer compensate and there is a point at which the child becomes hypotensive and bradycardiac, and the child is comatose.

The normal physiological parameters of a child are given in Table 9.3.

As an approximate, guide  $\text{systolic BP} = 80 \text{ mm Hg} + \text{Age (years)} \times 2$

### Other Useful Guides

Weight =  $2 \times (\text{age} + 4)$

Blood volume =  $80 \text{ ml} \times \text{Weight in kg}$

Volume of dehydration =  $\text{Weight in kg} \times \% \text{ of dehydration} \times 10$

**Table 9.3:** Normal physiological parameters

Age	Weight (Kg)	Heart rate per min	Blood pressure (mmHg)	Respiratory breath/min	Urinary output ml/kg/hr
0–6 months	3–6 kg	140–160	60–80	40–60	2
Infant	12	140	80	40	1.5
Preschool	16	120	90	30	1
Adolescent	35	100–50	100	20	0.5



**Fig. 9.1:** Showing the injury mark on the inner surface of the cheek of a 6-year-old boy bitten by dog

## APPROACH TO THE INJURED CHILD

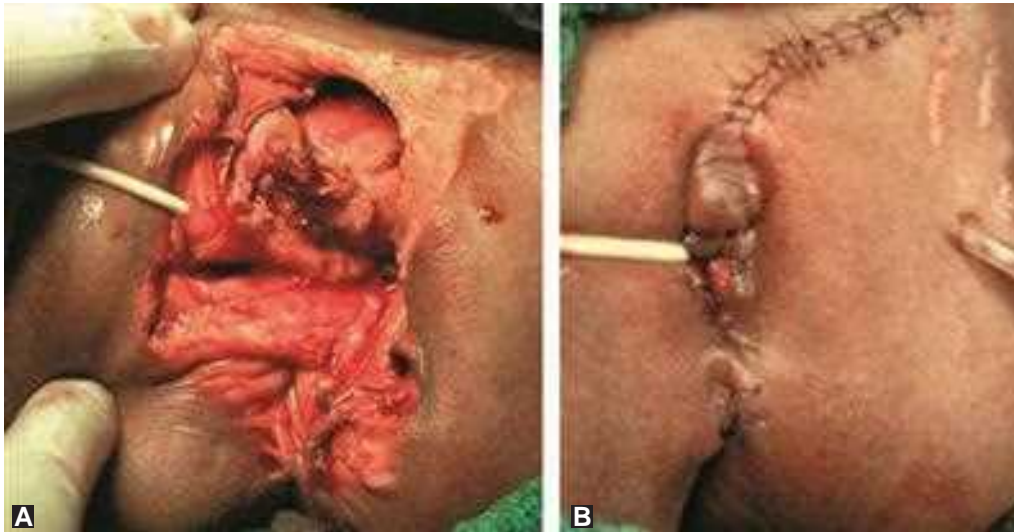
A proper history should be taken from the parents or the guardian regarding the mode of injury and the duration elapsed between the time of injury and the time the patient is being examined. The mode of injury may vary from a dog bite (Fig. 9.1) to a fall from height (Figs 9.2A and B).

The approach is to be found in greater detail in the manuals of the Advanced Trauma and Life Support, Paediatric Advanced Life Support and Advanced Paediatric Life Support. The ATLS approach to paediatric trauma is given in the Table 9.4.

### The Primary Survey

The aim is a rapid assessment to identify immediate life-threatening problems and prevent secondary injury.

- A** Airway and cervical spine control
- B** Breathing and ventilation



**Figs 9.2A and B:** A case of perineal trauma in a girl child: (A) Before repair showing the injury through the pubic symphysis up to behind the rectum; (B) After repair with urinary catheter in situ

**Table 9.4:** ATLS approach to paediatric trauma

#### Prepare

- Room and equipment
- Staff: nursing, radiology, lab, RTs
- Discuss case/interventions
- Paramedic report

#### Primary survey (assessment and management)

- Airway
- Breathing
- Circulation
- Disability
- Exposure
- Full vitals

#### Adjuncts to primary survey

- Pulsox, cardiac monitors, BP monitor, CO<sub>2</sub> monitor
- NG tube
- Foley
- ECG
- X-rays: C spine, CXR, pelvis
- Trauma blood work
- ABG
- DPL/ABUS if appropriate

#### Secondary survey

- AMPLE history—Allergies, medication, past illness, last meal, events related to injury
- H/N
- Chest
- Abd
- U/G
- Neuro

- Msk
- Roll pt

#### Adjuncts to secondary survey

- X-rays
- CT head, chest, pelvis, abdomen, spine
- ABUS
- DPL
- Contrast studies
- Endoscopy
- Angiography
- Oesophagoscopy
- Bronchoscopy

**C** Circulation and control of haemorrhage

**D** Disability

**E** Exposure and control of environment

Endotracheal tube size (mm) = 4 + Age (years)/4, which should be close to the diameter of the little finger or the size of the nares. An uncuffed tube is used which sits in position at the cricoid ring.

Children's normal ventilatory rate varies and reduces with age. Tidal volume is of the order of 7–10 ml/kg. Care should be taken when assisting ventilation to match these parameters without using excessive force, which can cause barotrauma to young lungs.

Assessment of parameters to gauge the stage of shock includes pulse, systolic blood pressure, capillary refill time, skin colour, temperature, respiratory rate and mental status.

Capillary refill time (CRT) is measured by squeezing and elevating an extremity, great toe or thumb, above heart level, for 5 seconds, then releasing it.

CRT more than 2 seconds, skin mottling, and low peripheral temperature are signs of shock.

When shock is suspected 20 ml/kg of warmed crystalloid solution is used. Failure to improve suggests either ongoing haemorrhage or gross fluid depletion. This 20 ml/kg represents 25% of blood volume, but as this volume becomes distributed into other body fluid compartments up to three boluses of 20 ml/kg may be necessary to achieve 25% blood volume replacement. If a third bolus is being considered then blood replacement should be considered.

Disability is assessed by pupil size, reactivity and conscious level as alert, responsive to voice, responsive to pain and unresponsive.

All surfaces of the child need to be inspected during the course of the primary survey, but this can be done region by region to avoid distress and heat loss.

### Secondary Survey

The secondary survey is a head to toe assessment, including reassessment of vital signs.

A complete neurological exam including the GCS should be carried out.

A brief medical history needs to be recorded.

Standard trauma blood investigations are taken during IV access and primary survey.

Radiological investigations are required as an adjunct.

Blood tests: Baseline

Full blood count, electrolytes, glucose, amylase

Blood for group and save or Urgent cross match

Arterial blood gases

X-ray trauma series—Chest, C-spine, Pelvis

Additional investigations are taken when the patient is stabilised.

## EMERGENCY TREATMENT

Emergency treatment is that required to stabilise the child prior to transfer to an appropriate referral centre, theatre for operative treatment or the ward for conservative expectant observation.

### Head Trauma

Head injury is the most common reason for hospital admission in children, and the most common cause of death in children after the age of 1 year. Fortunately many injuries are trivial and their admission to hospital is mainly to reassure parents and cover the hospital.

The standard trauma and resuscitation approach is used in the assessment and early treatment of these patients and

the aim of emergency treatment is directed at preventing secondary brain injury, and referring early to a neurosurgical unit for definitive treatment.

### Primary and Secondary Brain Injury

Neurosurgical referral is indicated if there is a deteriorating conscious level or coma score less than 12, focal neurological signs, depressed skull fracture or penetrating injury, or basal skull fracture. Definitive treatment is directed at the cause of the raised intracranial pressure or injury. This may involve the evacuation of haematoma or elevation of depressed fracture in addition to other intensive care measures.

Any child with a Glasgow Coma Scale (GCS) of 8 or less should be intubated and ventilated with rapid sequence anaesthesia.

If the conscious level deteriorates rapidly despite all other supportive measures, then urgent referral is indicated and measures intended to increase cerebral perfusion in the short term are used. These include the use of:

- IV mannitol 0.5 to 1 g/kg
- Hyperventilation to a PaCO<sub>2</sub> of 3.5–4.0 kPa
- 20° head up position to promote venous drainage
- Plasma expanders to avoid cerebral hypotension.

A focal seizure is considered as a focal neurological sign.

Generalised fits are of less concern but should be controlled if they have not stopped within 5 minutes. IV diazepam is preferred.

In many cases the head injury is limited to minor scalp haematoma, limited vomiting with normal neurology. If the head injury appears stable, a period of close observation for 24 hours is appropriate.

The assessment of head injuries in children depends on the age of the child, their ability to describe the mechanism of injury, and the history obtained from reliable witnesses. Potentially serious injuries are suggested by significant energy transfer, e.g. road traffic accident (RTA) or fall from height more than 2 m, loss of consciousness (LOC), an altered state of consciousness, obvious neurology, or penetrating injury. The conscious level should be documented using the appropriate scale for the age of the child and the time noted.

### Thoracic Trauma

Children have elastic ribs and significant amounts of energy can be absorbed by the thoracic region without obvious external signs of injury. An apparently normal chest radiograph cannot exclude significant thoracic injury.

The presence of rib fractures therefore suggests a very significant transfer of energy and other associated organ injuries should be suspected.

The provision of high flow oxygen via a reservoir mask allows  $\text{FiO}_2$  of greater than 60% to be achieved and should be used routinely in chest trauma.

Chest injuries which can occur include those which can be immediately life-threatening and those which become apparent later.

### *Tension Pneumothorax*

Air is drawn into the pleural space compressing the mediastinum and compromising venous return to the heart. Cardiac output reduces, so that the child becomes hypoxic and shocked, and the jugular veins become distended.

There will be hyper-resonance and reduced air entry on the lung field on the side of the pneumothorax. As the mediastinum is pushed to the opposite side the trachea is said to deviate away from the side of the pneumothorax.

Treatment should be immediate, needle thoracocentesis in the 2nd intercostals space mid clavicular line, relieving the tension and converting the injury into a simple pneumothorax. Definitive treatment is the insertion of a chest drain.

### *Major Haemothorax*

Bleeding into the pleural space from damage to the lung vessels or chest wall can be a source of a large volume of blood loss, in addition to the reduction in lung volume, shock and hypoxia may be evident if significant blood volume has been lost. There will be reduced chest movement, reduced air entry and reduced resonance to percussion on the side of haemothorax.

Treatment requires volume replacement and the insertion of a large bore chest drain.

### *Open Pneumothorax*

The presence of penetrating wounds to the upper body, between umbilicus and root of the neck must alert one about the possibility of an open pneumothorax.

There will be reduced chest movement, reduced breath sounds and hyper-resonance on the side of the pneumothorax. Air may be heard to suck and blow through the wound. Treatment requires the creation of a flap valve using an airtight dressing secured on three of four sides, to allow air out but not in, preventing a tension pneumothorax developing and converting the injury into a simple pneumothorax. A chest drain is required, followed by surgical exploration, debridement and repair.

### *Flail Segment*

In the child a flail chest is a very significant injury due to the amount of energy required to create it and the degree of underlying lung injury. Abnormal chest movement may be seen over the flail segment and crepitus may be felt. The

early involvement of the anaesthetist is advised. Treatment should consist of endotracheal intubation and ventilation.

### *Cardiac Tamponade*

Injury, which causes bleeding into the pericardial sac, reduces the volume available for cardiac filling. As the pericardial sac fills with more blood the cardiac output is reduced. Shock develops, the heart sounds become muffled and the neck veins may become distended. Treatment is pericardiocentesis, which may need to be repeated.

### **Abdominal Trauma**

The abdomen is more exposed in children than in adults. The soft elastic rib cage offers less protection to the liver kidneys and spleen. The pelvis is shallow and the bladder is intra-abdominal in the younger child. The most common organs to be damaged following blunt trauma are in order, spleen, liver, kidney, gastrointestinal tract, genitourinary tract and pancreas. Penetrating trauma most commonly affects the gastrointestinal tract, liver, kidneys and blood vessels. The significant morbidity and mortality following splenectomy has led to a more conservative approach to possible splenic trauma. Experience has shown that the majority of abdominal injuries can be treated conservatively provided they receive close observation, repeated assessment and monitoring. Attention should be paid to vital signs, fluid balance and blood factors. A paediatric surgeon should be available during this period if required.

Operative intervention is required in:

- Haemodynamically instability after the replacement of 40 ml/kg of fluid
- Penetrating abdominal injury
- A non-functioning kidney is demonstrated on contrast study (remembering the warm ischaemic time for the kidney is a maximum of 60 minutes)
- Signs of bowel perforation.

The abdomen is only considered in the primary survey under C circulation if shock does not respond to volume replacement, if no other obvious site of haemorrhage can be found. In children, a nasogastric/orogastric tube should be passed as air swallowing occurs during crying and can cause significant gastric distension. Gastric distension can cause splinting of the diaphragm making breathing and/or ventilation difficult.

During the secondary survey the abdomen is inspected for bruising, laceration, penetration. The external genitalia must also be examined and the external urethral meatus inspected for blood. If blood is seen this is an indication for retrograde urography and passage of urethral catheter must not be attempted by anyone other than a consultant urologist.



Rectal examination on children is carried out only if it is considered appropriate by the paediatric surgeon who would be operating.

### CHILD ABUSE

Child abuse can take many forms, physical, sexual, emotional, or neglect. It is important to have a high index of suspicion of the possibility of abuse and be aware of the patterns of presentation, explanations and injury seen.

Factors which should alert the doctor to the possibility of non-accidental injury (NAI) include, odd times of presentation for treatment, delayed presentation, presenting without the prime carer, inconsistent and imprecise times and accounts of the mechanism of injury. The injury may not be compatible with the mechanism of injury, or the parents' attitude or focus of concern does not seem right. Perhaps the child's interaction with the adult is abnormal, or their behaviour seems inhibited or withdrawn.

Injuries seen in NAI include head injuries, including occipital fractures and intracranial injury. Fractures of long bones and particularly multiple fractures at different stages of healing may be seen. Bruising and finger marks in a hand print distribution, burns, scalds, cigarette burns, belt, bite marks should all be carefully examined.

Sexual abuse may present as frank injury, genital infection, or may present with odd inappropriate behavioral or other emotional problems.

Assessment of any child with suspected child abuse needs great care and sympathy, and the involvement of seniors at the earliest point of concern.

### Trauma Scores

Trauma scores are used as a predictor of survival and for comparative purposes and are given in the Tables 9.5 and 9.6.

**Table 9.5:** Paediatric trauma score

	Coded value		
Patient factors	+2	+1	-1
Weight (kg)	> 20	10-20	< 10
Airway	Normal	Maintained	Not maintained
Systolic BP	> 90	50-90	< 50
CNS	Awake	Obtunded	Coma
Open wound	None	Minor	Major
Skeletal trauma	None	Closed	Open/Multiple

**Table 9.6:** Revised trauma score

This is a physiological scoring system consisting of a weighted combination of Glasgow Coma Scale, Systolic blood pressure and respiratory rate.

Glasgow coma scale score	Systolic blood pressure	Respiratory rate	Coded score
13-15	> 89	10-29	4
9-12	76-89	> 29	3
6-8	50-75	6-9	2
4-5	1-49	1-5	1
3	0	0	0

RTS = 0.94 GCS + 0.73 Systolic BP + 0.29 Respiratory Rate

The RTS can be in a range between 0 and 7.84.

When RTS is plotted against survival a sigmoid-shaped curve is produced.

### BURNS

Burns are the most devastating type of trauma that the human beings suffer. The post-burn scars leave behind indelible blemishes, and the victims may suffer till the end of their lives. The incidence of burn injuries is increasing and today children suffer from burns more and mortality is also high. Significant morbidity in terms of burn complications, such as functional, cosmetic, social and psychological impairment is also seen. Children are at high risk because of their natural curiosity, their mode of reaction, their impulsiveness and lack of experience in calculating the risk of the situation.

### Epidemiology

Children unfortunately are the innocent victims of circumstances that result in major fire accidents. Superficial flame burns rate the highest amongst the aetiological factors. Scalds due to hot liquids in the domestic setup rank next in the aetiology. More serious types of scalding occur when older children 2-4 years fall into the hot water or hot milk kept on the floor for cooling under the fan (Fig. 9.3). Neonates suffer burns due to hot water bottles, which are used as warmers.

Electrical burns are very common in the domestic setup, when children place their fingers into open plug socket and suffer low voltage burns. Playing near dish antenna on the top of multistoried buildings could result in serious high voltage electrical burns in the upper limbs. Contacts with live wires are a common type of electrical burn when children play and try to retrieve kites. These could result in major burn injuries with wound of entry and wound of exit.

Acid burns are not very common in children, but corrosive oesophageal injury occurs due to accidental ingestion of acid, which is kept in kitchen closets for cleaning purposes.

Children sometimes are innocent victims of homicidal acid burns.

### Pathophysiology of Burns

Problems in the paediatric burns are mainly due to physiological immaturity; this is especially true in infants. The temperature regulating mechanism is labile as the ratio of surface area of the body to weight is more. Rapid shifts in the core temperature occur. Deep burns occur rather rapidly due to the thin skin of the infant that has scant dermal appendages, which are close to the surface, permitting the burn to penetrate into the depths easily. Children are also more susceptible to fluid overload and dehydration. Infants require higher energy and their peripheral circulation is labile. Their metabolic demands are also on the higher side. With all these special problems, the children with burns present a special management issue.

Burn shock is consequent to the massive fluid shifts that occur soon after burn injury. Direct thermal injury results in changes in the microcirculation and capillary permeability increases. Multiple inflammatory mediators are also secreted which increase the vascular permeability throughout the capillary vascular bed all over the body. This results in the leak of intravascular fluid into the extra-vascular spaces resulting in burn oedema, which is maximum at the end of 12 hours post-burn in minor burns and lasts till 24 hours in major burns. Hypovolaemia occurs due to the fluid shifts at the expense of circulating blood and plasma. This results in burn shock with reduced cardiac output, increased heart rate, increased pulse rate, oliguria, acidosis and air hunger. The inflammatory mediators that are responsible are Bradykinin, Histamine, Prostaglandins, Leukotrienes and hormones. Products of platelet degradation and interleukin-1 (IL-1), and IL-6 also act as mediators of burn shock.

In burnt patients the levels of sodium adenosine triphosphate are reduced in the tissues, which alters the cell transmembrane potential and the concentration of sodium increases in the extravascular compartment. This also contributes to burn oedema.

### Classification of Burns

Classification of burns can be done according to the agent inducing the injury and according to depth and extent of the total body surface area (TBSA) involved.

#### Depth

A clear understanding of the depth and structure of the skin is needed to understand the grades of burn.



Fig. 9.3: The healing wound of a baby who was affected by third-degree burns

#### First-Degree Burn (Superficial)

Only the superficial epithelium is involved. There is always varying degree of erythema and regardless of the type of therapy used, this type of burn heals without scar formation. For about 6–10 hours, burn is painful and then gradually it becomes less painful. Sunburns and flame burns are generally of this type.

#### Second-Degree Burn (Partial Thickness)

Here the entire epidermis and a variable depth of dermis are involved. These are commonly seen due to splashes of hot liquids, flash burns, longer contact with flames and limited exposure to chemicals. Depending upon the extent of dermal involvement it is further divided into superficial and deep partial thickness burn.

The superficial type is painful and has blisters. Since sweat glands and hair follicles are spared the healing is satisfactory and scarring does not occur. These heal in 2–3 weeks time and are painful during healing phase due to regeneration of nerve fibres.

The deeper variety is not very painful and is generally without blisters, but since the reticular layer of the dermis is involved these usually do not heal spontaneously, and when

it heals after several weeks, it does so with hypertrophic scarring. The appearance will be almost like third-degree burn. A sterile 'pin-prick test' with a hypodermic needle can be very valuable in assessing the depth of the burn.

### *Third-Degree Burn (Full Thickness)*

Here the entire thickness of the skin and adnexae are involved. The burn is not very painful and is parchment like in appearance. These do not heal spontaneously and have to be excised and grafted. When the third-degree burn is extensive, it gives rise to a systemic response, which may result in shock. If it is allowed to heal by itself, it may result in crippling contractures. These are seen due to prolonged contact with any of the agents causing second-degree burns as seen above.

### *Fourth-Degree Burn*

Involvement of tissues and structures beneath the skin, such as muscles and bones signifies a fourth-degree burn. These are obviously insensate and a charred appearance is seen. Classically seen due to molten metal, high voltage electrical burns and prolonged contact with flames.

### **Extent of Burn**

TBSA burnt should be quantified early in assessment; it is the single most important factor for management and prognosis. There are various methods to calculate it:

- Rule of nines: According to this algorithm head and neck comprise 9% of BSA, front and back of trunk—20% each, each arm—9%, front and back of leg—9% each and the remaining 1% is made up by the genitalia. This rule is quite reliable in patients who are greater than 15 years old but is not suitable for use in children.
- According to palm hands: A rough estimate of the BSA burnt can be made by the number of palm hands of the patient required to cover the area. Palm surface area roughly equals 1% across all age groups.

### **Burn Wound Healing**

Skin is the largest organ in the body, with multi-structural and multi-functional components with regional variations. The ischaemic, hypoxic and edematous burn wound takes a very slow course for healing compared to a traumatic wound. Unique characteristics of burn wound healing requires a thorough understanding of normal wound healing which is a very complex and dynamic process consisting of many co-ordinated cellular, biochemical molecular processes. The wound healing goes through phases of angiogenesis, granulation tissue formation, processes of

matrix formation, remodelling and epithelialisation to the formation of a scar.

### *Epithelialisation*

In a regular wound, epithelialisation begins within hours after injury. In superficial and superficial partial thickness burns epithelialisation occurs spontaneously from the dermal remnants of hair follicle and sebaceous glands. In deep partial thickness burns the epidermal cells undergo phenotypic alteration at the margins of the normal skin and lose their adherence to one another and to the basement membrane, which allows for the lateral movement of epidermal cells. The migrating epidermal cells dissect the wound space separating the eschar from viable tissue guided by an array of integrins, which the migrating cells express on their cell membrane. One or two days after injury the epidermal cells at the wound margin begin to proliferate behind the actively migrating cells. The stimulus for proliferation and migration of epidermal cells is epidermal growth factor. If the area of the burn is large, re-epithelialisation may not completely cover the raw wound and split skin grafting may be necessary to hasten the wound healing. In smaller burn areas, within 10–12 days, epithelialisation is complete and the burn wound gets closed.

### **Pathophysiology of Burn Shock**

A clear understanding is necessary to plan the treatment in paediatric burns and to organise the resuscitation schedule.

Burns shock is the result of vascular changes that take place immediately after burns. Direct thermal injury results in changes in the microcirculation and capillary permeability. The latter increases and alterations in the transcell membrane potential occur. These occur due to certain mediators like Bradykinin and Histamine. This increased capillary permeability results in massive fluid shifts from the intravascular to extravascular compartment. The total body fluid volume may remain unchanged, but the volume of each compartment gets altered. For normal maintenance of ionic gradient across the cell membrane, adequate levels of Na-adenosine Triphosphatase are required. In burns the level of Na-ATPase decreases and consequently sodium concentration in the cells increases and intracellular oncotic pressure increases. This results in massive oedema in the burnt tissue, hypovolaemia and oliguria, which are the components of shock. Intracellular and interstitial volume increases at the expenses of plasma and blood volume. Other mediators, which have been identified in this process, are products of platelet degradation, prostaglandins, leukotrienes, IL-1, IL-6 and TNF- $\alpha$ . The formation of oedema is maximum by the

end of 12 hours post-burn in minor burns and lasts till 24 hours in major burns.

### Immunological Response to Burn Injury

Today it has been realised that in massively burnt patients (> 40% TBSA) chaotic cytokine array is responsible for higher mortality rate and not infection as was thought earlier. The appropriate term for the immunological failure that is seen is 'systemic inflammatory response'. As soon as burn injury occurs, macrophage margination and activation occurs. This results in the release of three cytokines IL-1, IL-6 and TNF- $\alpha$ . Macrophages also produce products of lipid peroxidation namely leukotrienes and prostaglandins. All these are very toxic to the patient and these produce T cell failure, inhibit lymphocytes, haemoglobin synthesis and also depress the granulocyte colony formation.

Skin is recognised as the largest immune organ and the effect of heat could well figure in the origin of the pathophysiology encountered. The area of skin burnt quantitatively is related to mortality and cellular functional failure. This immune failure could be the cause of death in children during the shock phase, rather than infection.

## EMERGENCY ROOM MANAGEMENT

The initial management of the severely burned patient follows the guidelines established by the Advanced Life Support course of the American College of Surgeons according to which, like any other trauma, airway and breathing assume the highest priority.

### Airway and Breathing

Airway management is the first and the foremost priority as there is high incidence (up to 30%) of associated inhalation injury in a severely burnt patient which can be immediately life-threatening. Inhalation injury may be present with minimal cutaneous burns and may not be evident at presentation but can develop rapidly. Inhalation injury should be suspected if there is any history of exposure to smoke in a confined space, level of consciousness (LOC), impaired mental status or disorientation and obtundation. Important clinical signs to be looked for are—any hoarseness of voice, stridor (impending airway obstruction), facial burns, singed nasal hair, wheezing and expectoration of black carbonaceous sputum. Affected patients should be given 100% oxygen by mask (to wash out carbon monoxide), oxygen saturation should be monitored and equipment kept ready for intubation. Ideally fiberoptic bronchoscopy should be done on any suspicion and signs, such as airway oedema, mucosal necrosis, haemorrhages, ulcers and pseudomembranous casts should be looked for. If any of these are present, the patient should be intubated

and respiratory care protocol established. The final point to be remembered is the fact that the burn patient could also be a victim of associated trauma, hence decreased levels of consciousness or oxygen desaturation should not be blamed only on burn shock or inhalation injury, but could be due to associated head injury.

### Circulation and Intravenous Access

It is important to start two intravenous portals, one for infusing fluids and the other for giving drugs through the unburnt skin. Central line though ideal, may invite sepsis and could be disastrous and hence should be inserted only if required urgently. If the child has already gone into shock with falling blood pressure, then a central line must be started. Adequate fluid resuscitation should be started and a Foley's catheter should be placed. A nasogastric tube should be placed to drain the stomach.

### Eliciting History for Medicolegal Purpose

To ensure proper epidemiological documentation and also for medicolegal records, a detailed history should be elicited from the conscious patient and in the case of children from the parents. This would enable implementation of preventive programme.

### Recording of the Weight of the Patient

Recording of the weight of the burnt child is important for calculating and administering fluids and drugs. Ideally weight is recorded as soon as possible at the emergency room.

### Investigations

When the IV portals are started, blood is drawn for serum chemistry and a sample is refrigerated for grouping and cross-matching.

### Escharotomy and Fasciotomy

Burn eschar may act an inelastic constricting tourniquet impairing circulation and even respiration. This is seen generally in extremity and chest burns though can occur in neck and abdominal wall burns also. This phenomenon is seen only with deep second- and third-degree burns only. The constricting effect may not be there initially and develops later on during resuscitation; 8–24 hours period is most critical period. A frequent assessment of the peripheral perfusion can help in early diagnosis. Parameters to be checked are capillary filling time, pulses and oxygen saturation. Doppler can aid the diagnosis in difficult cases. For prevention, extremities with deep burns should be kept elevated and splinted in a functional position. If signs of vascular insufficiency appear then escharotomy should be performed without delay. This

procedure involves an incision through the burn eschar to relieve the constriction caused by it. This procedure can be done at the bedside with an electrocautery with the patient under sedation, as the eschar is insensate. A rapid restoration of the circulation suggests a successful procedure; if the blood flow is still not restored then a consideration should be given to fasciotomy, i.e. incision of the deep fascia to alleviate the compartment syndrome.

### Fluid Resuscitation in Paediatric Burns

It is important to bear in mind that a burnt child continues to be a special challenge, since resuscitation therapy must be more precise than that for an adult with a similar burn. Important point to bear in mind is the fact that a burnt child requires intravenous resuscitation for a relatively smaller TBSA (10–20%) unlike an adult. Primary goal of resuscitation is to support the child throughout the initial 24–48 hours period of hypovolaemia that sets in due to extravascular fluid sequestration during post-burn shock period.

### Calculation of the Requirements

Cope and Moore in 1947 gave the first rational scheme of fluid resuscitation in burn patients. Though their formula is no longer in use all the modern formulas derive their basic scheme from their formula, i.e. requirements are calculated according to the extent of the burn and the weight of the patient, initially for the first 24 hours. Half of this amount is given in the initial 8 hours and the rest over next 16 hours. Though for adults Parkland's formula is the one that is in most common use, the only formula for calculation in paediatric burn patients is the one devised by Shriners Burn Hospital. According to this formula:

- For first 24 hours: Total fluid requirement is  $5,000 \text{ ml/m}^2 \text{ TBSA burn} + 2,000 \text{ ml/m}^2$  as maintenance, 50% of this volume is given in initial 8 hours and the rest in ensuing 16 hours. Ringer's lactate is the fluid used for resuscitation.
- Thereafter:  $3,750 \text{ ml/m}^2 + 1,500 \text{ ml/m}^2$  is used for next 24 hours; a part of total of it may be made up by the enteral feeds. Urine output of more than 1 ml/kg per hour and stable vitals signify an adequate replacement.

### Place of Colloid

There is a controversy regarding the use of colloids in the initial resuscitation scheme. It is known that the plasma proteins are extremely important in the circulation since they generate the inward oncotic force that counteracts the outward capillary hydrostatic force. But protein solutions are not given in the initial 16 hours, as they also leak through the dilated capillaries, and are no more effective than more salt water. After 16 hours, if colloids are added to the crystalloid

regimen, the reversal from shock is phenomenal. Either fresh frozen plasma 0.5–1 ml/kg TBSA or 5% albumin can be given.

### Place of Whole Blood

In extensive third-degree electric burns or in third-degree burn over 50% TBSA, actual entrapment of RBCs and cell death results in severe hypoxia. This situation can be reversed by whole blood transfusion and preferably fresh blood improves the situation better. Fresh whole blood transfusion is usually given. This can be combined with crystalloids.

### Urine Output Monitoring

Measured volume bags are preferably used. Child should void 1 ml/kg per hour of urine if resuscitation is adequate.

Diuretics are generally not indicated during acute resuscitation period. But in children sustaining high voltage electrical burns with myoglobinuria/haemoglobinuria, there is increased risk of renal tubular obstruction. Forced alkaline diuresis is indicated in such situations with urine output as high as 3–5 ml/kg per hour. To alkalinise the urine, sodium bicarbonate is added, while an osmotic diuretic like mannitol achieves a high urine output.

### Problems in Resuscitation

It is important to identify acidosis. Electrolyte estimation must be done periodically and acidosis must be corrected without delay. There is a risk of hyponatraemia and hyperkalaemia early on.

Thermal injury results not only in massive fluid shifts that cause hypovolaemia, but also in release of inflammatory mediators from burn wounds. These mediators deleteriously affect cardiovascular function and lead to burn shock. The end result of a complex chain of events is decreased intravascular volume, increased systemic vascular resistance, decreased cardiac output, end organ ischaemic and metabolic acidosis. Without early and full resuscitation therapy these derangements progress to acute renal failure, cardiovascular collapse and death.

Resuscitation in itself is not without complications. Burn oedema is worsened with resuscitation, particularly crystalloid solutions. The above given formulae are generalisations only; each child should get individualised treatment to avoid complications.

### Infection Control

Infection is the most common complication seen in the burn patients. Initially gram-positive organisms are the ones that cause sepsis but as early as 3 days post-burn gram-negative organisms start predominating. Systemic antibiotics are not recommended in burn patients for prevention of burn wound

sepsis, as the burn tissue is a poorly perfused tissue. Also this practice leads to the emergence of resistant strains. They are certainly recommended in special circumstances such as:

- Perioperatively: Around the time of burn wound excision to limit the incidence of bacteraemia. They should be guided by the quantitative burn wound cultures.
- Autografting: At the time of autografting to prevent local loss of the graft and also to prevent infection at the donor site. A first generation oral cephalosporin is good enough till the first dressing change if the cultures are not available.
- Infection elsewhere: In the presence of infection elsewhere, such as pneumonitis, thrombophlebitis, urinary tract infection and sepsis, systemic antibiotics are obviously indicated.

Topical therapy is all that is required for most of the burn wounds. Appropriate topical therapy reduces microbial growth and chances of invasive sepsis. It should be soothing in nature, easy to apply and remove and should not have systemic toxicity. Such an ideal anti-microbial probably does not exist.

**DRESSINGS:** Option of closed dressing and open dressing methods are available. In open method, topical anti-microbials are applied and the wound is left open to warm dry air. *Pseudomonas* infections are rare but this method requires a strict environmental control and is painful. The fluid requirements also increase due to greater evaporative losses. This method is useful for facial and scalp burns. In closed dressings topical anti-microbial creams are applied and then covered with gauze dressings. This method is less painful though more labour intensive. Closed dressings are preferred for the extremities and over the back.

## SURGICAL MANAGEMENT OF THE BURN WOUND

A proper assessment of the burn wound guides the choice of the surgical therapy.

- First-degree burn: As there is minimal loss of the barrier function of the skin, the infection and fluid loss are not common. Management aims at providing pain relief and optimal conditions for wound healing. Topical salves and oral analgesics are the only medications required.
- Superficial second-degree burns: These require daily dressings with topical anti-microbials till spontaneous re-epithelialisation occurs in 10–21 days. Alternatively, temporary biological or synthetic dressings can be used.
- Deep second-degree and third-degree burns: Early burn wound excision has been shown to be beneficial in these types of burns.

Advantages are:

- Decreased rates of infection as dead and devitalised tissue is removed

- Removal of source of inflammatory mediators
- Decreased scarring and more functional rehabilitation
- Decreased stay in hospital
- Early excision (< 48 hours) is associated with less blood loss.

Two types of burn wound excisions are described:

1. Tangential excision: Implies sequential excision of burnt skin layers to reach the viable tissue layer. It is more time consuming and is associated with more blood loss and requires a certain experience.
2. Fascial excision: This involves removal of all tissue down to the level of deep fascia. This procedure is technically easier and is associated with comparatively less blood loss. As this procedure is cosmetically disfiguring it should be used in only compelling situations, such as life-threatening burn wound sepsis.

Blood loss during surgery can be controlled by use of tourniquets, elevating the limb and local application of thrombin solution or epinephrine soaked pads.

## Wound Coverage

After burn wound excision, the tissue bed consists of dermis and the subcutaneous fat. It is necessary to cover this raw area to promote healing and to provide for better cosmetic and functional outcome.

- Autograft: Ideal coverage is the patient's own skin. It is generally possible to get enough split skin autograft in less than 40% TBSA burns. Meshing allows more area to be covered and also allows for seepage of the exudates in the postoperative period. Maximum meshing allowed is 4:1. More meshing ultimately leads to more scarring; for this reason the grafts to be used on face and joints should preferably not be meshed.
- Autograft with allograft overlay: If the autograft is inadequate, a 4:1 or even 6:1 meshed autograft is used and over it 2:1 meshed allograft is placed. Allograft falls away as the autograft epithelialises underneath. In massively burnt patients, rejection is not a major issue as there is profound immunosuppression. It is mandatory to screen the donor for HIV, CMV, HBV and HCV before using these grafts.
- Allograft: Allograft can be used for temporary coverage of the wound till the donor sites heal and further grafts can be taken from them. Such situations can arise in massively burnt patients (> 40% TBSA).
- Xenograft: Porcine skin is readily available and it resembles human skin morphologically. It adheres well to the dermis and then is gradually degraded; the main drawback is its inability to prevent infection.
- Amniotic membrane: Amniotic membrane can provide an excellent temporary biological coverage till more autograft is available. It is freely available, is non-

antigenic and has some infection resisting properties. Cord blood sample should be tested for HIV, CMV, HBV and HCV prior to its use.

- Synthetic dressings: Various biologically engineered membranes, such as keratinocyte sheets, silicon mesh with porcine or human collagen and silicon mesh with foetal keratinocytes are available in the west but their cost and availability still precludes common clinical use.

Reasons for the non take-up of grafts:

- Fluid collections underneath the grafts—meticulous haemostasis, meshing and good pressure dressings help prevent this complication
- Shearing stress on the grafted surfaces—can be prevented by proper immobilisation and splinting
- Infection—good perioperative antibiotic cover based on cultures should be used
- Residual necrotic tissue in the bed—adequate excision takes care of this aspect.

Proper care of the donor sites to allow for reuse cannot be overemphasised, as every inch of the skin is precious. Donor area if not properly cared for behaves in the same way as a second-degree burn.

## Hypermetabolic Response and Nutrition

### *Hypermetabolic Response*

Burns more than 40% TBSA cause a tremendous increase in the resting energy expenditure amounting to even 50–100%. The following factors contribute:

- Increased release of IL1, IL2, TNF- $\alpha$ , thromboxane.
- Increased release of stress hormones, such as catecholamines, glucagon and cortisol.

All these promote systemic vasoconstriction and may lead to renal and mesenteric ischaemia. This hypermetabolic response can be modified to improve the outcome:

- Ambient temperature should be kept between 28°C and 30°C
- Early enteral nutrition in the post-burn period reduces the incidences of bacterial translocation and counters the catabolic state
- Beta-blockers can block the deleterious effects of catecholamines to decrease the heart rate and the cardiac output
- Growth hormone has also been shown to help in catch-up growth by fostering a positive nitrogen balance. It also improves immunity and helps in faster healing at the donor sites
- Adequate pain relief also helps in decreasing the stress response. Specially during dressing changes intravenous

pethidine can make dressing changes less distressful for these sick children.

### *Nutrition*

Early establishment of enteral feeds as soon as the child is stabilised via a nasogastric tube decreases the metabolic rate, gastric atrophy, stress ulceration and bacterial translocation. Parenteral nutrition leads to more chances of systemic sepsis, thus enteral route with all its advantages is preferred. An adequate calorie intake provided as 40–70% carbohydrates, 10–20% fats and 20–40% protein should be the goal. Calorie requirement is calculated according to the Shriners Burn Institute formulas.

- Infant formula: 1,800 kcal/m<sup>2</sup> maintenance + 1,000 kcal/m<sup>2</sup> area burnt
- For 1–11 years: 1,800 kcal/m<sup>2</sup> maintenance + 1,300 kcal/m<sup>2</sup> area burnt
- More than 12 years: 1,500 kcal/m<sup>2</sup> maintenance + 1,500 kcal/m<sup>2</sup> area burnt.

## COMPLICATIONS AND REHABILITATION

Apart from the myriad acute metabolic and systemic complications the burn patient might experience, the following complications, which deserve a special mention.

- Burn wound sepsis: Burn wound sepsis is indicated by change of the colour to black or dark brown, haemorrhage of the subeschar fat, progression of the partial thickness injury to full thickness, dirty foul smelling exudates, premature separation of eschar or appearance of eruptions. Treatment involves change of topical antibiotics, systemic antibiotics and excision of the burn wound.
- Pulmonary complications: Inhalation injury as such and other conditions like profound immunosuppression, systemic sepsis and ventilation predispose the burnt patient to pneumonia. Management includes judicious use of antibiotics, aggressive physiotherapy and respiratory care.
- Gastrointestinal complications: Hypokalaemia in the acute phase, sepsis, hypovolaemia all contribute towards ileus in the post-burn period. Management includes nasogastric suction and correction of underlying aetiology. Gastric ulceration and bleeding—curling's ulcers are also common due to impaired perfusion and the stress response. Antacids are no longer recommended for prevention as these increase gastric pH and colonisation of the stomach. Sucralfate and early enteral feeds are the strategies that are most helpful.
- Orthopaedic complications: Osteomyelitis, non-healing fractures, ulcers and heterotrophic calcification are also common.

## LONG-TERM COMPLICATIONS

### Hypertrophic Scar

It is the phase of redness and induration that is seen during the healing phase of deep second-degree and third-degree burns. Spontaneous resolution occurs in most of the cases. Pruritus associated with these scars can be managed by local application of emollients, 1% hydrocortisone ointment, local tri-aminolone injection or systemic anti-histaminics. Pressure garments also help in fast resolution.

### Contractures

Burns occurring at the flexor aspects of joints and if deep are especially prone to develop contractures during the healing phase. All scars and split skin grafts have a tendency to shrink, and this tendency is more with thin grafts. Contractures are best prevented by:

- Use of thick grafts at the joints.
- Splinting the joints for three months in a functional position after grafting (while keeping in mind that prolonged splinting may cause peri-articular fibrosis and joint capsule contractures).
- Pressure garments and silicone gel dressings provide a uniform pressure over the healing area and thus may help in prevention of contractures.
- Established contractures require surgical management:
  - Local re-arrangement of skin as single or multiple Z plasties
  - Free grafts: A thick free graft can be placed after the excision of the contractures is small. For a large

contracture a relaxing incision is given at the site of maximum tension and a free graft is placed in the resulting defect

- Flaps: Full thickness flaps that can be pedicled or mucocutaneous flaps can be utilised to release the contractures
- Tissue expanders: Can be used to expand the nearby normal full thickness skin which can then be used as a rotational flap to release the contracture.

### Rehabilitation

Burns produce a severe psychological set back in many individuals and especially in children. Their proper growth and development depends upon their psychological rehabilitation. Nurses and medical staff must be children friendly.

Social rehabilitation also has to be emphasised. They must be accepted by the society at large. Occupational therapy and rehabilitation form an integral part of burn therapy.

## BIBLIOGRAPHY

1. Advanced Life Support Group. Advanced Paediatric Life Support—The Practical Approach, 2nd edition. BMJ Publishing Group; 1997.
2. Lloyd-Thomas AR Anderson I. ABC of Major Trauma, Chapter 18. Paediatric Trauma, BMJ Publishing Group; 1996.
3. Seminars in Pediatric Surgery. In: Jay L Grosfeld (Ed.). Volume 4, Number 2 WB Saunders Company; 1995.



# Neonatal Surgery

## CONGENITAL DIAPHRAGMATIC HERNIA

It is a congenital defect in the diaphragm usually posterolateral in location through the foramen of Bochdalek through which intra-abdominal contents protrude into the thorax and may cause respiratory compromise.

The earlier the baby presents, the worse is the prognosis.

### Embryology

The defect in congenital diaphragmatic hernia (CDH) results from failure of closure of pleuroperitoneal canal at the end of embryonic period. Pulmonary hypoplasia is central to the pathophysiology of CDH. Structural abnormalities of pulmonary vasculature can result in acute pulmonary vasoconstriction. Failure of transition from the fetal to newborn circulation results in pulmonary hypertension.

### Diagnosis

The diagnosis of CDH is often made on prenatal ultrasonography and is accurate in 40–90%.

Polyhydramnios is present in 80% of pregnancies. USG diagnosis is suggested by fluid filled bowel loops in thorax, absence of stomach and other viscera in abdomen. After birth, symptoms are dependent on the degree of pulmonary hypoplasia and hypertension. Classically, these infants have scaphoid abdomen and funnel chest. The most severely affected ones present with respiratory distress at birth. The large majority present within 24 hours after birth. Diagnosis can be confirmed with plain X-ray abdomen. The location of gastric bubble can be confirmed by placement of a nasogastric tube. Rarely a contrast study may be required. About 10–20% of infants may present late with mild respiratory distress, pneumonia or gastric volvulus.

Differential diagnosis includes eventration, anterior diaphragmatic hernia of Morgagni, oesophageal hiatal hernia, cystic disease of pulmonary parenchyma and agenesis of lungs.

### Associated Anomalies

Cardiac anomalies may contribute to right to left shunt, pulmonary hypertension and circulatory instability in CDH. Hypoplastic heart and atrial septal defect are most common. Even in the absence of anatomic defects, left ventricular mass is decreased in patients with CDH. There is a significant reduction in post-ductal PO<sub>2</sub> in patients with CHD so a low post-ductal PO<sub>2</sub> should prompt a search for hidden cardiac defects.

### Treatment Options

Though the mainstay of treatment is surgery, yet the prognosis depends upon the preoperative stabilisation and degree of hypoplasia of the lung. Thus, many therapies have been explored to improve the survival.

#### *Pulmonary Vasodilators*

Numerous agents have been tried to treat pulmonary hypertension including tolazoline, prostacyclin and inhaled nitric oxide.

#### *Ventilator Strategies*

- Hyperventilation
- Permissive hypercapnia
- High frequency ventilation
- Liquid ventilation with perfluorocarbon.

#### *Extracorporeal Membrane Oxygenation in CDH*

Since the introduction of extracorporeal membrane oxygenation (ECMO) in neonatal respiratory failure, its use in CDH has increased significantly. It is offered to infants with high-risk of mortality. It can be offered before or after surgery. It can be venoarterial or venovenous. Whether ECMO really improves survival remains doubtful.

## Prognostic Factors

### Gestational Age at Diagnosis

Bulk of data suggests early prenatal diagnosis as a poor prognostic indicator. If age at diagnosis is less than 24 weeks, prognosis is uniformly bad.

### Fetal Cardiac Ventricular Disproportion

There is now abundant evidence that in addition to pulmonary hypoplasia there is also cardiac hypoplasia. The pathogenesis is postulated to be either direct effect of compression or a secondary effect of altered haemodynamics. Aortic to pulmonary artery ratio is also predictive with a significantly larger ratio in survivors.

### Lung to Head Circumference Ratio

Metkus et al. reported that the single most predictive factor was the right lung area to head circumference ratio. Survival was 100% when this ratio exceeded 1.5 and 0% when it was less than 0.6.

### Liver Herniation

The presence of left lobe of liver is a poor prognostic marker. If herniation is present survival is less than 60%. So the patients diagnosed before 24 weeks of gestation, with massive mediastinal shift, when associated with ventricular disproportion and liver herniation, have dismal prognosis. This is the population for which the best argument for foetal surgery can be made. Two techniques available are: (1) *in utero* repair and (2) *in utero* tracheal ligation.

## Surgery

Congenital diaphragmatic hernia is not a surgical emergency, and preoperative stabilisation is a prerequisite. Deferred

surgery has not in itself increased the survival rates but has helped in selecting survivors from non-survivors.

Transabdominal route is used because: (1) easier reduction of viscera through abdominal route, (2) accurate visualisation of abdominal viscera and correction of any associated intestinal anomaly is possible, (3) accurate visualisation and repair of defect possible and (4) can enlarge the abdomen by manual stretching and construction of a silo is possible. In case of a right-sided defect with only liver herniating, a thoracotomy approach could be used.

## OESOPHAGEAL ATRESIA

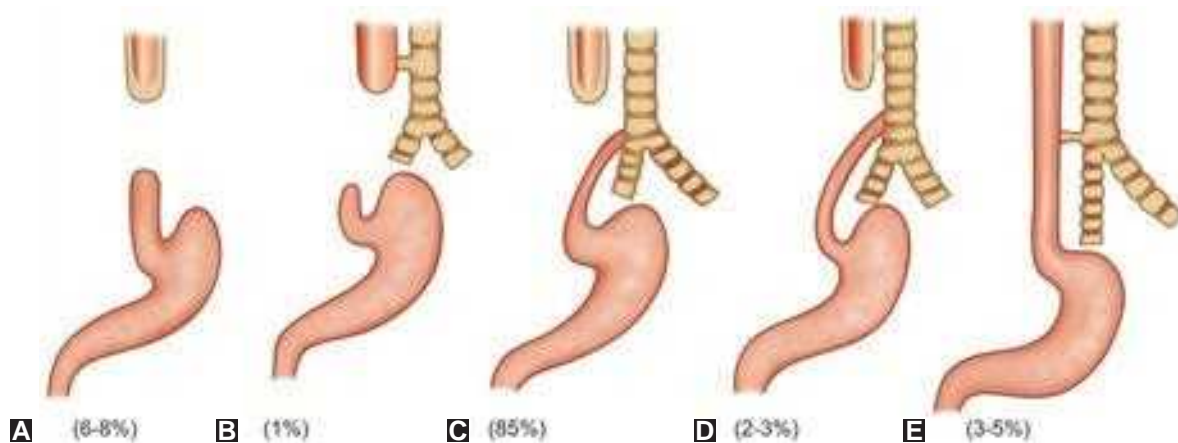
The incidence varies from 1 in 3,000 to 1 in 4,500. The improved survival of these neonates reflects the advancement in neonatal care and anaesthesia over the years. The first successful primary repair is credited to Cameron Haight in 1941.

### Embryology

The embryology of EA and TEF have been explained with the new adriamycin model. Recent studies-by-Kluth suggest that the larynx begins to develop and the trachea and oesophagus simply grow and elongate side by side after the tracheobronchial diverticulum appears. Defects or failure in the mesenchyme separating the two structures or an aberrant position of either component, may explain most of the anomalies encountered. The events leading to this malformation are likely to occur between 4 weeks and 6 weeks of foetal life.

### Anatomy and Classification

The most simple and commonly used classification is the gross classification that divides it into seven types (Figs 10.1A to E).



**Figs 10.1A to E:** Gross classification for oesophageal atresia with tracheo-oesophageal fistula

## Neonatal Surgery

1. EA without fistula (6–8%)
2. Upper oesophageal fistula with distal atresia
3. Upper pouch atresia with distal fistula (85%)
4. Upper and lower pouch fistula
5. H type (N type) tracheo-oesophageal fistula (3–5%)
6. Oesophageal stenosis
7. Membranous atresia.

Four (2, 4, 6, 7) of the above types comprise 3–5% of all these anomalies.

### Clinical Features

- At birth, oesophageal atresia should be suspected when there is excessive salivation and frothing out of mouth and nose. Episodes of cyanosis or choking may be present. If feedings are attempted, the choking and coughing will be aggravated.
- Fever, tachycardia, pallor and listlessness are late signs of pneumonitis with sepsis. With mechanical ventilation required, abdominal distension can develop rapidly, since there is free passage of air from fistula to stomach. Gastric rupture may occur particularly when obstruction of the stomach from duodenal atresia or malrotation is present. With a pure oesophageal atresia the abdomen is flat as no air can pass into stomach.
- Abdominal distension may be marked in a baby with patent distal fistula. However, the presence of a scaphoid abdomen in these neonates is strongly suggestive of a pure oesophageal atresia without a distal fistula.

### Diagnosis

#### *Antenatal*

With improved obstetrical ultrasonography, the diagnosis can often be suspected in the foetus. Polyhydramnios is present in nearly all cases of pure oesophageal atresia and 60% of cases with distal fistula. The fluid filled stomach, seen easily after 16 weeks of gestation, may appear smaller than usual or may escape visualisation, especially with pure oesophageal atresia. Polyhydramnios and nonvisualisation of the stomach, of course, may also occur in conditions such as diaphragmatic hernia, facial cleft and others.

#### *Postnatal*

- An infant with excessive oropharyngeal mucus, choking spell, recurrent cough and dyspnea must have a chest X-ray at the earliest. The best examination is the ‘babygram’—a radiograph of the whole body that includes the neck, chest, abdomen and pelvis. Just before the X-ray is taken, the mucus should be aspirated and air insufflated through the red rubber catheter. The upper

pouch is then easily seen. The upper oesophageal pouch is sometimes better seen on lateral chest radiograph.

- The presence or absence of gas in the abdomen is an important finding. If no gas is seen, and an oesophageal obstruction has been confirmed by catheter, the diagnosis of pure oesophageal atresia can be confidently made, although rarely the distal fistula may be occluded.
- The plain film is also examined for the presence of vertebral anomalies; right-sided aortic arch and signs of other anomalies like duodenal atresia and cardiac defect.
- The passage of a firm catheter (at least 8 French) through the mouth or nose into the oesophagus confirms the diagnosis. The catheter usually blocks at about 10 cm from the alveolar margins.
- Echocardiography is further recommended preoperatively to identify cardiac anomalies, which are present in 20–30% of the patients.

### Associated Anomalies

They involve nearly every part of the body. Cardiovascular, musculoskeletal, gastrointestinal and genitourinary defects are most common. VSD, PDA and right aortic arch are most common of cardiovascular lesions. Imperforate anus, malrotation and duodenal atresia are the lethal anomalies of the gastrointestinal system. Among the genitourinary; hydronephrosis, renal agenesis, uterine or vaginal anomalies are most common.

Combination of anomalies is frequent and form various syndrome. These are VATER (or VACTRL) association, seen in roughly 10% of the cases. The eponym stands for vertebral defects, anorectal malformation cardiovascular anomalies, tracheo-oesophageal, renal and limb malformations. The CHARGE syndrome is much less common and has a more guarded prognosis.

### Management

In the past many surgeons used the classification proposed by Waterston to establish treatment plan. Advances in neonatal care have affected the prognostic usefulness of the Waterston classification.

#### ***Preoperative Management***

The surgical repair of EA is not an emergency and it is far important to stabilise the neonate and complete preoperative evaluation before taking up the baby for surgery. The preoperative care involves:

- Continuous or intermittent upper pouch low pressure suctioning. A Replogle sump catheter is placed in upper pouch and connected to low pressure (< 5 mmHg) suction to avoid “Gas-steal”.

- The neonate is to be nursed in prone or lateral head up position.
- Hypothermia is avoided using overhead warmer and keeping the handling of the baby to minimum.
- The respiratory rate and saturation are monitored with blood gas parameters to assess the need for supplemental oxygen or ventilation.
- Good intravenous access is established for intravenous fluids and antibiotics. Babies with pneumonia or sepsis may require 24–48 hours of antibiotics, chest physiotherapy and ventilation.

### Operative Technique

The infant is placed in standard right posterolateral thoracotomy position. A subscapular muscle cutting incision is used.

- Thorax is entered through 4th intercostals space
- The extrapleural dissection is done
- Azygous vein is divided between ligatures for better exposure.
- Lower pouch is identified and looked up
- The fistula is ligated and divided. The closure is checked for air leak. The upper pouch is identified with the help of the anaesthetist pushing down on a preoperatively placed tube in upper pouch. After adequate mobilisation, a single layer, interrupted end-to-end anastomosis is done. The anastomosis is completed after passing a # 5 feeding tube through the nose across the anastomosis into the stomach.

### Postoperative Care

The baby is shifted to ICU after extubation or with the tube *in situ* of elective ventilation is planned. With the anastomosis under severe lesion elective ventilation with paralysis and neck flexion may be of benefit. Tube feeds can be started 24–48 hours postoperatively with concomitant use of H<sub>2</sub> blockers and prokinetic agents. The postoperative dye study is carried out around one week following the repair to assess the anastomotic site for narrowing or leak and confirm the patency of distal oesophagus. Feeds are started gradually after the dye study and progress slowly due to poor swallowing and sucking reflexes. The chest tube is removed and antibiotic discontinued. In the presence of leak the transanastomotic tube and drain is kept for 7–10 days and a repeat dye study is done to confirm spontaneous closure of leak.

### Complications

#### Early

- Anastomotic leak (5–50%)
  - Incidental—small radiological leak, no symptoms
  - Minor—saliva in chest tube but clinically well

- Major—mediastinitis, abscess, empyema, tension pneumothorax
- Anastomotic stricture 30%
- Recurrent fistula (3–5%)
- Swallowing incoordination: Aspiration.

#### Delayed

- Tracheomalacia
- Gastro-oesophageal reflux (GOR) (50–70%)
- Motility disorder
- Asthma, bronchitis
- Scoliosis, chest wall deformities (Late).

### Pure Oesophageal Atresia/Long Gap Atresia

There is no precise definition of 'long gap' atresia and the term is applied when the two ends of oesophagus cannot be brought together with ease despite adequate mobilisation. Some authors consider a gap of greater than 2 vertebral bodies as long gap and greater than 6 vertebral body as ultra-long gap atresia.

- At the initial procedure
  - Anastomosis under tension with or without elective paralysis/ventilation
  - Tension relieving techniques—myotomy (single, multiple, spiral)
  - Flap technique
  - Suture fistula technique
- Delayed primary anastomosis (6–12 weeks)
  - With bougenage—proximal, proximal and distal, electromagnetic
  - Oesophageal lengthening techniques—flaps, myotomy, lesser curve elongation (Scharli)
  - Foker's technique to bring both ends together with sutures
  - Kimura's technique—serial extra-thoracic lengthening of upper pouch
- Transmediastinal thread
  - With or without thread
  - Kato method
- Oesophageal replacement in newborns
  - Gastric transposition
- Diversion and later replacement.

### Prognosis and Long-Term Outcome

The decline in mortality associated with oesophageal atresia is the major success story in the annals of paediatric surgery. The factors contributing to early mortality include those related to surgery, late presentation and inadequate transport, problems of prematurity and associated anomalies. Mortality after discharge from hospital is less common but in the first year of life may be related to congenital heart disease, recurrent pneumonia, tracheomalacia or gastro-oesophageal reflux related sudden infant death syndrome (SIDS).

## INFANTILE HYPERTROPHIC PYLORIC STENOSIS

Infantile hypertrophic pyloric stenosis (IHPS) is a common cause of gastric outlet obstruction in infants. The prevalence of IHPS ranges from 1.5 to 4.0 in 1,000 live births among whites but is less prevalent in African-Americans and Asians. It is more common in males with a male:female ratio of 2:1 to 5:1.

Although obstructing pyloric muscular hypertrophy is occasionally found in still borns, cases have been reported with intrauterine gastric distension associated with pyloric hypertrophy. This disorder generally evolves during the first postnatal week and become clinically significant only after 2–4 or more weeks of life. For these reasons the entity should be considered acquired rather than congenital.

### Anatomy and Aetiology

The appearance of the pylorus in IHPS is that of enlarged muscle mass measuring 2–2.5 cm in length and 1–1.5 cm in diameter. Histologically the mucosa and adventitia are normal. There is marked muscle hypertrophy primarily involving the circular layer, which produces partial or complete luminal occlusion.

There is genetic predisposition to the development of IHPS. In addition to the variability among races and clear male preponderance, there is an increased risk to the first born infants with a positive family history and certain ABO blood types, elevated gastrin levels, higher concentrations of neurotransmitter substance P and a decrease in nerve supporting cells in muscle layers have all been implicated in pylorospasm and muscle hypertrophy.

### Clinical Presentation

The cardinal symptom is vomiting after 3–4 weeks of age. The initial emesis is mild but within one to several days, it increases in its frequency, its amount and its forcefulness until typical projectile vomiting has developed. Affected babies are usually vigorous and not obviously dehydrated. Although they remain hungry they begin to refuse breast or the bottle feeds as the stenosis becomes more severe. They continue to urinate until late in the course of disorder, but the stools are usually diminished in their number and amount.

About 20% of the infants begin to vomit shortly after birth. A second group has an abrupt onset of vomiting after the first week or two of life. The “Classical” history is that of increasing emesis at 2–4 weeks of age, in a first born male, seen in less than 20% of the cases.

Haematemesis is a symptom of variable frequency. The bleeding is oesophageal in origin due to erythema and friability of the distal one-third of the oesophagus.

Gastritis with gastric ulceration can occur late in the disease due to distension and stasis.

Jaundice is seen in a significant number of babies and is associated with depression of the enzyme hepatic gluconyl transferase.

### Diagnosis

Non-bilious projectile vomiting, visible gastric peristalsis and hypochloreaemic hypokalemic metabolic alkalosis are cardinal features of IHPS. A definitive diagnosis can be made in 75% of the infants with IHPS by careful physical examination alone but this is becoming more of a lost skill. Frequently, imaging procedures are requested in lieu of careful physical examination. To be successful in palpating the pyloric olive, the infant must be calm and cooperative. The examiner should be ready to commit 5–15 minutes for proper examination. Examination with a pacifier or just after feeds could be more successful.

Ultrasonography is the most common imaging technique for the diagnosis. The commonly used criteria on ultrasonography include a pyloric muscle thickness of 4 mm and a pyloric channel length of 16 mm or more.

A barium upper gastrointestinal examination is highly effective in making the diagnosis. An elongated pyloric channel and two indentations at the distal end of antrum are suggestive of IHPS (Fig. 10.2).

### Laboratory Studies

The classical findings in advanced pyloric stenosis are a raised haematocrit, an increased urinary specific gravity



Fig. 10.2: Upper gastrointestinal tract contrast study in hypertrophic pyloric stenosis

and severe hypochloaemic alkalosis. In severely depleted infants, the hepatic glycogen content is markedly reduced and serum glucose levels are precarious.

### Differential Diagnosis

Medical conditions, which can be responsible for repeated emesis in small babies, include subdural haematoma, meningitis, adrenal insufficiency, milk intolerance hepatic enzyme defects and other inborn errors of metabolism. Surgical causes include other causes of gastric outlet obstruction.

### Initial Management

Most of the babies are severely depleted and must be treated vigorously. It is not essential that the pyloric obstruction be relieved immediately. The slow replacement of potassium chloride and sodium and the replenishment of glycogen and protein in the liver and muscles may require several days. A nasogastric tube should not be placed routinely because it removes additional fluid and hydrochloric acid from the stomach. The electrolyte replacement is based upon the well-known loss of  $K^+$  as compared to the  $Na^+$ . An associated decrease in  $K^+$  in both the intracellular and vascular compartments will lead to the paradoxical renal excretion of the acid urine in the face of serum alkalosis. This is because ammonium and hydrogen ions are substituted for sodium and potassium in the urine when these are seriously depleted.

The preoperative fluid treatment of infants with pyloric stenosis requires maintenance fluids plus replacement of the estimated losses. Intravenous fluid resuscitation with 5% dextrose in 0.45 normal saline containing 20–40 mEq/L of KCl is the optimal solution for fluid and electrolyte replacement.

### Surgical Treatment

The key to successful operation is the extramucosal operation of the pyloric muscle from near the pyloroduodenal junction well onto the normal stomach.

### Classical Pyloromyotomy (Ramstedt Operation)

The serosa on the anterior wall of the hypertrophied pylorus is incised with a scalpel from just proximal of the pyloric vein to the antrum just proximal to the area of the hypertrophied muscle.

Perforation during pyloromyotomy should be a rare event. If this occurs the submucosa should be approximated and a portion of omentum placed over the site. The pylorus should be rotated 180° and a myotomy done on posterior wall. Laparoscopy has also been described and is becoming more and more popular.

### Postoperative Management

Most infants can be started on oral feeds 6–8 hours after surgery. If the duodenum has been entered and has been repaired, feeds are withheld for 24–36 hours. Vomiting occurs to some degree in 50–80% of babies after surgery. This is due to narrowing and oedema of the pyloric canal. The main cause of vomiting, however, is GOR. A failed myotomy is very rare. No infant should be considered for re-operation until 2 or 3 weeks have passed.

### MALROTATION

Anomalies of intestinal differentiation rotation and fixation are common, occurring in 1:200 to 1:500 live births. Although newborns and small infants are more likely to present symptoms from these anomalies, chronic abdominal problems or acute bowel obstruction resulting from malrotation are also seen in older children, adolescents and adults. The symptoms are often deceptive and the findings at operation confusing, unless the surgeon has a clear understanding of the embryology.

### Embryology

Normal rotation and fixation may be described according to the way in which it affects the two ends of intestinal tract, the proximal duodenojejunal loop and the distal cecocolic loop. The intestinal development can be divided into eight stages.

1. Formation of straight intestinal tube
2. Formation of body stalk (umbilicus)
3. Progression of duodenum into mesenchyme beneath intestine vessels
4. Withdrawal of jejunum and ileum (pre-ductal) intestine into abdomen on right pressing colon to left side
5. Withdrawal of terminal ileum and caecum to subpyloric area
6. Growth of abdomen, with ascent of liver and growth of ascending colon
7. Migration of caecum and ascending colon to right gutter
8. Fixation of mesenteries—ascending, descending colon and small bowel.

### Malrotation in a Newborn

Persistent vomiting is the regular symptom. If emesis is due to rotational anomaly bile is almost always present. Diarrhoea with blood streaking or even frank haemorrhage, may occur as a result of mesenteric vascular congestion depending upon the time the vessels have been occluded. Abdominal distension and tenderness, toxicity and increasing pallor and cyanosis are progressive manifestations of sepsis gangrene of bowel.

## Malrotation in Older Infants and Children

After early infancy, malrotation is more likely to present with irritability, recurrent abdominal pain, nausea, bilious vomiting and periodic abdominal distension. Small children manifest with failure to thrive from malabsorption due to longstanding lymphatic and vascular obstruction while other children develop chylous ascites. Large foul, fat containing stools are also characteristic of malabsorption.

Catastrophic volvulus is possible at any time of life. Young adults with unusual types of malrotation present with right lower quadrant pain, fever, tenderness and leucocytosis.

## Diagnosis

### Laboratory Studies

The usual laboratory studies are normal until prolonged vomiting or bowel ischaemia occurs. Children with volvulus develop haemoconcentration, high urinary specific gravity and leucocytosis. Since bacterial infection should always be anticipated. Therefore, blood and urine cultures should be obtained before any operative procedure. Jaundice occurs readily and hyperbilirubinaemia is usually present.

### Radiologic Studies

X-ray of abdomen is of utmost importance in a study of any baby with bilious vomiting.

Plain X-rays can usually differentiate between high, middle and low intestinal obstruction. In malrotation the duodenum is partially or completely occluded, the stomach and duodenum are distended, and only small amounts of gas or contrast material are seen in the lower duodenum.

Examination of upper intestinal tract with contrast study is also important. In the usual case of malrotation the stomach and duodenum are found to be excessively distended. Some contrast may pass into jejunum but very little is seen in lower bowel. To exclude malrotation conclusively the duodenojejunal junction must be located to the left of spine at the level of the duodenal bulb in a position half way between the lesser and greater curvature of the stomach.

Ultrasonography has become very useful in detecting malrotation with midgut volvulus with a whirlpool flow pattern in the superior mesenteric vein and mesentery around a superior mesenteric artery; best seen on colour Doppler.

## Treatment

Radiologically identified rotational anomalies (mixed) are known to produce serious sequel in 40–50% of cases. For this reason, these should be corrected whenever their presence is confirmed. The base of mesentery should be widened to avoid recurrence.

## Preoperative

If malrotation has been identified by radiological analysis the determination must be made as to whether or not immediate operation is necessary. When there is simple obstruction, but no evidence of ischaemia, nutritional evaluation and measures to improve the general state of infant should be undertaken prior to surgical exploration.

With volvulus the transvascular losses are accelerated. If the fluid losses have not been replaced and general circulation is already inadequate due to hypovolemia, severe hypotension may result intraoperatively. If there is any question of volvulus, rapid resuscitation and operative correction must be done expeditiously. Operations for malrotation often lead to shock due to unrecognised severe hypovolemia. A moderate degree of overhydration and a modest increase in normal expected blood volume are safety factors, which should not be neglected.

## Surgical Technique

It is now agreed that Ladd's operation is the best treatment of almost all forms of malrotation. The temptation to fix the bowel in normal position with the caecum in the right lower quadrant and small bowel on its left side should be resisted. Ladd's procedure consists of following steps, which should be carried out in proper sequence.

1. Evisceration of the midgut and inspection of mesenteric root
2. Counterclockwise derotation of midgut volvulus
3. Lysis of Ladd's peritoneal bands with straightening of duodenum along the right paracolic gutter
4. Appendectomy widening the base of mesentery
5. Placement of caecum in left upper quadrant.

When the intestine appears viable, simple Ladd's procedure suffice. A localised gangrenous segment, with ample remaining bowel, may be resected and primary anastomosis done.

A simple enterotomy is preferred when the bowel remains obviously ischaemic at ends or with areas of marginal viability. Second look surgery is usually performed when there are multiple areas of questionable viability or when entire midgut appears non-viable.

## Postoperative Care

Majority of infants can be expected to experience early return of gastrointestinal function. If there has been severe congestive ischaemia, feedings should be withheld for 1–2 weeks. The antibiotics should continue for 7–10 days in an effort to eliminate bacteria, which may be sequestered in lymphatics.

## Long-Term Results

- Most authors report permanent cure of infants and children after operation
- There may be pattern of abdominal pain in few children after Ladd's procedure. Although recurrent volvulus is unusual continued venous and lymphatic obstruction can certainly occur.

## HIRSCHSPRUNG'S DISEASE

Hirschsprung's disease is characterised by an absence of ganglion cells in the intermuscular (Auerbach's) and submucosal (Meissner's) plexuses of the intestine usually the large intestine starting distally from anorectum proximally, to a varying distance, leading to constipation.

The aetiology is unknown. The enteric ganglion cells migrate from the neural crest, along the course of the vagus nerves, to the intestine. The rectum is innervated by the 12th week of gestation. The passive migration and neuronal differentiation appears to depend on the intercellular matrix.

The conventional theory is that migration is incomplete. Failure of ganglion cell precursors to differentiate and mature would result in similar findings. The distal aganglionic bowel remains tonically contracted and does not exhibit normal peristalsis.

At present two genes have been implicated in strongly increasing the susceptibility to Hirschsprung's disease, and doubtless others will come to light in the near future. The RET gene encodes a tyrosine kinase transmembrane receptor whose ligand is a neurotrophic factor. The manner in which the gene abnormality contributes to aganglionosis is unclear. Mutations of the RET proto-oncogene have been found in 50% of those with familial Hirschsprung's disease but were not related to the length of the aganglionic segment. The second gene, which has been implicated, is termed the endothelin-B receptor gene (EDNRB). This gene has been localised to chromosome 13q22.

The incidence of Hirschsprung's disease is 1 in 4,500 to 1 in 5,000. The male/female ratio is about 4:1, but this disparity diminishes to 1.5–2:1 with total colonic disease.

Associated anomalies include urological anomalies (2.2%), anorectal malformations and colonic atresia (4.5%), small bowel atresia (1%), deafness (2.2%) and cardiovascular anomalies (5.6%). Also included was Down's syndrome (2.8%).

An absence of ganglion cells in the intermuscular (Auerbach's) and submucosal (Meissner's) plexuses is the hallmark of Hirschsprung's disease. Thickened nerve trunks are seen in the intermuscular plane and in the submucosa. The length of the aganglionic segment varies.

The junction between ganglionic and aganglionic bowel is called the transition zone and usually corresponds to the area of tapering or coning between dilated and non-dilated

bowel seen on X-ray or at laparotomy. With long segment disease, however, false cones are known to occur so the gross appearance is not a reliable guide to the presence or absence of ganglion cells.

Histologically the transition zone is considered to show reduced numbers of ganglion cells and an increase in nerve fibres. The length of the transition zone varies from a few millimetres to many centimetres.

## Clinical Presentation

About 94–98% of normal full-term newborn infants will pass meconium within the first 24 hours of life. It is unusual for a normal baby not to have passed meconium by 48 hours. A history of delayed passing of meconium is considered a common feature of Hirschsprung's disease. The presence of abdominal distension is usual unless the baby has had a rectal examination or rectal washout. Bilious vomiting and poor feeding are also common.

The majority of infants who present within the neonatal period have signs of low intestinal obstruction—distension, bilious vomiting and little or no passage of stool.

Examination will reveal generalised distension, active bowel sounds and a narrow empty rectum on rectal examination. Withdrawal of the finger may be followed by passage of gas and meconium.

Plain abdominal X-ray will show many loops of distended gas filled bowel with typically, an absence of gas in the rectum. The differential diagnosis includes causes of low intestinal obstruction in addition to Hirschsprung's disease such as intestinal atresia, meconium ileus, small left colon and meconium plug syndromes.

The second type of acute presentation is with enterocolitis. X-rays show gross distension with thickened bowel wall.

The third and least common acute mode of presentation is with intestinal perforation. The risk of perforation is higher with total colonic disease; the perforation is usually in the aganglionic bowel. With short segment disease, the perforation is proximal to the aganglionic zone.

In older infants and children the history is of long standing constipation and distension, sometimes associated with failure to thrive. The clinical picture is of massive abdominal distension and marasmus and is managed with a combination of laxatives, suppositories and enemas but with only partial success.

## Types

1. Short segment or classical rectosigmoid—involving rectal and rectosigmoid. Comprises 70% cases
2. Long segment Hirschsprung's disease—involving more than the classical segment, reaches up to descending colon.



3. Subtotal Hirschsprung's disease—involves up to mid-transverse colon.
4. Total colonic aganglionosis—involves entire large colon.
5. Total intestinal aganglionosis—extending to ileum and even jejunum.
6. Ultrashort segment Hirschsprung's disease—limited to distal 2–3 cm of rectum.

### Initial Management

The management for those presenting with neonatal intestinal obstruction is the same as for any other form of obstruction—intravenous fluids, nasogastric decompression and consideration of antibiotics. If rectal examination produces gas and meconium then causes of complete mechanical obstruction, such as atresia, have been out-ruled. If no gas or meconium is produced after rectal examination then a single rectal washout with saline is performed. The aim is to establish if there is gas in the distal intestine to narrow the range of differential diagnoses. If there is no gas after the washout, a contrast enema is performed. This will show the colonic anatomy, may demonstrate the presence of a meconium plug or a small left colon, and if the contrast reaches gas filled intestine then intestinal continuity is confirmed. It is usual for children with Hirschsprung's disease to pass large amount of gas and meconium after a washout or a contrast enema and the infant's clinical condition will then improve.

If the presentation is with enterocolitis then urgent decompression is necessary. A rectal examination and rectal washouts are employed and are usually successful. Failure to decompress under these circumstances will indicate a need for surgery. If decompression is successful then surgery should be deferred until a time of greater physiological stability. All these children should receive oral vancomycin as well as broad-spectrum intravenous cover.

For those infants and children presenting with a history of constipation, the need for urgent investigation is less pressing. Recourse to enemas and washouts will alter the appearance of the bowel on a contrast enema.

### Diagnosis

There is no substitute for a tissue diagnosis. Reliance on contrast enemas or manometry is less secure and less accurate. Clinical impression needs confirmation.

Rectal suction biopsy has been proved satisfactory and reliable in the hands of expert pathologists. Regardless of the method used, the biopsies should be taken from the posterior rectal wall, at least 25 mm above the dentate line. The bowel below this level is hypoganglionic and the failure to see ganglion cells may not be pathological.

Various methods of punch biopsy obtaining biopsies have been described. Suction biopsy instruments are widely used in young infants. Rectal biopsy may be followed by complications like bleeding and perforation.

Anorectal manometry assesses the relaxation of the internal anal sphincter in response to rectal distension. A failure of the sphincter to relax, or indeed an increase in tone, is a feature of Hirschsprung's disease.

Contrast enemas are widely used, both to make the diagnosis and to establish the position of the transition zone. Not infrequently contrast enemas are requested in the presence of intestinal obstruction in newborns to more clearly define large bowel anatomy. Subsequent to the enema marked decompression may be achieved and the infant's condition improved.

When specifically looking for Hirschsprung's disease the recommendation is to use 50% dilute barium sulphate. The irregular contracted rectum and distal sigmoid colon with a transition cone into dilated proximal bowel will be seen. With standard length Hirschsprung's disease the contrast enema appearance will usually correspond with the histological findings. With long segment or total colonic disease the appearance on the enema may not be reliable and false cones are known to occur.

A delayed X-ray film taken at 24–48 hours may demonstrate retention of contrast, lending support to a diagnosis of Hirschsprung's disease. The cardinal features included a transition cone, irregular bizarre contractions of the aganglionic zone and barium retention. However, high false-positive rates of diagnosing Hirschsprung's disease by barium enema in infancy have been reported.

### Operations

- Staged (colostomy, pull-through, colostomy closure)
- Single-stage pull-through (without colostomy)
- Laparoscopic assisted pull-through.

### Treatment

Once the diagnosis has been established there are many options for treatment.

The first decision is whether or not to bring out a stoma. Many infants can be managed for a week or month by means of daily saline rectal washouts. However, some children with extensive disease will not achieve satisfactory decompression by this means. If washouts are unsatisfactory then a stoma will be necessary.

The next consideration is where to site the stoma. For many years the approach to Hirschsprung's disease was a three-stage reconstruction: (1) right transverse colostomy, (2) pull-through at 6–9 months of age and (3) colostomy closure some weeks later. Others have used a two-stage procedure: (1) fashioning the stoma above the transition zone and (2) then using the stoma as the apex of the pull-through. In many cases, a single-stage reconstruction is safe and effective.

Single-stage procedures can only be accomplished if reliable frozen section histology is available.

In attempting to define the length of the aganglionic bowel, biopsies may be sent from the apex of the sigmoid colon, distal descending colon, splenic or hepatic flexures and appendix of terminal ileum.

Three pull-through operations and their variants are in common use throughout the world and will be described here. These are the Swenson, Duhamel and Soave procedures. All are modified from the original descriptions but in each case the original concept is valid.

The Swenson operation entails dissection of the rectum from its attachments in a plane on the rectal muscle wall. The dissection may be commenced on the wall of the distal sigmoid or upper rectum. The dissection advances distally, dissecting the full circumference of the rectum. Deep in the pelvis it is important to remain close to the rectum on its anterior aspect. When the dissection has reached to within 2 cm of the dentate line anteriorly and 1 cm posteriorly this phase is complete. The distal extent of the dissection is judged by inserting a finger in the anus. At this stage, the bowel is divided at the level chosen for the pull-through and the two ends sutured closed.

The anal phase of the dissection then commences. The apex of the dissected rectum is drawn out through the anus, everting the rectum. If the dissection has been adequate the anus may be partially everted. An incision is made from 9 to 3 o'clock anteriorly through the rectal wall, 1–2 cm above the dentate line. Only the bottom of the dentate line can be identified with certainty and this is the point from where measurements are made. Through this opening in the rectum the ganglionic colon is pull-through with care to avoid torsion. The colon is opened at its apex and sutured full thickness to the cut edge of anorectum with interrupted absorbable 4/0 sutures.

The incision of the rectum is then completed in stages, as is the anastomosis.

Posteriorly in the 6 o'clock position the suture line should be about 1 cm from the dentate line. The rectum is now free and should be sent for histological examination.

The commencement of the Duhamel procedure is identical. The early phase of rectal dissection is also the same. The dissection proceeds circumferentially until within 3–4 cm of the dentate line. This level is well below the pelvic peritoneum.

The anal phase then commences. It is best to partially evert the anus for this phase. This is easily accomplished by using tissue forceps at the 3 and 9 o'clock positions. An incision is then made along the dentate line from 4 to 8 o'clock and a retrorectal tunnel developed initially with scissors and then with a long clamp. This tunnel should quickly reach the level of the abdominal dissection. The tunnel is then widened to accommodate the pull-through bowel.

The previously divided and sutured bowel is then pulled through with care to avoid torsion. The open end is sutured to the anal incision with interrupted absorbable 4/0 sutures. Finally, the double wall between rectum and colon is stapled and divided with a linear stapler. Alternatively, a crushing clamp can be left attached.

Within the abdomen, the open end of rectum is then closed with a running extramucosal 4/0 suture.

For the Soave's procedure, the principal is to keep a muscular cuff of rectum without the mucosa through which the ganglionic bowel is pulled through. From the abdominal side, at the level of the white line of peritoneum, the muscle coat is divided with scissors circumferentially to enter the submucosal plane. This plane is then dissected with gauze pledgets or with artery forceps. The dissection is easier in young infants. The submucosal dissection progresses distally to a level about 1 cm above the dentate line and the mucosal tube is then everted.

Once the dissection has been completed the mucosal tube is divided 1–2 cm above the dentate line and the ganglionic bowel is pulled through and sutured at this level. There seems little reason to perform the original Soave's operation which left the pull-through bowel outside the anus and most now perform the Boley modification. The catheter is usually removed after 24 hours and enteral feeding resumed once intestinal function is established.

In the presence of a defunctioning stoma a contrast study should be performed after 2 weeks. If the appearances are satisfactory the stoma may then be closed.

## Complications

Surgery for Hirschsprung's disease is associated with all the usual complications that may follow major intestinal surgery. These include leakage, wound infection, dehiscence and postoperative bleeding. The early mortality was 3.3%.

Long-term complications include varying degrees of faecal incontinence, recurrent enterocolitis intractable strictures and fistulae.

## ANORECTAL MALFORMATIONS

Anorectal malformations account for the most common congenital anomalies dealt by paediatric surgeons all over the world. To understand the present treatment options of the varied forms of this anomaly, it would be interesting to briefly go through the historical developments of the treatment options for anorectal malformations.

Although the absence of a normal anus was recognised by the Greek, Romans and Arabic physicians in ancient history, it was in the seventh century that Paulus Aeginata described a method of treatment by passing a bistoury through the

perineum followed by dilatation with bougies. In 1710, the use of colostomy was described for these malformations.

Denis Browne described these malformations as high and low depending on whether the gut ended above or below the levator ani.

The aim of management is now from saving life to ensuring a normal quality of life. Management is now based on accurate scientific information and the surgery is performed by trained paediatric surgeons.

### Embryology

The anus, lower rectum and urogenital system become differentiated between 5 and 8 weeks of embryonic life.

The allantoic duct is in communication with the hindgut in a cavity known as cloaca, closed to the exterior by the cloacal membrane.

This cavity is divided by the urorectal septum into urogenital tract anteriorly and posteriorly by two processes. First there is the Torneaux's septum which stops its downgrowth at the level of the verumontanum or the mullerian tubercle. It is here that most rectourethral fistulae occur in the male. Below this point, the urorectal septum consists of an ingrowth of mesenchyme from a lateral direction that fuses in the midline. This is called Rathke's fold.

An ingrowth of mesoderm divides the cloacal membrane into the urogenital membrane ventrally and the anal membrane dorsally. The perineum is formed by a continued ingrowth of this mesoderm between the two membranes.

The urogenital portion acquires an external opening by the 7th week.

The anus develops by an external invagination, the proctodeum, which deepens to the rectum but is separated from it by the anal membrane. At the 8th week, the anus acquires an external opening by the rupture of the membrane.

In the female, the mullerian ducts which form the uterus and vagina descend in the urorectal fold long after the portioning of the cloaca by the urogenital septum so that the rectal fistulous connections usually occur in the vagina and not in the bladder or urethra as in the male. If the portioning fails to occur in the female, the mullerian ducts relentlessly descend on the undivided cloaca and carry through to the perineum. Thus, the rectum is carried along with the descent of the mullerian ducts to arrive at or very near the perineum.

The external sphincter muscle is derived from the regional mesoderm (although sphincter muscle fibres are present in all cases, there may be a good deal of variation in the size of the muscle bundle).

The puborectalis plays a key role in maintaining the angle between the anal canal and rectum and hence is essential for preservation of continence.

### Incidence and Aetiology

The worldwide incidence of the anomaly is 1:5,000 live births. The anomaly is more common among male infants (55–65%).

The exact cause is still unknown but these malformations are thought to be the result of arrests or abnormalities in the embryological development of the anus, rectum and urogenital tract.

Genetic predisposition has been seen rarely in some families. Sex-linked and autosomal dominant inheritances have been suggested. Apparently there is no racial predilection.

### Classification

Krickenbeck International classification has been outlined in Table 10.1.

**Table 10.1:** International classification (Krickenbeck, 2005)

Major clinical groups	Rare/regional variants
Perineal (cutaneous) fistula	Pouch colon
Rectourethral fistula	Rectal atresia/stenosis
–Prostatic	Rectovaginal fistula
–Bulbar	H-fistula
Rectovesical fistula	Others
Vestibular fistula	
Cloaca	
No fistula	
Anal stenosis	

### Clinical Presentation

#### Local Examination

The anomaly is usually characterised by the absence of anal opening at its normal site though a varied spectrum of anomalies is seen depending upon the extent of anorectal agenesis and the presence or absence of associated genitourinary fistula (Fig. 10.3).

The key to successful clinical diagnosis in case of anorectal malformation is very careful examination, which may need to be repeated in babies seen only few hours after birth as it takes 12–18 hours for swallowed air to reach the terminal part of the colon.

The following tell tale signs should be looked for:

- Gross abdominal distension after 24 hours of life may be seen in a patient without fistulous communication or with a tiny fistulous communication with the genitourinary tract



**Fig. 10.3:** Absent anal opening in a case of anorectal malformation

- Abdominal distension with redness over the abdomen in a sick baby could be due to perforation peritonitis in delayed presentations after 36 hours
- Meconium stain over the thighs is usually seen if carefully looked for in a case with fistulous communication
- Frank meconurea is seen in a case of large fistulous communication with the bladder, as in cases of congenital pouch colon associated with anorectal agenesis.
- The anocutaneous reflex needs to be elicited
- The perineum needs to be examined for presence of sacral agenesis which is usually associated with high anorectal anomaly, gluteal muscles and most importantly the bulge at the site of normal anal opening seen and felt on making the baby cry
- Associated urethral anomalies in males like megalourethra, hypospadias, urethral duplication and congenital urethral fistula need to be identified.

### Perineum

The perineum in a normal neonate is convex and broad, the anal opening is placed centrally within the sphincter complex and in males the median raphe is very faint.

In rectal atresia, the perineum is normal appearing.

In low anomalies in males, the perineum is convex and broad but the median anogenital raphe is hypertrophied across the perineum and scrotum. Meconium bleb may be seen at the site of fistula and the anocutaneous tract may be seen filled with meconium.

In high anomalies in males, the perineum is short or inconspicuous and the scrotum is in close proximity to the anal pit. The anal pit is covered by heaped up dermal

mound of variegated appearance. The median anogenital raphe beyond the anal pit across the perineum is uniformly faint.

### Visible Abnormal Anal Opening

If there is a visible opening in the perineum near the normal site of anus, it has to be examined in detail carefully.

*Anal stenosis:* The anal opening may be small and at the normal anal site. It may be covered by a bridge of skin resembling a bucket handle. Bowel of normal calibre is generally found close to the surface, but occasionally it may be higher up with a long narrow tract when named it is called anorectal stenosis.

*Ectopic anus:* The anal opening may be sited anteriorly. In boys, it is generally found between the normal anal site and the posterior limit of the scrotum, but may extend anteriorly on the penile shaft. Rarely the anus may be located posteriorly in the midline. It may be in the midline or slightly deviated.

*Anocutaneous fistula:* The anal opening may be ectopic and stenotic and a meconium filled tract may be seen in the midline behind it. The meconium may be milked out on applying pressure over the tract. On passing a bougie, it is felt almost horizontally backwards and bowel of normal calibre is usually found fairly close to the surface.

*Rectoperineal fistula:* The bougie in the visible opening passes more vertically and bowel of normal calibre is higher up.

In girls, the opening may be in the perineum, but is more commonly seen in the vestibule. The anatomy can be recognised in the same manner with the help of a bougie after identifying three separate openings in the vestibule.

- *Anovestibular fistula:* The opening is in the vestibule and on passing a metallic bougie, it takes a posterior route towards the normal anal site and it can be felt percutaneously.
- *Rectovestibular fistula:* The opening is in the vestibule and on passing a metallic bougie, it takes a cranial route towards the vagina and it cannot be felt percutaneously.
- *Vulval anus:* It is lined by mucosa anteriorly and by skin posteriorly.

However, there are shades of grey between the classical types in both sexes. Clinically, if the baby is symptomatic with straining at stools or remains constipated, the opening is inadequate and possibly a fistula exists requiring a preliminary colostomy.

### No Visible Anal Opening

In boys, the passage of meconium through the urethra may sometimes be noted. The bowel commonly terminates in either the prostatic or the bulbar urethra, but it may terminate

blindly or at the bladder base. Thus, the anomaly in males may be:

- ARM with rectoprostatic urethral fistula
- ARM with rectobulbar urethral fistula
- ARM with bladder neck fistula
- ARM without fistulous connection.

In girls, meconium may be seen emerging from the orifice of the vagina or of a common urethrovaginal canal or cloaca. The level of the terminal bowel can be established by ultrasonography, invertogram, CT scan and MRI scan as described above or by a lateral vaginogram or a cloacogram if there is a large fistula.

The anatomy of the pelvic organs of girls who have normal urethral and vaginal orifices is relatively easy to unravel, but if there is a common urethrovaginal canal, the anatomy can be bizarre.

If there are two openings in the vestibule the lesion may be:

- Rectovaginal fistula which may be high or low
- Anorectal agenesis without fistula
- Anal agenesis without fistula.

If there is one opening in the vestibule the lesion may be rectocloacal fistula which may be high or low.

As mentioned earlier there may in both sexes be shades of grey between the classical types.

### Rectal Atresia

A normal anal opening without continuity with the bowel above.

### Systemic Examination

Complete physical examination, including passage of a nasogastric tube to rule out an esophageal atresia should be done in all cases.

The abdomen should be examined for any palpable enlargement of the kidneys or bladder, other associated congenital anomalies like major cardiac malformations, major vertebral and craniocerebral defects and Down's syndrome.

It is possible today to exclude or confirm the presence of all these malformations in a reasonably short time by a careful clinical examination, ultrasonography including echocardiography, plain skiagram of the chest, abdomen and spine.

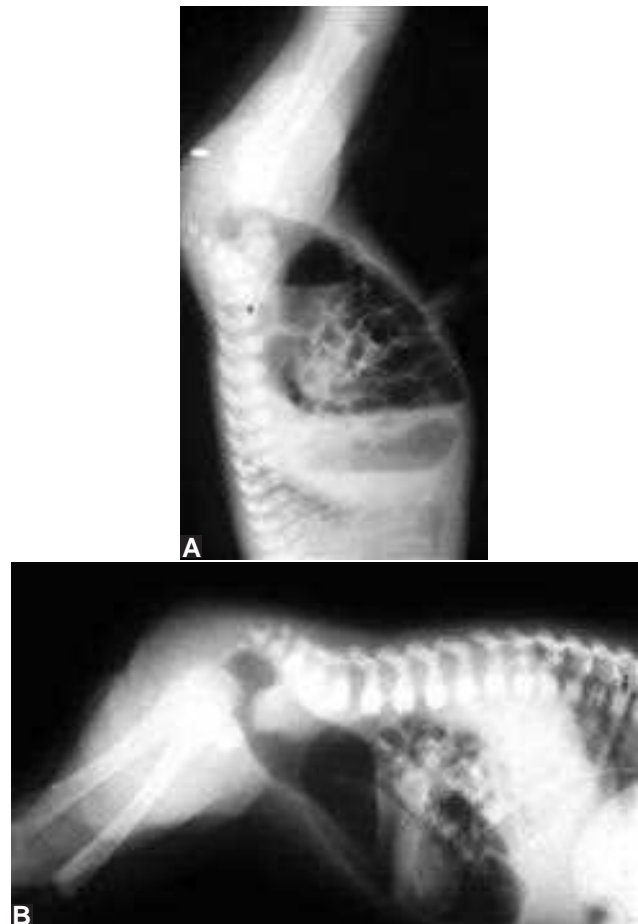
Associated anomalies which need to be identified before the baby is discharged include:

- Obstructive uropathies and severe vesicoureteric reflux
- Ambiguous external genitalia and deformities of male and female genitalia
- Other renal, limb and ocular anomalies.

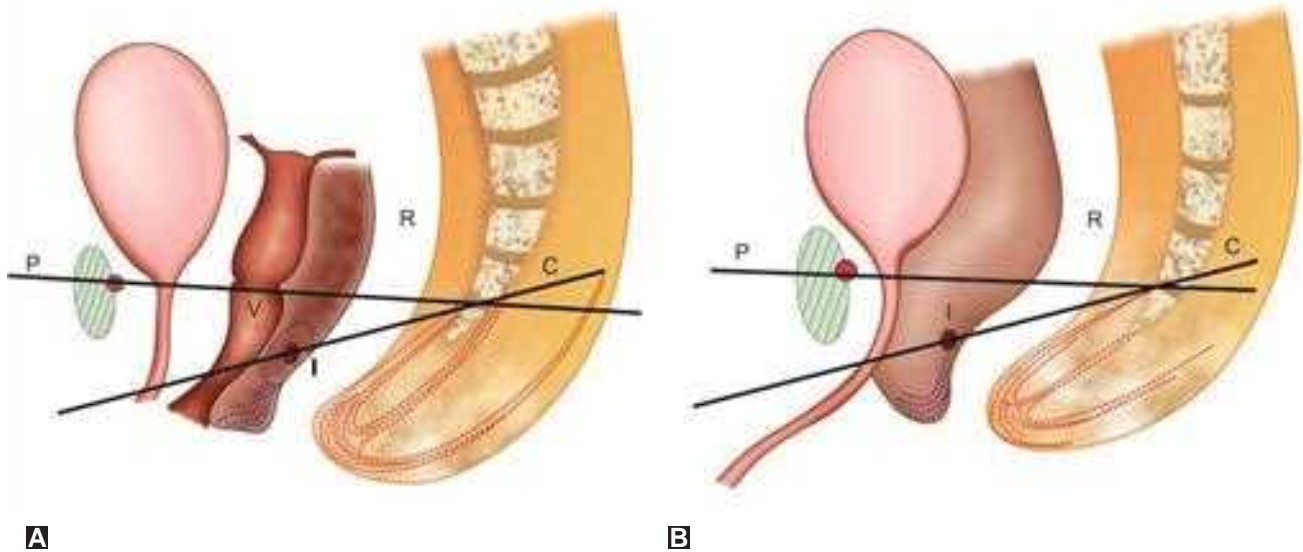
### Investigations

The gold standard Wangenstein and Rice invertogram whether done in the standard head down position or the prone cross table lateral position is still the most widely used investigation of choice (Figs 10.4A and B). It is reliable only after at least 18–20 hours after birth as it takes this much time for the swallowed gas to reach the lower rectal pouch. Once filled with air or contrast, the blind rectal pouch is located in relation to the pubococcygeal line or the I-point of ischium. If the sacrum is poorly developed, the P-C line may be determined by commencing from the midpoint of the pubis anteriorly and transecting the junction of the upper and lower three-quarters of ischium (Figs 10.5A and B).

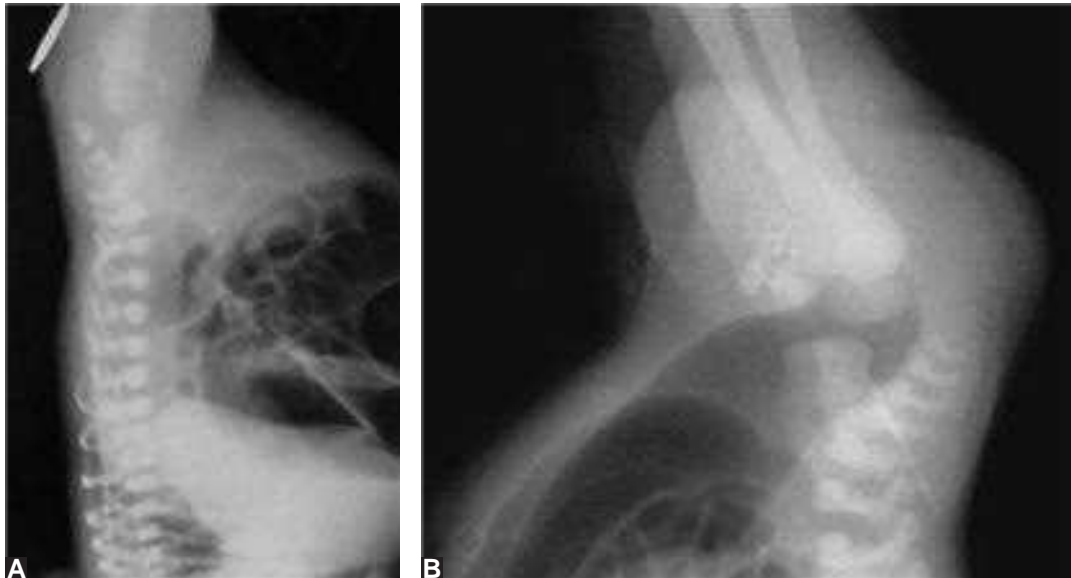
Supralelevator lesions are identified when the blind rectal pouch ends above the P-C line (Fig. 10.6A). The bowel in intermediate lesions extends to a line drawn through the most inferior portion of the ischium, parallel to the P-C line (Fig. 10.6B).



**Figs 10.4A and B:** (A) Invertogram showing an anorectal malformation. Note marker at the anal pit; (B) Cross table lateral invertogram showing an anorectal malformation



**Figs 10.5A and B:** A line diagram showing the conventional understanding of the pelvic anatomy in (A) Female; (B) Male, showing relationship of P-C and P-I lines



**Figs 10.6A and B:** Invertogram: (A) A high anorectal anomaly above P-C line; (B) An intermediate anorectal anomaly between P-C and P-I lines

A gap of greater than or equal to 1 cm between gas shadow and skin usually represents a high anomaly (a gap < 5 mm usually represents a low lesion).

The level of the terminal bowel can also be determined by ultrasonography. The relation of the terminal bowel to the sacrum, the urogenital organs and the surface can thus be visualised.

A lateral X-ray taken after instillation of radio-opaque dye through a catheter in the urethra will delineate the terminal bowel, if there is a relatively large urethral fistula. Voiding cystogram may be obtained to demonstrate a fistula, ureteral

reflux, urethral stricture or connection between the ureter and vas deferens. This is usually not done in the newborn period as the main criteria to decide at that time is whether or not a colostomy will be required.

In cases that have undergone colostomy in the newborn period, a distal cologram is performed to delineate the fistulous communication.

The newer imaging modalities, namely CT scan and MRI scan are not really essential for managing a neonate, though their information is valuable in delineating the anatomy in complicated cases or those requiring a redo surgery.

## Management

### Low ARM

Perineal procedures can be carried out safely on all neonates with a very low lesion.

- Anal stenosis
  - Dilatations—minimal stenosis can be cured by repeated dilatations
  - Y-V plasty—a posterior V flap of sensitive perianal skin is sutured into the posterior wall of the anal canal after this is opened up
  - Limited posterior sagittal anoplasty can achieve the same objective
- Imperforate anal membrane can be perforated easily.
- A low anocutaneous fistula can be opened up by a cutback to the normal anal site and the operation completed as a Y-V plasty or a limited sagittal anoplasty.
- Anterior ectopic anus—anal transposition
  - Limited posterior sagittal anorectoplasty (PSARP)
- Vestibular anus—PSARP/anal transposition.

*Anal transposition:* A circumferential incision is made around the opening; the bowel is separated posteriorly and laterally from the surrounding levator sling, and anteriorly from the posterior surface of the vagina until bowel of normal calibre is reached. Separation is easily achieved in the relatively low lesions but is difficult if there is a long tract adherent to the whole length of the vagina and dissection has to be continued up to the level of the peritoneal reflection.

*Anterior sagittal anorectoplasty (ASARP):* The ASARP dividing all the muscles between the posterior wall of the vestibule and the normal anal site strictly in the midline, and repairing the muscles after placing the bowel in the normal position have claimed equally good results.

Perineal fistula in both boys and girls is also similarly treated, namely by anal transposition or by sagittal anorectoplasty; the latter is more commonly performed. The procedure is generally easier but is difficult in boys who have a long perineal tract densely adherent to the posterior wall of the urethra; in these patients the dissection has to be continued up to the bladder base and the peritoneal reflection.

### High and Intermediate Level ARM

#### Colostomy

It is usually performed as a first stage in a newborn with high anomaly. Transverse loop colostomy is simple to perform and close loop stoma is suitable in neonates when early reconstruction and closure is contemplated. Authors prefer a high sigmoid loop colostomy in newborns with ARM, but a right transverse colostomy for cases with common cloaca, so that the adequate distal colon is available for future pull-through.

Colostomy should be urgently performed on the neonate who presents without a visible opening of the bowel, with low

birth weight, with bilious vomiting and abdominal distension and with a life-threatening associated anomaly. The colostomy should generally be done at the most proximal part of the sigmoid colon by a left lower quadrant incision. This loop of bowel is exteriorised and the site for colostomy is carefully selected. Both the limbs of the loop are approximated for about 2 cm, so as to form a dividing spur between the two loops. The cut margins of the peritoneum and the abdominal wall muscles are sutured to the seromuscular coat of the exteriorised colon; this is then opened and both loops are emptied of meconium. The mucosa of the bowel is sutured to the skin margins. The site of the colostomy has to be modified when there is associated pouch colon.

## Anorectal Reconstruction

### Posterior Sagittal Anorectoplasty

The description of the PSARP by deVries and Pena (1982) is a landmark achievement in the recent times to develop a new approach in surgery of this region. It is the operation of choice for almost all types of ARM cases. However, in cases of difficulty to achieve mobilisation, an additional abdominal approach can be added.

The operation is performed with the baby in the knee-elbow position. The parasagittal and vertical fibres of the striated muscle complex are identified and stay sutures are placed to mark the anterior and posterior limits of the vertical fibres. The parasagittal and the posterior half of the vertical fibres are incised in the midline and the coccyx is split also in the midline. A right angle clamp is introduced into the presacral space. The levator ani is then exposed and incised in the midline. The rectal pouch is identified and opened. The urethral fistula if present is identified; a circumferential incision is made on the bowel mucosa around it and the fistula closed. The anterior wall of the bowel is then dissected until the peritoneal reflection is reached; the posterior wall is mobilised by opening up the retrorectal space. The fibrovascular bands are divided and the bowel can then be pulled to reach the normal anal site. It is sutured in place and the divided muscles repaired. Bowel tapering is optional. A urethral catheter is left in the bladder for a few days.

In girls without a fistula or with a rectovaginal or low rectocloacal fistula, a similar operation is performed.

An end-to-end anastomosis can be carried out through a similar approach for rectal atresia if the gap between the two parts of bowel is small (up to 1 cm).

### Abdomino PSARP

It is done either:

- In doubtful cases where one is not sure of finding the rectal pouch by PSARP route

- In cases with higher level of fistula
- In cases where there is suspicion of pouch colon preoperatively
- As a planned procedure by some as they feel the anatomic postoperative location of the rectal pouch is better by this procedure.

In Abdomino PSARP, the first stage of the operation is done as for PSARP in prone position and then a red rubber catheter of adequate size as that of the expected rectal pouch is placed as a tunnel and the muscles are approximated around it.

The patient is then turned in the lithotomy position, redraped and a curved left lower abdominal incision is given. The bowel is identified; the fistula is divided and closed if not done earlier by the PSARP route. The bowel is prepared for pull-through by dividing blood vessels in the mesocolon as necessary.

### *Abdominoperineal Pull-Through*

This is required for the high anorectal malformations as an alternate to PSARP. In lithotomy position, the abdomen is opened with a curved lower abdominal or suprapubic incision. The bowel is mobilised, the fistula is identified, divided and repaired. The bowel is prepared for pull-through by dividing blood vessels in the mesocolon preserving an arcade of vessels to maintain the blood supply of the mobilised loop.

The operation then shifts to the perineal route and an incision is given over the proposed anal site. Dissection is done strictly in the midline up to the peritoneal dissection.

A tunnel is made between the urogenital organs and the levator sling and the bowel is pulled through to reach the normal anal site. The bowel is fixed in place by seromuscular stitches followed by mucocutaneous anastomosis taking care to avoid mucosal prolapse or retraction. It is also taken care that the anastomotic line is inverted inside the new anal opening so as to look like the normal lower end of the anal canal which is skin lined.

In girls with cloacal malformations, the urethral passage may be narrow and urine may accumulate both in the bladder and in the vagina; this urocolpos aggravates obstructive uropathy by external pressure on the ureters.

### **Continence**

Good bowel control is usually achieved after correction of low anomalies in about 90% of patients. In case of high anomalies, it depends on the sacral, muscular and sphincteric development. After Pena's PSARP, the reported results of continence have markedly improved worldwide.

### **Summary**

Anorectal agenesis has a varied spectrum of anomalies and each case should be examined carefully with a wide knowledge of the anatomical variations and identification of rare anomalies when encountered so that the best possible treatment option can be adopted to have the best continence results. In the authors' experience, colostomy is performed in most neonates with ARM presenting after 48 hours or so with distension of abdomen. However, if the baby is presented early and the distal bowel is not much dilated, we prefer a single-stage PSARP in the newborn period without a covering colostomy.

### **NEURAL TUBE DEFECTS**

The incidence of apparent neural tube defects (NTDs) also known as spina bifida aperta is approximately 0.8–1 per 1,000 live births, but there is a wide geographical variation. A decrease in incidence has been noted as a result of improved maternal nutrition and antenatal diagnosis with elective termination.

### **Definition**

There are three main types of spina bifida aperta.

1. *Meningocele*: A meningocele is a skin-covered lesion, which consists of cerebrospinal fluid (CSF), meninges and skin. There is usually no associated neurological deficits or hydrocephalus.
2. *Myelomeningocele*: A myelomeningocele is a parchment membrane covered lesion that in addition to CSF and meninges also contains the neural plaque, which is usually an abnormal conus medullaris. Associated hydrocephalus is noted in 75–90% patients and neurological deficits are common (Figs 10.7 to 10.9).



**Fig. 10.7:** Lumbosacral meningocele





Fig. 10.8: Cervical meningocele

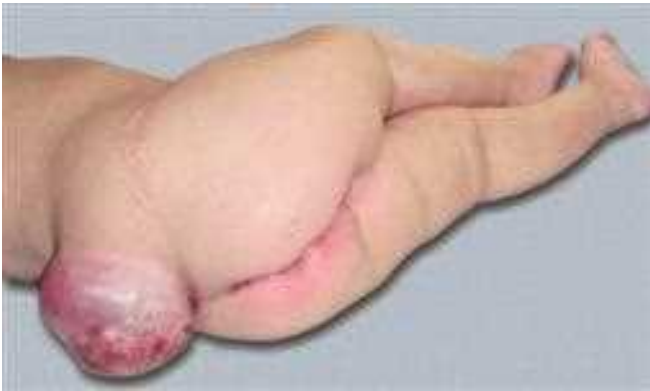


Fig. 10.9: Sacral meningocele with gross deficits; paresis, neurogenic bladder and bowel

- Rachischisis refers to a large neural placode with open central canal without any encasing meninges. It is usually associated with severe hydrocephalus and neurological deficits.

### Embryology

The primitive streak appears at the caudal end of the embryo in stage 6 (Day 13–15) and elongates cranially. The Hensen's node is at the cranial end of the primitive streak. The epiblast cells migrate through the primitive groove and form the endoderm and mesoderm (gastrulation) during stage 6. As the primitive streak regresses the notocord is formed which has a central canal. The notocord induces the overlying ectoderm to form the neural plate, the lateral ends of which form neural folds that fuse in the midline to form the neural tube (neurulation-stage 8–12, 18–27 days). The formation of the neural tube starts from the cervical region and proceeds cranially and caudally. The anterior and posterior neuropores close at about 23–25 days of gestation respectively. The superficial ectoderm fuses in the midline and mesenchymal cells migrate between the neural tube and skin to form the meninges, neural arches and muscles.

By day 25, the caudal end of the neural tube blends into the caudal cell mass. Small vacuoles form in the caudal cell mass, which coalesce and eventually connect with the central canal of the cord by a process called canalisation. The distal spinal cord then involutes (retrogressive differentiation) to form the filum terminale and the differential growth causes the conus medullaris to ascend. The conus lies at the L2–3 interspace at birth and reaches the adult position (L1–2) by 3 months of age.

### Theories on Embryogenesis of Neural Tube Defects

- Simple non-closure*: This theory postulates that the normal process of neural fold formation and closure is interrupted in a localised area leading to a NTD.
- Overgrowth and non-closure*: The overgrowth of the neural epithelial cells interferes with the normal folding and neural tube formation.
- Reopening*: This theory states that the neural tube reopens after closure as a result of degenerative changes at the junction of the ectoderm and neural tissue.
- Overgrowth and reopening*: The overgrown dorsal caudal neural plate is exposed after normal closure has taken place.
- Primary mesodermal insufficiency*: The mesodermal defect is the primary event that leads to the NTD.

### Aetiology

Aetiological factors implicated in NTDs include alcohol, drugs like carbamazepine and valproate, malnutrition and folate deficiency.

### Epidemiology

Myelomeningocele is the single most common congenital defect of the central nervous system. Relation with maternal age and nutrition, parity, seasonal variation and a host of other environmental factors have all been implicated as aetiological factors. The risk of recurrence is believed to be around 3–5%.

### Prenatal Diagnosis and Prevention

- Screening*: Maternal serum alpha-fetoprotein (AFP) levels at 16th to 18th week of gestation, if raised, suggests a NTD but this test has a sensitivity of around 75% only and is not expected in skin covered lesions. Elevated amniotic fluid AFP and acetylcholinesterase measurement also suggests NTD but false-positive results can be expected.
- Foetal ultrasonography may visualise the spinal placode or splaying of the posterior elements or vertebral anomalies. Indirect signs of myelomeningocele are more easily detected and include the banana sign (elongated

appearance of the cerebellum secondary to the Chiari malformation) and the lemon sign (inward appearance of the frontal bones). The lemon signs detect 80% of NTD as compared to 93% with the banana sign. Ventriculomegaly (> 10 mm lateral ventricular atrium diameter) is usually more common after 24 weeks of gestation.

- Up to 14% of foetuses with NTD detected in the 2nd trimester have associated trisomy 13 or 18 and therefore, it is mandatory to do a chromosomal analysis prior to taking a decision regarding further management.

The risk of recurrence is around 1–3% and it is mandatory that mothers with one affected child be started on 5 mg/d of folic acid 3 months prior to a planned pregnancy. Prenatal repair of myelomeningocele *in utero* has been attempted to decrease the risk of neurological deficits as a result of trauma or amniotic fluid exposure.

Caesarean section or continuation of pregnancy is contraindicated in presence of chromosomal abnormality, associated anomaly, advanced hydrocephalus, flat lesion at or below plane of the back and absent knee and ankle movements.

### Associated Anomalies in Myelomeningocele

- Hydrocephalus 80–90%
- Chiari malformation
  - Nearly 100%
  - Clinically significant: 10–20%
- Brain
  - Micropolygyria
  - Cerebellar dysgenesis
  - Corpus callosum agenesis
  - Cysts
- Vertebral anomalies
  - Fusion defect
  - Hemivertebrae
  - Butterfly vertebrae
- Scoliosis/Kyphosis (30%)
- Genitourinary
  - Undescended testes
  - Vesicoureteric reflux
  - Hydronephrosis
- Club feet
- Others—cardiovascular anomalies, cleft palate, congenital dislocation of hip and hernias.

### Clinical Assessment

#### Evaluation of the Lesion

- Size, shape of lesion; presence of scoliosis/kyphosis; laxity of surrounding skin to plan surgery
- Evidence of CSF leak or infection
- Transillumination to assess the amount of neural tissue in sac.

#### Evaluation of Lower Limb Power, Tone and Reflexes

- There is usually flaccid paralysis with lumbosacral meningomyeloceles. In cervical/and some of the thoracic lesions there may be features of spasticity
- Deformities of the foot and evidence of flexion contractures
- Note grade of muscle power in limbs by stimulating upper abdomen or chest.

#### Evaluation of Hydrocephalus

- Note the initial head circumference, fullness of anterior fontanelle, squamo-parietal sutural diastasis and 'setting-sun sign'.

#### Evaluation of Lower Cranial Nerves and Brainstem Function

- Look for regurgitation, difficulty in feeding, stridor, apnoea, hypotonia, which suggests a significant Chiari malformation (poor prognostic factor).

#### General Paediatric Assessment

- To rule out associated anomalies or chromosomal anomalies (club feet, congenital heart disease, cleft palate, hernias, congenital dislocation of the hips, genitourinary abnormalities).

#### Evaluation of the Bladder/Bowel

- Elicit the anocutaneous reflex and bulbocavernosus reflex
- Palpate for bladder/kidneys and check if bladder is expressible; note urinary stream. It is important to note that if one leg is normal, bladder function can be expected to be normal.

### Clinical Examination and Investigations

#### Motor examination

- Hip flexion
- Hip adduction
  - Knee extension
- Hip abduction
  - Hip extension
  - Knee flexion
- Plantar flexion

#### Nerve roots

- L1–3
- L2–4
- L5–S2
- S1

### Investigations

- Ultrasound
  - Sac
  - Head
  - Kidney
  - Post-void residue
- CT/MRI
  - CNS abnormalities
  - Hydrocephalus
  - Other vertebral anomalies
- Routine preop workup

### Counselling and Selection Criteria

The following factors help the surgeon in arriving at a decision and counselling the parents:

- Age and general condition at presentation
- Size, shape and level of defect
- Presence of infection or CSF leak
- Status of lower limbs and sphincters
- Presence of hydrocephalus
- Socioeconomic status of parents and family history.

### Parents are Explained Regarding

- Prognosis in terms of ambulation, mental development and continence of urine and faeces
- Need for shunt surgery in up to 75–80% cases with its associated complications and revisions
- Need for urological and bowel treatment with repeated follow-up and surgical intervention as needed
- Risk of surgery and chances of secondary tethered cord later
- It is important to understand that the parents should ultimately decide regarding the management, but it is the duty of the surgeon to give the correct picture in detail. Also, it must be remembered that not all untreated children die and may present later with a far worse neurological status. A few of them may require surgery of the large sac for better nursing care.

### Preoperative Care

Besides maintaining normothermia and the standard neonatal care, these children have to be nursed prone. The lesion is covered with sterile and saline soaked dressings. A deep head ring may be helpful for nursing. Preoperative antibiotics are used routinely in antimeningitic doses.

### Principles of Operation

- Proper positioning, adequate intravenous lines, temperature control are vital
- Use of bipolar coagulation and optical loupes are advisable
- Sac mobilised from the skin and subcutaneous tissues and neck delineated
- Central membrane and placode separated by sharp dissection from the sac. Cord detethered by dividing arachnoid adhesions and epithelial elements trimmed from the placode
- Neural placode retubularised by 7–0 interrupted sutures on the pia-arachnoid tissues
- Dura dissected from the sac and areolar tissue, closed with continuous 5–0 prolene or Vicryl
- Third level closure using fascial flaps or preferably using the left over viable sac elements

- Wide mobilisation of the skin and subcutaneous tissues till the lateral abdominal wall (if necessary) and also superiorly/caudally
- Closure of subcutaneous tissue (4th layer) and skin (5th layer)
- Tight barrier dressing.

### Postoperative Care

- Routine antibiotics, nurse prone
- Mannitol for 3 doses followed by oral diamox (50–100 mg/kg per day) the next day
- Monitoring of head circumference and serial ultrasound for hydrocephalus
- Watch for Chiari malformation complications
- Monitor postoperative neurological status
- CSF leak is managed by increasing diamox dose and CSF shunting
- Barrier dressing at all times to prevent infection
- Monitor post-void residue; institute clean intermittent catheterisation or anticholinergics early
- Explain postoperative care; follow-up protocols, physiotherapy, expected complications and long-term problems in detail.

## HYDROCEPHALUS

Hydrocephalus is defined as a dilatation of the cerebral ventricles caused by a discrepancy between CSF production and absorption.

The incidence of infantile hydrocephalus is around 3–4:1,000 live births. Congenital hydrocephalus comprises about one-third of all congenital malformations of the nervous system.

### Cerebrospinal Fluid Production

- *Choroid plexus*: Eighty percent of the CSF is formed by the choroid plexus of the lateral, 3rd and 4th ventricles by an active transport process across the endothelium of capillaries in the villus processes of the choroid plexus. Each villus is lined with a single layer of cuboidal epithelium and has a central stromal core. The apical tight junctions represent the blood-CSF barrier. Na-K ATP are located in the microvilli extrudes sodium ion into the ventricle which osmotically draws water along with itself. Na<sup>+</sup> transport is balanced by counter transport of K<sup>+</sup> and/or H<sup>+</sup> ion. Carbonic anhydrase catalyses formation of bicarbonate inside the cell, with the H<sup>+</sup> ion being fed back to the Na<sup>+</sup> transporter as a counter ion in exchange of K<sup>+</sup>.

- *Ependymal surface*: The ependymal surface is also believed to be a site of CSF production and may contribute up to 15–30% of the total CSF production.
- *Brain parenchyma*: Intracerebral injection studies suggest bulk flow of brain interstitial fluid in white matter which is an important source of nonchoroidal CSF production.

Clinical studies have shown that the CSF formation rate is around 20 ml/hr in adults and the total CSF volume in the ventricles and subarachnoid space is approximately 150 ml.

### Cerebrospinal Fluid Absorption

The rate of CSF absorption is pressure dependent and relatively linear over a wide physiologic range. CSF formation is independent of pressure whereas CSF absorption increases linearly after 68 mm H<sub>2</sub>O pressure. Below 68 mm H<sub>2</sub>O pressure there is no CSF absorption. The formation and absorption rates become equal beyond 112 mm H<sub>2</sub>O pressure.

### Site of Cerebrospinal Fluid Absorption

- Arachnoid villus
- Brain capillaries
- Choroid plexus
- Lymphatic system
- Nerve root sleeves

With the single exception of choroid plexus papilloma that results in CSF overproduction, hydrocephalus results basically secondary to impaired absorption.

### Classification and Aetiology

In the past, depending on the site of obstruction hydrocephalus was classified as:

- *Noncommunicating*: Blockage of CSF pathway at or proximal to the outlet foramina of the 4th ventricle.
- *Communicating*: Obstruction located in the basal subarachnoid cisterns, subarachnoid sulci or the arachnoid villi.

### Anatomic Aetiologic Classification of Hydrocephalus

#### *Non-communicating*

#### A. Obstruction of CSF pathways

##### 1. Congenital

- Aqueductal obstruction
- Atresia of foramen of Monro
- Dandy Walker malformation
- Benign intracranial cysts
- Arnold-Chiari malformation

#### *Communicating*

##### 1. Congenital

- Arnold-Chiari malformation
- Dandy Walker malformation
- Encephalocele
- Incompetent arachnoid villi
- Benign cysts

- Skull base anomalies
- X-linked aqueductal stenosis in males

#### 2. Neoplastic

- Choroid plexus papilloma
- Medulloblastomas, ependymomas, craniopharyngiomas, astrocytomas

#### 3. Inflammatory

- Infectious ventriculitis
- Chemical ventriculitis
- Intraventricular haemorrhage

#### B. Overproduction of CSF Choroid plexus papilloma

#### 2. Neoplastic

- Infectious meningitis
- Sub-arachnoid haemorrhage
- Chemical arachnoiditis

#### 3. Inflammatory

### Pathophysiology

The subarachnoid channels adjacent to the arachnoid villi represent the first CSF compartment to dilate and reduce CSF pressure. Subsequently with progressive dilatation of the subarachnoid channels, the increase in CSF pressure is transmitted to the ventricular system resulting in ventriculomegaly. Ventricular enlargement causes displacement of primary cerebral arteries and a reduction in the calibre and number of the secondary and tertiary vessels causing diminished blood flow and ischaemia.

The effects of raised intracranial pressure (ICP) on the developing brain include:

- White matter atrophy
- Stretching and damage of ependymal epithelium with formation of ventricular diverticulae
- Spongy oedema of the brain parenchyma
- Fenestration of the septum pellucidum and thinning of the interhemispheric commissure.

The atrophy involves primarily the axons and neurons of the grey matter are selectively spared due to better blood supply. The previous view of using cerebral mantle thickness as a prognostic criterion in hydrocephalus is, therefore, losing favour.

### Clinical Presentation

The signs and symptoms related to hydrocephalus depend on the age of the patient, causative factor, associated malformations or cerebral insult and the severity and progression of the disease.

## Newborn and Infant

The infant with hydrocephalus presents with macrocrania, a bulging anterior fontanelle, poor feeding and lethargy. The infant may have sutural diastasis particularly the squamosoparietal suture. The other signs of hydrocephalus include dilated scalp vein, Parinauds phenomenon (sunset sign caused by pressure on the tectal plate) and Macewen's sign (cracked pot resonance). The infant will have delayed milestones and difficulty in head control. Apneic bouts and bradycardia are usually associated with posterior fossa anomalies and are rarely seen in other causes of progressive hydrocephalus. During the first 3 months of life, normal head growth velocity is 2 cm/month. Head circumference more than 97th percentile for gestation age is suggestive of hydrocephalus. Transillumination can be appreciated in cases of hydranencephaly and in infants less than 9 months of age with cerebral mantle less than 1 cm. Cranial nerve palsies and stridor may also be seen in infants. The discrepancy between head and chest circumference may suggest hydrocephalus. Normally the head measures about 1 cm more than the chest circumference until late in the first year when it reverses.

## Older Child

The inability of the fused cranium to expand means that older children usually have a more acute presentation and the triad of severe headache, vomiting and lethargy is commonly seen. Papilloedema is commonly seen in children unlike infants. Delayed motor and cognitive development and subtle behavioural changes are noted. A mild spastic diplegia with positive Babinski sign can also be elicited. The other indicators of hydrocephalus include decreased active leg motion, poor placing and positive support reflexes.

## Differential Diagnosis of Macrocrania

- Hydrocephalus
  - Hygroma
- Subdural fluid
  - Haematoma
  - Effusion
- Brain oedema
  - Toxic — lead encephalopathy
  - Endocrine — galactosaemia
- Familial or constitutional macrocrania
- Gigantism
- Achondroplastic dwarfism
- Leukodystrophy, e.g. Alexander's disease
- Lysozymal disorders
- Aminoaciduria
- Thickened skull, e.g. thalassaemia, cranioskeletal dysplasias
- Hydranencephaly.

## Imaging

The goals of imaging in hydrocephalus are:

- Confirm the presence of hydrocephalus
- Evaluate aetiology of hydrocephalus
- Assess result of treatment and prognosticate in terms of long-term intellectual development.

## Ultrasonography

Ultrasound is used in the presence of an open anterior fontanelle the relative ease and noninvasive nature makes ultrasonography particularly useful in evaluating the premature infant. It is also useful for follow-up screening.

## Computed Tomography

Computed tomography (CT) scanning is the most commonly used imaging modality to evaluate macrocrania or signs of raised ICP. The cause and site of obstruction can usually be defined and with contrast enhancement tumours as well as vascular lesions can be visualised. Dilatation of the temporal horns is a sensitive indicator of raised ICP. The presence of periventricular oedema or ooze suggests high ICP.

## Magnetic Resonance Imaging

The axial, coronal and sagittal images available with magnetic resonance imaging (MRI) provide a more exact position and extent of the lesion. MRI can also locate small tumours in the upper cord and brainstem, which may be missed on a CT scan.

## Other Diagnostic Studies

- *CSF evaluation*: CSF examination for protein and cell content is important prior to shunt placement in post-meningitic hydrocephalus. Fat laden cells are indicative of brain damage in post-infection states and can also be evaluated by CSF examination.
- *Neuropsychologic evaluation*: The child with hydrocephalus can exhibit problems with learning and development. Subtle changes in school performance or MPQ assessment may indicate progression of hydrocephalus or shunt dysfunction.
- *Cerebral blood flow and Doppler studies*: Transcranial Doppler flow studies and PET scanning have also been used for diagnosing and follow-up of hydrocephalus. Trans-systolic time (TST) is a new Doppler index used to evaluate ICP. Fundus evaluation to assess severity of raised ICP.

## Post-meningitic Hydrocephalus

Meningitis of bacterial (including tubercular) and non-bacterial origin is the most common cause of acquired hydrocephalus,

which produces obstruction to CSF flow usually at the subarachnoid level. The incidence of hydrocephalus following meningitis ranges between 1% and 5%. Intrauterine viral infection with cytomegalovirus, rubella, mumps, varicella and parainfluenza is also responsible for congenital obstructive hydrocephalus of the noncommunicating variety.

### Post-tuberculous Meningitis Hydrocephalus

Neurotuberculosis constitutes almost half of the cases of childhood tuberculosis and tuberculous meningitis (TBM) is the most common manifestation of CNS tuberculosis. The causes of hydrocephalus following TBM include:

- Communicating hydrocephalus due to blockage of basal cisterns by the tuberculous exudate in the acute stage and adhesive leptomeningitis in the chronic stage
- Noncommunicating hydrocephalus caused by blockage of the aqueduct or outlet foramina of the 4th ventricle.

### Post-haemorrhagic Hydrocephalus in the Premature Infant

Haemorrhage into the germinal matrix of the immature brain and extension into the ventricular system remains a major problem in premature neonates. Post-haemorrhagic hydrocephalus is secondary to a fibrous thickening of the meninges with an obliterative arachnoiditis and obstruction of CSF flow through the normal subarachnoid pathways.

### Diagnosis

Diagnosis is confirmed on ultrasonography or documentation of raised ICP. Post-haemorrhagic hydrocephalus presents with—increasing occipitofrontal head circumference, tense anterior fontanelle, lethargy, feeding difficulty, bradycardia and ventilator dependency. The other manifestations include SIADH, persistent metabolic acidosis, abnormal eye movements and hypertonia.

### Treatment

The communicating hydrocephalus resulting secondary to intraventricular haemorrhage can be managed by:

- Serial lumbar punctures—repeated lumbar punctures are done to relieve ICP as necessitated by clinical or ultrasonological examination. Serial lumbar punctures have been reported to resolve post-haemorrhagic hydrocephalus in selected cases in 1–6 weeks
- Acetazolamide (50–100 mg/kg per day) and furosemide (2 mg/kg per day) with careful electrolyte and acid-base status monitoring
- Ventriculostomy/Valveless shunts
- The recent use of flexible ventriculoscopes for irrigation, evacuation of blood or to lyse intraventricular septations may decrease the need for shunting.

### Management of Antenatally Detected Hydrocephalus

Recent studies have dampened the enthusiasm of treating antenatally detected hydrocephalus in view of the poor prognosis and ill-defined natural history of the disorder. It is now accepted that the overall mortality in foetuses with antenatally detected ventriculomegaly is around 70% while only 50% of the survivors show normal intellectual development. The incidence of associated anomalies with antenatally detected hydrocephalus is reported to be as high as 81%. Moreover 20–40% of these anomalies can be missed on antenatal sonography. The high rate of complications associated with the ventriculo-amniotic shunt and need for multiple revisions secondary to dislodgement and blockage.

### Congenital CSF Anomalies of the Posterior Fossa

The restricted area of the posterior fossa with its vital contents and frequent aberrant anatomy poses a diagnostic and therapeutic challenge. The various anomalies seen are:

- Arachnoid and neuroepithelial cysts
- Dandy-Walker malformation
- Isolated 4th ventricle
- Pulsion diverticulum
- Mega cisterna magna and ex-vacuo states.

### Treatment

The goals in the treatment of hydrocephalus include:

- Decrease the intracerebral pressure to safe levels
- Increase the volume of brain parenchyma to maximise the child's neurological development
- Minimise the likelihood of complications, detect and aggressively treat any complications
- Maintain the integrity of CSF pathways to prevent ventricular coaptation and preserve the potential for life without shunt dependency.

### Medical Treatment

The medical treatment of hydrocephalus is not an alternative for shunt surgery but has a definite role in some clinical situations. The potential for spontaneous arrest of hydrocephalus exists in infants due to the linear increase in CSF absorption seen with increase in ICP. The four modalities of medical treatment of hydrocephalus are given as follows.

#### *Removal of Cerebrospinal Fluid*

The rate of CSF production is around 0.02 ml/min in neonates and the total ventricular CSF volume varies between 5 ml and 15 ml. Serial lumbar puncture for CSF removal is indicated

in hydrocephalus secondary to intraventricular haemorrhage in infants and treatment of normal pressure hydrocephalus in adults. Meningitis, vertebral osteomyelitis and hypernatraemia are the potential complications of the procedure.

### *Decrease Cerebrospinal Fluid Production*

*Carbonic anhydrase inhibitors:* Acetazolamide is a potent inhibitor of carbonic anhydrase. Furosemide is another agent used in inhibiting choroidal CSF production. Both the drugs can reduce CSF flow by 50–60% at sufficient doses. Acetazolamide is given in the dose of 50–100 mg/kg and furosemide at 1 mg/kg. Nearly all infants receiving acetazolamide at these doses will develop metabolic acidosis. Furosemide on the other hand causes metabolic alkalosis and nephrocalcinosis.

### *Decrease Brain Water Content*

Osmotic diuretics increase the outflow of water from the interstitial space into the capillaries. Osmotic diuretics are effective temporarily in reducing ICP but prolonged use can lead to a rebound effect with an increase in interstitial water. Isosorbide, mannitol, urea and glycerol are the common agents, which have been used.

### *Increase Cerebrospinal Fluid Absorption*

Hyaluronidase, urokinase, streptokinase and tissue plasminogen activator have been used experimentally to lyse fibrin blocking the subarachnoid villi following haemorrhage.

## **Surgical Treatment**

The decision to perform a CSF shunting procedure has to be taken with care. The risks involved in performing the procedure are low but the nature of complications associated with shunting are serious. There is a very variable course and progression of hydrocephalus and its effect on intellectual development. Studies have demonstrated that a cerebral mantle of 2.8 cm is adequate to achieve normal MPQ status in follow-up. It is believed that the goal for treating a child with hydrocephalus is to achieve a cerebral mantle of 3.5 cm by the age of 5 months.

Ventricular catheters are usually made of Silastic (silicone polymer) and have radio-opaque markings or barium impregnation for visualisation.

The proximal catheter is placed in the lateral ventricle ideally anterior to the foramen of Monro. Presently the peritoneum is the preferred receptacle for the distal catheter.

Four types of valves are currently available: (1) slit valve, (2) ball in cone valve, (3) diaphragm valve and (4) miter valve. The most common shunt performed is the ventriculoperitoneal shunt. Recently 3rd ventriculostomy is gaining popularity.

Ventricular shunt complications include:

*Common to all types of shunt:*

- Malfunction
  - Obstruction
  - Disconnection or fracture
  - Shunt migration
- Shunt infection
- Overdrainage
  - Slit ventricle syndrome
  - Subdural/Extracerebral CSF collections
  - Craniosynostosis
- Seizures
- Pneumocephalus
- Isolated ventricle syndromes.

*Complications unique to peritoneal shunts:*

- Inguinal hernia and hydrocele
- Ascites
- Cyst formation
- Intestinal volvulus and obstruction
- Bowel perforation, bladder perforation
- Intraperitoneal spread of infection and malignancy.

## **Long-Term Follow-Up Results**

Mortality in hydrocephalus patients is usually related to the aetiology and associated conditions. Most published series report long-term survival rates of 50–90% in surgically treated patients. The natural history of untreated hydrocephalus is dismal and only 20% of patients survive till adulthood.

The best functional results after shunt surgery are obtained in infants below 5 months of age. The care of children with hydrocephalus requires a multimodality approach. Early treatment and regular follow-up can insure a favourable outcome in these children.

## **ACKNOWLEDGEMENTS**

Some photographs in this chapter have been taken from “Textbook of Neonatal Surgery” Edited by DK Gupta, MBD Publishers, New Delhi in 2000, with prior permission from the publishers.

# General Paediatric Surgery

## CLEFT LIP AND PALATE

### Introduction

Cleft lip and palate is a congenital anomaly, presenting in a wide variety of forms and combinations. Cleft lip and palate are among the most common of congenital deformities. Cleft lip ranges from notching of the lip to a complete cleft, involving the floor of the nose, and may be associated with a cleft of the primary palate (alveolus or premaxilla) and with clefts of the secondary palate (hard and soft palate). Chinese physicians were the first to describe the technique of repairing cleft lip. Currently Millard technique of rotating the medial segment and advancing the lateral flap; thus, preserving the Cupid's bow with the philtrum is widely done.

### Embryology

During the early stages of pregnancy, the upper lip and palate develop due to insufficient mesenchymal migration during primary palate formation in the 4th through 7th week of intrauterine life normally, as the face and skull are formed; these tissues grow towards each other and join up in the middle. When the tissues that form the upper lip fail to join up in the middle of the face, a gap occurs in the lip. Usually a single gap occurs below one or other nostril (unilateral cleft lip). Sometimes there are two gaps in the upper lip, each below a nostril (bilateral cleft lip).

### Aetiology

What causes clefts are not known exactly, but most believe they are caused by one or more of three main factors: (1) an inherited gene defect from one or both parents, (2) environment exposure to any teratogenic agent like anticonvulsant drugs, e.g. phenytoin and sodium valproate, during pregnancy is associated with a tenfold increase and is twice more in infants whose mothers smoke or consume

alcohol during pregnancy (poor early pregnancy health or exposure to toxins such as alcohol or cocaine) and (3) genetic syndromes like Van der Woude syndrome, Pierre Robin syndrome and Down syndrome are associated with clefts of the lip and palate.

### Classification

Veau-Wardill categorised clefts into the following four major types (Fig. 11.1):

1. Clefts of the soft palate alone
2. Clefts of the soft and hard palate
3. Complete unilateral clefts of the lip and palate
4. Complete bilateral clefts of the lip and palate.

This classification does not provide a means of classifying clefts of the lip alone and ignores incomplete clefts. Kernohan stripped-Y classification describes the cleft of the lip, the alveolus and the palate. In this classification, the incisive foramen defines the boundary between clefts of the primary palate (lip and premaxilla) and those of the secondary palate.

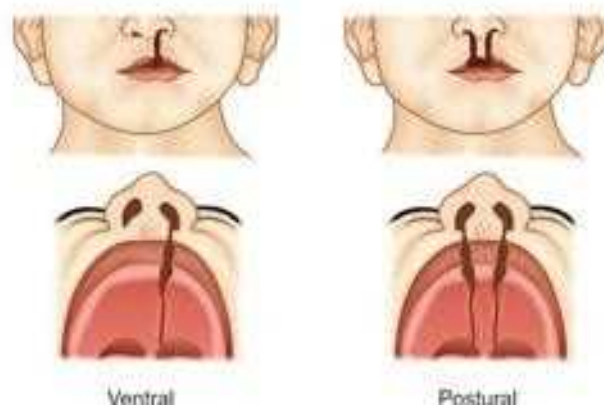


Fig. 11.1: Cleft lip and cleft palate, facial clefts drawing indicating the possibilities of oral and facial clefts



## Incidence

The incidence of cleft lip is approximately 1 in 1,000 live births. The incidence in the Asian population is twice as great but in the black population it is less than half. Male children are affected more than female children. Isolated unilateral clefts occur twice as frequently on the left side as on the right and are 10 times more common than bilateral clefts. Combined cleft lip and palate is the most common presentation (50%), followed by isolated cleft palate (30%), and isolated cleft lip or cleft lip and alveolus (20%). In 10% of cases clefts are bilateral.

## Complications of Clefts

The complications of cleft lip and cleft palate can vary greatly depending on the degree and location of the cleft. They can include all or some or all of the following:

- **Feeding:** Problems with feeding are more common in cleft children; there can be nasal regurgitation or aspiration into airway. Special feeding devices or feeding with ink filler is advised. Children with a cleft palate may need to wear palate prosthesis.
- **Ear infections and hearing loss:** Cleft palate can affect the function of the eustachian tube and increase ascending infection of middle ear which is a primary cause of repeated ear infections. Hearing loss can be a consequence of repeated otitis media.
- **Breathing:** When the palate and jaw are malformed, breathing becomes difficult especially when associated with Pierre Robin syndrome.
- **Speech problem:** Normal development of the lips and palate are essential to speak clearly. The causes of speech problem are incorrect lip pressures, tongue malposition, velopharyngeal incompetence, abnormal neuromuscular function, abnormal jaw relationships, abnormal dentition and secondary hearing loss due to otitis media. Speech therapy helps with language development after surgical repair.
- **Dental problems:** Cleft involving the gums and jaw can affect the growth of teeth and alignment of the jaw. Orthodontic appliance or bone graft surgery helps this problem. A defect in the alveolus can: (1) displace, tip or rotate permanent teeth, (2) prevent permanent teeth from appearing and (3) prevent the alveolar ridge from forming.

## Investigation

No investigation is needed for confirmation of diagnosis, as it is a clinical diagnosis. Haemogram for anaesthesia purpose and throat swab is done for excluding beta haemolytic streptococci carrier state, which can cause disruption of

postoperative palate wound by producing fibrinolysin. Cardiac evaluation, including echocardiography, if cleft is associated with cardiac anomalies.

## Treatment

### *Aims of Treatment*

Therapeutic goals to be achieved by primary surgery are restoration of normal anatomy, restoration of normal/near normal function, promotion of normal development resulting in satisfactory facial appearance, speech, hearing and skeletal jaw relationships.

### *Timing of Surgery*

- Cleft lip repair—between birth and 3 months
- Cleft palate repair—by one year of age
- Follow-up surgeries—between age 2 and late teen years.

### *Operative Procedures*

For lip: Unilateral or bilateral (complete/incomplete) procedures including Millard, Delaire, Le Mesurier, Pfeiffer and others are available. Millard introduced the rotation-advancement technique, which is the most commonly used method today for the repair of unilateral clefts. The technique preserves the Cupid's bow and the philtral dimple and improves nasal tip symmetry. The rotation-advancement lengthens the lip by means of a rotation incision that releases the medial lip element, allowing the Cupid's bow to rotate downwards into normal position. The lateral lip element is advanced into the gap created by rotation of the medial element, thus completing reconstruction of the upper lip.

For cleft palate: One-stage or two-stage, methods of closure include Von Langenbeck, Veau, Kilner- Wardill, Delaire, Malek, Furlow and others. Cleft palate repair requires more extensive surgery and is usually done when the child is 10–15 months old. The principle of cleft palate surgery is an incision made on both sides of the separation, moving tissue from each side of the cleft to the centre or midline of the roof of the mouth. This rebuilds the palate, joining muscle together and providing additional length in the palate so the child can eat and learn to speak properly.

Secondary surgery: Secondary surgery should result in an improvement of the above, where the outcomes of primary surgery have been shown not to meet accepted standards. Secondary procedures like bone grafting, gingivo-periosteoplasty is done later for good cosmetics and function. Dental care and orthodontia help align the teeth and take care of any gaps that exist due to the cleft. A child with cleft palate may have trouble speaking and can make the voice nasal and difficult to understand. Some will find

that surgery fixes the problem completely. In children with velopharyngeal anomalies, surgical management includes revision of palatoplasty, pharyngoplasty, pharyngeal wall implant, palatal pushback and tonsillectomy/adenoidectomy in association with other programmed procedures. Shortly after the initial surgery is completed, the speech therapist will do complete assessment about speech and developing communication skills from 15 months of age. Emotional and social issues are to be considered and psychiatrist advice should be sought if needed.

### Postoperative Care and Follow-Up

In the immediate postoperative period, feeding care, complete pain control, wound care is essential. Subsequently during follow-up in cleft clinics, assessment of outcome and consideration for secondary procedure should be made. Speech assessment and dental alignment are essential part of programmed follow-up.

### Complications of Cleft Surgery

#### Early Complications

- Airway obstruction
- Bleeding/Haematoma
- Wound breakdown
- Necrosis of tissues
- Nerve injury
- Damage to teeth
- Infection
- Formation of excess scar.

#### Late Complications

- Abnormal dental occlusion
- Abnormal palatal morphology
- Oro-nasal fistulae
- Development of abnormal jaw relationships
- Poor acceptable function
- Abnormal facial balance
- Psychological and social problem.

### Prognosis

The outcome is good for improved facial development, improved appearance, good psychological and social acceptance and favourable speech and dental alignment.

### Prevention

Since little known about the cause of cleft lip and palate, the most sensible approach is simply to ensure a healthy pregnancy by avoiding teratogenic drugs, alcohol and smoking during pregnancy.

## BRANCHIAL ARCH ANOMALIES

Phylogenetically, the branchial apparatus is related to gill slits of fish and amphibians; hence the name 'branchial' derived from Greek for gills. Rathke in 1828 described the development of the pharyngeal arches in the human foetus.

### Embryology

At the 4th week of embryonic life, the development of the branchial or pharyngeal arches contributes to the formation of various structures between the developing head and the heart (i.e. the face, neck, oropharynx and the larynx). There are six branchial arches; the last two are rudimentary. Each arch has a bar of mesoderm. Caudal to each of the four arches is an internal pouch-lined with endoderm. Externally is branchial cleft, lined with ectoderm. Between each bar, a branchial plate, composed of endoderm and ectoderm, separates the branchial cleft from the branchial pouch. The 2nd arch grows caudally to join with 5th arch and, ultimately, covers the 3rd and 4th arches. The buried clefts become ectoderm-lined cavities, which normally involute around week 7 of development. If a portion of the cleft fails to involute completely, the entrapped remnant forms an epithelium-lined cyst with or without a sinus tract to the overlying skin.

### Pathophysiology

Branchial clefts 2, 3 and 4 fuse into one structure referred to as the cervical sinus of His created by downwards growth of the overlapping 2nd arch's ventral pole, which normally involutes completely. If a portion of the cleft fails to involute completely, the entrapped remnant forms an epithelium-lined cyst with or without a sinus tract to the overlying skin.

There are also few older theories to explain the origin of the branchial sinus. The "Inclusion Theory" suggests that the cystic alteration of cervical lymph nodes is stimulated by trapped epithelium derived from epithelial inclusions, branchial cleft, pharyngeal pouch and parotid gland. Another explanation is that it is as a result of recurrent tonsillitis and pharyngitis, leading to spread of squamous epithelium of pharynx via the lymphatic system to regional lymph nodes. Subsequent growth of this epithelium and cystic degeneration of the node forms the cyst.

### Types and Features

#### First Branchial Cleft Anomalies

First branchial cleft cysts are divided into two types: (1) type I and (2) type II. Type I cysts are located near the external auditory canal. Most commonly, they are inferior and

posterior to the tragus (base of the ear), but they may also be in the parotid gland or at the angle of the mandible. They may be difficult to distinguish from a solid parotid mass on clinical examination. Type II cysts are associated with the submandibular gland or found in the anterior triangle of the neck.

### Second Branchial Cleft Anomalies

- The second branchial cleft accounts for 95% of branchial anomalies. Second branchial cleft remnants account for the majority of branchial cleft abnormalities. Anomalies can occur anywhere along an embryologically defined tract that extends from the external opening, the anterior border of the junction of the middle and lower thirds of the sternocleidomastoid muscle, passes between the internal and external carotid arteries superficial to cranial nerves IX and XII, and enters the oropharyngeal tonsillar fossa. However, these cysts may present anywhere along the course of a second branchial fistula, which proceeds from the skin of the lateral neck, between the internal and external carotid arteries, and into the palatine tonsil.
- Fistulae of the 2nd arch would have an external opening at the anterior border of the lower third of sternomastoid because this muscle mass arises from the epicardial ridge. Further course is as described above till tonsillar fossa.

### Third Branchial Cleft Anomalies

- Third branchial cleft cysts are rare. A third branchial fistula extends from the same skin location as a second branchial fistula (recall that the clefts merge during development); however, a third branchial fistula courses posterior to the carotid arteries and pierces the thyrohyoid membrane to enter the larynx. Third branchial cleft cysts occur anywhere along that course (e.g. inside the larynx), but are characteristically located deep to the sternocleidomastoid muscle.
- A fistula formed from the 3rd branchial arch has its external opening in the same area as the second branchial fistula. The tract passes deep to the platysma, ascending along the common carotid sheath, but this time passing behind the internal carotid artery. The tract crosses the hypoglossal nerve but will not ascend above the glossopharyngeal nerve or the stylopharyngeus muscle, which are third branchial bar derivatives. The tract is superficial to the superior laryngeal nerve that supplies fourth branchial bar derivatives. The internal opening is in the pyriform sinus, the area formed from the third branchial cleft.



**Fig. 11.2:** Diagram showing the characteristic location for the outer opening and internal drainage for each of the first and second branchial cleft sinuses and fistulae

### Fourth Branchial Cleft Anomalies

- Fourth branchial cleft cysts are extremely rare. A fourth branchial fistula arises from the lateral neck and parallels the course of the recurrent laryngeal nerve (around the aorta on the left and around the subclavian artery on the right), terminating in the pyriform sinus; therefore, fourth branchial cleft cysts arise in various locations including the mediastinum.
- Fourth pouch sinuses also arise from the pyriform sinus but in contrast they course inferior to the superior laryngeal nerve. Complete fourth branchial apparatus anomalies have never been conclusively demonstrated. Theoretically, due to their site of origin, fistulae or sinus tracts originating in this branchial region would loop around the right subclavian artery on the right or the aortic arch on the left, and course superiorly to the upper oesophagus (Fig. 11.2).

### Incidence

The exact incidence in the population is unknown. There is no recognised ethnic predilection or sexual predilection recognised. Branchial cleft cysts are the most common congenital cause of a neck mass. In 2–3% of cases, it is bilateral. Approximately, 75% arise from the second cleft, 20% from the first and a few remaining from the third and fourth clefts.

### Presentation

Branchial cleft cysts are congenital in nature, but they may not present clinically until later in life, usually by early

adulthood. Many branchial cleft cysts are asymptomatic. It commonly presents as a solitary, painless mass in the neck of a child or a young adult. A history of intermittent swelling and tenderness of the lesion during upper respiratory tract infection may exist, due to the lymphoid tissue located beneath the epithelium. Spontaneous rupture of an abscessed branchial cleft cyst may occur, resulting in a purulent draining sinus to the skin or the pharynx. Discharge may be reported if the lesion is associated with a sinus tract. Depending on the size and the anatomical extension of the mass, local compressive symptoms, such as dysphagia, dysphonia, dyspnea, and stridor, may occur.

### Differential Diagnosis

- Lymphadenopathy – reactive, infective and neoplastic
- Vascular malformations
- Neoplasm
- Lymphatic malformation – cystic hygroma
- Ectopic thyroid tissue
- Ectopic salivary tissue.

### Investigations

No investigations need to be obtained in the work up of a branchial cleft cyst but if there is doubt about the diagnosis radiological investigations are required.

- In cases of sinus or fistula, especially in third and fourth branchial anomalies, sinogram or barium contrast study can delineate the course of the anomaly. Barium swallow should be performed after the resolution of acute inflammation in order to decrease the chance of false-negative results
- Ultrasonography helps to delineate the cystic nature of these lesions
- A contrast-enhanced CT scan shows a cystic and enhancing mass in the neck. It may aid preoperative planning and identify compromise of local structures
- Magnetic resonance imaging (MRI) allows for finer resolution during preoperative planning. The wall may be enhancing on gadolinium scans
- The fine needle aspiration cytology (FNAC) of the lesion can be done if there is doubt about diagnosis or high suspicion of neoplastic condition is present.

### Histologic Findings

Most branchial cleft cysts are lined with stratified squamous epithelium with keratinous debris in 90% of cases, 8% of them are composed of ciliated columnar epithelium and 2% show both types of epithelium. Usually the lumen is filled with viscid yellow fluid characteristically containing large amounts of glittering cholesterol crystals. In a small

number, the cyst is lined with respiratory (ciliated columnar) epithelium. Lymphoid tissue is often present outside the epithelial lining. Germinal centre formation may be seen in the lymphoid component, but true lymph node architecture is not seen. In infected or ruptured lesions, inflammatory cells are seen within the cyst cavity or the surrounding stroma.

### Treatment

Medical treatment: Antibiotics are required to treat infections or abscesses.

Surgical treatment: Surgery is indicated for branchial anomalies because there is a lack of spontaneous regression, a high rate of recurrent infection, the possibility of other diagnoses and rare malignant degeneration.

- Surgical excision is definitive treatment for this condition
- A series of horizontal incisions, known as stepladder incision, is made to fully dissect out the occasionally tortuous path of the cyst
- Surgery is best delayed until the patient is at least age 3 months
- Definitive surgery should not be attempted during an episode of acute infection or if an abscess is present
- Surgical incision and drainage of abscesses is indicated if present, usually along with concurrent antimicrobial therapy.

First branchial remnants are often closely associated with the facial nerve and external auditory canal. Identification and dissection of the facial nerve is a necessary step. Visualisation of the tract at operation may be aided by injecting into the fistula methylene blue dye or quick-hardening polymers. The dissection may be facilitated by prior catheterisation of the fistula.

### Complications of Branchial Cyst

- Untreated lesions are prone to recurrent infection and abscess formation with resultant scar formation and possible compromise to local structures. Rarely squamous cell carcinoma arising in a branchial cleft cyst in adults is described.
- Complications of surgical excision result from damage to nearby vascular or neural structures, which include carotid vessels and the facial, hypoglossal, vagus and lingual nerves.

### Prognosis

Following surgical excision, recurrence is uncommon, with a risk estimated at 3%, unless previous surgery or recurrent infection has occurred, in which case, it may be as high as 20%.

## THYROGLOSSAL CYST

The thyroglossal cyst is a benign midline neck mass arising from the remnant of thyroglossal duct. The cyst is usually located at the midline of the neck. It is the most common congenital neck mass. It is found in 7% population. Majority of patients are less than 10 years old. There is an equal gender distribution. They are usually asymptomatic and the majority of them occur in close proximity to the hyoid bone. Over 60% of them lie just inferior to the hyoid bone at about the level of the thyroid cartilage.

Thyroglossal cysts result from the dilatation of a remnant or failure of closure and obliteration of thyroglossal tract, which is formed during primitive thyroid descended from its origin at the base of the tongue the foramen caecum to its permanent location, low in the neck. This duct usually atrophies by about 10 weeks of development. The cysts are usually found between the isthmus of the thyroid gland and the hyoid cartilage or just above the hyoid cartilage. Of interest, about 50% of the population has a pyramidal lobe of the thyroid, and the pyramidal lobe of the thyroid is the most common remnant of the thyroglossal tract.

### Location

Thyroglossal cyst present in five different locations:

1. Infrahyoid type accounts for 65% and is mostly found in the paramedian position.
2. Suprahyoid type accounts for nearly 20% and is positioned in the midline.
3. Juxtahyoid cysts make up 15% of cases.
4. Intralingual location occurs in approximately 2% of cases.
5. Suprasternal variety occurs in approximately 10% of cases.

### Symptoms of Thyroglossal Duct Cyst

Thyroglossal duct cysts most often present with a palpable asymptomatic midline neck mass at or below the level of the hyoid bone. Some patients will have neck or throat pain, or dysphagia. Often, it presents with infection requiring drainage prior to excision or as a fistula following incomplete surgery.

On examination, the cyst rises as the patient swallows or protrudes tongue, which is the pathognomonic sign of a thyroglossal duct cyst due to its attachment to the tongue via the tract of thyroid descent and attachment to laryngeal apparatus via suspensory ligament of Berry. Often, it presents with infection requiring drainage prior to excision.

### Differential Diagnosis

The most common condition to be thought in the differential diagnosis is going to be the dermoid cyst, and next being the

pretracheal lymphadenopathy, sebaceous cysts, lymphatic malformations and uncommon cysts or masses of the neck like schwannomas and cysticercosis, etc.

### Histology

Histologically it is a well-defined cyst with an epithelial lining consisting either squamous or respiratory epithelium. Sometimes islands of thyroid tissue lying in the walls of these cysts may be seen and the cysts will usually be filled with some sort of mucous or mucopurulent material.

### Complications

Infection is probably the most common complication. It is managed with antibiotics, needle aspiration or incision drainage. If incision and drainage is done it may complicate future management by generating thyroglossal fistula with scarring and creating abnormal tissue planes, making future dissection difficult.

Carcinoma is probably the most dreaded complication of a thyroglossal duct cyst. It is extremely rare and there is excellent long-term survival. Most of these are papillary carcinoma (80–85%). About 6% of them are follicular. There have been few cases of squamous cell carcinoma in thyroglossal cysts reported in literature.

Thyroid ectopia is found in about 10% of cases and usually it is going to be in the lingual area. Patient with a thyroglossal duct cyst with the ectopic thyroid tissue may be their only source of functioning thyroid tissue. If a Sistrunk were done on this patient without knowing it, the patient would then end up in hypothyroidism, leading to myxoedema coma.

### Diagnosis of Thyroglossal Duct Cyst

Diagnosis is usually made clinically. Laboratory analysis includes a haemogram with total leucocyte count to rule out infection. Ultrasound is the gold standard for imaging and is done in almost every patient with this condition for diagnosis and to identify normal thyroid. FNAC is useful in diagnosis and to rule out other condition. Thyroid isotope scans and thyroid function studies are ordered preoperatively to demonstrate that normally functioning thyroid tissue is in its usual location.

### Treatment for Thyroglossal Duct Cyst

Treatment options:

- The definitive treatment of a non-infected thyroglossal cyst is an elective Sistrunk operation
- A thyroglossal cyst abscess requires drainage
- An infected thyroglossal cyst without abscess should be treated with antibiotics and subsequently a Sistrunk operation is done.

Sistrunk's operation consists of excision not only of the cyst but also of the path's tract and branches. The intimate association of the tract with hyoid bone mandates simultaneous removal of the central portion of the hyoid bone to ensure complete removal of the tract.

The Sistrunk's procedure does have its fair share of major complications; although uncommon, they can be fairly morbid. Recurrence is by far the most common complication of doing a Sistrunk's procedure. Hypothyroidism can also occur, as already mentioned. Also fistulae can occur and can be quite morbid and difficult to deal with when they do occur. The other major complications are abscess, airway injury, tracheotomy and nerve paralysis.

### Prognosis

Recurrence occurs in approximately 3–5% of the cases and is increased by previous incomplete excision and a history of recurrent infections.

## UMBILICAL HERNIA

An umbilical hernia is an abnormal protrusion of the abdominal lining or abdominal viscera, usually the bowel loops through a congenital weakness in the area around the navel part of the intestine and/or fluid from the abdomen.

The defect is caused by incomplete closure of the muscle of the abdominal wall at the umbilical ring, through which the umbilical blood vessels passed to provide nourishment to the developing foetus.

### Incidence

The exact incidence is unknown, but may be as high as 1 in 6 infants. Low birth weight and premature infants are also more likely to have an umbilical hernia. Boys and girls are equally affected. Umbilical hernias occur slightly more frequently in infants of African-American descent. The vast majority of umbilical hernias are not related to any disease condition. However, umbilical hernias can be associated with rare diseases such as mucopolysaccharide storage diseases, Beckwith-Wiedemann syndrome, Down syndrome and others.

### Clinical Features

A physical examination reveals the hernia. Although often appearing at or just after birth, these hernias can also occur at any time during later life. The hernia generally appears as a soft swelling beneath the skin that often protrudes when the infant is upright, crying or straining. Depending on the severity of the hernia, the area of the defect can vary in size, from less than 1 to more than 5 centimetres in diameter. Small (less than 1 cm) hernias usually close spontaneously

without treatment by age 3 to 4 years. Those that do not close may require surgery.

During examination, the contents are reduced in a calm child and the defect is assessed by passing the finger tips into the umbilical ring. This is noted so that on follow-up the reduction in size of the defect can be appreciated.

In extremely rare instances, bowel or other tissue can protrude and become strangulated due to hampering of blood flow to a section of bowel and require emergency surgery.

### Treatment

Strapping the umbilical hernia with a small tape over a suitable coin during the early months of life will cause the hernia to shrink and also disappear in 60% cases. Many umbilical hernias close spontaneously by ages 3–4. If closure does not occur by this time, surgical repair is usually advised. In younger children, only if the hernia is causing problems, enlarging, if there is an episode of incarceration or if the hernia is very large, surgical repair may be recommended. The decision for surgery should only be made after a comprehensive examination by a paediatric surgeon.

Surgery to repair the hernia is performed under general anaesthesia.

A small incision is made at the base of the belly button. If any intestine is present in the hernia, it is placed back into the abdominal cavity. The opening in the muscle is then repaired with multiple layers of stitches to prevent another hernia. A dressing is placed to keep the belly button flat.

While premature infants and children with certain medical conditions may require overnight observation in the hospital, most children are able to return home within a few hours after surgery.

### Paraumbilical Hernia

A paraumbilical hernia is one that develops around the area of the umbilicus. After birth, although the umbilical cord disappears, the weakness or gap in the muscle may persist. Hernias can occur in this area of weakness at anytime from birth through late adulthood, as the weakness progressively bulges and opens, allowing abdominal contents to protrude through. In addition to navel deformity and an associated bulge, the signs and symptoms include pain at or near the navel area.

### Follow-Up

Once the hernia is closed, it is unlikely that it will reoccur. However, the risk of recurrence is increased in patients who have wound infections following surgery or associated connective tissue disorders.

## INTUSSUSCEPTION

The disorder is characterised by telescoping of one of the portions of the intestine into a more distal portion, leading to impairment of the blood supply and necrosis of the involved segment. Of the three forms (ileocolic, ileoileal and colocolic), ileocolic is the most common. It is the most frequent cause of intestinal obstruction during the first 2 years of life.

**Aetiologic considerations:** The most common form is idiopathic and occurs classically between 4 and 7 months of age. A pathologic lead point may be found in only 2–8% of the cases, especially after 2 years of age. The predisposing factors include Henoch-Schoenlein purpura, Meckel diverticulum, parasites, constipation, inspissated faecal matter in cystic fibrosis, foreign body, lymphoma and infection with rotavirus or adenovirus.

### Clinical Features

These include episodic abdominal pain, vomiting and rectal passage of bloody mucus. Fever and prostration are usually appearing 24 hours after the onset of intussusception and signify transmural migration across congested serosa. A sausage-shaped lump may be palpable in the upper abdomen in early stages. Rectal examination may show a cervix-like mass and blood on the examining finger.

### Diagnosis

Plain X-ray abdomen may reveal absence of bowel gas in the right lower quadrant and dilated loops of small bowel.

Ultrasound will show a target sign in upper abdomen or in left iliac fossa due to presence of intussuscetum within the bowel.

Barium enema may show the intussusception as an inverted cap or a claw sign may be seen. There is an obstruction to the retrograde progression of barium into ascending colon and caecum. In the area of intussusception, there may be a ceiling-spring appearance to the column of barium.

### Treatment

Conservative hydrostatic reduction gives good results in a large majority of the cases, provided that there is no evidence of strangulation, perforation or severe toxicity. It is performed by insertion of an unlubricated balloon catheter into the rectum. The balloon is then inflated and pulled down against the levator ani muscles. Thereafter, buttocks are strapped together. From a height of 90 cm, barium is allowed to flow into the rectum. Under fluoroscopy, the progress of barium is noticed. Total reduction is judged from:

- Free flow of barium into the caecum and reflux into the terminal ileum
- Disappearance of the lump

- Passage of flatus and/or stools per rectum
- Improvement in the patient's general condition
- Passage of charcoal, placed in child's stomach by the nasogastric tube, per rectum.

Surgical/reduction is indicated in patients who are unfit for hydrostatic reduction or who fail to respond to hydrostatic reduction after 2 attempts.

### Prognosis

Left unreduced, intussusception is invariably fatal. Spontaneous reduction with recurrent episodes is known in older children.

## SURGICAL JAUNDICE IN CHILDREN

Yellow discolouration of the skin and the sclera of the eyes and body fluids due to increased level of bilirubin is called as jaundice. Jaundice is a common problem in paediatric age group. The common clinical problems are neonatal jaundice and viral hepatitis. Neonatal jaundice affects 60% of full-term infants and 80% of preterm infants in the first 3 days after birth. Although transient and self-limiting in most of the cases but some cases may be due to pathological reason. This section mainly aims to provide a bird eye view about the physiology of bilirubin metabolism, causes of jaundice in children and emphasis on the common neonatal surgical jaundice, e.g. biliary atresia (BA) and its management.

### Bilirubin Metabolism

Bilirubin, a by-product of the breakdown of haemoglobin (the oxygen-carrying substance in red blood cells), is produced when the body breaks down old red blood cells. Bilirubin is a by-product of haem catabolism. In the neonate, destruction of senescent erythrocytes accounts for 75% of the bilirubin produced. Almost completely insoluble in water, bilirubin must be bound to albumin for transport in the plasma. Bound bilirubin coexists with a small-unbound fraction determined by both the molar ratio of albumin to bilirubin and the binding affinity of albumin. Bilirubin is conjugated to glucuronic acid in the liver in a reaction catalysed by uridine diphosphate glucuronyl transferase (UDPGT). The bilirubin glucuronide, which is water-soluble, is secreted by active transport into the bile canaliculi and becomes concentrated in the gallbladder before excretion into the intestinal tract. In the intestine, some of the bilirubin glucuronide can be deconjugated to water-insoluble unbound bilirubin, which readily enters the enterohepatic circulation. Deconjugation and resorption of bilirubin is minimal in adults, due to the action of intestinal bacteria, which progressively convert the bilirubin glucuronide into water-soluble stercobilins and urobilins that are excreted in the stool.

## Physiologic Jaundice

Jaundice in healthy, full-term newborns has been termed physiologic because hyperbilirubinaemia occurs universally in neonates. Before birth, an infant gets rid of bilirubin through the mother's blood and liver systems. After birth, the baby's liver has to take over processing bilirubin on its own. Almost all newborns have higher than normal levels of bilirubin. In most cases, the baby's systems continue to develop and can soon process bilirubin. However, some infants may need medical treatment to prevent serious complications, which can occur due to the accumulation of bilirubin.

Total serum bilirubin concentration usually peaks at 5–12 mg/dl on the second or third day after birth. In newborns, the activity of UDPGT is limited due to immaturity of the liver enzyme system. At birth, the UDPGT activity level is only 0.1–1% that of the adult. Activity increases overtime but does not reach adult levels until 6–14 weeks after birth. As a result, bilirubin accumulates. Infants lack intestinal bacterial flora, very little bilirubin glucuronide is converted to stercobilins and urobilins, with the result that both conjugated and unconjugated bilirubin are excreted as the golden-yellow pigment characteristic of the stools of the newborn. Jaundice should be considered non-physiologic or pathologic, if it occurs less than 24 hours after birth, if bilirubin levels rise at a rate of greater than 0.5 mg/dl per hour or 5 mg/dl per day, if total bilirubin levels exceed 15 mg/dl in a full-term infant or 10 mg/dl in a preterm infant, if evidence of acute haemolysis exists, or if hyperbilirubinaemia persists beyond 10 days in a full-term infant or 21 days in a preterm infant. (However, mild breast-milk jaundice may persist for up to 2 weeks in breast-fed infants).

## Kernicterus

Severe hyperbilirubinaemia could result in kernicterus. This condition is characterised by bilirubin staining of the basal ganglia and involves diffuse neuronal damage, which results in severe neurologic sequelae. Kernicterus rarely occurs with unconjugated bilirubin levels lower than 20 mg/dl (340  $\mu$ mol/L) but typically occurs when levels exceed 30 mg/dl. When levels are between 20 and 30 mg/dl, concomitant conditions such as prematurity and haemolytic disease may increase the risk of kernicterus.

Clinically, bilirubin encephalopathy progresses through three phases. In the first 2–3 days the infant is lethargic and hypotonic and sucks weakly. Progression is marked by hypertonia (especially of the extensor muscles), arching, opisthotonic posturing, fever, seizures and high-pitched crying. In the final phase, the patient is hypotonic for several days and then gradually becomes hypertonic. Affected

children have marked developmental and motor delays in the form of choreoathetoid cerebral palsy. Mental retardation may also be present. Other sequelae include extrapyramidal disturbances, auditory abnormalities, gaze palsies and dental dysplasia.

## Diagnosis

The initial diagnosis of hyperbilirubinaemia is based on the appearance of jaundice at physical examination. The child is often placed by an open window so he/she may be checked in natural light. Blood samples may be taken to determine the bilirubin level in the blood.

## Treatment

Most cases of newborn jaundice resolve without medical treatment within 2–3 weeks, because most often it is due to physiologic jaundice. It is important that the infant is feeding regularly and having normal bowel movements. If bilirubin levels are high, the infant may be treated with phototherapy exposure of the baby's skin to fluorescent light. The bilirubin in the baby's skin absorbs the light and is changed to a substance that can be excreted in the urine. This treatment can be done in the hospital and is often done at home with special lights, which parents can rent for the treatment. Treatment may be needed for several days before bilirubin levels in the blood return to normal. The baby's eyes are shielded to prevent the optic nerves from absorbing too much light. Another type of treatment used is a special fiberoptic blanket. There is no need to shield the baby's eyes with this treatment, and it can be done at home. Light emitted at a wavelength of 425–475 nm converts bilirubin to a water-soluble form that can be excreted in the bile or urine without glucuronidation.

Multiple factors can influence the effectiveness of phototherapy, including the type and intensity of the light and the extent of skin surface exposure. "Special blue" fluorescent light has been shown to be most effective, although many nurseries use a combination of daylight, white and blue lamps. Recently, fiberoptic blankets have been developed that emit light in the blue-green spectrum. These are effective, convenient forms of phototherapy. The intensity of light delivered is inversely related to the distance between the light source and the skin surface.

Phototherapy acts by altering the bilirubin that is deposited in the subcutaneous tissue. Therefore, the area of the skin exposed to phototherapy should be maximised. This has been made more practical with the development of fiberoptic phototherapy blankets that can be wrapped around an infant. Double phototherapy can reduce bilirubin levels twice as fast as single phototherapy and can be accomplished by using the combination of a blanket and a bank of lights or by using two banks of lights.



## Biliary Atresia

Biliary atresia is a rare disease characterised by a biliary obstruction of unknown origin that presents in the neonatal period. It is the most important surgical cause of cholestatic jaundice in this age group. The common histopathological picture is one of inflammatory damage to the intrahepatic and extrahepatic bile ducts with sclerosis and narrowing or even obliteration of the biliary tree. Untreated, this condition leads to cirrhosis and death within the first year of life. Surgical treatment usually involves an initial attempt to restore bile flow: the Kasai portoenterostomy, which is performed as soon after diagnosis as possible. Later, liver transplantation may be needed for failure of the Kasai's operation or due to complications of cirrhosis. BA remains the commonest indication for paediatric liver transplantation throughout the world. The reported incidence of BA varies from 5/1,00,000 live births.

### Aetiology

The aetiology of BA remains unknown. Some cases seem to be related to abnormal morphogenesis of bile ducts occurring early in gestation, while others appear to arise as a result of later perinatal damage to normal developed bile ducts. The role of viruses has been extensively studied. An association of BA with cytomegalovirus, respiratory syncytial virus, Epstein-Barr virus and human papilloma virus has been reported, and alternatively, no association has been found with hepatitis A, B and C viruses. Reovirus type 3 can cause cholangitis resembling BA in mice and may be associated with spontaneous BA in the rhesus monkey. In human neonates, the association of reovirus type 3 and BA has been suggested in several studies but not supported in others. A strictly genetic cause is unlikely although familial cases of BA have been reported. BA is associated with various congenital anomalies such as polysplenia, asplenia, cardiac or intra-abdominal defects (situs inversus, preduodenal portal vein, absence of retrohepatic inferior vena cava, intestinal malrotation).

### Types of Biliary Atresia

- Type 1: Atresia limited to common bile duct (CBD) (3%)
- Type 2: Gallbladder, cystic duct and CBD patent (25%)
- Type 3: Complete extrahepatic biliary atresia at the level of porta hepatis (72%).

### Clinical Features

The clinical triad of BA is jaundice (conjugated, and beyond 2 weeks of life), acholic (white) stools and dark urine and hepatomegaly. The general condition of the child is usually

good and at least initially there is no failure to thrive. Later signs include splenomegaly (suggesting portal hypertension), ascites and haemorrhage (which can be intracranial, gastrointestinal or from the umbilical stump and is due to impaired absorption of vitamin K).

### Investigations

#### Ultrasonography

On ultrasonography BA is suspected if the gallbladder is shrunken despite fasting, if the liver hilum appears hyperechogenic ("triangular cord sign"), or if there is a cyst at the liver hilum. There should be no evidence of bile duct dilatation. Syndromic BA infants may show other features such as multiple spleens, a preduodenal portal vein, absence of the retrohepatic vena cava, etc.

#### Hepatobiliary Scintigraphy (HIDA Scan)

It demonstrates failure of excretion of the radioisotope into the intestine. Hepatobiliary scintigraphy using iminodiacetic acid (IDA) radiopharmaceuticals provides clinically useful information on the function of the biliary tract. Phenobarbital premedication (5 mg/kg per day for a minimum of 5 days in divided doses) is used in infants who are being examined for neonatal jaundice to increase the accuracy of <sup>99m</sup>Tc-IDA scintigraphy in differentiating extrahepatic BA from neonatal hepatitis. BA can be ruled out in an infant if a patent biliary tree is shown with passage of activity into the bowel. If no radiopharmaceutical is noted in the bowel on imaging up to 24 hours but with good hepatocyte function it is suggestive of obstruction of biliary tree. HIDA scan can rule out BA if there is excretion.

#### Magnetic Resonance Cholangiopancreatography (MRCP)

Magnetic resonance imaging of the hepatobiliary tree gives an idea about the anatomy of the biliary tree and identifies a choledochal cyst. It is non-invasive but availability and need for sedation for newborn is an issue.

#### Cholangiography

In the cases where the gallbladder seems normal on US scans, cholangiography is needed to assess the morphology and patency of the biliary tree. The cholangiogram can be performed by open operative technique.

#### Liver Biopsy

The main features suggesting BA are bile plugs, ductular proliferation, portal oedema and/or fibrosis. As in any other cause of neonatal cholestasis, giant cell transformation may be observed.

#### Other Tests

Biochemical liver function tests show cholestasis (with elevated liver enzymes and gamma glutamyl transferase).

## Management

The current management of BA patients involves Kasai's operation, which aims to restore bile flow by excising the atretic extrahepatic biliary tree and anastomosing small bowel to the portal hilum to maintain bile flow. The important steps of the operation are after section of the falciform, left and right triangular ligaments; the liver is exteriorised out of the abdominal cavity. The entire extrahepatic biliary tree is excised together with the fibrous tissue situated inside the bifurcation of the portal vein at the level of the porta hepatis. A 45 cm Roux-en-Y loop is prepared and passed through the mesocolon to the liver hilum. An anastomosis is fashioned between the cut edge of the transected tissue in the porta hepatis and the antimesenteric side of the Roux-en-Y loop. A liver biopsy is performed. The following are the complications of BA as such and Kasai's operation.

## Postoperative Complications

### Early Postoperative

- Fluid and electrolyte imbalance
- Bleeding diathesis
- Hepatorenal syndrome
- Absence of bile drainage
- Anastomotic leak
- Burst abdomen
- Persisting ascitic leak
- Hepatic encephalopathy.

### Late Complications

- Diet and nutrition problem
- Physical, mental and sexual dysfunction
- Pruritus
- Ascites
- Adhesive obstruction
- Anastomotic stricture
- Recurrent cholangitis
- Progressive cirrhosis
- Portal hypertension
- Hepatopulmonary syndrome and pulmonary hypertension
- Malignancies
- Progressive disease needing transplantation of liver.

Patients who present late with failing liver function or those who develop progressive liver damage after Kasai's operation need liver transplantation to save the life. BA is the commonest indication for liver transplantation in children.

## BIBLIOGRAPHY

1. Gastroenterology series of MONOGRAPHS and textbook—Extrahepatic Biliary Atresia, Fredric Daum, 1983.
2. John P. Cloherty, Eric C. Eichenwald, Ann R. Stark. Manual of Neonatal Care, 5th edition. Lippincott Williams Company;2003.

3. Keith W. Ashcraft (Ed). Pediatric Surgery, 3rd edition. WB Saunders Company;2000.
4. Gupta DK (ED). Textbook of Neonatal Surgery, 1st edition. Modern Publishers;2000.

## CHOLEDOCHAL CYST

### Introduction

The term choledochal cyst is derived from chole—relating to bile; dochal—containing, receiving or duct; cyst—fluid collection. Choledochal cyst is considered as congenital problem of the bile ducts characterised by abnormal permanent cystic dilatations of the extrahepatic biliary tree, intrahepatic biliary radicles or both.

The first script about choledochal cyst was published by Vater and Ezler in 1723. Douglas made first clinical report in a 17-year-old girl who presented with classical symptoms. Alonso-Lej et al made detailed description of choledochal cysts in 1959. The classification system for choledochal cysts was further refined by Todani et al. in 1977 and currently includes five major types and it is followed till now.

### Types of Choledochal Cysts

Depending on the location and type of choledochal cysts they can be classified into five types by Todani classification, which is described below.

**Type I choledochal cysts:** Constitute 80–90% of the lesions. It is characterised by dilatations of the entire common hepatic and CBDs or segments of each. They can be saccular or fusiform in configuration. In this form of abnormality, the gallbladder usually enters the choledochal cyst itself, which is really a dilated CBD. The right and left bile ducts and the ducts within the liver are usually normal in size in these instances.

**Type II choledochal cysts:** It is characterised by isolated protrusions or diverticulum (outpouching) that project from the CBD wall although the CBD itself is normal. They may be sessile or may be connected to the CBD by a narrow stalk.

**Type III choledochal cysts:** It is characterised by cystic dilatation of the intraduodenal portion of the CBD. There is some degree of narrowing or blockage in the distal end of CBD. Another term used for these cysts is choledochocoele.

**Type IV choledochal cysts:** It is characterised by dilation of biliary ducts within the liver and also outside the liver. There are two types of type IV choledochal cysts.

- (1) Type IVA choledochal cysts are characterised by multiple dilatations of the intrahepatic and extrahepatic biliary tree. Most frequently, multiple cysts of the intrahepatic ducts accompany a large solitary cyst of the extrahepatic duct.

(2) Type IVB choledochal cysts consist of multiple dilations that involve only the extrahepatic bile duct.

**Type V choledochal cysts:** This type is characterised by dilatation of the intrahepatic biliary radicals only with normal bile duct system outside the liver. Often, numerous cysts are present with interposed strictures that predispose the patient to intrahepatic stone formation, obstruction and cholangitis. The cysts are typically found in both hepatic lobes. Occasionally, unilobar disease is found and most frequently involves the left lobe.

### Aetiology

The aetiology of choledochal cyst in its various forms of presentation is not precisely known. However, the so-called “common channel theory” stands out as the most likely explanation. In almost all instances of choledochal cyst there is an abnormal arrangement of the pancreatic and bile duct junction in which the junction is high above the level of the muscle in the wall of the duodenum, which controls the direction of flow within these ducts. With an abnormal pancreaticobiliary duct junction, there is free-flow of pancreatic juice into the CBD extending up to the level of the liver. In the foetus, some of the digestive enzymes in pancreatic juice may damage the wall of the forming CBD resulting in duct dilation (enlargement) and a downstream blockage. The reason for the abnormal pancreaticobiliary junction seen in patients with choledochal cyst is likely to be based on genetic or hereditary factors. Additionally, choledochal cysts and bile duct abnormalities are much more common in oriental than in other populations, another suggestion that hereditary factors are involved. On the other hand, these abnormalities do not tend to run in families from one child to the next, so multiple factors must be involved. The large number of females is suggestive of a sex-linked genetic problem.

### Clinical Presentation

It is common in persons of Asian ancestry, especially those of Japanese origin. Choledochal cysts are more prevalent in females. The female-to-male ratio is approximately 3:1–4:1.

Approximately 70% of paediatric patients with choledochal cysts have signs or symptoms related to the cyst before they are aged 10 years. A choledochal cyst may not become clinically apparent until the patient is an adult. In many adult patients, sub clinical bile duct inflammation and biliary stasis have been ongoing for years. Adults with choledochal cysts can present with hepatic abscesses, cirrhosis, recurrent pancreatitis, cholelithiasis and portal hypertension.

The clinical history and presentation of a patient with a choledochal cyst varies with the patient’s age. Overt dramatic

signs and symptoms are more common in infancy, whereas manifestations are more subtle and protean in adulthood.

Infants frequently come to clinical attention with jaundice and the passage of acholic stools. These infants present with a clinical picture of complete bile duct blockage and jaundice. Numerous infants have been noted to have a choledochal cyst *in utero* on prenatal ultrasound, but following birth it appears that jaundice takes 1–3 weeks to become evident if this presentation occurs in early infancy, a work up to exclude BA may be initiated. Infants with choledochal cysts can have a palpable mass in the right upper abdominal quadrant; this may be accompanied by hepatomegaly.

Children in whom the condition is diagnosed after infancy present with a different clinical constellation, which includes intermittent bouts of biliary obstructive symptoms or recurrent episodes of acute pancreatitis. Children in whom biliary obstruction is present may also have jaundice and a palpable mass in the right upper quadrant. The correct diagnosis is occasionally more difficult in children with pancreatitis. Often, the only clinical symptoms are intermittent attacks of colicky abdominal pain. Biochemical laboratory values reveals elevations in amylase and lipase levels. This leads to the proper diagnostic imaging work up.

The so-called adult form of choledochal cyst presents with frequent complaints of vague epigastric or right upper quadrant abdominal pain, jaundice, and occasionally a soft mass can be felt in the right upper area of the abdomen. Indeed, the most common symptom in adults is abdominal pain. A classic clinical triad of abdominal pain, jaundice, and a palpable right upper quadrant abdominal mass has been described in adults with choledochal cysts, although this is found in only 10–20% of patients. Cholangitis can be part of the clinical presentation in adult patients with biliary obstruction.

### Complications

Choledochal cysts not appearing until adulthood can be associated with a number of serious complications resulting from long-standing biliary obstruction and recurrent bouts of cholangitis. Other complications include cholelithiasis, severe pancreatitis, hepatic abscesses, cirrhosis, and portal hypertension. The poor drainage causes infections in the bile duct in many patients. Some patients develop repeated attacks of pancreatitis since the pancreatic duct may enter into the bile duct with abnormal junction. If the cyst is not removed at the time of surgery then this exposes the patient to future development of bile duct cancer in the wall of the cyst. The most worrisome complication of choledochal cysts is cholangiocarcinoma. The reported rate of this malignancy in patients with choledochal cysts is 10–30%. The incidence of cancer in a choledochal cyst is 20 times greater than in the

general population. About 20% of the adult population with a choledochal cyst will develop cancer in a cyst if the cyst is not removed. By the age of 50 years up to 50% of patients will have cancer in the cyst.

## Diagnosis

### *Blood Tests*

No blood test is specific for the diagnosis of choledochal cyst; further studies indicate the status of the patient and any possible complications. Since the most common sign of a choledochal cyst is jaundice, the main finding is an increase in bilirubin in the blood. At times, in cases of severe cholangitis or long-standing biliary blockage, patients may show signs of a decrease in blood clotting.

### *Radiological Imaging*

The only sure way to diagnose a choledochal cyst is some form of radiological study. As mentioned previously, prenatal ultrasound frequently identifies a choledochal cyst that may be present in the foetus. Immediately following birth, the most helpful initial screening study is abdominal ultrasound since this study is capable of showing the entire bile duct system within and outside the liver, the gallbladder and the pancreas.

Most people feel that in the newborn with jaundice and an enlarged biliary tree outside the liver shown on ultrasound, no further diagnostic studies are required preoperatively. In addition to ultrasound examination in the newborn, some physicians also like to obtain a nuclear medicine scan or a CT scan.

Because of the subtle clinical presentation of most older children, this age group may require additional studies, particularly due to the intermittent nature of jaundice seen in this age group. In older patients, injections of the bile duct system with dye (contrast) either through the skin or by means of a scope placed in the duodenum while performing X-rays or special MRI techniques may be needed.

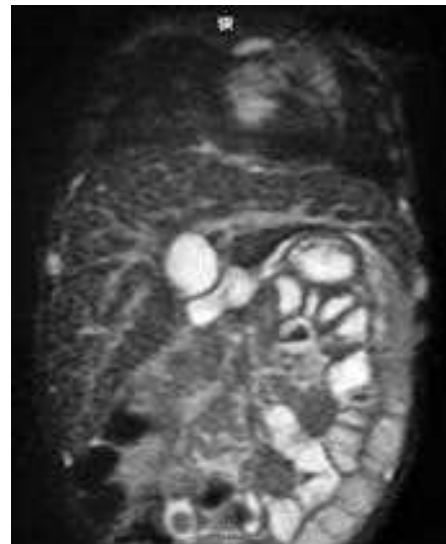
In addition to demonstrating the common channel frequently seen in these patients, these studies are particularly useful for defining the precise anatomy so that planning an appropriate operation can be undertaken. At the time of an operation, X-rays using a contrast injection directly into the bile duct system (operative cholangiogram) are usually performed in order to confirm all of the preoperative findings. It usually does not take very long to obtain all of the preoperative information necessary to plan operative correction. While diagnostic studies are being accumulated, measures are undertaken to make sure the patient is in the best possible preoperative condition. Antibiotics are usually a part of this preparation.

Ultrasound is non-invasive, it involves no radiation exposure, and its findings are sensitive and specific for the diagnosis. Patients with choledochal cysts most often have symptoms referable to the hepatobiliary system, and most US operators are familiar with the anatomy of this area.

Abdominal US findings can help in detecting associated conditions and complications of choledochal cysts, such as choledocholithiasis, intrahepatic biliary dilatation, portal vein thrombosis, gallbladder or biliary neoplasms, pancreatitis and hepatic abscesses; other supportive studies may be ordered, including abdominal CT, MRI or MRCP examinations. These studies demonstrate the cyst with more precise anatomic detail. In addition, important anatomic relationships to surrounding structures are better defined than with other modalities (Fig. 11.3).

CT scans of a choledochal cyst demonstrate a dilated cystic mass with clearly defined walls, which is separate from the gallbladder. The fact that this mass arises from or actually is the extrahepatic bile duct usually is clear from its location and its relationships to surrounding structures. The cyst is typically filled with bile, which produces water-like attenuation. Depending on the patient's age and clinical history, the wall of the cyst can appear thickened, especially if multiple episodes of inflammation and cholangitis have occurred.

Use of MRI and MRCP techniques is increasing dramatically for the non-invasive diagnosis of biliary and pancreatic diseases. Choledochal cysts are no exception. These cysts appear as large fusiform or saccular masses that may be extrahepatic, intrahepatic or both, depending on the type of cyst. They produce a particularly strong signal on



**Fig. 11.3:** Magnetic resonance cholangiopancreatography showing choledochal cyst

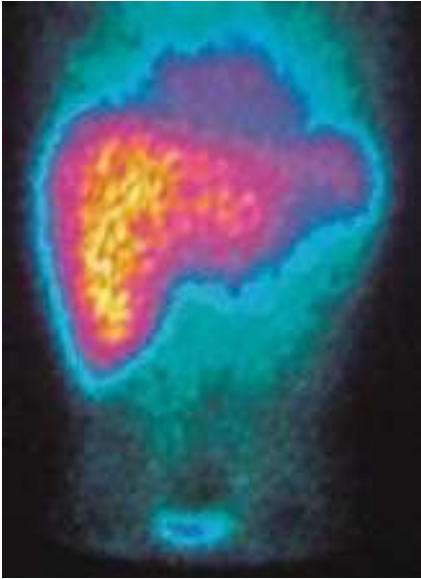


Fig. 11.4: HIDA scan showing filling defect due to choledochal cyst

T2-weighted images. Associated anomalies of the pancreatic duct, its junction with the CBD, and the long common channel formed by the two are usually well demonstrated on MRI/MRCP images.

Hepatobiliary scintigraphic modalities are used commonly in the setting of acute cholecystitis and in the investigation of neonatal jaundice. In addition, these techniques are useful in the diagnosis of choledochal cysts (Fig. 11.4).

Non-visualisation of the gallbladder in children is not necessarily indicative of acute cholecystitis and that large choledochal cysts may compress the gallbladder, leading to non-visualisation.

### Treatment

The only effective treatment is surgical correction, other measures only serve the purpose to maximise the patient's condition before operation.

The treatment for choledochal cysts is surgical. The preferred procedure today is to completely remove (excise) the dilated duct system outside the liver and to drain the CBD as it exits the liver into a loop of intestine designed to prevent backflow of intestinal contents into the liver, thus protecting the patient from cholangitis. As long as no blockage occurs at the level of the suture line between the bile duct system and the intestine, these patients do very well for long-term.

The treatment of choice for a type I choledochal cyst is complete excision of the cyst with construction of a Roux-en-Y biliary-enteric anastomosis to restore biliary continuity with the gastrointestinal tract.

Type II choledochal cysts can usually be excised entirely, and the defect in the CBD can be closed primarily over a

T-tube. This approach can be used because, typically, type II choledochal cysts are lateral diverticulum of the bile duct.

Therapy for type III choledochal cysts or choledochocoeles, depends on the size of the lesion. Choledochocoeles with a diameter of 3 cm or smaller may be approached endoscopically and effectively treated by means of sphincterotomy. Choledochocoeles larger than 3 cm in diameter are often associated with some degree of duodenal obstruction. These cysts can be excised surgically if feasible.

For type IV choledochal cysts, the dilated extrahepatic duct is completely excised, and a Roux-en-Y biliary-enteric anastomosis procedure is performed. No therapy is specifically directed at the intrahepatic ductal disease, except if intrahepatic ductal strictures, hepatolithiasis or hepatic abscesses are present. In these patients, interventional radiological techniques can be performed. If the disease is limited to specific hepatic segments or a lobe, these may be resected.

A type V choledochal cyst or Caroli disease is defined only by the dilatation of the intrahepatic ducts. If dilatation is limited to a single hepatic lobe, usually the left, the affected lobe is resected. Patients who have bilobar disease and signs of biliary cirrhosis, portal hypertension or liver failure may be candidates for liver transplantation.

### BIBLIOGRAPHY

1. Paediatric Surgery: Diagnosis and Management. In: Gupta DK, Sharma S, Aziz Khan RG (Eds). New Delhi: Jaypee Brothers Medical Publishers; 2008.

### INGUINAL HERNIA AND HYDROCOELE

It is the protrusion of the abdominal viscous into a peritoneal sac (the processus vaginalis) in the inguinal canal (Fig. 11.5). The contents of the sac are usually intestine but may be omentum, Meckel's diverticulum, and ovary and fallopian tube in girls. The incidence of paediatric inguinal hernia is between 0.8% and 4.4%. The male:female ratio is 6:1. The patent processus vaginalis (without a hernia) is present in 80% of boys at birth, in 40% at 2 years and in 20% of adult men.

Conditions that may predispose to the development of congenital inguinal hernia include undescended testis, bladder exstrophy, ascites, ventricular peritoneal shunt, peritoneal dialysis, repair of exomphalos or gastroschisis, meconium peritonitis, cystic fibrosis and connective tissue disorders.

In children it is almost always an indirect inguinal hernia (hernial sac originating lateral to the deep epigastric vessels) unlike the direct one (medial to the same vessels) seen in adults. Most of the inguinal hernias are apparent and present before 6 months of age. However, many a times there is only a history provided by the parents of the swelling that appears



**Fig. 11.5:** Bilateral inguinal hernia

in the inguinal region, especially when the child cries. The swelling disappears when the child is either calm or goes to sleep. A reliable history is usually enough to establish the diagnosis, although there is no evidence of such an anomaly when the baby is presented for examination.

### Diagnosis

On physical examination, cough or cry impulse is the most important sign. A soft bulge that is reducible on digital pressure is also a diagnostic feature. Hernia in neonates may be transilluminant so it is not a very reliable test to differentiate it from hydrocoele.

The spermatic cord may feel thickened or “rustle” on palpation, as the contiguous folds of the peritoneum slide over one another (“silk glove” sign). Confusion may occur if there is an undescended testis in the inguinal region. A hydrocoele shows brilliant transillumination, is irreducible and its upper limit is identifiable distal to the external ring. On eliciting history, a hydrocoele fills from below upwards while an inguinal hernia appears from above downwards. An encysted hydrocoele of the cord may mimic as an irreducible indirect inguinal hernia, but can be distinguished by traction on the testis: the encysted hydrocoele will move up and down while an incarcerated hernia is immobile at the external inguinal ring. Hydrocoeles have a light blue colour through the skin, while meconium peritonitis with meconium or blood in the processus will look black or dark blue. Neonatal hydrocoeles are rarely very tense, and the testis within can be felt or at least transilluminated, to confirm its normalcy. Other differential diagnoses include testicular torsion, lymphadenitis and torsion of the testicular appendices in which the blue dot sign is apparent at the upper

pole of the testis. Needle aspiration is contraindicated in inguinal swelling for the fear of perforating the intestines.

### Treatment

Once confirmed, inguinal hernias never regress and all inguinal hernias would need surgical repair as and when diagnosed. In the Western world, the premature infants with hernia are not discharged unless the hernia has been repaired, as the chances of incarceration are very high. For this, an expert paediatric anaesthetist is required, as anaesthesia risks may be higher. Postoperative apnea is also common in premature babies and at times may even require ventilatory support. In the developing countries, as the facilities for anaesthesia and the postoperative support for the premature babies and the newborns are very limited, hence all such babies should either be referred to a higher centre or the surgery be deferred till the risk of anaesthesia is low.

There should not be any undue delay in deciding in favour of surgery as the spontaneous disappearance of inguinal hernia does not occur, risk of incarceration is greater in infants, and the operation is simple with almost 100% success. However, the surgery is technically more difficult and the risk of injury to the vas and testicular vessels is greater in long-standing and incarcerated hernias.

### Herniotomy

Herniotomy is performed through an incision in the lower most transverse inguinal skin crease. In neonates, the inguinal canal is not developed and the external inguinal ring lies over the internal inguinal ring so the incision is limited to the medial portion of the skin crease. The sac is identified after splitting the cremasteric muscles, the contents are reduced and the sac is transfixed high at the level of the internal inguinal ring. Herniorrhaphy (repair of the inguinal canal) is not required in children as the posterior wall is normal and strong enough. Bilateral repair can easily be done at the same time and should ideally be done in all patients presenting with bilateral hernias.

In infants under the age of one year, the contralateral sac is present in about 50% of cases. The issue of contralateral exploration in an ipsilateral hernia is debatable and the opinion varies from centre to centre. Direct inguinal hernia and femoral hernia require Cooper's ligament repair in addition to the ligation of the sac.

### Irreducible Hernia

If not treated surgically, inguinal hernias are known to get complicated with obstruction and even strangulation. It occurs when the intestine gets stuck at the internal inguinal ring. If it is prolonged, the blood supply may also get hampered to cause strangulation. There is a sudden increase in the size

of the hernia with severe pain and the symptoms of bowel obstruction appear (vomiting and abdominal distension). On examination, a hard, tender and a fixed mass in the groin is palpable with increased bowel sounds on auscultation. It may be confused with the torsion of testis, acute inguinal lymphadenitis and tense infected hydrocoele. The treatment for the obstructed (without vascular compromise) inguinal hernias includes: an adequate sedation and administration of the analgesics to calm the baby, cold fomentation (to reduce the oedema and a gentle pressure is applied to reduce the hernial contents). It is contraindicated if the signs of peritonitis are present.

After reduction of the hernia the child should be admitted to the hospital and checked hourly to be sure that the damage to the intestine or testis has not occurred and also to reduce a recurrent incarceration promptly if it occurs. Herniotomy is performed preferably after 48 hours when the tissue oedema has subsided. In cases of irreducible and strangulated hernias, an urgent surgical exploration is mandatory.

### Postoperative Complications

- Scrotal swelling—fluid accumulation may occur but it resolves spontaneously
- Ascending testis—iatrogenic undescended testis
- Recurrence rate up to 20% has been reported in incarcerated hernias
- Injury to the vas deferens. This may be avoided by not holding the vas directly with the forceps and assuring its position during ligation of the sac
- Testicular atrophy—it may occur in incarcerated hernia
- Intestinal injury has been reported in association with incarcerated hernia
- Mortality may be related to prematurity and cardiac disease.

### Hydrocoele

It is formed due to the accumulation of fluid in the scrotum due to persistent communication via a patent processus vaginalis from the peritoneal cavity (Fig. 11.6). Rarely, it is secondary to epididymo-orchitis, tumour or torsion of testis. It is usually asymptomatic, but large sized hydrocoeles cause not only dragging pain but also likely to get infected. Trauma may also occur to the sac with formation of haematocoele. In all such cases, the testis is not palpable separately. The upper pole of the swelling is easily reachable. It reduces gradually on lying down for long and is transilluminant (hernia is a



Fig. 11.6: Right hydrocoele

neonate may also be transilluminant). There is no cough impulse present. Left-sided hydrocoeles are more common as it takes longer for the left processus vaginalis to close down and thus it remains patent with the peritoneal cavity.

The condition needs to be differentiated from inguinal hernia and the underlying pathologies like tumours and torsion of the testis should not be missed. Spermatocoele and varicocoele are non-transilluminant, have worm like feeling on palpation and is separate from the testes.

Surgical treatment is rarely indicated as most cases would have spontaneous resolution as the child grows and the processus vaginalis closes. However, surgery is always indicated in all those cases of hydrocoeles that do not disappear by the age of 2 years, hydrocoeles that appear de Novo, i.e. those which appear afresh in infancy and also those which are larger and symptomatic. The surgical procedure is a simple herniotomy (closure of the communication from the peritoneal cavity) as is done for inguinal hernia, with no attempt to excise the sac completely.

### BIBLIOGRAPHY

1. Gupta DK. Common surgical problems in children. In: Gupta DK (Ed). Textbook of Neonatal Surgery. New Delhi: Modern Publishers; 2000 pp. 109-17.
2. Gupta DK, Rohatgi M. Inguinal hernia in children: an Indian experience. *Pediatr Surg Int.* 1993;8:466-8.
3. Gupta DK, Sharma S. Common Inguinoscrotal Problems in Children, in *Recent Advances in Surgery*. Roshal Lal Gupta (Ed). 2006.pp. 147-61.

# Paediatric Urology

## HYDRONEPHROSIS

Hydronephrosis reflects an aseptic dilatation of the pelvicalyceal system as a result of a functional or mechanical obstruction at pelviureteric junction (PUJ) or somewhere distally. PUJ obstruction is the most common cause of hydronephrosis, discovered antenatally on ultrasound or presenting later in childhood. If left untreated, complications may lead to progressive renal insufficiency.

### Hydrodynamics

Urine passes from renal pelvis into ureter by anatomical continuity at the PUJ and peristaltic contractions from pelvis to ureter. Normal basal pressure in the renal pelvis varies from 5 to 25 cm of water. An obstruction causes initial rise in pressure leading to dilatation. This results in fall of renal pressure and the equilibrium is maintained for long without symptoms and the renal damage is slow.

### Aetiology

- Idiopathic obstruction—intrinsic abnormality due to muscle defect
- Angulation and adhesions at PUJ
- Aberrant vessels (20%)
- Ureteral stenosis/hypoplasia
- Polyp, papilloma and valve in the ureter at PUJ
- Persistent foetal ureteral folds
- Secondary PUJ due to vesicoureteric reflux (VUR) (5–10%): Reflux increases urine load on ureter and pelvis leading to dilatation, onset of infection leads to periureteritis fibrosis—true obstruction.

### Clinical Presentation

Patients with congenital hydronephrosis due to PUJ may remain asymptomatic throughout their life. However, they may develop symptoms at any stage depending on the degree and duration of obstruction.

- Renal lump—unilateral/bilateral, tense cystic/soft, small/large
- Pain—high pressure, acute obstruction, infection, stone
- Infection, stone—rare and requires to rule out VUR/obstruction
- Acute presentation—intermittent lump, nausea, vomiting (Dietl's crisis)
- Haematuria—rare, usually after trauma
- Renal failure—usually in single kidney with PUJ
- General features—failure to thrive, anaemia
- Chance finding—antenatal, postnatal on ultrasound/intravenous urogram or intravenous pyelogram (IVU or IVP).

### Investigations

- Routine haemogram, renal biochemistry
- Urine examination—microscopy and culture
- Ultrasonography (USG)—first modality for anatomical dilatation. It is mainly operator dependent. It is a good screening modality of first choice, noninvasive and can detect ureteric dilatation/bladder or urethra pathology also. It is also helpful to assess the other kidney and differentiate hydronephrosis from other lumps—tumors, multicystic kidney and multilocular cysts. It is useful for diagnosis of antenatal hydronephrosis
- Nuclear imaging—diuretic renogram (DTPA) for function, clearance and glomerular filtration rate (GFR). Diuretic renogram is useful for differentiating the obstructed from nonobstructed system and provides individual renal function. It is now the ideal investigation for screening and for follow-up evaluation. The grading on the diuretic scan is normal function, if function is 40% or more, moderate function between 10 and 40% and poor function less than 10%
- Antegrade pyelography, if there is doubt in the diagnosis of PUJ or in suspected cases of vesicoureteric junction obstruction





**Fig. 12.1A:** IVP of a child depicting right pelviureteric junction obstruction

- IVU or IVP is now replaced by ultrasound and renogram. IVU is indicated in presence of duplex system, horseshoe kidney or ectopic ureteric opening. It is the traditional investigation for precise anatomy and function (Fig. 12.1A). Crescent sign due to contrast medium in the stretched collecting ducts is diagnostic. IVU is a reliable indicator of recoverable renal function
- Micturating cystourethrogram (MCU) is indicated if the ureter is dilated, there is bilateral hydronephrosis or in presence of urinary tract infection (UTI)
- Pressure flow studies—Whitaker's test is done in equivocal cases. It is now rarely needed after the advent of nuclear imaging.

In all neonates with antenatally detected hydronephrosis, an ultrasound examination is performed first at birth within a week and then repeated at 4–6 weeks of age to confirm persistence of hydronephrosis. The renal scintigraphy is performed at 4–6 weeks when the renal maturity has better developed. Only 4–10% cases of hydronephrosis due to PUJ may have associated VUR, unilaterally or bilaterally, requiring evaluation for that. MCU is not recommended in all cases with PUJ. It is recommended in selected cases who present with the followings: (1) poor urinary stream, (2) history suggestive of UTI, (3) bilateral PUJ obstruction and (4) if the ultrasound had suggested dilated ureter and/or bladder and posterior urethral changes indicating obstruction distal to PUJ.

If the renal scan shows an enlarged renal pelvis, with significant delay in excretion and a persistent rising curve, with or without decrease in split renal function, the diagnosis of PUJ obstruction is essentially confirmed.

Over 50–70% cases with hydronephrosis detected before birth, may completely resolve with the passage of time, without any risk of loss of renal functions. Function may remain stable in 20–30% cases despite presence of hydronephrosis. However, in 10% cases, the function would deteriorate. Hence, a close follow-up is required in most of these especially during the first 2 years, to identify the subgroup of children who would demonstrate obstruction and require surgery.

Preoperative percutaneous nephrostomy (PCN) drainage is warranted in patients with infected hydronephrosis, a giant hydronephrosis, bilateral gross hydronephrosis and in a solitary functioning hydronephrotic kidney presenting with uremia. Preoperative drainage restores the deranged renal parameters, provided there is no inherent dysplasia. PCN drainage may be kept for 3–4 weeks in all children who present with poorly functioning kidneys due to hydronephrosis.

### Indications for Surgery

- All children presenting with symptoms—lump, pain and infection
- PUJ is associated with horseshoe, pelvic and crossed fused kidney
- If the split renal function is less than 40% in the affected side, supported by delayed excretion and an obstructive renogram curve
- Deterioration in split renal function from normal to less than 40% function
- A fall of more than 10% of the original value on the affected side at follow-up
- Postnatal anteroposterior diameter of the pelvis is more than 20 mm on USG.

Surgical procedures include:

- Excision of PUJ
- Formation of a funnel-shaped renal pelvis
- Dependent drainage
- Watertight and tension free anastomosis
- Excision of the redundant pelvis
- A straight pelviureteric anastomosis, without any redundancy around PUJ.

The surgical exposure to the kidney is a critical factor in achieving the above said goals. Appropriate access to the kidney may be achieved through lumbar, lumbotomy or the subcostal incisions. The classical Anderson-Hynes or a variation thereof is the most common procedure performed using the open technique (Fig. 12.1B). It is applicable to most variants of the anomalous anatomy and is particularly



**Fig. 12.1B:** Anderson-Hynes pyeloplasty procedure in process

useful in cases of high insertion of the ureter and presence of lower polar crossing vessels. The technique allows a complete excision of the abnormal segment of the upper ureter, excision of the redundant pelvis, a dependent drainage and a wide pelviureteric anastomosis.

### Choice of Drains

Following PUV repair, the need for postoperative urinary drainage and the choice of placing a nephrostomy tube, double “J” stent or a single transanastomotic stent (TAS) has always been controversial. Whereas the use of internal “J” stents or the nephrostomy drainage needs to be carefully individualised, the perirenal area is always drained with a corrugated drain or a closed suction drain. This prevents any collection around the anastomosis, sepsis and scarring. It is brought out either through the lateral part of the main wound or a separate stab skin incision.

### Complications

#### Bleeding

Bleeding is common after nephrostomy drainage. Bleeding can jeopardise the repair by formation of clots. Slight haematuria settles down gradually in next few days. A frank bleeding requires an immediate exploration. Irrigation of the nephrostomy tube should be avoided, as it introduces infection and can disrupt the suture line.

#### Urine Leak

Urine leak may occur within the first 24 hours. Drainage lasting over a week is of concern, because subsequent peripelvic and periureteral fibrosis harms the anastomosis

and can cause secondary obstruction. Prolonged leakage can be managed by placing a double “J” stent endoscopically across the anastomosis and also keeping the bladder empty with a Foley’s catheter. A PCN may be required if the infection has set in.

### Obstruction

If obstruction develops at the PUV, it can be managed by leaving the stent or the nephrostomy tube in place for long, until the infection clears and the PUV opens up on a nephrostogram. For obstruction which persists, attempt should be made to place a double “J” stent from below. If these measures fail, allow the area to heal for 10–12 weeks before contemplating a redo pyeloplasty. With the availability of endourologic intervention procedures, many cases of obstruction are now amenable to endoscopic retrograde stenting, balloon dilatations or percutaneous incisions of strictures at PUV.

### Redo Cases

For a case of redo pyeloplasty, emphasis is on gaining an adequate surgical access for a wide variety of surgical options. If the procedure is being done within first week or so of the initial pyeloplasty, same incision is reopened. A transperitoneal anterior approach may be preferred for all difficult redo cases and so also for the PUVs associated with giant hydronephrosis, horseshoe kidney, duplex hydronephrotic moiety, cross-fused renal ectopia and the pelvic kidney. It offers a direct and wide access to the complicated and an anatomically abnormal PUV. The possible redo procedures include repeat pyeloplasty, ureterocalicostomy, ureteric replacement by appendix or an ileum, autotransplantation or even nephrectomy.

### Ureterocalicostomy

Anastomosis of the proximal ureter directly to the lower pole calyceal system is best suited as a salvage procedure for cases with the difficult redo pyeloplasty. Also in the patients on prolonged nephrostomy drainage, the identification of the renal pelvis becomes very difficult due to shrinkage and scarring. In such situations, the choice is to anastomose the lower pole calyx with the available ureter after excising the overlying renal parenchyma. This procedure is, therefore, best suited for kidneys with a large, dilated lower pole calyx with overlying thinned out parenchyma. Sufficient cortex must be removed to protect the proximal ureter from entrapment. The calyx must also be partly mobilized to create a tension free anastomosis.

In cases of horseshoe kidney with hydronephrosis, although an extraperitoneal flank approach is enough for the

unilateral cases. For those requiring bilateral procedures, a transperitoneal approach is preferred. The vascular supply to the horseshoe kidney is quite variable, with the isthmus and lower pole frequently receiving blood from the common iliac. The gonadal vessels pass over these lower renal vessels. The ureters lie nearer the midline than normal. Division of the isthmus which was once thought to be the cause of obstruction must not be done.

### Endoscopic Procedures

The benefits of endourologic management of PUJ obstruction are less well established and in some cases offer no advantage over open pyeloplasty especially in younger children. It can be performed retrograde or antegrade. Several factors like the age of patient, the presence of primary or secondary PUJ, the degree of obstruction, the presence of crossing vessel and the overall differential function determine the success of the endoscopic procedure. However, the procedure is not suitable for the neonates and the infants with primary PUJ obstruction due to the technical. In the older children, the ureter caliber is more or less like that of adults, thus these patients may benefit from the endourologic procedures. Children with secondary PUJ obstruction respond better to the endourologic interventions. The success rate is less (77%) in case of massive hydronephrosis as compared to those with moderate disease (95%).

Laparoscopic pyeloplasty was developed in an attempt to duplicate the high success rates achieved with open pyeloplasty while offering advantages of minimally invasive techniques. Laparoscopic pyeloplasty can be performed in most patients with PUJ; however, an expertise in laparoscopy is required for an effective and purposeful procedure. The indications for laparoscopic pyeloplasty include a failed retrograde or antegrade percutaneous endopyelotomy, patients with anatomic abnormalities such as horseshoe or pelvic kidney, patients with crossing vessels crossing at PUJ and the extremely dilated pelvis. The contraindications of laparoscopic pyeloplasty are small intrarenal pelvis, kidneys with poor function following the prolonged obstruction and the failed open pyeloplasty.

### BIBLIOGRAPHY

1. Gupta DK, Chandrasekharam VV, Srinivas M, et al. Percutaneous nephrostomy in children with ureteropelvic junction obstruction and poor renal function. *Urology*. 2001;57:547-50.
2. Gupta DK, Sharma S. Postoperative outcome following pyeloplasty in children using miniflank incision and transanastomotic stent: a prospective observational study. *Pediatr Surg Int*. 2011;27:509-12.

## EXSTROPHY OF BLADDER

Bladder exstrophy is a congenital defect that is characterised by malformation of the bladder and urethra, in which the bladder is essentially inside out and exposed on the outside of the abdomen through the defect below the umbilicus. Because the bladder is exposed to the outside of the body, urine constantly dribbles out and the child develops local infection and ammoniacal dermatitis. Boys will have a short penis, which is bent towards the dorsal aspect of penis called chordee. In the female, the clitoris is bifid. The urethral opening is on the dorsal aspect (epispadias) and the anus and vagina are anteriorly displaced. Additionally, the pelvic pubic ramus is widely separated (pubic diastasis), outwardly rotated legs and feet, and there is displacement of the umbilicus upwards.

### Embryology

Many believe that it is caused abnormal persistence of the cloacal membrane. If this membrane does not disappear at proper time during foetal development, anterior aspect of the bladder and the soft tissue covering the lower abdomen are never formed correctly. As a result, neither the bladder nor the skin and the muscle of lower abdominal wall close leading to exstrophy of bladder.

### Incidence

This disorder occurs one in every 30,000 live births. It is two to three times more common in boys than girls. If a child has bladder exstrophy the chance of his sibling having bladder exstrophy is increased to about 1 in 100.

### Issues in Exstrophy of Bladder

#### *Epispadias*

The urethra is not formed completely and the urethral meatus is on the dorsal aspect of penis. In boys, the penis is flattened and is bent towards the abdomen called as dorsal chordee. In girls, the urethral opening is located between a divided clitoris and labia minora. After reconstruction of urethra it increases the resistance to urinary flow and helps in the bladder growth. Cantwell-Ransley's epispadias repair is the commonly done operation and carried out when the child around 2-3 years.

#### *Vesicoureteric Reflux*

Reflux is a condition where urine goes back up from the bladder into the kidneys. Reflux becomes serious when infected urine in the bladder travels to the kidneys, which can lead to scarring of kidney leading to loss of kidney

function. All patients after bladder closure are put on antibiotic prophylaxis to prevent UTI and scarring of kidney. Reimplantation of ureter is done during bladder neck repair or augmentation surgery.

### *Pubic Diastasis*

Separation of the pubic bones which does not allow the bladder to remain inside the body and can cause waddling gait.

### *Small Bladder Capacity*

All exstrophy of bladders are small at birth, some smaller than others. The extent to which the bladder will grow cannot be definitely determined. Successful bladder closure and epispadias repair increase urethral resistance and help the bladder to grow. If the bladder capacity does not improve and the intravesical pressure remains high the patient will need to increase the size of the bladder by augmentation surgery using a patch of colon, stomach or ileum. After augmentation few complications may be encountered. The spectrum of complication observed is electrolyte imbalance, acid-base imbalance, impaired sensorium, altered hepatic metabolism, abnormal drug metabolism, growth retardation, bone disorder and malignant changes.

### *Incontinence of Urine*

The bladder neck and sphincter complex are not well formed in these patients and hence they have incontinence of urine. After bladder closure and epispadias repair the continence slowly improves with time. If it does not improve, then bladder neck repair surgery has to be done around 3–5 years. Some children may require clean intermittent catheterisation to adequately empty their bladders. Use of agents like collagen, silicone and other substances, which can now be injected at the neck of the bladder may help to increase resistance and to improve the continence.

### *Bladder Stones*

The incidence of stone formation varies incidence range from 10 to 25% and up to 52% after augmentation cystoplasty. The predisposing factors are chronic bacteriuria, urinary stasis, immobility and mucus production, and metabolic abnormality, foreign body like sutures, catheters and staples.

### *Urinary Tract Infections*

They are prone for urinary infection due to VUR, repeated catheterisation or mucus production after augmentation with bowel.

### *Inguinal Hernias and Undescended Testes*

There can be bilateral inguinal hernia and undescended testes due to abnormal muscle development of anterior abdominal wall. These need correction later. Undescended testis (UDT) is thought to be due to unclosed bladder creating reduced abdominal muscle.

### *Genital and Reproduction Problem*

The fertility in males is questionable although they are not impotent and is due to retrograde ejaculation or scarred or damaged vas deferens. Almost all females are able to have children but will need caesarean section for delivery due to adherent uterus abnormal uterovaginal angle.

### **Investigations**

- X-ray of the pelvis—to know the degree of pubic diastasis
- Ultrasonogram—it diagnoses renal anomaly, hydro-ureteronephrosis and renal damage due to reflux, bladder capacity and post-void residue after the bladder closure
- Renal isotope scan—nuclear imaging include DTPA for drainage pattern and differential renal function, DMSA for renal scars due to reflux and GFR for global renal function
- Micturating cystourethrogram—done after the bladder closure to know the bladder contour, capacity, VUR, urethral profile and post-void residue
- Urodynamic study—to know the bladder capacity, bladder pressure, compliance, detrusor sphincter coordination, uroflometry, post-void residue, etc.

### **Treatment**

The treatment is only surgical. The primary goals of reconstruction are:

- Closure of the bladder and urethra
- Closure of the abdominal wall
- Preservation of kidney
- Good urinary continence
- Sexual function
- Improved appearance of genitalia.

### *Staged Repair*

There are usually three stages of reconstruction. The goal of this staged reconstruction is to have patients with a normal urinary tract, satisfactory external genitalia and adequate dry intervals.

1. *1st stage*: Closure of bladder and abdomen (24–48 hours of life)
2. *2nd stage*: Epispadias repair (2–3 years)
3. *3rd stage*: Achieve urinary continence by bladder neck repair and augmentation (4–5 years).

The 1st stage involves internalisation of the bladder and closing the abdomen and should be performed, ideally, within the first 48 hours of life, if at all possible. Within this time frame, the bones are pliable, the changes in the bladder lining have not occurred yet and the bladder and abdominal wall can usually be closed without disrupting the bony pelvis (iliac osteotomies).

The 2nd stage consists of reconstruction of external genitalia in male child epispadias repair with reconstruction of phallus and in females clitoral repair is done at 2–3 years of age.

Later, in 3rd stage, if bladder is too small to cope with urinary volume and it will lead to incontinence of urine, high pressure within the bladder leading to kidney damage due to poor drainage and VUR. In this case, a bladder enlargement (augmentation) by using stomach, ileum or colon can be done which will increase the bladder size, reduce the bladder pressure and improve the continence. This is usually done at 4–5 years of age, and often coincides with a reconstruction of the bladder neck. If the patient does not improve with regards to urinary continence closure of bladder neck and creation of continent catheterisable channel from the bladder onto the abdominal wall namely the Mitrofanoff operation can be carried out.

### *Single Stage Total Reconstruction of Exstrophy Bladder*

Due to improvement in surgical technique, good postoperative care and safe anaesthesia, total reconstruction of the exstrophy can be undertaken in single stage. The outcome following single stage reconstruction is found to be better than staged repair.

## BIBLIOGRAPHY

1. Gillenwater JY, Grayhack JT. Adult and Pediatric Urology, 3rd edn. CV Mosby Co; 1991.
2. Ashcraft KW. Pediatric Surgery, 3rd edn. WB Saunders Company; 2000.

## UNDESCENDED TESTIS OR CRYPTORCHIDISM

An undescended testis is one, which cannot be made to reach the bottom of the scrotum and remains high along its line of descent (Fig. 12.2). The incidence of UDT is 2.7–3% at birth in the full-term infants. The incidence decreases to around 1% after 1 year of age and thereafter remains the same. It is much more common in premature infants approaching 100% at gestational age of 32 weeks or less.

An ectopic testis is one that has strayed from the inguinal canal, usually to the thigh, perineum, base of penis, femoral or even to the other side of the scrotum. The superficial



**Fig. 12.2:** Bilateral undescended testes with underdeveloped scrotum

inguinal pouch is the most common site for the ectopic testis. Ascending testis is one that has descended once and was there in the scrotum at birth, but as the spermatic cord fails to elongate at the same rate as the body growth, the testis ascends up progressively, and becomes high in inguinal canal by the childhood. An impalpable testis is quite uncommon (less than 10%) and agenesis is rare (2% of all cases of UDT and about 20% of all impalpable testis). A fully descended but grossly hypoplastic testis may be impalpable and identified only on exploration.

The retractile testis is a testicle having completed the descent process but is not in its normal scrotal position secondary to a hyperactive cremasteric reflex. Strong contraction of the cremaster muscle may pull the testis from the scrotum into the superficial inguinal pouch. Abnormally highly located gubernacular attachment may cause the testis to migrate high during a cremasteric reflex. The cremasteric reflex becomes most active at ages 5–9 years. Ascent of the testis at this time may prevent the prepubertal testis from growing normally, as commonly seen with gliding and severe retractile testis. The testis and scrotum are usually well developed. It is possible to bring the testis into the scrotum by dragging the testis and it remains there for some time. The Chair test (Orr) may be helpful to bring down the retractile testis in difficult cases. The child is asked to sit on a chair keeping both feet on the seat with extreme flexion of the knees towards the chest. Testicular function and fertility are normal. It is now believed that there is no role of hormonal therapy.

### Embryology

During the 5th–6th week of gestation, the gubernaculum forms from a band of mesenchyme and extends from the

genital ridges through a gap in the abdominal wall musculature to the genital swellings which will develop into the scrotum. Primordial germ cells from yolk sac migrate along the dorsal mesentery of the hind gut to reach the genital ridges.

During the 7th week, under the influence of H-Y antigen, the indifferent gonads differentiate into foetal testes.

Foetal testis becomes normally active by the 8th week, secreting testosterone and Müllerian-inhibiting substance (MIS). MIS is secreted by foetal Sertoli cells stimulated by FSH from pituitary and causes regression of the Müllerian ducts.

During the 10th–15th week, testosterone produced by Leydig cells stimulate differentiation of wolffian duct to form the epididymis, vas deferens and seminal vesicle. Leydig cells are stimulated by placental chorionic gonadotropin and pituitary LH. Differentiation of external genitalia depends on the presence of 5-alpha-reductase, which converts testosterone to dihydrotestosterone (DHT). The processus vaginalis forms as a hernial sac through the weakness in the abdominal wall adjacent to the gubernaculum and gradually extends into the scrotum. The process of testicular descent remains dormant until the 7th month of gestation.

At the 7th month, the gubernaculum increases in size, distending the inguinal canal and scrotum. The testis then descends through the inguinal canal into the scrotum. Epididymis, attached to gubernaculum, precedes the testis in its descent into the scrotum.

Thus, the normal descent of testes occurs at about the 7th month of foetal life when the gubernaculum swells and shortens, drawing the testis through the inguinal canal into the scrotum.

After the descent, gubernaculum persists as fibrous band, the gubernacular ligament. Processus vaginalis is completely obliterated prior to birth.

### Factors Responsible for Testicular Descent

- Traction of the testis by the gubernaculum or cremaster muscle or both
- Differential body growth
- Increase in intra-abdominal pressure
- Development and maturation of the epididymis
- Changes resulting from androgen environment—milieu, directly or indirectly mediated through the spinal nucleus of genitofemoral nerve innervating the gubernaculum which stimulates the release of calcitonin gene-related peptide (CGRP)
- Role of oestrogen and MIS.

Failure of the descent may occur due to the hormonal failure (inadequate gonadotropins and testosterone), dysgenetic testis or an anatomic abnormality such as abnormal

or malplaced gubernaculum, obstruction of inguinal canal or scrotum or the shortened vas and/or vessels.

### Sequelae of Nondescent

- *Infertility*: The higher temperature of the extrascrotal testis causes testicular dysplasia with interstitial fibrosis and poor development of seminiferous tubules thus hampering the spermatogenesis. Testosterone production is unaffected by the testicular position, thus a male with bilateral undescended testes will develop secondary sexual characters yet may be sterile.
- *Trauma*: The testis in inguinal region is also more prone to direct trauma.
- *Torsion*: The chances are greatest in the postpubertal period when testis usually increases in size.
- *Neoplasia*: The most serious complication due to the associated dysplasia existing in the testis is a higher chance of malignancy if left untreated (10–20 times on the affected side and about 7 times on the contralateral side). The risk of malignant degeneration is although not altered by doing an orchiopexy, yet few workers now have indicated that an early orchiopexy before 1 year of age or so may actually decrease the incidence of malignancy. Malignancy, usually a seminoma, develops only in the second or third decade of life.
- Hernia due to patent processus vaginalis.
- Atrophy results in untreated cases.
- Feeling of incompleteness psychologically.

On examination, always look for a hernia. The position and the size of the testis should be noted, if impalpable, ectopic locations of the testis should be examined. There are many associated anomalies that are quite common with UDT: intersex disorders, prune belly syndromes, exstrophy bladder, spina bifida posterior urethral valves and prune belly syndrome (Fig. 12.3). Any child with unilateral or bilateral UDT associated with hypospadias, needs to be investigated for intersexuality by performing chromosomal analysis, hormones assessment, genitogram and the tests to confirm the presence or the absence of the Müllerian structures.

### Histological Changes

Pathological changes may occur as early as 6 months. Impaired Leydig cell development has been shown as early as 2–6 months, whereas sertoli and germ cells appeared normal. There could be delayed germ cell maturation, reduced germ cell number and hyalinisation of seminiferous tubules. These changes are reversible up to 2 years of age. Histologic changes in cryptorchid testis include degeneration of mitochondria, loss of ribosomes, increase in the collagen fibres in the spermatogonia and Sertoli cells.



Fig. 12.3: Prune belly syndrome

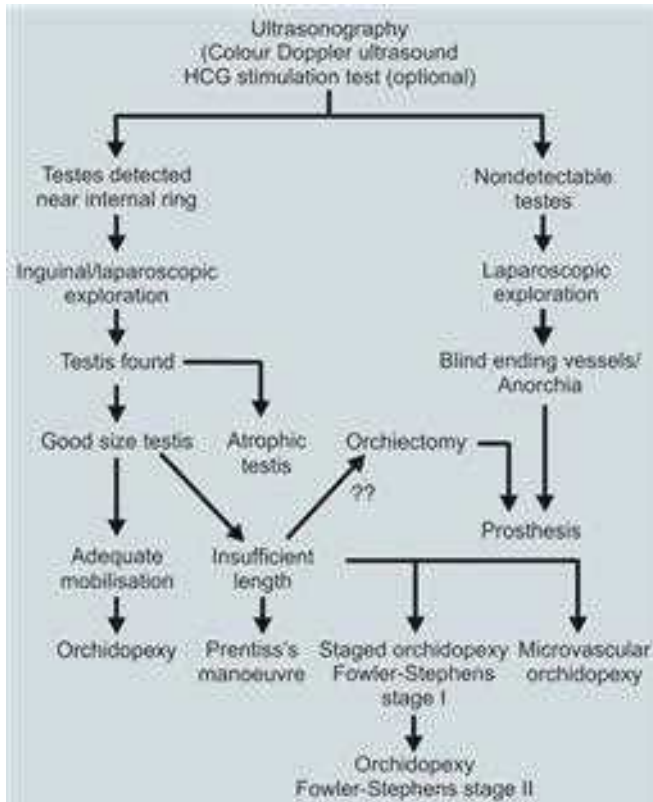


Fig. 12.4: Algorithm for management of impalpable undescended testes

## Treatment

The histological changes in the testes occur as early as 6 months of postnatal life and therefore, a child who has an UDT should be operated at the earliest to prevent them. The best time for orchidopexy is about 1 year of age, but where facilities of surgical expertise and paediatric anaesthesia are available, it may be considered even before 9 months of age. A still early surgical procedure is usually associated with higher complication rate with injury to the vessels and the vas (2–3%). Figure 12.4 outlines the algorithm for management of impalpable undescended testes.

## Methods of Orchidopexy

### Extra-Dartos Pouch-Conventional Orchidopexy

An inguinal incision is made, the hernial sac is dissected from the cord structures and a high ligation of the sac is done. The testis is placed in an extra-dartos pouch in the scrotum; an adequate dissection should be done to avoid tension on the pedicle while placing the testis in scrotum. Any torsion of the pedicle should be avoided. Retroperitoneal dissection and careful snipping off of lateral peritoneal bands will give an adequate length to the cord.

If the testis does not reach the scrotum easily then the inferior epigastric artery and vein can be ligated and the testis brought directly through the transversalis fascial floor (Prentiss manoeuvre).

### Transcrotal Orchidopexy

It is performed through a skin crease incision in the neck of the scrotum. High ligation of processus vaginalis, dissection of the spermatic cord and placement of the testis in an ipsilateral subdartos pouch constructed through the same incision is done. Advantage includes minimal dissection through a single incision and avoidance of disruption of the inguinal canal.

### Fowler-Stephens Technique

It comprises of division of the main testicular vessels and relies on delicate vasal and cremasteric collaterals for testicular survival and growth. It is associated with 50–100% atrophy rate.

### Staged Fowler-Stephens Technique

It is a two-stage procedure. Ligation of the spermatic vessels to gain length is done as stage I operation by open or laparoscopic method to allow the collateral blood supply to develop without mobilising the testes. After about 6 months

waiting, at 2nd stage, the testis can be brought into scrotum by inguinal exploration. The testicular blood supply is supported by the artery to the vas.

### *Multistage Orchiopexy*

The testis is mobilised and brought into the inguinal canal as far as possible. The testis and spermatic cord are wrapped with a silicone sheath to prevent adhesions. After 1 year waiting, at 2nd stage, the testis is brought down to the scrotum.

### *Microvascular Orchiopexy (Testicular Autotransplantation)*

Microvascular transfer of testes is the best procedure to avoid atrophy of the testis but it needs great surgical expertise and the equipment. This procedure involves high mobilisation of the testicular vascular pedicle and also carefully safeguards the vas and vasal collaterals. Following division of the blood supply, the testis is transferred to the scrotum and immediately revascularised by one arterial and one or two venous anastomosis to the inferior epigastric vessels. In expert hands, a success rate of over 80–90% is now possible.

### *Refluo Technique*

It consists of full venous drainage by microvascular anastomosis of the testicular vein to the inferior epigastric vein, but relies on the arterial input from the vasal collaterals.

### *Ombredanne Procedure*

The testis is put into the contralateral scrotal sac through the scrotal septum.

In cases of impalpable testis, in about 50% a useful testis can be brought down and in the other 50% there is either possibly a testicular agenesis or atrophy due to the intrauterine torsion resulting in the vanishing testis. A useless and potentially neoplastic testis must be removed. If the testis is difficult to be brought to the root of the scrotum, it should be brought down as much as possible but without any tension and fixed, possibly to the pubic tubercle to make it easily palpable for detection of enlargement, if any.

### **Role of Hormones**

Hormones, human chorionic gonadotrophin (HCG) and gonadotrophin-releasing hormone (GnRH) therapy play multiple roles. Hormones, mainly the HCG, have been used for the detection of anorchia in cases of impalpable testis. In cases of bilateral UDT, an HCG test (1,000 IU on alternate days for 3 injections) is performed to see change

in level of testosterone. A less than 20-fold rise is indicative of anorchism and surgery is not indicated in these patients. These days, laparoscopy is a much better modality for this purpose.

HCG is also used to achieve partial or complete descent of UDT and the secondary benefits for redo cases, i.e. for the enlargement of the testicular volume, the vessels and the scrotum. Under the HCG effect, the spermatic vessels become more pliable and the length of the cord is also increased. The scrotum becomes more capacious. The results following the hormonal therapy are known to be better if the testis is low-lying (inguinal or high scrotal), retractile, unilateral, good in volume and in boys above 8 years of age. Since, the therapy is effective in only 20–30% cases, it is not widely used.

### **Laparoscopy**

Paediatric laparoscopy has evolved as an important tool in the search for the impalpable testis. Laparoscopy has 95% sensitivity for locating a testis or proving it absent. It seems to offer a safe and reliable diagnostic and therapeutic option to patients with impalpable testis.

Intra-abdominal detection allows more testes to be brought down to the scrotum. Laparoscopy obviates the need for groin exploration in many cases.

Technically a 1st stage Fowler-Stephens procedure can be performed easily and effectively with the help of a laparoscope.

If the testicular vessels are seen to end blindly this signifies that the testis is absent on that side and that no surgical exploration is necessary. If the vessels are seen to enter the internal inguinal ring, an inguinal exploration or laparoscopic assisted orchiectomy or orchiopexy is required.

If the testis is seen in the abdomen a decision may be made either to perform an extra-abdominal exploration and attempt to place the testis in scrotum or to clip the testicular vessels and perform an orchiopexy at a later date.

### **Complications of Orchiopexy**

- Failed orchiopexy
- Recurrence of undescended due to inappropriate choice of surgical technique
- Testicular re-ascent: Testis becomes tethered to the operative scar and retracts out of the scrotum over time with increasing body growth
- Testicular atrophy
- Vas and vessel injury.

### **Indications for Orchiectomy**

- Malignancy
- Testicular atrophy
- High intra-abdominal testis that cannot be brought down.



## Prosthesis

If orchiectomy has been done, for psychological reasons—a prosthetic placement should be performed, firstly in the childhood as it allows the growth of the scrotum. Later on around puberty, the prosthesis can be replaced by an appropriate sized one if the need be. This is only for psychological satisfaction.

## Prognosis

There is 2% recurrence, 2–5% incidence of atrophy, 70–80% fertility after unilateral orchiopexy and 40% fertility after bilateral orchiopexy. Higher the location of the gonad, higher are the chances of malignancy and poorer the outcome for fertility. If the orchiopexy is delayed beyond age of puberty in the bilateral cases, there are no chances of fertility.

## BIBLIOGRAPHY

1. Gupta DK. Indigenized Teflon Testicular Prosthesis in Children—an AIIMS Experience. In: Ambiguous Genitalia and Hypospadias In: Gupta DK (Ed). New Delhi: Printext Publishers; 1999. pp. 113-4.
2. Gupta DK, Menon PS. Ambiguous genitalia in children: an Indian perspective. *Indian J Pediatr.* 1997;64:189-94.
3. Gupta DK. Paediatric intersex disorders. In: DK Gupta (Ed). *Ambiguous Genitalia and Hypospadias*, Delhi: Printext Publishers; 1999. pp. 57-62.
4. Gupta DK, Sharma S. Common Inguinoscrotal Problems in Children, in *Recent Advances in Surgery*. In: Roshal Lal Gupta (Ed). 2006. pp. 147-61.
5. Gupta DK. Use of hormones for testicular descent in *Recent Advances in Paediatrics*. Gupta Suraj (Ed). New Delhi: Jaypee Brothers Medical Publishers; 1991. pp. 113-5.
6. Rohatgi M, Gupta DK, Menon PS, et al. Hormonal therapy in undescended testes. *Indian J Pediatr.* 1991;58:79-83.

## PHIMOSIS

Phimosis is defined as the excessive tightness of the foreskin, preventing retraction behind the glans. At birth, if the meatus is visible at the glans (even without any preputial retraction), there is no phimosis. The separation of prepuce from the glans surface continues and is completed by the age of about 2 years. At this age, if the prepuce cannot be retracted fully or balloons out on micturition, there is phimosis. It occurs in only 1–2% males. Usually, it is mild and a simple separation and retraction is all that is required in most cases. An epithelial debris is usually present at the coronal sulcus and forms the source of constant irritation and infection. A forced retraction may worsen the phimosis by producing tears in the foreskin, which heals with scarring and contraction. If there is pooling of urine and repeated attacks of balanoposthitis, then simple dilatation of the foreskin can be done with due care regarding the local hygiene.

After the age of 2 years, adhesiolysis can be done as an outpatient procedure (stretching and forcibly separating the glans from the inner layer of prepuce). Daily retraction and cleansing of the glans is very important and must be continued for at least for 10–15 days. This will prevent recurrence of the phimosis. An antibiotic cream may be used as a lubricant to prevent re-adhesion formation. Few centres promote the use of steroid creams for this purpose. It is not our practice to use any steroids for this. It must be emphasised that after retraction of the prepuce, the same must be repositioned back on to the glans, to avoid any risk of paraphimosis. A dorsal slit in the prepuce may be needed if the prepuce is too tight. Circumcision is the last resort and indicated only if the preputial skin is scarred and fibrotic and dilatation and adhesiolysis have not been successful.

Circumcision is a tradition in some religions and performed as a routine in all male babies even without phimosis. It is interesting to know that female circumcision is also practised in some areas of Saudi Arabia on religious grounds.

## PAEDIATRIC INTERSEX DISORDERS

The problem of a child with hypospadias and undetermined sex is although not uncommon, yet quite poorly understood subject. Due to the availability of limited expertise in this field, most of the children are either never diagnosed or mismanaged.

### Definition

An intersex disorder may result from an abnormal genetic sex, an abnormal gonadal differentiation and an abnormal phenotype sex. A child with hypospadias with unilateral or bilateral undescended gonad qualifies to be investigated for ambiguity (Fig. 12.5). All patients with the scrotal and perineal hypospadias should also be investigated with



**Fig. 12.5:** A child with hypospadias with unilateral or bilateral undescended gonad needs to be investigated for ambiguity

retrograde genitourethrogram (RGU) to evaluate them for any evidence of presence of the Müllerian structures.

The development of the embryo is quite complex and takes place under the influence of sex chromosomes and hormones into a male or a female foetus with normal internal and external genitalia. It is the presence of Y chromosome that induces masculinisation on the female foetus, possibly under the influence of H-Y antigen, testis determining factor (TDF), anti-Müllerian hormone (AMH) and SRY gene. Any chromosomal abnormalities, failure of migration of the primitive germ cells from the yolk sac to the urogenital ridge, absence of the production of anti-Müllerian substance (from the sertoli cells) and testosterone (produced by Leydig cells), overproduction of androgens in the females and finally the lack of the androgen receptors, especially in the genital tissues, may affect the chain of sequence of development and lead to an abnormal development of genitalia in the newborn.

### Classification

Recently, the Lawson Wilkins Paediatric Endocrine Society (LWPES) and the European Society for Paediatric Endocrinology (ESPE) have proposed changes to the nomenclature and definitions of disorders in which the development of chromosomal, gonadal or phenotypic sex is atypical (Table 12.1). This terminology mainly reflects the chromosomal sex or the gonadal tissue associated with the disorder.

### Clinical Evaluation

The clinical evaluation is based on the knowledge of the five main types of intersex disorders:

1. *Male pseudohermaphroditism (MPH)*: This is the most common disorder and accounts for more than 50% cases of intersex disorders. The gonads are testis. These are symmetrical, although may be undescended unilaterally or bilaterally. There is always a vaginal pouch but never a uterus. Phallus may be small or normal in size. There is scrotal or perineoscrotal hypospadias with a large

single urogenital sinus. Vaginal orifice is not visible in the perineum. Chromosomal pattern is 46,XY with no mosaicism.

There are two important subtypes of this disorder:

- a. Testicular feminisation syndrome (TFS) (complete or incomplete)
- b. 5-alpha-reductase deficiency—in these, the baby is phenotypically a female with both the gonads in the labial folds.

The vaginal orifice may be visible in the vestibule. The other sib may also be affected. There is either the androgen receptor failure or due to the enzymatic deficiency, testosterone is not converted into DHT. The serum testosterone levels remain normal although part of it is converted to oestradiol resulting in breast development at puberty. The serum DHT level, if measured, would be found low. So far it is not possible to differentiate these two subtypes in our setup as the facilities to estimate testosterone/dihydrotestosterone (T/DHT) ratio are not there.

2. *Congenital adrenal hyperplasia (CAH)*: Mostly it is due to the deficiency of 21-hydroxylase in over 90% cases resulting in excess of 17-hydroxyprogesterone (17-OHP) in a female baby with 46,XX. There is varying degree of clitoral enlargement and a large urogenital sinus. The vaginal orifice may be completely hidden under the skin fold. The next common deficiency of 11-beta-desmolase enzyme results in excessive vomiting and a serious salt loss and even deaths may occur within few days after birth.
3. *True hermaphroditism (TH)*: Apart from the ambiguous genitalia, there has to be an ovarian as well as a testicular tissue in the same child. There is a single urogenital sinus. Vaginal orifice is mostly covered with the skin flap. The scrotum develops only if the gonad has reached it. Phallus is usually well developed but could be tiny. The phallus is usually triangular in shape. The single meatus is wide. The presence of a dumb-bell shape of a gonad with double consistency (if palpably descended), unilateral or bilateral is diagnostic of TH. The ovarian component is firmer and the testis is softer. Most of TH cases are 46,XX while only 10–15% cases are 46,XY and only a few have mosaicism.

In TH, there could be various forms of combinations of the internal gonads resulting in a pair of ovary and testis, testis/ovotestis, ovary/ovotestis and bilateral ovotestis. Usually the ovarian gonads are abdominal in location and is accompanied by a fallopian tube while the testis descends into the scrotum depending on the testicular volume and maturity and has vas as the draining duct. Regarding ovotestis, the descent and the draining duct will depend again on the amount of testicular

**Table 12.1:** Old and revised nomenclature of disorders of sexual development

Old nomenclature	Revised nomenclature
Female pseudohermaphrodite	46,XX DSD
Male pseudohermaphrodite	46,XY DSD
True hermaphrodite	Ovotesticular DSD
Mixed gonadal dysgenesis/XX male	46,XX testicular DSD, 46,XY DSD or sex chromosome DSD if there is mosaicism (45,X/46,XY)
Pure gonadal dysgenesis/XY sex reversal	46,XY complete gonadal dysgenesis

component in it; if testis is the major component, the ovotestis may fully descend in the scrotum or become palpable anywhere along the course of the descent of the testis, with the vas as the draining duct. However, there would never be both the vas as well as the fallopian tube on the same side of ovotestis.

In TH, uterus is present in about 90% cases but mostly it is hypoplastic and cord like. Uterus may be bulky only in 10–15% cases. In such children, at puberty, there may be cyclic haematuria and bilateral breast development, due to the oestrogen effect from the ovary. Detection of high values of oestradiol (due to the presence of ovarian gonad) on hormonal evaluation in a male child would strongly favour the diagnosis of TH. Testosterone values may be normal or low depending on the amount of normally functioning testicular tissue.

4. *Mixed gonadal dysgenesis (MGD)*: There is ambiguity of external genitalia with usually a tiny phallus. The vaginal and the urethral openings are usually been separately in the vestibule. The scrotum is very poorly developed. The internal gonads include a testis on one side and a small, flat, shiny streak gonad on the other side (usually on left side but may be on right side in 20% cases). The testis is dysgenetic and usually abdominal in location and usually does not descend unless better developed. The uterus is always present, and is usually hypoplastic. The chromosomal pattern may be 46,XY/XO/XXO and the mosaicism is the most common finding.
5. *Dysgenetic male pseudohermaphrodite (DMP)*: The clinical picture resembles that of MGD. However, in DMP, as both the gonads are always dysgenetic, fail to descend and remain abdominal in location. The scrotum is always hypoplastic. The uterus is also present. Phallic size is also variable. The abdominal gonads are rounded, yellowish and soft. The draining ducts resemble either the fallopian tubes or look like epididymis.

Based on the background knowledge of individual type of intersex disorder, the clinical evaluation includes:

- Size of the phallus
- Meatal location, urogenital sinus if any
- Bifid or hemiscrotum with or without rugosities
- Palpable unilateral or bilateral gonads
- Presence or absence of uterus on per rectal (PR) examination, ultrasound, CT, MRI or surgery
- Dumb-bell shape of the gonad with dual consistency
- Pubic hair, breast enlargement, abdominal mass.

The main investigations include:

- Chromosomal analysis
- RGU, USG and bone age

- Hormonal assessment (17-OHP, 24-hour urinary ketosteroids testosterone, LH and FSH, oestradiol)
- Laparotomy or laparoscopy, if possible
- USG for kidneys, adrenals, uterus and gonads
- MRI scanning is useful to delineate details of various pelvis structures and also to differentiate the ovary from the testis.

In general, a 46,XY is the most common pattern of chromosome found. It suggests that the intersex disorders could be an MPH (all types), TH (10–15% cases), MGD and DMP. The cases with the 46,XX pattern are either CAH (all) or TH (80%). Presence of Y line with a mosaicism suggests an MGD or DMP in most of cases.

An RGU establishes not only a vaginal pouch but may also reveal a cervical indentation, suggestive of presence of uterus. Rarely, the dye outlines the uterine cavity, fallopian tube(s) and may even spill into the peritoneal cavity suggestive of existence of Müllerian structures. The presence of uterus can also be made on PR examination and on USG. An advanced bone age is suggestive of CAH. USG is routinely performed for the evaluation of the renal tract, internal gonads, uterus and adrenal glands.

Hormonal evaluation is of particular importance in CAH, TFS and TH. A 4–5 time or more rises in levels of 17-OHP is very suggestive of CAH. A normal value of oestradiol in the presence of normal testosterone levels, is suggestive of presence of an ovarian source as in TH. Similarly, T/DHT ratio is changed in MPH group of patients with 5-alpha-reductase deficiency, resulting in low levels of DHT, although testosterone levels remain normal. In TFS, part of testosterone may be converted into oestrogens and result in breast development.

### Factors for Sex Assignment

It is the most crucial decision in an intersex child and is based on the information available on clinical evaluation (specially the phallic size and gonadal pattern) and the investigations. The genetic sex does not matter and plays no role in sex assignment of a child.

In the Indian society, the subject should be discussed in confidence with the parents and grandparents and the merits and demerits of each type of sex assignment should be explained in detail, in terms of surgical options, fertility, phallic reconstruction and vaginoplasty, need for hormonal supplementation insertion of testicular prosthesis and development of malignancy.

The surgical options—the points of considerations include:

- It is easier to convert an intersex child into a female rather than into a male.

- Fertility has not been reported in a male with any type of intersex problem, although few females have produced children.
- Presence of a Y line (on chromosomal analysis) is associated with a high degree of malignancy (75% after 26 years of follow-up). Hence, any abdominal (dysgenetic) testis with XY line must be removed latest by 12 years of age.
- It is easier to convince the parents and change the sex of rearing if the patient is under 1 year of age
- The Indian parents prefer to have an inadequate male rather than an inadequate female to sustain the various types of pressures of the society (marriage, livelihood, support).
- In older children, the assignment of sex is dictated by the size of phallus and the type of internal genitalia.
- If the phallus is adequate, a male sex is assigned and the "male genitoplasty" is undertaken in stages. It includes:
  - Chordee correction and urethroplasty
  - Removal of an unwanted intra-abdominal gonad
  - Biopsy of an inguinal or a scrotal testis
  - Insertion of testicular prosthesis (unilateral and bilateral)
  - Removal of uterus and/or ovary (as in TH)
  - Bilateral mastectomy
  - Testosterone supplementation near puberty to allow secondary sexual characters to develop.
- If there is a complete set of ovary, fallopian tube and uterus with or without adequate phallus, it is "desirable" to assign female sex and the "female genitoplasty" is done as follows:
  - Clitoroplasty or clitoral recession
  - Exteriorisation of vaginal orifice
  - Removal of unwanted gonad (as testis in TH)
  - Hormonal supplementation (progesterone and oestrogens)
  - Near puberty to allow the secondary sexual characters to develop.
- In the presence of unilateral or bilateral dysgenetic testis (abdominal location) and a tiny phallus, it is preferable to assign female sex and undertake the followings:
  - Removal of internal dysgenetic testis (as in MGD and DMP)
  - Clitoroplasty and vaginoplasty
  - Cyclic hormonal therapy with progesterone and oestrogens at puberty to prime the uterus for cyclic bleeding.

However, if the phallus is adequate, a male sex can still be assigned and the dysgenetic gonads be removed. The child would need testicular prosthesis for psychological reasons and the testosterone supplements at puberty for the development

and maintenance of secondary sexual characters. All TFS cases should be reared as female as the phallus is always very tiny. The gonads are usually well developed and the labial folds are quite prominent. The female sex assignment sexual characters to develop in patients with TFS require:

- Removal of both the gonads, so that the labia shrink in size
- Clitoroplasty with exteriorisation of vagina
- Oestrogen supplementation at puberty to have development of secondary sexual characters.

As there is no uterus in TFS patient, neither they can have cyclic bleeding nor can they be fertile. There are also differences of opinion regarding the timing of removal of the gonads. Surgeons in USA and France prefer to remove both the gonads in infancy and prime the child with oestrogens at puberty. We have been following a policy of removing one gonad (from better developed hemiscrotum) completely in infancy and fixing the other gonad into the anterior abdominal wall with the presumption that an endogenous oestradiol would continue priming the baby till puberty for a near normal type of development of psychological behaviour and secondary sexual characters. Also the re-fixing of the gonad allows the labial fold to shrink in size. As there is an 8% risk of malignancy in the testis, it is removed near puberty and the patient is put on oral oestrogens.

There have been instances when parents insist that despite a phenotypically female child, a TFS patient should be assigned a male sex at all costs. Although a TFS patient has 46,XY pattern, well developed and symmetrical gonads in the scrotum, yet the phallus is tiny and remains a major problem for reconstruction. There is also an 8% risk of developing malignancy of the gonads. Under the influence of oestradiol, bilateral breast development occurs at puberty and there is no response to testosterone injections. Hence, male sex should not be assigned in TFS patients. However, the MPH patients have a chance of phallic enlargement near puberty under the testosterone therapy.

All CAH patients should be reared as female. They need first the suppression of adrenals with the steroids and when the 17-OHP is within the normal range, they need the followings:

- Clitoroplasty or clitoral recession
- Exteriorisation of the vaginal orifice
- Vaginal replacement—if required to be done at puberty
- Flourocortisone—florinef (for salt loosing type of CAH only).

Clitoroplasty should not be performed in an uncontrolled CAH. Also if the compliance to steroid intake is poor, there is a significant risk for the clitoral re-enlargement even after the clitoroplasty has been done. An annual follow-up for assessment of 17-OHP, bone age, height and weight

is mandatory to regulate the steroid doses and prevent its toxicity. Fertility has been reported in about 50% of the controlled CAH cases.

During the past 30 years, at the paediatric intersex clinic at AIIMS, 532 patients with various types of intersex disorders (MPH-219, CAH-107, TH-35, MGD and DMP-43, PMDS-5 and others 132) were managed. Their ages presented from newborn to adults. After preliminary investigations, proper sex was assigned taking into considerations the development of the external and internal genitalia, sex of rearing already assigned, the will of the patient (if possible) and the parents or the grandparents. Decision to assign a particular sex was never imposed on the parents or the patient. Appropriate surgical procedures were conducted in stages if so required. Parents and the patients were duly counselled for possibility of marriage and fertility. Regular follow-up was maintained for assessing the cosmetic results, psychosocial behaviour and hormonal management.

### Mental Health Concerns in Children Followed up with Intersexuality

The child with hypospadias and undetermined sex is uncommon and quite poorly understood. It is estimated that due to the limited facilities available, mostly in the metro cities, most of the children with intersex disorders are either never diagnosed or mismanaged. The purpose of this abstract to include the experience from the paediatric intersex clinic at AIIMS since 1980 on the mental health concerns in children under treatment for various types of intersex disorders.

Intersex children need to be diagnosed with a team approach. A detailed clinical assessment aided karyotyping, RGU, USG, laparoscopy and hormonal measurements, helps in arriving at a working diagnosis in almost 90% cases of intersex disorders. The role of laparoscopy and the laparotomy

**Table 12.2:** Revised nomenclature of disorders of sexual development and chromosomal pattern

<i>Revised nomenclature</i>	<i>Chromosomal pattern</i>
46,XX DSD	46,XX
46,XY DSD	46,XY
Ovotesticular DSD	46,XX—80%, 46,XY or mosaicism (45,X/46,XY)—10–20%
46,XX testicular DSD, 46,XY DSD or sex chromosome DSD if there is mosaicism (45,X/46,XY)	Mosaicism (45, XO/46, XY)— mostly, 46, XX, 46, XY
46,XY complete gonadal dysgenesis	46, XX, 46, XY, 46, XO

is both the diagnostic as well as the therapeutic and cannot be underestimated if there is doubt about the diagnosis.

In summary, the management of intersex cases is aimed at:

- Assigning a sex of rearing as early as possible
- Cosmetic reconstruction of genitalia (male or female)
- Making them capable of sexual performance (a phallic reconstruction or a vaginoplasty)
- Development of secondary sexual characters, appropriate for the sex assigned
- Hormonal manipulations, as and when needed
- Psychosocial adjustment and rehabilitation in the society
- Fertility, although possible, has been reported only in a few females in CAH and rarely in true hermaphrodites. No intersex male patient with Y cell line has ever been fertile.

### Chromosomal Evaluation

With the revised nomenclature, it is very easy to remember the chromosomal pattern (Table 12.2). The presence of Y fluorescence should alert the clinician for the possible future risks of malignancy.

# Paediatric Oncology

## WILMS' TUMOUR

### Introduction

Wilms' tumour (WT) or nephroblastoma is the most common type of renal malignancy that affects children. It is an embryonal tumour that develops from remnants cells of immature kidney. The condition is named for Carl Max Wilhelm Wilms', a 19th century German surgeon, who wrote one of the first medical articles about the disease in 1899.

### Epidemiology

The overall annual incidence is approximately 8 per million children less than 15 years of age. It accounts for 6–7% of all childhood cancers. The mean age of presentation for unilateral disease is 3.5 years and for bilateral disease, 2.5 years. The tumour presents at an earlier age among boys. The disease occurs with equal frequency in girls and boys worldwide. WT has been linked to various genetic syndromes and birth defects such as:

- WAGR syndrome (WT, aniridia, ambiguous genitalia and mental retardation)
- Beckwith-Wiedemann syndrome (macroglossia, gigantism and umbilical hernia)
- Denys-Drash syndrome (WT, pseudohermaphroditism and glomerulopathy)

Children with these genetic syndromes should be screened for WT every 3 months until the age of 8 years. An ultrasound test may be used for screening.

Wilms' tumour has also been linked to various birth defects such as:

- Hemihypertrophy
- Cryptorchidism
- Congenital aniridia
- Hypospadias

### Pathogenesis

Nephrogenic rests are thought to be precursor lesions to WT. Nephrogenic rests have been defined as a focus of abnormally persistent nephrogenic cells. These rests are found in 1% of unselected paediatric autopsies, 35% of kidneys with unilateral WT and nearly all kidneys with bilateral WT.

It has been postulated that in most people these rests resolve but in some, can give rise to WT.

### Molecular Genetics

Wilms' tumour appears to primarily result from loss of certain tumour suppressor genes as opposed to activation of oncogenes.

Several chromosomal regions have been implicated with development of WT:

- Band 11p13—WT1, WT suppressor gene, may explain associations with WAGR and Denys-Drash syndromes
- Band 11p15—WT2, may explain associations with Beckwith-Wiedemann syndrome.

### Pathology

Wilms' tumours are mostly solitary lesions but can be multifocal in 12% cases.

### Gross Appearance

Uniform pale grey or tan colour on section, but can give a variegated appearance due to haemorrhage and necrosis. They are usually sharply demarcated and are surrounded by a distinct intrarenal pseudocapsule composed of compressed atrophic renal tissue. Cysts are also commonly encountered.

### Histology

Wilms' tumour is composed of three cell types:

1. Blastemal: Undifferentiated small blue cells.



**Fig. 13.1:** Synchronous bilateral Wilms' tumour in a child presenting with abdominal masses

2. Epithelial: Usually seen as abortive glomeruli and tubules.
3. Stromal: Usually as immature spindled cells or can manifest as cartilage, osteoid or fat.

Depending on presence of different types of cell types Wilms' can be termed as triphasic or monophasic.

Wilms' tumour can be separated into two prognostic groups on the basis of histopathology:

1. Favourable histology (FH): Absence of anaplasia in the tumour is considered as FH.
2. Unfavourable/Anaplastic histology (UFH): Presence of markedly enlarged polypoid nuclei within tumour samples. Anaplasia is associated with resistance to chemotherapy and may still be detected after preoperative chemotherapy. Anaplasia is found in 5% of tumours.

### Clinical Presentation

Most children are brought to medical attention due to an abdominal mass (Fig. 13.1). Other frequent symptoms at diagnosis are abdominal pain, fever and haematuria. Hypertension may also be present in 25% of children with WT.

The child may also present with acute abdomen due to rupture of the tumour in the peritoneal cavity.

On examination, the mass is examined with serious efforts to recognise signs suggestive of associated syndromes. Varicocele may be present due to obstruction of spermatic veins due to tumour thrombus in the renal vein or inferior vena cava (IVC), on left side.

### Investigations

#### Laboratory Studies

- Complete blood count
- Basic metabolic profile
- Coagulation assay (acquired von Willebrand's disease in 8% patients)
- Urinalysis

#### Imaging Studies

- Ultrasound
  - Initial diagnosis of a renal or abdominal mass, possible renal vein or IVC thrombus, information regarding liver and other kidney.
- Computed tomography scan
  - Differential diagnosis of a kidney tumour versus adrenal tumour (neuroblastoma)
  - Liver metastases
  - Status of opposite kidney (7% patients have bilateral WT)
  - Lymph node assessment
  - Status of chest with respect to metastases
  - Renal vein or IVC thrombus (6% of cases have IVC thrombus).
- Chest X-ray—as a baseline for pulmonary metastases
- Bone scan/skeletal survey—routinely not done in all cases of WT. Indicated in the cases of pulmonary or hepatic metastases, and in patients with symptoms suggestive of bone involvement.

#### Histology

In National Wilms' Tumour Study Group (NWTSG) protocol, patient is explored at presentation if resectable, then nephrectomy specimen or if unresectable, a biopsy is submitted for histopathological examination for assessing the FH and UFH.

#### Staging

National Wilms' Tumour Study Group staging for renal tumours:

**Stage I:** The tumour is limited to the kidney and has been completely excised. The renal capsule and the tumour are not ruptured. The vessels of the renal sinus are not involved and there is no residual tumour after surgical resection.

**Stage II:** The tumour extends beyond the kidney but was completely resected. There is regional extension of the tumour (i.e. penetration of the renal capsule, extensive invasion of the renal sinus). Blood vessels outside the renal sinus may contain

tumour (tumour thrombus or infiltration). The tumour may have been biopsied, or there was local spillage of tumour confined to the flank. There is no evidence of tumour at or beyond the margins of resection. Free-floating IVC thrombus.

*Stage III:* Residual non-haematogenous tumour confined to the abdomen or any of the following: Lymph node involvement in the hilum or pelvis, diffuse peritoneal spillage either before or during surgery, peritoneal implants, tumour beyond the surgical margin either grossly or microscopically tumour not completely resected because of local infiltration into vital structures, IVC thrombus that is adherent to the vena caval wall, tumour infiltrating a cuff of bladder.

*Stage IV:* Haematogenous or lymph node metastasis has occurred outside the abdomen or pelvis.

*Stage V:* Synchronous bilateral involvement has occurred. Each side is assigned a stage from I to III, and histology is based on biopsy findings.

The most common sites of metastases are lung, regional lymph nodes and liver.

## Treatment

Multidisciplinary treatment planning by a team of cancer specialists (paediatric surgeon or paediatric urologist, paediatric radiation oncologist and paediatric oncologist) with experience in treating WT is required to determine and implement optimum treatment.

Important treatment protocols are as follows:

1. National Wilms' Tumour Study Group: Surgery and staging are done at presentation, and treatment is decided according to the staging.
  2. Société Internationale d'Oncologie Paedia-trique (SIOP): Upfront chemotherapy is given at presentation. After few cycles of chemotherapy staging is done and future treatment is decided.
- United Kingdom Children's Cancer and Leukaemia Group (UKCCLG): Diagnostic biopsy is done then chemotherapy is given.

## Surgical Principles

According to the NWTSG protocol, the first step in the treatment of WT is surgical staging followed by radical nephrectomy via transabdominal route. Following points are to be remembered while operating on WT:

- Accurate assessment of the extent of disease for staging and to assess resectability
- Complete tumour removal without rupture
- Contralateral kidney must be palpated and inspected
- Lymph node sampling is mandatory
- Margins of resection and residual tumour should be marked with titanium clips

Nephrectomy is not done (only staging and biopsy done) in following circumstances:

- Solitary kidney
- Bilateral WT
- Unresectable tumour
- Poor general condition of patient (high operative morbidity and mortality)
- IVC thrombus extending above the level of hepatic veins.

Chemotherapy is given for 5 weeks, after which patient is reassessed for resectability. In the author's experience, fine needle aspiration cytology (FNAC) has been practised routinely over decades without any untoward effects. The diagnostic accuracy in expert hands is high. Supplementation with immunocytochemistry helps to rule out other round cell tumours in cases with diagnostic dilemmas. An open, biopsy for histopathological confirmation, in cases appearing unresectable clinically, may not be needed if facilities for FNAC are available.

## Chemotherapy

Depending upon the stage and histopathology, the chemotherapy regime is charted:

- Regimen EE4A: 18-week course of actinomycin-D and vincristine
    - All stage I and stage II FH tumours
  - Regimen DD4A: 24-week course of actinomycin-D, vincristine, doxorubicin
    - Stage III-IV FH WT and stage II-IV focal anaplasia
  - Regimen I: 24-week course of vincristine, doxorubicin, cyclophosphamide, etoposide
    - Stage II-IV diffuse anaplasia
- The dose in infancy should be decreased by 50%.

## Radiotherapy

Wilms' tumour is a highly radiosensitive tumour. Higher doses were used in the past, but documentation of radiation related side effects has led to decreases in radiation doses.

Indications of radiotherapy are:

- Stage II, III and IV with UFH
  - Stage III and IV with FH
  - Metastatic disease (to metastatic site)
    - Abdominal irradiation 1080 cGy in 6 fractions
    - Lung irradiation 1200 cGy in 9 fractions (> 18 m)
- Patients in age younger than 18 months are given radiation only if there is no response to chemotherapy, 900 cGy in 6 fractions with 150 cGy supplementation to the metastases.

## Prognostic Factors

The most important adverse prognostic factor is the presence of anaplasia. Other prognostic factors are regional lymph node involvement and presence of metastases.



## Follow-Up

All patients are reviewed every 3 months for the first year, and then every 6 months for another 2 years. During each of the follow ups in the first 3 years it is recommended to get a radiological evaluation. This may be an ultrasound or CECT scan in addition to a chest X-ray. The likelihood of recurrence after the first 3 years is less; however, these patients should be followed up every year for various long-term complications.

## Complications

### Surgical Complications

- Small bowel obstruction (7%)
- Haemorrhage (6%)
- Wound infection, hernia (4%)
- Vascular complications (2%)
- Splenic and intestinal injury (1.5%)

### Long-Term Complications

**Renal function:** The rate of chronic renal failure (CRF) is 1% overall. Of these cases, 70% are children with bilateral WT. In unilateral WT, the rate is 0.25%. The most common cause of CRF is the treatment-related cause such as surgery or radiation. Unrecognised renal disease, such as Denys-Drash syndrome, is rare. The damage produced by radiation is dose-dependent, and the rate of impaired creatinine clearance is approximately 20% with total abdomen irradiation with less than 1,200 rads.

**Cardiac function:** The fact that anthracyclines, such as doxorubicin produce cardiac muscle impairment in 5% of those receiving a cumulative of 400 mg/m<sup>2</sup> is well known. The overall incidence rate of some form of cardiac damage is 25% in those treated with anthracycline. Overall incidence of cardiac failure is 1.7%. The mean time to the onset of cardiac failure is 8 years.

**Pulmonary function:** Radiation pneumonitis is encountered in 20% of the cases receiving total pulmonary radiation. The rate of diffuse interstitial pneumonitis with varicella and pneumocystis infection is 13%.

**Hepatic function:** Actinomycin-D and radiation may damage the liver. Hepatic veno-occlusive disease (VOD) is a clinical syndrome of hepatotoxicity and consists of jaundice, ascites, hepatomegaly and weight gain.

**Gonadal function:** Chemotherapy may affect gonadal function in boys but rarely affects the function of ovaries. Abdominal irradiation may induce ovarian failure if ovaries are in the target field.

**Musculoskeletal function:** Clinical rickets is possible due to renal tubular Fanconi's syndrome caused by drugs that are too cytotoxic. Skeletal sequelae of radiation, including

scoliosis or kyphosis, result from uneven growth when the radiation is unilaterally targeted to the vertebral bodies and the dose is higher than 2,000 rads.

**Second malignant neoplasm:** These may result from inherited disposition and treatment, bone tumours, breast cancer and thyroid cancer. The rate after a medium follow-up of 15 years is 1.6%, which is 5 times the expected rate. Limiting the intensive chemotherapy and radiotherapy and reserving the intensive treatment regimens only for the high stages and the cases with UFH possibly can limit second malignant neoplasm.

## Prognosis

The outcome of 202 cases seen in last 17 years, the survival rate was 95% for stage I and II tumours, 75% for stage III tumours, 62% for stage IV tumours and 40% for stage V tumours. The number of cases stage-wise was stage I—19.3%, stage II—15.8%, stage III—43.0%, stage IV—15.3% and stage V—6.4%.

## NEUROBLASTOMA

### Introduction

Neuroblastoma is the most common extracranial solid tumour in children, accounting for 8–10% of all childhood cancers. Neuroblastoma is exclusively a paediatric neoplasm and is the most common cancer diagnosed during infancy. It is a malignancy of the sympathetic nervous system arising from neuroblasts (pluripotent sympathetic cells).

### Epidemiology

Incidence of neuroblastoma is approximately 8–10 per million children younger than 15 years. It is marginally more common in boys than in girls, with a male to female ratio of 1.1:1.0. The mean age at diagnosis is 17.3 months.

### Aetiology

Neuroblastoma develops from postganglionic sympathetic neuroblasts. Microscopic neuroblastic nodules are usually present in adrenal gland of all foetuses. These nodules peak at 17–20 weeks of gestation and regress by the perinatal period. Although these nodules probably represent the remnants of normal adrenal development, nevertheless, they represent cells from which neuroblastoma develops.

These tumours frequently have features of neuronal differentiation. Neuroblastomas may occasionally show spontaneous differentiation to ganglioneuroblastoma or ganglioneuroma.

### Genetics

The most important genetic abnormality of prognostic significance is gene amplification of MYCN protooncogene

present on short arm of chromosome 2. More than 10 copies of MYCN are associated with poor prognosis. Approximately 25% of patients with neuroblastoma exhibit MYCN amplification.

Deletion of the short arm of chromosome 1 is the most common chromosomal abnormality present in neuroblastomas, and it confers a poor prognosis. The 1p chromosome region likely harbours tumour suppressor genes or genes that control neuroblast differentiation. Neuroblastomas also exhibit deletions of 11q, 14q and unbalanced gain of 17q.

Total content of DNA in cell as measured by flow cytometry is also of prognostic significance in infants. Hyperdiploid tumours (DNA index > 1) have better prognosis as compared to diploid tumours.

Three neurotrophin receptor gene products – TrkA, TrkB and TrkC – are tyrosine kinases that code for a receptor of members of the nerve growth factor (NGF) family. It has been demonstrated that TrkA expression is inversely correlated with MYCN amplification.

## Pathology

Neuroblastoma falls into the broader category of small round blue cell neoplasms of childhood. The classic histopathologic patterns of neuroblastoma, ganglioneuroblastoma and ganglioneuroma reflect a spectrum of maturation and differentiation.

Neuroblastoma is composed of small uniform cells with scant cytoplasm and hyperchromatic nuclei. The presence of neuropil and Homer-Wright pseudorosette are diagnostic of neuroblastoma. These pseudorosettes, observed in 15–50% of tumour samples can be described as neuroblasts surrounding eosinophilic neuritic processes.

Ganglioneuroma on the other hand is composed of mature ganglion cells, neuropil and Schwannian cells.

Ganglioneuroblastoma comprises tumours with histology spanning the extremes of ganglioneuroma on one hand and neuroblastoma on other.

Light microscopy is frequently unable to differentiate neuroblastoma from other small blue round cell tumours. Immunohistochemistry with NSE, chromogranin, synaptophysin and S-100 stains usually are positive. Electron microscopy can be useful because ultrastructural features like presence of microfilaments, microtubules and dense core granules are diagnostic for neuroblastoma.

Earlier Shimada and Joshi pathological classification was in use but now International Neuroblastoma Pathology Classification (INPC) that combines the best features of these two systems has been developed. The tumours are divided into those with favourable and unfavourable histopathology depending upon histology, age and mitosis-karyorrhexis

index (MKI). Mitosis-karyorrhexis index is defined as total number of necrotic tumour, mitotic cells and cells with lobulated, pyknotic or malformed cells per 5,000 cells examined.

### *Favourable Histopathology*

- Any age, ganglioneuroma, maturing or mature
- Any age, ganglioneuroblastoma, intermixed
- Less than 1.5 years old, neuroblastoma, poorly differentiated or differentiating and low or intermediate MKI
- From 1.5 years up to less than 5 years old neuroblastoma differentiating and low MKI.

### *Unfavourable Histopathology*

- Any age, ganglioneuroblastoma, nodular
- Any age, neuroblastoma, undifferentiated and any MKI, or high MKI
- 1.5 years up to less than 5 years old, neuroblastoma, poorly differentiated tumour and any MKI, or intermediate MKI
- Equal to or greater than 5 years old, neuroblastoma, any subtype and any MKI.

## Clinical Features

Because neuroblastoma can arise from any site along the sympathetic nervous system explains the multiple anatomic sites where these tumours occur; location of tumours appears to vary with age. Tumours can occur in the abdominal cavity (40% adrenal, 25% paraspinal ganglia) or involve other sites (15% thoracic, 5% pelvic, 3% cervical tumours, 12% miscellaneous). The signs and symptoms in neuroblastoma reflect the location of primary, regional and metastatic disease.

Most with neuroblastoma have abdominal primaries and present with an asymptomatic abdominal mass that usually is discovered by the parents or a caregiver. Symptoms produced by the presence of the mass depend on its proximity to vital structures and usually progress over time:

- Tumours arising from the paraspinal sympathetic ganglia can grow through the spinal foramina into the spinal canal and compress the spinal cord. This may result in the presence of neurologic symptoms, including motor, sensory deficits and even bladder and bowel dysfunction.
- Tumours may compress the lymphatic or venous drainage resulting in scrotal or lower extremity oedema.
- Sudden enlargement of abdominal mass may be due to haemorrhage into the tumour.
- Thoracic neuroblastomas (posterior mediastinum) may be asymptomatic and usually are diagnosed by imaging studies obtained for other reasons. Presenting signs or symptoms may be insignificant and involve mild

airway obstruction or chronic cough, leading to a chest radiograph. Occasionally they may result in superior vena cava syndrome.

- Thoracic tumours extending to the neck can produce Horner's syndrome. Primary cervical neuroblastoma is rare but should be considered in the differential diagnosis of masses of the neck, especially in infants younger than 1 year with feeding or respiratory difficulties.

Metastatic extension of neuroblastoma occurs by both haematogenous and lymphatic routes. Haematogenous spread occurs most often to bone, bone marrow, liver and skin.

- Extensive metastases to liver may result in respiratory compromise.
- Metastases to bone may cause bone pain and limping. Periorbital ecchymosis and proptosis secondary to metastatic disease to the orbits may be the presenting complaint. The presence of bone metastases can lead to pathologic fractures.
- Skin involvement especially in infants with stage 4S is characterised by variable number of non-tender bluish subcutaneous nodules. Blueberry muffin baby is the term sometimes to describe extensive involvement of skin.
- Symptoms of bone marrow failure (anaemia, bleeding and infection) may be present if there is extensive involvement of bone marrow.

Minority of patients may present with paraneoplastic syndromes.

- Opsomyoclonus: Child presents with myoclonic jerking and random eyeball movements. Antineural antibodies against the tumour may cross react with neurons in cerebellum and may cause opsomyoclonus.
- Secretory diarrhoea and hypokalaemia may be the manifestation of tumour secretion of vasoactive intestinal peptide (VIP).

Constitutional symptoms like fever and failure to thrive may be the presenting complaint.

## Investigations

### Laboratory Investigations

- Complete blood counts
- Basic metabolic panel
- Urinary catecholamines: Increased levels are detected in 90–95% of neuroblastomas patients. Urinary homovanillic acid (HVA), metabolite of DOPA and dopamine, and vanillylmandelic acid (VMA), metabolite of norepinephrine and epinephrine are measures. 24-hour measurements are preferred as compared to spot samples. Higher HVA/VMA is associated with less differentiated tumour.

### Other Investigations

Imaging is required to know the origin and extent of disease. CT or MRI is done to determine the extent of primary.

Metastases are common in neuroblastoma, therefore, possible sites of metastases are investigated to rule out involvement:

- Bone: Skeletal survey and bone scan (technetium 99)
- Bone marrow: Bilateral bone marrow aspiration and biopsy from posterior superior iliac spine. Single positive study is enough to diagnose bone marrow metastases
- Abdominal imaging with CT or MRI
- Chest radiograph—AP and lateral. Chest CT is only done if chest radiograph is abnormal or abdominal tumour extends into the chest.

MIBG (methyl iodobenzylguanidine) scintigraphy: MIBG accumulates in catecholaminergic cells including most neuroblastomas and provides a specific way of identifying primary and metastatic disease if present.

Positron emission tomography (PET) scan is a new modality which has been found useful to study of chemotherapy on these patients (Figs 13.2A and B).

### Diagnostic Criteria

Diagnosis of neuroblastoma is established if:

- An equivocal pathological diagnosis is made from tumour tissue by light microscopy, with or without immunohistology, electron microscopy, or increased urine catecholamines or metabolites; or
- Bone marrow aspirate or biopsy containing unequivocal tumour cells, and increased urine catecholamines or metabolites.

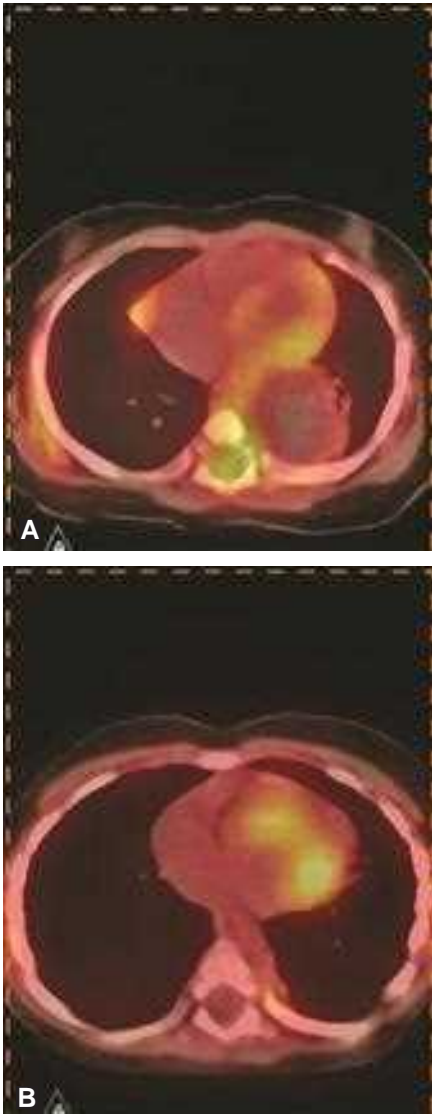
### Staging

Earlier multiple staging systems were in use. International Neuroblastoma Staging System (INSS) was developed to make the staging of neuroblastomas around the world.

*Stage 1:* Localised tumour with complete gross excision, with or without microscopic residual disease; representative ipsilateral lymph nodes negative for tumour microscopically (i.e. nodes attached to and removed with the primary tumour may be positive).

*Stage 2A:* Localised tumour with incomplete gross excision; representative ipsilateral non-adherent lymph nodes negative for tumour microscopically.

*Stage 2B:* Localised tumour with or without complete gross excision, with ipsilateral non-adherent lymph nodes positive for tumour. Enlarged contralateral lymph nodes must be negative microscopically.



**Figs 13.2A and B:** PET scan of a baby with neuroblastoma: (A) Pre-chemotherapy; (B) Post-chemotherapy

**Stage 3:** Unresectable unilateral tumour infiltrating across the midline, with or without regional lymph node involvement; or localised unilateral tumour with contralateral regional lymph node involvement; or midline tumour with bilateral extension by infiltration (unresectable) or by lymph node involvement. The midline is defined as the vertebral column. Tumours originating on one side and crossing the midline must infiltrate to or beyond the opposite side of the vertebral column.

**Stage 4:** Any primary tumour with dissemination to distant lymph nodes, bone, bone marrow, liver, skin and/or other organs, except as defined for stage 4S.

**Stage 4S:** Localised primary tumour, as defined for stage 1, 2A or 2B, with dissemination limited to skin, liver and/or bone marrow (limited to infants younger than 1 year). Marrow involvement should be minimal, i.e. less than 10% of total nucleated cells identified as malignant by bone biopsy or by bone marrow aspirate. More extensive bone marrow involvement would be considered to be stage 4 disease.

### Prognostic Factors

- Age: Infants have better prognosis than older children
- Early stage of disease (I and II) is better
- Tumour site: Cervical neuroblastomas have better prognosis, may be due to their early detection. Pelvic and thoracic tumours carry a better prognosis than abdominal tumours
- Cortical bone involvement is associated with poor prognosis
- Tumour pathology: Favourable or unfavourable as determined by (INPC).

### Genetic Markers

- MYCN amplification
- Hyperdiploid karyotype
- 1p loss of heterozygosity
- TrkA.

### Treatment

#### Principles of Surgery

Surgery plays an important role in the diagnosis and management of neuroblastoma.

Advances in chemotherapy have made sacrifice of vital structures during resection, unnecessary. Gross complete resection should be attempted if possible. Non-adherent, intracavitary lymph nodes should be sampled. Role of random liver biopsy to rule out hepatic metastases is controversial. Liver biopsy is still indicated in infants as imaging studies may miss diffuse involvement of liver.

#### Principles of Radiotherapy

Neuroblastoma is a radiosensitive tumour. Role of radiotherapy in management of neuroblastoma is clearly defined in following setting:

- Infants with stage 4S disease who present with respiratory distress secondary to hepatomegaly and have not responded to chemotherapy
- Total body irradiation is used as a part of many preparative regimens for autologous bone marrow transplant

- To decrease spinal cord compression in patients with intraspinal extension of tumour, who present with neurological symptoms
- Treating problematic metastatic disease at diagnosis
- Palliative management of pain in end-stage disease

Role of radiotherapy in patients with locoregional disease is not well defined. Use of more dose intensive chemotherapy has made routine use of radiotherapy questionable. Radiotherapy may still be of benefit in patients whose tumour has responded incompletely to both chemotherapy and attempted resection and also has unfavourable biologic characteristics.

### *Principles of Chemotherapy*

In patients of intermediate or high-risk neuroblastoma chemotherapy is the predominant modality of treatment. Drugs used in treatment of neuroblastoma are cyclophosphamide, cisplatin, doxorubicin and etoposide. Other drugs useful or under investigation are ifosfamide, carboplatin, irinotecan and topotecan.

### *Risk-Related Treatment*

Prognostic factors may determine the clinical behaviour of the tumour. Thus, most oncology study groups now divide the patients according to their risk groups. The COG risk stratification system has been developed from more than two decades of experience with clinical trials in Children's Cancer Group (CCG) and Paediatric Oncology Group (POG).

### *Treatment of Low-Risk Disease*

Surgery alone is effective as initial therapy in stage 1 and 2 neuroblastoma. Recurrences are often salvageable with surgery.

Treatment for rare subset of these patients with MYCN amplification needs further evaluation, as relapses are frequent after surgery.

In patients with stage 4S neuroblastoma, resection of primary tumour does not affect the outcome. Patient with respiratory distress secondary to hepatomegaly are treated initially with chemotherapy.

### *Treatment of Intermediate Risk Disease*

Chemotherapy is the predominant modality for treatment of neuroblastoma. Cyclophosphamide, cisplatin, doxorubicin and etoposide are given for 12–24 weeks. Surgical resection of residual disease is done. Radiotherapy is reserved for patients with progression despite surgery and chemotherapy or for patients with unfavourable features and unresectable primary tumour after chemotherapy.

### *Treatment of High-Risk Disease*

Neuroblastoma is typically sensitive to initial chemotherapy so patients are given induction chemotherapy consisting of very high doses of cyclophosphamide, cisplatin, doxorubicin and etoposide with the goal of causing maximum reduction in tumour bulk. After a response to chemotherapy, resection of the primary tumour should be attempted, followed by myeloablative chemotherapy, sometimes total-body radiation, and autologous stem cell transplantation. Due to significant improvements in time to recovery and a lower risk of tumour cell contamination, most centres now recommend the use of peripheral blood stem cell support over bone marrow for consolidation therapy. Finally therapy against minimal residual disease is started with the goal of eradicating this chemoresistant residual disease by using agents, which are not typically cytotoxic.

Patients are treated with oral 13-cis-retinoic acid for 6 months. Retinoids are helpful by promoting cellular differentiation with decrease in proliferation of neuroblastoma cells.

### **Prognosis and Survival**

The 5-year survival rates are approximately 80% for infants, 50% for children 1–5 years and 40% for children older than 5 years. Children with disseminated disease have a high mortality rate. The 3-year event-free survival for high-risk patients treated with conventional chemotherapy, radiotherapy and surgery is less than 20%. Bone marrow transplantation has been found to improve survival.

## **RHABDOMYOSARCOMA**

### **Introduction**

Rhabdomyosarcoma (RMS) is the most common soft tissue tumour in children. It is a ubiquitous tumour occurring almost everywhere but most commonly in the head and neck, testis and the genitourinary (GU) areas (Fig. 13.3). RMS is the third most common neoplasm after neuroblastoma and WT, comprising 15% of all extracranial paediatric solid tumours. Multimodal treatment approach, risk-adapted therapy, refinements in tumour grouping and better supportive care have resulted in good survival rates with 73% children having failure-free survival for more than 3 years.

### **Epidemiology**

Annual incidence of RMS in children less than 20 years of age is 4–5 cases per million children. Almost two-thirds of cases of RMS are diagnosed in children less than 6 years



Fig. 13.3: Submandibular rhabdomyosarcoma

of age although there is another mid-adolescence peak. It is slightly more common in males than in females (1.3–1.4:1).

### Aetiology

Majority of cases of RMS occur sporadically, but few cases have also been associated with some familial syndromes like Li-Fraumeni syndrome and neurofibromatosis.

### Molecular Biology

In the last decade, specific genetic alterations associated with the development of this tumour have been uncovered.

The two major histologic subtypes of RMS, i.e. embryonal RMS (ERMS) and alveolar RMS (ARMS) are associated with characteristic but distinct genetic alterations.

ARMS have a translocation between long arms of chromosome 2 and 13:  $t(2;13)(q35;q14)$  or between chromosomes 1 and 13 which generate PAX3-FKHR and PAX7-FKHR fusion proteins respectively. ERMS have allelic loss at chromosome 11p15.5.

The most common oncogene abnormalities observed in RMS are RAS mutations.

### Pathology

#### Gross Appearance

Rhabdomyosarcomas are grossly firm, nodular and of variable size and consistency. They are well circumscribed but not encapsulated and often tend to infiltrate extensively into adjacent tissues. Sarcoma botryoides subtype has

characteristic grape-like appearance with its grape-like clusters of tumours arising from a mucosa-lined area.

### Histology

Rhabdomyosarcoma falls into the broader category of small round blue cell neoplasms of childhood. The characteristic feature that helps in characterising the tumour, as RMS is identification of skeletal myogenic lineage, which can be done in following ways:

- Light microscopy: Presence of cross-striations or characteristic rhabdomyoblast
- Immunohistochemistry: Muscle-specific proteins, like desmin, muscle-specific actin, myosin, myoglobin, Z-band protein and MyoD, can be identified by immunohistochemical staining
- Electron microscopy: Identification of actin-myosin bundles or Z-band

RMS was traditionally classified by Horn and Enterline in 1958. Due to lack of consensus between pathologists, it led to development of a new International Classification of RMS, which was reproducible and prognostically useful. RMS was classified as follows:

1. Superior prognosis
  - Botryoid
  - Spindle cell
 Both uncommon variants of ERMS
2. Intermediate prognosis
  - Embryonal
3. Poor prognosis
  - Alveolar
  - Undifferentiated

Embryonal RMS: Stroma rich, spindle cell appearance, less dense and no evidence of alveolar pattern. *Botryoid type* has characteristic appearance of tumour layer under the epithelium. *Spindle cell* type has characteristic spindle-shaped cells with abundant collagen in between them. Approximately two-thirds of newly diagnosed RMS belongs to the embryonal type.

Alveolar RMS: Presence of any alveolar pattern. Small round cells, densely packed.

### Clinical Features

#### Site of Primary

- Head and neck – 35%
  - Parameningeal – 16%
  - Orbit – 9%
  - Other head and neck – 10%
- Genitourinary – 22%
- Extremity – 18%
- Others (trunk, intrathoracic, perineal, biliary tract) – 25%

### Presentation

Some typical presentations by location of non-metastatic disease are as follows:

- Orbit—Proptosis or dysconjugate gaze
- Paratesticular—Painless scrotal mass
- Prostate—Bladder or bowel difficulties
- Uterus, cervix and bladder—Menorrhagia or metrorrhagia
- Vagina—Protruding polypoid mass (botryoid, meaning a grape-like cluster)
- Extremity—Painless mass
- Parameningeal (ear, mastoid, nasal cavity, paranasal sinuses, infratemporal fossa, pterygopalatine fossa)—Upper respiratory symptoms or pain.

### Pattern of Spread

Nearly 25% of newly diagnosed cases have distant metastases with most of them having a single site involvement. The lung is the most common site of metastases (50%). Other sites of involvement are bone marrow, bone and lymph node.

### Investigations

#### Laboratory Studies

- Complete blood count
- Basic metabolic profile

#### Imaging Studies

- Plain X-ray films of affected part
- Skeletal survey
- Bone scan
- Computed tomography scan
- Magnetic resonance (especially for head and neck, and extremity tumours)

#### Histology

- Incisional or excisional biopsy is taken and submitted for histopathological examination
- Bilateral bone marrow aspiration and biopsy may also be done.

#### Staging

Following two staging systems are currently employed in combination:

1. Clinical group staging system:
  - Group I—Tumour completely removed
  - Group II—Microscopic residual tumour, involved regional nodes or both
  - Group III—Gross residual tumour
  - Group IV—Distant metastatic disease
2. TNM staging system:

- Tumour—Confined to the site of origin (T1); extends beyond the site of origin (T2)
- Node—No regional node involvement (N0); regional node involvement (N1); nodes unknown (NX)
- Metastasis—No metastasis (M0); metastases present at diagnosis (M1)
- Stage 1—Orbit, head/neck (not parameningeal) and GU tract (not bladder/prostate)
- Stage 2—Other location: N0 or NX
- Stage 3—Other location: N1 (if tumour < 5 cm), N0 or NX (if tumour > 5 cm)
- Stage 4—Any site with distant metastases

### Treatment

Multimodal approach for treating RMS has resulted in better survival rates.

Various treatment protocols are in use for treatment of RMS:

- Intergroup RMS study (IRS): First study in 1972. Treat cases with aggressive surgery, routine RT and prolonged chemotherapy for up to 2 years.
- Malignant mesenchymal tumour study (MMTS): Non-radical surgery or biopsy followed by chemotherapy. RT omitted if complete remission.

### Surgery

Complete surgical excision has been the cornerstone of treatment. Now with multimodal (chemo + RT + surgery) therapy local control rates of 95%. Surgery has evolved with avoidance of mutilating procedures and stress on organ preservation. There is no role of tumour debulking. Lymph node sampling is only necessary in extremity RMS.

#### *Surgical Principles: Head and Neck*

Non-surgical treatment for orbital RMS is standard. Biopsy followed by chemotherapy and radiotherapy achieves more than 90% survival. Evisceration is reserved for recurrent or residual disease.

Other head and neck lesions are usually treated by biopsy followed by chemotherapy and radiotherapy with resection of the residual disease and reconstruction. Some superficial lesions can be excised primarily.

#### *Surgical Principles: Bladder and Prostate*

Partial cystectomy is done for lesions at the dome of bladder, sarcoma botryoides that is pedunculated and excision of residual nodule. Bladder can usually be preserved without compromising survival rates. Cystectomy must be resorted to when adjuvant therapy fails.

Intracavitary radiotherapy has revolutionised treatment of these cases.

### *Surgical Principles: Paratesticular Rhabdomyosarcoma*

Radical inguinal orchidectomy is done and if scrotal violation is also there then hemiscrotectomy is also done. Retroperitoneal lymph node dissection is unnecessary in less than 10 years old in which excellent cure rate can be achieved with chemotherapy. In children older than 10 years, modified retroperitoneal lymph node dissection is done.

### *Surgical Principles: Vagina/Uterus/Vulva*

Biopsy followed by chemotherapy and radiotherapy with limited resection or partial vaginectomy for the residual disease. Hysterectomy is only rarely required.

### *Surgical Principles: Extremities*

Limb sparing wide local excision (2 cm margins) and regional LN biopsy is done. Amputation is rarely done and reserved for:

- Neurovascular bundle involvement
- Local recurrence
- Skeletally immature child
- Pain control in weight bearing limbs.

### **Chemotherapy**

Vincristine, actinomycin-D and cyclophosphamide (VAC) are the gold standard for combination chemotherapy. Chemotherapy is usually given for 52 weeks.

Low risk cases (Clinical group 1/2 orbit or eyelid and clinical group I paratesticular RMS) only vincristine and actinomycin-D (VA) given for 32 weeks is sufficient.

In infants the dose is decreased by half.

### **Radiotherapy**

RMS is a radiosensitive tumour; therefore, radiotherapy is important in achieving local control. In clinical group II and stage 3 clinical group I cumulative dose of 41.4–45.0 Gy and in clinical group III, 50.4–54.0 Gy is given. This is given in daily fractions of 180–200 cGy. Treatment field comprises initial pretreatment tumour volume with a 2 cm margin. Actinomycin-D is stopped during radiotherapy.

With some exceptions radiotherapy is started after 9–12 weeks of chemotherapy.

### **Prognostic Factors**

Presence of metastases is the most important prognostic factor. Other prognostic factors are site (orbit having best prognosis), histology, surgical resectability and age of the child. Overall in non-metastatic disease a 3-year failure-free survival rate of 76% can be achieved.

## **HEPATOBLASTOMA**

### **Introduction**

Hepatoblastoma is a form of liver cancer that usually occurs in infants. In contrast to hepatocellular carcinoma (HCC), it arises in an otherwise normal liver. Of all liver masses in children, approximately two-thirds are malignant and of these two-thirds are due to hepatoblastoma.

### **Epidemiology**

Most cases of hepatoblastoma occur in infancy or very young childhood. The incidence of malignant liver tumours in infancy is 11.2 per million and decrease throughout childhood with incidence of 1.5 per million in children less than 15 years.

The mean age of diagnosis is around 19 months with the tumour being more common in boys, ratio of 1.4:1.0–2.0:1.0.

### **Aetiology**

The aetiology of hepatoblastoma is unknown. Hepatoblastoma is linked to a number of genetic syndromes, the most important being Beckwith-Wiedemann syndrome and familial polyposis coli. Other syndromes associated with hepatoblastoma are Li-Fraumeni syndrome, trisomy 18 and glycogen storage disease type I.

There is increased incidence of hepatoblastoma in premature infants; therefore, there is need to determine specific factors related to prematurity which contribute to tumourigenesis as well as need for surveillance of the survivors of extreme prematurity.

### **Molecular Biology**

The most common karyotype changes are extra copies of entire chromosomes most commonly 2 and 20.

### **Pathology**

#### *Gross*

About 80% of hepatoblastoma are solitary with 60% involving the right lobe. They are lobulated tan yellow colour with areas of haemorrhage and necrosis.

### **Histology**

Broadly hepatoblastoma can be classified as epithelial type or mixed epithelial and mesenchymal type.

#### *Epithelial Type (56%)*

- Foetal (31%): Cords of neoplastic hepatocytes smaller than normal cells of foetal liver with nuclear to cytoplasmic ratio.



- Embryonal (19%): Primitive tubules formed by small epithelial cells with minimal cytoplasm.
- Macrotrabecular (3%): Cells grow in trabeculae of 20–40 cells in a repetitive pattern within the tumour.
- Small cell undifferentiated (3%): Uniform population of cells lacking evidence of stromal or epithelial differentiation.

#### Mixed Epithelial and Mesenchymal Type (44%)

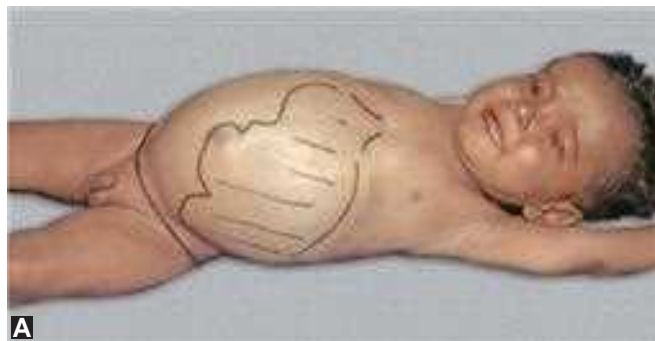
- With teratoid features (10%)
- Without teratoid features (34%).

### Clinical Features

Most patients are asymptomatic at presentation. Asymptomatic mass palpated by either parent or paediatrician is the presenting complaint in 68% of patients. Other presentations are abdominal distension, anorexia, weight loss, abdominal pain and vomiting. Jaundice is rare (Figs 13.4A and B).

### Pattern of Spread

Majority of metastases occur in the lungs. Bone lesions have been reported but they are unclear whether these represent



**Figs 13.4A and B:** Hepatoblastoma of the left lobe of liver: (A) Clinical appearance; (B) Operative findings

true metastases or are areas of demineralisation. Metastases to brain or bone marrow are rare.

### Investigations

#### Laboratory Investigations

- Complete blood counts: Anaemia and thrombocytosis are commonly observed.
- Basic metabolic panel: Liver enzymes are usually normal but may be raised.
- Alpha-fetoprotein (AFP): Levels are increased in more than 80% of cases of hepatoblastoma. AFP is a major serum protein synthesised by fetal liver cells, yolk sacs, and the GI tract. Although elevated AFP levels are not specific for hepatoblastoma, they provide an excellent marker for response to therapy, disease progression and detection of recurrent disease. The half-life of AFP is 5–7 days and levels fall to reference levels 4–6 weeks after complete resection. Interpretation of AFP levels can be difficult because hepatoblastoma tends to occur within the first 2 years of life. Reference range AFP levels are comparatively high at birth and even higher in premature infants, which can complicate interpretation of this value. By age 1 year, adult levels of less than 10 ng/ml have been reached. Hepatoblastomas with very low or very high levels of AFP are associated with poor prognosis.

#### Imaging Studies

- Plain abdominal radiograph: It may reveal right upper quadrant mass and calcification.
- Ultrasound: Homogeneous, encapsulated tumour that may be associated with portal venous or caval invasion
- CT scan of abdomen: Predominantly hypodense lesion with pathological areas of arterialisation. Calcification may be present in 40% cases.
- MRI can also be done instead of CT scan: Low signal on T1 weighted sequences and heterogeneous signal on T2 weighted sequences.
- CT scan of chest: To exclude pulmonary metastases.

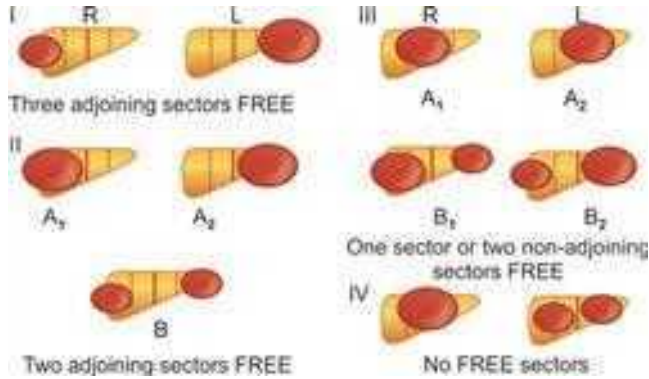
#### Histology

According to Society of Paediatric Oncology Epithelial Liver (SIOPEL) Group diagnosis is usually established on the basis of clinical setting, radiological findings and AFP values, biopsy is recommended in children less than 6 months of age or more than 3 years of age to differentiate from other tumours (hemangiothelioma and hepatic cell carcinoma).

- High-risk case
- Low-risk case

#### Staging

Paediatric oncology group staging of hepatoblastoma:



**Fig. 13.5:** PRETEXT (pretreatment classification scheme), an alternative staging system developed by International Society of Paediatric Oncology

- Stage I (FH): Complete resection with pure foetal histology
- Stage I (UFH): Complete resection with histology other than pure foetal type
- Stage II: Microscopic residual disease, preoperative or intraoperative spill
- Stage III: Unresectable or partially resected tumours, positive lymph nodes
- Stage IV: Metastatic disease.

**PRETEXT** (Pretreatment classification scheme) alternative staging system developed by International Society of Paediatric Oncology based upon number of liver segments involved as determined by preoperative imaging studies. The liver is divided into four sectors—an anterior and a posterior sector on the right and a medial and a lateral sector on the left (Fig. 13.5). Staging is done according to tumour extension within the liver as well as involvement of hepatic vein (v), portal vein (p), regional lymph nodes or distant metastases (m).

## Treatment

Cooperative group trials have enabled development of treatment protocols for treatment of hepatoblastoma. From various studies it is clear that only chance for cure from hepatoblastoma is if sometime during treatment there is grossly complete resection. Most hepatoblastomas, on the other hand, show good response to drugs, which shrinks the tumour thereby increasing the chances of resectability. Principal strategies in treatment of hepatoblastoma are as follows:

- SIOPEL recommends no attempt for primary resection and giving the patient preoperative chemotherapy routinely.
- POG promotes primary resection of tumour at presentation reserving chemotherapy for obviously unresectable tumours.
- German group: Because of concern that resistance may develop after 3–6 courses of chemotherapy and tumour may rapidly develop, primary resection of small localised

tumour is advocated therefore a low resection rate (20%) is observed.

## Surgery

Goal of hepatic tumour resection in general is to completely excise the tumour with at least a 1 cm margin. Anatomical resection is undertaken as they are associated with less intraoperative and postoperative morbidity and mortality. Lymph nodes at porta and hepatoduodenal ligaments are also removed and sampled. There is no significant difference in local tumour recurrence with microscopic positive as against negative margins.

Presence of microscopic residual disease does not necessarily mean a poor prognosis with respect to local tumour recurrence, nor does it imply the need for heroic chemotherapy or surgical salvage procedures. Extrahepatic disease is a more important predictor or outcome than surgical margins.

Orthotopic liver transplantation (OLT) is now accepted as a treatment modality for patients with unresectable tumours. Liver cancers now account for approximately 2% of all liver transplants in children. Early referral to a transplant surgeon should be considered in following situations:

- Multifocal PRETEXT 4 hepatoblastoma
- Large, solitary PRETEXT 4 hepatoblastoma, involving all four sectors of the liver
- Centrally located tumours involving main hilar structures or main hepatic veins

## Chemotherapy

Cisplatin (CDDP) is accepted as the single most useful agent in treatment of hepatoblastoma. Other drugs which are used doxorubicin, 5-fluorouracil, vincristine and carboplatin. Use of irinotecan is under investigation.

## Radiotherapy

Radiotherapy does not play a major role in treatment of hepatoblastoma.

## Prognostic Factors

The most important prognostic factor is complete tumour resection. Other prognostic factors are degree of mitotic activity in tumour cells (more than 2/hpf associated with poor prognosis), pure foetal histology (only if tumour completely resected) and AFP levels at presentation and a fall in response to chemotherapy is good for prognosis.

## HEPATOCELLULAR CARCINOMA

This tumour occurs in older children, usually adolescent. It may present with a palpable hepatic mass, abdominal pain

and rarely jaundice. The serum AFP is raised. In children, HCC can complicate viral hepatitis or metabolic liver disease. It is an aggressive tumour with poor prognosis. It is chemoresistant and is usually advanced at diagnosis. Survival at 3 years is less than 25%.

## GERM CELL TUMOURS

Germ cell tumours account for 2–4% of all malignant diseases in children. They occur in both male and female gonads and occur in a wide variety of paraxial sites. They can be benign or malignant. The importance of these tumours lies in the clearer definition of the role of surgery in treatment. Most malignant tumours are sensitive to chemotherapy and the accuracy of tumour marker measurement is an indicator of the success of treatment. Thus, correct surgical management of testicular tumours results in over 60% cure by orchidectomy alone, saving those patients the risks of permanent effects of the toxicity of chemotherapy. It is also likely that careful attention to surgical detail in the excision of benign sacrococcygeal teratomas in infants may prevent some malignant germ cell tumours.

The age distribution of malignant germ cell tumours as a group reflects the relative frequency of the tumours mentioned above. There is an early peak representing malignant recurrence after excision of sacrococcygeal teratoma in infants, and a later one for the cluster of testicular tumours in males in early puberty.

### Embryology and Pathology

In the normal embryo, germ cells are first identified at 4 weeks in the caudal aspect of the yolk sac wall, having arisen from the endoderm at the neck of the yolk sac (the endodermal sinus). Migration of these cells cephalad to the gonadal ridges is complete by 6 weeks. At this stage, the gonadal ridges extend alongside the vertebral column from cervical to lower lumbar levels. Germ cells which aberrantly migrate further (e.g. to pineal and sacrococcygeal sites) or remain outside the coalescence of gonadal tissue near the developing kidney, may be presumed to lose appropriate growth-regulating influences.

The steps leading to production of benign teratomas and malignant tumours are unknown, but a general explanation in terms of the stage and pathway of differentiation of the germ cell is possible. If it is unipotential, and committed to form gonadal precursors of the gametes, malignant transformation results in the undifferentiated germinoma. The multipotential cell, whether intragonadal or extragonadal, differentiates in a benign form to teratoma and under oncogenic influences to a range of malignant types (Fig. 13.6). It is noted that teratomas predominate in females between birth and 15

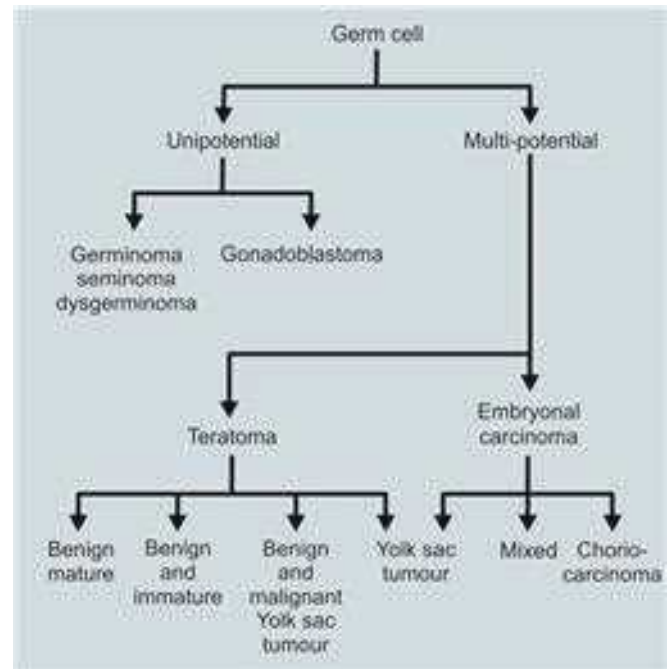


Fig. 13.6: Scheme of relationship in germ cell tumours

years, with a female: male ratio of 7:1 for sacrococcygeal teratomas. This increased susceptibility may be related to pathology in the steps leading to embryonic meiotic activity of germ cells in females.

Further clues to pathogenesis may be found in some well documented risks of malignancy in gonads. Family studies of phenotypic females with 46,XY genotype show a high-risk of gonadal malignant dysgerminoma, so-called 'gonadoblastoma'. In the undescended testis, the increased risk of malignancy is well documented. Premalignant intratubular germ cell neoplasia in an undescended testis has been documented as leading to invasive germ cell malignancy, as well as being found in tubules adjacent to established malignant disease. This appearance is not found in yolk sac tumours in the descended testis of early infancy, including those associated with teratoma. This suggests that maldescent may be associated with an oncogenic influence on the germ cells and a different mechanism operates in the origin of malignant germ cell tumours associated with benign teratoma.

The overlap of histopathological appearances of tumours arising in different sites has led in the past to a confusion of different nomenclatures and ascriptions of the embryological origin of the tissues. Further confusion has arisen from the finding of immature elements in benign teratomas, especially those of the ovary.

Benign teratomas contain mature representation of all three embryonic germ layers. In some ovarian lesions, however, immature neuroectodermal tissue resembling neuroglia may invade outside the teratoma and across the

**Table 13.1:** Histopathology classification of germ cell tumours

Germinoma	<ul style="list-style-type: none"> <li>• Intratubular germ cell neoplasia</li> <li>• Invasive (dysgerminoma, seminoma)</li> </ul>
Teratoma	<ul style="list-style-type: none"> <li>• Mature/Benign</li> <li>• Immature</li> <li>• Malignant (teratoma plus one or more malignant elements)</li> </ul>
Embryonal carcinoma (adult type)	
Endodermal sinus tumour (yolk sac tumour)	
Choriocarcinoma	
Gonadoblastoma	

peritoneum. Metastatic tissue appears nevertheless on microscopy as benign neuroglia.

Of the four main histological types of malignancy, yolk sac tumours (also known as endodermal sinus tumours) are the commonest in early infancy and may occur as malignant foci within an otherwise benign teratoma. Embryonal carcinoma is found in older children and in mixed histology types it coexists with yolk sac tumours. Mixed tumours account for up to a quarter of cases (Table 13.1). Germinomas (testicular seminoma and ovarian dysgerminoma) are relatively rare in children. Choriocarcinoma is very rare, and presents in two forms: (1) the gestational form—in a sexually active teenager and (2) the non-gestational form—which occurs in gonads or in males in extragonadal axial sites.

Though some patterns of chromosomal abnormalities have been identified in germ cell tumours, none so far has formed the basis of a prognostic test, except that aneuploidy is an unfavourable sign.

Malignant germ cell tumours are aggressive neoplasms with local invasive spread occurring early in instances of ovarian and mediastinal primaries. Testicular tumours in contrast often present clinically while still localised to their organ of origin. Metastatic spread is found in 20% of patients at presentation, in either regional lymph nodes or via haematogenous spread to the lungs or occasionally the liver.

### Tumour Markers

Alpha-fetoprotein, first identified as a serum marker of liver tumours, is in clinical practice almost invariably secreted to high levels by malignant germ cell tumours, a serum level greater than 100,000 ng/ml being common. AFP is a glycoprotein with a serum half-life of about 5.5 days. The foetal and neonatal liver secretes AFP in large

quantities and newborn levels of 50,000 ng/ml are normal with still higher levels noted in premature infants. Marked variability of the rates of fall in the first 4 months of life makes interpretation of changes of serum AFP difficult in this era. After the 8th month of life, levels remain low at less than 20 ng/ml. After infancy, the expected fall after total removal of a secreting tumour is easily plotted on a logarithmic chart, and any deviation from this line is considered evidence of residual or recurrent disease (Fig. 13.7). Similarly, any elevation of the serum AFP level after removal of a benign teratoma is evidence of growth of a malignant yolk sac tumour.

Beta-human chorionic gonadotrophin ( $\beta$ -HCG) is secreted by some embryonal carcinomas and germinomas and is presumed to arise from cells simulating syncytiotrophoblast.  $\beta$ -HCG is not associated with yolk sac tumours, but may be positive in instances of mixed tumour, from the embryonal carcinoma element. It is invariably present in patients with choriocarcinoma. Logarithmic graph with an even steeper slope than AFP can be constructed for monitoring the progress of patients with tumours secreting this tumour marker.

Some central nervous system (CNS) germ cell tumours secrete markers, either AFP or  $\beta$ -HCG. An international study showed that there was correlation between tumour markers and histology in only 48% of patients. Elevation of cerebrospinal fluid (CSF) levels of markers over a simultaneous serum sample give a good indication of the nature of a tumour seen on imaging or of recurrence of known tumour within the CNS after initial treatment.

In the great majority of patients, treatment regimes are closely linked to the behaviour of the serum tumour markers, particularly AFP. Excellent results have been reported without using chemotherapy where operative excision of the tumour alone results in permanent return of serum AFP levels to normal. Furthermore, metastases or residual tumour discovered by a deviation from the expected fall of AFP do not require an extensive search by imaging or surgery. After treatment with chemotherapy, confirmation of normal AFP levels continues until there is no significant risk of recurrence.

### Staging

Stage I tumours are confined on histopathology to within the excised specimen provided there is no convincing evidence on imaging of regional lymph node enlargement. Stage IV represents haematogenous spread, usually to lungs, but also to liver, bone, brain and skin. Stages II and III relate to lymph node or cavitory spread near to the primary site or further distant, but not crossing the diaphragm.

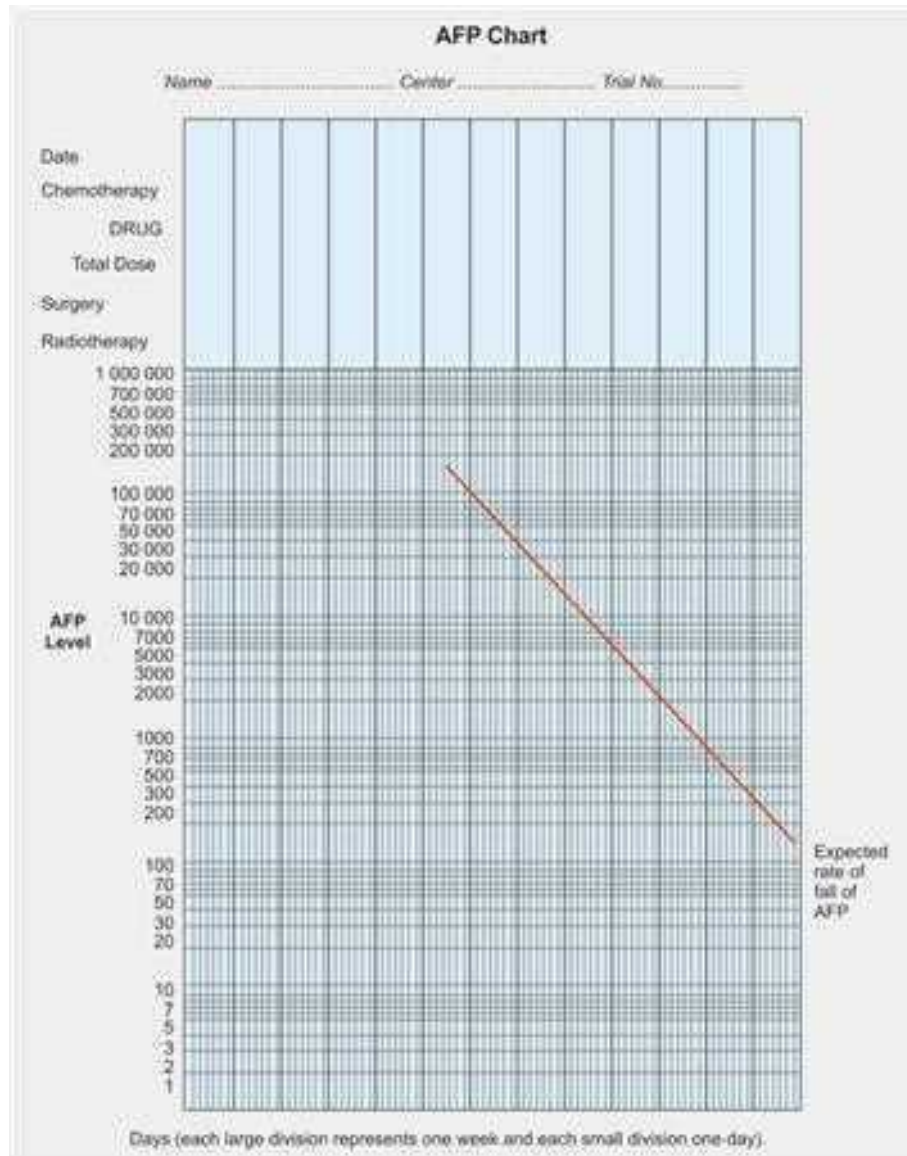


Fig. 13.7: Logarithmic chart for plotting the fall of AFP during treatment

## Clinical Presentation, Investigation and Management

### Testis

The finding of a painless and hard enlargement of a previously normal testis is the commonest presentation. In most cases the obvious change in testicular size and consistency leads to medical intervention before local invasion or distant metastases have occurred. In the absence of pain, the differential diagnosis includes other malignancies, particularly paratesticular RMS and testicular involvement in leukaemia.

Serum AFP levels should be measured urgently and a chest radiograph should be obtained to exclude metastases.

Ultrasound examination of the retroperitoneal tissues, both iliac and at the level of the renal vessels, will detect significant enlargement of lymph nodes. An abdominal CT study is more accurate in assessing the lymph node presence and status. Except for a complete blood count, other investigations are not justified, since removal of the tumour and histological examination of the whole testis and inguinal cord should be carried out promptly.

Trans-scrotal biopsy or any scrotal incisions are contraindicated. A groin incision is made which should be

wider than for herniotomy. The inguinal canal is opened and the cord mobilised at the internal ring. A double throw of a silicone vascular loop is placed around the cord to act as a vascular clamp. The scrotal tumour is then mobilised through the scrotal neck and delivered into the groin wound (Figs 13.8A to C). If tumour is confirmed, following high ligation of the cord at the internal ring, orchidectomy is performed. If the scrotal skin has followed the testicular mass upwards, careful dissection is undertaken to ensure that no tumour is left behind. Biopsy must be performed at this stage if it is feared that invasion of scrotal tissue has occurred. This is rarely required. Hemiscrotectomy may be necessary if the scrotal skin is involved. There is no case for retroperitoneal node sampling or dissection. Postoperatively, AFP should be measured regularly and the results charted. Particular note is taken of any histological evidence of tumour extension to the cut end of the cord or any breaching of the capsule of the tumour in the scrotum.

Stage I testicular germ cell tumours should carry a virtually 100% survival rate.

### Ovary

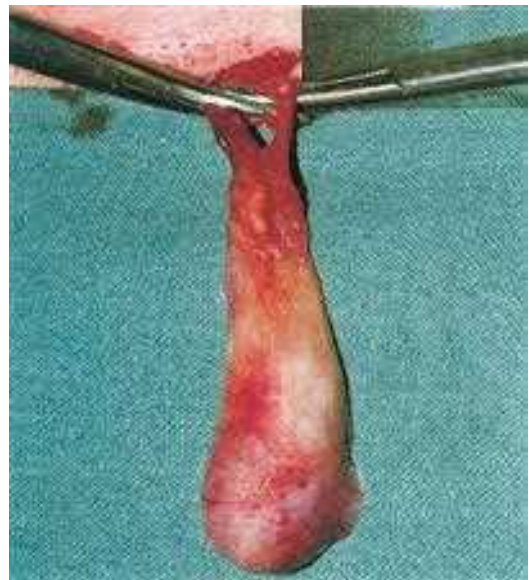
In contrast to testicular tumours, ovarian malignant germ cell tumours usually present after the first decade of life and with widespread pelvic or intra-abdominal tumour spread. In advanced cases, ascites and cachexia are found. In the majority of girls abdominal pain leads to the finding of a lower abdominal mass and its nature is established by the results of acquiring serum AFP or  $\beta$ -HCG levels (Figs 13.9A and B). Abdominal radiographs may show a mass teratoma containing bone or teeth and a mixed echogenicity appearance on ultrasound examination suggests the presence of solid and cystic components (Fig. 13.10). The presence of these findings while compatible with a benign teratoma, do not exclude malignant germ cell tumour. Clues to malignancy will come from CT or MRI evidence of invasion of pelvic wall tissues or other viscera, or evidence of obstruction of ureters. Chest radiograph and ultrasound examination of lymph nodes are called for in all suspected cases of malignant germ cell tumour.

If investigations suggest that surgical excision is possible, this should be undertaken. Rarely when a benign teratoma is being removed, evidence of peritoneal deposits of neuroglial tissue may be found and biopsy is required. The prognosis is good and chemotherapy not required. A needle biopsy serves to make a histological diagnosis. Laparoscopy may be a highly suitable instrument to control the acquisition of several samples of an invasive tumour.

Following chemotherapy and re-evaluation on scanning, an additional role for the surgeon may be at second-look laparotomy or laparoscopy to check for any residual malignancy and of course to excise any benign teratoma.



**Fig. 13.8A:** Clinical photograph of a testicular tumour (orchidoblastoma)



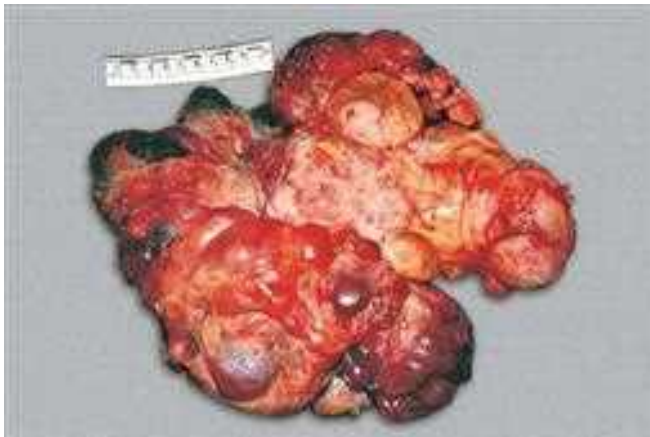
**Fig. 13.8B:** Operative photograph showing groin incision, cord clamping and removal of tumour



**Fig. 13.8C:** Orchidectomy specimen with cord clamped



**Fig. 13.9A:** Malignant ovarian tumour filling the abdomen



**Fig. 13.9B:** Tumour excised

### *Sacrococcygeal*

Teratomas in the newborn are most common in girls, are almost always benign and 40% of them are sacrococcygeal. Altman et al. noted and classified the varying anatomical presentation with type I virtually all external and without presacral extension, and type IV, entirely presacral and without external component. Type IV teratomas tended to present late and are more difficult to detect. Some teratomas, however, are now found on prenatal ultrasound studies sometimes causing obstructive uropathy. These tumours may be inherently more associated with malignant germ cell tumours, but in any case, a neglected tumour acquires a high-risk of malignancy after 6 months of age.

It is likely, therefore, that prompt and correct surgical management will prevent the occurrence of some malignancies. The teratoma should be excised with a margin of surrounding subcutaneous tissue. It must be detached carefully from pelvic floor muscles, and any intrapelvic

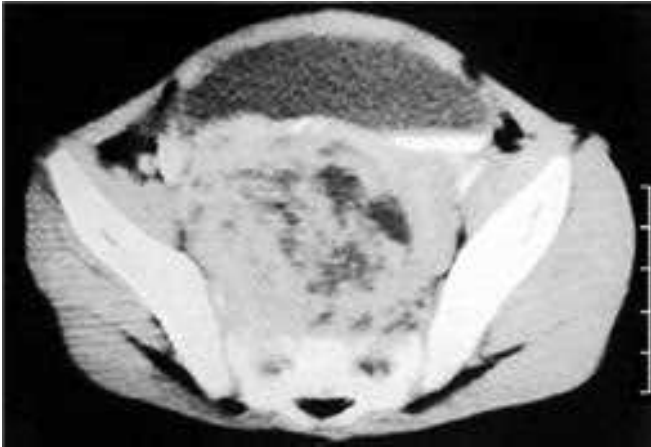


**Fig. 13.10:** Iliac crest bone in an ovarian tumour (desmoid)

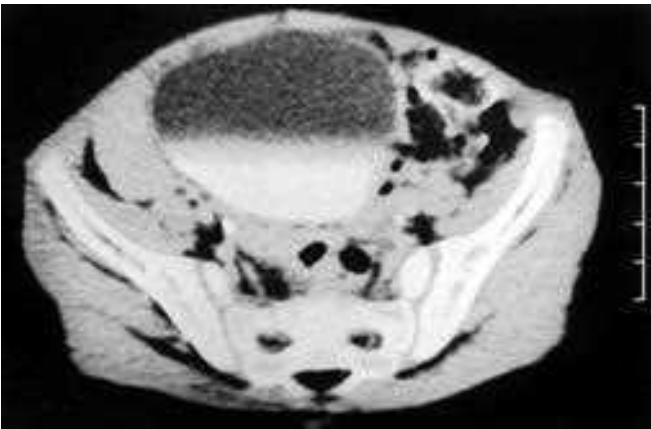
extension protruding through them requires very exact attention to surgical detail to minimise long-term sequelae in the urinary tract and rectum or anal canal. The pelvic floor muscles will need careful repair in relation to the repositioned anal canal (which in Altman types I and II is often found tilted to face forwards). Teratomas of types III and IV, mainly or entirely intrapelvic, require a combined abdominal and perineal approach. On occasions, these tumours may so fill the pelvis that risks of damage to the rectum during surgery are very high; and a colostomy may rarely be warranted until the integrity of the rectum has been checked by contrast imaging some weeks after the excision of the teratoma. Rarely a pubic symphysiotomy may afford some vital extra dissection space during removal of a difficult intrapelvic teratoma.

In all cases, the coccyx itself must be excised with the tumour to minimise the risk of either benign or malignant recurrence which can occur in 30% of cases in which the coccyx is left in place at the original procedure.

After excision of the teratoma, follow-up evaluation using serum AFP levels as a guide to an event-free postoperative status must take normal infant levels of AFP into account. Until 8 months of age, regular rectal examination is justified, after which serum AFP levels will yield accurate evidence, not only of pelvic, but of any possible metastatic yolk sac tumour. Malignant recurrence in the site of excision of a sacrococcygeal teratoma (or malignancy associated with a neglected tumour) is very unlikely to be surgically excised (Figs 13.11A and B). Symptoms usually include constipation or obstruction of the urinary tract or both. A primary pelvic tumour will need to be distinguished by scanning from some benign lesions, including anterior lipomeningocele, presacral



**Fig. 13.11A:** CT scan showing mixed density pelvic recurrence of a malignant yolk sac tumour in a patient aged 16 months



**Fig. 13.11B:** Pelvic CT scan after chemotherapy showing complete disappearance of the yolk sac tumour recurrence

neuroblastoma and pelvic RMS. The serum AFP will almost certainly confirm the diagnosis. In a primary tumour, biopsy is obligatory, but this may be omitted where a sacrococcygeal teratoma has previously been excised. After chemotherapy, surgical excision of any residual teratoma is required. Frequently no malignant tissue is found in the specimen after chemotherapy.

#### *Other Extracranial Sites*

Wherever benign teratomas are found, malignant germ cell tumours may occur in relation to them. Teratomas are found in association with almost all intraperitoneal organs and also occur in the retroperitoneum. The most common mode of presentation is with abdominal pain leading to the discovery of a mass, although a mass may have been noted on antenatal ultrasound. In any case, retroperitoneal lesions tend to present in very small children.

In contrast, mediastinal teratoma occurs in older children and adolescents. Mediastinal tumours are mainly

found in the anterior superior compartment apparently arising from the thymus. They may reach considerable size before compression of the major airways produces cough, wheezing and breathlessness. Hemoptysis has been reported and may be related to extension of teratoma into a bronchus. Occasionally these tumours may be hormonally active and induce precocious puberty. Plain radiographs of the chest may show features of teratoma (calcification) and CT scanning will elucidate the involvement of airways and other major structures. After obtaining serum AFP and  $\beta$ -HCG levels, biopsies should be planned. If the serum AFP level is normal, the lesion is probably benign and should be excised. In cases of malignancy chemotherapy is likely to be successful and primary surgery is only indicated if a very well defined tumour can be removed without damage to vital structures. 'Debulking' surgery is contraindicated. After chemotherapy, excision of any residual teratoma and tumour is planned using further scans and serum AFP levels as a guide to response.

Extracranial teratomas in the head and neck tend to occur in early life and often present in the newborn. Cervical teratoma is often detected on prenatal ultrasound examination. Delivery of these infants should be performed at a high-risk delivery centre with paediatric surgeons available at delivery, as prompt organisation of an adequate airway (including possible tracheostomy) may be life-saving. Excision of a benign teratoma in this region may be surgically demanding. A malignant yolk sac tumour occurring in the teratoma site is easily dealt with by chemotherapy. Most patients can be managed on the basis of serum AFP estimations without the need for repeated scanning.

#### *Intracranial Tumours*

Only 2–3% of intracranial tumours are of germ cell origin, but the majority of pineal tumours are of this group. Suprasellar tumours also occur, with girls more likely to be affected. The chief presenting symptom in suprasellar tumours is diabetes insipidus, and in pineal tumours, raised intracranial pressure. Abnormal eye movements, oculomotor palsies and visual field disturbances may be observed and hormonally active tumours may induce precocious puberty.

The discovery of a pineal tumour on CT or MRI scanning is highly indicative of a malignant germ cell tumour. MRI is most likely to detect a small suprasellar lesion, and often shows the characteristic mixed density of these tumours. CT scanning with contrast shows the bright enhancement corresponding to the increased vascularity that often accompanies these lesions.

The next move in investigation is to measure levels of tumour markers simultaneously in serum and CSF samples. In addition, the cytology of the CSF is important since



positive findings of malignant cells indicate CNS metastatic spread.

The largest current treatment study, successfully piloted for over 3 years, runs under the auspices of the SIOP (now the International Society of Paediatric Oncology). The protocols avoid surgery where possible, in marked contrast to the surgical emphasis in some North American centres.

Yolk sac tumours, embryonal carcinoma (including mixed tumours) and choriocarcinoma account for just over one-third of intracranial germ cell tumours. In the presence of characteristic scanning features and positive tumour markers, the tumour should not be biopsied, thus sparing the patient the risks of intruding into a highly vascular intracranial lesion. To date, though results in secreting CNS tumours are not good, biopsy confers no known added value to management. In the absence of cytological evidence of CNS spread, chemotherapy (described below) is instituted. Following regression, radiotherapy is given focally to the lesion, with a surrounding margin. With positive cytology, or if CNS metastases were found on scanning at presentation, complete craniospinal axis radiotherapy is required.

In a few cases, during chemotherapy, tumour markers may disappear without full regression of the tumour on imaging. This occurs most commonly in a mixed malignant tumour where  $\beta$ -HCG secreting choriocarcinoma disappears leaving embryonal elements of poor chemosensitivity. Alternatively, a benign teratoma may constitute the residue. Under these circumstances, surgical excision is essential.

Germinomas do not secrete markers, and biopsy is essential to differentiate them from other CNS tumours, including all the more common types. Mediastinal germ cell tumours in boys with  $\beta$ -HCG positive tumour markers have been reported in patients with Klinefelter's syndrome. Germinomas, like their gonadal counterparts, are highly radiosensitive, and survival of over 90% is achievable. The two possible approaches include craniospinal axis irradiation with a boost to the primary tumour site and chemotherapy with focal radiotherapy to the primary site. To date, no trial of these two methods has been evaluated. Since good results are obtained, very large numbers and wide international collaboration would be required to show a difference in survival or in morbidity. Most germinomas occur in teenagers, and radiotherapy does not result in the cognitive disorders seen, for instance, after treatment of CNS leukaemia in the young.

Where early and urgent surgical management of hydrocephalus with increased intracranial pressure has been required, the risks of tumour dissemination via the ventriculoperitoneal shunt must be borne in mind. Chemotherapy has shown as much success in treating systemic dissemination from ventriculoperitoneal shunting as in treating CNS metastases from extracranial tumours.

## Chemotherapy

Advances in chemotherapy have led to: (a) a clearer role for surgery and biopsy; (b) improved survival and (c) lower levels of toxicity and long-term sequelae. Thus, due to toxicity or late effects, some highly effective regimes are now reserved for relapsed or incompletely responding patients. For instance, the alkylating agent cyclophosphamide is avoided due to the effect on fertility, except with adriamycin<sup>®</sup> (doxorubicin), vincristine, actinomycin-D and cyclophosphamide (Adria-VAC) in relapsed patients. The lung toxicity observed with use of bleomycin has led to careful modification of the dose and method of administration of this highly effective agent. Finally, for extracranial tumours, carboplatin has been substituted for the more ototoxic and nephrotoxic cisplatin. The formula for the administration of carboplatin has been refined.

Results are now available from the UKCCSG's second germ cell tumour trial (GCII) showing that carboplatin, etoposide and bleomycin (JEB) are effective and less toxic than previous regimens in the treatment of extracranial non-gonadal malignant germ cell tumours. In this trial, which ran from 1989 to 1995, courses of JEB were given every 3 weeks until remission was achieved (assessed by normal serum AFP and/or  $\beta$ -HCG levels and radiological findings) followed by two further courses. In each course, etoposide 120 mg/m<sup>2</sup> was given intravenously over 1 hour on each of days 1–3, carboplatin 600 mg/m<sup>2</sup> intravenously over 1 hour on day 2 and bleomycin 15 mg/m<sup>2</sup> intravenously over 15 minutes on day 3.

Among the 44 survivors of chemotherapy in GCII, 43 are evaluable and none has renal impairment; four children have deafness. This contrasts with renal impairment in 6 of 30 evaluable children in the previous trial (CGI) and deafness in 11. In GCII, toxicity appears to be among the lowest yet, while still comparing favourably for survival with all previous trials worldwide (Fig. 13.12).

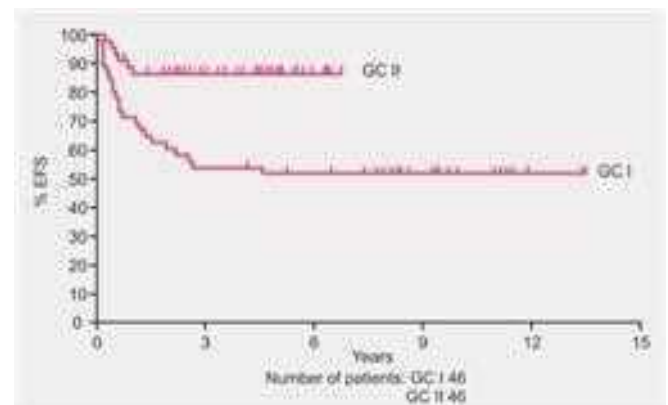


Fig. 13.12: Event-free survival for 46 cases treated in GCI (the six low dose VAC cases were excluded) and all 46 cases treated in GCII

For intracranial germ cell tumours, mostly those secreting tumour markers, the current SIOP study uses cisplatin, etoposide and ifosfamide (PEI), in 4 courses before further evaluation with a view to subsequent radiotherapy or surgery.

### Radiotherapy

The high chemosensitivity of most malignant germ cell tumours excludes radiotherapy from treatment programmes. Rarely a focal metastasis in a resistant tumour may be treated to relieve symptoms. The chief exception is germinoma. Few gonadal germinomas occur in childhood, but they are highly radiosensitive, and good results are obtained. Similarly, the intracranial germinoma has been successfully treated by radiotherapy for more than two decades. In adolescents, the dose required is unlikely to produce the cognitive effects seen in the irradiated brain of the young child. However, some suprasellar germ cell tumours present with an effect on the pituitary, and irradiation may extend the damage. Lack of growth hormone in adults may be harmful and lead to obesity and other symptoms, and endocrine surveillance is required after therapy in all such patients.

### Prognosis

The correct combination of surgery and chemotherapy has recently resulted in excellent outcomes, building on the fine

results for testicular tumours which have been achieved over the last decade. Many testicular tumours are cured by correct surgical management alone. Though up to 25% of these are either metastatic at presentation or relapse after appearing to be stage I, survival at or near 100% is reported. Two patients died out of 74 in UKCCSG GCI, after a low dose of VAC was given for metastases. All patients receiving full dose VAC survived. It is expected that patients in the later trial GCII will have at least as good results with fewer toxic effects.

Ovarian tumours prove more difficult to manage, and 25% relapse after initial chemotherapy or fail to respond to first line treatment. Of the extragonadal tumours, the rare primary sites including vagina, uterus and prostate carry the best prognosis. A quarter of malignant tumours recurring in the site of a sacrococcygeal teratoma may show relapsing or persistent disease, and mediastinal primary tumours carry a similar poor prognosis. However, a number of relapsing patients are salvaged by Adria-VAC or other more toxic chemotherapy regimes.

The advance in chemotherapy can be judged by the difference in 5-year event-free survival in GCI (46%) and GCII (87%).

---

### BIBLIOGRAPHY

1. Gupta DK, Carachi R (Eds). *Pediatric Oncology*, New Delhi: Jaypee Brothers Medical Publishers; 2007.

# Dermatology

# 14

## INTRODUCTION

The function of the skin is to provide a barrier between the outside world (i.e. the environment) and our internal organs. This barrier provides physical, mechanical, chemical and immunological protection from the external environment. It also has important sensory, endocrine and thermoregulatory functions.

The skin is a complex organ consisting of three layers: (1) epidermis, (2) dermis and (3) subcutaneous fat. Within the three layers there are many types of cells (Fig. 14.1).

The epidermis is the outside layer of skin that is a continually regenerating living barrier. More than 90% of its cells are keratinocytes. The keratinocytes mature and move up to form an outer layer of dead cells. These form a waterproof protective layer.

Melanocytes are found in the basal layer of the epidermis. These cells produce melanin, which absorbs and scatters

ultraviolet light, visible light and near infrared radiation. Thus providing a physical barrier and protecting against damage from sunlight. Melanosomes (packets of melanin) protect the nucleus from the harmful effects of ultraviolet radiation. Without this protection skin cancer may develop.

Diseases affecting the epidermis usually result in abnormal scale, change in pigmentation or loss of surface integrity resulting in an erosion or the production of an exudate.

The dermis contains collagen and elastic fibres which provide an elastic tough supportive layer under the epidermis. Specialised structures within this layer include hair follicles and sweat glands. It also contains mast cells, macrophages and lymphocytes.

The subcutaneous layer provides some added protection in the form of shock absorption.

It is also an energy store and helps to maintain body heat. This layer is made up of adipocytes that form lobules and are separated by fibrous septae. The blood supply is carried in this septae.

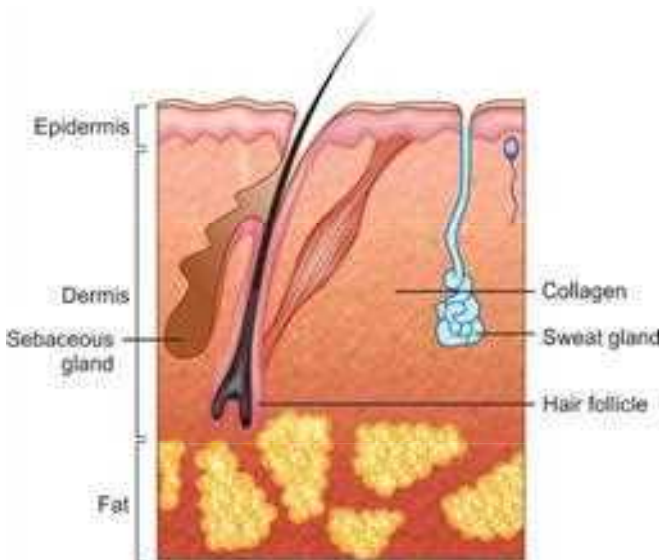


Fig. 14.1: Diagram of structure of normal skin

## COMMON TERMS USED

Erythema:	A patch of redness caused by capillary dilatation or hyperaemia
Macule:	A small circumscribed flat area of altered skin colour
Papule:	A small (< 5 mm) solid elevated skin lesion
Plaque:	A large (> 5 mm) solid elevated skin lesion
Nodule:	A circumscribed elevated solid skin lesion
Vesicle:	A small (< 5 mm) fluid-filled elevated skin lesion
Bulla:	A large (> 5 mm) fluid-filled elevated skin lesion
Pustule:	A small (< 5 mm) pus containing elevated skin lesion

Wheal:	A transient skin lesion consisting of an elevated pale centre with a surrounding flare of erythema. Often described by patients as 'blisters'. It is characteristic of urticaria and can be produced by the release of histamine in the dermis.
Scale:	A sheet of adherent corneocytes in the process of being shed
Crust:	Dried exudate consisting of a mixture of serum and scale, sometimes with erythrocytes and leucocytes
Ulcer:	A discontinuity in the skin surface involving the complete loss of epidermis
Erosion:	A superficial ulcer
Excoriation:	A scratch mark
Lichenification:	A patch or plaque in which the epidermis appears to be thickened and the normal skin creases are more prominent
Scar:	A patch or plaque in which the skin surface has lost the normal surface crease, contour and skin appendages.

## HISTORY

As in any other branch of medicine a careful history is important. The history, not only about the rash or lesion, but also about general health and relevant family history is fundamental to making a correct diagnosis. In children, obviously this information will be obtained from a parent or carer but it should be from the person who is most involved with the care of the child and who can give an accurate history.

### Important Questions about the Rash or Lesion

1. When and where and how did it begin?
2. Has it changed and if so how?
3. Does it come and go?
4. Does anything make it better or worse?
5. Is it itchy, painful or tender?
6. Does anyone else in the family have a similar rash or lesion?
7. How is their general health, are they otherwise well and thriving?

### The Examination

The close examination of the whole skin under good light is important. There are three aspects to the examination:

1. The distribution of the rash or lesion. Is it limited to one particular area or areas or widespread, in other words,

2. The morphology of the primary lesion. In other words what does a lesion look like when it first appears? What shape, colour and size is it? Is it scaly or smooth or does it form blisters?
3. The configuration of the rash. Are lesions separate or in groups? Is it discrete or confluent? Is it annular or linear?

## Diagnosis

The history and examination will often be enough to make a diagnosis. If there is still doubt then some further investigations may be required such as skin scrapings or hair sent to mycology, if fungal infection is suspected. Swabs to check if there is bacterial or viral infection. Blood tests may be required and occasionally a biopsy.

## VASCULAR ANOMALIES

Vascular birthmarks are classified according to that suggested by Mulliken and Glowacki in 1982. This classification was slightly modified and accepted in 1996 by the International Society for the Study of Vascular Anomalies. Essentially vascular birthmarks fall into one of two categories: vascular tumours or vascular malformations. Tumours are vascular lesions in which there is hyperplasia of the vessels while malformations are lesions in which there is dysplasia of the vessels.

### Vascular Tumours

The most common vascular tumour is the infantile haemangioma, sometimes known as a strawberry naevus or birthmark. About 10% of infants will be diagnosed with one. They are more common in girls and in premature infants. Chorionic villous sampling during pregnancy also increases the risk.

This benign proliferation of endothelial cells has a very distinctive history. The lesion is not usually present at birth; if present it is in the form of a faint bruise like mark. It normally becomes evident within the first few weeks of life and has a period of rapid growth. It can increase in size considerably and continue to grow for up to 12 months (Fig. 14.2). It is then followed by a period of slow involution over a number of years (Fig. 14.3).

Infantile haemangioma can be superficial where all the growth are above the skin or deep, where the growth is below the skin surface. Often there is a combination of superficial and deep (Fig. 14.4).

The appearance is often of a rapidly expanding bright red plaque, this is the superficial component. The deeper component can be more difficult to diagnose and usually takes longer to involute than the superficial one. This is a fast flow lesion and so is warmer than surrounding skin. If there is doubt about the diagnosis Doppler ultrasound can be



**Fig. 14.2:** Infantile haemangioma before signs of involution



**Fig. 14.3:** Infantile haemangioma showing the first signs of involution



**Fig. 14.4:** Infantile haemangioma of neck mainly deep type with small



**Fig. 14.5:** Infantile haemangioma on eyelid



**Fig. 14.6:** Infantile haemangioma on eyelid closing the eye and requiring treatment with oral steroids

Most haemangioma do not require any treatment. After the growing phase, they begin to pale or whiten on the surface and then slowly shrink down. A small number of the large ones do not completely involute and require some cosmetic tidying up in the form of laser treatment or surgery.

There can be significant and serious complications of some haemangioma and this largely depends on their site, these are listed below (Figs 14.5 and 14.6).

Site	Complication
Around the eye causing restricted vision	May result in permanent eye sight problems, e.g. amblyopia
Lip and perineum	Ulceration bleeding and infection
Beard area	Pressure on larynx and trachea
Nose	Cartilage damage
Ear canal	Hearing problems
Large facial ones	PHACE syndrome
Midline lumbosacral	Spinal dysraphism

Treatment if required is usually with corticosteroids, either topical, intralesional or systemic which will usually halt the growing phase. They have to be started early during the growing phase and will have to continue throughout until the growing phase has stopped which can be several months.

Embarking on a fairly long course of oral steroids has to be given careful consideration as to whether the benefits outweigh the risks. The dose has to be reasonably high between 2–4 mg/kg per day to be effective in halting the growing phase, and this will need to continue probably for several months. These children obviously need careful monitoring to check height and weight, urine for sugar and BP.

More recently treatment with oral propranolol has proved successful in reducing the size of the haemangioma. It is still in the early stages but a dose of between 1–2 mg/kg in

dermatologists are using. The side effects include transient diarrhoea, potential hypoglycaemia if child not eating regularly, and wheezing if child gets a chest infection. The treatment is still being evaluated but may prove very valuable in the future.

### PHACE Syndrome

This is a rare syndrome where there is an association of posterior fossa brain malformations, haemangiomas, arterial anomalies, coarctation of the aorta, cardiac defects and eye abnormalities. It is usually associated with large segmental facial haemangioma.

### Other Less Common Types of Haemangioma/ Vascular Tumour

Two other types of vascular tumours can sometimes be confused with infantile haemangiomas. These are: (1) the tufted angioma and (2) the Kaposiform haemangio-endothelioma. The history and behaviour of these two vascular tumours will give a clue to the diagnosis, but usually a biopsy is required to confirm the diagnosis.

They may look like infantile haemangiomas but do not give the classic history. They may or may not be present at birth.

The main concern with these two tumours is that they may be associated with Kassabach-Merritt phenomenon. Rapid swelling of the tumour occurs with bruising and purpura. There is a severe thrombocytopenia with platelet trapping and some consumption of fibrinogen and coagulation factors. This condition is always life-threatening and requires urgent treatment.

- *Congenital haemangioma*: These haemangioma look like infantile haemangioma but are present and fully formed at birth. They do not have a growing phase and either involute quite rapidly or do not change at all.
- *Diffuse neonatal haemangiomas*: Numerous small cutaneous and visceral haemangiomas. Hepatic lesions can lead to high output cardiac failure. Gastrointestinal ones can present with bleeding.
- *Multiple neonatal haemangiomas*: Multiple small cutaneous haemangiomas without visceral lesions.

## Vascular Malformations

Vascular malformations are composed of dysplastic vessels and can be made up of capillary, venous, arterial, arteriovenous, lymphatic or a combination of vessels.

### Capillary Malformation

The most common type of capillary malformation is the Salmon patch. This is a red patch, often in the shape of a



Fig. 14.7: Salmon patch on the nape of the neck



Fig. 14.8: Capillary malformation (Port-Wine stain) on the face

nose and upper lip. It can also form a patch at the nape of the neck (Fig. 14.7). These patches are present in about 50% of infants and usually disappear by the age of 2 years although the ones on the nape of the neck often persist. They are of no consequence.

The next most common type of capillary malformation is often referred to as a Port-Wine stain (Fig. 14.8). It is a flat red mark that can occur anywhere on the body and is present at birth. It can sometimes fade a little in the first year but then darkens again. Eventually, it becomes quite purple in colour. It does not resolve on its own but requires treatment with laser. These are slow flow lesions and so is the same temperature as surrounding skin.

If the capillary malformation is within the ophthalmic division of the trigeminal nerve segment on the face there is a risk of Sturge-Weber syndrome. This is a triad of—capillary malformation in ophthalmic division of the trigeminal nerve, eye and brain abnormalities.

Venous malformations are also slow flow vascular malformations so the skin temperature is normal. They often appear as bluish compressible birthmarks. They can be quite extensive and radiological imaging may be necessary to determine the extent. Craniofacial lesions can cause bony deformities resulting in functional impairment. Treatment is aimed at preventing this. Treatment is difficult but surgical excision and percutaneous sclerotherapy may be helpful.

Arteriovenous malformations are more serious lesions, which can worsen over time especially around the time of puberty or due to some kind of trauma to it either accidental or ill advised surgery.

They are fast flow lesions so warmer to the touch than surrounding skin. They can look like other vascular birthmarks. They are warm like haemangiomas but do not have the classic history of rapid growth and then slow

warm to touch unlike Port-Wine stains, which have normal skin temperature. If there is any doubt about the diagnosis Doppler ultrasound should confirm the diagnosis, and MRI scan will show the extent of the lesion.

## DISORDERS OF PIGMENTATION

Either too much pigment or too little can pose quite a distressing cosmetic problem. This is particularly so in darker skinned individuals as the pale or white patches stand out more.

### Postinflammatory Hypopigmentation and Hyperpigmentation

Any kind of inflammation in the skin can result in changes in the pigment, either hypopigmentation or hyper-pigmentation. Even when all the inflammation is settled the change in pigment remains for sometime before completely resolving (Fig. 14.9).

This is particularly seen in atopic eczema. In darker-skinned individuals the inflammation instead of appearing red as in white skin may only appear as darker areas of skin along with a palpable rash.



**Fig. 14.9:** Hypomelanosis—congenital hypopigmented area in groin area, upper thigh and lower trunk

### *Pityriasis Alba*

This is a form of postinflammatory hypopigmentation where pale patches appear mostly on the face (Fig. 14.10). These are more evident in the summer time when the sun has darkened the rest of the skin. They usually fade over the winter but may return again the following summer. Many parents and even doctors get very concerned about this because they confuse it with vitiligo. However, pityriasis alba, which



**Fig. 14.10:** Pityriasis alba

treatment, is a form of hypopigmentation while vitiligo is complete de-pigmentation. If the skin is dry an emollient can be prescribed and if any inflammation is evident, and mostly if it is not, a mild topical steroid can be used for a week or two.

### *Vitiligo*

This usually presents with symmetrical white patches that can occur anywhere. The white patches occur due to depigmentation caused by the destruction of melanocytes. This can be a major cosmetic problem depending on where the white patches are. It is obviously more noticeable on dark-skinned individuals. The areas of skin appear as chalk white but developing vitiligo in dark-skinned individuals may show various shades between normal skin and totally de-pigmented skin (Fig. 14.11).

About 25% of those with vitiligo develop it before the age of 10. The vitiligo is most commonly generalised but can be segmental. Patches of vitiligo can also affect the hair and mucous membranes.

Vitiligo is thought to be a type of autoimmune disease in which there is a complete loss of melanocytes. There is often a family history of vitiligo or of other autoimmune diseases. Children themselves with vitiligo rarely show signs of other autoimmune diseases and routine screening is not required.

Treatment with potent topical steroids may stimulate re-pigmentation. Parents, however, should be warned that the white patches, because there is no pigment, are more susceptible to sun damage and should, therefore, be protected with either clothing or sunscreen. More recently topical tacrolimus has also been found in some cases to be



**Fig. 14.11:** Vitiligo showing the symmetrical depigmented patches

### *Piebaldism*

This is another condition in which there are white patches due to lack of melanocytes in the skin. However, this is an inherited condition in which there is a defect in the proliferation and migration of melanocytes during embryogenesis. It can be differentiated from vitiligo by the fact that it is present at birth and is not progressive.

### *Hypomelanosis of Ito*

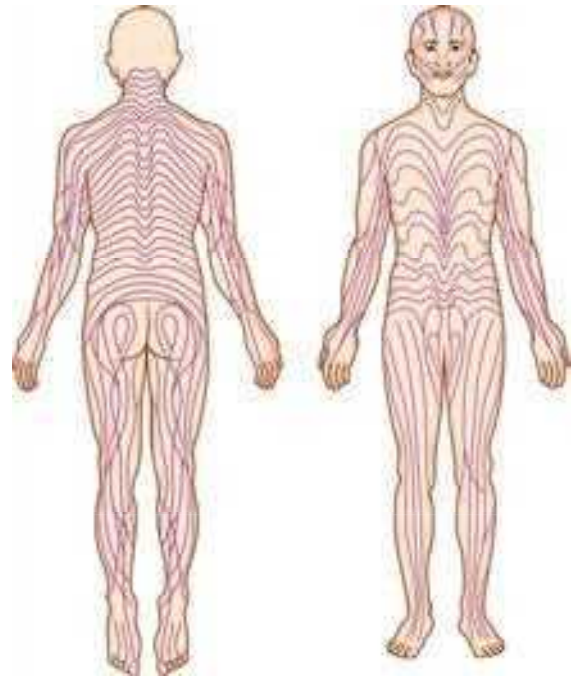
This condition is characterised by hypopigmented patches or streaks, which often follow the lines of blaschko (Fig. 14.12). They are usually present at birth, but may develop in the first 2 years of life. Thereafter, they usually remain stable. This is usually a benign condition but may be associated with other abnormalities.

### *Tuberous Sclerosis*

This inherited condition has manifestations in the skin, central nervous system, the eye and viscera. It may initially present with a number of hypopigmented macules usually called ash leaf macules. These macules can be a variety of shapes—oval, lance-shaped, ash leaf or small confetti like shapes.

Other cutaneous features include angiofibromas of the face, connective tissue naevi (forehead plaques and shagreen patches) and periungual fibromas (Fig. 14.13). Any child who presents with hypopigmented patches should be carefully followed up and monitored for other signs of tuberous sclerosis.

Other conditions, which may present with hypopigmentation, are pityriasis versicolor, lichen sclerosus and



**Fig. 14.12:** Blaschko lines—represent lines of embryological neuroectodermal migration



**Fig. 14.13:** Angiofibromas (adenoma sebaceum)

## CAFÉ AU LAIT MACULES

These are light brown, flat, round or oval lesions, which may have an irregular border. They can occur anywhere on the body. They may be present at birth or develop in the first few months. They can, however, increase in number and size throughout childhood.

When there are only a few lesions (less than 5) it is usually insignificant and not associated with any other abnormalities. However, they may be a marker for neurofibromatosis especially when there are more than 5.

Neurofibromatosis is an inherited condition with





**Fig. 14.14:** Neurofibromatosis showing café au lait macules



**Fig. 14.15:** Neurofibromatosis showing café au lait macules and axillary freckling



**Fig. 14.16:** Dermal melanocytosis—Mongolian blue spots

nervous system. There should be at least 5–6 café au lait macules greater than 5 mm present to warrant suspicion and other signs should be looked for such as axillary and inguinal freckling, lisch nodules in the eyes and a family history (Figs 14.14 and 14.15). These children should be followed up and carefully monitored for any changes in their skin. Regular checks on BP, height, weight and examination of the spine should be carried out. They should be referred to ophthalmology for regular eye examinations.

One very large café au lait macule, particularly if it has a jagged margin may be a marker for McCune-Albright syndrome. This syndrome is a triad of café au lait macules, polyostotic fibrous dysplasia and endocrine disorders.

## DERMAL MELANOCYTOSIS

- *Mongolian spots*: Approximately 80% of Asian and African-American babies are born with or develop in the first few months of life a Mongolian blue spot. This is a patch of blue-grey or darker pigmentation usually located over the sacrum and lower back (Fig. 14.16). It can, however, be more extensive and involve the trunk, buttocks and lower limbs. They are completely benign and the majority fade and clear before adulthood. If seen in combination with a capillary malformation (Port-Wine stain) it may be part of a syndrome called phakomatosis pigmentovascularis.
- *Naevus of Ota*: Blue-grey pigmentation in the periorbital region in ophthalmic and maxillary divisions of the trigeminal nerve distribution on the face is known as a naevus of Ota. It is common in Asian babies and also more common in girls.

It is usually present at birth but may not become



**Fig. 14.17:** Linear epidermal naevus—following the lines of Blaschko

- mistaken for bruising but its unchanging and lasting appearance differentiates the two. It is generally permanent and may in fact darken and increase in size. Referral for ophthalmologic review should be made to exclude glaucoma.
- *Naevus of Ito*: This is similar to the naevus of Ota but the blue-grey pigment colour is on the shoulder area, neck, upper arms and upper trunk area. It does not resolve but is generally a benign condition.

## EPIDERMAL NAEVI

### Epidermal Naevus

These lesions often present at birth or shortly after. They are usually initially light brown in colour and may be slightly raised or papillomatous. Later, they often become warty and are sometimes mistaken for viral warts. They are usually



Fig. 14.18: Sebaceous naevus on the scalp

### Sebaceous Naevus

This naevus is typically found on the scalp but may also be found on the face or neck (Fig. 14.18). It is present at birth but is not always recognised as at this stage it is often flat and the changes are subtle. Later, it is noticed as a round, oval or linear patch of alopecia. However, on close examination it will be noticed that the patch of skin on the scalp in a different colour from the rest of the scalp. It is usually a slightly pink, yellow or orange colour. It remains hairless and in adolescence becomes slightly raised and warty.

The sebaceous naevus is thought to be a variant of the epidermal naevus and is derived from the adnexial structures especially apocrine and sebaceous.

There is a very small risk of development of benign and malignant tumours but usually later in life. Therefore, treatment is usually excision in late childhood or adolescence.

## BLISTERING DISORDERS

### Epidermolysis Bullosa

Epidermolysis bullosa (EB) is a group of rare inherited diseases characterised by blistering due to friction or trauma to the skin. There are defects in the complex network of proteins in the layers of the skin, which in effect hold the skin together.

This means that even the slightest pressure on the skin can cause blister formation. The skin then lifts off leaving raw eroded areas, which are painful.

There are a number of subtypes, which are determined by the inheritance pattern and the level in the skin where the defect and therefore the split (blister) occur. A biopsy is needed to make the diagnosis. The subtypes range from severe with a poor prognosis to fairly mild. The main types are EB simplex, junctional EB and dystrophic EB.

There is no cure for this condition and the child is subject

exercised when handling these babies and children to prevent further blistering. The mucous membranes may be involved and when the gastrointestinal tract is affected problems with nutrition occur. The teeth and eyes may need special care and mobility is often a problem.

The main job of the dermatologist is to make the diagnosis and then coordinate care for these children. They will need special nursing care and may need referral to numerous other specialities.

### Staphylococcal Scalded Skin Syndrome

This condition is caused by *Staphylococcus aureus*, which produce an exotoxin resulting in an acute illness with blister formation. The initial symptom is often tender erythema of the skin, which is often worse in the flexural and periorificial areas. The mucous membranes are not generally involved. At this stage, the child may be generally unwell with fever, irritability, conjunctivitis or rhinitis. This is followed quickly by the development of large flaccid bullae (blisters), which are fragile with a thin roof comprised only of the upper layer of the epidermis. These quickly peel away to leave large moist glistening denuded areas, which are extremely painful. These bullae are in fact sterile (Fig. 14.19).

The source of the infection is not always clear but may be from the nasopharynx, the umbilicus in a neonate, urinary tract infection, conjunctiva or a cutaneous wound.

This condition usually affects young children. It is potentially life-threatening and prompt treatment with appropriate IV antibiotics is required. Semi-occlusive dressings with petrolatum will ease the pain and analgesics as required. Recovery is usually rapid and healing occurs without scarring.

The diagnosis is usually made based on the typical clinical picture, but if there is any doubt biopsy will confirm the split in the skin to be in the upper epidermis.



If this condition occurs in the neonate it may be confused with EB, and in the older child with toxic epidermal necrolysis (TEN). Biopsy will differentiate. In TEN, the split in the skin is lower and the mucous membranes are often involved. TEN is a more serious illness with a potentially poorer prognosis so making the correct diagnosis is important and starting the correct treatment is essential. Drug reactions are the most common cause of TEN and therefore the offending one need to be withdrawn. Supportive measures such as correcting any electrolyte and fluid imbalance as well as care for the skin, which may need to be done in a specialised burns unit, are needed.

### Fungal Infection

Fungal infection (dermatophytes) can affect any part of the body, affecting hair skin or nails, and are named after the part of the body affected.

Tinea capitis is fungal infection of the scalp. It can be quite discrete affecting only a small patch of scalp causing scaling and hair loss or it can be more widespread, with scaling, hair loss and sometimes pustules, affecting most of the scalp (Figs 14.20 and 14.21). Many types of fungi cause this and among them are *Trichophyton tonsurans*, *T. rubrum*, *T. soudanese*, *T. violaceum* and *Microsporum canis*.

A kerion may develop. This consists of pustules and painful tender nodules, which may coalesce and expand. There is marked inflammation with pain and tenderness and an underlying boggy of the scalp from which there may be oozing, crusting and hair loss. This is frequently misdiagnosed as a bacterial abscess. Treatment, however, is not surgery but antifungals such as griseofulvin or terbinafine. If not treated promptly hair loss may be permanent. A common source of infection is from cattle.



Fig. 14.20: Tinea capitis showing widespread involvement



Fig. 14.21: Tinea capitis showing small area of scaling and hair loss



Fig. 14.22



Fig. 14.23

Figs 14.22 and 14.23: Tinea corporis

Tinea corporis (fungal infection of the body) appears as round annular expanding lesions, which are slightly scaly especially at the edge. They may be slightly red and inflamed and have tiny pustules (Figs 14.22 to 14.24). These lesions are often mistaken for eczema and treated with topical steroids, which masks the appearance and is then called tinea incognito.

Tinea corporis can usually be treated successfully with topical antifungals, but if it is very widespread may need systemic treatment.

Tinea of the nails (tinea unguium) results in the nails becoming thickened, yellowish and crumbly. In adults and older children, treatment generally needs to be systemic and for a long course about 3–6 months or more. One would be reticent to embark on such a long course of systemic treatment in young children particularly if the tinea unguium is not bothering them. Topical treatment or just observation may be the most appropriate treatment for them. Fortunately



**Fig. 14.24:** Tinea cruris—fungal infection of groin area

Diagnosis of fungal infection is made by plucking hair samples, taking skin scrapings or nail cuttings for culture and examination. It is important to identify the source of the infection, which may be human, animal or soil. If it is from a family pet or other animal known to the family it needs to be examined and treated by a vet.

### Scabies

Human scabies is caused by *Sarcoptes scabiei ssp. hominis*. Infants even as young as 4–5 weeks old can be affected. Babies are unable to scratch so the symptoms are often irritability, poor sleeping and feeding. A generalised erythematous vesiculopapular rash is seen and the papules are commonly found on the palms and soles of babies (Fig. 14.25).

In older children, itch is the predominant feature especially at night. Scabies should be considered part of the differential diagnosis in any slightly atypical itchy rash especially if other family members are itchy. In children with eczema, it can be the cause of a sudden flare of their eczema. The presence of burrows confirms the diagnosis but is not always evident.

Treatment is usually with topical permethrin 5% cream and all family members and regular contacts should be treated at the same time.

### Impetigo

Impetigo is a superficial skin infection mostly caused by *S. aureus* but occasionally by *Streptococcus pyogenes*. Impetigo normally develops on skin which is already affected by a primary skin disease such as atopic eczema or an area of skin which has been traumatised by either an insect bite, laceration, burn or other condition resulting in a break in the normal skin barrier (Fig. 14.26). It tends to occur more



**Fig. 14.25:** Scabies—widespread pruritic papules seen over the trunk and axilla



**Fig. 14.26:** Impetigenised atopic eczema

Impetigo is generally recognised by its honey colour crusted plaques. It can be localised to a small area of skin or become more generalised especially when it is secondarily infecting previously diseased skin. Most children with impetigo remain well although they may have some localised adenopathy. In children with eczema, the infection may be quite subtle and appear only as a flare of the eczema with some yellow crusting.

If only a small area is affected a topical antibiotic such as mupirocin may be sufficient otherwise swabs should be done for sensitivities and the appropriate antibiotic started. Flucloxacillin is usually the antibiotic of choice.

### Atopic Eczema

This is one of the most frequently seen conditions in paediatric dermatology. It commonly presents after the first few weeks of life as a red rash on the face and scalp. It then becomes more widespread especially on the extensor aspects of the limbs but usually spares the nappy area. As the child becomes older the flexures of the limbs become the



**Fig. 14.27:** Excoriated eczema of face



**Fig. 14.29:** Flared eczema of knees showing lichenification and infection



**Fig. 14.28:** Flared eczema of the hands showing lichenification and an area of crusted infection



**Fig. 14.30:** Excoriated eczema of the arm

severe cases, it can be extensive and widespread (Figs 14.27 to 14.30).

Eczema is always itchy but it is not always apparent in neonates, young infants or children with any degree of physical weakness. It may manifest itself in these children as irritability and poor sleeping.

This is a chronic relapsing condition and is associated with a family history of atopy (atopic eczema, asthma, hay fever or allergic rhinitis). It is distressing to the child because of the constant itch but also to the whole family who become very stressed because of an irritable child who sleeps poorly. Parents are particularly distressed because of lack of sleep and a feeling of failure because they do not seem able to comfort or help their child.

There is no cure for eczema but the majority of children can have their symptoms controlled and most of them grow out of it before adulthood.

The principal features of eczema are dry skin, red itchy inflammation and frequent bouts of secondary infection. Treatment is, therefore, aimed at controlling these symptoms.

The skin is very sensitive and many things such as woollen

dust mite will all cause a flare of the eczema. Excessive heat and sweating may also irritate the skin. Avoidance of such irritants is therefore important.

Moisturisers should be applied to the skin frequently and regularly to prevent the skin drying out. These also, especially the greasier ones, form a barrier on the skin to help prevent irritants and infection getting in. Moisturisers should continue to be applied even when the skin is not red and itchy. Bath oil and a moisturising soap substitute should also be used. Once, it is under control many children can keep their eczema settled with moisturisers alone and very occasional topical steroid.

The itch and inflammation of eczema is best controlled with topical steroids. Weak steroids are used for the face, folds and napkin area. Stronger steroids may be required intermittently for severe flares but should only be given under close supervision. Moderate to potent steroids are usually required for intermittent use on the limbs and trunk.

Topical tacrolimus is proving a useful alternative to topical steroids particularly on the face. This is especially so around the eyes where strong steroids are usually contraindicated.

well-established yet, so a degree of caution should be used and sun protection is advised when using it.

Infection with *S. aureus* is a problem for many individuals with eczema and it is often the cause of a sudden severe flare, which does not respond to their normal treatment. Swabs for culture and then appropriate oral antibiotics may be necessary. Regular use of a soap substitute, which has an antiseptic as one of its ingredients, can be helpful in reducing infection.

Treatment for atopic eczema is quite complex with different creams and ointments to be used at different times. It can be quite confusing for parents; therefore, time spent writing out a treatment plan and then going over it with the parents is very worthwhile. Follow-up care to ensure that treatment is being applied properly and appropriately and the skin is settling and coming under control is important.

Restriction of diet is usually unnecessary and should only be done when there is clear evidence of a reaction to a particular food. It should then be done under the supervision of a paediatric dietician.

Fortunately most children respond to these measures but for the ones with more severe eczema wet wrap bandaging for limited periods may be helpful. Children who are still unresponsive and whose eczema is making them miserable may require systemic treatment such as azathioprine.

### Eczema Herpeticum

Children with atopic eczema do not handle the herpes simplex virus normally and when infected with it the infection can become widespread and the child systemically unwell. Admission to hospital is often necessary for IV acyclovir. The infection is recognised by numerous small discrete erosions. Swabs should be taken for confirmation of the diagnosis. If possible children with eczema should avoid contact with people who have cold sores (herpes simplex). In particular, family members with a cold sore should not kiss children especially those with eczema. The herpes simplex virus cannot be eradicated and the child will suffer recurring episodes of localised cold sores or even widespread eczema herpeticum.

### Seborrhoeic Eczema

This is a condition generally affecting children in the first year of life. Characteristically there is a greasy, yellowish, thick scale on the scalp, usually known as cradle cap (Fig. 14.31). When more extensive the face, especially the eyebrows, nasolabial folds and malar eminences, the ears and the chest can also be affected with erythema and yellow greasy scale (Fig. 14.32). Unlike atopic eczema where the napkin area is spared in seborrhoeic eczema the napkin



Fig. 14.31: Seborrhoea of the scalp—cradle cap



Fig. 14.32: Seborrhoeic dermatitis showing yellow scaling of eyebrows, forehead and scalp



Fig. 14.33: Seborrhoeic dermatitis showing involvement of the folds in napkin area

area is often affected especially the folds (Fig. 14.33). The axillary area can also be similarly affected.

This condition is often confused with atopic eczema, but the classic clinical picture and distribution of the rash along with the fact that the rash is not itchy and therefore the child

is usually happy and content differentiates the two. In young babies, there can be an overlap, and they can in fact have both atopic and seborrhoeic eczema.

*Candida albicans* often invades the affected areas and therefore treatment, which is with a mild to moderate steroid, may be combined with an anticandidal preparation.

### Napkin Dermatitis

The most common type of napkin rash is irritant contact dermatitis due to the contact of urine and faeces with the skin. The rash is initially red and scaly but quickly becomes deeply erythematous with a typical glistening or glazed appearance (Fig. 14.34). It typically spares the folds of the napkin area. It is very painful and the child is miserable especially at each nappy change. If left untreated punched out ulcers and erosions develop.

Nappies should be changed as soon as they are soiled and a thick emollient such as zinc and castor oil cream or



Fig. 14.34: Napkin dermatitis

petrolatum jelly should be used to act as a barrier to urine and faeces.

When napkin dermatitis occurs a mild potency steroid may be applied 2–3 times a day and thick emollients should be applied at each nappy change. If candida or bacterial infection is also suspected an antibiotic or anti-candidal agent should be added.

### Psoriasis

Psoriasis is uncommon in children under 10 years, but when it does occur it can have a similar distribution to seborrhoeic eczema affecting mainly the scalp, ears and napkin area especially in young children. In fact, in some children only the napkin area is involved and the diagnosis is difficult and may be confused with irritant napkin dermatitis or seborrhoeic eczema.

In older children, it can have the same distribution as in adults, i.e. the scalp, ears, elbows, knees and periumbilical area (Figs 14.35 to 14.37). Occasionally only the scalp is



Fig. 14.35: Psoriasis—plaque located over the pressure point of the knee



Fig. 14.36: Psoriasis—typical plaques with silvery scales



Fig. 14.37: Psoriasis

affected. It may or may not be itchy and there is often a family history of the condition.

Psoriasis occurs as large well-demarcated scaly plaques with a red or pink base or as guttate lesions, which consist of numerous small round red scaly lesions usually beginning on the trunk but becoming more widespread. Nail changes including nail pitting, onycholysis and subungual hyperkeratosis may be present.

Children are more prone to guttate psoriasis, which often occurs after a throat infection. This type may clear completely and stay clear but normally psoriasis is a chronic relapsing condition.

Treatment is with emollients and mild steroids for face, nappy area and folds and tar preparations for elsewhere. Dithranol and calcipotriol can be used in slightly older children.

### Melanocytic Naevi

These are localised proliferations of melanocytes and they are often classified according to where the naevus cells lie in the dermis or epidermis and whether or not they are present at birth or acquired throughout childhood.

Acquired naevi are generally small brown lesions less than 5 mm in size and evenly pigmented with a regular shape and border. Malignant melanomas are rare before puberty but may be suspected, if the edge becomes irregular, the colour becomes uneven or there is rapid growth. Children with a family history of malignant melanoma are at slightly increased risk.

Congenital melanocytic naevus (CMN) is present at birth or within the first few months of life. They are usually categorised by their size. Small are 1–1.5 cm, intermediate are 1.5–20 cm and greater than that are called large or giant. The margin of these congenital naevi is often irregular as is the colour and surface (Figs 14.38 and 14.39). They are often hairy and grow in size in proportion to the child's growth.

Small CMNs occur in 0.01 of the population, intermediate CMNs occur in 0.1 of the population and large or giant CMNs occur in 0.001% of the population (Fig. 14.40). Small and intermediate CMN do not seem to be at increased risk of developing malignant melanoma, but if so the risk is quite small. However, those with the large or giant type have an increased risk of between 6 and 8%.

However, in children with darker skins these lesions are less common as is malignant change.

Naevus spilus or speckled lentiginous naevus occurs as a light tan patch, which gradually develops small dark spots within it (Fig. 14.41).



Fig. 14.38: Congenital melanocytic naevus



Fig. 14.39: Melanocytic naevus



Fig. 14.40: Giant congenital hairy-pigmented naevus





Fig. 14.41: Naevus spilus (speckled lentiginous naevus)



Fig. 14.43: Granuloma annulare



Fig. 14.42: Halo naevus



Fig. 14.44: Pyoderma gangrenosum

### Halo Naevus

Occasionally, a white patch occurs around a pigmented naevus (Fig. 14.42). This reaction is mostly seen in children and is benign. Sometimes the naevus in the centre also depigments. This reaction is thought to be an immunological one and the patient may also have vitiligo or a family history of it.

### Granuloma Annulare

The cause of these lesions is unknown but they occur in children and adults. They are mostly to be found over bony prominences on the back of the hands or dorsum of the feet but they can occur anywhere. They begin as an expanding ring of pink papules. As it expands the central area clears leaving a roughly annular-shaped lesion with a beaded edge (Fig. 14.43). It is entirely asymptomatic but in adults can be associated with diabetes. These lesions are sometimes

diagnosed as fungal infection, but the differentiating feature is that granuloma annulare is not scaly.

These lesions can also appear as more flat purplish lesions and can be found as single or multiple lesions. They spontaneously involute and require no treatment. Intralesional steroid can sometimes hasten the resolution process but is very painful.

### Pyoderma Gangrenosum

Pyoderma gangrenosum is an uncommon condition in children but can occur in association with ulcerative colitis or Crohn's disease. It starts off as a small nodule or pustule, which quickly expands to form an ulcer. The edge has a characteristic undermined bluish appearance (Fig. 14.44). As well as treating the underlying disease topical and/or oral steroids are the treatment of choice although recently topical tacrolimus has been found helpful.



Fig. 14.45: Widespread urticaria

## Urticaria

This is a common condition at any stage in life although rarely seen before the age of 6 months. It starts acutely with transient red raised blotches, which expand and move around with each individual lesion clearing completely within 24 hours leaving normal skin behind. The appearance of the lesions can be quite dramatic, sometimes forming giant urticarial plaques with irregular borders, which move about in a bizarre fashion (Fig. 14.45). These giant lesions do not signify a more serious form of the disease. Often as they clear, they do so from the centre leaving rings which can mimic erythema multiforme. The lesions are described as very itchy but excoriations are rarely seen. The patient or parent often describes them as blisters due to the wheal like appearance of them. It is, therefore, important to ask if fluid comes out of them to which the answer is no.

In fact, most often when the patient arrives at the clinic the skin is completely normal indicating the transient nature of the condition. It is, therefore, important to try to get an accurate description of the lesion. Episodes may occur daily to begin with but generally as the condition improves episodes become less frequent.

The acute form lasts for up to 6 weeks but it may go on to become chronic and last several months or even years.

In children, this condition is often triggered by a viral infection although often no cause is found and investigations are unhelpful and unnecessary. However, a careful history should be taken of events leading up to the onset of the rash to exclude drugs or foods.

Angio-oedema may or may not accompany an episode of urticaria. Angio-oedema can be quite frightening for the individual and their family as they associate it with

and sometimes the hands and feet. However, it is usually mild and transient and there are no breathing difficulties or hypotension.

Treatment is with nonsedating antihistamines, which should be given on a regular basis until the episode is over.

Angio-oedema of a more serious nature does occur with anaphylaxis and hereditary angio-oedema. Anaphylaxis is a medical emergency as along with the urticaria and angio-oedema there is dyspnoea and hypotension. However, for the majority who have urticaria, this does not happen and the prognosis is good. If laryngeal oedema has not occurred during the first few hours it is unlikely to occur thereafter.

Hereditary angio-oedema is due to either deficiency of or loss of function of C1-esterase inhibitor. The diagnosis is made on the basis of the symptoms of abdominal pain, vomiting and massive oedema and a family history but is confirmed by doing a functional assay of C1-esterase inhibitor.

## Erythema Multiforme

Erythema multiforme develops as a reaction most often to an infection like herpes simplex or a drug. It is an acute self-limiting condition with typical target lesions mainly affecting the peripheral limbs. It can also affect the mucous membranes when it can be much more serious requiring hospital admission. However, it is usually a mild condition lasting several days or 1–2 weeks. Treatment is of the underlying infection or cessation of the offending drug.

## Erythema Nodosum

This condition presents as tender, red nodules often on the shins of the legs but can occur anywhere (Fig. 14.46). It is due to inflammation of the subcutaneous fat.



It is a reactive process usually caused by infections such as streptococcus, tuberculosis, brucellosis and leprosy. Drugs such as sulphonamides and oral contraceptive can also be responsible in older children. Erythema nodosum can also be associated with sarcoidosis, ulcerative colitis, Crohn's disease and Behcet's disease.

### Viral Warts

Warts are a common occurrence in children. They are caused by the human papilloma virus of which there are several types. They most commonly appear on the hands and feet but can occur anywhere on the body surface. They initially appear as smooth skin coloured papules but slowly enlarge and develop an irregular hyperkeratotic surface. They may appear as a slender stalk in which case they are called filiform warts and are commonly found on the face especially the nostrils of the nose and the lips. Viral warts usually spontaneously resolve once the immune system recognises and overcomes the virus but it may take many months.

If treatment is desired wart paints containing salicylic acid are usually effective. Cryotherapy with liquid nitrogen is also usually effective but is painful and not advised in young children.

Genital warts are less common and when they occur, especially in the older child, may be caused by sexual abuse. However, they can be caused by autoinoculation from warts elsewhere on the same individual or from a carer who has hand warts. In the young child (under age 4), they may also be caused by vertical spread from the mother *in utero* or during delivery. The virus may lie dormant and not manifest itself for some months or even years. It is often best to leave these warts to spontaneously resolve, as treatment with cryotherapy is inevitably painful.

### Molluscum Contagiosum

This is a viral infection, which produces crops of pearly dome-shaped papules with an umbilicated centre (Fig. 14.47). The condition is self-limiting and clears once the individual has developed his or her own immunity but it can take several months. This is mainly an infection affecting children and is quickly spread by contact with infected individuals often through shared baths, towels or swimming pools. The lesions are asymptomatic until they are beginning to clear when they develop an area of erythema around them, which is itchy. At this stage, children often scratch them and they can be susceptible to secondary infection. An antiseptic paint should be applied to prevent this.

Treatment is usually not necessary. Cryotherapy is effective but painful and not advised in young children.



Fig. 14.47: Molluscum contagiosum—umbilicated papules

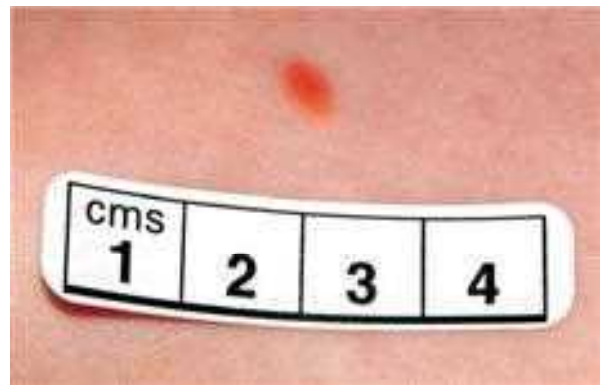


Fig. 14.48: Juvenile xanthogranuloma

### Juvenile Xanthogranulomas

These lesions have a very characteristic yellow/orange colour. They can occur as single or multiple lesions and are usually restricted to the skin but can occur in other organs. They usually present as nodules in the skin but can occur as plaques (Figs 14.48 and 14.49).

They are usually benign and self-limiting affecting infants and young children. Lesions may be present at birth but most occur in the first year of life. Rarely there can be an association with neurofibromatosis, juvenile myeloid leukaemia or urticaria pigmentosa, particularly when multiple lesions are present.

### Dermoid Cysts

These present as asymptomatic skin-coloured or slightly bluish nodules and occur anywhere on the face, scalp or spinal axis. Although these are congenital lesions, caused by



**Fig. 14.49:** Juvenile xanthogranuloma—plaque type



**Fig. 14.51:** Keloid scar—an abnormal reparative reaction to skin injury. Keloids are characterised by proliferation of fibroblasts and collagen



**Fig. 14.50:** Dermoid cyst at the lateral eyebrow area



**Fig. 14.52:** Mastocytoma—these lesions urticate if rubbed

faulty development of the embryonic fusion lines, they are not always noticed until early childhood when they begin to enlarge.

Midline or nasal dermoid cysts can have an intracranial connection and have the potential to become infected resulting in meningitis. These cysts should be surgically excised after radiological imaging.

A common site for them is the lateral eyebrow area and these lesions do not have a central nervous system connection and are, therefore, of less concern (Fig. 14.50).

### Keloid Scars

Keloid scars are caused by an exaggerated response to skin injury. Darker-skinned individuals seem to be more at risk of these and there is sometimes a familial tendency.

The scarring grows out beyond the original site of injury (Fig. 14.51). The chest and shoulder area seem to be most vulnerable to this type of scarring, but the face scalp and back of neck can also be quite badly affected often as a result

Treatment with intralesional steroid can sometimes flatten the scar and silicone gel can be applied topically but it is not always successful.

### Mastocytosis

Brown, reddish brown or yellow brown lesions can present either as individual lesions (mastocytomas) or as multiple lesions (urticaria pigmentosa) (Fig. 14.52). These lesions usually present during the first 2 years of life but can be congenital. In the early stages, they urticate and blister with any kind of friction. These lesions are full of mast cells, which release histamine to produce the typical wheal and flare reaction or blister.

The prognosis is generally good. The blistering usually stops by about the age of 2 and the lesions themselves often eventually spontaneously clear. Affected children should avoid histamine-releasing agents such as aspirin, opiates and cholinergic medications.

A small number of children, especially those with

as flushing, headache, diarrhoea and tachycardia. An anti-histamine with or without the addition of H<sub>2</sub> blockers can help. Cromolyn sodium is usually effective for patients with gastrointestinal symptoms.

### Ichthyosis

This is a group, if inherited disorders where the process of keratinisation is abnormal resulting in marked scaling and dryness of the skin, which ranges from mild to severe and incapacitating.

The most common type is ichthyosis vulgaris, which may appear no more than a very dry skin. A light-coloured fine scale, which is most obvious on the limbs and tends to spare the flexures, is evident. It is inherited as autosomal dominant.

X-linked recessive ichthyosis affects boys and is much rarer than ichthyosis vulgaris affecting 1:2,000. It can initially present as a collodion baby at birth with a shiny adherent film encasing the whole body. This shiny film is shed in the first few days leaving behind either normal skin, X-linked or more frequently lamellar ichthyosis (Figs 14.53 and 14.54).

X-linked ichthyosis is due to deficiency of the enzyme steroid sulphatase, the activity of which can be measured in the blood to give the diagnosis. It is characterised by large brown scales especially seen on the legs and trunk, and affects the flexures. There is a small risk of affected boys having hypogonadism and undescended testes.

The treatment for all the ichthyoses is emollients, which will not cure the condition but can make the individual more comfortable. For more severely affected individuals topical or systemic retinoids may help.



Fig. 14.54: X-linked ichthyosis with large dark scales



Fig. 14.55: Acrodermatitis enteropathica—buttocks

### Acrodermatitis Enteropathica

There are some other conditions, which may present like atopic eczema, whose diagnosis, it is important not to miss. Children with atopic eczema are otherwise well so when a child with eczema like rash has other symptoms such as failure to thrive, diarrhoea, an odd distribution of rash or a purpuric element to it, it is important to consider some other less common diagnoses.

Acrodermatitis enteropathica is an autosomal recessive disorder, which causes zinc malabsorption and deficiency. Zinc deficiency can of course also result from poor intake of zinc.

Babies affected by this have a typical eruption affecting mainly the cheeks and chin, the hands and feet, and the nappy area (Fig. 14.55). They usually have diarrhoea, failure to thrive and irritability. Measuring the zinc, plasma level points to the right diagnosis.

These children respond quickly to oral zinc sulphate but treatment may have to be long term.

## Wiskott-Aldrich Syndrome

Wiskott-Aldrich syndrome is another condition, which can present like atopic eczema but again the rash is atypical. There is usually a haemorrhagic component with purpura and patchier, and the child is unwell with bloody diarrhoea, frequent infections and failure to thrive. Many of the immunodeficiency disorders can also present with an eczematous rash but again there are other features, which should lead to the correct diagnosis.

## Herpes Simplex Infections

Cutaneous infections with herpes simplex virus are not uncommon in children. Primary herpes gingivostomatitis is the most common clinically apparent herpes infection. It is characterised by fever, malaise, headache and small eroded vesicles on the lips and oral mucosa (Fig. 14.56). Herpetic infections of the fingers and thumb may occur during the course of herpetic gingivostomatitis if children put them in their mouths. Herpetic genital infections are much less common in children than they are in adults. Sexual abuse should be considered a possibility in children with herpes genitalis.

No effective therapy is available for herpetic gingivostomatitis, although oral acyclovir can be used. In



**Fig. 14.56:** Herpes simplex infection of the mouth

children with gingivostomatitis healing usually occurs in 7–10 days.

## BIBLIOGRAPHY

1. Eichenfield LF, Freiden IJ, Esterly NB. Textbook of Neonatal Dermatology. Philadelphia: WB Saunders Company; 2001.
2. Schachner LA, Hansen RC. Pediatric Dermatology, 3rd edn. Mosby; 2003.

# Haematological Disorders

## HAEMATOPOIESIS

Within a few days of embryonic implantation "blood islands" develop in the human yolk sac. Cells from these islands develop into vascular endothelium and primitive blood cells. These pluripotent stem cells known as progenitor or CFU-GEMM (colony forming unit, granulocyte—erythroid/megakaryocyte—macrophage) cells produce red cells, white cells except lymphocytes and platelets (Fig. 15.1). Most

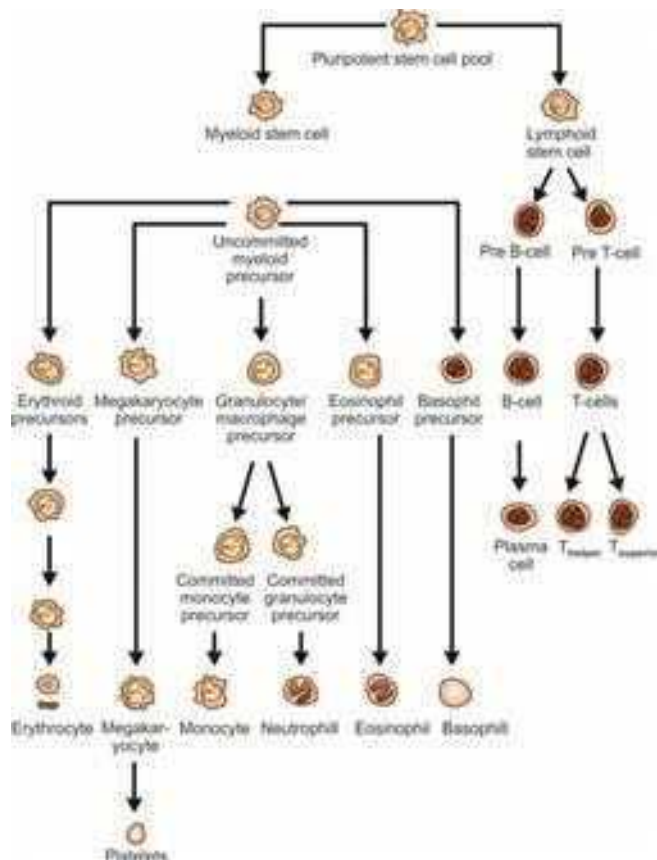


Fig. 15.1: Haematopoiesis in the embryo and foetus

haematopoiesis in the foetus takes place from progenitor cells seeded to the liver. Bone marrow haematopoiesis is present from about 10 weeks' gestation and by term has taken over almost all of the foetal haemopoietic function. Control of erythropoiesis in the foetus is through hepatic erythropoietin mediated by foetal tissue oxygen concentration. There is a switch to renal erythropoietin a few weeks after birth.

All of the white cell series and platelets are identifiable in foetal blood by about 14 weeks' gestation and the granulocyte series is controlled by the hormone GSF and platelets by thrombopoietin.

Modern haematology embraces many complicated techniques which have added greatly to our understanding of the nature of some of the less common disorders, e.g. haemolytic anaemias, haemoglobinopathies, megaloblastic anaemias, etc. None the less, the blood disorders commonly encountered in paediatric practice can most often be dealt with by use of relatively simple standard techniques.

## THE NORMAL BLOOD PICTURE IN INFANCY

Considerable variations in normal values during the early days of life have been recorded by different workers. There are several reasons for this. Blood samples obtained by venipuncture in early infancy have lower values for haemoglobin and red cell counts than those obtained by heel prick and individual infants show a wide variation in values. In routine clinical practice only fairly large departures from normal ranges are likely to prove significant.

## Haemoglobin

The haemoglobin (Hb) concentration in blood from the umbilical cord is high with a mean of 17 g/dl (17 g/100 ml). Values up to 20 g/dl may be recorded. A venous sample of the infant's blood some hours after birth may reveal an even higher Hb level with a mean of 19 g/dl, and a skin-prick sample is likely to be still higher with a mean of 21 g/dl. This rise in Hb values just after birth is probably due to

haemoconcentration due to diminution in the plasma volume, in addition to the infusion of red cells which may occur when late clamping of the umbilical cord is practised.

The oxygen-carrying capacity of the blood is related to the total circulating red cell mass (RCM) which can vary in normal infants between 30 ml/kg and 50 ml/kg depending on whether the cord is clamped early or late. Haemoglobin concentration and haematocrit can correlate poorly with the RCM especially in preterm infants. The RCM can vary between 12 ml/kg and 24 ml/kg in infants with a haematocrit of 0.3 (30%) due to compensatory reductions of plasma volume.

The Hb value falls to 10–11 g/dl by the age of 8–12 weeks but rises again to between 11 g/dl and 13 g/dl between the ages of 6 months and a year. Thereafter, the Hb level increases to 11.5–15 g/dl by the age of 10–12 years and reaches normal adult values (men = 13.5–18 g/dl; women = 11.5–16.5 g/dl) by the age of 15 years. The explanation for the fall in Hb level during the early weeks of life is that, although erythropoiesis continues at a high level found in the foetus for about 3 days after birth, an abrupt decline in erythropoiesis then occurs and the marrow erythroid count falls from 40,000–6,000/mm<sup>3</sup>. This is reflected in a fall in the reticulocyte count from 3% or 4% just after birth to under 1% 1 week later.

At birth 50–65% of the Hb is of the foetal type (Hb-F) which resists denaturation with alkalis. It has a slightly different electrophoretic mobility and a quite different oxygen dissociation curve from adult type haemoglobin (Hb-A). After birth Hb-F is slowly replaced by Hb-A so that after a year of age only small amounts of Hb-F are still present. In certain diseases, such as thalassaemia and sickle-cell anaemia, Hb-F is produced in excessive quantity. The value to the foetus of Hb-F appears to be that of a greater affinity for oxygen at low tensions than Hb-A and an ability to release CO<sub>2</sub> more readily.

Since the discovery in 1949 of the first abnormal haemoglobin molecule (Hb-S) a great deal of information has accumulated about the molecular structure of haemoglobin. Over 100 variant forms of human haemoglobin have now been recognised. Some of these are associated with serious disease in various parts of the world.

## Red Cells

The red cell count at birth varies between 5.5 million/mm<sup>3</sup> and 7.5 million/mm<sup>3</sup>. The count falls to about 5–5.5 millions after 2 weeks and thereafter runs parallel to the Hb level. Scanty eosinophilic normoblasts are found in the peripheral blood at birth. Erythrocytes at birth have a larger diameter (about 8.4 μm) than in the adult. The mean adult value of 7.2 μm is reached after 1 year.

## White Cells

The total white cell count at birth is about 18,000/mm<sup>3</sup>. The adult value of 6,000–7,000/mm<sup>3</sup> is not reached for 7–10 years. At birth about 60% of the white cells are polymorphonuclear (11,000/mm<sup>3</sup>) and 30% are lymphocytes (5,400/mm<sup>3</sup>). During the ensuing 2 weeks the polymorphonuclear count falls to within the normal adult range (3,500–4,500/mm<sup>3</sup>) where they remain during the rest of childhood. On the other hand, the lymphocytes, predominantly of the large type in infancy, rise rapidly to about 9,500/mm<sup>3</sup> at 2 weeks and only slowly fall during the next 12 years to the adult level of about 1,500–2,000/mm<sup>3</sup>. It is important to remember the comparatively high lymphocyte count in normal children if mistaken diagnoses such as glandular fever or leukaemia are to be avoided. The monocyte ratio in children tends to be somewhat higher than in adults. Eosinophils and basophils show no special characteristics.

The normal blood volume in infancy is 85 ml/kg.

### Key Learning Point

#### Normal values

- It is essential to remember age-related haematology reference ranges for diagnostic purposes.

## IRON DEFICIENCY OR NUTRITIONAL ANAEMIA OF INFANCY

This is the only deficiency disease seen commonly among infants and children in the UK at the present time. The highest incidence of anaemia is found in the lower socio-economic groups.

### Aetiology

Several factors, singly or in combination, can result in this deficiency state. Breast milk and cow's milk are low in iron. Therefore unduly prolonged milk feeding (human or cow's) or feeding whole cow's milk in early infancy results in iron deficiency. This is perhaps the most commonly found factor. Another important factor is the influence of birth weight. It is well-known that preterm infants and others of low birth weight (such as twins or triplets) are particularly likely to develop iron-deficiency anaemia. Infants, whatever their maturity, have a body iron content of about 75 mg/kg fat free body weight. The bulk of the infant's iron endowment (66–75%) is represented by haemoglobin iron. One gram of haemoglobin contains 3.4 mg of iron. Complications of pregnancy or the perinatal period that result in blood loss will compromise the infants' iron endowment. The smaller infant grows more rapidly in proportion to his birth weight than the larger with a corresponding need for a larger increase in his



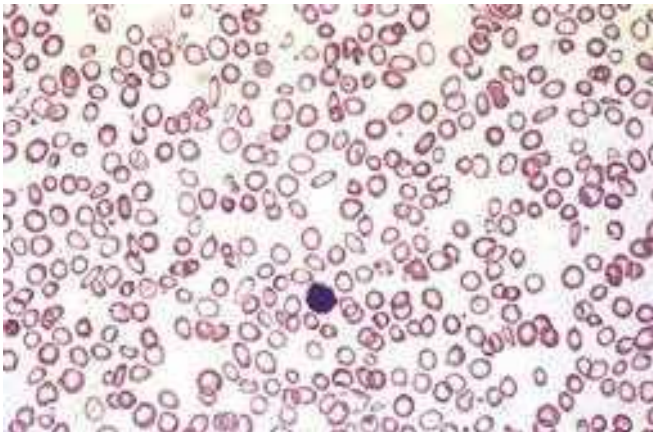
red cells and haemoglobin. As the amount of iron absorbed is very low during the first 4 months of life the small infant more rapidly exhausts his storage iron (in liver and spleen) and develops overt signs of iron deficiency. Unless extreme, the presence of maternal iron deficiency does not appear to compromise the iron endowment of the foetus. Infections, to which the iron deficient infant is prone, further aggravate the anaemia. Finally, the possibility of chronic blood loss from, e.g. oesophagitis, a Meckel's diverticulum or hook worm infestation or of iron malabsorption must always be considered in cases of iron deficiency anaemia. Occult GI bleeding can occur in infants who have been started on whole cow's milk early in life. Convenience foods are often low in iron. Red meat, eggs and green vegetables are sources of iron.

#### Key Learning Points

- ➔ Nutritional iron deficiency anaemia is seen commonly among infants and children during their first year.
- ➔ Breast milk and cow's milk are low in iron.
- ➔ Also convenience foods are often low in iron.

### Clinical Features

A mild degree of nutritional anaemia probably affects over 25% of infants during their first year. The onset is rarely before the fifth month of life. When the anaemia is severe there is obvious pallor of skin and mucous membranes. Splenomegaly may be present and there may be cardiomegaly and a haemic systolic murmur. The anaemia is microcytic and hypochromic (Fig. 15.2). Serum iron is markedly reduced (normal mean = 18  $\mu\text{mol/l}$ ; 100 mg/100 ml) and the saturation of the iron binding protein of the serum is reduced from 33–10% or less. The serum ferritin



**Fig. 15.2:** Peripheral blood smear of a child with iron deficiency anaemia. Lymphocyte represents a normal size red cell, hence microcytic hypochromic red cells with some red cells

concentration is reduced (less than 10 mg/ml). Bone marrow shows normoblastic hyperplasia and an absence of stainable iron. Ferritin is an acute phase protein and it is increased in inflammatory disease. Thus serum ferritin could be normal even in the absence of iron stores.

#### Key Learning Point

- ➔ Ferritin is an acute phase protein and it is increased in inflammatory disease. Thus serum ferritin could be normal even in the absence of iron stores.

### Prevention

In the term infant, iron deficiency is best prevented by the avoidance of whole cow's milk as a drink until 12 months and by the introduction of mixed feeding with foods rich in iron at the age of 4 months. In the pre-term infant iron should be given orally from the age of 4 weeks. The term infant should receive 1 mg of iron/kg per day and the pre-term infant 3 mg/kg per day.

### Treatment

In most cases the anaemia can be rapidly corrected with oral iron unless there are good reasons for using another route. Among the ferrous salts, such as sulphate, fumarate, succinate, glutamate, gluconate and lactate, the sulphate salt is considered to be the salt of choice. Ferrous salts show only marginal differences between one another in efficiency of absorption of iron. Ferric salts are much less well-absorbed. The oral dose of iron in an average child is 3–6 mg of elemental iron/kg (maximum 200 mg) daily administered 2–3 times daily between meals. The therapeutic response to iron therapy may be verified by any one of the following methods. A reticulocytosis may be noted 2–3 days after the start of therapy with a peak rise at 7–10 days. The haemoglobin concentration should rise by about 1–2 g/l per day or 2 g/100 ml over 3–4 weeks. Once normal haematological values have been attained iron should be continued for an additional 3 months to reconstitute depleted iron stores. Epithelial tissue changes such as atrophic glossitis and koilonychia are usually improved, but the response is often slow. The most common reason for lack of response in children is poor compliance; poor absorption is rare in children. Parenteral administration of iron as iron dextran or iron sucrose is indicated only if it is not possible to achieve compliance with use of oral iron or under the unusual circumstances in which iron malabsorption occurs. GI irritation can occur with iron salts. Iron preparations given orally can be constipating. However, if side-effects occur, the dose may be reduced; alternatively, another iron salt may be used. Neonatal anaemia resulting from repeated blood sampling does not

respond to iron therapy. Iron supplementation may also be indicated to produce an adequate response to erythropoietins in iron deficient children with chronic renal failure or in preterm neonates.

### Key Learning Points

#### Treatment of iron deficiency anaemia

- ➔ Treatment with an iron preparation is indicated only in the presence of a clearly demonstrable iron-deficiency state
- ➔ It is suggested that the possibility of thalassaemia should always be considered in children of Mediterranean or Indian subcontinent origin, prior to commencing an iron supplement.

### Case Study

A 2-year-old Asian girl presented with poor appetite and pallor. Mother's main concern was that her daughter looked pale as compared to her siblings. There was no history of bleeding from any orifice of her body. On examination, she was anaemic and had haemic murmur. Otherwise there was no positive finding. Haemoglobin was 6 g/dl.

Blood film: Hypochromic, microcytic red cells and no target cells were seen. Serum ferritin less than 5 µg/ml. Stools negative for intestinal parasites

*Diagnosis:* Nutritional iron deficiency anaemia..

### Key Learning Point

- ➔ Iron supplements are properly absorbed when taken on an empty stomach, however, they should be taken after food to minimize GI side-effects; they may also discolour stools.

## THE MEGALOBLASTIC ANAEMIAS (FOLATE DEFICIENCY, VITAMIN B<sub>12</sub> DEFICIENCY)

### Folate Deficiency

True megaloblastic erythropoiesis is rare in paediatric practise. Folate is absorbed unchanged in the duodenum and jejunum. It is provided by most foods including meat and vegetables. The most common cause is malabsorption of folic acid in the older child with inadequately treated coeliac disease. However, folate deficiency may also be caused by inadequate intake, increased requirements (haemolytic anaemia), disorders of folate metabolism (congenital and acquired) drugs and increased excretion in children on special diets. The long-term use of anti-convulsants (especially phenytoin) has been associated with megaloblastic anaemia, probably as a result of inhibition of conversion of dietary folate to absorbable monoglutamates. The symptoms of folate

deficiency anaemia are similar to vitamin B<sub>12</sub> deficiency except that neuropathy is not a feature of folate deficiency. Also the peripheral blood and bone marrow changes in folate deficiency are identical to those found in vitamin B<sub>12</sub> deficiency (Box 15.1).

Hypersegmentation of the neutrophils in the peripheral blood is the single most useful laboratory aid to early diagnosis (Fig. 15.3). The red cell or serum folate assay is a sensitive, reliable guide to the presence of folate deficiency and remains the best way of confirming early folate deficiency. Successful treatment of patients with folate deficiency involves correction of the folate deficiency as well as amelioration of the underlying disorder and improvement of the diet to increase folate intake. It is usual to treat folate deficient patients with 1–5 mg folic acid orally daily. Folinic acid is also effective in the treatment of folate-deficient megaloblastic anaemia, but it is normally only used in association with cytotoxic drugs.

### Key Learning Points

- ➔ Megaloblastic anaemia is rare in children
- ➔ There is no justification for prescribing multiple-ingredient vitamin preparations containing vitamin B<sub>12</sub> or folic acid
- ➔ Folic acid should never be given alone for vitamin B<sub>12</sub> deficiency states (because it may precipitate subacute combined degeneration of the spinal cord).

### Box 15.1: Prevention of neural tube defects

- Folic acid supplements taken before and during pregnancy can reduce the occurrence of neural tube defects.
- Couples who are at a high risk of conceiving a child with neural tube defects are:
  - If either partner has a neural tube defect
  - If either partner has a family history of neural tube defects
  - If previous pregnancy affected by a neural tube defect
  - If mother taking antiepileptic drugs

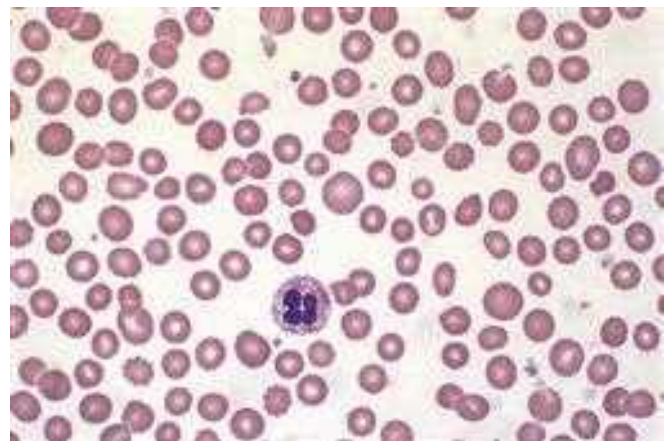


Fig. 15.3: Megaloblastic blood picture with oval macrocytic red cells

**Case Study**

An Asian 6-year-old girl had been on phenytoin for 2 years for recurrent seizures. Her seizures were reasonably under control. Over a period of 8 weeks, she developed pallor, weight loss and became anorexic. On her clinical examination spleen was enlarged 4 cm below the left costal margin. She had no jaundice or oedema. Haemoglobin was 4 g/dl, WBCs 1,500/mm<sup>3</sup> with 700 neutrophils/mm<sup>3</sup> and platelets were within the normal range. Blood film showed marked hypersegmentation of the polymorphs and some late megaloblasts. Reticulocytes were 3%. Serum folate was less than 2 ng/ml and B<sub>12</sub> 400 pg/ml. She was treated with folic acid 5 mg three times daily orally. A rapid reticulocyte response occurred (12%) and haemoglobin rose to 10 g/dl, 3 weeks from the start of folic acid therapy.

*Diagnosis:* Phenytoin associated megaloblastic anaemia due to folate deficiency.

**Vitamin B<sub>12</sub> Deficiency**

Vitamin B<sub>12</sub> deficiency in children is exceedingly rare. If it occurs it is caused either by a specific malabsorption of vitamin B<sub>12</sub> or as part of a generalised malabsorption syndrome. Vitamin B<sub>12</sub> is provided by foods of animal origin, fish, meat, eggs and milk. After resection of the terminal ileum there is a risk of a megaloblastic anaemia developing 2–3 years later once the liver stores are depleted. Those most vulnerable are children who lose terminal ileum as a result of tumour (lymphoma), necrotising enterocolitis (NEC), Crohn's disease or trauma. Most cases of vitamin B<sub>12</sub> deficiency occur during the first 2 years of life and others manifest later in childhood until puberty.

The clinical signs and symptoms of vitamin B<sub>12</sub> deficiency are related primarily to the anaemia but can also be complicated by subacute combined degeneration of the spinal cord. Glossitis with papillary atrophy may also be seen.

The haematological findings are indistinguishable from those of folic acid deficiency. The peripheral blood and bone marrow findings can be identical, but the serum vitamin B<sub>12</sub> level is low. A Schilling test may be necessary to diagnose vitamin B<sub>12</sub> malabsorption.

Most patients with vitamin B<sub>12</sub> deficiency require treatment throughout life. Vitamin B<sub>12</sub> therapy results in reticulocytosis that peaks in 6–8 days and falls gradually to normal by 12th day. Bone marrow returns completely from megaloblastic to normoblastic in 72 hours. Hydroxycobalamin has completely replaced cyanocobalamin as the form of vitamin B<sub>12</sub> of choice for treatment; it is retained in the body longer than cyanocobalamin and thus for maintenance therapy can be given at intervals of up to 3 months.

**THE HAEMOLYTIC ANAEMIAS**

The causes of haemolytic anaemia, which may be defined as one in which the life span of the red cells is shortened. The red cell life span in children is 120 days, 60–80 days in neonates and even shorter in premature babies. The classification of haemolytic disorders is as shown in Table 15.1.

**Table 15.1:** Classification of haemolytic disorders

**(i) Inherited Haemolytic Disorders**

- (a) Defects in the structure of the red cell membrane
  - Hereditary spherocytosis
  - Hereditary elliptocytosis
- (b) Quantitative haemoglobin disorder
  - Thalassaemias
- (c) Qualitative haemoglobin disorder
  - Sickle cell disease
- (d) Defects of red blood cell metabolism
  - G-6-PD deficiency
  - Pyruvate kinase deficiency
  - Other enzyme disorders

**(ii) Acquired Haemolytic Disorders**

- Immune
  - Autoimmune haemolytic anaemia
  - Alloimmune haemolytic disease of the newborn

**Hereditary Spherocytosis (Congenital Haemolytic Jaundice)****Aetiology**

Hereditary spherocytosis is one of the most common inherited haemolytic anaemias encountered in paediatrics. This disease is inherited in an autosomal dominant fashion but in 25% of the cases neither parent appears to be affected. This is most likely the result of spontaneous mutation. At present it seems likely that the physiologically important abnormality is an inherent instability of the red cell membrane. It is certain that the major part of the haemolysis of the abnormal red cells takes place in the spleen.

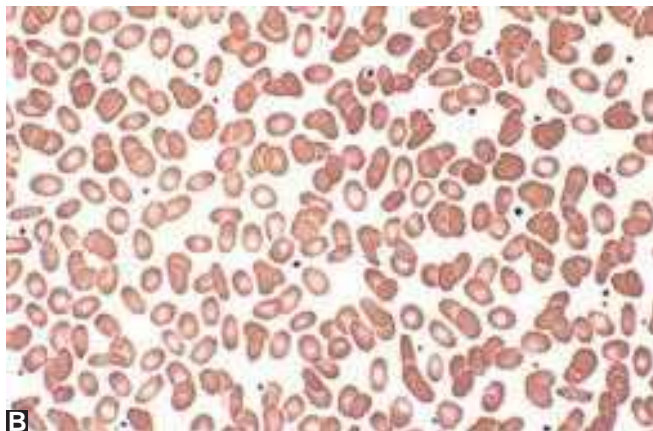
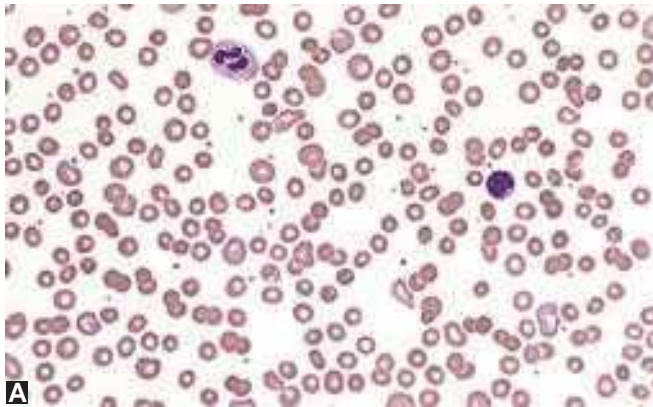
**Key Learning Point**

- Hereditary spherocytosis is one of the most common inherited haemolytic anaemias encountered in paediatrics.

**Clinical Features**

The disease is quite variable in its severity. However, most affected children will, at sometimes, manifest one or more of the cardinal features of the disease: anaemia; jaundice (unconjugated bilirubin) and splenomegaly. It can cause haemolytic icterus in the neonatal period and kernicterus has been described. It is, however, rare for the disease to appear in infancy. More commonly it presents during

later childhood with pallor and lassitude; less often with jaundice and highly coloured urine. Children may present with an acute abdomen from splenic infarcts. It may remain symptomless until adult life when biliary colic due to gallstones is not uncommon. Acute haemolytic crisis with severe anaemia and icterus require emergency treatment but they are, in fact, uncommon. Splenomegaly is usually present whatever the degree of haemolysis in hereditary spherocytosis. The red cells are unable to sustain a normal biconcave shape because of their metabolic defect. They are spheroidal with a smaller diameter than normal. It is usually easy to differentiate microspherocytes in well-stained blood films (Figs 15.4A and B). They appear unduly dark in colour and small in diameter than normal biconcave erythrocytes. A significant reticulocytosis is usually found. High figures may be reached during a crisis but the absence of a reticulocytosis does not exclude the diagnosis. Increased osmotic fragility of the red cells is an important diagnostic feature. The test is much more reliable when performed on a quantitative basis but is not pathognomonic of hereditary spherocytosis, being sometimes abnormal in acquired haemolytic anaemia, and infrequently it may be normal in the neonatal period. In



**Figs 15.4A and B:** (A) Peripheral blood film of hereditary spherocytosis showing microspherocytes and polychromasia. (B) Blood film of a child with elliptocytosis

hereditary spherocytosis Coombs' test is negative. Routine ultrasound of the gallbladder should be done to determine whether biliary pigment stones have developed. These should be removed at the time of splenectomy.

#### Case Study

A 4-year-old Caucasian boy presented with pallor and lassitude. On examination, he was anaemic and had slight scleral icterus. He had no lymphadenopathy or hepatomegaly but had 7 cm splenomegaly. His mother had splenectomy at 8 years of age. Haemoglobin was 6.2 g/dL, WBC  $6.6 \times 10^9/L$ , platelet count  $300 \times 10^9/L$ , reticulocyte count  $40 \times 10^9/L$ . Blood film revealed numerous microspherocytes. Total bilirubin was elevated at 160  $\mu g/L$  with an unconjugated bilirubin of 150  $\mu g/L$ . Aspartate aminotransferase (AST)/alanine aminotransferase (ALT) was normal. Ultrasound examination of gallbladder was negative for gallstones.

*Diagnosis:* Hereditary spherocytosis.

#### Treatment

Treatment usually consists of folic acid supplementation and splenectomy.

Splenectomy results in a return to normal health although it does not alter the metabolic defect in the red cells. It should always be advised in the child with hereditary spherocytosis since even mild disease interferes with growth and well-being. Splenectomy renders the child more susceptible to severe bacterial infections and there is good evidence that the risk is greatest in infancy. This can be reduced by immunisation with polyvalent polysaccharide pneumococcal vaccine. The vaccine should be given at least 2 weeks before splenectomy. At present re-immunisation is recommended every 5 years. Also *Haemophilus influenzae* type B and *Neisseria meningitidis* (meningococcus) may cause infection. In addition the child should receive life-long oral prophylactic phenoxymethyl penicillin and for those allergic to penicillin erythromycin should be used. If the child has not been previously immunised against *H. influenzae* it would be worthwhile giving HIB vaccine. For elective splenectomy, HIB vaccine should ideally be given at least 2 weeks before surgery. Meningococcal group C conjugate vaccine is recommended for children with asplenia or splenic dysfunction. Also children who had splenectomy are at particular risk of severe malaria. If they travel to malarious areas, rigorous precautions are required against contracting the disease. In our opinion splenectomy should be postponed until the child is about 5 years old. Children should carry a card with information about their lack of spleen. They should be educated on the potential risk of infection. There is no evidence that further delay is useful, and it may be harmful, since the risk of cholelithiasis increases in children after the age of 10 years. Control of the anaemia can meantime be

achieved by blood transfusion. Rarely, in the neonatal period a rising serum bilirubin level may necessitate an exchange transfusion to eliminate the risk of kernicterus. Box 15.2 shows the indications for splenectomy in children.

**Box 15.2:** Indications for splenectomy

- *Medical*
  - Hereditary spherocytosis
  - Hereditary elliptocytosis
  - Severe pyruvate kinase deficiency
  - Autoimmune haemolytic anaemia—warm IgG antibody type
  - Chronic immune thrombocytopenic purpura
  - Hypersplenism—who develop significant anaemia or thrombocytopenia
  - Sickle cell anaemia—acute splenic sequestration crisis
  - Thalassaemia major—increasing transfusion requirements caused by hypersplenism
- *Surgical*
  - Splenic trauma, splenic cysts, tumours and Gaucher's disease
  - Thalassaemia major—massive splenomegaly—for relief from mechanical stress

**The Thalassaemias**

The thalassaemia syndromes are characterised by deficiencies in the rate of production of specific globin chains. A microcytic hypochromic anaemia results.

*Developmental Changes in Haemoglobin Synthesis*

Normal adult and foetal haemoglobin contains four globin chains (Table 15.2). The thalassaemia syndromes are a heterogeneous group of disorders of haemoglobin (Hb) synthesis resulting from a genetically determined reduced rate of production of one or more of the four globin chains of haemoglobin— $\alpha$  (alpha),  $\beta$  (beta),  $\delta$  (delta) and  $\gamma$  (gamma). This results in an excess of the partner chains which continue to be synthesised at a normal rate. The alpha chain types are carried on chromosome 16 and the beta, delta and gamma on chromosome 11. Each type of thalassaemia can exist in a heterozygous or a homozygous state. The most common is beta thalassaemia (Cooley's anaemia) which involves suppression of beta-chain formation. In homozygotes, there is a severe anaemia with a high level of Hb-F (alpha 2, gamma 2), some Hb-A2 (alpha 2, delta 2) and a complete absence of, or greatly reduced (normal) Hb-A (alpha 2, beta 2). Heterozygotes on the other hand suffer from only mild anaemia with reasonable levels of Hb-A, somewhat raised Hb-A2, but Hb-F levels rarely in excess of 3%. Children of the mating of two such heterozygotes have a 1 in 4 chance of suffering from the homozygous state for beta thalassaemia. They will not present clinically, however, until later infancy when the effects of beta-chain suppression develop because Hb-A formation fails to take over from the production of Hb-F in the normal way. The other main type of thalassaemia

**Table 15.2:** Globin chains of normal haemoglobins

Adult	-	Hb A	$\alpha_2 + \beta_2$
	-	Hb A <sub>2</sub>	$\alpha_2 + \delta_2$
Foetal	-	Hb F	$\alpha_2 + \gamma_2$
	-	H Bart's	$\gamma_4$
	-	Hb H	$\beta_4$

involves suppression of alpha-chain production and as alpha-chains are shared by Hb-A, Hb-A2 and Hb-F it is to be expected that alpha thalassaemia would become clinically manifest in foetal life.

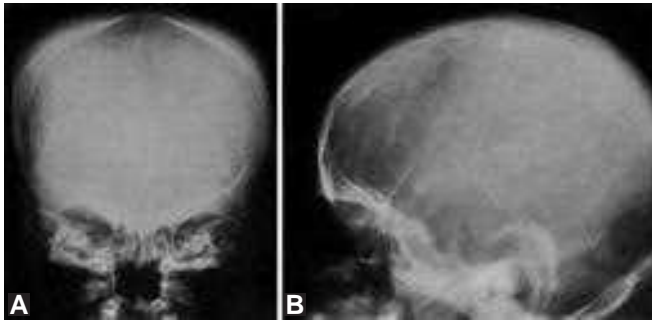
Tetramers of gamma chains may be produced (Hb-Bart's) which result in a clinical picture very similar to that in hydrops foetalis with massive hepatosplenomegaly and generalised oedema, with stillbirth or early neonatal death. In haemoglobin, H disease, on the other hand, tetramers of gamma chains (Hb-H) are present in excess and there is considerable clinical variability: From a picture indistinguishable from Cooley's anaemia to an absence of specific signs. Heterozygotes for alpha thalassaemia cannot be detected with certainty. The thalassaemias are uncommon in persons of British stock but they are commonly seen in children of Mediterranean, Middle Eastern, Indian, Pakistani origin as well as in South-East Asia where they constitute a major and distressing public-health problem. The distribution parallels with that of falciparum malaria for which the trait appears to have a selective advantage. The clinical account which follows refers only to the most common variety of beta thalassaemia in the homozygous state (beta thalassaemia major—Cooley's anaemia).

**Key Learning Point**

- ➔ The clinical severity of beta thalassaemia ranges from thalassaemia minor (usually symptomless), thalassaemia intermedia (with anaemia plus splenomegaly but not transfusion dependent) to thalassaemia major (transfusion dependent).

*Clinical Features*

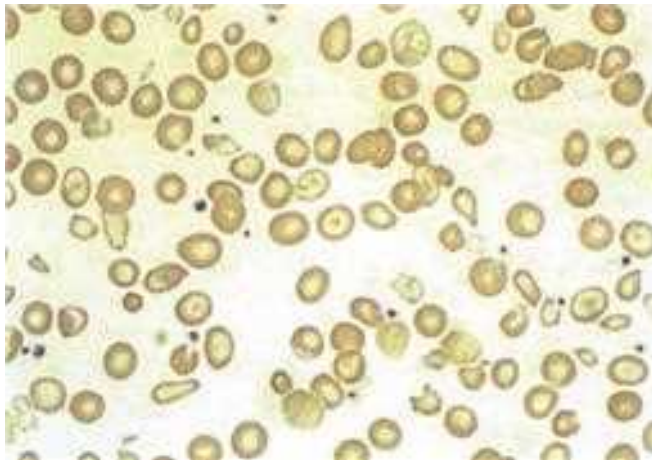
This condition is characterised by a chronic haemolytic anaemia which becomes manifest later in infancy, but not in the newborn. Pallor is constant and icterus not uncommon. Splenomegaly increases throughout childhood. Hepatomegaly is also present, largely due to extramedullary erythropoiesis. Pathognomonic skeletal changes can be demonstrated radiographically. Membranous bones of the skull are thickened and lateral views of the skull show the "hair on end" appearance (Figs 15.5A and B). The facies has a Mongoloid appearance due to thickening of the facial bones. The hands may become broadened and thickened due



**Figs 15.5A and B:** (A) Lateral view of the skull showing expansion of the diploic space and (B) a hair on end appearance of the skull vault



**Fig. 15.6:** AP view of the hand showing mild generalised osteopaenia, coarsening of the trabecular pattern, medullary widening and cortical thinning



**Fig. 15.7:** Peripheral blood smear of a child with homozygous beta-thalassaemia showing a target cell

to changes in the metacarpals and phalanges. These bone changes are due to the hyperplasia of the bone marrow (Fig. 15.6). Blood examination shows severe hypochromic anaemia with marked anisocytosis and poikilocytosis. Many microcytic red cells lie side-by-side with large (12–18 mm), bizarre-shaped cells. In some of the latter cells and abnormal central mass of haemoglobin gives to them the appearance of "target cells" (Fig. 15.7). Reticulocytosis is marked and Howell-Jolly bodies may be numerous. Serum unconjugated

bilirubin concentration is increased. There is increased serum iron while the iron-binding capacity is fully saturated and lower than in normal children. The haemoglobin pattern in beta thalassaemia major consists mainly of Hb-F, which may amount to 90% of the total and of Hb-A<sub>2</sub>; Hb-A is totally absent or greatly reduced. Most children affected by beta thalassaemia major can be kept in reasonable health, if they are maintained on a high blood transfusion regimen which prevents the Hb level from falling 11 g/dl. Other laboratory abnormalities commonly found in homozygous beta thalassaemia are mostly due to complications of transfusional haemosiderosis. However, even with the best available treatment, growth failure becomes apparent before puberty. In boys, there is usually a complete or partial failure of pubertal growth and sexual maturation. In girls the failure tends to be less severe with irregular or scanty menstrual periods. However, secondary amenorrhoea may develop from iron overload. Other effects may include endocrine, hepatic or renal failure and overt diabetes mellitus.

#### Case Study

A 1-year-old Asian boy presented with pallor, poor feeding, failure to thrive and recurrent upper respiratory infection. On examination he was anaemic and had a massive hepatosplenomegaly.

Haemoglobin was 5.2 g/dl, WBC and platelet counts were normal. Peripheral blood film showed markedly hypochromic, microcytic red cells, anisocytosis and target cells and some basophilic stippling. Reticulocyte count 10%. He had mildly raised unconjugated bilirubin; otherwise ALT and AST were normal.

The most likely diagnosis was beta thalassaemia major.

#### Treatment

The prognosis in beta thalassaemia has improved in recent years and could improve still further if the best available management were to be everywhere pursued. This has been well-described under three major categories:

1. Choice of transfusion scheme;
2. Hypersplenism and splenectomy and
3. Iron chelation therapy.

The objective of the transfusion scheme should be to maintain haemoglobin between 10 g/dl and 14 g/dl with pre-transfusion haemoglobin of 10–11 g/dl. Patients should have their red cells genotyped to reduce the risk of sensitisation due to repeated blood transfusions. This regimen will reduce the stimulus to unlimited bone marrow expansion and so prevent such undesirable manifestations as cardiomegaly, stunting of growth and the disfiguring Cooley's facies. This regimen has become standard therapy for beta thalassaemia major. On the other hand, the degree of hypersplenism has not always been appreciated and it may be marked even in the absence of thrombocytopenia or leucopaenia. Its presence greatly increases the blood requirements. The rate of splenic

enlargement is variable even in well-transfused patients and the massive size of the spleen may lead to abdominal discomfort. Often the transfusion requirement increases as the spleen enlarges. Eventually most patients undergo splenectomy which usually leads to improved physical well-being and a reduction in the transfusion requirement. Splenectomy should be delayed if possible until the child is 5 years of age because of the risk of post-splenectomy infection. Splenectomised children should receive life-long oral penicillin prophylaxis and polyvalent polysaccharide pneumococcal and Hib vaccine.

Desferrioxamine is the only effective agent available for chronic iron chelation. This should be commenced to prevent iron overload before the third birthday and when the infant is dry at night. Desferrioxamine can be administered subcutaneously overnight with a small infusion pump. There is also general agreement that ascorbic acid 100–200 mg daily by mouth enhances the effectiveness of desferrioxamine therapy. Ferritin levels should be used to monitor iron load.

Iron overload is responsible for cardiac, hepatic and endocrine problems which are reduced by chelation therapy. Due to the hypothalamic-pituitary dysfunction testosterone or oestrogen supplements may be indicated for hypogonadism. Growth hormone (GH) may also be required. Insulin is required for those who develop diabetes. Children will require folic acid supplements due to increased demands of increased erythropoiesis. Bone marrow transplantation is the only curable option for those with fully matched human leukocyte antigen (HLA) compatible sibling donors.

The only rational approach to thalassaemia on a world scale must lie in programmes developed towards prevention. These have been based on prospective detection of heterozygotes followed by genetic counselling.

### Beta Thalassaemia Minor and Thalassaemia Intermedia

The beta thalassaemia heterozygotes are asymptomatic. The haemoglobin is slightly reduced to 9–12 g/dl and the red cell count is high. On the contrary, patients with thalassaemia intermedia are symptomatic. They have a milder clinical course than those with thalassaemia major and are not blood transfusion dependent and should not be subjected to transfusion inappropriately.

### Sickle Cell Disease

#### *Aetiology*

This disease is almost confined to the black African races. It is one of the most prevalent autosomal recessive haemoglobinopathies. Homozygotes suffer from sickle cell anaemia in which all of their haemoglobin is of the

Hb-S variety (homozygous SS disease). The other sickling syndromes are the double heterozygous states such as Hb SC disease (HbSC) and sickle beta thalassaemia (Hb S Beta thal). The abnormality in Hb-S lies in the beta peptide chains, the alpha chains being normal. The aberration in the beta chains is due to the substitution of valine for glutamic acid in the No.6 position. Heterozygotes reveal the sickle cell trait (AS) and their haemoglobin is composed of about 60% Hb-A and 40% Hb-S. The trait is found in about 7–9% of American black people but it is much more prevalent in some African tribes. It provides increased resistance to malignant tertian malaria. Hb-S has a distinctive electrophoretic pattern which is due to its abnormal molecular structure. This type of haemoglobin forms crescent-shaped crystals under reduced oxygen tension and it is this property which is responsible for the sickled shape of the erythrocytes in people who possess the gene. Haemolysis in sickle-cell anaemia appears to be due mainly to impaction of the sickled cells in the capillaries, especially in organs where the oxygen tension is low. Capillary obstruction leads to infarcts in various organs, e.g. spleen, intestine, bones, kidneys, heart, lungs and brain.

#### Key Learning Point

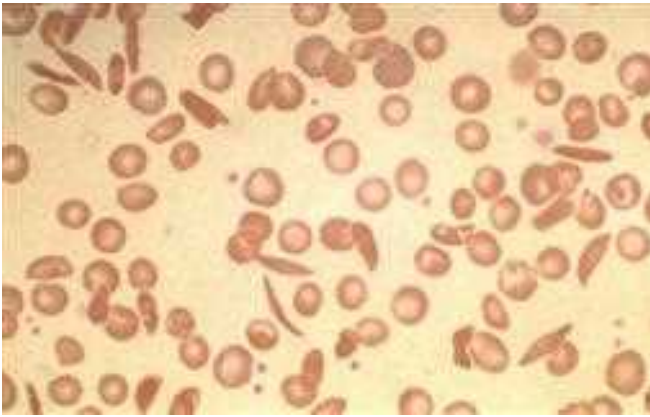
- Most infants with sickle cell disease (SS) are functionally asplenic by 1 year of age because of repeated splenic infarction.

### Clinical Features

The sickle cell trait (AS) is symptomless unless it is associated with another haemoglobinopathy or with thalassaemia. Sickle cell anaemia (SS) often presents during the first year with pallor, listlessness and mild jaundice, but not before 6 months of age. The onset of symptoms is, however, delayed for 6 months or longer until the Hb-F of the infant has been replaced by Hb-S. In some cases, there are recurrent haemolytic crises with acute symptoms such as severe abdominal pain and rigidity, pain in the loins, limb pains, localised paralyses, convulsions or meningism. Cerebrovascular occlusion can lead to hemiplegia and cranial nerve palsies.

The lung is also one of the major organs involved in sickle cell disease. Clinical lung involvement commonly takes two major forms: (1) the acute chest syndrome and (2) sickle cell chronic lung disease. Acute chest problem is manifested by fever, chest pain and infiltrates in the chest radiograph. Chronic lung disease is due to repeated episodes of infection and infarction.

Symmetrical painful swellings of the fingers and feet (hand foot syndrome-dactylitis) may develop due to infarction of the metacarpals and metatarsals. X-rays show severe bone destruction and periosteal reaction. They may also reveal



**Fig. 15.8:** Peripheral blood smear of a child with sickle cell disease showing sickled red cell

radial striations in the skull. Chronic haemolytic anaemia interferes with growth and nutrition so that the child is often stunted in later years. Splenomegaly may be marked, but sometimes disappears in later childhood. Cholelithiasis may develop as in other haemolytic anaemias. In adults the large joints may become swollen and painful with serious crippling. The peripheral blood shows a normochromic anaemia, reticulocytosis and polymorphonuclear leucocytosis. In addition there is an increase in the serum unconjugated bilirubin and a decrease in red cell osmotic fragility. In a crisis excess urobilinogenuria is marked. Sickled cells may be seen in ordinary blood films (Fig. 15.8). The diagnosis can be confirmed by demonstration of the characteristic mobility of Hb-S on starch gel electrophoresis. Children affected with SS also have some Hb-F in their circulation.

#### Case Study

A 3-year-old Nigerian boy presented with pallor and a painful swollen right index finger. On abdominal examination he had splenomegaly 4 cm below the left costal margin. Most likely diagnosis is sickle cell disease with dactylitis.

#### Treatment

There is no cure for sickle cell disease but blood transfusions are frequently required for anaemia. Due to the high incidence of serious bacterial infections in patients with SS, the index of suspicion for infection should be high. Antibiotic choice should include agents effective against *pneumococcus*, *Haemophilus influenzae*, *Salmonella* and *Staphylococcus aureus*. The risk of pneumococcal infection in particular is high in the first 2 years of life. Therefore penicillin prophylaxis should be started by the age of 4 months. Pneumococcal vaccine, *haemophilus influenzae* type b vaccine, an annual influenza vaccine and prophylactic penicillin reduce the risk of infection. Hepatitis B vaccine should be considered if the child is not immune. In vaso-

occlusive crises, rest in bed and relief of pain are essential. The pain of mild sickle-cell crises is managed with paracetamol, an NSAID, codeine or dihydrocodeine. Severe crises may require the use of morphine or diamorphine. Dehydration and acidosis should be quickly corrected. With careful supervision and the use of blood transfusion many children with sickle cell anaemia (SS) reach adult life. Splenectomy is indicated when there is evidence of hypersplenism. Folate deficiency is particularly common in sickle-cell disease and 5 mg of folic acid should be given daily. Death can occur suddenly from cardiac failure, renal failure or cerebral infarction and patients of black African extraction should always be tested for sickling before anaesthesia. Sickle cell testing is an important consideration in any child from geographical areas where sickle cell disease is prevalent before any elective surgery is carried out. Postoperative preparation may require blood transfusion and hypoxia and acidosis should be avoided during the operation. Antenatal diagnosis can be made on chorionic villous biopsy in the first trimester of pregnancy. At present the role of bone marrow transplantation is limited. Some patients benefit clinically from hydroxyurea. Hydroxyurea can reduce the frequency of crises and the need for blood transfusions. Some children with sickle cell disease may suffer from delayed puberty and may require sex hormone replacement therapy.

#### Other Haemoglobinopathies

It has already been noted that there are three normal haemoglobins each of two identical pairs of globin polypeptide chains with an iron-containing haem group inserted into each chain. In the healthy adult 98% of the Hb-A is composed of two alpha and two beta chains ( $\alpha_2\beta_2$ ). About 2% of adult Hb is Hb-A<sub>2</sub> composed of two alpha and two delta chains ( $\alpha_2\delta_2$ ). Foetal Hb or Hb-F is composed of two alpha and two gamma chains ( $\alpha_2\gamma_2$ ). However, over 100 abnormal haemoglobins have now been recognised in which the aberration generally consists of a single amino acid substitution in one pair of the peptide chains due to gene mutation. That is to say, they are determined by alleles of the genes for normal Hb-A, Hb-A<sub>2</sub> or Hb-F. The different haemoglobins carry different electrical charges so causing them to move at different speeds in an electrical field and they can usually best be identified by electrophoresis. The different haemoglobinopathies vary widely in their effects, from no apparent effect on health to a fatal disease (e.g. Hb-S). The homozygote for the gene will, of course always be much more severely affected than the heterozygote, as in sickle-cell disease.

The homozygote for Hb-C presents with manifestations similar to those in SS but sickling and bone changes do not occur. The heterozygote is usually symptomless but blood films show target cells and there is increased osmotic



resistance. The homozygote for Hb-E on the other hand, suffers only from a mild normochromic anaemia with numerous target cells and increase in osmotic resistance, while the heterozygote is asymptomatic. Haemoglobin M disease is very different in that it causes methaemoglobinemia.

Having now considered thalassaemia and a few of the haemoglobinopathies in both the homozygous and heterozygous forms, it remains to point out that some anaemic children are found to have inherited the genes for two abnormal haemoglobins, one from each heterozygous parent, or more commonly for beta thalassaemia and one abnormal haemoglobin. They are, in fact, mixed or double heterozygotes. Thus there has been described beta thalassaemia with haemoglobin S (or C, D or E) as well as S/C, S/D combinations, etc. The effects produced by these states depend upon the peptide chains involved. Thus, if both abnormal genes affect the same type of chain the effects are much more severe than if they affect different chains, i.e. the mixed heterozygous state is more crippling than the double heterozygous state. For example, in both S/C disease and Hb-S/beta thalassaemia the beta chains are involved. This means that no Hb-A can be formed because no normal beta chains can be produced, a state called "interaction" and the resulting clinical manifestations are very similar in severity to the homozygous S/S state (sickle cell anaemia). On the other hand, when both an alpha and a beta chain abnormality are inherited (e.g. as in alpha thalassaemia with beta chain haemoglobins S, C or E) the effect is usually no more severe than when only one of the abnormalities is present because no "interaction" has taken place. Some of these abnormal haemoglobin states can only be accurately identified by family studies, employing sophisticated techniques. The matter is of practical importance because of the differences in prognosis.

### Glucose-6-Phosphate Dehydrogenase Deficiency

Glucose-6-phosphate dehydrogenase (G-6-PD) deficiency is the most common red blood cell enzyme abnormality associated with haemolysis. More than 300 types of G-6-PD have been described. Most of these variants are enzymatically normal and are not a cause of clinical problems. It affects people throughout the world with the highest incidence in individuals originating from most parts of Africa, from most parts of Asia, from Oceania and from Southern Europe. G-6-PD deficiency is more common in males than it is in females.

Glucose-6-phosphate dehydrogenase A is the commonest variant associated with haemolysis and is found in 10–15% of African-Americans. G-6-PD B is the normal enzyme found in Caucasians and many Negroes. G-6-PD Mediterranean is the commonest variant in white people of Mediterranean origin and G-6-PD Canton is the commonest cause of G-6-

PD deficiency in Asians. It is X-linked and haemolysis is mainly confined to males. The magnitude of haemolysis is variable and is dependent on the degree of oxidant stress. Most variants of G-6-PD deficiency cause acute haemolysis and not chronic haemolysis on taking a number of common drugs. They are also susceptible to developing acute haemolytic anaemia upon ingestion of fava beans (broad beans, *Vicia faba*); this is termed favism and can be more severe in children or when the fresh fava beans are eaten raw.

The diagnosis of G-6-PD deficiency is suggested by Coomb's negative haemolytic anaemia associated with drugs or infection. The specific diagnosis of G-6-PD deficiency can be made by spectrophotometric enzyme measurements. Special stains of the peripheral blood may reveal Heinz bodies during haemolytic episodes.

**Box 15.3:** Drugs commonly associated with acute haemolysis in most G-6-PD deficiency individuals

- Primaquine
- Pamaquine
- Sulphanilamide
- Sulphapyridine
- Sulphamethoxazole
- Salazopyrin
- Septrin
- Dapsone
- Thiazolesulphone
- Nitrofurantoin
- Nalidixic acid
- Naphthalene in mothballs, menadione, methylene blue, quinidine, quinine, Rasburicase

### Pyruvate Kinase Deficiency

Pyruvate kinase deficiency is the commonest red cell enzyme deficiency in north Europeans. It presents in the neonatal period with anaemia and jaundice. Diagnosis requires measurement of pyruvate kinase in the red blood cells (RBC). The degree of haemolysis varies greatly and is sometimes severe enough to require frequent RBC transfusions. There is a beneficial response to splenectomy.

## AUTOIMMUNE HAEMOLYTIC ANAEMIA

### Aetiology

This is not a common problem in paediatric practice but it may present as an acute emergency. There are two major classes of antibodies against red cells that produce haemolysis in man; (1) IgG and (2) IgM. Autoimmune haemolytic anaemia (AIHA) can be warm or cold antibody type. The IgM antibody is generally restricted to the clinical entity of cold haemagglutinin disease because it has a particular affinity

for its red cell antigen in the cold (0°–10°C). IgM-induced immune haemolytic anaemia is most commonly associated with an underlying mycoplasma infection or cytomegalovirus, mumps and infectious mononucleosis infections.

The IgG antibody usually has its maximal activity at 37°C and, thus, this entity has been termed warm antibody induced haemolytic anaemia. IgG-induced immune haemolytic anaemia may occur without an apparent underlying disease (idiopathic disease); however, it may also occur with systemic lupus erythematosus (SLE), rheumatoid arthritis and certain drugs. Warm type AIHA can be severe and life-threatening.

### *Clinical Features*

In some children the disease has an alarmingly acute onset with fever, backache, limb pains, abdominal pain, vomiting and diarrhoea. Haemoglobinuria and oliguria may be present. Pallor develops rapidly and icterus is common. Frequently, the pallor, listlessness and mild icterus develop more insidiously. Splenomegaly is common. The urine may be dark in colour due to the presence of excess urobilinogen. Reticulocytosis is often marked and there may be many erythroblasts in the peripheral blood. Spherocytosis with an increased fragility of the red cells may simulate congenital spherocytosis. However, in acquired haemolytic anaemia Coombs' test is positive and serum unconjugated bilirubin concentration is increased.

### *Treatment*

In many patients with IgG or IgM-induced immune haemolytic anaemia no therapeutic intervention is necessary, since the haemolysis may be mild. However, in some children with significant anaemia complete recovery follows emergency blood transfusion. In less acute cases the haemolytic process continues after transfusion. Corticosteroids are of great value in the treatment of AIHA. Oral prednisolone 2 mg/kg per day should be given until the haemolysis is brought under control. Thereafter, the dosage is progressively reduced to achieve the smallest maintenance dose compatible with a reasonable haemoglobin value (10–12 g/dL). When long-term steroid therapy proves necessary a careful watch must be kept for undesirable side-effects such as osteoporosis, diabetes mellitus, etc. When haemolysis cannot be controlled with a reasonable dosage of steroid, the question of splenectomy arises. Prolonged courses of corticosteroids increase susceptibility to infections and severity of infections; clinical presentation of infections may also be atypical. Unless they have had chickenpox, children receiving oral or parenteral corticosteroids for indications other than replacement should be considered as being at risk of having severe chickenpox. Therefore, passive immunization with varicella-zoster

immunoglobulin is indicated for exposed non-immune children.

In children who do not respond to steroids, immunosuppression has been used, e.g. cyclosporin, cyclophosphamide and high dose intravenous immunoglobulin. Blood transfusion may be required.

## **PAROXYSMAL NOCTURNAL HAEMOGLOBINURIA**

Paroxysmal nocturnal haemoglobinuria (PNH) tends to occur in young adult men and is extremely rare in children. As the name suggests, there is a haemolytic anaemia and the urine often contains haemosiderin and may also contain haemoglobin. Patients develop iron deficiency due to haemosiderinuria. Bone marrow transplantation may be curative.

## **MICROANGIOPATHIC HAEMOLYTIC ANAEMIA**

This condition refers to red cell fragmentation and damage in the microcirculation and appears to be the result of small-vessel disease in part due to endothelial damage and the presence of fibrin strands. In children the most common cause is haemolytic uraemic syndrome (HUS), although it is sometimes seen in children with burns and following the insertion of some types of heart valve prostheses.

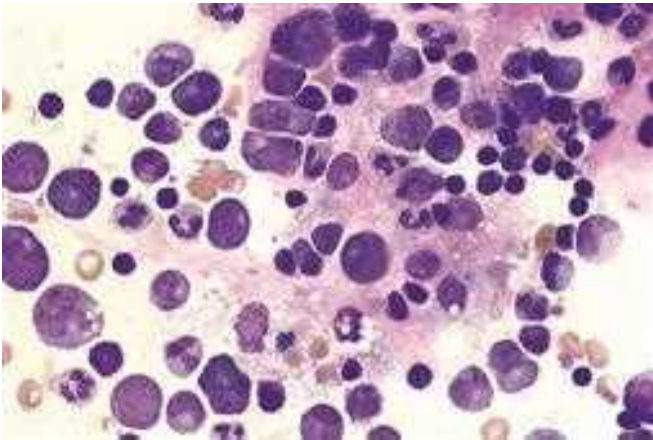
## **APLASTIC AND HYPOPLASTIC ANAEMIA**

This group of anaemias is poorly understood and clearly contains a considerable number of quite separate diseases which present clinically in somewhat similar ways. The defect in erythropoiesis may affect all elements of the marrow or only one, such as the erythropoietic tissue. There may be virtually no formation at all of the precursors or red cells, leucocytes or platelets. Fortunately, these conditions are not common, but those to be considered here occur sufficiently frequently in paediatric practice to merit the attention of all who have to handle sick children.

## **CONGENITAL HYPOPLASTIC ANAEMIA (BLACKFAN DIAMOND ANAEMIA)**

### **Aetiology**

This disease presents in early infancy as an apparent aplasia of the red cells. Granulocytes and platelets are unaffected. In most cases, the bone marrow shows a gross deficiency of erythroblasts but shows normal maturation of myeloid and megakaryocyte cells. The incidence is the same in boys as in girls but the disease tends to be milder in its effects on boys. Its occurrence in siblings has been reported in several



**Fig. 15.9:** Marrow film of a child with Blackfan Diamond anaemia—virtually no red cell precursors on the film

families and family studies have suggested an autosomal recessive mode of inheritance.

### Clinical Features

The presenting feature is pallor, which becomes apparent in the early weeks or months of life. Irritability becomes obvious only when the anaemia is severe in degree. Short stature is common and characteristic facial features are described of a snub nose, wide-set eyes and a thick upper lip. There are no haemorrhagic manifestations. Hepatic or splenic enlargement is unusual but may develop as a consequence of cardiac failure. Haemic systolic murmurs are common. The anaemia, often severe, is normocytic and normochromic. Reticulocytes are absent or scanty. White blood cells and platelets show no abnormalities (Fig. 15.9).

### Course and Prognosis

This is greatly influenced by treatment. Repeated blood transfusions lead to haemosiderosis which causes typical muddy bronze skin pigmentation. Cirrhosis of the liver ultimately develops with failure of sexual maturation. Portal hypertension and hypersplenism occasionally develop. The long bones often show marked growth-arrest lines. Osteoporosis and delayed bone age are common. Affected children are frequently dwarfed but mental development proceeds normally. The prognosis is not good in the long-term; on the other hand, spontaneous remissions have frequently been reported, even after puberty and several hundred transfusions.

### Treatment

Repeated transfusions of packed red cells, always after careful cross-matching, are frequently required over periods of many years. In some cases there is a marrow response

to prednisolone in an initial dose of 2 mg/kg per day in four divided doses, but only if treatment is started before 3 months of age. The dosage should thereafter be reduced to the smallest that will maintain a reasonable haemoglobin level and normal reticulocyte count and is given on alternate days. When repeated transfusions are necessary the development of haemosiderosis can be delayed with the iron chelating agent desferrioxamine to treat iron overload. In these children, bone marrow transplantation may be considered.

## FANCONI-TYPE FAMILIAL APLASTIC ANAEMIA

### Aetiology

This autosomal recessive disorder affects all three elements of the bone marrow (pancytopenia). Chromosomal studies in some cases have revealed an abnormally high number of chromatid breaks, endoreduplications and other minor abnormalities.

### Clinical Features

Pallor may become obvious in early infancy, but more often the onset is delayed until between the ages of 3 and 10 years. Purpura and ecchymoses are not uncommon and there may be bleeding from mucous membranes. Defects in the radius and/or thumb or accessory thumbs are common. Mild hyperpigmentation, hypogonadism and short stature have frequently been reported and endocrine studies have revealed GH deficiency, isolated or combined with deficiencies of gonadotrophins and adrenocorticotrophic hormone (ACTH). Other congenital abnormalities are seen less frequently include microcephaly, squints and anomalies of the heart or renal tract. The blood shows a normocytic, normochromic anaemic, leucopaenia, granulocytopenia and thrombocytopenia. Reticulocytes are scanty or absent. Leukaemia not infrequently appears in relatives and occasionally in the patient. The diagnosis is readily overlooked in patients who lack the characteristic congenital abnormalities, but useful diagnostic pointers are the presence of Hb-F, 1–2 g/dL in the blood and of chromosomal abnormalities in the lymphocytes.

### Treatment

Repeated blood transfusions may be necessary in spite of the risks of transfusion haemosiderosis. Death is common during childhood but a sustained remission can sometimes be obtained with a combination of prednisolone 0.4 mg/kg on alternate days and oxymetholone 2–5 mg/kg daily. The latter drug can give rise to hepatoblastoma. Therapy with human growth hormone (HGH) may cause an increase in growth velocity if a deficiency of GH has been

confirmed. Also successful bone marrow transplantation has been reported in patients with Fanconi's anaemia.

## ACQUIRED HYPOPLASTIC ANAEMIA

This is a rare disease in childhood and most cases are "idiopathic". The bone marrow is rarely completely aplastic in such patients. Some cases are secondary to the toxic effects of drugs such as chloramphenicol, phenylethylacetylurea, carbimazole, thiouracil, phenylbutazone and gold salts.

### Clinical Features

The onset may be acute or insidious with increasing pallor, listlessness, malaise, bruises, purpura and sometimes bleeding from mucous membranes. Death is due to haemorrhage into internal organs or to intercurrent infection. The blood shows a normocytic, normochromic anaemia, thrombocytopenia, leucopaenia and granulocytopenia. Bone marrow must always be examined by needle biopsy or trephine. Marrow examination is, furthermore, the only way in which hypoplastic anaemia can be distinguished from aleukaemia to leukaemia. The prognosis is grave when the marrow examination reveals gross hypoplasia of all the blood forming elements, but in less severe cases there is always hope of a spontaneous or induced remission.

### Treatment

Life can be prolonged by repeated transfusions of packed red cells. Platelet transfusions can also help to prolong life. Remissions can sometimes be obtained with a combination of prednisolone and oxymetholone as described for the treatment of Fanconi's anaemia. Antilymphocytic immunoglobulin given intravenously via a central line over 12–18 hours each day for 5 days produces a response in about 50% of cases of acquired hypoplastic anaemia; the response rate may be increased when ciclosporin is given as well. However, the treatment of choice is bone marrow transplantation from histocompatible sibling or family donor. Bone marrow transplantation is more likely to be successful if blood transfusions have been irradiated and kept to a minimum to avoid sensitisation to donor transplantation antigens.

## ALBERS-SCHÖNBERG DISEASE (OSTEOPETROSIS, MARBLE BONES)

### Aetiology

This is a genetic disorder of bone, usually autosomal recessive. The cortex and trabeculae of the bones are thickened and the marrow is crowded out. Extramedullary erythropoiesis in the liver and spleen may prevent anaemia for a variable period. It is now recognised that the cause of osteopetrosis

is a defect or deficiency of osteoclasts or their precursors which are derived from the pluripotent haemopoietic stem cells. Bone resorption is inhibited.

### Clinical Features

The disease may present in infancy with progressive loss of vision due to optic atrophy, with cranial nerve palsies or with deafness. In later childhood the mode of presentation is a pathological fracture or increasing pallor. The anaemia is leucoerythroblastic in type. There is progressive hepatosplenomegaly. The most characteristic diagnostic signs are to be found in radiographs of the skeleton (Figs 15.10A to C). The bones, including the base of the skull, ribs, vertebrae, scapulae and pelvis show increased density. Typical zones of decreased density can be seen at the metaphyses and running parallel to the borders of scapulae and ilia; these still contain marrow. This disease should be differentiated from pyknodysostosis. This is an autosomal recessive disease that resembles osteopetrosis except that the clinical manifestations are mild and not associated with haematologic or neurologic abnormalities.

### Treatment

It is now possible to cure some infants with the severe form of the disease by bone marrow transplantation from a histocompatible sibling. Infants with compatible donors should be transplanted as early as possible to avoid irreversible damage from bone encroachment on cranial nerves.

## THE THROMBOCYTOPAENIC PURPURAS

Purpura is an extremely common clinical phenomenon in childhood and has many causes. The principal pathogenic factors are capillary defects and thrombocytopenia, sometimes both being present. In most cases the purpura is symptomatic of another disease. It occurs due to decreased capillary resistance or bacterial micro-emboli in acute infections such as meningococcal (and other) septicaemia, bacterial endocarditis, typhus and typhoid fever, scarlet fever, etc. It may arise in scurvy, uraemia and snake-bite. Severe intrapartum hypoxia sometimes causes petechiae, especially over the head, neck and shoulders of the newborn. A similar mechanical effect is sometimes seen in the child who has had a severe and prolonged convulsion and in whooping cough. Symptomatic thrombocytopenic purpura occurs in leukaemia, hypoplastic anaemia and in states of hypersplenism. Fragmentation of platelets as well as red cells, with thrombocytopenia and haemolytic anaemia may occur in cases of giant haemangioma and after cardiac surgery. Congenital defects in the capillaries are seen in such rare conditions as hereditary haemorrhagic telangiectasia (Osler's disease) and cutis hyperelastica



(Ehlers-Danlos syndrome). It will be clear, therefore, that purpura reflects a blood disorder in only a minority of cases. Nonetheless, the more important primary diseases in which purpura is a prominent feature are conveniently discussed in this chapter.

### IDIOPATHIC THROMBOCYTOPAENIC PURPURA

Idiopathic thrombocytopaenic purpura (ITP) accounts for the majority of cases of childhood thrombocytopaenia and has been classified into acute and chronic forms. It is a clinical diagnosis reached by exclusion of other causes of thrombocytopaenia (Table 15.3).

**Table 15.3:** Thrombocytopaenia in childhood

<i>Disorders of production</i>	<i>Disorders of destruction</i>	<i>Abnormal distribution</i>
Leukaemia	DIC	Giant haemangioma
Solid tumour	HUS	
Aplastic anaemia	Acute ITP	
TARS	Chronic ITP	
Drug induced	Autoimmune diseases (SLE)	
e.g. cytotoxic therapy, sodium valproate, phenytoin carbamazepine	TTP Intravascular prosthetic devices INTP	

- DIC = Disseminated intravascular coagulation
- HUS = Haemolytic uraemic syndrome
- ITP = Idiopathic thrombocytopaenic purpura
- TTP = Thrombotic thrombocytopaenic purpura
- TARS = Thrombocytopaenia with absent radius syndrome, Giant haemangioma, Kasabach-Merritt syndrome
- INTP = Iso-immune neonatal thrombocytopaenic purpura

### Clinical Features

Most cases in childhood have an acute onset. The peak age is 2–4 years with a male:female ratio of 1:1. There has frequently been a recently preceding, non-specific upper respiratory infection or other common childhood illness and immunisations have been associated. The first manifestation may be bleeding from mucous membranes such as epistaxis, bleeding gums or haematuria. Generalised purpura and/or ecchymoses are characteristic and often profuse. The spleen may be palpable but never becomes very large. Life may be endangered in severe cases by blood loss or by subarachnoid haemorrhage. The differentiating characteristic of this acute form is the spontaneous and permanent recovery within 6 months of onset.

**Figs 15.10A to C:** (A) Osteopetrosis showing zones of increased density at metaphyseal ends of long bones, (B) Face spectacles or showing "White spectacle sign", (C) Showing increased density in ribs

**Key Learning Points**

- ➔ Meningococcal septicaemia comes into differential diagnosis of a widespread petechial rash but is unlikely in a well-child
- ➔ Non-accidental injury with bruises is unlikely because of the abnormal platelet count.

Chronic cases are also seen in which crops of purpura and ecchymosis persist beyond 6 months and occur more frequently in girls. Children who have the chronic form of ITP may present at any age, although children over 10 years of age are at a greater risk than those in the younger age group. The blood shows a diminished platelet count. Spontaneous bleeding can occur when the count will be low and often is less than  $10 \times 10^9/L$ . The WBC and haemoglobin are normal. Blood film shows no abnormality other than the absence of platelets.

A bone marrow examination is needed only when there is an atypical presentation or abnormalities other than absent platelets on the blood film or if steroids are going to be used as treatment (Fig. 15.11).

**Case Study**

A 6-year-old girl presented with a 48 hours history of bruises on her legs and numerous petechiae over face and chest. She had epistaxis a few hours prior to hospitalisation. She had no previous history of easy bruising or being on any medication. In fact she had been previously healthy. On examination she had widespread petechiae. She had no other positive finding and in particular had no lymphadenopathy or hepatosplenomegaly. Haemoglobin was 12.5 g/dL, WBC  $10.6 \times 10^9/L$ , neutrophil count  $5.6 \times 10^9/L$  and platelet count  $1.5 \times 10^9/L$ . The blood film except for the absence of platelets was normal. Immunoglobulin was normal. Blood urea, creatinine and U and Es normal.

The most likely diagnosis in this girl with isolated thrombocytopenia is ITP

**Treatment**

Unfortunately the clinician cannot predict whether a given child will have the more common acute self-limiting form, develop a chronic course, or be in the 1% of children who have their course complicated by a sudden spontaneous life-threatening GI or central nervous system (CNS) haemorrhage. However, in most children the acute attack of thrombocytopenic purpura undergoes spontaneous remission within 6 months and does not again appear. There is rarely any need for a quick decision about some form of specific treatment. Despite very low platelet counts of even less than  $10 \times 10^9/L$ , major haemorrhage is rare and only symptoms are usually bruising. The patient should be treated and not the platelet count. Life-threatening intracranial haemorrhage



**Fig. 15.11:** Bone marrow of a child with idiopathic thrombocytopenic purpura—showing excess megakaryocytes

is a very rare event. When bleeding is severe and persistent, blood transfusion combined with steroid therapy is usually successful in initiating a remission. This may be permanent or temporary. However, corticosteroid treatment should not be continued longer than 14 days regardless of the response. Platelet transfusions should be used only when life-threatening bleeding episodes occurs, since they achieve only a transient haemostatic response. Intravenous administration of very large doses of human normal immunoglobulins (HNIG) also can lead to a rapid but usually transient rise in platelet count. Therefore intravenous immunoglobulin does not seem to be indicated as the therapy of choice in the acute phase of ITP. Elective splenectomy is followed by permanent return of the platelets to normal levels in only about 80% of cases. For this reason, authors have been reluctant to recommend it unless the disease is persistent or there are repeated acute attacks. Other therapy that has been tried in refractory ITP include azathioprine, cyclophosphamide, vincristine and cyclosporin. Rituximab has also been used but experience of its use in children is limited. For children with chronic severe thrombocytopenia refractory to other therapy, tranexamic acid may be given to reduce the severity of haemorrhage.

**NEONATAL THROMBOCYTOPENIC PURPURA**

It is well-recognised that the infant of a mother who is suffering from ITP or thrombocytopenia secondary to SLE may be born with severe thrombocytopenia. The infant usually exhibits generalised purpura and during the first few days of life there is a risk of severe haemorrhage into organs such as the brain, adrenals or pericardium. The pathogenesis has been shown to be the transplacental passage of antibodies which are directed against antigens common to all platelets. If the infant's platelet count falls below  $10 \times 10^9/L$ , prednisolone 2 mg/kg per day should be prescribed for 2–3 weeks with later reduction of the dosage. This type of neonatal thrombocytopenia has to be

differentiated from neonatal, isoimmune thrombocytopenia in which there is foeto-maternal incompatibility for a platelet antigen absent in the mother and expressed on the foetal platelet membranes (INTP). The mother is platelet antigen (PLA-1) negative and anti-platelet antibodies pass to the foetus and destroys the foetal platelets. The situation is analogous to Rh or ABO incompatibility, but there are as yet no reliable tests to predict the birth of an affected baby during pregnancy. In contrast to Rh sensitisation, first born infants may be affected and the risk of recurrence in future pregnancies is high. The diagnosis can be confirmed by the demonstration of antiplatelet antibodies in the maternal serum. These tests, together with a normal maternal platelet count and the exclusion of other known causes of neonatal thrombocytopenia (e.g. neonatal infection—including TORCH infections—toxoplasmosis, rubella, CMV, herpes simplex, syphilis, disseminated intravascular coagulation, drug induced or autoimmune thrombocytopenia) often establish the diagnosis of neonatal isoimmune thrombocytopenia. The best form of treatment is probably transfusion of platelets lacking the offending antigen, i.e. only the mother's platelets, which can be obtained by plateletpheresis. Exchange transfusion, steroids and intravenous immunoglobulins have also been used but the more effective treatment remains the transfusion of compatible platelets.

### WISKOTT-ALDRICH SYNDROME

This is a rare X-linked recessive disorder affecting only males. It is characterised by the triad of severe thrombocytopenia, eczema and immunodeficiency. The majority of children die from overwhelming infection at an early age. Those who survive may develop reticuloendothelial malignancies such as lymphoma and myeloid leukaemia. The usual mode of presentation is during infancy with typical atopic eczema which may later be superseded by asthma. The bleeding tendency results in purpura or oozing from mucous membranes. Infections such as otitis media, pneumonia, septicaemia, meningitis and virus diseases constitute the major threat to life. Recent studies have revealed an immunological deficiency in this disease involving both humoral and cellular immunity. There is absence or reduction in isoagglutinins, progressive lymphopaenia and failure to produce antibodies to some antigens after an appropriate challenge.

### Treatment

Apart from blood and platelet transfusions little could be done for children with this disease until recently. There is a good response to splenectomy. Therefore in spite of the risks of splenectomy in an immunocompromised child, splenectomy may be justified. Otherwise bone marrow transplantation is the only curative treatment for this disease.

### HENOCH SCHÖNLEIN PURPURA

See chapter 16 on Rheumatology.

### BLOOD CLOTTING DEFECTS

The mechanism of blood clotting is extremely complex and modern tests used to define the various congenital and acquired defects in this mechanism are only for the expert haematologist. The paediatrician must, however, have sufficient knowledge of the clinical types of clotting deficiency to use rationally the help which the haematologist has to offer.

### The Blood Coagulation Cascade and Screening Tests of Homeostasis

The classical blood coagulation cascade involves the intrinsic pathway and the extrinsic pathway. Although the mechanism of blood clotting is extremely complex it is easier to understand it under these two headings. Intrinsic blood coagulation is initiated by contact of the flowing blood with a foreign surface while the extrinsic pathway is thought to be primarily responsible for initiating haemostasis as shown in Figure 15.12.

### Screening Tests

Screening tests of haemostasis include platelet count, the bleeding time—measures platelet function and interaction with vessel wall and clotting factors such as fibrinogen and factor VIII. The precise diagnosis of each coagulation disorder may require very sophisticated coagulation tests.

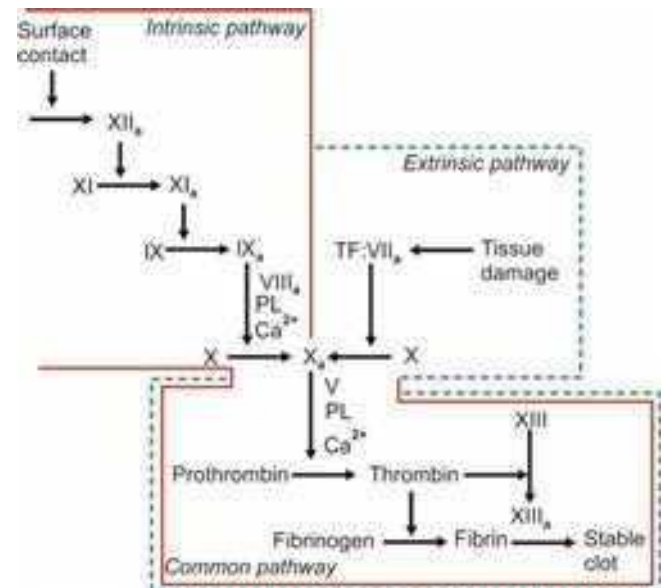


Fig. 15.12: Diagrammatic representation of the coagulation cascade

The prothrombin time (PT) measures the extrinsic pathway (factors VII, X, V, II and fibrinogen) and the activated partial thromboplastin time (APTT) measures the intrinsic pathway (measures the coagulation activity of factors XII, HMWK, PK, XI, IX, VIII, X, V, II and fibrinogen). The thrombin clotting time (TCT) measures the conversion of fibrinogen to fibrin. It is prolonged when fibrinogen is low from consumption, in hypo/dysfibrinogenaemia, in the presence of heparin and fibrin degradation products (FDPs)/D-dimers. Direct estimation of fibrinogen is included since PT, APTT, TCT are insensitive to levels of fibrinogen over 100 mg/dl.

## HAEMOPHILIA A

### Aetiology

Haemophilia A is the second most common inherited haemorrhagic disorder occurring in all ethnic groups. Deficiency of functionally active factor VIII is inherited as an X-linked recessive trait affecting males. Affected females are extremely rare.

### Clinical Features

It is rare for haemophilia to become manifest during the first year of life. The outstanding feature is bleeding. The clinical severity of the condition is highly variable. It is classified according to the plasma concentration of factor VIII; Severe less than 1 IU/dL, moderate 1–5 IU/dL and mild more than 5 IU/dL. This may take the form of prolonged oozing from a minor injury such as a cut lip or finger, from an erupting tooth, after the loss of a deciduous tooth or from the nose. There may be dangerous and persistent bleeding from circumcision or tonsillectomy if haemophilia has not been discovered. A common event is severe haemarthrosis, especially in a knee-joint after quite minor strain. A blow may result in a massive haematoma on any part of the body. A deeply situated haematoma may threaten life by pressure on vital structures such as the trachea or a large artery. In some children who are severely affected repeated haemarthroses may lead to fibrous ankylosis and crippling (Figs 15.13A and B). Bleeding from GI or renal tracts is not rare. Cases vary considerably in severity but run true to type within each individual family. There is a fairly high mutation rate, and the absence of a family history of "bleeders" does not exclude the diagnosis.

## HAEMOPHILIA B (CHRISTMAS DISEASE)

### Aetiology

Deficiency of factor IX is inherited as an X-linked recessive trait. It accounts for about 15% of all "bleeders", being much less common than true haemophilia A.



**Figs 15.13A and B:** (A) AP and (B) lateral view of the knee showing marked enlargement of the epiphyses around the knee, narrowing of the joint space, mild periarticular osteopaenia, widening of the intercondylar notch and mild increase in the soft tissue density within the joint itself, corresponding to haemosiderin deposition

### Clinical Features

The disease cannot be distinguished from haemophilia A on clinical grounds.

### Diagnosis of Haemophilia A and B

Both in haemophilia A and B APTT are prolonged because of the low levels of either Factor VIII or Factor IX. But estimating factor VIII or factor IX levels will help in confirming the diagnosis and classifying the severity. In haemophilia A the von Willebrand factor (vWF):Ag and ristocetin co-factor activity (measurement of vWF activity) are normal. In both haemophilia A and B the bleeding time and PT are normal.

## VON WILLEBRAND DISEASE

### Aetiology

Von Willebrand disease (vWD) is caused by a deficiency or defect of vWF, which is responsible for the adherence of platelets to damaged endothelium. This bleeding disorder has been recognised with increasing frequency in children in recent years. It is inherited as an autosomal dominant characteristic and thus affects both sexes equally. The gene is situated on chromosome 12.

### Clinical Features

The haemorrhage is of the "capillary" type rather than the "clotting deficiency" type as seen in haemophilia. Common



presenting features include epistaxis, prolonged bleeding from cuts or dental extractions and excessive bruising. GI bleeding can occasionally be alarming and menorrhagia may be a problem in the adult.

### Diagnosis

The bleeding time is prolonged because of abnormal platelet adhesion. The APTT is prolonged relative to the reduction in factor VIII. The vWF:Ag and ristocetin co-factor activities (measurement of vWF activity) are reduced. The PT is normal.

### Management of Haemophilia A, Haemophilia B and Von Willebrand Disease

- All children who are likely to require blood products on a regular basis should be vaccinated against hepatitis A and B.
- Alternatives to blood products should be used if appropriate and, when not, recombinant products should be used to avoid the risk of viral transmission.
- Most children with severe haemophilia A will need Factor VIII concentrate and this should be recombinant. Factor VIII 1 U/kg will raise the Factor VIII:C level by 2 IU/dL and has a half-life of 8–12 hours. For mild haemorrhage a level of 30 IU/dL is required, for established haemarthrosis a level of around 50 IU/dL and for surgery 80–100 IU/dL are recommended.
- Haemophilia B replacement therapy will need Factor IX concentrate. Factor IX concentrate 1 U/kg will raise the FIX:C level by approximately 1 IU/dL and the half-life is about 24 hours. Minimum level of FIX:C of 20 IU/dL is necessary for early bleeding episodes, 40 IU/dL for more advanced muscle or joint bleeding and an initial level of 60 IU/dl for surgery.
- Treatment of mild vWD is with desmopressin if this has been shown to raise the vWF and FVIII:C into a haemostatic range. If not, treatment is with vWF concentrates or FVIII concentrates, which contain adequate amounts of vWF. By definition, these will not be FVIII recombinant products and should be virucidal treated.
- Boys with severe haemophilia A and B generally receive prophylactic treatment thrice and twice weekly, respectively. This will greatly reduce the frequency of bleeds and thus chances of reduced arthropathy.
- About 10% of boys with haemophilia A may develop antibodies to FVIII:C when FVIII replacement fails to stop bleeding. Recombinant FVIII is now used to bypass the inhibitor. A smaller percentage (6%) of boys with haemophilia B develops inhibitors.

- The problems are seen in haemophilia changing as the treatment advances. Recombinant products will hopefully stop the transmission of viral infection and consequently the liver disease. Prophylaxis will reduce damage to joints with less painful chronic arthropathy and the need for replacement later in life. Home treatment allows a more normal life with less dependency on the haemophilia centre.

### DISSEMINATED INTRAVASCULAR COAGULATION CONSUMPTION COAGULOPATHY

Disseminated intravascular coagulation (DIC) is the commonest acquired haemostatic defect that occurs when there is *in vivo* activation of the coagulation mechanism resulting in an accelerated rate of conversion of fibrinogen to fibrin. Fibrin may or may not be deposited within blood vessels but resulting in disseminated microthrombi. It is always caused by some underlying disease process. Infection is the most common cause of DIC. Within this category bacterial septicaemia (gram negative bacterial infections) with associated septic shock is the most frequent infectious cause of DIC. Haemolytic uraemic syndrome, meningococcal septicaemia, falciparum malaria, haemolytic transfusion reactions and some snake venoms can induce a consumption coagulopathy. Virus-induced DIC occurs predominantly in immunocompromised patients. In children one of the most fulminant of DICs follows meningococcal septicaemia. Fungal infections are rarely a cause of DIC. Regardless of the underlying primary disease in the majority of patients the main clinical finding is bleeding and only a small number of patients will show thrombosis or thromboembolic episodes. Microthrombi formation can lead to the syndrome of *Purpura fulminans*, which is characterised by peripheral gangrene of fingers and toes (Fig. 15.14).



**Fig. 15.14:** A child with purpura fulminans who developed gangrene of both feet

## Diagnosis

The laboratory findings consist of thrombocytopenia, anaemia with red cell fragmentation on the blood film, prolonged PT, APTT and TCT, low fibrinogen and elevated FDPs or D-dimers.

## Treatment

The aim of treatment of DIC is to control bleeding and to eliminate the threat of fibrin deposition. The management objectives include control or removal of the underlying disease, replacement of depleted pro-coagulants with fresh frozen plasma (FFP), cryoprecipitate and platelets and in selected cases medical interruption of the consumptive process with anticoagulants and platelet inhibitor drugs. Virus-inactivated FFP and cryoprecipitate are now available. In the presence of peripheral gangrene protein-C concentrate may be beneficial. Also, the use of exchange transfusion in newborns and plasma exchange in older children has been reported to be beneficial in some cases.

### Case Study

A 6-month-old comatose infant presented with fever, convulsions and numerous petechiae and purpura covering nearly all his skin. The echymotic patches on his feet became necrotic and gangrenous. He had meningococcaemia and disseminated intravascular coagulation. He had purpura fulminans.

## ACUTE LEUKAEMIAS

In childhood, leukaemia is nearly always of the acute variety. On the basis of morphologic classifications, they are divided into acute lymphoblastic leukaemia (ALL) and acute non-lymphocytic leukaemia (ANLL) or acute myeloid leukaemia (AML) types.

Approximately 80–85% of acute leukaemias in children are ALL and 15–20% are due to AML. Chronic myeloid leukaemia and myelodysplasia are rare. The exact cause of leukaemia remains unknown although the list of risk factors associated with childhood ALL is substantial.

## Clinical Features

The most common symptoms and clinical findings reflect the underlying anaemia, thrombocytopenia and neutropenia that result from the failure of normal haematopoiesis. Therefore, the most common presenting features are rapidly progressive pallor and spontaneous haemorrhagic manifestations such as purpura, epistaxis and bleeding from the gums. These are associated with increasing weakness, breathlessness on exertion, malaise, anorexia and fever. In some cases, the onset takes the form of a

severe oropharyngeal inflammation and enlargement of the cervical lymph nodes which does not respond to antibiotics. In two-thirds of children with ALL the onset is with bone pains and half of these will have radiological bone changes. Arthralgia, secondary to leukaemic infiltration of joints may be difficult to differentiate from other non-malignant disorders such as juvenile idiopathic arthritis or osteomyelitis. Extramedullary leukaemic spread causes lymphadenopathy, hepatomegaly and splenomegaly. In some patients, however, the signs are confined to pallor and haemorrhage of variable severity and distribution. Infrequently jaundice may develop or there may be early evidence of involvement of the CNS. Ophthalmoscopy frequently reveals retinal haemorrhages.

However, clinicians should be aware of the fact that ALL may mimic a number of non-malignant conditions.

### Case Study

A 4-year-old boy presented being pale, toxic and ill looking with generalised bruising for 2 weeks. On examination he had no lymphadenitis. Liver and spleen were 3 cm and 6 cm respectively. He had no fundal haemorrhages and no soft neurologic signs. Haemoglobin was 4.6 g/dL, platelets  $4.2 \times 10^9/L$  and WBC  $600 \times 10^9/L$ . Blood film showed numerous lymphoblasts. Cerebrospinal fluid (CSF) cytospin, no leukaemic blasts and chest X-ray normal.

*Diagnosis:* Acute lymphoblastic leukaemia

## Blood Picture and Bone Marrow Findings

In addition to severe anaemia the peripheral blood films will show immature cells. These are most often lymphoblasts, less commonly myeloblasts and other granulocytic precursors, rarely monoblasts or neoplastic megaloblastic erythroid cells. The total WBC is often raised to between 20,000 and 30,000/mm<sup>3</sup>; only rarely to a very high figure. Thrombocytopenia is almost invariably found. Reticulocytes are usually scanty. It is, however, rarely justifiable to base the diagnosis of leukaemia on the peripheral blood picture alone. Bone-marrow biopsy will nearly always confirm the diagnosis beyond doubt, the films and sections showing gross leukaemic infiltration by immature or abnormal white cell precursors, diminution in erythropoietic activity and disappearance of megakaryocytes.

The majority of children presenting with ALL will have more than 80% of their marrow cells consisting of lymphoblasts, whereas it is not uncommon to see the presence of only 30–50% blasts in the bone marrow in ALL. The majority of childhood acute leukaemias (85–90%) can be readily separated into lymphoid or myeloid (Figs 15.15 and 15.16) subtypes on the basis of morphology alone. Thus, although in most cases the diagnosis is apparent from the

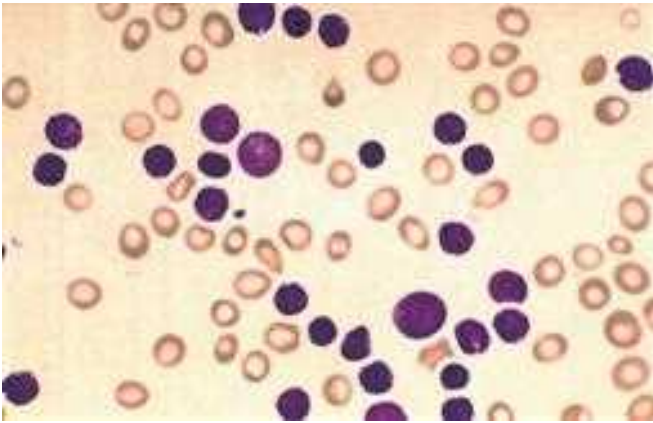


Fig. 15.15: Photomicrograph of bone marrow of a child with ALL

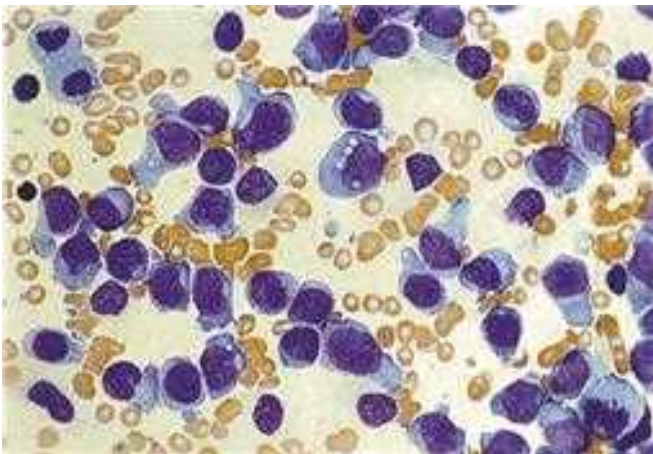


Fig. 15.16: Photomicrograph of bone marrow of a child with acute myeloid leukaemia showing myeloblasts

morphology, the final diagnosis of ALL rests on confirmatory cytochemical staining patterns, immunophenotype and cytogenetic studies. These studies are of therapeutic significance in lymphatic leukaemias.

## MENINGEAL AND TESTICULAR LEUKAEMIA

Meningeal and testicular leukaemia became a major problem when the duration of life for children with acute leukaemia progressively lengthened as the result of treatment with modern anti-leukaemic drugs. This manifestation commonly develops in patients who are in complete haematological remission and the incidence has exceeded 50% in some series. Not infrequently the meningeal relapse coincides with a systemic relapse. It is probable that a few nests of leukaemic cells are already present when the patient first presents and as the cytotoxic drugs do not readily cross the blood-brain-barrier (BBB) these neoplastic cells are able to multiply in the largely protected environment of the

brain and meninges. The child, who has been in systemic remission for months or even some years, develops headache, vomiting and meningism. A rapid increase in weight due to the increased appetite because of hypothalamic damage is not uncommon. There may be neurological signs such as squint, ataxia, or visual disturbance, but more often the only signs are of increased intracranial pressure (ICP) including papilloedema. Cerebrospinal fluid (CSF) will show a pleocytosis due to leukaemic blast cells with increased protein and reduced glucose. The recent introduction of cranial or craniospinal radiation combined with intrathecal methotrexate has drastically reduced the incidence of meningeal relapses.

## Testicular

The testes are a major site of extramedullary relapse in boys with ALL. Clinically, overt testicular relapse presents as painless testicular enlargement that is usually unilateral.

## Prognostic Factors

Prognostic factors may be influenced by the treatment given:

- WBC and age are important prognostic indicators and are used to stratify treatment. Children with a WBC more than  $50 \times 10^9/L$  and those more than 10 years of age have a less favourable outcome than those who are younger with a lower WBC. Infants less than 1 year of age have a particularly poor outlook.
- Girls have a more favourable prognosis than boys.
- *Immunophenotype*

Common ALL or B-lineage disease does better than T-cell ALL. Mature B-cell ALL is more characteristic of a Burkitt type lymphoma than a leukaemia and is treated as such.

### *Cytogenetics*

Hyperdiploidy and t(12,21) are favourable; near haplo-diploid, t(9,22) and t(4,11) are poor prognostic indicators. AML 1 amplification also appears to be associated with a poor outlook.

## Management

### *Supportive Care*

Children should receive adequate intravenous hydration and allopurinol prior to commencing therapy. They may require red cell and platelet support to correct anaemia and thrombocytopenia and antibiotics for febrile neutropenia.

## Chemotherapy

The outlook for standard-risk ALL is now at least 70–80% and this is achieved with combination intensive chemotherapy.

The rate of cell kill is a vital prognostic indicator (the faster the disease clears the better the outcome).

## Treatment

Treatment of acute lymphoblastic leukaemia is arbitrarily divided into the following

### Induction Therapy

This refers to the initial weeks of treatment, which aims to eradicate disease from the bone marrow and allow it to repopulate with normal cells. Children are stratified by their age (< 10 years) and by WBC (< 50x10<sup>9</sup>/l) to the intensity of their induction therapy. The combination of dexamethasone (superior to prednisolone because of better control of CNS disease), vincristine and asparaginase ± daunorubicin, depending on the child's age and WBC results in remission in at least 95% of children.

*Intensification/Consolidation:* The intensity is tailored to the prognostic group. Combination chemotherapy is used to prevent development of drug resistance.

*Central nervous system-directed treatment:* Central nervous system-directed therapy is important in reducing the risk of CNS relapse, although dexamethasone and intensive chemotherapy contribute. Intrathecal methotrexate, high-dose systemic methotrexate and cranial radiation have been employed. Cranial radiation is now reserved for the treatment of CNS leukaemia because of its associated neuropsychological impairment and learning difficulties. Intrathecal methotrexate is currently used in the UK.

*Maintenance/Continuing Chemotherapy:* This involves daily 6-mercaptopurine, weekly methotrexate and 4 weekly vincristine and dexamethasone. Currently in the UK, boys receive treatment for 3 and girls for 2 years.

Co-trimoxazole (Septrin) is given throughout as prophylaxis against *Pneumocystis carinii pneumonia* (PCP).

## Acute Myeloid Leukaemia

The presenting signs and symptoms in this type of leukaemia are similar to those seen in children with ALL. FAB M4–M5 subtype manifest with extramedullary disease, including infiltration of gum and skin, lymphadenitis and CNS involvement. Sometimes, there are rare features such as chloromas, which are solid masses of myeloblasts which can develop around the orbits, spinal cord or cranium.

Investigations are similar to those for ALL. The myeloblasts usually contain Auer rods and these are seen only in AML.

## Treatment

About 90% of children with AML achieve remission with one or two courses of intensive combination chemotherapy. Usually a total of four blocks of treatment are required. Allogenic bone marrow transplantation is reserved for those children in whom response to chemotherapy is slow. The disease free survival is now in the region of 60%.

## Stem Cell Transplantation

Stem cells are primal undifferentiated cells which retain the ability to differentiate into other cell types. This unique ability allows the stem cells to act as a repair system for the body and replenishing other cells as long as the organism is alive, thus change the face of human disease.

The sources of stem cells are bone marrow, blood from placenta and umbilical cord. Stem cell transplantation may be defined as autologous (recipients own stem cells), syngeneic (twins stem cells) or allogenic (stem cells from sibling, non-sibling related or unrelated donor).

Allogenic treatment stem cell transplantation is generally employed in leukaemia and primary bone marrow disorders. Stem cell transplantation has also been used in Hunter syndrome, Hurler syndrome, thalassaemia major, sickle cell disease, immunodeficiency/inborn errors of metabolism.

## Langerhans Cell Histiocytosis

The term Langerhans cell histiocytosis is used to include the conditions previously called eosinophilic granuloma (single or multiple), Hand-Schueller-Christian triad (diabetes insipidus, exophthalmos and large defects in the membranous bones of the skull) and Letterer-Siwe disease. These are not malignancies. They present in a wide variety of ways from non-specific aches and pains to specific lytic bone lesions, to wide spread lymphadenopathy, hepatosplenomegaly and skin rash. Chronic otitis media, diabetes insipidus and weight loss are common in some types.

The old term "histiocytosis x" has been modified into a form of staging system:

Stage 1: Single lytic bone lesion;

Stage 2: Multiple lytic bone lesions (both previously called eosinophilic granulomata);

Stage 3A: Bone plus soft tissue lesions, often associated with diabetes insipidus or exophthalmos (previously termed Hand-Schuller-Christian triad);

Stage 3B: Soft tissue only, disseminated form (previously termed Letterer-Siwe disease).

The groups are not exclusive and overlap may occur. Stage 3B disease (Letterer-Siwe disease) mostly seen in young infants. They often have wasting, adenopathy, hepatosplenomegaly, anaemia and pancytopenia with red to

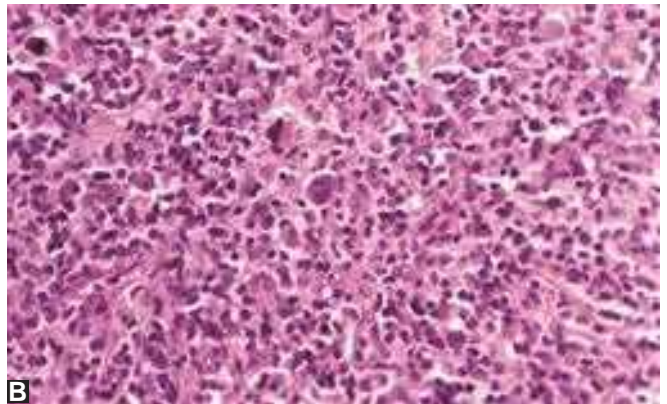


**Fig.15.17:** Purpuric rash in Letterer-Siwe disease

purple skin rashes, seborrhoeic dermatitis and multiple organ involvement (Fig. 15.17). In most cases of Langerhans cell histiocytosis the disease appears to be self-limiting so that minimal intervention is required except where the disease is clearly progressing.

### Hodgkin's Disease (Hodgkin's Lymphoma)

Hodgkin's disease can affect children at any age but is common in teenagers and young adults. Children with Hodgkin's disease present with asymptomatic lymph node enlargement, most commonly in the neck. The lymph nodes appear to be firm and rubbery on palpation. In some cases, respiratory symptoms manifest due to tracheal or bronchial compression or facial oedema and congestion due to pressure on the superior mediastinal great veins, or dyspnoea and wheeze. Involvement of pleura or pericardium may worsen the chest symptoms. In other cases hepatosplenomegaly, jaundice and ascites appear. As the disease progresses increasing anaemia, leucopaenia and thrombocytopenia may occur. Eosinophilia in the peripheral blood is rare. Also, fever, weight loss, night sweats are associated with advanced disease. The presence of constitutional symptoms, including unexplained fever more than 38°C, night sweats or weight loss of more than 10% of body weight, these three symptoms are classified as B symptoms and they are used in staging to indicate adverse prognosis. If the child has none of these symptoms the lymphoma will be classified as A. Biopsy of enlarged lymph nodes is diagnostic (Figs 15.18A and B).



**Figs 15.18A and B:** A 6-year-old boy with Hodgkin's disease presented with left cervical lymphadenopathy (stage 1 A disease). (B) Photomicrograph of lymph node biopsy showing Reed-Sternberg cells with two nuclei

The recording of disease extent using the staging criteria is essential and is based on the assumption that spread is from contiguous node to node. The disease extent is defined as "stage of disease". Patients with different disease stage at presentation have different prognosis, regardless of the ensuing course of disease. Therefore, CT or MRI scanning of the chest and abdomen should be carried out to ascertain the degree of mediastinal involvement and for the assessment of hepatic, splenic and abdominal nodal disease.

The staging classification for Hodgkin's disease is as follows:

- Stage I: Involvement of a single lymph node region of lymphoid structure or involvement of a single extra-lymphatic site.
- Stage II: Involvement of two or more lymph node regions on the same side of the diaphragm.

- Stage III: Involves lymph node regions on both sides of the diaphragm. Also accompanied by involvement of spleen or localized contiguous involvement of only one extranodal organ site or both.
- Stage IV: The lymphoma has spread beyond the lymph nodes, e.g. liver, lungs or bone marrow.

### Treatment

The management consists of field radiotherapy and multiagent chemotherapy. Multiple drug combinations

such as ABVD–doxorubicin (previously Adriamycin), bleomycin, vinblastin and dacarbazine, is a commonly used combination for Hodgkin's disease. It is given intravenously. Procarbazine is most often used in Hodgkin's disease. It is given orally. It is a weak monoamine-oxidase inhibitor and dietary restriction is rarely considered necessary. Blood transfusion may be required for the correction of progressive anaemia. The cure rate for children has steadily improved with the introduction of combined radiation and multiagent chemotherapy.

# Paediatric Rheumatology

## INTRODUCTION

As most causes of recent onset arthritis are usually the result of trauma or infection, these children fall into the care of the orthopaedic surgeon. Whilst there is considerable overlap the paediatrician tends to be involved in managing those children with chronic joint pains and arthritis, many of whom have a common condition, some being quite rare. The aim of this chapter is to discuss the clinical manifestations and management of the more common conditions dealt with by the paediatrician.

## CAUSES OF ARTHRALGIA AND ARTHRITIS IN CHILDREN

The causes of arthritis in children are multiple and it is important to remember that many children presenting with joint pains do not have arthritis. The initial assessment of the child should include the following questions:

### Onset Before or After 6 Weeks

Whilst most cases of trauma and reactive arthritis improve within 1 month of onset, most autoinflammatory conditions such as juvenile idiopathic arthritis (JIA) persist for much longer.

### Single or Multiple Joint Involvements

Single joint involvement is much more likely to signify a local condition such as trauma, sepsis or avascular necrosis as in Perthe's disease and osteochondritis dissecans.

### Episodic, Continuous, Flitting or Recruiting

Trauma and hypermobility are mostly associated with episodic pain whilst autoinflammatory conditions such as JIA cause continuing symptoms and recruit new joints. Flitting joint pains are characteristic of rheumatic fever.

## Associated Manifestations

The typical rashes in Henoch-Schönlein purpura (HSP), systemic lupus erythematosus (SLE), dermatomyositis are usually diagnostic. Fever frequently accompanies viral infections but the persistent daily spike of fever in systemic-onset JIA helps to distinguish this condition from viral infections. In nonorganic joint pains there are usually no associated findings.

Differential diagnosis of arthralgia and arthritis in children is given in Table 16.1.

## JUVENILE IDIOPATHIC ARTHRITIS

### Subtypes of Juvenile Idiopathic Arthritis

The term JIA was first proposed by the International League Against Rheumatism (ILAR) in 1997 to describe the different subtypes of arthritis and to distinguish chronic inflammatory arthritis in children from adult rheumatoid arthritis (RA). Although the condition is known to have an autoimmune and autoinflammatory origin its exact aetiology remains unknown. No triggering agent has ever been identified but an autoimmune family background is frequently present, in particular diabetes, RA and thyroid disease. However, sibling pairs with JIA are unusual. The autoimmune dysfunctions result in a markedly increased production of intra-articular inflammatory cytokines leading to inflammation and hypertrophy of the synovial lining with production of excess intra-articular fluid and erosion of the cartilage and ultimately bone by the hypertrophied synovium. The following JIA subtypes are included in the latest classification:

- Oligoarthritis—Involvement of up to four joints (usually large ones)
- Extended oligoarthritis—Extension to five or more joints after 6 months from presentation
- Polyarthritis, rheumatoid factor (RF) negative—5+ joints (large or small) involved at presentation

**Table 16.1:** Differential diagnosis of arthralgia and arthritis in children

<i>Recent onset less than 6 weeks duration</i>		
<i>Single joint:</i>		
Trauma:		Accidental and nonaccidental Slipped upper femoral epiphysis
Infection:		Septic arthritis/Osteomyelitis Transient synovitis/Reactive arthritis
<i>Multiple joints:</i>		
Reactive arthritis:		Streptococcal, mycoplasma, enterovirus and EBV
Vasculitis:		Henoch-Schönlein purpura Kawasaki disease
Malignancy:		Leukaemia, neuroblastoma
<b>Onset of chronic arthritis</b>		
<i>Chronic arthralgia/arthritis more than 6 weeks duration</i>		
Joint hypermobility:		Benign joint hypermobility syndrome (BJHS) Ehlers-Danlos syndrome
Auto-inflammatory:		Juvenile idiopathic arthritis
Connective tissue disease:		SLE, scleroderma, mixed connective tissue disease (MCTD) Juvenile dermatomyositis (JDM)
Infection:		Reactive arthritis Lyme disease Tuberculous arthritis
Apophysitis:		Osgood-Schlatters disease, Sever's disease, etc.
Avascular necrosis:		Perthes disease Osteochondritis dissecans
Vasculitis:		Polyarteritis nodosa, Wegeners granulomatosis
Malignancy:		Leukaemia, metastatic and primary bone tumours
Nonorganic:		Stress, anxiety related

- Polyarthritis, RF positive—Paediatric equivalent of adult RA
- Psoriatic arthritis—Other features of psoriasis or first degree relative with psoriasis
- Systemic onset arthritis—Fever and rash at presentation, arthritis starting later
- Enthesitis related arthritis (ERA)—Human leukocyte antigen (HLA) B27 positive paediatric equivalent of adult ankylosing spondylitis
- Other chronic arthritides including arthritis in Down's syndrome and other chromosomal abnormalities and inflammatory bowel disease.

### Oligoarticular Juvenile Idiopathic Arthritis

Oligoarticular JIA is the most frequent type of arthritis in children in North America and Europe. On the contrary,

systemic JIA and polyarticular JIA predominate in most parts of Asia including Japan, China and India. Oligoarticular JIA occurs predominantly in young girls less than 4 years old. It is defined as persistent oligoarthritis affecting four or fewer joints during and after the first 6 months of disease. It carries a 30% risk of uveitis especially in antinuclear factor (ANF) positive children (Fig. 16.1). Extended oligoarticular JIA is diagnosed when a child presenting with oligoarthritis continues to recruit new joints 6 months or more after disease onset. The arthritis extends to both large and small joints, becoming more aggressive and resistant to therapy. It carries a bigger risk of uveitis (40%) than oligoarthritis. The knee and then the ankle are the two most commonly involved joints (Figs 16.2A and B). Oligoarthritis carries the best prognosis for remission though its course is often prolonged. The prognosis is worse for extended oligoarthritis.





**Fig. 16.1:** Oligoarticular JIA—showing synechiae, irregular pupil and complicated cataract as a result of prolonged chronic iridocyclitis

### **Polyarticular Juvenile Idiopathic Arthritis (Rheumatoid Factor Negative, Rheumatoid Factor Positive)**

Children with polyarticular JIA have five or more affected joints from outset. Both small and large joints are involved with typically the proximal interphalangeal (PIP) joints of the fingers being affected. They do not usually have any systemic manifestations. Whilst most cases are RF negative about 5% are RF positive. These tend to be girls of about 10 years of age or more and have a more aggressive course of arthritis than RF negative cases. They are the paediatric equivalent of adult RA. The risk of uveitis in RF negative cases is about 10%. Uveitis is very unlikely in RF positive cases. The chance of remission decreases as the number of involved joints increases. RF positive cases are lifelong.

### **Systemic Onset Juvenile Idiopathic Arthritis (Still's Disease)**

The major signs and symptoms of this subtype of JIA are systemic. The most common age of onset of the disease is under 5 years, but it can occur throughout childhood. Boys are affected as frequently as girls. Characteristic features are high remittent fever and a rash, generalised lymphadenopathy, splenomegaly and polymorphonuclear leucocytosis. The rash has an irregular outline and is coppery red in colour. It is sometimes pruritic and never purpuric (Fig. 16.3). The best time to look for the rash is just after the child has had a hot bath or at the height of the temperature elevation. The fever shows diurnal swings as large as 2°C or 3°C which are rarely seen in acute rheumatic fever (ARF). Acute pericarditis is an uncommon manifestation. Endocardial involvement is extremely rare. Joint manifestations are usually present at an early stage although they may initially amount to arthralgia without visible swelling. Large joints are more commonly



**A**



**B**

**Figs 16.2A and B:** Oligoarticular JIA: (A) Swelling of both knees; (B) Swelling of right ankle

involved than small joints. Uveitis is unusual. Some children run a monophasic course with the disease remitting after 2–3 years, but frequently the course is chronic and relapsing, with widespread joint involvement and persistent rash. Laboratory findings include anaemia, leucocytosis, an elevated erythrocyte sedimentation rate (ESR) and C-reactive protein (CRP). Gross elevation of the ferritin level can be a marker for the condition. The anti-nuclear antibody (ANA) is rarely positive. Macrophage activation syndrome is a rare but life-threatening complication of systemic JIA. The major clinical manifestations of macrophage activation syndrome are non-remitting fever, hepatosplenomegaly, lymphadenopathy, bleeding diathesis, altered mental status and rash and



**Fig. 16.3:** Rheumatoid rash—characterised by salmon pink macules, usually coming and going with the fever spikes

may mimic a flare-up of systemic-onset JIA. The typical laboratory findings are leucopenia and thrombocytopenia. A high index of suspicion is required. Early diagnosis and prompt treatment can be life-saving.

### Juvenile Psoriatic Arthritis

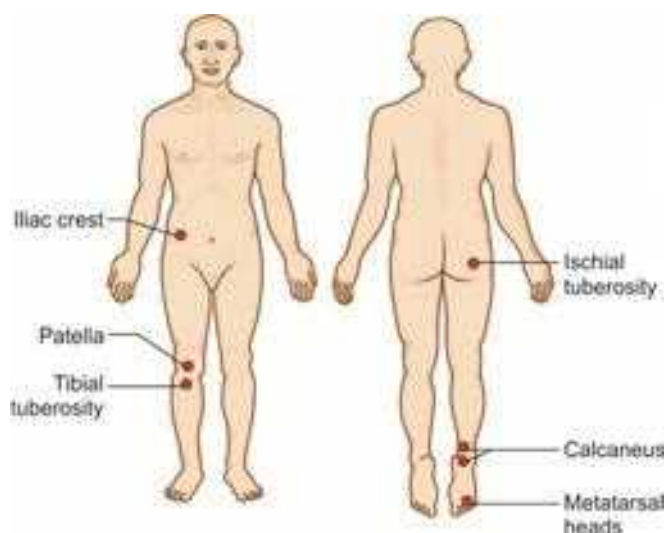
Arthritis is frequently the initial manifestation of psoriasis in children and should be suspected when there is a family history of psoriasis especially if it affects one of the parents. It is similar to polyarthritis frequently affecting several small and large joints and typically involving both PIP and distal interphalangeal (DIP) joints resulting in a sausage-like swelling of the whole affected digit called dactylitis (Fig. 16.4). In over 50% of cases, skin manifestations appear after the onset of arthritis but close inspection of the fingernails sometimes shows the typical nail changes associated with psoriasis including pitting, horizontal ridging or onycholysis. The risk of uveitis in psoriatic arthritis is minimal. Psoriatic arthritis is an inherited disorder and therefore lifelong.

### Enthesitis Related Arthritis

Enthesitis related arthritis is the paediatric equivalent of adult ankylosing spondylitis. It frequently presents with inflammation of the enthesis at the site of insertion of tendons and fasciae into bone (Fig. 16.5). These sites become inflamed, painful and tender, which makes ERA the most painful arthritis of all the JIA subgroups. The arthritis tends to affect mainly the lower limb joints frequently presenting with painful feet due to a combination of arthritis and plantar fasciitis. Hips and knees are commonly affected. Back pain in children tends to be due to sacroiliitis. Axial involvement



**Fig. 16.4:** Psoriatic arthritis—dactylitis of the second toe



**Fig. 16.5:** Enthesopathic sites in children with enthesitis related arthritis

does not usually manifest itself in the paediatric age group. Ocular involvement is caused by acute uveitis and patients present with a painful red eye. Most children with ERA are HLA-B27 positive and ANA and RF negative.

### Other Inflammatory Arthritides

Inflammatory arthritis is associated with several other conditions such as Down's syndrome and other chromosomal abnormalities. Inflammatory bowel disease is frequently associated with arthritis of both peripheral and axial skeleton, the severity of the arthritis tending to reflect the degree of bowel inflammation and improving when the bowel disease is brought under control.

**Key Learning Points**

- Juvenile idiopathic arthritis is different from adult RA.
- Children with JIA often have joint stiffness but little pain.
- Enthesitis related arthritis is the most painful type of JIA.
- The prognosis for remission in JIA becomes worse with increasing joint involvement.
- The risk of uveitis diminishes with increasing joint involvement.
- All cases of JIA should be screened for uveitis at presentation.
- Uveitis screening should continue for at least 7 years after disease onset.
- Systemic manifestations in systemic-onset JIA frequently precede arthritis.

**TREATMENT OF JUVENILE IDIOPATHIC ARTHRITIS**

It is important to suppress the intra-articular inflammation before joints are permanently damaged. JIA should be suspected early in any child presenting with 6-week history or longer of morning stiffness and joint pains particularly if evidence of joint inflammation is present on examination. There is no laboratory test for JIA. Diagnosis is made on clinical grounds. Ideally treatment should start within 3 months from onset aiming at controlling the disease by 6 months from onset. To achieve this it is best to start therapy with multiple pharmacological agents and taper down according to response.

**Corticosteroids**

The fastest way to suppress intra-articular inflammation is by the injection of a suitable steroid preparation into the joint. Triamcinolone hexacetonide is currently the most effective steroid for intra-articular use. Injections may need to be repeated according to response and recurrence rate. In oligoarthritis a steroid injection may be enough to control arthritis for several weeks and months. In children presenting with polyarthritis a rapid improvement can be achieved by the administration of intravenous methylprednisolone in pulses at presentation and over the following few weeks. Any residually inflamed joints are then injected with steroid. Oral steroids like prednisolone have significant side-effect when used long-term and are best reserved for short-term use (< 1 month) to control flare-ups until other medications take effect.

**Nonsteroidal Anti-Inflammatory Drugs**

Nonsteroidal anti-inflammatory drugs (NSAIDs) reduce the production of prostaglandins by inhibiting the enzyme cyclooxygenase. Since they are not disease-modifying drugs they are mainly used to treat pain, stiffness and fever. Differences in anti-inflammatory activity between different NSAIDs are

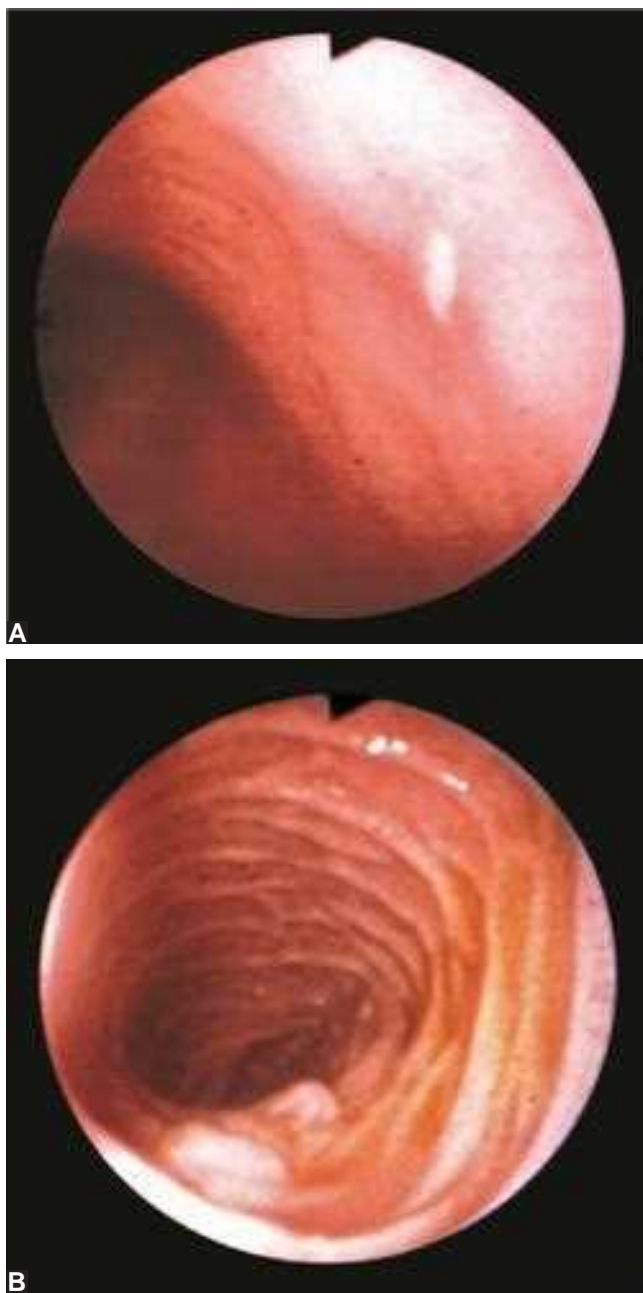
small, but there is considerable variation in individual patient tolerance and response. A large proportion of children will respond to any NSAID; of the others, those who do not respond to one may well respond to another.

In JIA, NSAIDs may take 4–12 weeks to manifest their anti-inflammatory effect. However, pain relief starts soon after taking the first dose and a full analgesic effect should normally be obtained within a week. If appropriate responses are not obtained within these times another NSAID should be tried. In children serious gastrointestinal (GI) side-effects are rare although gastritis and gastroduodenal ulcer with perforation and bleeding have been reported (Figs 16.6A and B). As children appear to tolerate NSAIDs better than adults the use of gastroprotective drugs such as ranitidine and omeprazole may not be routinely used.

Ibuprofen combines anti-inflammatory, analgesic and antipyretic properties. It has fewer side-effects than other NSAIDs, but its anti-inflammatory properties are weaker. Piroxicam combines good efficacy with a low incidence of side-effects and a once daily regimen.

**Synthetic Disease-Modifying Anti-rheumatic Drugs***Methotrexate*

The use of methotrexate to suppress the underlying immune abnormality in JIA revolutionised the treatment of this condition in the 1990's. Given in a dosage of 0.3–0.7 mg/kg per week it is slow acting with the first benefits noticeable after 1 month of therapy and maximum efficacy achieved after 3 months. Common side-effects include nausea and vomiting which may cause difficulty with compliance. Changing oral administration to the subcutaneous route helps reduce this side-effect at the same time increasing the bioavailability of the drug. The administration of folic acid supplements 24–48 hours after administering methotrexate may help to reduce GI side-effects. Liver toxicity is the next most common side-effect and methotrexate therapy needs to be monitored with regular checking of liver function tests (LFTs), initially monthly for the first 6 months. If it is well tolerated this can be reduced to 3 months subsequently. Less frequently methotrexate may induce neutropenia so that the blood picture and white cell count should be checked at the same time as the liver function. The administration of live vaccines is contraindicated during methotrexate therapy. It is useful to establish whether the patient is varicella immune before the start of therapy as chickenpox infection can be quite severe during methotrexate therapy. If a susceptible person is in contact with chickenpox the chances of infection can be minimised by the administration of zoster immune globulin (ZIG) within 48 hours of contact. In established infection intravenous acyclovir given as soon as the first vesicles appear helps to minimise the severity of infection.



**Figs 16.6A and B:** Upper GI endoscopy: (A) Showing antral erosion secondary to NSAIDs; (B) Duodenitis secondary to NSAIDs

### *Sulphasalazine*

Sulphasalazine use has been superseded by methotrexate, but it is useful in the management of ERA when methotrexate is not tolerated. It is started at a dose of 50 mg/kg per day in two doses increasing at weekly intervals to a maximum of 2,000 mg daily. Monitoring of full blood count (FBC) and LFT is recommended before each dose increase and should

continue at 3 monthly intervals once maximum dosage is achieved.

### *Cyclosporin A*

The use of cyclosporin is mainly limited to the treatment of systemic-onset JIA which responds less well to methotrexate even after the initial rapid control of the condition with steroid therapy. Cyclosporin therapy can be associated with deteriorating renal function and hypertension and frequent monitoring of renal function and blood pressure is recommended until the therapeutic dose is established. Dosage varies between 3–7 mg/kg per day orally or IV depending on response.

### **Biological Disease-Modifying Anti-rheumatic Drugs (Biological Agents)**

Biological agents are monoclonal antibodies capable of blocking specific inflammatory cytokines and switching off the autoimmune response. Etanercept is a tumour necrosis factor (TNF)-blocking agent, first appeared on the market in 1999 and has been followed by a rapid succession of other agents. It achieved better control of JIA when response to synthetic disease-modifying anti-rheumatic drugs (DMARDs) was poor. Even better results are obtained when the two are combined. It was followed by infliximab, also a TNF blocker, which is particularly effective in the management of JIA associated chronic anterior uveitis. Later adalimumab became available. It is TNF blocker with the advantage of needing administration only once every 2 weeks. Anakinra is an IL1 blocker and seems to be particularly effective in the management of systemic-onset JIA. Tocilizumab is an IL6 blocker also useful in controlling systemic-onset JIA.

Rituximab depletes B cells and has some use in managing cases of systemic-onset JIA which have not responded to other therapies. Abetacept is a T cell modulator useful in managing difficult cases of polyarticular JIA. A number of other biological agents are awaiting clinical evaluation.

All biological agents available so far need to be administered parenterally in various dosage regimens. Indications for their use have to be carefully assessed per individual patient, particularly because significant potential side-effects and the considerable cost involved in prescribing them.

#### **Key Learning Points**

- Early diagnosis of JIA is important to diminish joint damage.
- Juvenile idiopathic arthritis becomes increasingly resistant to treatment with delay in start of therapy.
- Intra-articular steroid injection is a rapid way of reducing joint inflammation.

### Juvenile Idiopathic Arthritis Associated Uveitis

Uveitis is the inflammation of the internal lining of the eye. It frequently starts at the same time as the onset of arthritis, but sometimes follows arthritis onset by months and years. Occasionally it presents before the onset of JIA. It is more common in girls especially if they are ANA positive and the risk of developing uveitis is inversely proportional to the number of joints involved. Every child presenting with JIA should have uveitis screening at presentation and this has to be continued subsequently at 3–6 monthly intervals until the child reaches 12 years of age. Any delay in detection of uveitis allows complications such as synechiae, cataract, raised intraocular pressure and band keratopathy to develop. Prolonged therapy with ocular steroid drops increases the risk of cataract and glaucoma and should be replaced by systemic therapy ideally within 3 months. Methotrexate is very effective in controlling uveitis. In more resistant cases, the addition of infliximab or adalimumab usually achieves control. Poorly controlled uveitis leads to irreversible and permanent blindness.

#### Key Learning Point

- ➔ Screening for JIA associated uveitis should start at first consultation and continue 4–6 monthly for up to 8 years or until 12 years of age.

### PHYSIOTHERAPY AND OCCUPATIONAL THERAPY

Physiotherapy and occupational therapy are important adjuncts to medication because they help maintain and improve range of motion of joints, muscle strength and skills for daily living activities. Exercises may be performed in the warm water of the hydrotherapy pool.

A physiotherapist should plan an exercise programme tailored to the child's needs. The role of an occupational therapist is to keep the child as independent as possible. The occupational therapist assesses any difficulties caused by the arthritis and advises the child, parents, schoolteachers and other carers on ways of helping with these difficulties, e.g. using specially adapted cutlery and pencil grips.

### Surgical Treatment

Most cases of JIA do not require surgery. However, some children may need total hip replacement or knee arthroplasty. Every attempt should be made to delay surgery until skeletal maturity if possible.

### JUVENILE REACTIVE ARTHRITIS

Reactive arthritis occurs when inflammation of the synovium is triggered in response to infection outside the joint. The exact

mechanism is not understood but is thought to be an auto-immune response, frequently associated with certain viral infections (such as enterovirus, parvovirus B19, EB virus and rubella) and bacterial infections, typically streptococcal and mycoplasma. Several enteropathic infections are frequently followed by reactive arthritis including *Salmonella* species, *Shigella flexneri* and *Campylobacter*. In many cases of reactive arthritis no etiological agent is identified. The child frequently presents with acute painful swelling of one or both knees having been well the previous day. Other joint may be involved. The condition settles within a few weeks and does not usually persist longer than 1 month, hence the importance of the initial 6-week monitoring period before diagnosing JIA which persists longer and frequently continues to recruit new joints.

### Post-Streptococcal Reactive Arthritis

Children with sustained fever, arthritis, raised CRP/ESR and a preceding group A, C, or G streptococcal infection who do not fulfil the 1992 Jones criteria of ARF may be diagnosed as having post-streptococcal reactive arthritis. The arthritis is symmetrical and prolonged in character; knee and ankle joints are regularly involved but small joints and axial involvement also occurs. It has been suggested that ARF and post-streptococcal reactive arthritis are separate disease entities. Therefore, a routine long-term antibiotic prophylaxis is not recommended.

### Juvenile Reiter Syndrome

Reiter syndrome with the typical triad of urethritis, arthritis and conjunctivitis is rare in children. The most common cause of this syndrome in childhood is infective diarrhoea, due to *Shigella* or *Salmonella* or other enteric pathogens. The knee is the most commonly involved joint but ankles and single toes or fingers can be affected (Fig. 16.7). Diagnosis of Reiter syndrome is primarily clinical. The prognosis is usually good with gradual amelioration of signs and symptoms.

### Lyme Disease

In 1977 Steer and his colleagues announced the discovery of a new disease called Lyme disease which they proved transmitted by the deer tick *Ixodes dammini*. The ticks may be carried on the bodies of birds, pets, wild animals or people. In 1982 it was discovered that infectious agent is a spirochaete (*Borrelia burgdorferi*). The clinical syndrome consists of an initial febrile illness associated with a characteristic rash, erythema chronicum migrans, headache, aseptic meningitis, Bell's palsy and vague joint and muscle pains. Left untreated recurrent episodes of arthritis involving mainly large joints occur, lasting a few weeks at a time with symptom free intervals in between. The initial phase of the



**Fig. 16.7:** Reiter syndrome—dactylitis of third right finger

disease may be mild and forgotten so that arthritis may be the initial manifestation of Lyme disease. The diagnosis should be confirmed with Lyme serology (ELISA and immunoblot assays). Lyme disease should generally be treated with amoxicillin or doxycycline. Doxycycline should only be used in children over 12 years of age. Also intravenous administration of cefotaxime, ceftriaxone or benzylpenicillin is recommended for 2–4 weeks, when Lyme disease is associated with cardiac or neurological complications.

### Arthropathy in Inflammatory Bowel Disease

Arthritis is the most common extraintestinal manifestation of inflammatory bowel disease occurring in both Crohn's disease and ulcerative colitis. It predominantly affects large joints, especially the knees and ankles, but axial involvement (spondyloarthropathy) has been reported especially in patients who are HLA-B27 positive. The onset of arthritis usually follows the onset of bowel disease but may precede it by months or years. The arthritis tends to reflect the state of bowel inflammation and can be difficult to control until the bowel inflammation settles. Axial involvement tends to run an independent course from bowel inflammation.

### BENIGN JOINT HYPERMOBILITY SYNDROME

Generalised joint laxity is a feature of the hereditary connective tissue disorders such as Marfan's syndrome, Ehlers-Danlos syndrome and osteogenesis imperfecta. However, hypermobility without other associations is common in the general population. Hypermobility denotes the ability to move joints through a bigger range than normal. Whilst in many children this is asymptomatic, in

some it is associated with joint pains particularly in the lower limbs. This condition is called BJHS. The pains typically come on during or immediately after exercise, causing the child to stop and ask to be lifted. They occur mostly in the evenings sometimes waking the child up during the night. They frequently are related to the amount of activity the child performs during daytime. Hypermobile children are frequently described as being clumsy, frequently tripping and falling and being accident prone and have been shown to have poor proprioception. Assessment of the degree of hypermobility includes assessment of the Beighton score. One point is awarded for each of the following:

- Ability to hyperabduct the thumbs to touch the forearm: 2 points
- Ability to extend the small finger beyond 90 degrees: 2 points
- Hyperextension of both knees: 2 points
- Hyperextension of elbows beyond 190 degrees: 2 points
- Ability to touch floor with palms while keeping knees straight: 1 point

A score of 6 or more indicates generalised hypermobility. In some children hypermobility may be localised to only a few joints with symptoms occurring only in affected joints.

Treatment includes reassurance of parents and child that the pains are not caused by arthritis and that in many cases both hypermobility and joint pains improve by the time the child reaches puberty. Children with BJHS tend to avoid exercise due to the associated pain, only to experience even more pain because of wasting of their muscles. Physiotherapy is the mainstay of therapy by keeping muscle in good shape. Occupational therapy helps with posture, positioning and hand function. Pes planus is common in children with BJHS. The supply of corrective insoles is sometimes of benefit in keeping the foot in a normal position and reducing pain in knees and ankles.

#### Key Learning Points

- Benign joint hypermobility syndrome is a common cause of joint pain in children.
- Pain occurs during exercise and later on in the day.
- Nocturnal pain in the legs frequently occurs.
- About 50% of children continue to have joint pains in adult life.

### LIMB PAINS OF CHILDHOOD WITH NO ORGANIC DISEASE (IDIOPATHIC LIMB PAINS)

Growing pains in children occur during the growing the years of rapid growth between 3 and 10 years of age. The child typically wakes up during the night complaining of severe pain in the lower limbs especially in the legs and knees, without any obvious visible abnormality. Rubbing of the affected area together with simple analgesia helps. The

child goes back to sleep after 30–60 minutes, waking up in the morning perfectly well. In most cases, no cause for these pains can be identified. The parents need to be reassured that these pains are common and harmless. In some cases, similar night pain occurs in association with BJHS. Other causes of night pain to be included in the differential diagnosis include bone pain secondary to leukaemia, bony metastasis from a neuroblastoma and more rarely, a bone tumour. In these cases, however, some pain occurs during the daytime and/or may be felt in parts of the body other than the lower limbs.

In older children, particularly in adolescents, may be a manifestation of anxiety and stress and not necessarily associated with organic pathology. Pain is usually far in excess of clinical manifestations and when careful examination and investigation fail to identify any abnormality, psychogenic causes for arthralgia should be considered and the opinion of a child psychologist should be sought.

#### Case Study

A 10-year-old girl presented with nocturnal lower limb pains for 6 months. At no time did she have swelling or tenderness of any of her joints. She had no other symptoms but she had been worried about her exams. Her maternal grandmother had osteoarthritis and maternal aunt was crippled with RA. On her clinical examination no positive finding was detected. In particular she had no evidence of active synovitis.

FBC, urea and electrolytes, LFT, RF, ANA, ESR and CRP were normal. She was diagnosed as having nonorganic nocturnal lower limb pains. Parents and the child were reassured that she did not have RA. With firm reassurance within a few weeks her symptoms settled and she was discharged from follow-up.

*Diagnosis:* Idiopathic nocturnal lower limb pains.

## JUVENILE DERMATOMYOSITIS

Juvenile dermatomyositis is an autoimmune disorder consisting of a vasculopathy affecting primarily skin and muscle and frequently other systems. It occurs in children aged 2 years and over, frequently starting insidiously with increasing proximal muscle weakness and the appearance of a purple red diffuse rash most prominent on bony prominences such as knees, elbows, ankles. On the face it involves the heliotrope area around the eyes in particular the upper eyelid (Figs 16.8A and B). On the hands and fingers it appears over the metacarpophalangeal (MCP), PIP and DIP joints and at the fingertips. This characteristic appearance is described as a Gottron's rash (Fig. 16.9). Close inspection of the nail folds, eyelid edges and gums shows erythema and dilated blood vessels suggestive of vasculitis. The myopathy manifests itself with increasing weakness, the child



**Figs 16.8A and B:** Two different patients at diagnosis of juvenile dermatomyositis showing malar and forehead rash and heliotrope discoloration of the upper eyelids

complaining of feeling tired, unable to run, finding difficulty with climbing stairs and having to find support to get off the floor (Gower's sign). Occasionally marked oedema of subcutaneous tissues occurs causing the facial appearance to resemble nephrotic syndrome. Twenty-five percent of cases have associated polyarthritis. The younger the child the more acute tends to be the onset with children becoming very tired and having widespread rash within a few weeks of onset. Rapidly deteriorating cases may have dysphonia, dysphagia, choking due to aspiration and breathing difficulty because of respiratory muscle weakness. In older children, onset may be



**Fig. 16.9:** Juvenile dermatomyositis—Gottron's papules—erythematous papules over MCP and PIP joints



**Fig. 16.10:** Juvenile dermatomyositis—lateral view of the knee showing subcutaneous and interfascial calcification

more insidious. When the child is investigated for lethargy raised blood transaminases may be attributed to liver disease and the patient is referred to gastroenterology.

The diagnosis of JDM is based on a combination of the clinical findings and biochemical abnormalities. Inflamed muscles frequently cause a rise in the level of AST, ALD, LDH, and creatine kinase in the blood whilst gamma GT remains normal. ESR and CRP may be raised. ANF is usually negative. In some cases no biochemical abnormalities are present. Confirmation of the diagnosis used to be made by muscle biopsy and/or electromyography, but these invasive procedures have been superseded by muscle MRI. Inflamed muscle is oedematous and gives a hyperintense signal on MRI T2 weighted scans. MRI is used to compare the appearance of inflamed muscle with that of subcutaneous fat which appears very hyperintense on T2 weighted scans. The higher the muscle to fat ratio, the stronger is the diagnosis.

Juvenile dermatomyositis runs a variable course in different patients. An acute presentation with rapid deterioration tends to happen in younger children less than 5 years of age. Frequently this runs a monophasic course lasting 1–2 years and burns itself out. In older children a more insidious onset tends to occur with the disease smouldering on for several years once it has been controlled with therapy. Occasionally patients run a multiphasic course, with the disease responding to treatment only to flare up again after a few months.

Calcinosis is a long-term complication in many patients especially in those with a florid rash. This takes the form of calcific lumps in the skin and subcutaneous tissues



**Fig. 16.11:** Juvenile dermatomyositis—calcinotic nodules

particularly on bony prominences although it can occur everywhere. Subcutaneous tissues and fascial planes can become calcified giving a hard feel to the skin and in some cases even interfering with mobility (Figs 16.10 and 16.11).

In some cases lipoatrophy may complicate JDM. Localised areas of subcutaneous fat atrophy, leaving the skin thin, wrinkled and lumpy. This is very cosmetically unacceptable to the patient especially the adolescent.



## Treatment of Juvenile Dermatomyositis

It is important to check the inflammatory markers and muscle enzymes before starting therapy but most importantly the childhood myositis assessment scale (CMAS see Appendix E) should be worked out as this is a useful method of assessing improvement in muscle power during therapy.

Initial therapy consists of a rapid control of myositis with steroids and immunosuppression with methotrexate. A rapid response to steroids with minimum side-effects can be obtained by the intravenous administration of methylprednisolone (IVMP) 30 mg/kg per day  $\times$  3 daily doses followed by oral prednisolone 2 mg/kg per day. Single IVMP doses may be repeated at weekly intervals depending on response. Ideally oral prednisolone therapy should be tapered to a small maintenance dose of about 0.1–0.2 mg/kg per day within 3 months of starting therapy. Methotrexate (0.4–0.7 mg/kg per week, orally or subcutaneously) started concurrently should help to control the condition and allow a reduction in steroid dosage. In cases that do not respond to these initial measures other therapeutic agents are useful in controlling the condition. These include monthly infusions of immunoglobulin 2 g/kg per dose, oral cyclosporine and TNF alpha blockers in particular infliximab. Hydroxychloroquine is useful in cases with a florid rash. Patients should be advised to avoid sunlight and to use strong (factor 50) UV blocking agents when outside as exposure to UV light can cause the rash to flare up and activating the myositis.

Calcinosis is best treated by prevention with rapid and adequate control of the disease. Once established it is difficult to remove. Surgical excision of calcified lesions, especially when ulcerated and infected, may be justified. Bisphosphonate therapy with pamidronate has been shown to be of benefit in some but not all patients, causing the lesions to soften and decrease in size.

Plasmapheresis may be of benefit in children with severe life threatening complications that have failed to respond to other measures.

### Key Learning Points

- Elevation of plasma AST and ALT may be caused by both liver and muscle disorders
- Some cases of JMD may not be associated with any biochemical abnormalities

## PAEDIATRIC SYSTEMIC LUPUS ERYTHEMATOSUS

Systemic lupus erythematosus is a multisystem autoimmune disease and the literature continually expands our knowledge

of the varied and seemingly infinite manifestations and course of this complex disorder. Only a few children develop SLE in the early school years. Most cases occur between 11 and 15 years of age and it is more common in girls.

Drug-related lupus is clinically identical with paediatric SLE. In children the most common cause of drug-related lupus is the administration of anticonvulsant drugs.

### Clinical Manifestations

In the childhood form of SLE, as in the adult, the clinical symptomatology may be variable and unpredictable with any number of organ systems eventually becoming involved. The children frequently present with constitutional symptoms and the characteristic erythematous "butterfly" rash on cheeks and bridge of nose although frequently the rash consists of erythema of the cheeks with involvement of the lower eyelid (Figs 16.12A and B). In one-third of patients, the rash is photosensitive. In addition, various skin manifestations may occur such as nonspecific erythemata, purpura, telangiectasia, urticaria, alopecia and abnormal pigmentation. Recurrent mouth ulceration may occur. Raynaud phenomenon is less common in paediatric SLE. Autoimmune haemolytic anaemia, thrombocytopenia and leucopenia may occur.

Lupus nephritis is a grave manifestation, being the most commonly identifiable cause of death in SLE. It is relatively more common and severe in children in China and East Asian countries. Early detection and treatment is essential to prevent progressive and irreversible renal damage and deteriorating renal function.

Joint involvement is common and varies from arthralgia to arthritis closely resembling that of JIA. Cardiac involvement may occur in the form of myocarditis, endocarditis and pericarditis. Manifestations of central nervous system (CNS) involvement include convulsions and mental confusion. Chorea may be a presenting manifestation. Enlargement of the liver and spleen may be found. Lymphadenopathy with generalised lymph gland enlargement is yet another clinical manifestation. There may be a rapidly progressive retinopathy and extensive retinal haemorrhages, exudates and papilloedema. Anti-phospholipid syndrome (APS) has been reported in patients with SLE. The clinical manifestations depend upon the site of the thrombotic process, which may involve arterial and venous vessels of any size in any organ. The diagnosis of APS requires a high degree of clinical awareness. APS is a potentially life-threatening condition. Treatment of APS is the use of antiplatelet agents and anticoagulants in addition to the control of the underlying SLE.



**Figs 16.12A and B:** Systemic lupus erythematosus: (A) Malar—butterfly rash; (B) Same patient with extreme iatrogenic hypercorticism (Cushingoid syndrome)

### Laboratory Findings

The diagnosis of SLE is associated with the detection of a large assortment of autoantibodies. One characteristic finding is that of a high ESR in the presence of a normal CRP. The presence or absence of particular autoantibodies influences the confidence with which this diagnosis is made. Antinuclear autoantibodies are present in up to 100% of patients. Antidouble stranded DNA (ds DNA) has 100% specificity for SLE, but only 50% sensitivity. Antisingle stranded DNA (anti-ssDNA) is relatively nonspecific and commonly found in other connective tissue disorders. For a detailed autoantibody profile in connective tissue disorders in children is given in Box 16.1.

#### Box 16.1: Autoantibodies in connective tissue disorders in children

Autoantibody	Disease
Antinuclear antibody	SLE, JIA, JDM, scleroderma
Antibodies to extractable nuclear antigen	SLE, MCTD
C1q antibody	SLE (particularly lupus nephritis)
Anticardiolipin antibodies	SLE, APS
Double-stranded DNA antibodies	SLE
Histone antibodies	Drug-induced lupus
Lupus anticoagulant	SLE, APS
Rheumatoid factor	JIA
Ro/SS-A	SLE, neonatal lupus
ScI-70	Scleroderma
Anti-Sm antibodies	SLE
U1-RNP	Lupus nephritis, MCTD
Centromere antibodies	CREST syndrome

(Abbreviations: SLE—systemic lupus erythematosus; JDM—juvenile dermatomyositis; JIA—juvenile idiopathic arthritis; MCTD—mixed connective tissue disease; CREST—calcinosis, Raynaud's, oesophageal dysmotility, sclerodactyly, telangiectasia)

### Treatment and Prognosis

The advent of steroid therapy made it possible to reverse what was invariably a progressive condition leading to increasing morbidity and mortality. Rapid suppression of disease can be achieved by weekly pulses of intravenous methylprednisolone (30 mg/kg per day) in addition to oral prednisolone (1–2 mg/kg per day) the dose of which is gradually tapered as disease control is gained with immunosuppression. Most patients need to continue on a small daily maintenance dose of prednisolone to remain controlled. In cases with severe renal involvement or life-threatening complications or poor response to therapy, monthly pulsed intravenous cyclophosphamide, in addition to steroid therapy, is used to induce rapid disease control. The use of oral azathioprine has been superseded by mycophenolate mofetil (MMF) as an immunosuppressant for disease control. Aspirin 75 mg daily is recommended in all SLE patients as an anti-platelet agent. Hydroxychloroquine is routinely administered for its protective effect against atherosclerosis, a long-term complication of the disease and of long-term steroid therapy. Other drugs may be indicated depending on the type of disease manifestation. Patients with problematic Raynaud's disease may benefit from peripheral vasodilators such as amlodipine. In severe cases the use of more powerful vasodilators, such as Iloprost, may be needed. All patients should avoid exposure to sunshine as UV irradiation can trigger both the cutaneous and systemic disease. Benefit has been reported in the management of severe cases by the administration of rituximab which ablates the B cells and has been shown to have a beneficial effect in disease control in severe cases.

### NEONATAL LUPUS ERYTHEMATOSUS

Infants born to mothers with active SLE may present with manifestations of SLE such as skin rash, thrombocytopenia,

leucopenia and haemolytic anaemia. Most manifestations of neonatal lupus resolve with the clearance of transplacentally transferred maternal antibodies and rarely require treatment. All signs usually clear by 6 months of age. However, in babies of mothers who are anti-SSA/Ro (anti-Ro) positive, there is a risk of complete heart block, which is present from birth, is permanent and usually needs pacing.

#### Case Study

An 8-year-old girl presented with a 3-month history of feeling very tired, unable to walk, ulcers in her mouth, painful knees, wrists, elbows and fingers and a facial rash. She had been off school for 2 months. On examination she had a typical butterfly facial rash and active synovitis of knees, wrists and elbows. Blood pressure 100/60 mmHg. No other positive finding was detected. The following investigations were carried out; haemoglobin (Hb) 8.5 g/dl, WBC  $3.3 \times 10^9/L$ , neutrophils  $2.4 \times 10^9/L$ , platelet count  $391 \times 10^9/L$ , ESR 75 mm in first hour, CRP less than 7 clotting profile normal, aspartate aminotransferase (AST) 40 IU/L, alanine aminotransferase (ALT) 30 IU/L, albumin 31 g/L, protein 80 g/L. Creatinine 36  $\mu\text{mol/L}$ , urea 5.2 mmol/L, creatine kinase 42 IU/L, complement C3 0.26 g/L ( $\downarrow$ ), complement C4 0.06 g/L ( $\downarrow$ ) urine clear (Dipstix) Direct Coomb's test positive, ANA titre 1:2,560, double stranded DNA more than 1,000 IU/ml, Crithidia test positive, anti-Ro positive, anti-Sm negative, anti-RNP negative, anti-Scl-70 positive, anti-Jo-1 positive, IgG cardiolipin antibody less than 10 IU/ml(N) IgM cardiolipin antibody less than 10 IU/ml(N).

She was initially treated with pulse methylprednisolone and a course of oral prednisolone. She responded to this treatment and did not develop lupus nephritis or any other complication.

*Diagnosis:* Active paediatric SLE.

## JUVENILE SCLERODERMA

Scleroderma is a poorly understood autoimmune connective tissue disease. It is rare in children, most cases presenting with localised disease. Systemic disease (systemic sclerosis) is even rarer in children.

### Juvenile Localised Scleroderma (Morphea, Linear Scleroderma)

#### Morphea

Morphea is a rare type of scleroderma. Onset is insidious anytime during childhood and frequently several years pass before a diagnosis is made. Lesions can appear over any part of the body, more frequently on the trunk, starting as erythematous areas which gradually expand in size with a peripheral pink edge and a central slightly pigmented area of atrophic skin through which dilated blood vessels are visible due to atrophy of the subcutaneous fat (Fig. 16.13A). Lesions

may be slightly pruritic but are not usually painful. They are cosmetically unacceptable especially on visible parts of the body. Without treatment new ones continue to appear for several years. Once established lesions tend not to regress. They are not usually associated with systemic disease.

#### Linear Scleroderma

Localised scleroderma is a rare disease. The children present with slowly progressive lesions on their upper and lower limbs, sometimes on the trunk, which consist of localised patches of oedematous, thickened, shiny skin, sometimes tethered to underlying bone. In long-standing cases, the affected limb may be shortened or deformed (Fig. 16.13B).



**Figs 16.13A and B:** Morphea: (A) Localised morphea on knee; (B) Linear scleroderma affecting left lower limb showing growth failure of the limb

## Scleroderma En Coup De Sabre

In this type of scleroderma lesions appear on the face and scalp consisting of linear depressed lesions of atrophied skin and underlying subcutaneous tissue and bone, resembling a saber cut. They are very disfiguring causing the patient considerable distress. They are not usually associated with systemic disease.

## JUVENILE SYSTEMIC SCLEROSIS

Systemic sclerosis is exceptionally rare in childhood and its course unpredictable. The patches of skin with scleroderma become oedematous, atrophic and inelastic and adherent to the underlying tissues. The consequent atrophy and tightening of the skin gives a characteristic facial appearance of pinched nose and pursed lips. The hands become shiny with tapered finger ends due to loss of pulp. Restricted movement produce claw-like deformities which may also affect the feet. Raynaud's phenomenon is common. GI system involvement with oesophageal dysmotility and dysphagia and long-term fibrosis is much less common in the childhood form of the disease. Pulmonary fibrosis and hypertension and renal involvement may occur. Sjögren syndrome (Sicca syndrome of dry mouth and eyes) is not uncommon in this condition. An apparently slowly developing form of scleroderma, described largely in adults and called CREST syndrome, may be found in children. CREST is an acronym for calcinosis, Raynaud's phenomenon, oesophageal dysfunction, sclerodactyly and telangiectasia.

There are no specific laboratory tests diagnostic of scleroderma. ANA are frequently present in sera of children with juvenile systemic sclerosis. The auto-antibody Scl-70 can be identified in some cases.

## Treatment

The mainstay of therapy in all types of scleroderma is a combination of steroids in the form of methylprednisolone pulses and daily oral prednisolone together with immunosuppression with methotrexate. Response to therapy is slow with improvement only becoming detectable after the first 6 months of therapy. Mycophenolate mofetil (MMF) is increasingly used as an alternative to methotrexate. Progression of the disease can be slowed and cases of morphoea and linear scleroderma can be switched off with some reversal of the skin lesions. Scleroderma en coup de sabre is irreversible. In systemic sclerosis serious complications such as pulmonary hypertension and fibrosis and nephritis constitute an indication for more powerful immunosuppression with cyclophosphamide.

Treatment has to continue for several years, if not lifelong and these children need psychosocial support. In addition

physiotherapy and occupational therapy provide ways of helping these children overcome any disabilities resulting from contractures and limited mobility due to their disease.

## VASCULITIC SYNDROMES

There are four main groups of vasculitic syndromes of children. The two most common ones are of acute onset and include HSP and Kawasaki disease. More insidious and long-lasting types of vasculitis include polyarteritis nodosa, Takayasu's disease and Wegener's granulomatosis. Behcet syndrome is more common in Middle Eastern countries than in Western Europe. This section will deliberately concentrate on the vasculitic diseases of significance to the general paediatrician.

## Henoch-Schönlein Purpura

Henoch-Schönlein purpura is a systemic small vessel vasculitis, involving skin, joints, abdomen and the kidney. Other organs less frequently affected include the CNS, gonads and the lungs, although less common clinical features may arise from involvement of virtually every organ system. Certain vaccines, various microbial pathogens, environmental agents and various drugs have been implicated in the aetiology of HSP, but definite supporting evidence for any of them is lacking. IgA1 plays a pivotal role in the pathogenesis of HSP.

The disease has a wide variety of manifestations but the diagnosis is usually obvious when the characteristic purpuric rash on lower and upper limbs is present (Figs 16.14A and B). The most prominent symptoms arise from swollen painful joints, or from areas of angio-oedema elsewhere. In some children the onset is with severe abdominal pain with or without melaena. Intussusception occurs in a small number of cases and when suspected the diagnosis can be confirmed with ultrasound of the abdomen. Another mode of presentation in boys is with an acute scrotal swelling which can be mistaken for torsion of the testis. In the majority of cases the rash is the most striking feature and causes the parents to seek medical advice but sometimes it may appear after the abdominal pain. Characteristically the rash appears first as small separate urticarial lesions, both visible and palpable. These soon become dusky red or frankly purpuric. In the typical case the rash is most profuse over the extensor surfaces of the knees, ankles, dorsum of the feet, arms, elbows and forearms. The face, abdomen and chest are completely spared. On the contrary the purpuric/petechial rash in meningococcal disease may appear on any part of the body. CNS involvement may present as headache, seizure or hemiparesis. Lung involvement presents as pulmonary haemorrhage.



**Figs 16.14A and B:** Henoch-Schönlein purpura: (A) Purpuric rash on buttocks; (B) Rash on legs

Renal involvement is more common than is usually recognised and may occur in 20% of children. The clinical presentation can vary from microscopic haematuria to typical acute glomerulonephritis or nephrotic syndrome. While the majority of children with renal involvement make a complete recovery a few may go on to develop persistent proteinuria, hypertension and deteriorating renal function. It is suggested that urinalysis should be carried out for 2 months after resolution of the rash, to ensure that renal involvement is not missed.

There are no specific laboratory tests which would help with the diagnosis of HSP. The platelet count is within the normal range. Coagulation studies are normal.

### Key Learning Points

- Characteristic distribution of HSP rash should help distinguish it from meningococemia.
- HSP is the most common vasculitis in children.
- HSP is generally a self-limited condition—lasts an average of 4 weeks.
- Nephritis is one feature of HSP that may have chronic consequences.
- Long-term prognosis is dependent on the severity of nephritis.

### Treatment

There is no specific treatment for HSP, and a large majority of children will require no treatment. The supporting treatment is aimed at symptomatic relief of arthritis and abdominal pain. NSAIDs seem to be effective in most cases and there is no evidence that they induce GI haemorrhage in these children. Prednisolone at a dose of 1 mg/kg per day seems to reduce the duration of abdominal pain and joint pain. In addition to corticosteroids, cyclophosphamide, azathioprine, cyclosporine and MMF have been used in the treatment of patients with severe nephritis.

### Key Learning Point

- Characteristic distribution of purpuric lesions in HSP should help to distinguish it from meningococcal disease, where the rash may appear on any part of the body.

### Kawasaki Disease

Kawasaki disease is the most common cause of multisystem vasculitis in childhood. The vessels most commonly damaged are the coronary arteries, making Kawasaki disease the number one cause of acquired heart disease in children from the developed world. It is characterised by prolonged fever, nonpurulent conjunctivitis, oral mucosal inflammation, skin changes and cervical lymphadenopathy, induration and erythema of the hands and feet (Figs 16.15A to C). It was described by Dr Tamasaku Kawasaki in the Japanese literature in 1967 and in the English literature in 1974. Since then it has been recognised in children of every ethnic origin although Asian children are affected 5–10 times more frequently than Caucasian children. It is a disease of young children and 80% of cases are younger than 5 years. The peak age of onset is 1 year and the disorder is more common in boys.

A definite diagnosis of Kawasaki disease can be made when at least five of the following six principal signs are present:



**Figs 16.15A to C:** Kawasaki disease: (A) Strawberry tongue and sloughing of filiform papilla; (B) Non-purulent conjunctivitis; (C) Desquamation of thumb

1. Fever persisting for 5 or more days
2. Polymorphous rash
3. Bilateral conjunctival congestion
4. Changes of lips and oral cavity including strawberry tongue, red fissured lips, hyperaemia of oral and pharyngeal mucosa

5. Acute nonpurulent cervical lymphadenopathy.
6. Changes in peripheral extremities including reddening of palms and soles, oedema of hands and feet, membranous desquamation of fingertips.

In the absence of pathognomonic clinical or laboratory signs, it is extremely difficult to diagnose mild or incomplete cases. Therefore, it is essential sometimes to keep an open mind and occasionally follow a child as a "possible case" with repeated clinical and cardiac evaluations. However, in most cases the diagnostic criteria are clearly identifiable and a definite diagnosis of Kawasaki disease can be made.

Coronary artery aneurysms develop approximately in 15–20% of untreated children with Kawasaki disease, within 4–6 weeks of disease onset. Two-dimensional (2-D) echocardiography will detect nearly all patients with acute coronary artery disease.

Other less frequent features include arthritis, arthralgia, urethritis, diarrhoea, aseptic meningitis, sterile pyuria, myocarditis, pericarditis, alopecia, jaundice, uveitis and hydrops of the gallbladder. Blood tests show leucocytosis, a raised ESR/CRP and during the second week of illness there may be thrombocytosis.

### Treatment

Early initiation of aspirin therapy and a single dose of intravenous normal immunoglobulin (IVIG) remains the mainstay of treatment. This combination has an additive anti-inflammatory effect resulting in faster resolution of fever and a decreased incidence of coronary artery complications. Aspirin is used for its anti-inflammatory and anti-thrombotic effects. Initially aspirin is given to obtain anti-inflammatory effect by giving doses of 30–80 mg/kg per day in four divided doses, in the acute phase of illness. Thereafter, it is reduced to 3–5 mg/kg per day for its antiplatelet effect. Aspirin should be continued until ESR and platelet count return to normal, unless coronary artery abnormalities are detected by echocardiography. Dipyridamole may be used for treatment of persistent coronary artery aneurysms in Kawasaki disease.

Treatment with IVIG for all children diagnosed within the first 10 days of illness reduces the incidence of coronary artery aneurysms by 70%. The recommended dose of IVIG is 2 g/kg and it should be administered as a single dose over 8–12 hours. However, children with a delayed diagnosis of Kawasaki disease may also benefit from IVIG.

### Case Study

A 2-year-old boy presented with a 5-day history of fever, cough, runny nose and a macular rash on his trunk. On examination he had suffusion of ocular conjunctivae, bilateral cervical lymphadenitis, an inflamed throat, strawberry tongue, induration of palms and soles and a temperature of 40°C. He had no hepatosplenomegaly, arthritis and no peeling of skin and no neck

stiffness. Hb 10 g/dl, WBC  $20 \times 10^9/L$  with preponderance of polymorphs. Platelet count  $600 \times 10^9/L$ . ESR 80 mm in first hour. CRP 60 mg/L. 2-D echocardiography showed dilatation of right coronary artery. Urine clear both biochemically, microscopically and bacteriologically. Viral serology was negative.

The most likely working diagnosis was Kawasaki disease. He was treated with aspirin and IVIG. He recovered unscathed and did not develop any problems.

### Juvenile Polyarteritis Nodosa

Juvenile polyarteritis nodosa (PAN), a rare systemic vasculitis, may present with a wide variety of clinical manifestations. It is a necrotising vasculitis of medium sized muscular arteries with associated aneurysmal formation.

Clinically the symptoms are due to involvement of the vessels of the kidney, CNS, muscle and viscera. Coronary artery involvement and myocardial infarction may occur.

No specific serological markers are available for the diagnosis of PAN although some patients may have circulating anti-neutrophil cytoplasmic antibody (ANCA). Skin or muscle may be biopsied to detect histological changes of fibrinoid necrosis of small and medium sized arterial walls. Renal biopsy is generally avoided as there is a significant risk of bleeding. Corticosteroids can improve the prognosis; the effects of the disease process may be suppressed and symptoms relieved, but the underlying condition is not cured. It is usual to start corticosteroids at fairly high dose and then reduce it to the lowest level, which would control the disease. However, knowledge about the management of refractory juvenile PAN is limited.

### Juvenile Takayasu Arteritis

Juvenile Takayasu arteritis (TA) is another vasculitic disorder affecting mainly the aorta and its larger branches causing both stenosis and aneurysms. It is more common in female adolescents, presenting with systemic manifestations of lethargy, fever, myalgia, arthralgia and sometimes arthritis, followed by breathlessness, dyspnoea headaches and palpitations, secondary to severe hypertension. This is a consequence of stenosis of the aorta or its major vessels or renal artery stenosis which cause severe systemic hypertension and in some cases pulmonary hypertension. Examination of the peripheries reveals absent pulses and auscultation over the major blood vessels shows the presence of bruits over

the stenotic areas. Diagnosis is confirmed with angiography. High dose steroid therapy and immunosuppression with methotrexate and cyclophosphamide are useful in some cases but the prognosis is always guarded.

### Behcet's Disease

This is a rare disease in the United Kingdom but is much more common in the Middle East, Japan especially Turkey presenting in adolescents between 10 and 16 years of age and continuing into adulthood. It is characterised by the triad of recurrent aphthous stomatitis, genital ulceration and severe anterior uveitis. Skin manifestations include erythema nodosum and skin ulcers. Venous thrombosis and aneurysm formation are the result of vasculitis. GI involvement resembles inflammatory bowel disease. Therapy with steroids and methotrexate is effective in controlling many cases but some need stronger immunosuppression with cyclophosphamide. Colchicine is useful in managing recurrent oral ulceration.

### Wegener's Granulomatosis

This granulomatous vasculitis is rare in the paediatric age group. The granulomatous vasculitis has a predilection for the upper and lower respiratory tract, glomerulonephritis and cutaneous vasculitis. Upper respiratory tract involvement includes sinusitis, epistaxis, nasal mucosal ulceration associated with perforation of the nasal septum and hearing loss. Lower airways disease causes cough, haemoptysis and pleuritis. Glomerulonephritis is encountered in about half the patients and is rapidly progressive leading to renal failure if not treated. Cutaneous lesions take the form of deep ulcers on face and legs although other sites may be also involved. The ESR is markedly elevated. RF is positive in some patients. Most patients are cANCA positive. Treatment with high doses steroid therapy (methylprednisolone pulses plus oral prednisolone) and cyclophosphamide have vastly improved the prognosis in what is otherwise a fatal condition.

### BIBLIOGRAPHY

1. Huber AM, Feldman BM, Rennebohn RM, et al. Validation and clinical significance of the childhood myositis assessment scale for assessment of muscle function in juvenile idiopathic inflammatory myopathies. *Arthritis Rheum.* 2004;50(5):1595-603.

# The Urinary System

## INTRODUCTION

Over the past four decades progress has been achieved in the classification of renal disease and this has been particularly in the realm of glomerular disorders. This has been possible because of electron microscopy and immunofluorescence in the identification within renal tissue of immunoglobulins and complement components. On the basis of experimental work it has been shown that there are mainly two types of immunologically mediated glomerular diseases:

1. Due to deposition of antigen-antibody complexes (immune complex glomerulonephritis); and
2. Due to the action of autoantibodies against constituents of glomerular basement membrane (anti-GBM disease).

Classification at present is based on a combination of factors, e.g. aetiological agents, association with systemic disease, identification of basic immunopathogenic mechanisms and correlation with clinical findings (Table 17.1).

Interestingly the spectrum of paediatric renal diseases in Asian countries is similar to that seen in the Western countries although certain conditions are more common such as post-dysenteric haemolytic uraemic syndrome, malarial nephropathy, hepatitis-B nephropathy and nephropathy associated with leptospirosis, snake-bite and other envenomations. In this chapter only common glomerulonephritides in relation to paediatric practice will be discussed.

## ACUTE POST-STREPTOCOCCAL GLOMERULONEPHRITIS

Acute post-streptococcal glomerulonephritis (APSGN) is a syndrome consisting of frank haematuria, proteinuria with accompanying oliguria, volume overload and usually, a mild increase in plasma creatinine. In the Indian sub-continent, China, Thailand, Nigeria, South Africa, APSGN is common as compared to its incidence in the Western countries. In

**Table 17.1:** Classification of glomerulonephritis

Primary glomerulonephritis
Acute post-streptococcal glomerulonephritis
IgA nephropathy
Anti-glomerular basement membrane antibody disease
Goodpasture syndrome
Glomerulonephritis of uncertain aetiology
Minimal change nephrotic syndrome (MCNS)
Focal segmental glomerulosclerosis (FSGS)
Membranous nephropathy
Glomerulonephritis associated with systemic disease and infections
Henoch-Schönlein purpura, systemic lupus erythematosus, scleroderma, polyarteritis nodosa, Wegener granulomatosis, infective endocarditis, shunt nephritis, hepatitis B and C, malaria, syphilis, toxoplasmosis, parvovirus B19, cytomegalovirus, filaria, HIV associated renal disease, Epstein-Barr virus infection.
Hereditary disorders
Congenital nephrotic syndrome
Familial nephritis-Alport syndrome, Sickle-cell disease
Other conditions
Diabetes mellitus, amyloidosis, heavy metal poisoning - mercury

most cases there is a history of a preceding infection 7–21 days before the onset of renal manifestations. In the majority this infection is due to one of the group A beta-haemolytic streptococci, most often nephritogenic types 4, 12, 25 and 49. It has been presumed that during the latent period of 7–21 days an antigen-antibody reaction takes place between the streptococcal endotoxin and the cells of the glomerulus. The underlying renal histology is typically an acute proliferative glomerulonephritis.

Apart from the cases due to streptococcal pharyngitis, some cases may occur following skin infection (pyoderma) or rarely middle ear infection. In developing countries the



outbreaks of APSGN are often due to pyoderma while in developed countries they are associated with pharyngeal infection. The simultaneous occurrence of acute rheumatic fever and APSGN has been reported but is extremely rare.

### Clinical Features

Usually the child is of school age and the onset is abrupt with fever, malaise, headache, vomiting and the passage of red, or smoky or brown coloured urine. The preceding tonsillitis or other cutaneous infection has usually resolved by this time. Examination reveals mild oedema, most obvious in the face and hypertension of moderate severity. Urinary output is reduced. There is proteinuria but it is usually in the non-nephrotic range (<2 g/l). Microscopy of urine shows red blood cell (RBC) casts and hyaline or granular casts are less frequent during the acute phase. Causes of dark or discoloured urine are shown in Box 17.1.

#### Box 17.1: Causes of dark or discoloured urine in children

Rifampicin  
Nitrofurantoin  
Metronidazole  
Desferrioxamine  
Beetroot  
Black-berries  
Urate crystals  
Myoglobinuria  
Haemoglobinuria  
Alkaptonuria, porphyria  
Food colourings (beetroot, berries-anthocyanins and confectionary containing vegetable dyes)

#### Key Learning Point

- It is essential to establish that red urine is due to haematuria by looking for RBC on urine microscopy.

Haemolytic streptococci are frequently isolated from the throat swab and in most cases the antistreptolysin-O (ASO) titre is raised within 10–14 days following a streptococcal infection and anti-DNase B will be positive. The blood urea and serum creatinine concentrations are frequently raised but a normal level need not invalidate the diagnosis. During the first week or two of APSGN very low levels of serum complement are found which rise as recovery takes place. Box 17.2 shows investigations of APSGN.

### Course and Prognosis

The prognosis of APSGN in childhood is excellent. Complete recovery can be expected in about 90% of children without significant alteration in renal function. Resolution of the oliguria usually occurs within a week and this is associated with blood pressure normalisation and a fall in plasma creatinine. Frank haematuria may remain for 2–3 weeks

but in the longer-term, proteinuria is usually gone by 3–6 months and microscopic haematuria by 1–2 years. Rarely, the disease shows long-term complications, worsening to chronic kidney disease requiring long-term interventional measures.

#### Box 17.2: Investigations of acute post-streptococcal glomerulonephritis

Full blood count  
U and Es  
Liver function tests  
Immunoglobulins  
ASO titre (Anti-DNase B)  
Complement screen  
Antinuclear factor (ANF)  
Urine protein creatinine ratio  
Urine culture  
Renal ultrasound

### Treatment

The treatment of APSGN is symptomatic. It includes fluid and salt restriction and management of the associated hypertension with nifedipine and frusemide. Also atenolol and enalapril can be used for lowering the blood pressure. Penicillin should be prescribed at the start of treatment to eradicate any surviving haemolytic streptococci, e.g. oral penicillin-V 250 mg four times daily for children aged 6–12 years and 125 mg four times daily for children aged 1–6 years daily for 7 days or erythromycin 50 mg/kg per day in four divided doses orally for 10 days as an alternative to penicillin in hypersensitive patients.

Since immunity to nephritogenic streptococci is type specific and long-lasting, recurrent attacks of APSGN are rare. Therefore penicillin prophylaxis as in acute rheumatic fever is not indicated.

#### Case Study

A 5-year-old girl presented with an acute onset of periorbital puffiness and tea coloured urine. Three weeks previously she had a sore throat from which she had recovered. She also complained of headache, nausea and vomiting and abdominal pain. She had oliguria.

On examination she had periorbital puffiness and minimal ankle oedema. Blood pressure was 90/60 mm Hg (normal for her age). Urine revealed 4+ blood and 2+ protein and RBC casts. Blood urea 10 mmol/L and creatinine 140 mmol/L. Complement C3 was 0.6 g/L (low) but C4 was normal. ASO titre 1,200 Todd units/ml. Hb 10g/l, WBC and platelet counts normal. Her haematuria and proteinuria resolved by 6 weeks. Complement C3 returned to normal range at 8 weeks. She recovered unscathed.

*Diagnosis:* Acute post-streptococcal glomerulonephritis

## PRIMARY IGA NEPHROPATHY

Primary IgA nephropathy (IGAN) occurs at all ages but is common during the second or third decades of life and affects boys more often than girls. It seems to be uncommon in India but it is probably the most common chronic glomerulonephritis in other parts of the world, e.g. Japan, France, Italy and Australia.

The most common clinical presentation of IgA nephropathy is recurrent episodes of painless haematuria following an upper respiratory infection. The interval between the appearances of haematuria ranges from 1–2 days compared to 1–2 weeks in APSGN. Serum IgA levels are increased in this condition but serum complement concentrations are usually normal. The normal level of complement concentration differentiates it from post-infectious glomerulonephritis. A proven form of therapy for IgA nephropathy does not exist.

## NEPHROTIC SYNDROME

This is the commonest clinical syndrome in the world. It is characterised by gross proteinuria ( $>1 \text{ g/m}^2$  per 24 hr) and hypercholesterolaemia are always present. Oedema resulting from build-up of salt and water is usually severe. Other abnormalities such as raised plasma aldosterone and anti-diuretic hormone levels are prominent in children with massive proteinuria and oedema. Hypertension, azotaemia and haematuria either microscopic or frank rarely occur in childhood. The cause of idiopathic nephrotic syndrome remains unknown, but evidence suggests it may be a primary T-cell disorder—the most common form that leads to glomerular podocyte dysfunction.

Idiopathic nephrotic syndrome has a reported incidence of two to seven cases/100,000 children. However, in the Indian sub-continent the incidence is estimated at 90–100/million population. There are three distinct histological variants of primary idiopathic nephrotic syndrome:

1. Minimal-change nephritic syndrome (MCNS)
2. Focal segmental glomerulosclerosis (FSGS)
3. Membranous nephropathy.

Minimal change nephrotic syndrome and focal segmental glomerulosclerosis may represent opposite ends of one pathophysiological process or distinct disease entities. By contrast, membranous nephropathy is a distinct disease and is rare in children.

### Clinical Features

Although the idiopathic nephrotic syndrome is seen at all ages the majority of cases occur between 1½ and 5 years. It seems to affect boys more often than girls. Its occurrence in siblings is rare. The first manifestation is oedema which causes swelling of the face, legs and abdomen, often starting

after a viral upper respiratory tract infection. Gross ascites is the rule; indeed in some children peripheral oedema may be relatively slight while ascites is massive in amounts. Hypertension is typically absent. Proteinuria is also very heavy; at least 10 g may be lost each day. Haematuria is uncommon. Appropriate laboratory studies establish the correct diagnosis Box 17.3.

#### Box 17.3: Investigation in a child with nephrotic syndrome

FBC, U and Es, creatinine, LFTs, ASO, C3/C4  
 Urine culture, urinary protein/creatinine ratio  
 Blood culture  
 Urinary sodium concentration in those children at risk of hypovolaemia  
 Varicella status prior to steroid therapy

## Complications of Nephrotic Syndrome

The main complications are infection, thrombosis and hypovolaemia.

### Infectious Complications

Many children with nephrotic syndrome died of intercurrent pyogenic infections in the pre-antibiotic era. This susceptibility is presumably due to the decreased level of factor B, transferrin and immunoglobulins lost in urine. The most typical infection is primary pneumococcal peritonitis although pneumonia and cellulitis, empyema, bone and joint infections, sepsis and tuberculosis are also common. In the Indian subcontinent tuberculosis is a problem. Therefore every child with nephrotic syndrome should be screened for the presence of tuberculosis before starting steroid therapy and to exclude it during the subsequent management. Pneumococcal vaccination is recommended for children who have nephrotic syndrome.

### Thromboembolic Complications

Thromboembolism is the most severe and fatal complication of nephrotic syndrome.

### Hypovolaemia

Children with nephrotic syndrome while very oedematous could be intravascularly depleted. A urinary sodium of  $< 10 \text{ mmol/L}$  is a good marker of hypovolaemia.

## Management

Before the introduction of corticosteroids there was no satisfactory form of therapy. Fortunately it is now possible in the majority of nephrotic children to induce diuresis and complete or partial remission of proteinuria with steroids. Bed rest is rarely indicated.

A well balanced and healthy diet containing the recommended dietary reference value for protein is

recommended with a "no added salt" regimen. If the child's appetite remains poor, a complete nutritional and energy supplement is necessary. Fluid restriction may also be helpful. These restrictions are lifted once the child goes into remission.

### Treatment of Initial Presentation of Idiopathic Nephrotic Syndrome

On the basis of randomised controlled trials involving children with a first episode of steroid-responsive nephrotic syndrome it is recommended that a 12 weeks initial course of prednisolone significantly decreases the risk of relapses. The dose of prednisolone is based on surface area and the recommended 12 weeks programme is as follows:

- Prednisolone 60 mg/m<sup>2</sup> daily for 4 weeks followed by
- Prednisolone 40 mg/m<sup>2</sup> on alternate days for 4 weeks followed by
- Prednisolone 5–10 mg/m<sup>2</sup> each week for another 4 weeks and then stop

Traditionally patients receive divided doses but once daily treatment also seems to be effective.

If the patient is very oedematous, oliguric, showing evidence of hypovolaemia, intravenous 20% salt poor albumin, 1 g/kg given over 4–6 hours is very effective, particularly if supplemented by intravenous frusemide 2 mg/kg. A low serum albumin alone is not an indication for intravenous albumin.

#### Key Learning Point

##### ► Steroid Responsive Nephrotic Syndrome

Roughly 95% of children with nephrotic syndrome (MCNS) will respond to steroid therapy within 2–4 weeks. A remission is defined when urine is free of protein (or trace only) for 3 or more days. If proteinuria persists beyond the first 4 weeks of steroid therapy, the child should have a renal biopsy.

### Frequently Relapsing and Steroid-Dependent Idiopathic Nephrotic Syndrome

Up to 60% of steroid responsive patients with nephrotic syndrome may have one or more relapses. Some of these children can be managed with low-dose prednisolone given daily or on alternate days, but many will still relapse, especially if they have intercurrent infections. Steroid-induced side-effects develop in a large number of these children.

Frequent relapses are diagnosed if there is two or more relapses within 6 months of initial response, four or more relapses in any 12 months period and steroid dependent nephrotic syndrome if two consecutive relapses during steroid tapering or within 14 days of cessation of steroids. Treatment with cyclophosphamide, chlorambucil, ciclosporin and levamisole to reduce the risk of relapses is supported. Ciclosporin is an important steroid sparing agent in the treatment of steroid-responsive nephrotic syndrome.

The proportion of children with frequent relapses and steroid dependence in the Indian sub-continent is high but the final outcome is satisfactory.

### Steroid-Resistant Idiopathic Nephrotic Syndrome

The management of children with steroid-resistant nephrotic syndrome is difficult, most children failing to achieve remission show progressive renal damage.

A few children around 20–25% with idiopathic FSGS respond to an 8 weeks course of high dose corticosteroids. However, immunosuppressive drugs such as cyclophosphamide, levamisole, chlorambucil and ciclosporin have provided an alternative line of treatment for these children. Also, newer immunosuppressive agents, such as mycophenolate mofetil and sirolimus, have a place in the treatment of idiopathic primary FSGS.

#### Key Learning Point

##### ► Steroid Toxicity

Cushingoid facies, obesity, hirsutism, striae, hypertension, impaired glucose tolerance, posterior subcapsular cataracts, emotional problems and growth retardation.

### Course and Prognosis

The main prognostic indicator in nephrotic syndrome is responsiveness to steroids. On the whole as many as 60–80% of steroid responsive nephrotic children will relapse and about 60% of those will have five or more relapses. If the child is more than 4 years of age at presentation and remission occurs within 7–9 days of the start of treatment without haematuria are predictive of fewer relapses. Finally, steroid resistant FSGS children with the current treatment modalities available a few will achieve a sustained remission. For children with refractory nephrotic syndrome progress to end-stage renal disease is inevitable.

## CONGENITAL NEPHROTIC SYNDROME

Congenital nephrosis is a rare disorder in which inheritance is probably autosomal recessive. It appears to have a peculiarly high and familial incidence in Finland (Finnish type). The hallmarks of the disease are an abnormally large placenta associated with heavy proteinuria, oedema and ascites. It is unresponsive to steroid therapy and cytotoxic drugs but indometacin (indomethacin) and an ACE inhibitor such as captopril have been used. The affected infants die from intercurrent infections or progressive renal failure.

Another condition that causes nephrotic syndrome in the first months of life is diffuse mesangial sclerosis. The pattern of inheritance is not yet clear although it appears to be genetic.

## URINARY TRACT INFECTIONS

Urinary tract infection (UTI) is one of the most common diseases of paediatric practice. The most common infecting organism is *E. coli* and the highest incidence of disease is in the first 2–3 years. Less frequently, the organisms are the *Streptococcus*, *Pseudomonas aeruginosa* and rarely the *Salmonella* group. A child infected with a non-*E. coli* organism is defined as having atypical UTI. There has long been controversy as to the route by which the organisms reach the kidney. Haematogenous spread undoubtedly occurs, especially in the newborn, but the present tendency is to attach more importance to ascending infection via the urethral lumen or the lymphatics. Urinary stasis due to congenital anomalies of the renal tract or to acquired causes of obstruction such as calculi predisposes to infection.

### Clinical Features

Urinary tract infections occur four times more frequently in girls than in boys, with the exception of the first 6 months of life. The higher female incidence after the early months of life has been attributed to the short female urethra and ascending infections.

The onset of the acute stage is usually sudden with fever, pallor, anorexia, vomiting and tachycardia. UTI is one of the few causes of rigor in young children. However, in children, symptoms pointing to the renal tract are often absent. In some cases, however, the mother may have observed that there is frequency of micturition or that the infant screams during the act of urination.

In older children frequency and dysuria make diagnosis easier although their absence does not exclude the diagnosis. Some children may present with enuresis.

#### Key Learning Points

- Indications for examining urine; suspecting UTI abdominal pain and unexplained vomiting, loin tenderness
- Frequency of micturition, dysuria or enuresis
- Failure to thrive
- Prolonged jaundice in the newborn
- Non-specific illness
- Haematuria, offensive urine, cloudy urine
- Fever, poor feeding, unexplained fever of 38° or higher
- Lethargy, irritability.

#### Key Learning Points

- Urine analysis should be part of routine investigation of every ill infant or child.
- A pure growth of more than  $10^5$  colony forming units or any growth on suprapubic tap urine is significant.

### Diagnosis

The diagnosis must be based upon examination of the urine including microscopy and culture. Collect urine using a clean catch sample. If there is any delay, storage at 4°C will permit accurate diagnosis certainly for 24 hours. Urine microscopy can make a useful contribution to diagnosis, especially when urgent treatment needs to be initiated without culture results. Significant pyuria is defined as  $> 10$  WBC/cu mm. Pyuria however, is not diagnostic of UTI. Also the absence of pyuria, particularly in children with recurrent UTI does not exclude significant bacteriuria.

However, an active infection can be present in the child upon the presence of a clean catch or suprapubic bladder urine (SPA) in an infant or a mid stream specimen urine (MSSU) in an older child of a growth of more than 100,000 ( $10^5$ ) Colony forming units of pathogenic organisms per ml or any growth on SPA sample is significant.

### Course and Prognosis

In the majority of cases of acute UTI complete recovery occurs with adequate treatment. A proven UTI in any child is an indication for further investigation. They may include plain radiograph, ultrasonography, intravenous urography, micturating cystography and gamma camera renography,  $^{99}\text{Tc}$  diethylene triamine pentaacetic acid (DTPA) and dimercaptosuccinic acid (DMSA) renal scans. Their use should be tailored to the clinical situation in each case. Box 17.4 shows basic learning points.

#### Box 17.4: Basic learning points

Ultrasound is the most sensitive method for detection of renal parenchymal damage and for evaluation of differential renal function.

DMSA scan is very sensitive for the detection of renal scarring damage, the evaluation of divided renal function (normal if it lies between 45% and 55%), assessment of ectopic renal tissue, assessment of suspected horseshoe kidney and investigation of a child with hypertension.

Micturating cystourethrogram (MCUG) is the definite method for detecting the bladder and urethral anatomy.

DTPA is the indirect radionuclide cystography but the child should be toilet trained (3–3½ years of age).

Uses are assessment of reflux, assessment of obstruction.

$^{99\text{m}}\text{Tc}$ -mercapto-acetylglycyl-glycyl-glycine ( $^{99\text{m}}\text{Tc}$ -MAG3) is non-invasive technique for the follow-up of vesicoureteric reflux (VUR) previously assessed by MCUG.

### Management

General nursing measures include a large fluid intake, antipyretic agents when there is high fever and a laxative if the patient is constipated. If at all possible antibiotic therapy should not be commenced until the diagnosis has been fully established or at least appropriate urine cultures have been obtained so that the organism and its antibiotic sensitivity

can be determined. However, in any unwell child especially in infants and children under the age of 2 years, it would be unwise to withhold antibiotic once urine cultures have been taken and treatment should be started with the "best guess" antibacterial agent in full dosage. Full dose antibacterial therapy is given for 7–10 days. However, if there is no clinical response within 24–48 hours, the antibiotic should be changed. At present the following drugs are suitable for administration for UTI.

### Child under Three Months of Age

Intravenous amoxicillin plus gentamicin or intravenous cephalosporin alone.

### Child over Three Months of Age

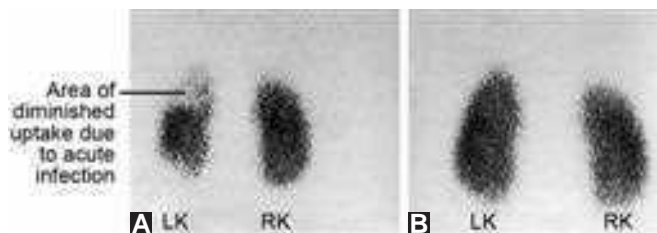
With uncomplicated lower UTI, trimethoprim or nitrofurantoin or oral cephalosporin (e.g. cefalexin) or amoxicillin should be used. Treat for 3 days. Reassess child, if unwell 24–48 hours after initial assessment. Use amoxicillin only if organism sensitive.

### Child over Three Months of Age

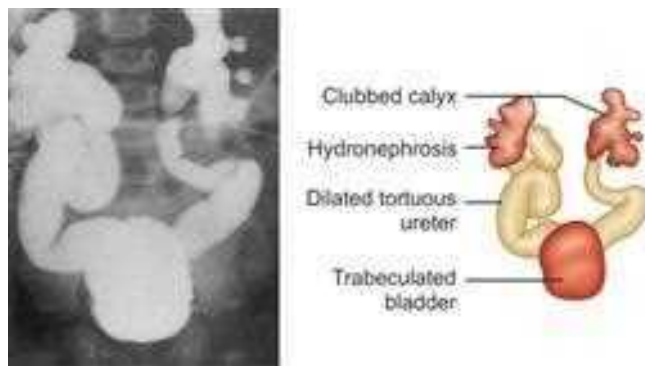
With acute pyelonephritis, a cephalosporin or co-amoxiclav should be used. Treat for 7–10 days (If oral antibiotics cannot be used, consider IV antibiotics).

To reduce the risk of dental decay, liquid preparations should be sugar free and must not be diluted with sugar containing diluents.

The long-term management of infants and children with a history of recurrent UTI, renal scarring (Figs 17.1A and B) or other imaging abnormalities, e.g. VUR (Fig. 17.2) should be tailored to the individual patient. However, it would seem appropriate to maintain patients with definite risk factors on some form of antibiotic prophylaxis until the age of 5 years. Otherwise no routine follow-up is required but awareness of the possibility of recurrence and the need to be vigilant and to seek prompt treatment if UTI is suspected.



**Figs 17.1A and B:** (A) <sup>99m</sup>Tc DMSA scan showing an area of reduced uptake of the scanning agent in the upper part of the left kidney at the time of an acute urinary tract infection. The function in the kidney was also reduced. (B) The appearance had returned to normal on a follow-up scan



**Fig. 17.2:** Cystogram showing bilateral vesicoureteric reflux

## Urinary Tract Imaging

A significant number of urinary tract anomalies will be detected in children of both sexes who present with UTI. Therefore all children should have some urinary tract imaging after a first UTI (Box 17.5). Children with UTI should undergo ultrasound (within 6 weeks) only if they are younger than 6 months or have had recurrent infection. No other investigations are indicated for any child with UTI unless they have recurrent UTI and/or abnormality on ultrasound. Recurrent UTI is defined as follows:

- Two or more episodes of UTI with acute pyelonephritis/upper urinary infection or
- One episode of UTI with acute pyelonephritis/upper urinary infection plus one or more episode of UTI with cystitis/lower UTI or
- Three or more episodes of UTI with cystitis/lower UTI.

### Box 17.5: Urinary tract imaging

#### Initial

##### 0–1 years

Urinary tract ultrasound, <sup>99m</sup>Tc DMSA scan and MCUG; MCUG scan should be carried out when the urine is sterile and should be carried out if there is gross dilatation of the collecting system and/or obstructive uropathy is suspected.

##### 1–5 years

Urinary tract ultrasound and <sup>99m</sup>Tc scan; if there is a history of recurrent UTI, or a family history of VUR/reflux nephropathy. If an abnormality on either of these two imaging studies is found, a reflux study should be done. (A) In a pre-continent child—MCUG or a direct isotope cystography (B) In a continent and cooperative child; <sup>99m</sup>Tc DTPA or MAG3 scan.

##### > 5 years

Urinary tract ultrasound alone unless there is a history of recurrent UTI or a family history of VUR/reflux nephropathy, a <sup>99m</sup>Tc DMSA scan should be done. If an abnormality is detected on either of these two imaging studies then a <sup>99m</sup>Tc DTPA or MAG3 indirect radionuclide cystogram should be considered.

#### Follow-up

Subsequent imaging should be individualised, depending upon the age of the child and the presence or absence of abnormalities on initial imaging.

**Case Study**

A six-month-old girl presented with fever (38°C), irritability, listlessness, vomiting and not finishing her feeds. On examination she looked ill and pale. Otherwise she had no positive finding. Hb 8.6 g/dl, WBC  $16 \times 10^9/L$  (neutrophils  $12 \times 10^9/L$ ), platelet count normal, CRP 98 mg/L. Urine; blood 2+ and protein 2+, pus cells  $200/mm^3$ . CSF sterile on culture. Blood and urine cultures yielded a heavy growth of *E.coli*. Urinary tract ultrasound normal. She responded to a course of intravenous cefotaxime 100 mg/kg for 7 days satisfactorily.

*Diagnosis:* *E. coli* septicaemia with UTI

**Haematuria**

Unless there is an obvious lesion of the prepuce or meatus, haematuria is always of serious significance. Table 17.2 shows the differential diagnosis of haematuria in children. Fear on the part of the parents usually leads to early investigation of haematuria. Haematuria may also be accompanied by pain when there is passage of a blood clot. Painless haematuria may be a presenting feature in many children with glomerulonephritis and in rare instances of Wilms tumour. In

**Table 17.2:** Differential diagnosis of paediatric haematuria

1. Glomerular
  - a. Acute post-streptococcal glomerulonephritis
  - b. Henoch-Schönlein purpura
  - c. IgA nephropathy
  - d. Systemic lupus erythematosus (lupus nephritis)
  - e. Haemolytic uraemic syndrome
  - f. Shunt nephritis
  - g. Hereditary nephritis (Alport syndrome)
2. Urinary tract
  - a. Urinary tract infection
  - b. Haemorrhagic cystitis
  - c. Renal calculi
  - d. Urinary schistosomiasis
3. Vascular
  - a. Sickle cell disease
  - b. Renal vein thrombosis
  - c. Thrombocytopenia
4. Interstitial
  - a. Renal tuberculosis
  - b. Cystic disease
  - c. Hydronephrosis
  - d. Wilms' tumour
  - e. Acute tubular necrosis
  - f. Drugs, e.g. NSAIDs, chemical cystitis (cyclophosphamide), etc.
  - g. Factitious

the new-born haematuria may be the presenting sign of renal vein thrombosis. Trauma may produce frank blood in the urine and minor trauma which causes haematuria suggests an underlying lesion such as hydronephrosis. Also haematuria can occur in general diseases such as thrombocytopenic purpura and leukaemia. There are certain substances including medications which can alter the colour of urine and thus simulate gross haematuria (see Box 17.1).

As regards the diagnosis, microscopic urinalysis is simple yet vital in distinguishing glomerular from non-glomerular sources of bleeding. Macroscopic haematuria is such an alarming occurrence for parents that prompt investigation is indicated. The urgency is less with microscopic haematuria and it is usual to document its presence over at least one month before embarking on further evaluation. Early and appropriate diagnosis of haematuria results in improved clinical outcomes. In a few children with haematuria no firm diagnosis is made. A scheme for investigation of paediatric haematuria is shown in Figure 17.3.

**Key Learning Point**

- ➔ Urinary tract infection is the common cause of macroscopic (frank) haematuria.

**RENAL TUBERCULOSIS**

Symptomatic tuberculosis of the kidney and urinary tract is uncommon in children. Most cases of renal tuberculosis have evidence of concomitant, usually pulmonary tuberculosis, which is frequently inactive. The interval between primary tuberculosis and development of active renal tuberculosis could take a very long time, e.g. 5–15 years.

Clinical presentation consists of dysuria, frequency of micturition, flank pain and occasionally gross haematuria. Sterile pyuria is typical of renal tuberculosis. Tuberculin test is positive. Positive culture of three morning urine specimens for mycobacteria will establish the diagnosis. Standard anti-tuberculous therapy is recommended.

**HYPERTENSION IN CHILDREN**

The incidence of hypertension in children is thought to be somewhere between 1% and 3%. In children most cases of hypertension are of secondary aetiology. Also in the younger hypertensive patient it is more likely that the hypertension is due to a correctable disorder. About 80–90% of cases of severe or sustained hypertension in children are due to some form of renal disease. Causes of hypertension in children are as outlined in Table 17.3. A diagnosis of essential hypertension can be made only after exclusion of all other known causes of hypertension. It is

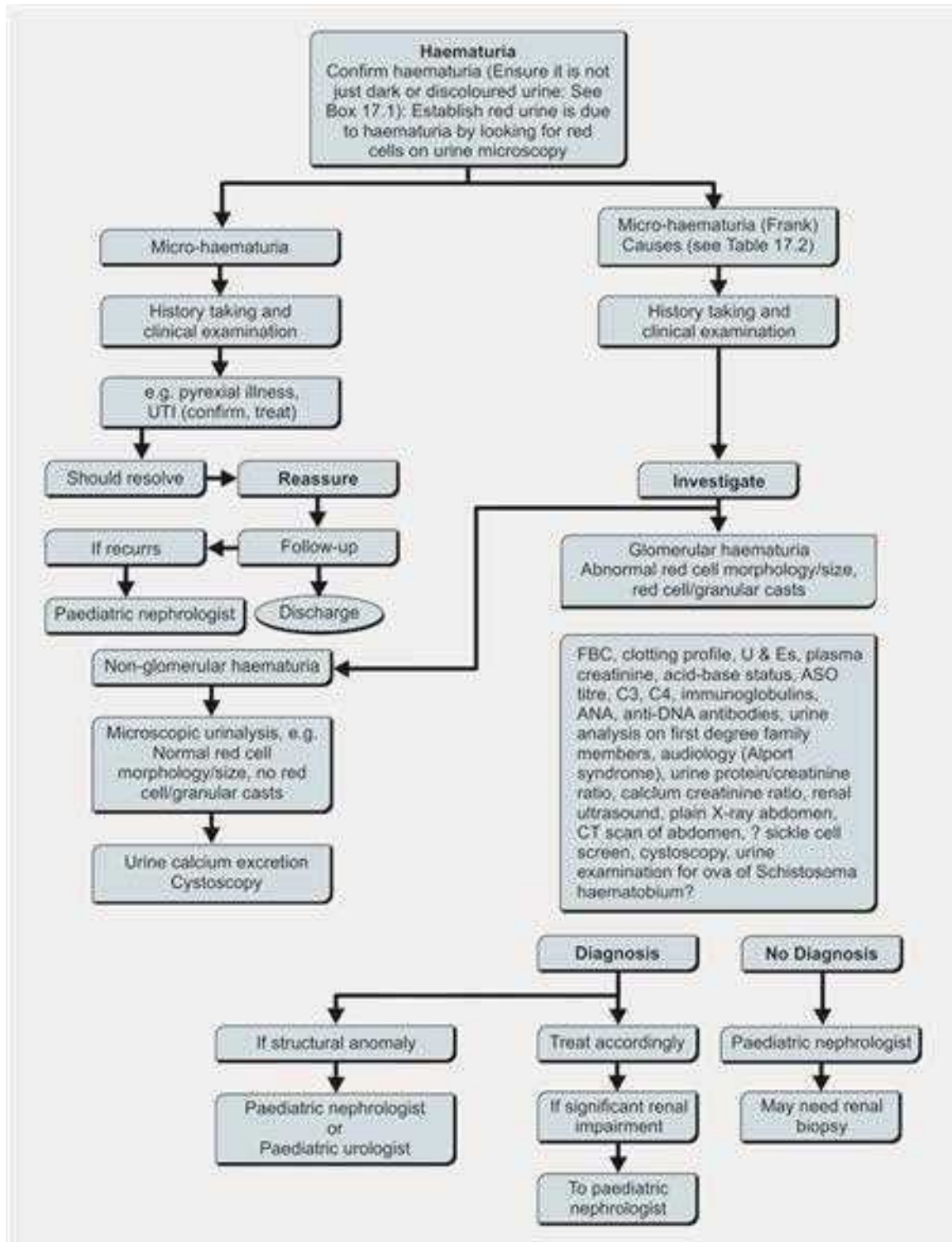


Fig. 17.3: A plan for the investigation of paediatric haematuria (Redrawn from chapter one, Fig 1:3, Haematuria by SR Meadow, in Clinical Paediatric Nephrology, second edition, 1994, Butterworth Heineman, Elsevier.

**Table 17.3:** Causes of hypertension in infants and children

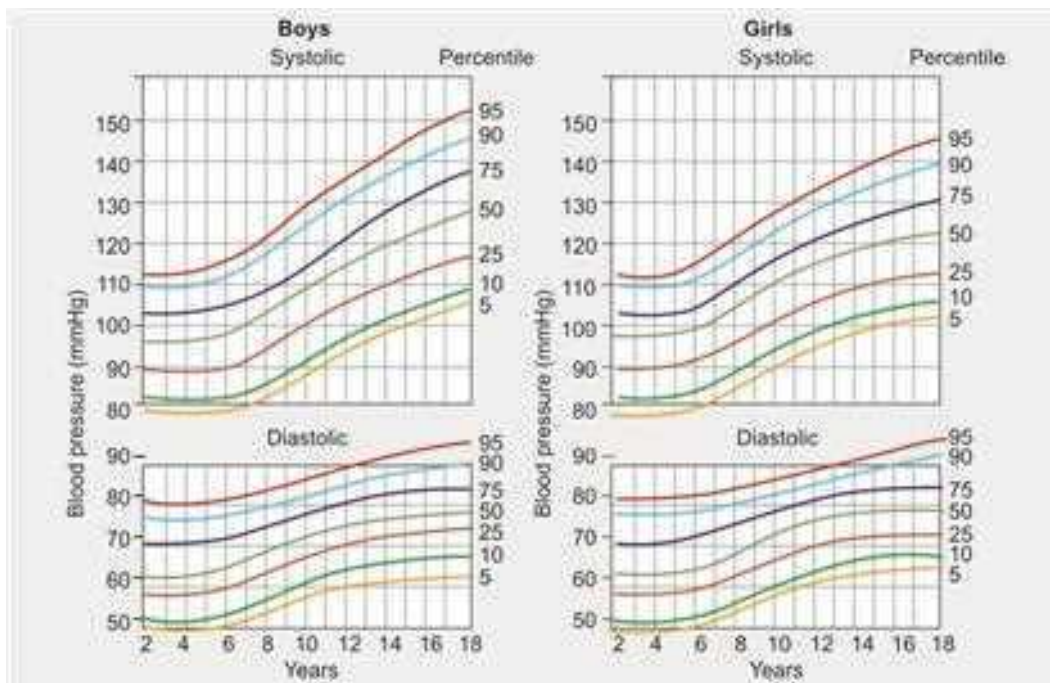
1. Renovascular disease
  - Renal artery stenosis
  - Renal artery aneurysm
  - Renal artery thrombosis
  - Polyarteritis nodosa
2. Renal parenchymal disease
  - Chronic glomerulonephritis
  - Polycystic disease of kidneys
  - Haemolytic uraemic syndrome
  - Reflux nephropathy
  - Obstructive uropathy
  - Chronic renal failure
3. Renal tumours
  - Nephroblastoma
  - Pheochromocytoma
  - Neuroblastoma
4. Congenital adrenal hyperplasia
5. Conn and Cushing syndrome
6. Essential hypertension
7. Drugs: Corticosteroid therapy (iatrogenic)
8. Coarctation of aorta

commonly found in obese children. Serious hypertension is rare in neonates but it can present with signs of congestive cardiac failure, the cause is often renal and can follow embolic arterial damage.

As shown in Figure 17.4, normal blood pressure readings vary according to the age of the child. The most reliable definition is a systolic or diastolic blood pressure above the 95th centile of the expected blood pressure for the child's age, which is confirmed on at least two measurements. Blood pressure levels below the 90th centile are normal. The "gold standard" for blood pressure measurement is mercury sphygmomanometry or Doppler ultrasound method and these should be used to confirm hypertension found using automated devices.

### Clinical Features

Children with quite severe hypertension may be asymptomatic and hypertension is usually detected on routine physical examination. The most common symptoms are headache, nausea, vomiting, polyuria, polydipsia and abdominal pain. Needless to say, blood pressure measurement is essential in a child with headache, in spite of the fact that there is a strong family history of migraine. Some children may present with convulsions, epistaxis, visual disturbances and facial palsy. Symptoms related to catecholamine excess, such

**Fig. 17.4:** Normal blood pressure values in children



as palpitations, sweating and weight loss may suggest the presence of a pheochromocytoma.

Physical examination should include careful inspection of optic fundi for evidence of hypertensive retinopathy. Other important findings that suggest renovascular hypertension are cardiomegaly and the presence of an upper abdominal bruit. Physical examination should also include a neurological evaluation, palpation of the abdomen for a mass and inspection of skin for café-au-lait spots, neuromas and neurofibromas. Cushingoid features or evidence of virilisation suggest disturbances of adrenocortical function. Upper limb hypertension associated with delayed or absent femoral pulses suggest the diagnosis of coarctation of aorta.

### Investigation of Hypertension

It is vital to remember that single high blood pressure values are not reliable. All children with persistent hypertension should have some evaluation but the question arises how intensive it should be; laboratory investigations should include FBC, CRP, U and E's, creatinine, LFT's, routine urinalysis, urine culture, chest X-ray, ECG, and echocardiography. If renal aetiology is suspected; renal imaging such as renal ultrasound with Doppler, DMSA and DTPA renal scans, intravenous urography, renal angiography and renal biopsy. If catecholamine excess suspected; CT/MRI imaging of abdomen, abdominal angiography with selective venous sampling.

If corticosteroid excess suspected; urinary steroid profile, steroid suppression tests, adrenal CT/MRI and selective adrenal venous steroid sampling.

### Management of Hypertension

Main indications for antihypertensive therapy in children include symptomatic hypertension, secondary hypertension, hypertensive target-organ damage and persistent hypertension despite life style measures. Most children with hypertension will require general advice regarding diet, exercise and lifestyle i.e. reduction of dietary salt, reduction of total and saturated fat, increasing exercise, increasing fruit and vegetable intake and not smoking.

In children with retinopathy, encephalopathy, seizure or pulmonary oedema immediate steps should be taken to lower the blood pressure. Therefore they may need intravenous anti-hypertensive therapy initially. Drugs that can be used belong to five categories, which are most suitable for the first line treatment of children with hypertension. These are diuretics, adrenoceptor blockers, angiotensin-converting enzyme (ACE) inhibitors, calcium antagonists and vasodilators. Other classes of drugs may be used in certain situations (Box 17.6). Ideally, antihypertensive

therapy should be initiated with a single drug at the lowest recommended dose; the dose can be increased until the desired blood pressure is achieved. Once the highest recommended dose is reached, or sooner if the patient begins to experience side-effects, a second drug may be added if blood pressure is not controlled. If more than one drug is required, these should be given as separate products to permit dose adjustment of individual drugs.

#### Box 17.6: Antihypertensive drugs in children aged 1 month–12 years

1. Diuretics
  - Furosemide: 0.5 mg/kg orally 2–3 times a day or 0.5 to 1 mg/kg IV repeated every 8 hours as necessary
  - Spirolactone: 1–3 mg/kg/d orally in 1–2 divided doses
2. ACE inhibitors
  - Captopril: 0.3 mg/kg/d orally in 3 divided doses
  - Enalapril: 0.1 mg/kg/d orally in 1–2 divided doses
3. Calcium channel blockers
  - Nifedipine: 0.25 mg/kg/d orally in 1–2 divided doses
  - Amlodipine: 0.05 mg/kg/d once daily
  - Nimodipine, Verapamil, Nicardipine and Diltiazem (dosage according to national formulary)
4. Adrenergic blockers
  - Labetalol: 1–3 mg/kg/hour intravenously (infusion only)
  - Atenolol: 1 mg/kg/d orally in one dose
5. Vasodilators
  - Hydralazine: 0.15–0.25 mg/kg/dose IV repeated every 4–6 hours as necessary
  - Minoxidil: 0.2 mg/kg/d in 1–2 divided doses
  - Sodium nitroprusside (in hypertensive emergencies)
    - Mild Hypertension (use one of the following)
      - Nifedipine, Amlodipine and Atenolol
    - Moderate Hypertension (use one of the following)
      - Nifedipine, Amlodipine, Atenolol and Enalapril
    - Severe Hypertension (use one of the following)
      - Nifedipine, Amlodipine, Atenolol and Enalapril

### Hypertensive Emergencies

Hypertensive emergencies in children may be associated with signs of hypertensive encephalopathy, including seizures. Controlled reduction in blood pressure over 72–96 hours is essential. Treatment should be commenced with intravenous drugs; once blood pressure is under control, oral therapy can be commenced. Controlled reduction of blood pressure is obtained by intravenous administration of labetalol or sodium nitroprusside.

#### Key Learning Points

##### Blood Pressure Check

- ➡ Blood pressure should be routinely measured in a child at least on the first paediatric consultation
- ➡ Children who are at risk of developing hypertension, e.g. with known renal disease, must have their blood pressure checked routinely.

## RENAL VEIN THROMBOSIS

Renal vein thrombosis is a microvascular angiopathy which used to occur more frequently in dehydrated and seriously ill infants. The intravascular coagulation spreads from within the intrarenal vessels into the larger veins and ultimately to the renal vein. In an ill infant the appearance of gross proteinuria, haematuria and an enlarged kidney suggest the diagnosis. The baby may also have significantly raised blood pressure. The colour Doppler ultrasound will be useful in making the diagnosis of renal venous thrombosis. Supportive therapy with re-establishment of an adequate circulating volume is most important and treatment of any primary underlying disorder is indicated.

## RENAL CALCULI (UROLITHIASIS)

### Aetiology

There are three main types of renal calculi in children, i.e.

1. Endemic
2. Infective
3. Metabolic.

The great majority of renal calculi found in children are secondary to infection of the renal tract, especially by urea-splitting *Proteus vulgaris*, which by maintaining a high urinary pH favours the deposition of phosphate in combination with calcium, ammonium and magnesium. The typical "staghorn" calculus fills the renal pelvis and calyces (Fig. 17.5). Calculus formation is especially when there is an obstruction in the renal tract, e.g. at the pelvi-ureteric or vesicoureteric junction. Nephrocalcinosis is the deposition of calcium salts within the renal parenchyma and it may be associated with urolithiasis. Very rarely calcium phosphate or oxalate stones are a manifestation of primary hyperparathyroidism or hypervitaminosis D. Calculi may also develop after prolonged immobilisation. Cystinuria, one of the inborn errors of metabolism, is a rare cause of renal stone formation. In this condition there is a defect



Fig. 17.5: Staghorn calculus

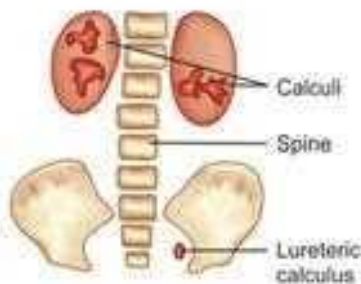


Fig. 17.6: Calculus in bladder

in the tubular reabsorption not only of cystine but also of lysine, arginine and ornithine. In spite of the passage of the typical hexagonal crystals in the urine only a minority of affected children develop calculi. This condition must not be confused with the quite separate metabolic disorder called cystinosis in which cystine is deposited in body tissues. Another exceedingly rare cause of renal lithiasis, also an inborn error of metabolism is primary hyperoxaluria. Other inherited metabolic diseases which increase the excretion of very insoluble substances and thus formation of renal stones are Lesch-Nyhan syndrome, 2, 8-dihydroxyadenineuria, xanthinuria and the orotic acidurias.

In certain parts of the world, e.g. India and other developing countries, endemic urolithiasis leads to the formation of vesical calculi, which are composed of ammonium acid urate (Fig. 17.6). There is evidence implicating dietary factors in their pathogenesis, where the major source of dietary protein is cereals instead of meat.

### Clinical Features

The majority of children present as cases of UTI with pyuria. Classical renal colic with haematuria is relatively uncommon in childhood.

### Diagnosis

Calculi cause acoustic shadows and have a characteristic ultrasound appearance; therefore renal calculi can be diagnosed by renal ultrasound examination. However, the presence of a renal calculus may be overlooked by ultrasound examination. Therefore, it can be confirmed by an abdominal X-ray and an intravenous pyelogram (IVP) may be necessary to establish calyceal anatomy prior to lithotripsy. Spiral computed tomography (CT) is the most sensitive method for diagnosing renal calculus. In confirmed cases, it is wise to determine the urinary output of calcium, cystine and oxalate so that metabolic disorders are not overlooked.

### Treatment

This consists of sterilisation of urine by appropriate antibiotic therapy and removal of the calculus either by lithotripsy or by an operation. Also percutaneous nephrolithotomy in

children before school age is a safe and effective procedure for treating renal stones.

### HYPOPHOSPHATAEMIC VITAMIN D-RESISTANT RICKETS (PHOSPHATURIC RICKETS)

In this disease rickets develops at a later age, than is usual in infantile rickets and it is resistant to vitamin D in ordinary doses. It appears to be casually related to a deficiency in the tubular reabsorption of phosphate. The disease is usually transmitted by a dominant gene on the X chromosome; affected males have only affected daughters, whereas affected females have equal numbers of affected and healthy children irrespective of sex. The condition is therefore, more common in girls, but because they have one normal X chromosome the severity of the disorder is less than in affected males. In a few cases an autosomal recessive pattern of inheritance has been reported.

#### Clinical, Biochemical and Radiological Features

The child develops the classical features of rickets modified from the vitamin D deficient infantile variety only by the patient's age. These include enlargement of epiphyses, rachitic rosary and deformities of the limbs. Bilateral coxa vara frequently results in a characteristic waddling "penguin" gait. Short stature with disproportionate shortening of the lower limbs is the most important clinical manifestation (Fig. 17.7).

Urinary excretion of calcium is small whereas the output of phosphate is excessive. The phosphate reabsorption percentage is less than 85% in spite of low plasma phosphate and parathyroid hormone (PTH) values.



Fig. 17.7: A girl with hypophosphataemic rickets showing short stature and bow legs



Fig. 17.8: X-rays of wrists and hands showing changes caused by rickets

The plasma biochemical findings in the blood are the same as those usually found in infantile vitamin D deficiency rickets, namely normal plasma calcium, reduced plasma phosphate and increased alkaline phosphatase. The plasma concentration of 25-OHD<sub>3</sub> is usually normal and that of 1,25 (OH)<sub>2</sub> D<sub>3</sub> is slightly low or normal. Aminoaciduria which is commonly found in vitamin D deficiency rickets is not a feature of hypophosphataemic rickets. Radiological features are those of rickets, e.g. cupped, frayed and broadened metaphyses, broadened epiphyses, osteoporosis, deformities and pathological fractures (Fig. 17.8).

#### Treatment

As hypophosphataemic rickets occurs due to abnormal phosphate excretion, treatment with high doses of oral phosphate and hydroxylated (activated) forms of vitamin D allow bone mineralization and optimize growth. Vitamin D is not a single entity but a group of substances with a specific pattern of activity, such as ergocalciferol (vitamin D<sub>2</sub>) and cholecalciferol (naturally occurring vitamin D<sub>3</sub> produced by ultraviolet (UV) light acting on 7-dehydrocholesterol in the skin). Vitamin D<sub>2</sub> and D<sub>3</sub> are equal in potential potency but are precursors and two metabolic steps are required to produce active enzymes (Fig. 17.9). The first is in the liver, the second in the kidney. The most effective treatment appears to be a combination of 1–4 g of oral elemental phosphate/day with either oral 1,25 (OH)<sub>2</sub> D<sub>3</sub> initially 15 nanograms (ng)/kg once daily, increased if necessary in steps of 5 ng/kg daily every 2–4 weeks (maximum 250 ng) or 1 α-OHD<sub>3</sub> 25–50 ng/kg once daily, adjusted as necessary [maximum 1 microgram (μg)]. Initially phosphate supplementation may cause diarrhoea but tolerance to the regimen usually develops within 1–2 weeks. Frequent estimations of plasma calcium are necessary to detect hypercalcaemia due to overdosage. Vitamin D therapy alone rarely corrects dwarfism and even if started in early infancy may fail to prevent its development. Patients with residual skeletal deformities may need surgical

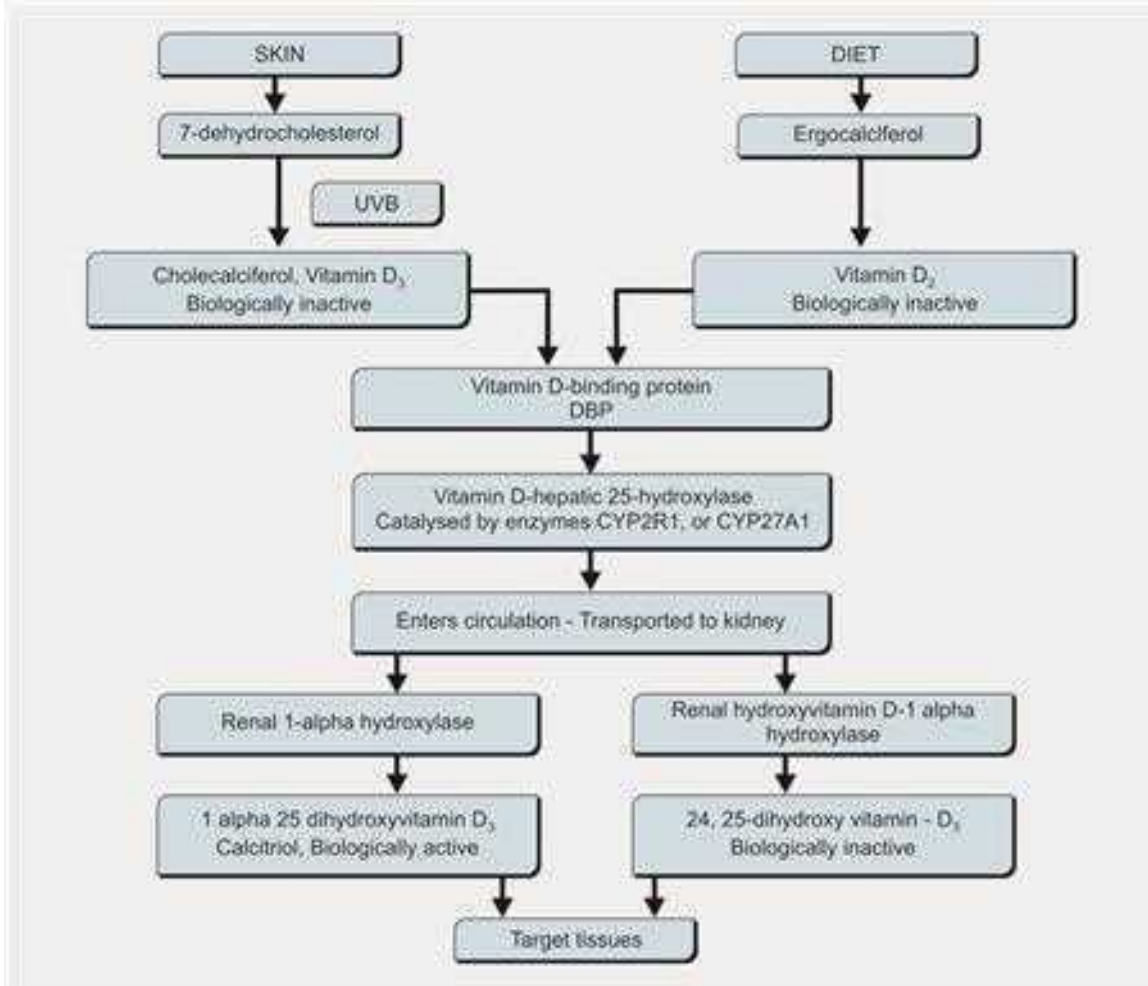


Fig. 17.9: Metabolism of vitamin D

correction with bilateral tibial and femoral osteotomies, usually after growth has ceased.

#### Case Study

A 5-year-old boy presented to the paediatric clinic with bilateral bowing of the legs. The child was of Scottish origin, had a normal diet and no gastrointestinal symptoms. On examination he had short stature, reduced dental enamel and bilateral varus deformity of the knees. He did not have any wrist swelling.

Investigations performed were:

- Ca 2.31 mmol/L (reference range 2.2–2.7 mmol/L)
- Po<sub>4</sub> 0.56 mmol/L (reference range 0.9–1.8 mmol/L)
- PTH 8.5 pmol/L (reference range 0.9–55 pmol/L)
- 25HCC 74 nmol/L (reference range 15–85 nmol/L)
- Phosphate excretion index high
- Tubular reabsorption rate of phosphate low: <85% (normal 85–95%)

*Diagnosis:* Hypophosphataemic rickets

## RENAL FANCONI SYNDROME (CYSTINOSIS)

This syndrome embraces a group of biochemical disorders resulting from multiple renal tubular defects; glycosuria, aminoaciduria, tubular acidosis, phosphaturia, potassium loss and occasionally sodium loss and uricosuria. Cystine crystals are found throughout the reticuloendothelial system but there is no gross excretion of cystine in the urine as in cystinuria which is a quite separate inborn error of metabolism. The disease is inherited as an autosomal recessive trait.

### Clinical Features

The physical features usually appear in early infancy and resemble those of hyperchloraemic acidosis. The features, failure to thrive, anorexia, vomiting and severe constipation are constantly present. Thirst and polyuria may also have been noted by the mother. A feature characteristic of cystinosis is photophobia. This is due to the presence of cystine crystals



**Fig. 17.10:** Rachitic rosary and generalised wasting

in the cornea but it is not always present. Rickets makes its appearance after some months of illness. Its appearance in a wasted infant is in contrast to infantile rickets which is more commonly found in well grown infants (Fig. 17.10).

### Diagnosis

This is based initially on the presence of glycosuria and aminoaciduria. Radiological changes are typical of rickets. Cystinosis can be confirmed by the detection of cystine crystals in the cornea with a slit-lamp, or by finding them in bone marrow or lymph node biopsy material. White cell cystine levels are raised and this is now used in diagnosis and monitoring treatment.

### Treatment

The rickets requires large doses of calciferol for healing (50,000–300,000 units daily). Alternatively 1 alpha OHD (1 alpha-hydroxycholecalciferol) may be used in the dosage of 25–50 ng/kg once daily orally. The metabolic acidosis can be corrected with oral sodium bicarbonate 1–3 mmol/kg/d. If hypokalaemia is present some of the sodium salt should be replaced by potassium citrate or potassium bicarbonate. The daily intake of potassium salt may need to be as much as 5 g. Mercaptamine (cysteamine) is available for the treatment of nephropathic cystinosis. Mercaptamine eye drops are used in the management of ocular symptoms arising from the deposition of cystine crystals in the eye. Renal transplantation has been successful in children with cystinosis who develop end-stage renal disease.

#### Case Study

A 2-year-old Asian boy presented with a history of “not growing” and polydipsia. Parents were first cousins. His height was between the 0.4th–2nd centile and weight between the 2nd–9th centile. He had widening of both wrists. No other positive finding.

Investigations performed; Hb 10.4 g/dl, WBC 7.2 x 10<sup>9</sup>/L, platelets 315 x 10<sup>9</sup>/L, plasma sodium 130 mmol/L, potassium

2.9 mmol/L, chloride 94 mmol/L, bicarbonate 28 mmol/L, urea 5.6 mmol/L, creatinine 115 micromol/L, calcium 2.26 mmol/L, phosphate 0.87 mmol/L, alkaline phosphatase 315 u/L, parathormone (PTH) 9.3 pmol/L (reference range 0.9–5.5 pmol/L), 25HCC 64 nmol/L (normal), leucocyte cystine 4.26 nmol of ½ cystine/mg of protein (normal < 0.3 nmol of ½ cystine/mg of protein).

*Diagnosis:* Nephropathic cystinosis

## NEPHROGENIC DIABETES INSIPIDUS

Nephrogenic diabetes insipidus (NDI) is a rare condition which must be differentiated from central-neurogenic or pituitary diabetes insipidus (CDI) due to failure of production by the posterior pituitary of antidiuretic hormone (ADH). In NDI the renal tubules fail to respond to vasopressin and reabsorb water normally. The condition has been transmitted as an X-linked trait in most of the reported families, only males being affected. The concentrating defect can be partial or complete.

### Clinical Features

Excessive thirst and polyuria start soon after birth. Failure to thrive, anorexia, constipation and vomiting are common. Deprivation of fluids or a high environmental temperature leads to fever, prostration and hypernatraemic dehydration because these children cannot produce urine of high specific gravity. There is a particular risk during infancy when the patient is unable to determine his/her own fluid intake. Usually the child is non-selective in his choice of fluids and they wake from sleep to drink and may drink from inappropriate sources e.g. toilet cistern and bath water or any other source of fluid available. Another clinical feature is that growth may also be retarded.

### Diagnosis

Diagnosis can be confirmed by the failure to respond to vasopressin (vasopressin test) and by the marked inability to concentrate the urine during water deprivation (a urine osmolality estimated 4 hours later-normal response is a urine osmolality of over 800 mOsm/kg).

In NDI benefit may be gained from the paradoxical anti-diuretic effect of thiazides, e.g. chlorothiazide 10–20 mg/kg twice daily (maximum 500 mg).

#### Key Learning Points

##### Vasopressin Test

- ➔ In NDI there is little change in pre- and post-vasopressin urine osmolality
- ➔ In CDI the pre-vasopressin test osmolality is less than 300 mOsm/kg, but post-vasopressin urine osmolality is markedly increased i.e. more than 800 mOsm/kg.

**Case Study**

A 3-month-old boy was born at 38 weeks gestation with a birth weight of 3 kg. Neonatal period was uneventful. He was bottle-fed. He was irritable, took his bottle feeds satisfactorily. Milk offered to him was never enough and was always thirsty—so he was offered flavoured water which he took eagerly. His weight gain was poor. On examination he was well hydrated. In fact he had no positive finding. Urine dipstick and culture negative. Urinary tract ultrasound was normal. Plasma urea 12 mmol/L, sodium 164 mmol/L and creatinine 60  $\mu$ mol/L. He was given DDAVP 0.5  $\mu$ gram intranasal and urine osmolality 4 hours later was 200 mOs/kg.

*Diagnosis:* Nephrogenic diabetes insipidus

**RENAL TUBULAR ACIDOSIS**

Two main mechanisms are recognised in renal tubular acidosis (RTA). In one mechanism in the presence of systemic acidosis the kidney is unable to excrete sufficient hydrogen ions to lower the urinary pH below 6. This mechanism is responsible for the classical or distal RTA (type 1). In this type giving an ammonium chloride load fails to depress urinary pH below 6.0 and the excretion rates of ammonium and titratable acid are reduced. In the other mechanism, operative in proximal renal tubular acidosis (type 2) the proximal tubule is unable to conserve filtered bicarbonate adequately or in other words there is bicarbonate wastage. In this type 2 RTA the response to ammonium chloride loading test is normal. Type 3 is a mixture of distal and proximal RTA and type 4 is associated with a deficiency of aldosterone production or resistance to its action (pseudohypoaldosteronism).

**Distal Renal Tubular Acidosis (Type 1 RTA)**

Primary distal renal tubular acidosis is usually sporadic but can be inherited as an autosomal dominant trait.

The classical disorder occurs more frequently in girls and usually presents after the age of 2 years with polyuria and polydipsia. Muscular weakness and flaccid paralysis may result from hypokalaemia. Often the initial manifestation of the disease is growth failure.

Laboratory findings consist of hyperchloraemic metabolic acidosis and failure of urinary pH to fall below 6 even in the presence of severe metabolic acidosis. Renal potassium loss is reflected in the persistent hypokalaemia.

Secondary distal renal tubular acidosis can occur in children with vitamin D intoxication, obstructive uropathy, medullary sponge kidney, Marfan syndrome and after renal transplantation.

**Treatment**

Treatment is aimed at correcting the metabolic acidosis by using sodium bicarbonate 1–3 mmol/kg/d. Potassium supplementation may also be required to correct the hypokalaemia. Striking improvement in growth can be expected with this regimen.

**Proximal Renal Tubular Acidosis (Type 2)**

The primary and secondary forms of proximal renal tubular acidosis are rare; therefore they will not be discussed in this chapter.

**NOCTURNAL ENURESIS**

Enuresis refers to the persistent involuntary or inappropriate voiding of urine. This can occur while the child is asleep (nocturnal) or in the daytime (diurnal). The disorder may have been primary or come on at a later stage secondary. Primary (continuous) enuresis is the sleep wetter who has never been dry for extended periods. Whilst secondary enuresis is the onset of wetting after a continuous dry period of at least 6 months.

Nocturnal enuresis is a commonly occurring disorder which affects approximately 10% of children at the age of 5 and 5% at the age of 10 years with 1 or 2% continuing to wet throughout the teens. Enuresis is seen worldwide in all cultures and races. It is crucial that parents understand that the child is not wetting the bed on purpose and that the enuresis is not voluntary. Therefore punitive measures should not be used in the management of bedwetting.

Nocturnal enuresis is not primarily a child psychiatric problem and it occurs with similar prevalence as all the rest of the psychiatric disorders put together. There is frequently a family history and it is usually a mono-symptom with family discord and emotional factors being secondary to the inconvenient and undesirable symptom. There is an increased incidence of wetting amongst populations of children with child psychiatric problems, but the correlation is not with any specific disorder. While it is assumed enuresis is associated with anxiety, it more often occurs in children in poor social circumstances where early training has not been established. Some children have had disturbing life events at the time when night-time bladder control should be acquired and the symptom is more frequent in children with other developmental delays and with encopresis, one mechanism being that the faecal impaction fills the space occupying the pelvis and presses on the bladder neck, giving rise to incomplete voiding of urine.

Associated urinary tract problems and other medical problems are unusual but should be kept in mind when a new

case is seen. Structural anomalies such as reflux into mega-ureters are associated with incomplete bladder emptying and a reduction in the amount of urine voided at any time. Although it is easy to test for UTI, most children with UTI do not bed-wet and most bed-wetters are not infected. Children with mono-symptomatic nocturnal enuresis are unlikely to have an organic cause. The physical examination results in almost all children with nocturnal enuresis are completely normal. However, urine should be tested both biochemically and bacteriologically. However, children with daytime frequency, urgency, wetting, dysuria and abdominal straining or poor urinary stream, may indicate the presence of a bladder disorder such as overactive bladder or rarely an underlying urological disease.

**Key Learning Point**

► Children with mono-symptomatic nocturnal enuresis are unlikely to have an organic cause.

**Treatment**

Treating enuresis can be frustrating for the parents, the child and the paediatrician. Parents should be firmly reassured that the problem of bed-wetting may resolve with time and that these children are not at fault for wet episodes. Children are generally expected to be dry by a developmental age of 5 years and historically it has been common practice to consider children for treatment only when they reach 7 years. Therefore treatment is not appropriate in children under 5 years and it is usually not needed in those aged 7 years and in cases where the child and parents are not anxious about the bed-wetting. Drug therapy is not usually appropriate for children under 7 years of age. However, it can be used on a short-term basis, for example, to cover periods away from home (for example, for a sleep-over).

Tricyclics such as imipramine and rarely amitriptyline and nortriptyline are used but behaviour disturbances may occur and relapse is common after withdrawal. Tricyclics should not be used as the first-line treatment for bed-wetting in children and should be considered only if they have not responded to an alarm/or desmopressin. Treatment should not normally exceed 3 months and toxicity following overdose with tricyclics is of particular concern.

Antidiuretic hormone, in the form of desmopressin is available. It may be given by mouth or by sublingual administration. Particular care is needed to avoid fluid overload and treatment should not be continued for longer than 3 months without stopping it for a week for full reassessment. Desmopressin should not be given intranasally for nocturnal enuresis due to an increased incidence of side-effects.

The most effective treatment is the pad and buzzer—an enuresis bell, for well-motivated children aged over 7 years. Great care is needed in securing the cooperation of the child, the parents and the siblings. The alarm initially acts as a stimulus that awakens the child when micturition occurs. Ideally the child then awakens, inhibits voiding, gets out of bed and goes to toilet to complete voiding. With time the alarm creates a conditional response in which the physiologic stimuli that cause micturition cause inhibition of voiding and awakening. Attention to detail is important so that false alarms caused by inadequate cleaning of the pad, excess sweating or the pad folding over on itself should be avoided. If there is no response after 3 months, it is better to withdraw the enuresis bell. It has been reported that between 40–70% children respond to this device. Also use of an alarm may be combined with drug therapy if either method alone is unsuccessful. An alternative type of alarm (e.g. vibrating alarm) should be considered for the treatment of bed-wetting in children who have a hearing impairment. However, an alarm is considered inappropriate, especially if bed-wetting is very infrequent (i.e. less than 1–2 wet beds/week) and parents are having emotional difficulty coping with the burden of bed-wetting.

The simple technique of "lifting and waking" a child when the parents go to bed sometimes solves the problem at a practical level. The use of star charts should be reserved for those children who wish to fill them in. All too often there is an expectation that the star chart will work and if it does not there is loss of face for the child, the parent or the doctor. In fact reward systems with positive rewards for agreed behaviour rather than dry nights should be used either alone or in conjunction with other treatments for bed-wetting e.g.

- Drinking recommended levels of fluid during the day and to avoid caffeine-based drinks
- Using the toilet to pass urine before sleep
- Engaging in management (e.g. taking medication or helping to change sheets).

Therefore a set treatment package for enuretic children should be avoided. It is essential to check out the feelings, attitudes and family relationships before deciding whether a family therapy or psychodynamic approach is needed before using the pad and bell technique. Nocturnal enuresis associated with daytime symptoms (overactive bladder) can be managed by antimuscarine drugs such as Oxybutynin hydrochloride, with the addition of desmopressin if necessary. However, do not use desmopressin in the treatment of children who only have daytime wetting. There is very little evidence about the efficacy of many complementary therapies (acupuncture and hypnotherapy) and/or alternative medicine (CAM) as a treatment option when conventional treatment fails or in order to avoid drug or other treatments.

**Case Study**

An 8-year-old boy presented with a history of bed-wetting for 2 years. There was no history of daytime wetting. His father used to wet his bed but stopped wetting at the age of 12 years. On examination no positive finding was detected, in particular examination of lumbosacral spine, lower limbs and perineum was normal.

Urine was clear both biochemically and bacteriologically. Urine concentrating ability normal.

He did not respond to oral desmopressin 200 µg at bedtime daily for 3 months. However, he responded to an enuresis alarm after being on it for 2 months. His wetting did not return when seen for review 6 months later.

*Diagnosis:* Secondary nocturnal enuresis

**Key Learning Point****Nocturnal Enuresis**

➔ Drug therapy is not usually appropriate for children under 7 years of age. An enuresis alarm should be the first-line treatment for well-motivated, well supported children aged over 7 years because alarms have a lower relapse rate than drug treatment when discontinued. Use of an alarm can be combined with drug therapy if either method alone is unsuccessful.

## HAEMOLYTIC URAEMIC SYNDROME (D+HUS, D-HUS)

Haemolytic uraemic syndrome (HUS) is much commoner in infants and children than in adults. Also this condition accounts for most children with primary acute renal failure (ARF) requiring specialist renal care. The cascade leading from GI infection to renal impairment is complex. It is characterised by the triad of microangiopathic haemolytic anaemia, thrombocytopenia and ARF. There are two subtypes of HUS. The first is associated with diarrhoeal prodrome (D+HUS) and the second is not associated with antecedent diarrhoea (D-HUS).

The association between haemolytic uraemic syndrome (D+HUS) and enteric *E. coli* type 0157:H7 shows that this is the type responsible for HUS. It produces cytotoxin active on vero-cells called "verotoxin". It is usually transmitted by ingestion of contaminated food or water and by person to person contact. Also the association of shigellosis with HUS is well established. However, the incidence of HUS in India has declined with the decline in the virulent form of shigella dysentery.

The D-HUS is much rarer in childhood. The D-HUS is atypical, seen in older children and can be familial, drug induced or recurrent.

**Clinical Features**

It is characterised by abdominal cramps, watery diarrhoea changing to bloody diarrhoea, vomiting, pallor and is frequently accompanied by convulsions. Oliguria is constantly present but not always appreciated. Hypertension may be severe. The blood shows a severe anaemia, thrombocytopenia and reticulocytosis. Some of the red cells are characteristically misshapen—acanthocytes—burr cells—triangular cells and others with a "broken egg-shell" shape are common. The blood urea is greatly elevated. The urine shows protein, red cells and granular casts. Proteinuria is in the non-nephrotic range (1–2 g/d). It has been recognised that in many of these cases sequential studies of the circulating clotting factors will show evidence of a consumptive coagulopathy due to disseminated intravascular coagulation (DIC).

**Prognosis of Haemolytic Uraemic Syndrome**

In children with HUS the complete recovery rate is about 70%, but a small number die in the acute stage of the illness; some die without recovering renal function after weeks on dialysis and other children left with hypertension and chronic renal failure. In children who develop end-stage renal disease successful renal transplantation has been reported.

**Treatment**

In D+HUS, no specific therapy has been beneficial. There is no benefit from anticoagulant or thrombolytic therapy nor from IV prostacyclin, steroids or gammaglobulins. The mainstay of treatment for children with HUS is the management of ARF.

**Prevention**

The only way to prevent HUS is to prevent primary infection by developing efficient human and animal reservoir strategies, i.e. control and improvement of food safety procedures.

**ACUTE RENAL FAILURE**

Acute renal failure is defined to describe a precipitous deterioration in renal function. The hallmark of ARF is progressive rise in plasma creatinine and urea due to accumulation of nitrogenous waste products of metabolism. The metabolic derangements include metabolic acidosis and hyperkalaemia and disturbances of body fluid balance, especially volume overload and variety of effects on almost every organ of the body. Oliguria or anuria is the cardinal feature (Box 17.7).



**Box 17.7:** Definition of acute renal failure

Oliguria—urine output:  $< 300\text{m}^2/\text{day}$  or  $0.5\text{ ml/kg/hr}$   
 Anuria—urine output:  $< 1\text{ ml/kg/day}$   
 Hypokalaemia—potassium  $> 6.0\text{ mmol/L}$   
 Clinical fluid overload  
 Oedema  
 Hypertension

**Aetiology**

The causes of ARF may be divided into three sub-groups as outlined in Table 17.4.

The causes of ARF in developing countries differ from those in developed countries and there are also other regional variations. Post-dysenteric HUS used to be the most common cause of ARF in the Indian sub-continent during the 1970s to 1980s, but its incidence has now decreased. Also stings by poisonous scorpions, wasps and bees may occasionally lead to ARF.

**Clinical Evaluation of a Child with Acute Renal Failure**

In evaluating a child with ARF the clinical history, physical examination and laboratory tests should give some clues to the cause of ARF. It is essential to exclude both pre-renal and post-renal causes before considering the intrinsic renal causes.

Pre-renal ARF should be suspected when there is a history of diarrhoea, vomiting, fluid or blood loss. Acute gastroenteritis with dehydration and shock is the most common cause of pre-renal failure. It is typically associated with high plasma urea to creatinine ratio, increased urine osmolality ( $> 500\text{ mOsm/kg}$ ), urinary sodium concentration  $< 20\text{ mEq/L}$  and fractional excretion of sodium less than 1%. The intrinsic renal parenchymal disorder can often be diagnosed

**Table 17.4:** Causes of acute renal failure

1. Pre-renal
  - Gastroenteritis, blood loss, insensible losses, burns, sepsis, anaphylaxis, diabetic ketoacidosis
2. Intrinsic renal failure
  - a. Vascular: renal vein thrombosis, HUS, HSP, SLE
  - b. Glomerular: post-streptococcal glomerulonephritis
  - c. Acute tubular necrosis: intravascular haemolysis in G-6-PD deficiency, sepsis, snake-bite, falciparum malaria, leptospirosis
3. Post-renal
  - a. Renal calculi
  - b. Neurogenic bladder
  - c. Posterior urethral valves
  - d. Ureterocele

by microscopic urinalysis and extrarenal manifestations of multisystem disease. Also in intrinsic ARF the urinary sodium is high ( $> 40\text{ mEq/L}$ ), urinary osmolality is low ( $< 300\text{ mOsm/kg}$ ) and fractional excretion of sodium is more than 1%. Ultrasonography is the ideal imaging tool in renal failure because of its non-dependence on renal function. It allows visualisation of structural anomalies, pelvicalyceal system, assessment of renal size and calculi, thus help to ascertain as to whether ARF is post-renal.

**Key Learning Point****Acute Renal Failure**

- Falciparum malaria, leptospirosis and snake-bite are important causes of ARF in India and in some other Asian countries.

**Management of Acute Renal Failure***Fluid Therapy*

As a rule of thumb fluid therapy should equal insensible fluid losses plus output (urine, vomiting, diarrhoea, etc.). Potassium containing fluids should not be given.

*Hyponatraemia*

Hyponatraemia is the common finding in children with ARF and is most frequently secondary to water excess rather than sodium loss. If doubt exists, it is safer to restrict water intake until the cause becomes clear. Profound hyponatraemia (plasma sodium  $< 120\text{ mmol/L}$ ) may cause neurological problems. Therefore, correction of hyponatraemia to a sodium level of around  $125\text{ mmol/L}$  should be considered. Also consider dialysis.

*Hyperkalaemia*

Hyperkalaemia is the most serious problem associated with ARF and causes cardiac dysfunction which may lead to death of the patient. Hyperkalaemia arises from the inability to excrete potassium in the urine and is worse in the presence of an acidosis. Potassium intake must be minimised and correction of acidosis undertaken. If ECG changes are present, or if serum potassium rises above  $7\text{ mmol/L}$  then emergency treatment is indicated, i.e. 10% calcium gluconate  $0.5\text{--}1\text{ ml/kg}$  by slow IV infusion over 5–10 minutes to reduce the toxic effect of high potassium on the heart.

The choice of potassium lowering agent remains a matter of personal choice. Many favour the use of nebulised salbutamol as it acts by moving potassium from the extracellular into the intracellular space. Also calcium resonium  $1\text{ g/kg}$  can be given orally or rectally to expedite the elimination of potassium from the body. However, the

onset of action is relatively slow and has a very limited role in the management of hyperkalaemia associated with ARF. Also consider dialysis.

### *Hypocalcaemia*

Hypocalcaemia is quite common in ARF but it rarely causes symptoms. If symptomatic then calcium can be given by slow intravenous infusion of 10% calcium gluconate 0.5 ml/kg/hr. The infusion rate being titrated according to the blood calcium level. If resistant check Mg.

### *Hyperphosphataemia*

Phosphate restriction and phosphate binders, e.g. calcium carbonate should help to deal with this problem.

### **Metabolic Acidosis**

Metabolic acidosis is a uniform and early accompaniment in this condition because of the important role of the kidneys in regulating and maintaining normal body homeostasis. When acidosis is present it should be treated with sodium bicarbonate. Intravenous 8.4% sodium bicarbonate 1–2 ml/kg equivalent to 1–2 mmol/kg should be administered where blood pH values are less than 7.25. Adequacy of pH correction should be monitored by regular measurement of blood gases. Rapid correction of acidosis may cause hypocalcaemia and tetany or seizures. Therefore rapid correction should be avoided.

### **Anaemia in Acute Renal Failure**

Mild to moderate anaemia is often present in ARF. Anaemia, when present to a significant degree, may potentiate the complications, especially cardiac failure and may be beneficial to correct by small transfusions of recently collected packed red cells.

### **Hypertension**

Severe symptomatic hypertension can occur in association with salt and water overload. Treatment of hypertension mainly consists of restriction of fluid and sodium intake and anti-hypertensive therapy. It is vital that it is adequately controlled.

### **Infection in Acute Renal Failure**

Infection is a most serious complication and every effort must be made to prevent it and to treat it if it develops.

### **Nutrition in Acute Renal Failure**

Acute renal failure is a hypercatabolic state and requires aggressive nutritional support. The aim of dietary treatment is:

- Control of dietary potassium
- Control of dietary sodium

- Control of dietary phosphate
- To tailor fluid intake to maintain fluid balance
- Vitamin and micronutrient supplements.

### **Peritoneal Dialysis or Haemodialysis**

Acute peritoneal dialysis (PD) is frequently indicated and may be life-saving. Although acute PD is the preferred choice for children, but if complications occur with PD, then haemodialysis may be necessary. In patients with multi-organ failure, haemofiltration may be required.

## **CHRONIC RENAL FAILURE**

Chronic renal failure (CRF) is defined, if the glomerular filtration rate (GFR) is less than 50 ml/minute/1.73 m<sup>2</sup> surface areas. This means that there is moderate to severe renal impairment leading to metabolic abnormalities, i.e. secondary hyperparathyroidism and growth impairment. In course of time there will be further deterioration of renal function. However, renal replacement therapy either by dialysis or renal transplantation will not be needed until the GFR falls below 10 ml/minute/1.73 m<sup>2</sup> surface areas. The initiation of renal replacement therapy marks the onset of end-stage renal disease. The causes of CRF are shown in Table 17.5.

### **Clinical Presentation**

Children with CRF present in a variety of ways. It could be related to the primary renal disease or as a result of impaired renal function. The history and clinical examination may provide useful information to the underlying cause of CRF, but in some children the cause will only be revealed by specific investigations.

### **Management**

#### *Nutrition*

Poor growth and nutritional status are common in children with CRF. Children with CRF tend to be anorexic and may have their energy intakes below the estimated average

**Table 17.5:** Causes of chronic renal failure in children

1. Congenital abnormalities
  - Aplasia, hypoplasia, obstructive uropathy, reflux nephropathy, Prune belly syndrome
2. Hereditary conditions
  - Juvenile polycystic kidney disease, cystinosis, congenital nephrotic syndrome, hereditary nephritis
3. Glomerulonephritis
  - Multisystem disease: SLE, HSP, HUS
4. Miscellaneous
  - Renal vascular disease

requirement for age. Therefore nutritional therapy should be instituted to promote improved well-being and growth.

### *Fluid and Electrolyte Balance*

Water intake is determined by the child and should therefore be offered freely to satisfy thirst. Some children may need sodium chloride intake of 4–6 mmol/kg/d for their normal physical and intellectual development while others may need their sodium intake reduced. Most children with CRF are able to maintain potassium homeostasis satisfactorily despite fluctuations in intake.

### *Acid-base Status*

Sodium bicarbonate supplement in a dose of 2 mmol/kg per day is frequently required to correct metabolic acidosis. Treatment should be monitored and dosage adjusted according to blood gas measurements of pH and bicarbonate concentration.

### *Renal Osteodystrophy or Renal Bone Disease*

Vitamin D requires hydroxylation, by the kidney and liver to its active form, therefore the hydroxylated derivative alfacalcidol or calcitriol should be prescribed for children with CRF. Alfacalcidol is generally preferred in children as there is more experience of its use and appropriate formulations are available.

### *Hypertension*

If the child's systolic or diastolic blood pressure is repeatedly in excess of the 90th centile for age, it should be treated with anti-hypertensive therapy.

### *Infection*

Urinary tract infection or any other bacterial infection should be treated appropriately.

### *Anaemia*

Chronic renal failure is associated with normochromic normocytic anaemia due to inadequate erythropoietin production. Recombinant human erythropoietin (ALFA, BETA and ZETA) is safe and effective in treating anaemia in children with CRF. The use of erythropoietins is to relieve symptoms of anaemia and to avoid the need for blood transfusion. The haemoglobin concentration should not be increased beyond that which provides adequate control of symptoms of anaemia. Aluminium toxicity, concurrent infection, or other inflammatory disease can impair the response to erythropoietin. Other factors, such as iron or folate deficiency, that contribute to the anaemia of CRF should be corrected before treatment with erythropoietin and monitored during therapy.

### *Growth*

Growth retardation is a common problem in children with CRF. If, despite optimal management, growth remains poor, i.e. the child's height velocity is below minus 2SD, a trial of synthetic human growth hormone (HGH), somatropin, produced using recombinant DNA technology should be considered.

### **Management of End-Stage Renal Failure**

Successful renal transplantation is the treatment of choice, for all children with end-stage renal failure. There is a choice between living-related kidney donation and cadaveric transplantation. Living donor transplantation avoids an unpredictable long wait for a suitable cadaveric graft and facilitates pre-emptive transplantation. Dialysis should be seen as a complement to transplantation which may be needed before or between transplants but not an alternative to transplantation. However, dialysis is the only active treatment available for infants with end-stage renal failure, since transplantation is not usually undertaken in children weighing less than 10 kg.

# Diseases of Nervous System

## INTRODUCTION

Diseases of the nervous system contribute to a significant proportion of childhood morbidity and mortality and consequently considerable parental anxiety. Precise and prompt diagnosis helps in cure, limiting disability and proper counselling. This chapter focuses on the common neurological disorders seen in childhood and comprises the following sections.

- Congenital malformations of Central Nervous System (CNS)
- Infections of the nervous system
- Acute flaccid paralysis
- Convulsions in infancy and childhood
- Childhood stroke
- Movement disorders
- Neurocutaneous syndrome
- Neurodegenerative disorders
- Neuromuscular disorders
- Autonomic nervous system
- Brain tumour in children
- Cerebral palsy
- Learning disorders

## CONGENITAL MALFORMATIONS OF CNS

The common congenital anomalies of the central nervous system are neural tube closure defects, hydrocephalus, failure of development of part of brain (aplasia or hypoplasia) and neuronal migration defects.

Neural tube closure defects include spina bifida occulta, meningocele, myelomeningocele, encephalocele and diastematomyelia. Myelomeningocele is often associated with congenital deformity of the hind brain known as the Arnold-Chiari malformation, in which the posterior fossa structures are downwardly displaced into the spinal canal resulting in hydrocephalus (see chapter 32: Fig. 32.104, Fig. 32.105)

Neuronal migration disorders include lissencephaly (smooth brain) where gyral formation does not occur, holoprosencephaly characterised by a single ventricle with a defective olfactory and optic systems (see chapter 32: Figs. 32.101A and B) and schizencephaly with unilateral or bilateral clefts within the cerebral hemispheres. Agenesis of corpus callosum may be complete or partial with varying expression from asymptomatic to severe intellectual and neurologic abnormalities.

(Section on neural tube closure defects and hydrocephalus: See Chapter 10 on Neonatal Surgery).

## MICROCEPHALY

Microcephaly is due to failure of normal brain growth and is defined as a head circumference that is more than three standard deviations below the mean for age and gender. Microcephaly can be divided into primary and secondary types.

### Primary Microcephaly

Primary microcephaly is frequently genetically determined (autosomal recessive) and may be familial. Apart from its smallness, the head has a characteristic shape with narrow forehead, slanting frontoparietal area, pointed vertex and flat occiput. The ears are often large and abnormally formed. Generalised muscular hypertonicity is a common feature. Convulsions frequently develop. These children have profound learning disorder (Fig. 18.1).

Primary microcephaly is also associated with recognisable malformation syndromes in particular chromosomal anomalies like trisomy 21, 18 and 13, and non-chromosomal syndromes such as Cornelia de Lange syndrome.

### Secondary Microcephaly

Secondary microcephaly results from severe brain damage during pregnancy or the first 2 years of postnatal life. The



**Fig. 18.1:** Familial microcephaly with mental retardation

developing brain is vulnerable to congenital infections (the acronym TORCH), drugs including alcohol, radiation, hypoxic-ischaemic encephalopathy, metabolic disorder in particular maternal diabetes and maternal hyper phenylalaninaemia, neonatal meningitis, AIDS, etc.

Investigations of children with microcephaly include possible exposure to congenital infection, drugs, radiation, etc, assessment of family and birth history and associated dysmorphic conditions. These are important to provide genetic and family counselling.

## CRANIOSYNOSTOSIS

Craniosynostosis results from premature fusion of single or multiple cranial sutures leading to deformity of skull and face. The cause of craniosynostosis is unknown but is due to abnormality of skull development. Craniosynostosis can occur isolated or as part of genetic syndromes like Crouzon's disease, Apert's syndrome and Carpenter's syndrome. Mutations of the fibroblast growth factor receptor gene family have been shown to be associated with craniosynostosis. Clinical features include abnormal asymmetric craniofacial appearance, suture ridging and premature closure of fontanelles. In sagittal synostosis lateral growth of skull is restricted, resulting in a long narrow head (scaphocephaly). In coronal synostosis expansion occurs in a superior and lateral direction (brachycephaly). This produces shallow orbits and hypertelorism. Involvement of several sutures results in skull expansion towards the vertex (oxycephaly). Frontal plagiocephaly is characterised by unilateral flattening of forehead. Neurological complications include raised intracranial pressure, hydrocephalus, proptosis, optic atrophy and deafness. The diagnosis can be confirmed by plain skull X-ray or CT scan. Surgical correction to relieve increased intracranial pressure and to improve the appearance of the head with good outcome is possible.

## INFECTIONS OF THE NERVOUS SYSTEM

Infections of the nervous system particularly meningitis form a significant proportion of serious infection in childhood.

- Acute bacterial meningitis
- Aseptic meningitis
- Tuberculous meningitis
- Viral encephalitis
- Brain abscess
- Neurocysticercosis.

The common types of meningitis are pyogenic, tuberculous and aseptic. Rare forms are mycotic (torulosis, nocardiosis, cryptococcal, histoplasmosis), syphilitic and protozoal (malaria and toxoplasmosis).

## PYOGENIC MENINGITIS

### Aetiology

Excluding the neonatal period the common bacteria infecting the meninges are pneumococcus (*Streptococcus pneumoniae*), *Haemophilus influenzae* type B and meningococcus (*Neisseria meningitidis*). *Haemophilus* infection of the meninges is most common in children 2 months to 3 years of age. The incidence has come down as a result of the conjugated *H. influenzae* vaccine. The next most common meningeal infection is due to pneumococcus; this may be secondary to upper respiratory infection or pneumonia but 'primary' meningeal infections are not uncommon. In infants and children meningococcal meningitis is usually sporadic but epidemics can occur. The disease is seen most commonly in the late winter and early spring. In infants both staphylococcal and streptococcal meningitis are occasionally seen, most often secondary to infection elsewhere, e.g. bone, skin, middle ear or lungs. A meningomyelocele, congenital or acquired CSF leak across cribriform plate, middle and inner ear and compound fractures of the skull may also act as portals of entry. In immunosuppressed children and in patients undergoing neurosurgical procedures, including ventriculoperitoneal shunts, meningitis can be caused by a variety of bacteria such as *Staphylococcus*, *Enterococcus* and *Pseudomonas aeruginosa*.

### Clinical Features

Symptomatology is common to all types of bacterial meningitis and the causal organism is most often determined by examination of the cerebrospinal fluid. There are a few characteristic signs peculiar to meningococcal infections. The important one from the diagnostic point of view is a generalised purpuric rash although this is seen only in a minority of cases. It is also characteristic of meningococcal meningitis to develop suddenly and unheralded, whereas

there is usually a preceding history of respiratory infection in cases due to Haemophilus or Penumococcus.

The onset of bacterial meningitis is usually sudden with high fever, irritability, refusal of feeds, vomiting, headache in older children and general malaise. Convulsions are common. Young infants show a tense bulging anterior fontanelle, indicative of increased intracranial pressure, and head retraction is common. The older the child the more likely is there to be nuchal rigidity, but its absence in the baby by no means excludes the diagnosis. Kernig's sign is useful in older children and may not be observed in infants. Blurring of consciousness of varying degree is the rule and increases in severity as the disease progresses. Hypertonia and decerebrate posturing may be seen in late cases. Focal neurological abnormalities such as paralytic squints, facial palsy sometimes develop. Deafness due to the damage of auditory nerve may be permanent. Papilloedema is infrequently found.

In infants the disease sometimes has a more insidious onset with diarrhoea and vomiting, irritability and "bogginess" of the anterior fontanelle. The diagnosis is easily missed unless a high index of suspicion is maintained.

## Diagnosis

Lumbar puncture is indicated whenever the possibility of meningitis has crossed the physician's mind and normally treatment should not be started before CSF has been obtained. However, it is reasonable to give intramuscular benzylpenicillin 2,50,000 units before transfer to hospital or lumbar puncture in a child suspected to have meningococcal meningitis by virtue of the characteristic purpuric or petechial rash seen in meningococcal infection. In pyogenic meningitis the cerebrospinal fluid will be turbid or frankly purulent. The white cell count may be in thousands/mm<sup>3</sup>, the majority being polymorphs. The protein content of the fluid is raised (above 0.4g/l; 40 mg/100 ml) and the glucose is greatly reduced (below 2.5 mmol/L; 45 mg/100 ml). Gram stain films of the centrifuged deposit may reveal gram-positive diplococci, often very numerous, in pneumococcal infection, gram-negative pleomorphic coccobacilli in haemophilus infection and gram-negative intra and extracellular diplococci in meningococcal infection. Rapid identification of bacterial antigen in CSF can be obtained by use of latex agglutination test. The final cause is determined by CSF culture but this may be sterile if prior antibiotic had been administered.

## Complication and Sequelae

In the acute stage, raised intracranial pressure due to cerebral oedema, subdural effusion or hydrocephalus may develop. Electrolyte imbalances particularly hyponatraemia may occur as also anaemia. Recurrent convulsions including status

epilepticus can further damage the brain. Permanent brain damage with motor and learning deficits is more common in infants, in part due to the greater difficulty and delay in diagnosis. Symptomatic epilepsy is less common. Nerve deafness can develop early in the illness and unpredictably.

## Treatment

Bacterial meningitis ought rarely to be fatal today. Management of bacterial meningitis encompasses many aspects of treatment including antibiotics, correction of fluid and electrolyte imbalances, anticonvulsant medication, anti-cerebral oedema measures and dexamethasone therapy.

The major factor in selecting antibiotic therapy for children with bacterial meningitis is the continually changing pattern of antibiotic resistance. Therefore knowledge of local susceptibility patterns is essential. Antibiotic therapy should eventually be aimed against the specific organism causing the meningitis but initial therapy is directed against all usual bacterial pathogens for the age group of the patient. The recommended antibiotics schedule for initial treatment of bacterial meningitis in different age groups is as shown in Table 18.1.

Currently a minimum of 10 days of antibiotic treatment or for 5 afebrile days whichever is longer is recommended. It has been demonstrated that intravenous dexamethasone used as an adjunctive therapeutic agent in dosage of 0.6 mg/kg per day in 4 doses for 2 days is responsible for a significantly lower incidence of neurological sequelae including hearing impairment.

Anti-cerebral oedema measures include restriction of fluid intake to two-thirds of the normal requirement, use of isotonic intravenous solution and at times intravenous mannitol. Convulsions are best controlled with intravenous

**Table 18.1:** Antibiotic therapy in children with bacterial meningitis

Age Group	Drug (IV)	Dose Per Day
Infants 1–3 months	Ampicillin and	200 mg/kg/day in 4 doses
	Cefotaxime	200 mg/kg/day in 4 doses
Older infants and children	1. Cefotaxime or	200 mg/kg/day in 4 doses
	2. Ceftriaxone	100 mg/kg/day in single dose
	3. Ampicillin and	200 mg/kg/day in 4 doses
	4. Chloramphenicol	75–100 mg/kg/day in 4 doses
	5. Benzylpenicillin	400,000 units/kg/day in 4–6 doses

If *S. pneumoniae* is resistant to beta lactam drugs then vancomycin is given at a dose of 60 mg/kg per 24 hours in four divided doses.

midazolam, lorazepam or diazepam. Recurrence of seizures is prevented by IV phenytoin.

When treatment is adequate a prompt improvement can usually be expected with a subsidence of fever within 48–96 hours. If fever persists with continuing irritability, bulging of the fontanelle, focal seizures and at times focal deficits, the presence of a subdural effusion should be suspected. This is most commonly encountered in infants with meningitis due to *Haemophilus*. Cranial ultrasound examination will be helpful to confirm the diagnosis. Subdural taps should be done through the coronal sutures on both sides. The subdural fluid is xanthochromic and protein rich. Repeated subdural taps may be required before the accumulation stops. Routine lumbar puncture at the completion of antibiotic therapy is not advised. Anaemia may have to be corrected by blood transfusion. The child with meningitis requires a high standard of professional nursing.

### THE WATER HOUSE-FRIDERICHSEN SYNDROME

This is due to acute bilateral adrenal haemorrhage seen most commonly in fulminating cases of meningococcal septicaemia. Death occurs usually before the meningitis has had time to develop, and may, in fact, take place after an illness of only a few hours duration. The characteristic clinical picture is seen in an infant who suddenly becomes ill with irritability, vomiting and diarrhoea and tachypnoea or Cheyne-Stokes breathing. The heart rate is very rapid. The infant becomes rapidly drowsy/unconscious. Peripheral cyanosis is associated frequently with a patchy purple mottling of the skin, which resembles post-mortem lividity. The child may die at this stage, about 6–8 hours from the onset of the illness. In less fulminating cases a diffuse purpuric and ecchymotic eruption appears which is the very characteristic of meningococcal septicaemia. The blood pressure may be so low as to be unrecordable. In the toddler the course of the illness tends on the whole to be less rapid than in the infant. The meningococcus is not always successfully isolated in blood cultures but can sometimes be cultured from the fluid contents of purpuric blebs on the skin. Disseminated intravascular coagulation may also develop in fulminating cases of meningococcal septicaemia and should always be sought by appropriate laboratory tests; blood count with platelet count, blood film for fragmentation of red cells, clotting screen including fibrinogen levels, FDPs or D dimers.

### Treatment

In cases where the adrenal cortex has been destroyed by haemorrhage, recovery is impossible. In some cases of fulminating meningococcal septicaemia, however, there is an intense congestion of the adrenal glands without much

haemorrhage. It is in these cases, which are clinically indistinguishable from the fully developed Waterhouse-Friderichsen syndrome, that energetic treatment can save life and lead to complete recovery. A continuous intravenous infusion of 5% dextrose with normal saline should be commenced. Penicillin should be given by direct injection in the dosage mentioned above. Hydrocortisone hemisuccinate 100 mg should be injected intravenously via the infusion at the start of treatment, to be followed by 50 mg 6-hourly for 24–48 hours; thereafter-decreasing doses of prednisolone are given orally for another few days.

### Prevention of Bacterial Meningitis

Routine immunisation of infants with conjugated *Haemophilus influenzae* type B vaccine is recommended. For close contacts of children with *Haemophilus influenzae* and meningococcal meningitis, chemoprophylaxis with rifampicin at a dosage of 20 mg/kg per day for 2–4 days is advised.

### ASEPTIC MENINGITIS

#### Definition

Aseptic meningitis refers to mostly viral meningitis as well as other forms of meningitis where gram stain and routine bacterial culture reveal no organisms.

Sporadic cases occur throughout the year, and from time to time sizeable epidemics occur. Hospital based studies looking at the different aetiologies of childhood meningitis have found that aseptic meningitis is 2–3 times more common than bacterial meningitis; also pyogenic meningitis is more common in younger children whereas aseptic meningitis is seen across all age groups.

#### Aetiology

Many viruses can cause aseptic meningitis. These include enteroviruses (particularly Coxsackie and ECHO viruses), viruses of mumps, measles, Herpes simplex and Herpes zoster, the mouse virus of lymphocytic choriomeningitis and Epstein-Barr virus. Mumps virus can cause aseptic meningitis without any of the other manifestations of this disease. Coxsackie virus can cause meningitis and paralysis, which is indistinguishable clinically from classical poliomyelitis. Non-viral agents, which can cause aseptic meningitis, include *Leptospira* (icterohaemorrhagiae and canicola), *Treponema pallidum*, *Toxoplasma gondii* and *Trichinella spiralis*.

#### Clinical Features

The onset is usually sudden with fever, headache, neck pain, vomiting, malaise, diarrhoea or constipation. In some cases, especially of poliomyelitis there is a preceding illness about

1 week earlier with fever, headache, malaise, sore throat and abdominal pain. The temperature chart in such cases shows two “humps”, sometimes called “the dromedary chart”. The child may be drowsy, apathetic and irritable when disturbed, but marked blurring of consciousness is uncommon. Slight nuchal rigidity is usually found. In the infant the anterior fontanelle may be tense and full. Compared to bacterial meningitis, meningeal signs and focal seizures are less common in aseptic meningitis. Exanthema may precede or accompany the CNS signs.

### Diagnosis

The cerebrospinal fluid is clear or only slightly hazy. The cell count varies from 50–1000/mm<sup>3</sup> (may be higher in lymphocytic choriomeningitis) with lymphocytic predominance. The glucose content is normal but the protein content is moderately elevated (50–200 mg/100 ml). The culture remains sterile. The main differential diagnosis is partially treated pyogenic meningitis. CSF bacterial antigen detection test can be helpful. The causative virus can be identified in the stools. The serum (at least two specimens taken within a 10-day interval) may be tested for neutralising antibody or complement fixation in rising titre. Identification of the viral DNA after PCR amplification in CSF is now possible but may give false positive result.

### Treatment

In the great majority spontaneous recovery occurs. Symptomatic measures to relieve fever, headache or muscle pain are required. Specific treatment is available only for Herpes simplex infection (Acyclovir).

## ACUTE ENCEPHALITIS AND ENCEPHALOPATHY

The term encephalitis denotes infection affecting the brain substance. The term encephalopathy is used to describe functional disturbances of the brain without actual infection of the brain.

### Aetiology

All of the viruses mentioned in connection with the aseptic meningitis can cause acute encephalitis. Others include arboviruses like Japanese encephalitis virus, influenza virus, cytomegalic inclusion disease in infancy, and the viruses of rabies, HIV, encephalitis lethargica and the zymotic diseases such as measles and varicella. Special mention must be made of Herpes simplex virus (HSV). In the new born infant HSV type 2 can cause a disseminated infection involving many tissues with a grave prognosis. In the older children Herpes simplex virus type 1 infection of the brain causes acute necrotising encephalitis affecting particularly the temporal lobe.

In the Indian subcontinent, Japanese encephalitis transmitted by *Culex* mosquito is common, often in epidemic form, during the monsoon season.

### Clinical Features

These are extremely protean. The onset of the illness is usually acute and a prodromal stage with general malaise, fever, headache and vomiting often precedes signs of CNS involvement. The acute encephalitic stage may show varying disturbances of cerebration from the gradual onset of stupor or coma to the sudden onset of violent convulsions. Headache, fever, irritability, mental confusion, abnormal behaviour, and seizures may be marked. Focal neurological signs of many kinds are encountered such as cranial nerve palsies, speech disturbances, spastic palsies, cerebellar disturbances and abnormalities in the various reflexes. In cases of acute necrotising encephalitis caused by herpes virus type 1, in addition to the clinical manifestation described above, some cases have had neurological signs suggestive of an expanding lesion in the brain, particularly in the temporal lobe.

The outcome is always doubtful in every case of encephalitis and especially grave in acute necrotising encephalitis. Death is not uncommon. The case fatality rate in Japanese encephalitis has varied between 25% and 45%. Although complete recovery is possible, many are left with permanent disability such as mental deterioration, hemiplegia or paraplegia, and epilepsy. In some children an apparently good recovery is followed later by learning difficulties or behaviour problems.

### Diagnosis

The diagnosis is usually made on clinical grounds supported by CSF analysis, which shows a mild pleocytosis and increase in protein. EEG typically shows diffuse slow-wave abnormalities. Focal findings and Periodic lateralised epileptiform discharges (PLEDS) on EEG or CT or MRI, especially involving the temporal lobes, suggest HSV encephalitis. Virological studies are often successful in determining the causal agent.

### Treatment

With the exception of herpes encephalitis, treatment of other viral encephalitis is essentially supportive and consists of control of hyperpyrexia and convulsion, reduction of raised intracranial pressure, and expert nursing, the latter being of utmost importance. Convulsions must be controlled with intravenous midazolam or diazepam or phenytoin. A clear airway must be ensured by proper positioning and frequent pharyngeal suction. Management of status epilepticus may need intravenous midazolam infusion along with tracheal intubation and mechanical ventilation. Frequently, tube



feeding or intravenous fluids are indicated. Patients should be monitored for signs of raised intracranial pressure and managed appropriately. Fluid and electrolyte balance must be maintained. Distension of the bladder must be anticipated and controlled by an in-dwelling catheter.

For HSV encephalitis, intravenous acyclovir is given in a dose of 10 mg/kg every 8 hours for 10 days. During the convalescent stage physiotherapy, occupational therapy and rehabilitation treatment are important.

In addition to the viral encephalitis, which may occur, early in the infectious fever such as measles, rubella and chickenpox, an encephalitic illness of later onset may occur during the period of recovery. This is characterised histologically by extensive demyelination in the brain substance and the pathogenesis is probably a vasculopathy mediated by immune complexes with lesions occurring in central nervous tissue myelin. This is known as post-infectious or acute disseminated encephalomyelitis (ADEM).

### SCLEROSING PANENCEPHALITIS

There is yet another type of encephalitis produced by measles virus which develops some years after apparent recovery from the measles illness itself. The disease is called subacute sclerosing panencephalitis (SSPE). Histologically the disease is characterised by intranuclear inclusions, and under the electron microscopy these are seen to contain tubular structures typical of the nucleocapsids of paramyxoviruses. Measles antigen has also been demonstrated in the brain by fluorescent antibody techniques and measles virus itself has been isolated from brain tissue of patients with SSPE. The initial attack of measles usually antedates the onset of encephalitic manifestation by several years. Infection with measles during infancy seems to increase the risk of SSPE. The disease has also been reported to follow immunisation with live measles virus vaccine but the risk is very much less than with wild measles virus infection. Viral mutation, abnormal immune response to measles virus or subtle predisposing immune deficiency has been proposed to explain the persistent measles virus infection of the CNS.

#### Clinical Features

The onset is insidious over a period of months and occurs mostly from 5–15 years of age with preponderance among boys. There is insidious deterioration of behaviour and school performance progressing to a state of dementia. Major epileptic seizures may occur. A somewhat characteristic form of myoclonic jerk is commonly seen in which the child makes repetitive stereotyped movements with rhythmic regularity (2–6 per minute); each begins with shock-like abruptness typical of the myoclonic jerk, but then the elevated limb remains “frozen” for a second or two before, and unlike the

usual myoclonic jerk, it gradually melts away. Pyramidal and extra-pyramidal signs are common. The final stage of decerebrate rigidity, severe dementia and coma is reached about 1 year or more from onset and death occurs usually 1–3 years after diagnosis. Rarely, clinical arrest has been reported.

The CSF cell count is usually normal. Although the total protein content of the CSF may be normal or only slightly elevated, the gamma globulin fraction is greatly elevated resulting in a paretic type of colloidal gold curve. On CSF electrophoresis, oligoclonal bands of Ig are often observed. High levels of antibody in CSF in dilutions of 1 equal 8 or more to measles are found. The EEG at the start of the illness may show only some excess slow-wave activity. Later in the illness bilateral periodic complexes typical of the disease appear. The EEG then shows high-amplitude slow-wave complexes, frequently having the same rhythmicity as the myoclonic jerk, sometimes with a frequency of 6–10 seconds (burst-suppression episodes). Finally the EEG becomes increasingly disorganised with random dysrhythmic slowing and lower amplitudes.

Treatment is mainly supportive. Administration of inosiplex (100 mg/kg per 24 hr) may prolong survival and produce some clinical improvement. Measles vaccination is the most effective measure to prevent SSPE.

### ACUTE ENCEPHALOPATHY

The term acute encephalopathy refers to acute cerebral disorder associated with convulsions, stupor, coma and abnormalities of muscle tone. There is no actual infection of the brain substance. In some cases there has been a recent preceding virus infection. Rarely, it may be related to the administration of a vaccine. Occasionally, the child may have an underlying inherited metabolic defect such as maple syrup urine disease, organic aciduria or fatty acid, peroxisomal or mitochondrial metabolic defect. The cerebrospinal fluid is usually normal and apart from oedema the findings in the brain are remarkably inconspicuous. One distinct clinicopathological entity is Reye syndrome. Here an acute encephalopathy with fatty degeneration of the viscera in a young child is associated with hypoglycaemia, hyperammonaemia, greatly elevated aminotransferases, metabolic acidosis and respiratory alkalosis with prolongation of the prothrombin time. The CSF generally is clear and acellular with a normal protein concentration and reduced glucose level. At autopsy the liver is enlarged and shows gross fatty change, being greasy and pale yellow in colour. The brain shows only oedema. However, electron microscopy reveals distinctive mitochondrial changes in both hepatocytes and neurons. The syndrome follows viral infection with influenza B and varicella. The evidence to

support a possible association between Reye syndrome and aspirin ingestion is not absolute but sufficient to discourage the use of aspirin for children. Treatment remains non-specific in this syndrome because the precise aetiology and pathogenesis remain obscure. None the less the correction of hypoglycaemia, electrolyte imbalance, bleeding diathesis, metabolic disturbances and control of intracranial pressure may suffice in the early cases. The mortality and morbidity are high in late cases.

## TUBERCULOSIS OF THE CENTRAL NERVOUS SYSTEM

Tuberculosis of the central nervous system is the most serious complication of primary tuberculosis in children. The clinical presentation commonly takes the form of meningitis. Less commonly, single or multiple tuberculomata enlarge and present as intracranial tumours. Tuberculous disease may also be confined to the spinal cord.

### Tuberculous Meningitis

This develops following the rupture of a caseous subcortical focus (Rich focus) into the subarachnoid space and is commonest in children between 6 months to 5 years of age. Sometimes it is preceded by a head injury or an intercurrent infection such as measles, mumps or pertussis. Human immunodeficiency viral (HIV) infection predisposes children to tuberculous infection including TB meningitis. The onset of symptoms is insidious and progresses gradually over some weeks and may be grouped into stages, which give a guide to prognosis. In infants the disease may run a more rapid course. Initially, the symptoms are non-specific and include lethargy, irritability, anorexia, headache, vomiting, abdominal pain, constipation and low-grade fever. The child's consciousness is unimpaired and neurological signs are absent. Unless there is a high index of suspicion and a positive contact history, the diagnosis is easily missed at this stage. About 2 weeks later the intermediate stage develops with obvious blurring of consciousness, nuchal rigidity, positive Kernig's sign and focal neurological signs such as cranial nerve paralysis (ophthalmoplegia and facial paralysis) and hemiplegia. Seizures may develop. Raised intracranial pressure may manifest as full "boggy" fontanelle in an infant and "cracked pot resonance" in the older child. Fundoscopy may reveal choroidal tubercles indicating an associated miliary tuberculosis, papilloedema or the development of optic atrophy.

The third and final stage is characterised by coma, decerebrate rigidity, paralytic squints, unequal or dilated pupils, other neurological signs, and marked wasting. Convulsions are common. Vasomotor instability and terminal hyperpyrexia may occur. The combination of cerebral

vasculitis, infarction, cerebral oedema and communicating hydrocephalus due to obstruction to CSF flow at the level of basal cisterns, leads to severe brain damage with little hope of recovery and the incidence of permanent brain damage such as hydrocephalus, blindness, deafness, mental retardation and learning impairment are high.

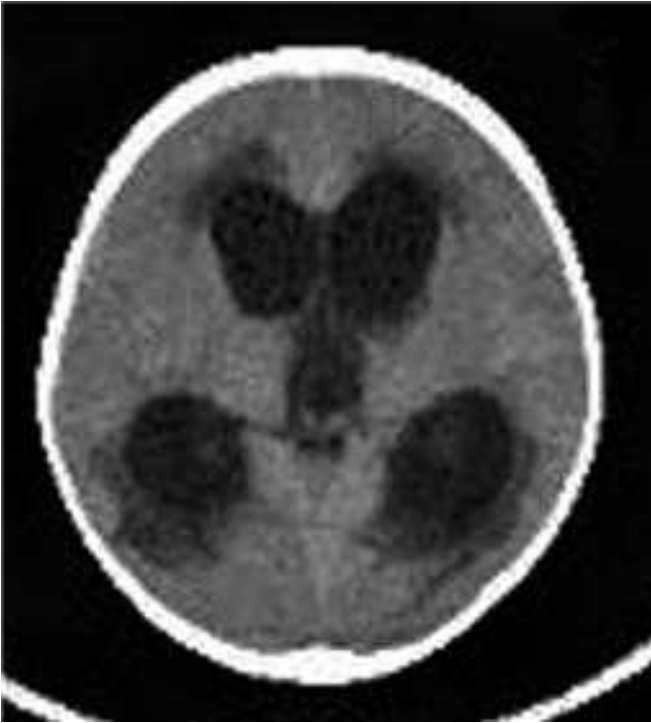
### Diagnosis

The diagnosis is based on a positive contact history, clinical examination, positive Mantoux test, chest radiograph and CSF analysis. Mantoux test may be negative in advanced stages and in severe malnutrition. The CSF is often under pressure and may be clear or opalescent depending on the cell count. The CSF cell count varies between  $50/\text{mm}^3$  and  $500/\text{mm}^3$  with lymphocyte predominance. The protein content is raised above 40 mg/100 ml and may be even in gms/100 ml. The glucose content is low between 20 mg/dl and 40 mg/dl. The final proof is the detection of tubercle bacilli by acid-fast stain of the CSF sediment or cobweb clot and mycobacterial culture. Identification of specific DNA sequences of *Mycobacterium tuberculosis* after polymerase chain reaction (PCR) amplification in the CSF is possible but there are risks of contamination and false positive results. Cultures of other fluids, such as gastric aspirate or urine may help confirm the diagnosis. CT or MRI scan of the brain will show basal exudate, communicating hydrocephalus, cerebral oedema and focal ischaemia (Fig. 18.2).

Tuberculous meningitis is most likely to be mistaken for partially treated pyogenic meningitis or aseptic meningitis due to viruses. In these cases the onset is usually much more acute than in tuberculosis cases, with brisk fever and obvious early rigidity of the neck and spine. The cerebrospinal fluid may show a lymphocytic pleocytosis but in viral aseptic meningitis there is no fall in sugar content, the protein content is less markedly raised and a spider-web clot rarely, if ever, forms. There will be no other indications of tuberculosis in these cases. Detection of bacterial antigen in CSF by latex agglutination test and a positive bacterial CSF and blood culture will help to differentiate pyogenic meningitis. In older children tuberculous meningitis can simulate brain tumour, but the cerebrospinal fluid and CT or MRI scan of the brain will reveal the true state of affairs. Tuberculomas in children are often infratentorial in location, and may be single or multiple.

### Treatment

In tuberculous meningitis the results depend upon the stage at which treatment is started. The prognosis for young infants is generally worse than for older children. The optimal chemotherapy is the use of a combination of antituberculous drugs with good penetration into the CSF and low toxicity,



**Fig. 18.2:** Tuberculous meningitis. CT brain showing moderate communicating hydrocephalus with periventricular hypodensities—suggestive of CSF seepage. Enhancing basal exudates noted

for sufficient duration. A suggested regimen is isoniazid (5–10 mg/kg), rifampicin (10 mg/kg), pyrazinamide (25–30 mg/kg) and ethambutol (20 mg/kg) given in single daily dose on an empty stomach for the first 2 months followed by isoniazid, rifampicin and ethambutol for another 10 months. Rifampicin may cause gastric upset, red coloured urine and a rise in liver transaminases but these side effects are rarely severe. Isoniazid may cause convulsions in young infants and peripheral neuropathy in older patients. Although children taking isoniazid may have transient elevation of serum transaminase, clinically significant hepatotoxicity is rare. Corticosteroids are normally administered during the first few weeks of treatment to reduce cerebral oedema and prevent formation of adhesions and hydrocephalus. Initially dexamethasone 0.6 mg/kg per day in 3–4 divided doses is given, followed by prednisolone (1–2 mg/kg per day) for 2–4 weeks and gradually tapered off.

Good nursing care and adequate nutrition are important. Anti-convulsant therapy may be required to control seizures. Close family contacts should be screened for tuberculosis.

### Complication

During treatment neurological complications may arise due to obstructive hydrocephalus, thrombosis of cerebral vessels and the involvement of cranial nerves in basal exudate.

Serial cranial CT scans should be performed on all patients to detect the presence or development of hydrocephalus. Ventriculoperitoneal shunt surgery may be necessary.

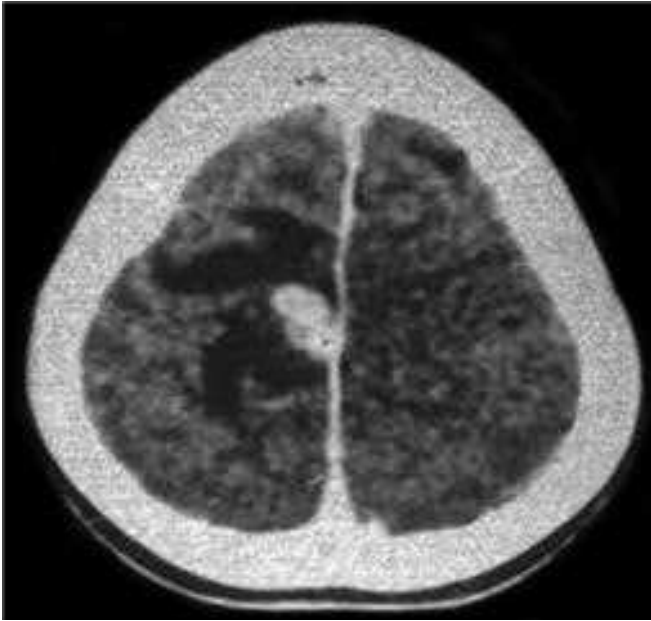
### BRAIN ABSCESS

Pus accumulation in brain parenchyma may occur as a complication of meningitis, due to haematogenous spread of septic emboli from infective endocarditis and congenital cyanotic heart disease (especially tetralogy of Fallot), extension of infection from chronic otitis media and mastoiditis, and penetrating head injuries. The site of abscess depends on the source, e.g. chronic otitis media and mastoiditis leading to abscess formation in temporal lobe and cerebellum. The usual organisms are streptococcus (especially *Streptococcus viridans*), anaerobic organisms, *Staphylococcus aureus* and gram-negative organisms particularly *Citrobacter*. In immune compromised children fungal organisms may be responsible.

The symptoms and signs usually develop over 2–3 weeks and initially are non-specific with low-grade fever and headache. Later signs of raised intracranial pressure, seizures and focal neurological signs develop. Cerebellar signs may be obvious. The diagnosis is confirmed by contrast CT scan which shows a central area of low density with marked ‘ring’ enhancement and surrounding area of low density due to oedema. There may be shift of the midline. Lumbar puncture should not be performed in a child suspected to have brain abscess (See Chapter 32: Fig. 32.126). The treatment consists of appropriate antibiotics and aspiration of the pus. The usual antibiotic combination is a third-generation cephalosporin, metronidazole and benzyl penicillin. Associated infection such as mastoiditis should be treated.

### NEUROCYSTICERCOSIS

Neurocysticercosis is the most common parasitic infestation of the central nervous system, and is caused by pork tapeworm *Taenia solium* in its larval stage. Human cysticercosis usually results when humans ingest vegetables contaminated with the eggs of *Taenia solium*. The cysticerci develop almost anywhere but particularly in the skin, muscle, brain and eye. Neurocysticercosis has been reported even in young children. It manifests commonly with seizures, but can also cause signs of increased intracranial pressure, meningitis, behavioural disorders, paresis and hydrocephalus. The seizures are mostly focal in nature. A phenomenon peculiar to patients in the Indian subcontinent is the solitary cysticercus granuloma which shows up as a single, small, enhancing lesion on the contrast enhanced computerised tomography (CT) scan, with significant surrounding oedema located superficially near the cortex (Fig. 18.3). The usual presentation is a simple partial seizure often with post-ictal deficit in the form of monoparesis or hemiparesis. The deficit is usually temporary



**Fig. 18.3:** Neurocysticercosis. CT scans showing four ring enhancing lesions close to the midline in the left fronto-parietal region with surrounding oedema

and the CT lesion resolves spontaneously over a period of time. Serologic tests like enzyme-linked immunosorbent assay (ELISA) and enzyme-linked immuno electrotransfer blots (EITB) can be useful to confirm the diagnosis. Since active solitary parenchymal lesions resolve spontaneously, only anti-epileptic drug is advised usually for a 6-month period. However persistent, enlarging or multiple lesions need anticysticercal drugs. Albendazole is preferred at a dosage of 15 mg/kg per day in 2 divided doses for 28 days. A worsening of symptoms may follow the use of Albendazole due to host inflammatory response to dying parasite. A short course of steroids for about 5 days can ameliorate these effects.

## ACUTE FLACCID PARALYSIS

Acute flaccid paralysis is defined as onset of weakness and floppiness within 2 weeks in any part of the body in a child less than 15 years of age. The common causes of acute flaccid paralysis are acute paralytic poliomyelitis, Guillian-Barre' syndrome, traumatic neuritis and transverse myelitis. Other causes include non-polio enterovirus infections, encephalitis, meningitis, toxins, etc.

### Acute Poliomyelitis

This is caused by poliovirus, which comprises three serotypes: Types 1, 2 and 3 of which type 1 is the commonest cause for poliomyelitis. Transmission is primarily person-to-



**Fig. 18.4:** Acute flaccid paralysis due to poliomyelitis

person via the faecal-oral route. Unimmunised children, 6 months to 3 years of age, are most susceptible. In 90–95% of infected individuals, poliovirus infection is inapparent. In the remaining infected individuals, one of the three syndromes may occur.

1. Abortive polio is characterised by a minor illness with low-grade fever, sore throat, vomiting, abdominal pain and malaise. Recovery is rapid and there is no paralysis.
2. Non-paralytic aseptic meningitis is characterised by headache, neck, back and leg stiffness preceded about a week earlier by a prodrome similar to abortive polio. The child may be drowsy and irritable; spinal stiffness is manifested by the tripod sign. There is no paralysis.
3. Paralytic poliomyelitis occurs in about 1% of infected individuals. Symptoms often occur in two phases with a symptom-free interval. The minor consisting of the symptoms of abortive poliomyelitis and the major illness characterised by high grade fever, muscle pain and stiffness followed by rapid onset of flaccid paralysis that is usually complete within 72 hours (Fig. 18.4).

There are three types of paralytic poliomyelitis:

1. Spinal poliomyelitis: This accounts for newly 80% of the paralytic poliomyelitis. It results from a lower motor neuron lesion of the anterior horn cells of the spinal cord and affects the muscles of the legs, arms and/or trunk. Paralysis is asymmetrical and the sensory system is intact. The affected muscles are tender; floppy and tendon reflexes are lost or diminished.

2. Bulbar poliomyelitis results from involvement of lower cranial nerves and can cause facial paralysis, difficulty in swallowing, eating or speech and respiratory insufficiency.
3. Bulbosplinal poliomyelitis involves both bulbar cranial nerves and spinal cord.
4. Life is endangered in case of bulbar involvement with inability to swallow and obstruction of the airway and when the muscles of respiration are involved.

As the acute phase of paralytic poliomyelitis subsides over 4 weeks, recovery begins in paralysed muscles. The extent of recovery is variable depending upon the extent of damage caused to the neurones by the virus. Maximum recovery takes place in the first six months after the illness but slow recovery can continue up to 2 years. After 2 years, no more recovery is expected and the child is said to have post-polio residual paralysis. Affected muscles atrophy and deformities such as pes cavus, talipes or scoliosis and ultimate shortening of the affected limb may develop.

Poliovirus can be isolated from the stool specimen. Paired serum may be tested for neutralising antibody in rising titre. The cerebrospinal fluid is clear or only slightly hazy. The cell count varies from 50 to a few hundreds per cubic millimeter with lymphocytic predominance. The sugar level is normal but the protein content is elevated leading at times to 'cyto-albumino dissociation'.

Treatment is mainly supportive with complete bed rest, proper positioning of the affected limb and passive range of movement at the joints. Massage and intramuscular injection should be avoided during the acute phase of illness. Children with bulbar involvement and respiratory paralysis would need hospitalisation and close monitoring. Moist heat and analgesics can be given to relieve pain and fever. Physiotherapy plays an important role during recovery. Orthosis may be required for ambulation and children with fixed deformities and contractures may require orthopaedic surgery.

Poliomyelitis can be prevented by active immunisation with trivalent oral polio vaccine. Besides in endemic countries, national immunisation days (or Pulse Polio Immunisation) are conducted in which 2 doses of oral polio vaccine are administered at an interval of 6 weeks to all children aged 0–5 years regardless of previous vaccination history. Ongoing surveillance of all acute flaccid paralysis (AFP) cases is an important aspect of polio eradication. This involves AFP case reporting, investigation, stool collection and laboratory confirmation. After the AFP case investigation and stool specimen collection, outbreak response immunisation is organised in the community and children aged 0–5 years are given one dose of trivalent oral polio virus vaccine regardless of their prior immunisation status.

## ACUTE POSTINFECTIOUS POLYNEUROPATHY (GUILLAIN-BARRE' SYNDROME)

It is an acute inflammatory demyelinating polyradiculoneuropathy affecting the spinal nerve roots, peripheral nerves and cranial nerves. It involves primarily the motor but sometimes also sensory and autonomic nerves. It typically occurs after recovery from a viral infection or in rare cases, following immunisation. The commonly identified triggering agents are *Helicobacter jejuni*, cytomegalovirus, Epstein-Barr virus and *Mycoplasma pneumoniae*. It is believed to be due to a "cross-reactive" immune attack by host antibodies and T-lymphocytes on nerve components. Guillain-Barre` syndrome (GBS) is now appreciated as a heterogeneous spectrum of disorders with distinct subtypes. Some patients have mainly loss of myelin which is the most common type termed acute inflammatory demyelinating polyradiculoneuropathy (AIDP), while others have predominantly axonal damage involving both sensory and motor nerves termed acute motor-sensory axonal neuropathy (AMSAN). A pure motor axonal form is called acute motor axonal neuropathy (AMAN), which tend to be more severe. Another subtype, the Miller-Fisher syndrome, consists of acute onset of ataxia, areflexia and ophthalmoplegia. Other variants of GBS include acute pandysautonomia and polyneuritis cranialis.

### Clinical Features

After an upper respiratory febrile illness or acute gastroenteritis, the child develops increasing muscle weakness and tenderness with loss of deep tendon reflexes. The lower limbs are the first to be affected followed by involvement of the trunk, upper limbs and finally the bulbar muscles (Landry's ascending paralysis). The disease can progress over days to 4 weeks. Proximal and distal muscles are involved relatively symmetrically. Sensory changes tend to be minimal. Intercostal and diaphragmatic paralysis may endanger life. Bilateral facial paralysis is common. Autonomic nervous system involvement may manifest with tachycardia and hypertension. In the typical Guillain-Barre' syndrome the cerebrospinal fluid shows a high protein content with little or no pleocytosis, but these changes are inconstant and may be late in appearing. Motor nerve conduction velocities are greatly reduced. Electromyogram shows evidence of acute denervation of muscle.

### Treatment

Most cases recover spontaneously over a period of weeks to months with supportive treatment with good nursing care and physiotherapy. Respiratory paralysis may necessitate tracheostomy and assisted ventilation. Rapidly progressive

paralysis is treated with intravenous immunoglobulin therapy (0.4 gm/kg per day) administered for 5 days. Plasmapheresis is the other alternative.

## CONVULSIONS IN INFANCY AND CHILDHOOD

Convulsion is a common acute and potentially life-threatening event encountered in infants and children. About 5% of the children would have had one or more convulsion by the time they reach maturity. A convulsion (epileptic seizure) is defined as a transient occurrence of signs and/or symptoms due to abnormal excessive or synchronous neuronal activity in the brain. The clinical manifestation consists of sudden and transitory abnormal phenomena which may include alterations of consciousness, motor, sensory, autonomic, or psychic events perceived by the patient or an observer.

### Aetiology

Seizures may be either provoked or unprovoked. The common provoking factors include high fever, perinatal damage, hypoglycaemia, hypocalcaemia, hyponatraemia, hypernatraemia, intracranial infections, head injury, tumours, inherited metabolic disorders and developmental anomalies of the brain. Inborn errors of metabolism causing seizures include non ketotic hyperglycinaemia, mitochondrial glutamate transporter defect, Menkes disease to mention a few. Some of the treatable metabolic disorders with seizures include pyridoxine responsive seizures, folinic acid responsive seizures and seizures due to biotinidase deficiency. Hyponatraemia can result from water intoxication, retention of water and acute infections of the brain. Hypernatraemia occurs due to severe hypertonic dehydration, inappropriate use of oral rehydration solution. Intoxications with pesticides, organophosphorus compounds and drug overdose due to phenothiazines, salicylates can cause seizures and so also lead poisoning. Finally, hypertensive encephalopathy as a cause of convulsions in childhood is not excessively rare.

Unprovoked seizures are the result of a brain disorder producing recurrent spontaneous paroxysmal discharges of cerebral neurones. The term epilepsy is used when two or more unprovoked seizures occur at an interval of greater than 24 hours apart. However the close inter-relationship between the provoked and unprovoked groups, which overlap each other, must not be forgotten. It should be stressed further that in a high proportion of children with epilepsy and in a similar proportion with provoked seizures a family history of epileptic seizures or of infantile convulsions is obtainable.

Whereas there is a 1 in 200 risk of any child or adolescent experiencing an epileptic seizure, approximately one-third of the children and adolescents with learning disabilities,

**Table 18.2:** Classification of seizures (ILAE 2010)

#### *Generalised seizures*

- Tonic-clonic
- Absence
- Myoclonic
- Clonic
- Tonic
- Atonic

#### *Focal seizures*

#### Unknown

- Epileptic spasms

cerebral palsy and autistic disorders will develop epileptic seizures.

### Classification

Epileptic seizures are generally classified based on the clinical features of the attack and the accompanying Electroencephalograph (EEG). The recent classification of seizures proposed by the International League Against Epilepsy (ILAE) 2010 is shown in Table 18.2. The EEG changes are frequently characteristic in the different clinical types but this correlation is by no means firm and a good deal of overlap and mixing of types occur. A normal EEG does not preclude the diagnosis of epilepsy especially the interictal recording.

Once the seizure type is determined, the epilepsy is then categorised as an electroclinical syndrome, constellation, structural/metabolic epilepsy or epilepsy of unknown cause. An electroclinical syndrome is a complex of clinical features, signs, and symptoms that together define a distinctive, recognisable clinical disorder. This includes West syndrome, Dravet's syndrome, Myoclonic epilepsy in infancy, Febrile seizure plus syndrome, Lennox-Gastaut syndrome, Landau-Kleffner syndrome (LKS), Benign epilepsy with centrotemporal spikes (BECTS), earlier referred to as Rolandic epilepsy, Juvenile myoclonic epilepsy (JME) to mention a few. This syndromic diagnosis has implications for treatment, management, and prognosis. Electroclinical syndromes also have strong developmental and genetic components. Constellations are epilepsy disorders which till date do not have a genetic basis but have characteristic clinical features due to a specific lesion or cause. These include mesial temporal lobe epilepsy with hippocampal sclerosis, epilepsy with hemicconvulsion and hemiplaegia and Rasmussen syndrome. Structural/metabolic epilepsy as the term implies, refers to epilepsy due to a specific structural or metabolic lesion or condition. Epilepsies of unknown cause in the past were termed "cryptogenic" and will include epilepsies of unknown cause.

A patient is said to be in status epilepticus when seizure lasts or occurs in succession for more than 30 minutes without intervening periods of recovery. All seizures lasting more than 5 minutes have the risk of progressing to status epilepticus and hence are now termed ‘threatened’ or ‘impending’ status epilepticus. The time duration has been modified so that aggressive treatment can start after 5–10 minutes of active seizures to reduce morbidity and mortality. Refractory status epilepticus includes seizures that last beyond 30 minutes despite adequate initial doses of 2 or 3 anticonvulsant medications. It is a true medical emergency and can end fatally or with permanent sequelae of hypoxic brain damage. Secondary metabolic complications appear when convulsive status is prolonged. Lactic acidosis becomes prominent and cerebrospinal fluid pressure rises. Initial hyperglycaemia is followed by hypoglycaemia and autonomic dysfunctions appear consisting of hyperthermia, excessive sweating, dehydration, hypotension and eventually shock. Cardiovascular, respiratory and renal failure may result.

### Generalised Seizures

Generalised seizure is a seizure that has an initial semiology which indicates or is consistent with more than minimal involvement of both cerebral hemispheres. This includes tonic-clonic, absence, myoclonic, clonic, tonic and atonic seizures.

#### *Tonic-Clonic Seizure (Grand Mal)*

A generalised tonic clonic seizure (GTCS) is the commonest, dramatic clinical manifestation of a seizure. Its features include sudden loss of consciousness, possible injury from falling, tonic followed by clonic spasms, tongue biting, possible urinary or faecal incontinence, and frothing at the mouth. It is followed by post-ictal sleep, or a period of confusion or automatism. A careful examination is essential to exclude a provoking cause, which requires specific treatment. In febrile convulsion the convulsion is short, solitary and occurs at the onset of the illness. A prolonged or recurrent convulsion in a febrile child may well herald idiopathic epilepsy and the physician should be guarded in his prognosis in these circumstances. In grand mal epilepsy the EEG shows most often frequent high-voltage spikes, but there may instead, or in addition, be spike-and-wave or slow-wave patterns. Even a normal EEG is not uncommon in major epilepsy and in no sense excludes such a diagnosis when the history is typical.

#### *Absence Seizure (Petit Mal)*

The hallmark of an absence attack is a sudden onset, interruption of ongoing activities, a blank stare with possibly

a brief upward rotation of the eyes in which the EEG shows a characteristic 3 per second spike-and-wave pattern. Consciousness and activity are resumed immediately after a few seconds. There is no post-ictal confusion or drowsiness. Activation, particularly hyperventilation, often can precipitate electrical and clinical seizures. Having the patient take about 60 deep breaths per minute for 3–4 minutes often precipitates a typical attack. Absence seizures are differentiated from complex partial seizures by their increased frequency, shorter duration, absence of loss of body tone, balance or post-ictal phenomenon. The distinction is important in treatment. Childhood absence epilepsy (earlier termed pyknolepsy) has its onset between 4 years and 10 years of age and two-thirds of the patients are girls. More than 90% of them remit by 12 years of age and the rest of them develop infrequent GTCS in adult life.

#### *Myoclonic Seizure*

Myoclonic jerks are shock-like, irregular and often arrhythmic, clonic-twitching movements that are singular or repetitive. They predominantly affect the eyelids, facial and neck muscles, the upper limbs more than the lower limbs and the body. They may occur as the sole manifestation of epilepsy or in children who also have grand mal seizures. The muscular contractions may be sufficiently violent to throw the child to the ground causing injuries or they may drop things. This type of epilepsy occurs due to multiple cause particularly degenerative and metabolic disease. The EEG frequently shows atypical slow spike-and-wave or polyspike discharges, which are more or less asymmetrical.

#### *Infantile Spasms*

These attacks, often extremely numerous each day, consist of a series of sudden jerks of the whole body, head and limbs. Most often the head and trunk flex suddenly forward while the arms jump forwards (salaam seizures) or up along side the head, but the spasms may also be opisthotonic (extensor) in nature. Mixed flexor-extensor spasms are the most common type followed by flexor spasms; extensor spasms are the least common. Infantile spasms are the defining clinical manifestation of West syndrome, the onset of which is usually between the ages of 3 months and 9 months. Other causes of infantile spasms include perinatal insults as hypoxia, hypoglycaemia and intracranial haemorrhage, or to prenatal causes such as developmental malformations, toxoplasmosis and tuberous sclerosis, or to an inborn metabolic error such as phenylketonuria. The fits often become less frequent with the passage of time and may cease spontaneously. The EEG always shows gross abnormalities; the most severe and characteristic has been termed “hypsarrhythmia”. This amounts to total chaos with asynchrony, high amplitude irregular spike-

and-wave activity, no recognised discharges and no formal background activity. The triad of infantile spasms, arrest of psychomotor development and hypsarrhythmia has become known as the West syndrome. Idiopathic and cryptogenic infantile spasms have a better prognosis than symptomatic cases. Development is normal or mildly impaired in only less than 10%, and the rest show various degrees of psychomotor retardation.

### *Atonic Seizures*

In these attacks the child suddenly loses muscle tone and drops to the floor with transient unconsciousness. This type of seizure is usually seen in children with Lennox-Gastaut syndrome.

### *Focal Seizures*

Focal seizures replace the older terminology of 'partial' and 'localisation-related' epileptic seizures. A focal seizure denotes a seizure semiology which indicates or is consistent with initial activation of only part of one cerebral hemisphere. The ILAE 2010 classification does not distinguish focal seizures into simple partial (without impairment of consciousness) and complex partial (with impairment of consciousness) seizures.

Focal seizures are described as those without impairment of consciousness or awareness with observable motor or autonomic components or involving subjective sensory or psychic phenomena. This would correspond to the concept of simple partial seizure. Here the twitching or jerking starts in one area, arms or limb, and spreads in an orderly fashion until one half of the body is affected. This may be followed by a transient hemiparesis-Todd paralysis. In simple sensory seizures, the patient complains of paraesthesia or tingling in an extremity or face. Simple partial seizures often indicate structural brain disease, the focal onset localising the organic lesion. Conjugate deviation of the head and eyes to one side may indicate a lesion in the opposite frontal lobe. Tingling in a foot incriminates the opposite post-central sensory cortex. Neurocysticercosis is a common cause of simple partial seizures in places where tape worm infestation is prevalent.

The other group of focal seizures includes those with impairment of consciousness or awareness and corresponds to the concept of complex partial seizure. These attacks generally consist of an aura followed by impaired consciousness and automatism. The aura may take many forms, e.g. sudden fear, unpleasant smell or taste, abdominal pain or tinnitus. Impaired consciousness may be brief and difficult to appreciate. The automatic behaviour frequently consists of abnormal repetitive movements, e.g. jaw movements, smacking the lips, eye fluttering or blinking, or staring, clasping or fumbling with the hands. Sudden difficulty in

speaking or incoherence is common. The most distressing features involve mental disturbances, e.g. violent tantrums, dream-like states or the *déjà vu* phenomenon (the mental impression that a new experience has happened before). Various types of visual, auditory or olfactory hallucinations may occur. There may be post-ictal confusion or sleepiness. This type of epilepsy is often difficult to diagnose in childhood because the young child is unable to describe the emotional or sensory elements of the seizures. It may take various forms, each rather bizarre and their epileptic basis should be indicated by their continued recurrence without obvious cause. The EEG typically shows a focal discharge from the temporal lobe, slow wave or spike-and-wave. Some children show spikes originating from other lobes. The most commonly described syndrome is mesial temporal lobe epilepsy with hippocampal sclerosis. This may be a sequel to perinatal hypoxia but status epilepticus itself, as in prolonged febrile convulsion, may be the asphyxial incident, which is followed by temporal lobe seizures. Other pathologies identified include hamartoma, vascular malformation, post-encephalitic gliosis and low-grade tumours.

Both these groups can evolve to a bilateral convulsive seizure which replaces the term 'secondarily generalised seizure'.

### **Diagnosis**

The first step is to make sure the child actually had a seizure. This depends on a careful history from a witness of the event and a thorough neurological examination. An EEG (electroencephalogram) is the most important investigation in the diagnosis and management of epilepsy as it helps in the categorisation of the epilepsy. A sleep deprived EEG improves the sensitivity in identifying abnormalities. The next important investigation is neuroimaging. Magnetic resonance imaging (MRI) is superior to CT (computed tomography) in identifying structural causes of epilepsy. Functional neuroimaging like SPECT (single photon emission computed tomography), PET (positron emission tomography) and fMRI (functional MRI) help in localising cerebral dysfunction and is currently supplementary to MRI.

Blood glucose and calcium measurement should be performed if an underlying provoking factor is suspected. Seizures in the first year of life or if associated with developmental delay will warrant a wider metabolic screen. Routine lumbar puncture is not indicated unless there is a reasonable suspicion of a CNS infection.

### **Differential Diagnosis**

Paroxysmal clinical events that mimic seizures are termed as nonepileptic seizures and this forms an important differential diagnosis for epileptic seizures. These are broadly grouped



as physiological nonepileptic seizures and psychogenic nonepileptic seizures. Conditions in the first category are many and in children they include breath-holding attacks, reflex anoxic seizures, syncope, tics, movement disorders, migraine, benign paroxysmal vertigo, narcolepsy, night terrors. Psychogenic nonepileptic seizures were earlier termed pseudoseizures.

### *Breath-holding Attacks*

These occur not infrequently in infants or toddlers and they are usually precipitated by pain, indignation or frustration. There are two types of breath-holding attacks, the more common cyanotic form and the less common pallid form also called as reflex anoxic seizures.

*Cyanotic breath-holding attacks:* Shortly after the onset of a fit of loud crying, the infant or toddler suddenly stops breathing in expiration and becomes cyanosed. If inspiration does not quickly follow the infant loses consciousness and goes rigid with back arched and extended limbs. He may have a few convulsive twitches. Respiration always starts again with rapid recovery and there is no danger to life. These attacks cease spontaneously as the child matures usually before 5 years of age. EEG shows no abnormality. The parents need to be reassured about its harmless nature and natural course. No specific treatment is necessary apart from correction of anaemia if present.

*Pallid breath-holding attacks (reflex anoxic seizure):* These occur in infants and children who have exaggerated vagal cardiac reflexes. Attacks may be precipitated by pain, which causes reflex cardiac asystole with sudden onset of extreme pallor, loss of posture and muscular hypotonia, and at times a tonic seizure. Recovery takes place as quickly as the onset with the resumption of ventricular contractions. No treatment is usually necessary. However if attacks are very frequent, oral atropine sulphate may be given.

*Syncope:* Neurocardiogenic syncope is the most common cause of transient loss of consciousness and is an important differential for epilepsy. It is also called vasovagal syncope and as the name implies is vagally mediated resulting in vasodilation and bradycardia. In the majority of cases there is a trigger in the form of prolonged standing, fear, severe pain or emotional distress. The child complains of light headedness, then loses body tone and falls with brief loss of consciousness up to 1–30 seconds and pallor. Convulsions occur in 70–90% of neurocardiogenic syncope and they may be myoclonus, tonic flexion or extension. The recovery is rapid with no post-ictal confusion. Diagnosis is established with a typical history and the tilt table test. In the majority of cases, treatment involves preventive measures like avoidance of trigger factors and adequate hydration. A few may require drug therapy.

*Psychogenic nonepileptic seizures:* These are paroxysmal seizure like events that occur as a result of psychological disturbances. The clues to diagnosis of psychogenic nonepileptic seizures are that they can be precipitated by stressful circumstances and in response to suggestion, they usually occur in the wakeful state and in the presence of witnesses, they lack stereotypicality, consciousness is retained throughout the event or shows fluctuation and the movements involve flailing of limbs, pelvic thrusting and eye closure. Attempts to open the eyes passively results in tightening of the eyelids. There is no actual post-ictal confusion and the events are resistant to antiepileptic medication. Psychogenic seizures are also very troublesome and can result in school absenteeism and distress to the entire family. Treatment involves gentle reassurance and involvement of a child psychiatrist.

## Treatment

### *General*

Most seizures are often self-limited and would have subsided by the time the child reaches a health care facility. If the child is still convulsing, airway respiration and circulation are first assessed and maintained. This is followed by prompt termination of seizure activity by administration of 0.1mg/kg IV Lorazepam or 0.2 mg/kg IV of Diazepam. If vascular access is not possible, rectal diazepam at 0.5 mg/kg or intranasal midazolam may be administered. Cessation of seizure is followed by the determination of the underlying cause and treatment of this where possible.

### *Anticonvulsants*

The majority of children with a first unprovoked seizure will not have a recurrence. Hence anti-epileptic drug treatment should not be commenced routinely after a first unprovoked tonic-clonic seizure. Risk factors for recurrence include remote symptomatic aetiology, abnormal EEG, a history of prior febrile convulsions and age less than three years. In newly diagnosed epilepsy, the aim of the treatment is to control, or prevent if possible, the recurring seizures, and to achieve this with one drug. The choice of the antiepileptic drug should be determined where possible by the syndromic diagnosis and potential adverse effects. Generalised tonic clonic seizures can be treated with sodium valproate, carbamazepine, phenytoin or phenobarbitone. Ethosuximide and sodium valproate are both effective in controlling absence epilepsy. Myoclonic epilepsy is usually treated with sodium valproate or clonazepam. The first line drug in focal seizures is carbamazepine. However sodium valproate, phenytoin, lamotrigine, levetiracetam, clobazam, oxcarbazepine and vigabatrin are all effective as monotherapy in the treatment

of focal seizures. In drug resistant generalised epilepsy, clobazam, clonazepam and lamotrigine are effective as add-on treatments. Lamotrigine, gabapentin, topiramate, oxcarbazepine and levetiracetam are effective as add-on therapies for focal seizures.

The treatment of infantile spasms (West's syndrome) is unsatisfactory; they are resistant to most conventional anticonvulsant drugs, although they sometimes cease spontaneously with time. At present, corticotrophin (ACTH) or corticosteroids is recommended as first line treatment. The therapeutic efficacy of these two drugs is relatively equal and one may be effective if the other drug fails. ACTH is given intramuscularly in doses of 40 units/day and prednisolone is given orally in doses of 20–30 mg/day. A 21-day course of treatment is usually sufficient; although in some cases prolonged but reduced dosage is necessary. In West's syndrome secondary to tuberous sclerosis, vigabatrin is superior. Benzodiazepines like clonazepam and nitrazepam are the alternative drugs for the treatment of infantile spasms.

Adverse effects from antiepileptic drugs are common and are a major cause of discontinuing drug treatment. Many adverse effects are dose related and predictable. These can be minimised by gradual escalation of the dose, regular monitoring of the serum concentration of the drug and appropriate dose reduction. Idiosyncratic drug reactions usually arise early in treatment. Rash is a common adverse effect in children and is associated with carbamazepine, phenytoin and lamotrigine. Rarely, a severe hypersensitivity syndrome may occur which may be life-threatening. Sodium valproate has very little sedative action. The dosage is 20–30 mg/kg per day given in a twice-daily dose. Adverse reactions include mild nausea, vomiting and transient alopecia. Significant weight gain can occur. In a few children it has caused acute liver failure and pancreatitis. The value of estimating the serum concentration of valproate is less than for other drugs as it seems to have a longer action than its half-life (4–14 hours) would suggest. Tremor and thrombocytopenia are dose related side effects. Carbamazepine rarely causes drowsiness and has considerable advantage for children and adolescents, in whom learning ability is very important. It may cause ataxia if started in full doses too abruptly. The usual dose is 10–20 mg/kg per day given in 2–3 divided doses started at a lower dose and increased gradually. Phenytoin is given in a dose of 5–10 mg/kg/day in 2 divided doses. There are many interactions between phenytoin and other drugs. Over dosage results in ataxia and it is helpful to monitor serum concentration. An unwelcome although reversible side effect is hypertrophy of the gums, seen in a sizeable proportion of patients. Prolonged medication can result in hirsutism, coarsening of the facies towards an acromegaloid appearance and acne. Very rarely in children it causes megaloblastic anaemia responding to folic acid. The

major side effects of benzodiazepines are behavioural with clobazam and clonazepam causing over activity, aggression, sleep disturbance and poor concentration. In some children excessive sedation and hypotonia occur. Development of tolerance to their antiepileptic effects is another problem. Clonazepam is started with a single evening dose of 250–500 micrograms gradually increasing to a daily dose of 0.1–0.2 mg/kg per day in three divided doses. Phenobarbitone causes impairment of cognitive function, drowsiness, restlessness and behaviour disturbances in a fair proportion of patients. Antiepileptic drugs have teratogenic side effects.

Overall, 60–70% of the children who have been seizure free on drugs for two years or more will remain seizure free when the drugs are withdrawn. Sudden discontinuation of antiepileptic drugs, particularly phenobarbitone and benzodiazepines should be avoided.

### Status Epilepticus

Status epilepticus being a medical emergency requires rapid and a stepwise approach to treatment. Parents of children who have a tendency to develop status epilepticus should be taught to start treatment at home itself. Benzodiazepines are the preferred drug for the initial management. This would include buccal or intranasal midazolam (0.2 mg/kg) or rectal diazepam (0.3 mg/kg). Once in the emergency room, after the initial stabilisation with giving oxygen, stabilising airway, respiration and haemodynamics, IV access is obtained and Lorazepam (0.1 mg/kg) is given. Care is taken to avoid hypoglycaemia, hyperglycaemia and hyperthermia. At least two doses of the benzodiazepine are given. If seizures persist, the second line anticonvulsant is administered and this may be Fosphenytoin or Phenytoin (up to 20 mg/kg per dose). If seizures continue 10 minutes after this, the third line anticonvulsants are administered, which may be IV Levetiracetam or Sodium valproate or Phenobarbitone. Meanwhile further investigations like a complete blood count, basic metabolic panel, liver function tests are carried out. If seizures persist beyond this level, it is termed refractory status epilepticus and the child is admitted to the paediatric intensive care unit for initiation of pharmacologic coma with midazolam or if refractory to this as well, then thiopentone or pentobarbital or propofol is initiated. Status epilepticus needs management in a tertiary care centre and needs referral after the initial stabilisation.

### Social Management

A child with epilepsy whose convulsion can be prevented or rendered infrequent should attend an ordinary school and live as normal a life as possible. The physician must by explanation and advice bring the parents to accept the need for an unrestricted existence and even to accept a few risks.

Certain restrictions such as riding a bicycle in the city streets or swimming unsupervised are clearly unavoidable, but they should be reduced to the minimum. For many children and their families, social and psychological factors far outweigh those problems associated with the prevention and control of seizures. Families who have a child with epilepsy should be given clear, accurate and appropriate information about the condition, its treatment and the implication for everyday living. A multidisciplinary approach provided within a specialist clinic, with support and advice from a clinical nurse specialist, with help from relevant voluntary support organisations and occasionally from psychologists and psychiatrists has proved helpful to some families. Special schooling may be necessary for the learning-impaired child with epilepsy. Schools should be given written information on epilepsy and its management.

## FEBRILE SEIZURES

Febrile seizures are convulsions precipitated by fever, not due to an intracranial infection or other definable CNS cause. Febrile seizures are the most common type of seizures during childhood with an incidence of 3–4%. They are age dependent and occur between 6 months and 5 years of age and are precipitated by a rapid rise of temperature to 39°C or greater due to viral fever, URI, acute otitis media, etc. in the early course of the fever. There may be a family history of febrile seizure in parents or siblings.

### Clinical Features

Febrile seizures are classified as simple (85%) or atypical/complex (15%). The majority (simple) seizures are typically brief generalised tonic-clonic seizure lasting a few seconds to a few minutes followed by full recovery. Febrile seizures are considered as atypical/complex when the duration of seizure is longer than 15 minutes, repeated convulsions occur within the same day, when the seizure is focal or post-ictal focal deficit is noted. Febrile seizure lasting more than 30 minutes may be called febrile status and may leave a sequel, if untreated; particularly temporal lobe epilepsy due to mesial temporal sclerosis.

The risk of recurrence of febrile seizure is 30%. Most recurrences occur within the first year of the first febrile seizure. The future risk of epilepsy is 1% in simple febrile seizure and 9% when two or more risk factors are present. The risk factors are atypical febrile seizure, a positive family history of epilepsy, an initial febrile seizure before 9 months of age, delayed developmental milestones or a pre-existing neurological disorder. Intermittent prophylaxis with clobazam in a dose of 0.5 mg/kg per dose q12h × 2 days at the onset of fever has been found to decrease the chance of

recurrence of febrile seizures. High-risk cases with several risk factors may be given sodium valproate (20–40 mg/kg per day) or phenobarbitone (3–5 mg/kg per day) for one and half years to two years.

## CHILDHOOD STROKE

Childhood stroke is defined as a cerebrovascular event occurring between 28 days and 18 years of age. This encompasses ischaemic stroke and haemorrhagic stroke. Ischaemic stroke includes arterial ischaemic stroke and cerebral venous sinus thrombosis while haemorrhagic stroke includes spontaneous intracerebral haemorrhage and non traumatic subarachnoid haemorrhage. The annual incidence of stroke ranges from 1.5–2.5 per 100,000 children and of this 50% are arterial ischaemic stroke, 40% haemorrhagic stroke and the rest venous sinus thrombosis. The causes for childhood stroke are many (Table 18.3). One-third of them have an underlying disease, one-third have vascular malformations and in the rest the aetiology remains unclear. Often more than one risk factor is identified.

### Clinical Features

The clinical presentation depends on the territory of ischaemia or bleed. As a rule children with arterial ischaemic stroke present with sudden onset focal neurological deficits without major alteration of consciousness unlike more common paediatric illnesses like encephalitis, complex partial and generalised seizures which often have alteration of awareness. Focal neurological deficits could include hemiparesis, visual field defects, aphasia, cranial nerve palsies, dysphagia and unilateral ataxia. Anterior circulation infarcts are more common. Larger strokes tend to have multiple deficits and alteration of consciousness.

Haemorrhagic strokes have a much more dramatic presentation with alteration of consciousness, nausea, vertigo, vomiting, headache and seizures.

Children with venous sinus thrombosis have protracted severe headache with vomiting as their starting symptoms followed by focal neurological deficits and seizures when they go onto develop venous infarction.

The underlying disease, if already known, will give a clue to the type of stroke. For example arterial ischaemic stroke is seen in children with cardiac diseases, chronic meningitis like tuberculosis, varicella infection and haemoglobinopathies. Thrombosis of the internal carotid artery may result from trauma caused by falls on objects, e.g. a pencil in the mouth, which penetrates the tonsillar fossa. Children with bleeding disorders are more likely to have haemorrhagic strokes and children with dehydration, nephrotic syndrome and older girls on oral contraceptive pills are likely to develop venous sinus thrombosis.

**Table 18.3:** Causes of childhood stroke

<i>Arterial ischaemic stroke</i>	
Cerebral arteriopathy	Moyamoya disease Moyamoya syndrome Focal cerebral arteriopathy of childhood Post-varicella arteriopathy Vasculitis Isolated CNS vasculitis Post-infectious Arterial dissection
Cardio-embolic	Congenital heart disease Acquired heart disease
Haematological	Sickle cell disease Iron deficiency anaemia Thrombocytosis Protein C/S deficiency Factor V Leiden mutation MTHFR mutation
Undetermined aetiology	
<i>Haemorrhagic stroke</i>	
Arteriovenous malformation	
Cerebral aneurysm	
Bleeding disorders	
<i>Cerebral venous sinus thrombosis</i>	
Dehydration	
Hypercoagulable disorders	
Iron deficiency anaemia	

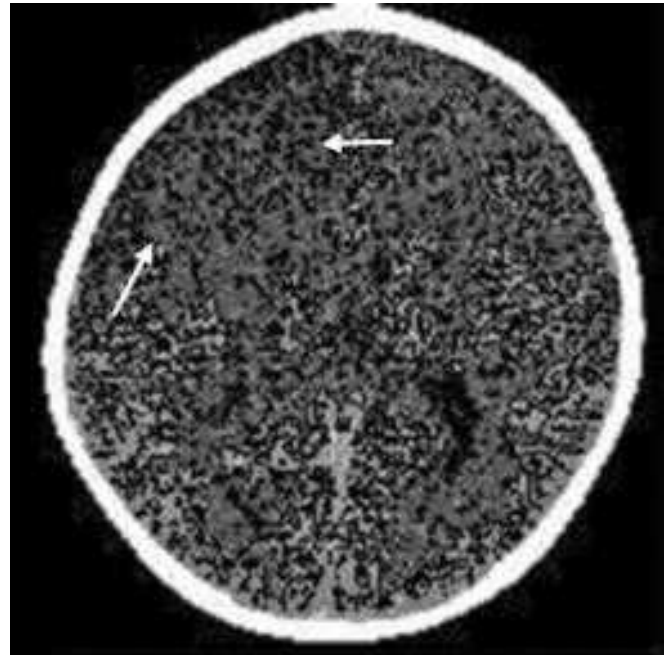
### Stroke Mimics

Acute onset of focal neurological deficit in a child need not be due to a cerebrovascular event and can have multiple other aetiologies. These are called stroke mimics and the differential diagnosis for this includes infectious or inflammatory causes like encephalitis, *Haemophilus influenzae*, meningitis, tuberculous meningitis, brain abscess from middle ear infection or congenital heart disease and demyelination like acute disseminated encephalomyelitis. Prolonged focal seizures can cause a temporary paralysis called Todd's paresis which can persist for up to 48–72 hours. Metabolic disorders associated with focal neurological deficits include hypoglycaemia, MELAS, homocystinuria and Fabry disease.

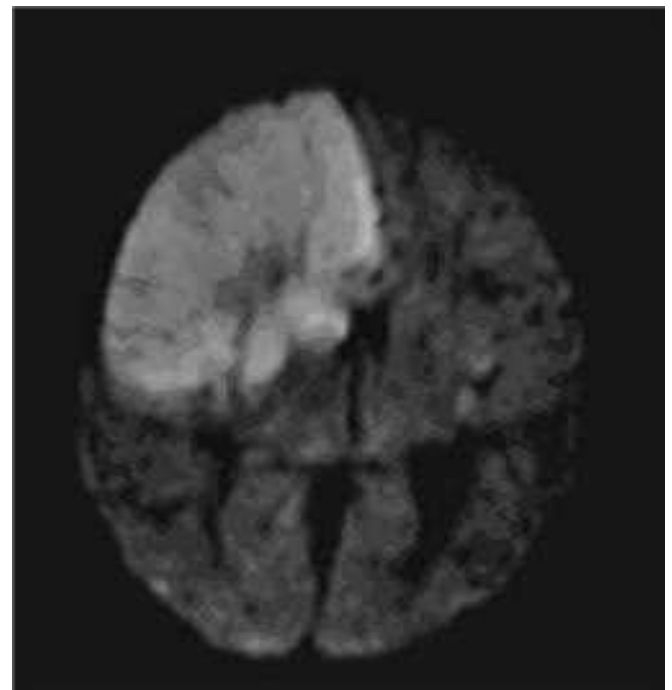
### Diagnosis

Diagnostic evaluation needs to be extensive firstly to differentiate strokes from stroke mimics and secondly to determine the cause of the cerebrovascular event. In the acute stage, a plain CT (computerised tomography) brain will help to identify haemorrhage, abscess and tumours. This has to be followed by a MRI of the brain with diffusion-weighted images (Figs 18.5 A and B) to assess acute ischaemic zones.

Vascular imaging also needs to be performed along with this like magnetic resonance angiography (MRA) (Figs 18.6 and 18.7) and magnetic resonance venography (MRV). MRA will demonstrate arteriopathy, dissection, stenosis,



**Fig. 18.5A:** CT brain of a 12-year-old showing acute infarct involving the right internal carotid (IC) artery territory. Note the loss of grey white differentiation

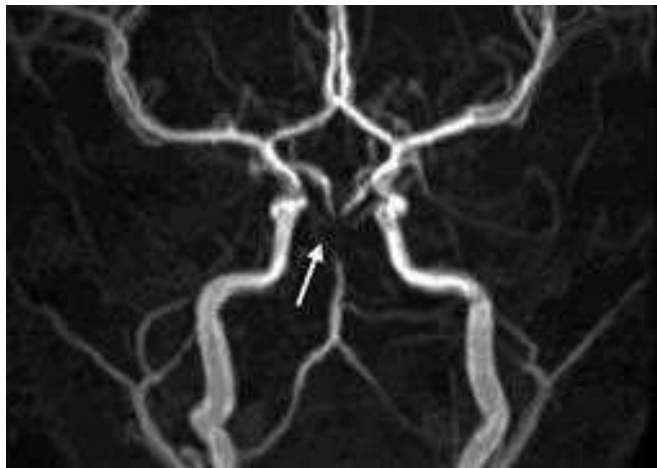


**Fig. 18.5B:** Diffusion-weighted imaging of the same child showing restricted diffusion in the right IC territory

irregular contour or intra-arterial thrombosis of the head and neck and MRV will demonstrate cerebral venous sinus thrombosis. Further vascular imaging in the form of CT angiography or conventional angiography is warranted if further neurovascular intervention is planned.

For arterial ischaemic stroke, transthoracic echocardiography is another important diagnostic imaging to detect congenital or acquired cardiac anomalies including patent foramen ovale.

Diagnostic laboratory evaluation has to include complete blood count, complete metabolic panel, and erythrocyte

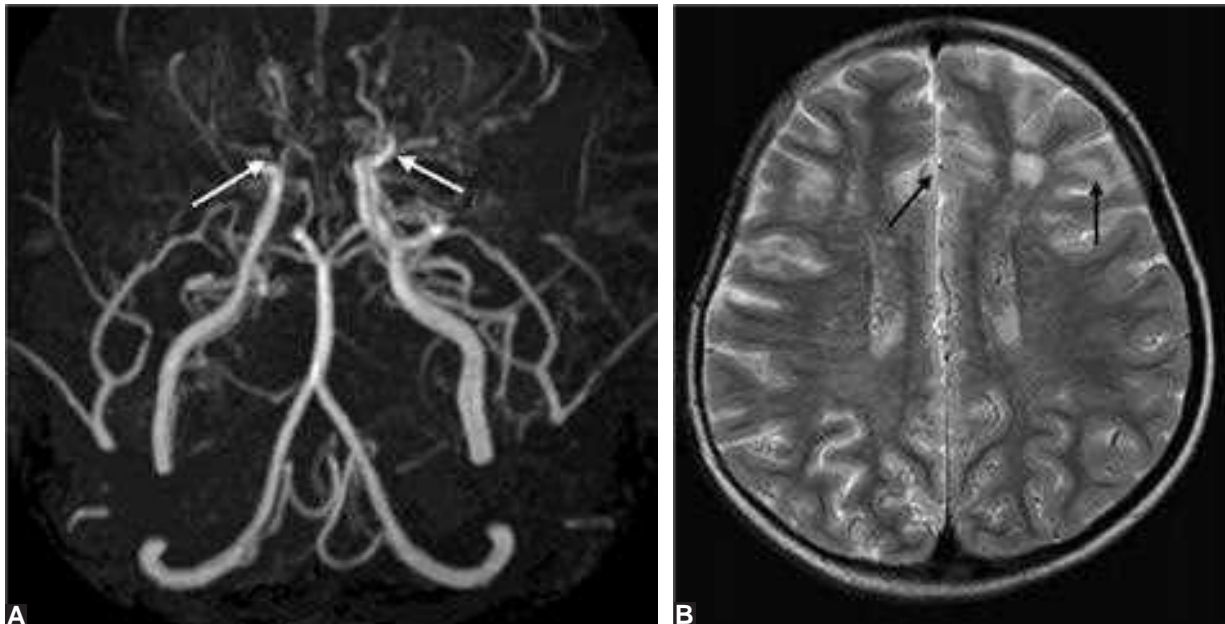


**Fig. 18.6:** MR angiogram of a 9-year-old child with posterior circulation stroke following varicella infection, showing focal narrowing of the basilar artery (arrow)

sedimentation rate, C-reactive protein to assess biochemical evidence of systemic inflammation which could suggest vasculitis or infection and complete thrombotic profile. If vasculitis is suspected, rheumatological evaluation like testing of antinuclear antibody, rheumatoid factor should be considered. A lumbar puncture is indicated if infectious or inflammatory states are considered and in this it would be advisable to perform routinely test for herpes simplex virus (HSV), varicella zoster virus (VZV) and other enteroviruses.

### Treatment

Initial treatment of childhood stroke involves supportive measures like airway stabilisation, administration of oxygen, maintenance of euglycaemia and treatment of seizures if present. The acute and maintenance treatment guidelines for childhood strokes are based on consensus, cohort studies and extrapolation from adult studies. Treatment of stroke with sickle cell disease requires exchange transfusion to reduce haemoglobin S to levels less than 30% for acute stroke and continue blood transfusions every 3–6 weeks to keep HbS less than 30%. Commonly childhood arterial ischaemic stroke is treated with unfractionated heparin (UFH) or low molecular weight heparin (LMWH) for 5–7 days and until cardioembolic stroke or dissection is excluded. Oral anticoagulation is continued for a further 6 months in cases of cardioembolic stroke and dissection. Vasculopathy including moyamoya disease and syndrome are treated with



**Figs 18.7A and B:** MR angiogram of a 7-year-old child showing supraclinoid narrowing (white arrows) of both the internal carotid artery with multiple distal collaterals. The T2W image of the same child shows bilateral frontal infarcts (black arrows)



**Fig. 18.8:** Post-gadolinium sagittal image of the brain of a 5-year-old with nephrotic syndrome who presented with two week history of severe holocranial headache and MRI showing filling defect in the superior sagittal sinus (arrow) suggestive of cerebral venous sinus thrombosis

oral aspirin (1–3 mg/kg per day) both in the acute phase as well as in the maintenance phase. Moyamoya syndrome is eventually treated with neurosurgical approach aimed at revascularisation. There is still not enough evidence for use of intravenous and intra-arterial thrombolytic therapy in acute arterial ischaemic stroke in childhood.

Cerebral venous sinus thrombosis (Fig. 18.8) is treated initially with UFH or LMWH for 5–7 days and then oral anticoagulation for another 3–6 months.

Haemorrhagic strokes are referred to the neurosurgical team for possible evacuation of the hematoma. This is followed by specific surgical treatment for the aneurysm or arteriovenous malformation (AVM).

### Prognosis

The risk for recurrence varies approximately between 20% and 40%. Recurrence risk is increased in those with a specific coagulation abnormality or vasculopathy. Long-term sequelae of the stroke itself includes residual neurologic deficits, learning disabilities, seizures and cognitive impairments. This depends on the location and extent of cerebrovascular insult and other comorbid conditions. This, in turn, requires long-term rehabilitative and neuropsychological input.

## MOVEMENT DISORDERS

The control of voluntary movement is affected by the interaction of the pyramidal, extra-pyramidal and cerebellar systems. The effects of disease of the extra-pyramidal system on movement are bradykinesia, rigidity, postural disturbance and involuntary movements namely chorea, athetosis, tremor and dystonia. Chorea is a jerky, semi-purposive, non-repetitive involuntary movement affecting the limbs, face and trunk. Causes of chorea in childhood include rheumatic chorea, extra-pyramidal cerebral palsy, Wilson's disease and post-encephalitic sequelae.

### Wilson's Disease

This disease, inherited as an autosomal recessive trait, is an inborn error of copper metabolism resulting in an excessive accumulation of copper in the liver, brain, cornea and other tissues. The gene for Wilson's disease has been mapped to chromosome 13.

### Clinical Features

Hepatic presentation in the form of jaundice, hepatomegaly, cirrhosis or portal hypertension, is predominant in children younger than 10 years of age. Neurological presentation is predominantly in older children with basal ganglia lesion, e.g. coarse tremors of the extremities (wing-beating tremor), dystonia, dysarthria, dysphasia, drooling, emotional instability, deterioration in school performance and dementia (Fig. 18.9). A characteristic finding is the Kayser-Fleischer ring, a golden brown discoloration due to deposition of copper at the corneal limbus (Fig. 18.10).



**Fig. 18.9:** Dystonic posture in a child with Wilson's disease

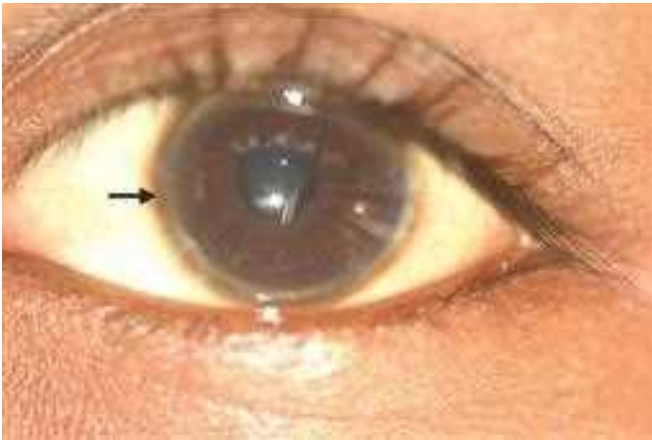


Fig. 18.10: Kayser-Fleischer Ring

### Diagnosis

The serum ceruloplasmin level is decreased and urine copper excretion is increased particularly after a 1gm D-penicillamine challenge test. Liver function is usually deranged and slit-lamp examination of the eyes reveals K-F ring. Liver biopsy may reveal cirrhosis and excessive copper content.

### Treatment

Early treatment with chelating agent can show marked improvement. Oral D-penicillamine is given in doses of 500 mg to 2 gm/day; the drug should be continued for life. Zinc reduces copper absorption and 100–150 mg/day can be given as an adjuvant therapy. A low-copper diet (excluding cocoa, nuts, liver, shellfish, mushrooms and spinach) is also advised. It is essential to screen siblings of patients with Wilson's disease.

## RHEUMATIC CHOREA (SYDENHAM'S CHOREA, ST. VITUS DANCE)

This major manifestation of rheumatic fever may occur in association with other manifestations such as polyarthritis and carditis but it frequently appears as a solitary and rather odd phenomenon. It is, in fact, the only major rheumatic manifestation which can affect the same child more than once, and sometimes several times, without the development of any of the other manifestations of acute rheumatic fever. For these reasons and also because the ESR and ASO titre remain normal in uncomplicated chorea, the precise relationship of this disease to rheumatic fever has been the subject of an unresolved controversy. It is more common in girls. The clinical features fall into four main groups.

1. Involuntary purposeless, non-repetitive movements of the limbs, face and trunk, e.g. grimacing, wriggling and writhing. The movements can be brought under voluntary control temporarily. They are aggravated by excitement and they disappear during sleep. The first indication may

be that the child begins to drop things or her handwriting suddenly deteriorates or she gets into trouble with her elders for making faces. Sometimes the movements are confined to one side of the body (haemichorea).

2. Hypotonia may result in muscular weakness. It also causes the characteristic posture of the outstretched hands in which the wrist is slightly flexed, whereas there is hyperextension of the metacarpophalangeal joints. Occasionally the child is unable to stand or even to sit up (chorea paralytica).
3. Incoordination may be marked or only obvious when the child is asked to pick a coin off the floor.
4. Mental upset is often an early sign. Emotional lability is almost constant. School work usually deteriorates. Infrequently the child becomes confused or even maniacal (chorea insaniens).

As regards the management of rheumatic chorea carbamazepine, haloperidol, sodium valproate and prednisolone have been tried. Prophylactic chemotherapy with penicillin is required as for rheumatic fever.

## NEUROCUTANEOUS SYNDROMES

Neurocutaneous syndromes (The Phakomatoses) are disorders with manifestation in skin and central nervous system. Most are autosomally inherited and have a high rate of tumour formation. The common phakomatoses are neurofibromatosis, tuberous sclerosis, Sturge-Weber syndrome, von Hippel-Lindau disease and ataxia telangiectasia.

## NEUROFIBROMATOSIS (VON RECK-LINGHAUSEN'S DISEASE)

This is the commonest neurocutaneous syndrome and is transmitted as an autosomal dominant characteristic. There is abnormality of neural crest migration. Two gene defects have been identified; one on chromosome 17 which leads NF-I with mainly cutaneous features and peripheral nerve abnormalities, and the other on chromosome 22 with mainly central nervous system involvement and acoustic neuroma formation after the age of 20.

The earliest and pathognomonic signs of neurofibromatosis are the café-au-lait spots or patches which are irregularly shaped hyperpigmented brownish macules often present at or shortly after birth and may vary in size and number with age. Presence of six or more café-au-lait spots greater than 0.5 cm in diameter in prepubertal children is considered diagnostic of neurofibromatosis. Other cutaneous manifestations are axillary or inguinal freckling and presence of pedunculated neurofibromas. Palpable neurofibromata are to be detected along the course of subcutaneous nerves. The brain may be the site of formation of hamartomatous nodules, and various types of tumours (glioma, ependymoma, meningioma) may

occur in the brain, optic nerve, spinal cord or spinal nerve roots. Approximately 10–20% of the patients manifest with seizures, intellectual deficit and speech and motor delay. Lisch nodules are seen in the iris with increasing age. Osseous lesions include progressive kyphoscoliosis in childhood, sphenoidal dysplasia and cortical thickening of long bones with or without pseudarthrosis.

### Treatment

There is no specific treatment and therapy is symptomatic and includes genetic counselling and early detection of treatable complication. Neurosurgical intervention is often necessary to remove symptomatic tumours of the central and peripheral nervous system.

## TUBEROUS SCLEROSIS (EPILOIA)

Tuberous sclerosis is one of the phakomatoses with manifestations in the skin, central nervous system, and eye as well as hamartomata of internal organs such as kidney, heart, lung and bone. The disease is transmitted as an autosomal dominant trait with gene defects identified on chromosomes 9 and 16. Seizures are the commonest presenting symptom and may present in infancy with infantile spasms or partial seizures. Hypopigmented areas of skin, sometimes assuming an ash-leaf shape, are the earliest skin manifestation (Fig. 18.11). The characteristic rash of butterfly distribution and papular character on the face and nose known as adenoma sebaceum appears later (Fig. 18.12). Other skin lesions include shagreen patch—a leathery plaque—usually in the lumbosacral area and café-au-lait spots.

The characteristic brain lesion consists of tubers typically present in the subependymal region made of abnormal



Fig. 18.11: Tuberous sclerosis. Hypopigmented macule



Fig. 18.12: Tuberous sclerosis. Adenoma sebaceum in a characteristic malar distribution and chin lesions as well

giant cells and sclerosis due to overgrowth of astrocytic fibrils. These tubers undergo calcification and also at times malignant transformation. Mental retardation is a common feature. Ophthalmoscopy may show characteristic yellowish-white phakomata on the retina. The heart may be the seat of a rhabdomyoma or tubers. In some cases there are teratomata or hamartomata of the kidneys, liver, bone and lung.

The diagnosis of tuberous sclerosis is based on the combination of characteristic cutaneous lesions, seizures, intellectual deficit and visceral tumours. Neuroimaging studies demonstrate subependymal-calcified nodules adjacent to lateral ventricles. (see chapter 32: Figs. 32.108 and 109) The white matter in cerebral lesions is either calcified or hypodense. There is no specific treatment for tuberous sclerosis. Management consists mainly of seizure control and genetic counselling. Infantile spasm associated with tuberous sclerosis is best treated with vigabatrin.

## STURGE-WEBER SYNDROME (ENCEPHALOFACIAL ANGIOMATOSIS)

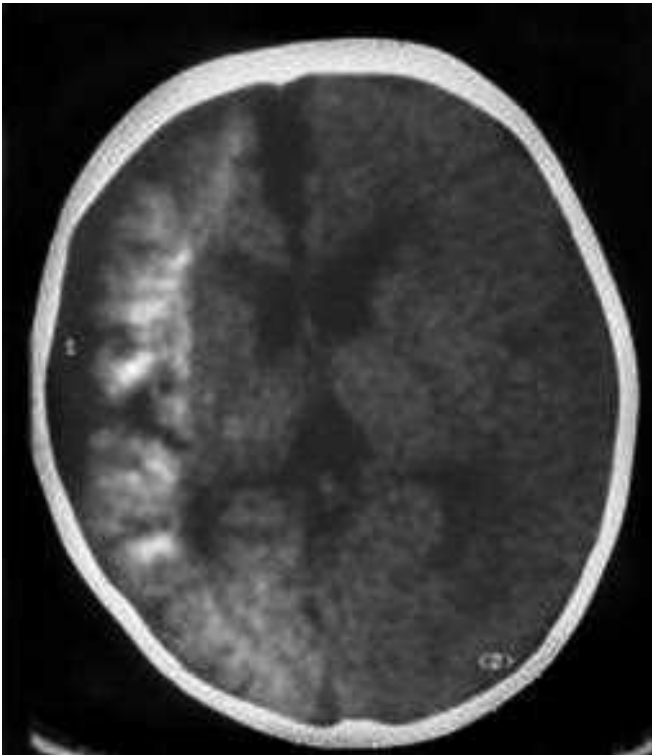
This disease consists of cutaneous port-wine haemangioma of the upper face and scalp, which is predominantly limited by the midline, and a similar vascular anomaly of the underlying leptomeninges on the same side (Fig. 18.13). The brain beneath becomes atrophic and calcified particularly in the occipital and parietal regions (Fig. 18.14). The mode of inheritance of this disease is not clear.

The port-wine stain is present at birth. Convulsions confined to the contralateral side of the body develop in infancy. In time a spastic hemiparesis and hemiatrophy may develop on the contralateral side. Mental deterioration ultimately





**Fig. 18.13:** Sturge-Weber syndrome. Port-wine non elevated cutaneous haemangioma in a trigeminal distribution, including the ophthalmic division



**Fig. 18.14:** Sturge-Weber syndrome. CT scan showing intracranial calcification

appears and progresses. Glaucoma may also develop in the ipsilateral eye and require surgical intervention. Radiographs of the skull in later childhood show a characteristic double contour or “tramline” type of calcification.

Treatment is symptomatic and directed at control of seizures and glaucoma. If seizures are refractory to drug therapy surgical resection of the affected lobe or hemispherectomy may be indicated. In some cases the facial naevus can be corrected by cosmetic laser surgery.

### ATAXIA-TELANGIECTASIA (LOUIS-BAR SYNDROME)

Ataxia telangiectasia is characterised by progressive cerebellar ataxia, oculocutaneous telangiectasia, choreoathetosis, recurrent sinopulmonary infections, and immunological dysfunction. It is an autosomal recessive condition with the abnormal gene located to chromosome 11. The first symptom to appear is a progressive cerebellar ataxia beginning in the second or third year of life. There may be, in addition, choreoathetotic movements and a tendency to turn the eyes upwards when focusing. Telangiectasia appear between the ages of 3 years and 7 years. They are found on the bulbar conjunctiva, malar-eminences, ears and antecubital fossa. These children suffer severely from infections of the sinuses and lungs; indeed bronchiectasis is a frequent cause of death. They have a much higher risk of developing lymphoreticular malignancy. These are explained by abnormalities of immunologic function resulting in reduction of serum and secretory IgA, IgE, IgG2 and IgG4. There is hypoplasia of the thymus and cellular immunity is also impaired. Alpha-fetoprotein level is elevated. There is no specific treatment. Infection should be controlled with suitable antibiotics. In malignant change, steroids may give temporary relief.

### VON HIPPEL-LINDAU DISEASE

This is a rare autosomal dominant inherited disorder characterised by haemangiomas cystic lesions in the retina and cerebellum, sometime also in spinal cord, kidney, liver and pancreas. It may present with the signs of a cerebellar tumour (progressive ataxia and raised intracranial pressure) or with loss of vision due to retinal detachment. Renal carcinoma and pheochromocytoma are frequently associated. Surgical treatment is indicated for the cerebellar and visceral tumours and photocoagulation and cryocoagulation for the retinal angiomas.

### NEURODEGENERATIVE DISORDERS

These are rare progressive degenerative disorders that usually result from specific genetic and biochemical defects. The characteristic features are loss of developmental milestones, intellect, speech and vision often associated with seizures. They may affect primarily the grey matter, i.e. cortical neurones resulting in early symptoms of seizures

and intellectual deterioration, or the white matter with early pyramidal tract involvement.

## NEURONAL CEROID LIPOFUSCINOSES

These are autosomal recessive disorders characterised by accumulation of autofluorescent intracellular lipopigment. There are three clinical types namely infantile type, late infantile type and juvenile type. In the types with onset in infancy, myoclonic seizures are a prominent feature with progressive loss of vision and developmental milestones.

The white matter degenerative diseases (leukodystrophies) include metachromatic leukodystrophy, Krabbe's globoid body leukodystrophy, adrenoleukodystrophy and Schilder's disease.

### Metachromatic Leucodystrophy

This autosomal recessive disorder is characterised by accumulation of cerebroside sulphate in the white matter of the brain, the peripheral nerves, the dentate nucleus, basal ganglia and in other organs such as the kidneys due to the deficiency of the enzyme arylsulphatase A. There is a widespread demyelination with neuronal and axonal loss. The sulphatide stains metachromatically with basic polychrome dyes. Three clinical forms of the disease have been described.

1. *Late infantile form*: This is the most common type with its onset between 6 months and 24 months. Deterioration in walking due to progressive and mixed pyramidal and cerebellar damage is soon followed by deterioration in speech and social development, loss of the ability to sit or feed without help, fits, misery and withdrawal, finally a decorticate posture leading to death some 5 months or longer from the onset.
2. *Juvenile type*: This has an onset between 6 years and 10 years. The first signs are educational and behavioural deterioration, followed after some months or years by disorders of gait mostly extrapyramidal with some pyramidal signs. Progress towards dementia and death may take more than 5 years.
3. *Adult type*: Onset 16 years to adulthood. Psychiatric changes predominate.

### Krabbe's Globoid Body Leucodystrophy

Krabbe's globoid body leucodystrophy is characterised by accumulation of globular bodies in white matter due to deficiency of the enzyme galactocerebroside  $\beta$ -galactosidase. The onset is in early infancy with incessant crying followed by apathy. Generalised rigidity, seizures, head retraction, blindness, inability to swallow and death may ensue in a year or so. Peripheral nerve involvement may cause absent deep tendon reflexes.

### Adrenoleukodystrophy

This is an X-linked recessive disorder with onset usually between 5 years and 15 years of age with progressive psychomotor deterioration, ataxia, dementia, loss of vision and hearing. There is an evidence of adrenocortical insufficiency with skin pigmentation. The blood level of very long chain fatty acid is increased. Death occurs within 10 years of the onset. Bone marrow transplant at an early stage is helpful.

### Heredodegenerative Ataxias

These are inherited progressive ataxias. The commonest type is Friedrich ataxia, which is an autosomal recessive disorder with the abnormal gene located in chromosome 9. The onset of symptoms is in childhood and before puberty with pes cavus, kyphoscoliosis and ataxia. There is nystagmus and intention tremor. Involvement of the dorsal columns leads to the loss of vibration and position sense. The deep tendon reflexes are absent, particularly ankle jerk and the plantar response is extensor. Optic atrophy and dysarthria may appear late in the course of the disease. Cardiac involvement can lead to intractable congestive cardiac failure. Death may be delayed for 10–15 years, but it may occur earlier from cardiac failure.

### Hereditary Motor-Sensory Neuropathies

this group of progressive degenerative disorders of the peripheral nerves affects predominantly the motor nerves, and sensory and autonomic involvement appears later.

### Charcot-Marie-Tooth Peroneal Muscular Atrophy

This disease starts in late childhood with progressive weakness and lower motor neurone type of flaccid atrophy of the peroneal and tibial muscles and of the small muscles of the feet resulting in paralytic talipes equinovarus. Later, wasting of the calf muscles gives the legs an inverted wine-bottle appearance. At a late stage, weakness and wasting affect the hands and forearms. The ankle jerks are lost but the knee jerks remain brisk. Sensory involvement is manifested by some loss of vibration and positional sensation. Most cases are transmitted as autosomal dominant.

## NEUROMUSCULAR DISORDERS

### SPINAL MUSCULAR ATROPHY (SMA)

The principal feature of this disease is progressive degeneration and loss of motor neurons in the anterior horns of the spinal cord. It is caused by homozygous disruption of the survival motor neuron 1 (SMN1) gene by deletion, conversion, or mutation located on chromosome 5q13. It is a

relatively common disease of infancy inherited as a recessive trait. There are four clinical types differentiated by age of onset and severity of weakness.

### **SMA Type 1 (Werdnig-Hoffman Disease)**

This is the most severe form and may be present at birth or appear within a few weeks. Its onset in utero may be recognised by the mother because of decreased foetal movements. There is severe flaccidity and weakness of the muscles of the trunk and limbs. The proximal muscles tend to be more severely paralysed than the distal. The deep tendon reflexes are absent. Fasciculation in the muscles of the tongue may be seen. The infant has an alert expression. When the intercostal and other accessory muscles of respiration become affected dyspnoea, intercostal recession and paradoxical respiration develop. Eventually the diaphragm is involved rendering the infant prone for chest infection and respiratory failure. The loss of power to suck further aggravates the terminal stages of the illness. Death usually occurs before 2 years of age. There is no specific treatment.

### **SMA Type 2 (Intermediate Type)**

This type has a later onset between 7 months and 18 months of age. There is progressive weakness with severe wasting leading to deformities particularly scoliosis. They are able to sit but rarely learn to walk and are confined to wheelchair. Deaths occur before 10 years of age.

### **SMA Type 3 (Kugelberg-Welander Syndrome)**

This is a milder type of paralysis with onset after the age of 2 years and is compatible with a prolonged course. There is proximal muscle weakness involving the pelvic and shoulder girdle muscles. Skeletal deformities readily develop. In some cases, the bulbar muscles become involved. These children may learn to walk, but ultimately become confined to a wheelchair. They may live up to middle age.

### **SMA Type 4 (Adult Type)**

Adults have this disease onset usually in the second or third decade. Motor impairment is mild and they continue to walk with no respiratory complications.

Electromyography shows features of denervation with positive sharp waves, fibrillation and occasional fasciculations. Motor unit action potentials show high potentials with decreased recruitment. Muscle biopsy shows atrophic fibres with islands of group hypertrophy.

Treatment is currently aimed at good rehabilitation, prevention of scoliosis and respiratory infections. Trials are on to improve functioning of the SMN protein through non-toxic molecules. Motor neurons derived from stem cells are also being tried in animal trials.

Spinal muscular atrophy has to be differentiated from other causes of “floppy infant syndrome”, the causes for which include central hypotonia like cerebral malformations, muscle disorders like congenital myopathy and disorders of neuromuscular junction like congenital myasthenic syndrome.

In benign congenital hypotonia, hypotonia dates from or soon after birth. The deep tendon reflexes although sluggish can usually be elicited and muscle fibrillation is not seen. The true diagnosis of benign congenital hypotonia becomes clear with the passage of time (5–9 years), when slow but not always complete recovery takes place. Muscle biopsy is normal in benign congenital hypotonia.

## **MUSCULAR DYSTROPHY**

Muscular dystrophies are a group of inherited disorders characterised by progressive degeneration of muscle fibres.

### **Duchenne's Muscular Dystrophy**

This is the commonest type of muscular dystrophy. It is inherited as X-linked recessive trait with a high new mutation rate. The abnormal gene is located at Xp21 locus on the X-chromosome, which leads to deficiency of dystrophin protein in the muscle fibre. The onset is usually before the third or fourth years of life. There may be a history of delay in walking. The child may fall unduly often, or has great difficulty in climbing stairs. Weakness begins in the pelvic girdle and the gait assumes a characteristic waddle so that the feet are placed too widely apart and there is an exaggerated lumbar lordosis. A quite characteristic phenomenon Gower's sign – is seen when the child, lying on his back on the floor, is asked to stand up. He will roll to one side, flex his knees and hips so that he is “on all fours” with both knees and both hands on the ground; he then extends his knees and reaches the erect posture by “climbing up his own legs”, using his hands to get higher up each leg in alternate steps. Weakness of the shoulder muscles may render the child unable to raise his hands above his head. Pseudohypertrophy of the calf muscles with wasting of thigh muscle is characteristic. Tendon reflexes become progressively diminished and finally cannot be elicited. By the age of 10 years the child is usually confined to a wheelchair. Skeletal and postural deformities particularly scoliosis may later become severe. Heart may fail from involvement of the myocardium. Mental retardation occurs in about 30% of the cases. Death is usual during adolescence from intercurrent respiratory infection, respiratory or cardiac failure.

The serum creatine kinase is greatly elevated and is often above 10,000 IU/L (normal up to 150 IU/L). Electromyography (EMG) shows myopathic changes and muscle biopsy with immunohistochemical staining for

dystrophin is confirmatory. Periodic cardiac assessment is necessary.

### *Treatment*

There is no effective treatment for this disease. Physiotherapy is important to prevent or delay contracture. Lightweight calipers and later bracing of the spine may prolong ambulation. Steroids such as deflazacort may give short-term benefit. Psychological support is needed for the child and the family. Healthy female carriers often have elevated serum levels of creatine kinase. Antenatal diagnosis is possible using DNA analysis.

### **Becker Muscular Dystrophy**

This sex-linked recessive disorder is similar but milder than Duchenne's muscular dystrophy. The progress is slower and affected boys remain ambulatory until late adolescence or early adult life.

The other less common muscular dystrophies include facioscapulohumeral muscular dystrophy, limb-girdle muscular dystrophy and dystrophia myotonica.

### **Facioscapulohumeral Muscular Dystrophy**

This form of dystrophy is transmitted as an autosomal dominant trait and can affect both sexes. The onset may be in early childhood or early adult life, most often with weakness and lack of expression in the facial muscles. In time the child cannot close his eyes, wrinkle his forehead or purse his mouth. The lips project forward due to weakness of the orbicularis oris to give the appearance of "tapir mouth". Weakness of the shoulder girdle muscles, especially the pectoralis major, serratus magnus, trapezius, spinati, deltoid, triceps and biceps results in winging of the scapulae, inability to raise the arms above the head and looseness of the shoulders. Then the pelvic girdle becomes affected, glutei, quadriceps, hamstrings and iliopsoas, so that there is lumbar lordosis and a broad-based gait. This form of muscular dystrophy usually runs a prolonged and relatively benign course well into adult life. Indeed, the face only may be affected during most of the childhood and severe crippling may be long delayed. The diagnosis can be confirmed by muscle biopsy. Elevated levels of serum creatine kinase are found only in some cases.

### *Treatment*

None is available at the present time.

### **Limb-Girdle Muscular Dystrophy**

This form of dystrophy affects mainly the muscles of hip and shoulder girdles. It is usually inherited as an autosomal

recessive characteristic. Males and females are equally affected.

This rarely appears during the first decade. Weakness first becomes obvious in the muscles of the shoulder girdle with winging of the scapulae and difficulty in raising the arms. Later the muscles of the pelvic girdle become affected. The facial muscles are never affected. The disease runs a slow course but usually leads to death before the normal age. Serum creatine kinase levels may be normal or moderately raised. Muscle biopsy reveals myopathic changes.

This type of muscular dystrophy is extremely rare in paediatric practice.

### **Dystrophia Myotonica (Myotonic Dystrophy)**

This disorder is inherited as an autosomal dominant with the locus being on the long arm of chromosome 19. Affected children nearly always have affected mothers (rather than fathers). It has been regarded as a disease of adult life, characterised by delayed muscle relaxation and atrophy (especially of the hands, masseters and sternomastoids), baldness, cataract and testicular atrophy. Clinical manifestations in childhood differ from the adult picture.

The clinical features in the neonate or older infant include hypotonia, facial diplegia and jaw weakness, delayed motor development and speech, talipes and respiratory problems. Mental retardation is relatively common. Clinical evidence of myotonia is absent (although it may be demonstrated by electromyography). Cataracts do not occur. Electromyography is the most helpful investigation. Muscle biopsy with special staining techniques and electron microscopy will confirm the diagnosis. DNA analysis will demonstrate the abnormal DM gene on chromosome 19. There is no effective treatment. If myotonia is significant, then phenytoin may be helpful.

### **MYASTHENIA GRAVIS**

This is an immune-mediated disorder of neuromuscular function caused by a reduction of available acetylcholine (Ach) receptors at the neuromuscular junction due to circulating Ach receptor-binding antibodies. It is an autoimmune disorder and patients with myasthenia gravis have higher incidence of other autoimmune diseases particularly thyroiditis.

### **Clinical Features**

Most cases are in girls and the ocular muscles are usually first affected; the child presents with ptosis or complaints of diplopia; the muscle weakness tends to be more severe as the day goes on. The pupillary reflexes are normal. The bulbar muscles are often next affected. The voice is then weak, swallowing and chewing become difficult, and there may be

asphyxial episodes due to the aspiration of upper respiratory secretions and saliva. When the facial muscles are affected a lack of expression is a striking feature. Easy fatigability of muscles is a characteristic feature but muscle atrophy and fibrillary twitchings do not occur. The deep tendon reflexes are usually present. In the worst cases the muscles of the limbs and those responsible for respiration are affected. As in the adult, the myasthenic child may run a prolonged course of remissions and relapses, but there is a tendency for the disease to reach a static phase some 5 years from the onset. There is always a risk of death from aspiration of food into the respiratory passages, from respiratory failure due to the involvement of respiratory muscles or from intercurrent respiratory infection.

Neonatal myasthenia gravis occurs in newborn infants born to myasthenic mothers and is due to the placental transfer of antibodies to acetylcholine receptors from mother to baby. The manifestations include a weak cry, generalised severe hypotonia, feeble sucking reflex and attacks of choking and cyanosis. They are temporary and disappear within a few weeks.

### Diagnosis

Myasthenia gravis should be suspected in the presence of ptosis, strabismus, bulbar palsy or severe muscular hypotonia during infancy or childhood. The diagnosis is confirmed by the immediate response to intravenous injection of edrophonium—a short-acting cholinesterase inhibitor. Atropine sulphate should be available during the edrophonium test to block acute muscarinic effects. Electromyogram demonstrates decremental response to repetitive nerve stimulation. Anti acetylcholine receptor antibodies may be measured in the plasma. Although the thymus gland is hyperplastic this is not radiologically obvious unless there is an actual thymoma, which is extremely rare in childhood.

### Treatment

This should be medical in the first instance and it consists of a cholinesterase inhibitor. The most useful drug for continuous treatment is pyridostigmine bromide given orally with a starting dosage of 1.5 mg/kg every 3–8 hours according to the clinical response. The other drug that can be given is neostigmine. Over dosage of cholinesterase's results in prolonged depolarisation of muscle end plates and muscle paralysis (cholinergic crisis). The short-acting edrophonium may be used to differentiate between cholinergic crisis and myasthenic crisis. Edrophonium injection will aggravate cholinergic crisis and transiently improve myasthenic crisis.

Apart from anticholinesterase drugs, immunosuppressive drugs (corticosteroids and azathioprine) may be used to reduce antibodies to acetylcholine receptors. Plasmapheresis

is effective in some myasthenic children as also intravenous immunoglobulin therapy. The position of thymectomy in the treatment of myasthenia gravis in childhood is not yet clear. The indications for thymectomy are inadequate control of the muscular weakness with drugs and duration of the disease of less than 2 years.

## CONGENITAL MYASTHENIC SYNDROMES

Congenital myasthenic syndromes (CMS) represent a heterogeneous group of disorders caused due to abnormalities at the neuromuscular junction. The defect may occur at the presynapse, synaptic space or post synapse. Post synaptic defects are the most common and include primary acetylcholine deficiency, rapsyn deficiency, and sodium channel myasthenia. All these disorders are autosomal recessive except for the slow channel syndrome which has autosomal dominant inheritance.

Symptoms are present from birth in most forms. All myasthenia, except transient neonatal myasthenia gravis, that begins at birth is genetic. During infancy, most have ophthalmoparesis and ptosis. Limbs weakness in mild and respiratory crises is rare.

Therapeutic agents used in CMS depend on the underlying defect and include acetylcholinesterase inhibitor, 3, 4-diaminopyridine, quinidine sulphate, fluoxetine, acetazolamide, and ephedrine.

## AUTONOMIC NERVOUS SYSTEM

### FAMILIAL DYSAUTONOMIA (RILEY-DAY SYNDROME)

This is a rare familial, autosomal recessive disorder, characterised by autonomic neuropathy and peripheral sensory neuropathy. The striking features are severe hypotonia, muscle weakness with areflexia, relative indifference to pain, excessive salivation and sweating, absent tears and recurrent pneumonia. The corneal reflex is usually absent. Difficulty in swallowing is common. There may be delayed psychomotor development and generalised seizures. Recurrent pyrexial episodes are common. In older children, attacks of cyclical vomiting with associated hypertension, excessive sweating and blotching of skin are not infrequent. Urinary frequency has also been noted in some patients.

### Treatment

No specific treatment is available. Prompt treatment of respiratory infection, adequate fluid and electrolyte therapy for cyclical vomiting, topical ocular lubricants to prevent corneal ulcer and psychiatric treatment where indicated are advocated. Most affected children die in childhood.

## BRAIN TUMOUR IN CHILDREN

Brain tumours are the second most common tumour in children. Although the aetiology of most brain tumours are unknown, certain neurocutaneous syndromes like neurofibroma and tuberous sclerosis predispose to the development of brain tumours. Infants and young children have higher risk of developing brain tumours. The common histological tumour types are—medulloblastoma/primitive neuroectodermal tumour, astrocytoma, ependymoma and craniopharyngioma.

Most brain tumours in children are malignant and are situated usually in the posterior cranial fossa. The children usually present with signs of raised intracranial pressure which can be mistaken for meningitis. Gait disturbances and ataxia are common with cerebellar tumours. Supratentorial tumours may present with focal seizures and deficits. Craniopharyngiomas occurring in the suprasellar region is minimally invasive and may present with visual disturbances and neuroendocrine deficiencies.

Diagnosis of brain tumour is confirmed by neuroimaging studies (MRI/CT scan. See Chapter 32: Figs 32.130, 131A and B, 132A to C, 134A and B, 135A and B, 136A and B and 137A to D). When brain tumour is suspected lumbar puncture should not be done as it might produce coning and sudden death. Surgery is the preferred mode of treatment. Radiation and chemotherapy have also contributed to improved prognosis.

## CEREBRAL PALSY

Cerebral Palsy (CP) is an umbrella term used for static or non-progressive disorders of the brain affecting the development of movement, posture and co-ordination resulting from a lesion of an immature brain. It is one of the common chronic neurological disorders in children. The International Workshop on definition and classification of Cerebral Palsy, held in Bethesda, in 2004 defines cerebral palsy as follows: "Cerebral palsy describes a group of developmental disorders of movement and posture, causing activity restriction or disability, that are attributed to disturbances occurring in the foetal or infant brain. The motor impairment may be accompanied by a seizure disorder and by impairment of sensation, cognition, communication and/or behaviour.

The incidence of cerebral palsy is in the region of 2.5 per 1000 live births and has always varied from one country to another. In the developing world, the incidence may be under-rated due to under-reporting and the lack of awareness. However, a significant number of children world over suffer from cerebral palsy and the issues of healthcare, educational and vocational prospects for these children are large. In

spite of improved perinatal and neonatal care, the incidence of cerebral palsy over the decades has remained the same, as more preterm babies survive with neuro-developmental morbidities.

### Aetiology

The causes of cerebral palsy can be generally classified as prenatal, perinatal and postnatal causes. However, sometimes, it is impossible to determine the precise cause of cerebral palsy in the individual patient and in 15% of the children, the aetiology is unknown. The prenatal causes include genetic factors, intrauterine infection during pregnancy, radiation, cerebral infarction, metabolic and toxic factors and hypoxia. Approximately half of all the cases of cerebral palsy are associated with preterm delivery and low birth weight. The precise nature of this relationship is not clear although hypoxia and hypotension are important factors. Although the perinatal risk factor of birth asphyxia is a well-recognised cause of cerebral palsy particularly in the term baby, the incidence of birth asphyxia among cases of cerebral palsy is declining. The main pathological lesions found in preterm infants who later develop cerebral palsy are periventricular leukomalacia and intracerebral haemorrhage. Lesions in the full term infants who develop cerebral palsy are mainly due to hypoxic ischaemic encephalopathy and are seen in thalami and basal ganglia or in the cortex and sub-cortical white matter. Postnatal causes of cerebral palsy include hypoglycaemia, hyperbilirubinaemia, meningitis, subdural haematoma, acute infantile hemiplegia and trauma.

*Classification of cerebral palsy:* Cerebral palsy may be classified in terms of physiological, topographical, aetiological and functional categories (Table 18.4).

**Table 18.4:** Classification of cerebral palsy: Cerebral palsy may be classified in terms of physiologic, topographic and functional categories

<i>Physiologic</i>	<i>Topographic</i>	<i>Functional</i>
Spastic	Diplegia	Class I – No limitation of activity
Dyskinetic	Hemiplegia	
Ataxic	Quadriplegia	Class II – Slight to moderate limitation
Hypotonic	Double hemiplegia	
Mixed	Triplegia	Class III – Moderate to severe limitation
	Monoplegia	Class IV – No useful physical activity

Adapted from Minear WL: A classification of cerebral palsy, Pediatrics. 1956;18:841



**Fig. 18.15:** Drawing from Little's monograph illustrating one of his cases of spastic diplegia (Little deformities of the human frame, 1953)

### Clinical Features

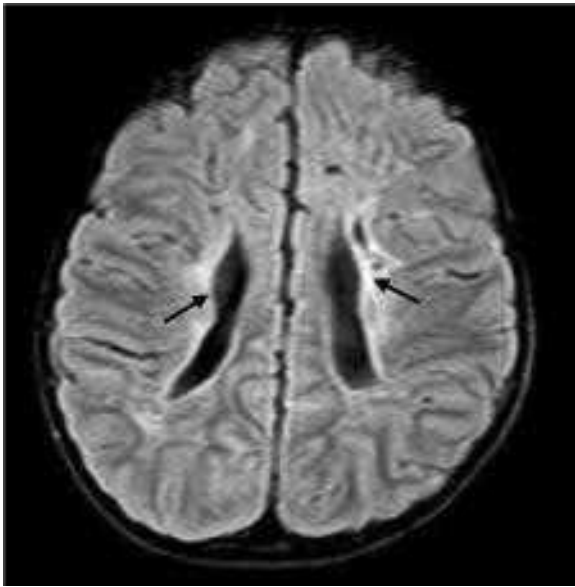
1. *Spastic Cerebral Palsy:* This group shows the features of upper motor neuron type of pyramidal tract lesion such as spastic hypertonicity, exaggerated deep tendon reflexes, ankle clonus and extensor plantar response. It may be symmetric or asymmetric and may involve one or more extremities. In spastic diplegia the lower limbs are affected more than the upper limbs. In spastic quadriplegia there is a marked involvement of all four limbs. Involvement of one side of the body is termed spastic hemiplegia.

- *Spastic diplegia:* This type of cerebral palsy, also called Little's disease, affects particularly the preterm babies (Fig. 18.15). Term babies with perinatal asphyxia are also prone. Some children go through an initial hypotonic or dystonic phase and then a spastic phase. In the first stage of hypotonia, though the child is floppy, there may be an early scissoring specially in vertical suspension. Dystonia of prematurity is a type of extensor hypertonia seen in preterm babies that emerges around 40 weeks gestation, peaks by 4 months and may last till 7 or 8 months of age. These babies often have dystonia, opisthotonus and asymmetrical neck reflex, but when turned over into prone, with neck flexed, assume a flexed posture. Dystonia of prematurity resolves spontaneously in some children, while in others, it merges into spasticity.

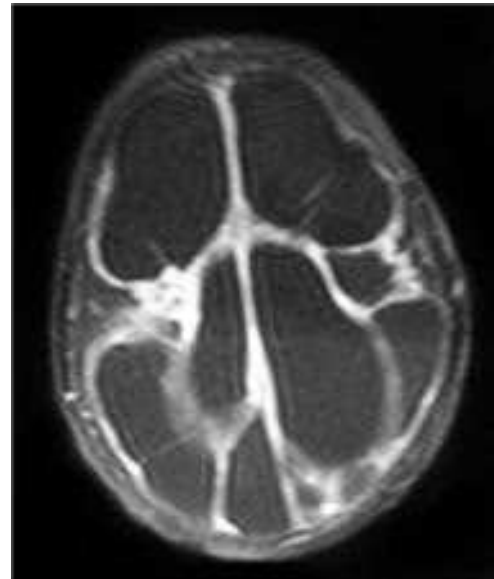


**Fig. 18.16:** Characteristic scissoring posture in a child with spastic diplegic cerebral palsy

The spastic phase of diplegia can manifest in two types. The flexor muscles are mainly affected in tonic spasticity and extensor muscles such as triceps and quadriceps in phasic spasticity. The phasically spastic muscles show brisk tendon reflexes and often the clasp-knife phenomenon. Tonically spastic muscles show decreased lengthening reaction and rapidly develop contractures. The hip flexors, hamstrings and calf muscles together with adductors of hip form the main tonic groups in the lower limbs, causing the child to be flexed at hip, knee and in equinus at the ankle with the legs usually internally rotated and the characteristic scissoring posture (Fig. 18.16). The upper limbs are flexed at elbow and wrist, and the fingers are flexed across the adducted thumb with marked spasticity of the pronators. Atrophy below the waist occurs in many patients. In spastic diplegia of low birth weight babies epilepsy is uncommon and intelligence is only moderately reduced whereas in diplegia of term asphyxiated babies, epilepsy, mental retardation, microcephaly, speech and behaviour disorders are more common. The most common neuropathologic finding in spastic diplegic cerebral palsy is periventricular leukomalacia (PVL) (Fig. 18.17), which occurs when the periventricular structures are vulnerable between 26 weeks and 36 weeks gestation, usually *in utero*.



**Fig. 18.17:** Axial T2 Flair MRI image of brain showing periventricular leukomalacia and periventricular hyperintensities (arrows) in spastic diplegic cerebral palsy



**Fig. 18.19:** Axial MRI image of brain showing multicystic encephalomalacia in spastic quadriplegic cerebral palsy



**Fig. 18.18:** Child with spastic quadriplegic cerebral palsy. Note the tracheostomy tube and the persistence of asymmetric tonic neck reflex (ATNR)

- **Spastic quadriplegia:** This is the most severe form of cerebral palsy, often as a result of intrauterine disease or malformation and in some cases due to hypoxic ischaemic encephalopathy (especially in term new borns). There is a marked motor impairment of all four extremities. Feeding is difficult because of pseudobulbar palsy with increased incidence of gastro-oesophageal reflux and aspiration syndrome

(Fig. 18.18). There is a high association with mental retardation and seizures. Speech and visual abnormalities are common. Neuropathologic findings include severe periventricular leukomalacia, multicystic encephalomalacia (Fig. 18.19) and cerebral dysgenesis. Positional deformities are common resulting in windswept posture of lower limbs, dislocation of hip, pelvic tilt, scoliosis and rib deformities.

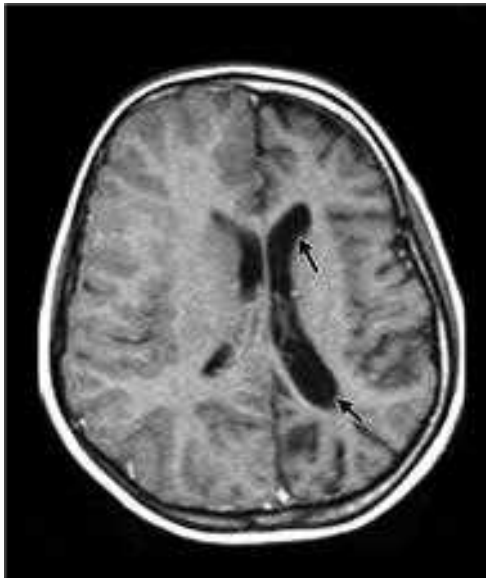
- **Spastic hemiplegia:** This type of cerebral palsy affects one side of the body. The majority are congenital and the result of maldevelopment, prenatal circulatory disturbances or perinatal stroke in the distribution of middle cerebral artery. Postnatal causes include acute CNS infection, acute infantile hemiplegia, cerebral thrombosis particularly in congenital cyanotic heart disease and subdural haematoma. The right side is more often affected than the left and the arm more severely than the leg.

Children usually present in the second half of first year with asymmetric crawling, tip toeing on the affected side while walking, asymmetric hand skills, persistence of fisting of the affected side or unusual dominance of the unaffected side. The child walks with a circumduction gait with the affected upper limb adducted at shoulder, flexed at elbow and wrist, with forearm pronated and the lower limb partially flexed and adducted at hip, the knee flexed and the foot in equinus position (Fig. 18.20). There is growth arrest of the affected extremities, particularly the





**Fig. 18.20:** Child with left hemiplegic cerebral palsy with flexed and pronated upper limb and flexed and adducted lower limb



**Fig. 18.21:** Axial T1W MRI image of brain showing atrophy of the cerebral hemisphere with prominent ventricles (arrows) in hemiplegic cerebral palsy

hands and the feet. Cortical sensory loss and haemianopia are not infrequent. Convulsions and mental retardation are seen in about one-fourth of these children. Children with right hemiplegia also have a delay in acquiring language skills and speech. Neuropathologic findings show an atrophic cerebral hemisphere (Fig. 18.21) or a porencephalic cyst.

2. **Dyskinetic Cerebral Palsy:** This type of cerebral palsy results from damage to the extrapyramidal system usually



**Fig. 18.22:** Dystonic posturing in a child with dyskinetic cerebral palsy



**Fig. 18.23:** Axial T2W MRI image of brain showing bilateral symmetrical globus pallidi T2W hyperintensities (arrows) in dyskinetic cerebral palsy

the result of neonatal jaundice or acute severe perinatal asphyxia. There is defect of posture and involuntary movement in the form of athetosis, choreoathetosis, rigidity or dystonia (Fig. 18.22). Pathologic findings include lesions in the globus pallidus (Fig. 18.23), subthalamic nucleus and status marmoratus (lesions in the basal ganglia and thalamus with a marbled appearance).

- **Athetosis:** The affected infants go through an early hypotonic phase characterised by lethargy, poor head control and feeding difficulty. This is followed after 4 months of age by the dystonic phase associated with extensor hypertonia, arching attacks, mass body

movements and abnormal persistence of primitive reflexes. The stage of involuntary movement is obvious after 2 years consisting of slow writhing distal movements. When athetosis is caused by kernicterus there is often an associated high-tone deafness. The child is dysarthric and drooling may be prominent. Seizures are uncommon and intelligence may be well preserved, but difficult to be quantified by the routine intelligence tests.

- *Choreoathetosis*: In this type the writhing athetotic movements have in addition jerky, irregular, rapid movements involving the face and proximal extremities. Stress and excitement may exacerbate the chorea.
  - *Dystonia*: This type affects the trunk and proximal muscles of the limbs and consists of abnormal twisting and sustained movements, which may be either slow or rapid. These children tend to be more severely affected.
3. *Ataxic Cerebral Palsy*  
In a small proportion of children with cerebral palsy, the clinical manifestations indicate a cerebellar defect, e.g. ataxic reeling gait, intention tremor and past pointing, dysdiadochokinesia and muscular hypotonia. Most of these cases are congenital in origin and due to malformations of the cerebellum and may have an autosomal inheritance. A few cases are due to perinatal asphyxia and hydrocephalus. Most patients have congenital hypotonia. Motor milestones and language skills are typically delayed. Truncal ataxia predominates over appendicular signs.
4. *Hypotonic Cerebral Palsy*: In a few children cerebral palsy takes the form of a hypotonic quadriplegia without any spasticity. Many infants destined to develop typical spastic diplegic or choreoathetoid cerebral palsy pass through a hypotonic phase and require continued observation for a definitive diagnosis. In benign congenital hypotonia there has usually been a normal birth and later normal development, whereas in hypotonic cerebral palsy there has often been perinatal asphyxia and is associated with learning difficulties.
5. *Mixed Cerebral Palsy*: Mixed cerebral palsy includes manifestations of two or more types usually of both spastic and extrapyramidal types. Often an ataxic component is present. These patterns of motor impairment are the result of involvement of large areas of brain affecting the cortex, subcortical areas and basal ganglia.

### Associated Disabilities

Children who suffer from cerebral palsy frequently have other disabilities, which are most significant when it comes

to everyday life. The associated co-morbid conditions result mostly from damage to other parts of the brain by the same damaging event. Approximately 50% of the cerebral palsied children have an intelligence quotient (IQ) below 70, as compared with 3% of the general population. Epileptic seizures are common in cerebral palsied children and speech defects occur in about 50%. Deafness, frequently unexpected, is common in choreoathetoid cerebral palsy particularly high-tone deafness. Squints occur in almost one-half of all affected children. Refractive errors are common. Dental problems are also common, such as gingivitis and caries due to defective chewing, tooth grinding and malocclusion. Gastro-oesophageal reflux disease and pseudo-bulbar palsy affect feeding and nutrition in these children and often results in malnutrition. Many children have emotional and behavioural problems during growing up years, particularly during adolescence.

A holistic and complete diagnosis of cerebral palsy should include in addition to the physiologic and topographic type, the functional class, all co-morbidities, neuro-radiological features or a possible neuro-anatomical level and probable etiology. The type, severity and timing of the insult and the present developmental level will also aid in planning for management.

### Early Diagnosis of Cerebral Palsy

The diagnosis of cerebral palsy (CP) depends upon a combination of motor delay, neurologic signs, persistence of primitive reflexes and abnormal postural reactions. An early diagnosis helps in early intervention preventing the secondary deformities. Infants with an abnormal obstetric or perinatal history are at increased risk to develop cerebral palsy and should be monitored closely. Clues to an early diagnosis include abnormal behaviour, psychomotor delay and abnormal oromotor or oculomotor patterns.

Neurobehavioural signs suspicious of cerebral palsy are excessive docility or irritability. A typical history includes poor feeding in the neonatal period. The baby often is irritable, sleeps poorly, vomits frequently, is difficult to handle and cuddle, and has poor visual attention.

Motor tone in the extremities may be normal or increased. Persistent or asymmetric fisting may be present. Poor head control and excessive head lag may be early motor signs. However, increased neck extensor and axial tone may make head control appear early in cerebral palsy. In many cases spasticity may not be identified until six or seven months of age. Dyskinetic patterns are not typically apparent until approximately 18 months. Ataxia may not become obvious until even later.

Primitive reflexes in cerebral palsy may be asymmetric or persistent. In normal infants, most primitive reflexes related

to posture (tonic labyrinthine, tonic neck and neck-righting and body righting reflexes) disappear when the infants are between three and six months of age. These reflexes often are not appropriately integrated or inhibited in children with cerebral palsy. Thus, delay in the disappearance or exaggeration of a primitive reflex may be an early indicator of cerebral palsy. Other abnormal signs can be elicited when the infant is held in vertical suspension. During the first few months, the appropriate response is for the baby to assume a sitting position ("sit in the air"). An abnormal response is persistent extension of the legs and crossing (scissoring), which is due to adductor spasm.

### Management

The management of children with cerebral palsy is a multidisciplinary multipronged approach and has many facets such as physiotherapy, play therapy, orthoptic care, pharmacotherapy, hearing aids, speech therapy, correction of refractive error, orthopaedic surgery, special education, etc. It is the responsibility of the paediatrician to coordinate the whole management. Parents are an integral part of the management team. The objectives of the treatment programs are to improve function, prevent deformity and to encourage independence. A good program should have ongoing assessments, plans, interventions and regular follow-up.

*Assessments:* A proper assessment of the child noting his capabilities and disabilities (motor, mental, speech, vision, hearing and psychological) is made. Depending on the initial assessments, other specialists including paediatric ophthalmologist and ENT surgeon may need to evaluate the child.

The practice parameter from the American Academy of Neurology and the Child Neurology Society recommends the following approach to the evaluation of the child with cerebral palsy. All children with cerebral palsy should undergo a detailed history and physical examination. It is particularly important to determine that the condition is static rather than progressive or degenerative. It is also important to classify the type of cerebral palsy. Screening for comorbid conditions including learning disability, visual and hearing impairments, speech and language disorders, and disorders of oro-motor functions are warranted as a part of the initial assessment. An EEG is recommended when there are features suggestive of epilepsy. Neuroimaging is recommended to both establish an aetiology and for prognostic purposes. MRI is preferred to CT scan. Metabolic and genetic testing is considered if the clinical history or findings on neuroimaging do not determine a specific structural abnormality or if there are additional atypical features in the history or clinical examination.

### Treatment

Earlier in the child's life the treatment is begun, better would be the result. An early infant stimulation programme during the first 2 years of life with emphasis on more than just improving motor deficits is emphasised.

*Parental guidance:* Parents play a central and crucial role in treatment. Parents need to be counselled about the condition, therapy options and necessity of family support.

*Physiotherapy:* Physiotherapy combined with orthotics with occasional plaster immobilisation and orthopaedic surgery remains the mainstay of treatment. The common methods of therapy are the following:

The Bobath method: This method encourages normal developmental sequences by inhibiting primitive reflexes and promoting postural reflexes.

The Peto technique: This is an individualistic program based on careful assessment of child's needs and a tailor-made educational plan.

*Pharmacotherapy:* Drugs have a limited role in cerebral palsy. Pharmacotherapy to decrease spasticity includes benzodiazepine, baclofen, botulinum toxin and dantrolene. It has been claimed that levodopa will occasionally produce dramatic results in children with athetoid cerebral palsy. Anticonvulsant drugs are indicated in epilepsy.

*Surgery:* Orthopaedic interventions are indicated to release contractures or other deformities. Selective dorsal rhizotomy has to be occasionally resorted to, to decrease spasticity. In a few older children with congenital hemiplegia complicated by frequent and uncontrollable epileptic seizures, the operation of hemispherectomy has abolished the seizures.

*Schooling:* Some cerebral palsied children of normal intelligence, especially those with hemiplegia and diplegia, may manage well in a normal school. On the other hand, the spastic or athetotic child who is severely crippled but educable is best educated in a special school (day or residential) for cerebral palsied children. The family of the cerebral palsy child needs regular counselling and the benefits of community services to cope with the stress of bringing up a child with cerebral palsy.

### Prevention of Cerebral Palsy

It would be ideal to prevent cerebral palsy, but not often achieved. All the steps in the causal pathway of cerebral palsy are not fully understood. MMR vaccinations for adolescent girls, anti-D for Rh-negative mothers and thyroid status screening for antenatal mothers can be done prior to conception. During pregnancy, regular antenatal check-ups including adequate maternal nutrition and a tertiary centre

referral for high risk pregnancies are ideal. Transfer of very preterm babies in-utero to a higher centre can be a crucial intervention in the perinatal period. Postnatally, phototherapy and other interventions for neonatal jaundice and Vitamin K at birth to prevent brain haemorrhage can decrease the neurodevelopmental morbidities at later life. In early childhood, child-safe environments at home and community can prevent some of the trauma related morbidities.

## LEARNING DISORDERS

Words used to describe individuals with learning disorders such as the terms mental deficiency, mental retardation or mental handicap are taken to mean a failure of development of the mind. This is in contrast to dementia, which means a disintegration of the fully developed mind. As a group these children have in common learning difficulty. The severely affected have difficulty learning to walk, feed, dress and communicate. The more mildly affected have difficulty in acquiring social and physical skills to enable them to earn a living and cope with the demands of the society. Words used to describe the severity of the learning difficulty, e.g. idiot, imbecile; feeble-minded, moron have become terms of abuse and even the terms mental retardation and handicap are being abandoned. The term learning disability is preferred now and can be either global or specific.

### LEARNING DISABILITY (DEVELOPMENTAL RETARDATION)

When the abilities of a child fall below the -2 standard deviation as compared with the normal population, which translates into an intelligence quotient (IQ) of less than 70, learning disability or more specific global learning disability is considered. However, caution needs to be exercised in blindly following intelligence quotient, without looking at the abilities and needs of child, as most intelligence tests assess only a few components of the multiple intelligences.

The WHO classifies this mental handicap into profound (IQ 0-20), severe (IQ 20-34), moderate (IQ 35-49) and mild (IQ 50-70). The child with an IQ between 50 and 70 is educable and may require additional educational concessions and inputs. The child with an IQ between 35 and 49 is trainable and requires special curriculum and school settings and may become functionally independent. The child with an IQ less than 35 requires regular care and is sometimes even dependent for his self care skills. Such children may require an institutionalised care later on.

### Aetiology

The vast majority of cases of learning disorder can be placed in one of two broad aetiological groups, primary amentia

which is due to inheritance or defects in the child's genetic material; and secondary in which the brain, derived from a normal germ plasma, has been damaged by environmental influences which may be operative prenatally, perinatally or postnatally. In some cases both genetic and environmental factors combine to result in brain damage. It must be stressed, however, that in individual patient, it is quite often impossible to determine the precise cause of the mental retardation. For example, in the case of a severely retarded child, apnoeic and cyanotic attacks in the first week of life could indicate brain damage resulting from anoxia or respiratory difficulties due to malfunctioning of an abnormally formed brain.

### Genetic Causes

A large number of single gene defects have been uncovered as causes of learning disorder. Many of these fall into the category of inborn errors of metabolism. They are now numerous and include phenylketonuria, maple syrup urine disease, the organic acidurias, homocystinuria, argininosuccinic aciduria, Hartnup's disease, galactosaemia, pyridoxine dependency, Niemann-Pick disease, Gaucher's disease, Tay-Sach's disease, mucopolysaccharidoses and others such as Sturge-Weber syndrome, tuberous sclerosis and neurofibromatosis. Some cases of sporadic cretinism and all cases of non-endemic familial goitrous cretinism are also due to single gene defects. Another rare example is familial dysautonomia (Riley-Day syndrome). While the single gene defects cited above are each relatively rare, it has been recognised that X-linked genes are quite frequently responsible for non-specific mental retardation. In many of the affected males a marker X-chromosome has been identified. The marker in this "fragile X syndrome" is a "fragile site" occurring at band q27 or q28 (i.e. towards the end of the long arm) of the X-chromosome. However, not all males with X-linked non-specific mental retardation have this fragile site on the X-chromosome. At least three distinct forms of X-linked mental retardation have been described which seem to breed true within families. The most clearly definable is found in males with the marker X-chromosome and macro-orchidism. The enlarged testes become obvious after puberty and are only occasionally noticeable at birth. The degree of learning difficulty is usually severe but may be mild. Specific speech delay is common and is associated with a characteristic rhythmic quality of "litany speech". Epilepsy may be a feature in some severely affected boys. In another group of families both the marker X chromosome and macro-orchidism are absent but the other clinical features are indistinguishable from those described above. In the third type of X-linked mental retardation there is no marker chromosome but the affected boys

show microcephaly, severe retardation and small testes. The female carriers of the marker X-chromosome are generally of normal intelligence although some have mild disability, possibly related to non-random X-inactivation in the central nervous system. Chromosome analysis of boys with non-specific learning disorder is essential for genetic counselling. When the characteristic clinical features described above are present in a boy with no family history the recurrence risk seems to be about 10%.

Some types of mental retardation have been clearly related to gross chromosomal abnormalities. The most severe degrees are usually produced by non-dysjunction during gametogenesis in the mother, leading to trisomy for one of the small acrocentric autosomes. In these conditions the long-recognised correlation with advancing maternal age has been explained on the assumption that the aging ovum is more prone to favour non-dysjunction. Down's syndrome is the most common of the trisomies (about 1.8 per 1000 live births) and is a major cause of profound and severe learning disorder. Only a rare case falls into the moderate category.

The next most common autosomal trisomies in live-born children are trisomy 13 (Patau's syndrome) and trisomy 18 (Edward's syndrome) with frequencies of about 0.5 and 0.1 per 1000 live births respectively. Each causes such severe and multiple abnormalities including profound learning disorders that those affected rarely survive infancy.

A variety of structural chromosome anomalies have also been found associated with severe learning disability. The best defined of these is the Cri-du-Chat syndrome, which is due to partial deletion of the short arm of chromosome 5. About two-thirds of the patients have been females and its frequency at birth is 1/50,000–1/100,000 or less. The name of this syndrome derives from the characteristic mewing-like cry, which is present from the neonatal period. The birth weight is low. Both physical and mental developments are markedly retarded. In Wolf-Hirschhorn syndrome many features similar to the cri-du-chat syndrome occur, although the cat-like cry is often absent. It is due to partial deletion of the short arm of chromosome 4.

### Rett's Syndrome

In 1966, Rett described 22 mentally handicapped children, all of them girls, who had a history of regression in development and displayed striking repetitive hand movements. It is now evident that this clinical disorder affects between 1 in 10,000 to 1 in 30,000 female infants, with signs of developmental regression appearing during the first year of life and accelerating during the second year of life.

These girls, who have normal antenatal, perinatal and postnatal periods have normal development till 6 months of age. Slowing head growth beginning 6 months of age usually

precedes the stagnation stage which moves into regression by the second year of life. The regression stage is characterised by rapid developmental deterioration, autistic features and stereotyped hand movements with loss of purposeful hand use. Rhythmic hand movements with fingers usually adducted and partly extended are characteristic with patting or lightly clapping them, banging the mouth or wringing and squeezing intertwined fingers. In some girls there are choreiform trunk and limb movements and dystonia. As they grow older the girls become more placid, their lower limbs progressively stiff with wasting, scoliosis and respiratory dysrhythmias, hyperventilation and apnoeic episodes. A defect in the methyl CpG binding protein 2 (MECP2) gene on X chromosome has been linked with most Rett syndromes.

Most of the genetically determined types of disordered mental function discussed so far have been of severe to moderate degree. On the other hand, rather more than 75% of all learning disorders fall into the mild learning disability category (IQ 50-70) and cannot be attributed to single gene or gross chromosomal abnormalities. Although, it is accepted that genetic influences play a major part in determining the child's intelligence, there is a good evidence that environmental influences also affect intelligence.

### Environmental Causes

In some cases learning disability has resulted from damage to a normally developing brain by some noxious environmental influence. They may operate at various periods in the stage of development. Microbial causes of brain damage account for about 10% of all the cases of learning disorder associated with microcephaly.

#### *Prenatal*

Rubella during the first 12 weeks of pregnancy can certainly damage the foetal brain. Toxoplasmosis may also be associated with mental retardation. Cytomegalovirus is the commonest known viral cause of mental retardation. About 40% of the women enter pregnancy without antibodies, about twice the number who are susceptible to rubella. It has been estimated that about 1% of the pregnant women in London undergo primary infection and that half of their infants are infected in utero. While most of these congenital infections are asymptomatic and only a few exhibit the severe illness, proportions are subsequently found to have learning disorders or to suffer other neurological deficits. Human immunodeficiency virus infection is a well-known cause of mental retardation. Maternal irradiation has been shown to result in mental retardation with microcephaly, and sometimes microphthalmia as in the survivors of the Hiroshima and Nagasaki atomic attacks. The effect upon a child's intelligence of adverse environmental factors during

the mother's pregnancy, such as poverty, malnutrition, excessive smoking and emotional stress are difficult to assess. They might increase the risk of learning disorder by their association with intrauterine foetal malnutrition.

### *Perinatal*

There is a well-documented association between some of the complications of pregnancy and abnormalities of the brain including mental retardation. These complications such as antepartum haemorrhage, pre-eclampsia, breech presentation and complicated or instrumental delivery are frequently associated with intrapartum foetal anoxia. It is, however, extremely difficult to assess the importance of intrapartum or neonatal anoxia as a cause of later neurological disability.

### *Postnatal*

Postnatal causes of mental retardation include meningitis, encephalitis, hypoglycaemia, bilirubin encephalopathy, subdural haematoma, hypernatraemia and head injury. Lead encephalopathy is a rare but undoubted cause of permanent brain damage. It remains uncertain whether low-level lead exposures; with blood levels below 1.9  $\mu\text{mol/l}$  (40  $\mu\text{g}/100\text{ ml}$ ) may cause some cognitive impairment and possibly behavioural abnormalities.

## **Diagnosis**

In most cases the diagnosis of disordered learning ability can be made in the first year of life, provided the physician is familiar with the stages of development in the normal baby and that he realises the variations, which may occur in perfectly normal babies. It is essential that a thoughtful history be obtained from the parents, to be followed by a detailed physical examination of the child. Frequently the child must be seen on several occasions before a final conclusion is possible. There may be factors which indicate that the child is "at risk" and more likely to be retarded than others. These include prematurity, complications of pregnancy or labour, a history of asphyxia neonatorum, intra or periventricular haemorrhage, jaundice in the newborn period, convulsions or cyanotic attacks, maternal rubella or a family history of learning disorder. The basis of the diagnosis of learning disorder may be conveniently discussed under four headings.

### *Physical Abnormalities*

Certain physical features are undoubted evidence of associated mental defect. These include the characteristic signs of Down syndrome, microcephaly, cretinism and gargoylism. Other physical abnormalities are often, although not invariably, associated with learning disorder. In this

group are cerebral palsy, the bilateral macular chorioretinitis of toxoplasmosis, Turner syndrome and hydrocephalus. Certain other physical "stigmata" are seen more commonly in learning disordered than in normal people, but in themselves they can do no more than direct the physician's attention towards a more careful assessment of the child's intellectual development. Such peculiarities are a high narrow (saddle-shaped) palate, abnormally simple ears, hypertelorism, marked epicanthic folds and short, curved fifth finger. A distinctive pattern of altered growth and morphogenesis can be recognised in the children of mothers who consume large quantities of alcohol during pregnancy. They exhibit both pre- and postnatal growth failure involving weight, length and head circumference. Neurological abnormalities include hypotonia, irritability and jitteriness, poor co-ordination, hyperkinesis, and learning difficulties, which may vary from severe to mild. Dysmorphic features include short palpebral fissures (canthus to canthus), epicanthic folds, and hypoplastic or absent philtrum, thin upper lip, broad nasal bridge with upturned nose and mid-facial hypoplasia. Other congenital anomalies may involve the heart, genitourinary system, eyes, ears, mouth or skeleton. Haemangiomas and herniae are not uncommon. Abnormal palmar creases and hirsutism have also been recorded.

### *Delayed Psychomotor Development*

It is characteristic of the learning disordered child that his development is delayed in all its parameters. He is slow in showing an interest in his surroundings, slow in attempting to handle or play with objects, slow to sit or stand unsupported or to walk on his own, late in speaking, late in acquiring bladder or bowel control. A lack of concentration or sustained interest is also obvious. Thus, after handling a new toy or object for a minute or two he loses interest and throws it down. His lack of interest in things around him may raise the suspicion of defective vision, just as his lack of response to sounds is apt to lead to a mistaken impression of deafness. Infantile practices tend to persist beyond the normal period, e.g. putting objects into his mouth, excessive and prolonged posturing of his hands and fingers before his eyes, drooling and slobbering. The physician must obviously be familiar with the various developmental stages of normal infants and children before he is in a position to make a judicious assessment of an individual patient. A brief outline of the more positive developmental steps is shown in Table 18.5. The best assessment is to be expected from the doctor who has had long and intimate contact with normal children in the child health clinic or in their family practice, provided that during their undergraduate period they have developed the capacity to observe, and to appreciate the significance of their observations.

**Table 18.5:** Developmental steps in the normal child

Age	Development
4 weeks	Head flops back when lifted from supine to sitting position Sits with rounded back while supported Primitive grasp reflex elicited by placing object in palm Responds to sudden noise
8 weeks	Minimal head lag when pulled into sitting position Sits with almost straight back and head only nods occasionally Primitive grasp reflex slight or absent Smiles readily: Vocalizes when talked to
12 weeks	Horizontally tracks objects with head and eyes No head lag when pulled into sitting position Sits supported with straight back: Head almost steady No grasp reflex: Holds objects in hand for short time Watches own hand movements Turns head towards sounds
6 months	Lifts head from pillow Sits unsupported when placed in position Rolls from supine to prone position Grasps objects when offered Transfers objects from one hand to the other Responds to name Held standing, can bear weight on legs and bounces up and down No more hand regard: Finds feet interesting
12 months	Understands simple sentences and commands Can rise to sitting from supine position Pulls to standing position by holding onto cot side Walks holding hand or furniture Speaks a few recognisable words Points to objects which are desired Throws objects out of pram in play
15 months	Walks unsteadily with feet wide apart; falls at corners Can get into standing position alone Tries untidily to feed himself with spoon Plays with cubes: Places one on top of another Indicates wet pants Now seldom puts toys in mouth Shows curiosity and requires protection from dangers

18 months	Can walk upstairs holding onto hand or rail Can carry or pull toy when walking Can throw ball without falling Points to three or four parts of body on request Indicates need for toilet Lifts and controls drinking cup Points to three to five objects or animals in picture book Runs safely on whole foot: Can avoid obstacles Can kick a ball without losing balance Can walk upstairs: Holding rail coming downstairs Turns door handles Demands constant adult attention
3 years	Walks upstairs with alternating feet Washes and dries hands with supervision Rides tricycle Draws a man on request – head, trunk and one or two other parts Can count up to ten Discusses a picture Listens to and demands stories Likes to help mother in house, father in garden Eats with fork and spoon Can dress and undress Asks incessant questions Climbs ladders and trees
4 years	Engages in role play, e.g. doctor or nurse Uses proper sentences to describe recent experiences Can give name, age and address Draws man with features and extremities Matches four primary colours correctly Plays with other children Alternately cooperative and aggressive with adults or other children
5 years	Runs quickly on toes: Skips on alternate feet Can tie shoelaces Can name common coins Draws recognisable complete man Names four primary colours; matches 10-12 colours Cooperates more with friends: Accepts rules in games Protective towards younger children and pets May know letters of alphabet and read simple words

**Abnormal Behaviour and Gestures**

Learning disordered children frequently engage in types of behaviour and mannerisms, which are obviously abnormal for their age. Thus, in early infancy the retarded baby may

be excessively “good” in that he will lie in his bed for long periods without crying or showing restlessness, interest in surroundings, or boredom. In other cases there is constant or prolonged and apparently purposeless crying. Teeth grinding

when awake is a common and distressing habit of many with profound learning disorders. The older child may exhaust his mother by his aimless overactivity, which may at times endanger his life. Certain rhythmic movements, although by no means confined to learning disordered children, are more commonly present in them and for more prolonged time periods. These include head banging, body-rocking to-and-fro, and head rolling. Profoundly disordered children frequently lack the normal capacity for affection, they may be prone to sudden rages, and they may assault other younger children.

### *Convulsions*

Most epileptics are of normal intelligence. None the less, epileptic seizures occur more frequently among mentally retarded children than those who are normal. Frequently repeated generalised seizures lead to slowly progressive intellectual deterioration. The association of infantile spasms (hypsarrhythmia) with severe learning difficulties has been described previously.

### **Differential Diagnosis**

The diagnosis of learning disorder is obviously one in which the physician must not be wrong or he will cause the parents unjustifiable and unnecessary grief and anxiety. Some infants have a "slow start" but catch up later, and in the absence of manifested physical signs, such as microcephaly or Down's syndrome, a firm diagnosis of learning disorder should only be made after a period of observation during which the rate of development is assessed. There are now available developmental screening protocols in which a child's development can be charted in a longitudinal fashion, making it easier for the less experienced doctor to detect early departures from the normal. It is easy to confuse learning disorder with cerebral palsy. Indeed the two frequently coexist. Careful neurological examination, repeated on several occasions, will reveal the motor handicaps of cerebral palsy. The deaf child has frequently been diagnosed as mentally retarded, sometimes with tragic results. This mistake should not occur when the physician takes a detailed history and follows it with a careful physical examination. The deaf child will, of course, show a lively visual interest and his motor skills will develop normally. A difficult if not very common problem is the child who fails to develop speech (developmental dysphasia). He is readily confused with the learning disordered child although here too a careful history and period of observation will reveal that in other respects his psychomotor development is proceeding normally. Particular caution is required in the intellectual assessment of the child who has been emotionally deprived

by the break-up of his home, death of his mother, or who has been otherwise bereft of normal security. The child may require a long period outside an institution in a comforting and reassuring environment, before he can be assessed.

Until recently many autistic children were wrongly labelled mentally defective. Autistic children have a varied profile ranging from superior intelligence to severe learning disability. The most characteristic features of infantile autism are a complete lack of interest in personal relationships which contrasts with an interest in inanimate objects; frequently a preoccupation with parts of the body; a tendency to react violently and unhappily to changes in environment; loss of speech or failure to acquire it, or the meaningless use of words or phrases and grossly abnormal mannerisms such as rocking, spinning or immobility (catatonia). The most outstanding feature of the autistic child is the way he rejects social contacts. None the less, although he is aloof, does not respond to a greeting with a smile, does not wave goodbye and so forth, he is yet aware of social contact. Thus, he may engage furiously in one of his more irritating mannerisms when someone enters his presence and ceases whenever he is left alone. There is an odd high incidence of professional and educated people among the parents of autistic children. Such children, of course, are wrongly placed in institutions for profound and severe learning disorders. Some have responded considerably to psychotherapy as outpatients or inpatients in departments of child psychiatry.

### **Intelligence Tests**

Psychological testing and evaluations are of considerable although limited value in providing an estimate of a child's probable potential ability. They cannot, naturally, take into account the influence of such variables as zeal, ambition, interest, encouragement or the lack of it, good or bad teaching so forth. There are many aspects of intelligence and personality and the various tests assess these in different degrees. It is not proposed here to describe these tests in detail; they are reliable only in the hands of the expert. The most commonly used are: the Gesell tests for infants and the modifications of Cattell and Griffiths; for older children the Stanford-Binet scale and the revised test of Terman and Merrill, also the Wechsler Intelligence Scale for Children; for adolescents and adults the Wechsler Adult Intelligence Scale and Raven's Progressive Matrices. There are also several useful personality tests of which the best for the mentally retarded are the Rorschach test and the Good enough "Draw-a-Man" test. In the case of the school child it is also important to enquire about educational progress. An evaluation of the results of various tests competently performed is of great value in planning suitable education or training for the mentally handicapped child.



Investigations: Depending on the history and physical examination the following investigations may be done. Thyroid function test, metabolic screening for inborn error of metabolism, cranial CT or MRI scan, EEG, karyotyping including examination for fragile-X syndrome, TORCH infection screen, etc.

### Specific Learning Disability

Specific Learning Disability (SLD) is a disorder in one or more of the basic psychological processes involved in understanding or using language, spoken or written and is not the result of visual, hearing or motor handicaps or mental retardation. There is a discrepancy between aptitude, measured by intelligence tests and achievement, as reflected in academic performance. The specific learning disability can be of reading (dyslexia), writing (dysgraphia) or mathematics (dyscalculia). Some children may have associated behavioural problems like attention deficit hyperactivity disorder. The children with SLD require bypass strategies and concessions based on the primary deficit. They learn to adapt well and most have a remarkable ability to learn, when provided proper strategies.

### Prevention of Learning Disorders

The prevention of neurological disorder has become increasingly possible in recent years. Indeed, the more efficient application of knowledge, which has been available to us for some years, would considerably reduce the present incidence of brain damage from such disturbances as perinatal hypoxia, hypoglycaemia, kernicterus and hypernatraemia and the prevalence of maternal rubella by the institution of anti-rubella vaccination. Screening programmes during the neonatal period for several of the treatable inborn errors of metabolism such as phenylketonuria, homocystinuria, maple syrup urine disease, galactosaemia as well as congenital hypothyroidism are making some impact upon the number of learning impaired children.

A most common development in the field of prevention is to be found in prenatal diagnosis. This is most often based upon examination of the amniotic fluid obtained by transabdominal amniocentesis between the 14th week and 16th week of pregnancy and supported by ultrasonography. Sampling of chorionic villi or foetal blood or tissue may also be employed in selected cases. Chromosome analysis of amniotic cell cultures may reveal abnormalities such as trisomies 21, 13 and 18, or trisomy affecting the sex chromosomes (XXX and XXY). It may, on the other hand, lead to a diagnosis of 21/14 translocation in the foetus when one of the parents is known to be a translocation carrier and other more complex translocations have also been demonstrated. The sex of the

foetus can also be determined when there is a known sex-linked inherited disease in a family, and where the risk to male progeny is 50:50. While most of the X-linked disorders are not associated with learning disorder (e.g. haemophilia) a few, such as Hunter's syndrome do lead to progressive mental deficiency.

Recent years have seen a rapid increase in the number of inborn errors of metabolism, which are capable of prenatal diagnosis. A considerable number of these are associated with progressive neurological deterioration. Most are autosomal recessives although a few are X-linked. The laboratory techniques involved include enzyme assays on cultured amniotic fluid cells, measurement of metabolites, and biochemical analysis of the liquor.

Analysis of foetal blood obtained at fetoscopy has also been applied in the prenatal diagnosis of the haemoglobinopathies. Molecular genetic techniques allow earlier diagnosis and intervention.

When severe and irreversible disorders of the foetus are recognised prenatally therapeutic abortion may be considered. This is a complex problem with ethical, legal and religious implications. Occasionally, prenatal testing will reveal a treatable disease, as when congenital adrenal hyperplasia due to 21-hydroxylase deficiency is confirmed by a high level of 17-hydroxyprogesterone in the amniotic fluid, when no delay should arise in instituting appropriate treatment from the time of the infant's birth. In practice it has been found that in the majority of cases involving prenatal diagnosis the extreme parental anxiety, which is common in this situation, is relieved because in most instances the foetus is found not to be carrying the chromosomal or enzyme abnormality.

Prenatal diagnosis demands careful selection of patients as the techniques are not entirely devoid of risk and there can be no absolute guarantee of success. Not only must there be full discussion and investigation of the family problems, but there must also be close liaison between the clinicians, geneticists and the laboratories. This should preferably be undertaken before and not after the female partner has become pregnant. Suitable indications for prenatal diagnosis include:

- Advancing maternal age, where the risk of chromosome abnormalities, particularly trisomy, is increased
- When either parent is a translocation carrier or has chromosomal mosaicism with a high risk of an abnormal foetus
- When there has previously been a child with a chromosomal abnormality such as Down's syndrome
- In families with X-linked and certain autosomal recessive diseases.

## MANAGEMENT OF CHILDREN WITH LEARNING IMPAIRMENT

The concept of management rather than treatment is central to the care of the learning disordered child. Treatment involves measures aimed at curing or improving a disorder or disability. Management is the continuing totality of all treatments of all the patient's dimensions—somatic, intellectual, emotional and social.

It must first be stated that with the exception of cretinism, phenylketonuria, galactosaemia, and a few other rare inborn errors of metabolism there is at the present time no specific treatment for the learning disordered. The only drugs of value are anticonvulsants for children who also have epileptic seizures, and medications for children with attention deficit hyperactivity disorder.

Secondly, once the physician has reached a definite diagnosis of developmental delay in a child, but not before, he must impart this information to the parents. This task requires time, tact, abundant sympathy and understanding, but it must be discharged in simple unambiguous phrases. In the case of the very young child, the doctor would be wise not to commit himself too firmly or too soon to an assessment of degree or to a forecast as to educability. These matters can be resolved with time, and it is the physician's duty to see the child and his parents regularly, and to be prepared to give of his time to answer their many questions. In particular, the irrational feeling of guilt, which many parents have on hearing that their child has a significant learning disorder, must be assuaged by quiet discussion and explanation. Some parents will refuse to accept the situation at first. They may "go the rounds" of the specialists seeking a happier diagnosis. This is completely understandable. At the end of the day they will still require and merit all the help, which their personal physician can offer. This is often particularly necessary when the child is at home with normal brothers and sisters where many different stresses and strains can arise. Genetic counselling will frequently be indicated, and the physician should also consider discussing contraception with the parents. They may well need guidance as to where these services can be obtained. Many professionals including teachers, therapists, social workers, and psychologists are involved in the management of these children.

Integration in regular schools is frequently an appropriate option. Otherwise the child is educated at a special school

(day or boarding). His progress there will depend not only upon his innate ability but also on the support and training he receives, and has earlier received, from his parents. The child, who proves unable to benefit from formal education at a special school, can be placed in an occupation or training centre. Here he is taught social behaviour and simple manual skills. It is undesirable that a mentally retarded child should be sent to an ordinary school if he is intellectually quite unable to benefit from such education. Suitable placement at the beginning will frequently avoid the behaviour problems and frustrations from which the disabled child must suffer if he is kept for long in an ordinary school competing with children of normal intelligence. The ability of a child to benefit from education at a special school or his suitability only for a training centre is not solely dependent on his IQ. Some children who do well at special schools have lower IQs than others who have to be transferred to training centres. Important factors are the child's personality and behaviour patterns, his home environment, and his willingness to learn. In preparation for school or training centre it is an advantage if the disabled child can be admitted to a suitable day nursery from the age of 2–3 years. This helps him to make social contact with other children while also relieving the mother of some of her load.

Children with profound learning disorder may require placement in long-term residential units specially adapted to their needs. As a general rule, the earlier this category of child is placed, the better, because a prolonged stay at home may cause the parents to neglect their normal children or the parents of a first-born learning disordered child to deny themselves further children. However, each case must be assessed on its merits with due regard for the parents' wishes, the home and financial circumstances, the ages and reactions of the other children in the family, and the behaviour and general condition of the child. The Down syndrome child is more often kept at home, because he is happy and good-natured. The child with aggressive or destructive tendencies is likely to be placed in an institution at an earlier age. Some disabled children find their way into institutions because they break the law and prove to be out of control, although they may be less severely disabled than other children who remain happily at home. The paediatrician often has to play an advocacy role for the learning of impaired child and family.

# Accidental Poisoning in Childhood

## INTRODUCTION

In spite of the many educational programmes aimed at prevention and exposure to a poison, it remains the most common childhood accident. Paediatric poisonings involve three distinct groups. Poisoning in children is quite different from that in adults. Children have their special physiology and react differently to medicament as well as to poisoning. Most childhood poisoning is accidental. Other causes include intentional overdose, drug abuse, iatrogenic and deliberate poisoning. The drugs most commonly involved in childhood poisoning are paracetamol, ibuprofen, orally ingested creams, aspirin, iron preparations, cough medicines and the contraceptive pill.

The first group involves children between the ages of 1 and 4 years. Certain children with strong oral tendencies can be identified as especially likely to poison themselves by ingesting tablets or liquids, particularly if these have a pleasing colour or are held in an attractively labelled bottle or container. Poisoning can also occur by absorption through the skin and infiltration of the eyes, i.e. ocular instillation. Patterns of accidental poisoning have been changing in recent years and while the number of children poisoned remains high, the incidence has shown a fall. There has also been a steady decline in the number of childhood deaths from poisonings. This is related to a number of factors including changes in prescribing practices, educational programmes directed towards prevention, safer packaging of dangerous drugs and safe storage of household products. Child-resistant containers have been particularly effective in reducing the incidence of death from the ingestion of prescription drugs by children. In a recent survey the rank order of poisons, drugs and chemicals, which have most often led to hospital admission, were: petroleum distillates; antihistamines; benzodiazepines; bleach and detergents and aspirin. However, when the ratios of fatalities to ingestion were analysed to give an index of the practical danger of the substances to which children

are exposed, the rank order became cardiotoxic drugs, tricyclic antidepressants, sympathomimetic drugs, caustic soda and aspirin. While noxious plants such as laburnum, foxglove and deadly nightshade continue to be ingested, a fatal outcome is exceedingly rare. Ingestions of petroleum distillates, insecticides such as chlorinated hydrocarbons and organic phosphates, and weed killers, particularly paraquat, are commoner in rural areas. Lead poisoning is in a different category as it usually involves ingestion over a fairly prolonged period.

The second distinct population involved in paediatric poisoning is the young 12–17 years old adolescent who ingests medications in a suicide attempt or gesture. They may require full psychiatric and social assessment. Also on the increase is “glue sniffing”, i.e. inhalation of various solvent vapours and ingestion of “ecstasy” and alcohol used by teenagers as recreational drugs.

The third group is the result of parents deliberately giving drugs to their children as a manifestation of Munchausen syndrome by Proxy. The most common poison given by parents is table salt, anticonvulsants and opiates. In certain situations identifying poisoning can be difficult even when the doctor is alert to the possibility.

This chapter proposes to describe the general therapeutic measures applicable to acute poisoning and then to consider some of the more common individual poisonings. The possibility of poisoning should always be entertained in acute illness of sudden onset if no cause is immediately discoverable, particularly if it is associated with vomiting and diarrhoea or if there are marked disturbances of consciousness or behaviour.

## ASSESSMENT OF THE CHILD AND MANAGEMENT

The primary assessment of the child with acute poisoning is essential for management. This should be done under the following acronym: “*ABCDE*”.

## Assessment of Airway

If at first it is found that the child can speak or cry, this means that the airway is patent and breathing is taking place and the circulation is satisfactory. Otherwise, due to the effects of poisoning there could be loss of consciousness and this would lead to a complete or partial closure of airway. However, if the airway is not patent it should be made patent and intubation may be needed.

## Assessment of Breathing

The child's respiratory rate should be checked. Tissue oxygen saturation must also be measured by pulse oximeter and arterial blood gas estimation should be done. There are a number of ingested substances such as opiates, which can induce respiratory depression. In such cases, oxygen should be given if there is respiratory depression, cyanosis or shock. However, if the child is breathing inadequately, support should be given by bag-valve mask with oxygen or by intermittent positive pressure ventilation in an intubated patient.

### Ventilatory Support

Ventilatory support is indicated if:

- Respiratory rate is less than 10/minute
- There is poor air entry despite airway being fully open
- There is arterial blood gas measurements showing falling  $PO_2$  and rising  $PCO_2$ .

### Assessment of Conscious Level

A rapid assessment of conscious level should be made by assigning AVPU method (alert, responds to voice, responds to pain, unresponsive) (Box 19.1). A detailed assessment can be made by using the Glasgow Coma Scale and Children's Coma Scale (Box 19.2).

#### Box 19.1: AVPU assessment

A = Awake or alert

V = Responds to verbal stimuli (voice)

P = Responds only to pain

U = Unresponsive to all stimuli—sternal pressure, supraorbital ridge pressure or pulling hair

Children in categories P and U will require careful assessment of their airways and ventilation. Intubation should be considered before carrying out gastric lavage or instilling activated charcoal in categories P and U.

## Assessment of Circulation

It is important to assess the adequacy of the child's circulation by the following:

- Heart rate, rhythm and pulse volume
- Blood pressure
- Peripheral perfusion: Signs of poor end organ perfusion (shock) are:

- Poor peripheral pulses
- Capillary refill longer than 2 seconds
- Blood pressure may be normal in compensated shock
- Low blood pressure indicates decompensated shock

#### Box 19.2: Glasgow Coma Scale and Children's Coma Scale

Glasgow Coma Scale (4–15 years)		Children's Glasgow Coma Scale (< 4 years)	
Response	Score	Response	Score
<b>Eye opening</b>		<b>Eye opening</b>	
Spontaneously	4	Spontaneously	4
To verbal stimuli	3	To verbal stimuli	3
To pain	2	To pain	2
No response to pain	1	No response to pain	1
<b>Best motor response</b>		<b>Best motor response</b>	
Obeys verbal command	6	Spontaneous, obeys verbal command	6
Localises pain	5	Localises to pain or withdraws to touch	5
Withdraws from pain	4	Withdraws from pain	4
Abnormal flexion to pain (decorticate)	3	Abnormal flexion to pain (decorticate)	3
Abnormal extension to pain (decerebrate)	2	Abnormal extension to pain (decerebrate)	2
No response to pain	1	No response to pain	1
<b>Best verbal response</b>		<b>Best verbal response</b>	
Oriented and converses	5	Alert, babbles, coos words to usual ability	5
Disoriented and converses	4	Less than usual words, spontaneous irritable cry	4
Inappropriate words	3	Cries only to pain	3
Incomprehensible sounds	2	Moans to pain	2
No response to pain	1	No response to pain	1

**Normal Aggregate Score = 15**

## Disability: Assessment of Neurological Function

It is assessed by assessing the level of consciousness, posture, pupillary size and reaction to light.

## Exposure

Exposure is essential for external evidence of drug abuse and drug induced rashes (e.g. purpura, swelling of lips or tongue, urticaria, angio-oedema). Record child's core and toe temperatures, because a number of drugs can cause hypo- or hyperthermia.

### Key Learning Points

#### Base line monitoring in a child with poisoning

- ECG
- Pulse oximetry
- Core temperature
- Blood glucose level
- U and E's and LFT's
- Blood gases.

## POISON IDENTIFICATION AND ASSESSMENT OF THE SEVERITY OF OVERDOSE

Subsequent to the primary assessment of the child, it is important to evaluate the severity of the overdose. To assess this properly, obtain the identity of the substance ingested, the amount taken and the length of time the child has been in contact with poison. Sometimes, it may not be easy to gather this vital information.

However, some clues about the substance taken may be obvious from the clinical signs noted during full clinical examination. An essential part of substance identification is to match the collection of signs and associated toxic effects and the offending substance as shown in Table 19.1.

### Key Learning Point

#### Amount of poison ingested

- Some idea of the maximum amount of substance that could have been ingested can be obtained from counting the number of remaining tablets or volume of liquid left in the bottle and details on packaging.

### Key Learning Points

- *Poison identification*: Routine toxicology screen on urine sample.
- *Substances identifiable*: Benzodiazepines; cocaine metabolites; methadone; opiates and amphetamines.

**Table 19.1:** Drugs and associated toxic effects

Associated signs	Possible toxin
Tachypnoea	Salicylates, CO, theophylline
Bradypnoea	Opiates, barbiturates, sedatives
Convulsions	Phenothiazines, aminophylline, salicylates, tricyclic antidepressants, insecticides, organophosphate
Hyperpyrexia	Salicylates, aminophylline, amphetamine, cocaine
Hypothermia	Aminophylline, barbiturates, phenothiazines
Hypertension	Aminophylline, amphetamines, cocaine
Hypotension	Tricyclic antidepressants, aminophylline, barbiturates, benzodiazepines, opiates, iron, phenytoin
Large pupils	Atropine, cannabis, carbamazepine, tricyclic antidepressants
Small pupils	Opiates, phenothiazines, organophosphate, insecticide
Tachycardia	Aminophylline, antidepressants, amphetamine, cocaine
Bradycardia	Tricyclic antidepressants, digoxin
Metabolic acidosis	Salicylates, ethanol, CO

## Treatment

Most children will be asymptomatic because they have taken only a minute non-lethal overdose or have ingested a substance which is harmless. Therefore, a short period of observation in a short-stay ward or in an emergency department is often all that is needed. It is better to be safe than sorry.

On the contrary, those children who have taken a potentially lethal dose of a drug or the exact nature of the substance is unknown, then measures to minimise blood concentration of the drug should be implemented. There is an urgent need to remove the poison or to inactivate or neutralise it before it reaches the circulation. Now there is no place for the use of emetics. The routine use of gastric lavage or activated charcoal is inappropriate.

### Emesis

This was the routine approach for decades. There is no evidence from clinical studies that ipecac improves the outcome of poisoned patients and thus its routine use should be abandoned.

### Gastric Lavage

Gastric lavage should not be carried out routinely in the treatment of poisoned patients. Gastric lavage should not be considered unless a child has ingested a potentially life-

threatening amount of a poison and the procedure can be undertaken within 60 minutes of ingestion. The lavage fluid can be water or isotonic saline. After lavage, the lavage tube can be used for administering the specific antidote or activated charcoal. For those children who cannot protect their airway, intubation under general anaesthesia will be necessary. Fluid from the stomach should be collected for analysis, if necessary.

### Key Learning Point

#### Gastric lavage

⇒ Gastric lavage is contraindicated if a corrosive substance, e.g. acid or alkali or volatile hydrocarbon, such as kerosene, lamp oil, lighter fluid, turpentine, paint thinners, furniture polishes, and cleansing agents have been ingested.

### Medicinal Charcoal

Activated charcoal is capable of binding a number of poisonous substances without being systemically absorbed (Box 19.3). However, there are substances which it will not absorb (Box 19.4). The effectiveness of activated charcoal decreases with time, the greatest benefit is within 1 hour of ingestion. Multidoses of activated charcoal to remove toxins undergoing enterohepatic circulation are one of the simplest, active elimination techniques. The charcoal can be given via a nasogastric tube or lavage tube. The dose of activated charcoal is 1 g/kg and repeated every 2–4 hours for the first 24 hours. The complications from charcoal are negligible.

#### Box 19.3: List of poisons for which activated charcoal is effective

Acetaminophen	Nicotine	Barbiturates
Amphetamine	Paraquat	Phenothiazines
Atropine	Phenols	Benzodiazepines
Quinine	Camphor	Salicylates
Digitalis derivatives	Strychnine	Sulphonamides
Indomethacin	Theophylline	Tricyclic antidepressants
N-acetylcysteine		

#### Box 19.4: Substances not bound to charcoal

Boric acid	Lithium
Cyanide	Malathion
Ethanol	Methanol
Ethylene glycol	Petroleum distillates
Iron	Strong acids and alkalis

### Key Learning Point

#### Laxatives

⇒ The use of laxatives alone has no role in the management of the poisoned child and is not a recommended method of gut decontamination. The routine use of a laxative plus activated charcoal has mostly been abandoned.

### Other Elimination Measures

- Urinary alkalisation can be used to expedite the excretion of acidic drugs, e.g. salicylate, isoniazid and phenobarbitone
- Haemoperfusion, haemofiltration and dialysis are effective in certain poisonings (Box 19.5).

**Box 19.5:** Dialysis, haemoperfusion and haemofiltration are effective in the following poisonings

- Dialysis: Salicylate, methanol, ethylene glycol, vancomycin, isopropanol
- Haemoperfusion: Carbamazepine, barbiturates, theophylline
- Haemofiltration: Aminoglycoside, theophylline, iron, lithium

### Whole Bowel Irrigation

Whole bowel irrigation (WBI) should not be used routinely in the management of the poisoned patient. However, it can be used to physically eliminate highly toxic substances especially those not absorbed by activated charcoal and have a long gastrointestinal transit time, e.g. iron, sustained release or enteric-coated preparations. This is done by giving orally a large quantity of osmotically balanced polyethylene glycol electrolyte solution.

### Antidotes

A wide range of antidotes exists as shown in Table 19.2.

**Table 19.2:** Poisons with antidotes

Indication	Antidote
Beta-blockers	Glucagon
Benzodiazepines	Flumazenil
Carbon monoxide	Oxygen
Chloroquine	Diazepam in high doses
Digoxin	Digoxin specific antibodies
Hypoglycaemic agents	Glucose
Iron salts	Desferrioxamine
Isoniazid	Vitamin B <sub>6</sub>
Lead	Calcium EDTA, BAL
Methanol	Ethanol
Methaemoglobin producing agents	Methylene blue
Morphine derivatives (opiates)	Naloxone
Organophosphates	Atropine
Paracetamol	N-acetylcysteine
Ethylene glycol and methanol	Fomepizole (Antizol)

### Convulsions

Single short-lived convulsions do not require treatment. If convulsions recur frequently, lorazepam 100 µg/kg (maximum 4 mg) or diazepam (preferably as emulsion) 300–400 µg/kg

(maximum 20 mg) should be given by slow intravenous injection into a large vein. Benzodiazepines should not be given by the intramuscular route for convulsions. If the intravenous route is not readily available, diazepam can be administered as a rectal solution. Midazolam can be given by the buccal route.

## SALICYLATE POISONING

Accidental poisoning in children due to salicylate has recently declined in incidence following the packaging of salicylates in child resistant containers and also because aspirin is being superseded by paracetamol and ibuprofen as the standard domestic analgesic. Salicylate is usually ingested in the form of aspirin (acetylsalicylate). This is often accidental but sometimes it has been given with therapeutic intent by the parents and even by the doctor. On occasion, oil of wintergreen (methylsalicylate) a source of the salicylate, has been swallowed, one teaspoonful of which contains the equivalent of 4 gm aspirin. Salicylate poisoning can also occur due to local application of ointments containing salicylic acid.

Prognosis in the individual case is determined much more by the interval of time, which has elapsed between the ingestion of the poison and the start of treatment than, by the level of the serum salicylate. Indeed, the toddler can show signs of severe poisoning with a salicylate level as low as 2.9 mmol/L (40 mg/100 ml). With the exception of rheumatic fever, juvenile idiopathic arthritis (JIA) and Kawasaki disease, aspirin should not be prescribed for infants or children.

### Clinical Features

Rapid, deep, regular, acyanotic breathing or air hunger is almost diagnostic of salicylate poisoning. Cases may be misdiagnosed as “pneumonia” but the hyperpnoea of salicylate poisoning is quite different from the short, grunting respirations of pneumonia. Other early manifestations of salicylate poisoning such as nausea and vomiting are difficult to evaluate in infants and toddlers and they cannot often describe tinnitus.

The hyperpnoea has a double aetiology. It is initially due to direct stimulation by salicylate of the respiratory centre of the brain. The resultant overbreathing washes out CO<sub>2</sub> from the lungs and causes a respiratory alkalosis with a blood pH (> 7.42) and lowered PCO<sub>2</sub> (< 33 mmHg). This alkalotic phase is commonly seen in adults with salicylate poisoning, but in young children, an accelerated fatty-acid catabolism with excess production of ketones results in the early establishment of a metabolic acidosis. By the time the poisoned toddler reaches hospital the blood pH is usually reduced (< 7.35). The compensatory hyperventilation of metabolic acidosis adds to the stimulant effect of salicylate on the respiratory

centre so that the overbreathing of the poisoned child is often extreme. A side effect of salicylate overdosage is fever. There is also a disturbance of carbohydrate metabolism and the blood glucose may rise above 11.1 mmol/L (200 mg/100 ml) although not above 16.7 mmol/L (300 mg/100 ml). Hypoglycaemia has been recorded but it is uncommon.

The child with salicylate poisoning shows peripheral vasodilatation until near to death. Death is preceded by cyanosis, twitching, rigidity and coma.

### Case Study

A 12-year-old boy presented with severe ichthyosis. He was treated with topical 2% salicylic acid in simple cream applied to the whole body twice daily. The salicylate concentration was increased to 5% on day 3 of treatment and 10% on day 5. On day 8 he developed symptoms of salicylate toxicity. His blood salicylate level was 3.3 mmol/L. Topical salicylate treatment was stopped. Intravenous fluids and bicarbonate were given and complete clinical and biochemical recovery was achieved after 2 days.

This case illustrates that significant percutaneous salicylate absorption can occur especially when salicylate preparations of increasing strength are used.

*Diagnosis:* Salicylate poisoning in dermatological treatment.

### Treatment

The immediate treatment is gastric emptying. So gastric lavage can be undertaken up to 4 hours after ingestion. Also activated charcoal should be given to those patients who have ingested sustained release salicylate preparations.

On arrival at hospital blood is taken for estimation of the plasma salicylate level, electrolytes, renal function, blood glucose, clotting profile and acid base status. However, repeated salicylate measurements are necessary and reliance should not be placed on a single salicylate level. The salicylate levels will usually rise over the first 6 hours if enteric-coated preparation is ingested.

Urinary alkalinisation enhances excretion of salicylates, sodium bicarbonate should be infused over 4 hours. Patients with unresponsive acidosis, convulsions, coma, renal failure or continuing deterioration should be considered for haemodialysis. Haemoperfusion is not recommended. Forced diuresis is no longer used.

## PARACETAMOL POISONING

While paracetamol accounts for a large number of attempted suicides in adults (either alone or in combination with dextropropoxyphene as “Co-proxamol”, cases of serious poisoning are rare in children. Paediatric paracetamol elixir preparations ingested by the toddler very rarely cause toxicity. Nonetheless, as it can lead to irreversible liver and renal failure, any child who may have ingested in excess

of 150 mg/kg should be admitted to hospital without delay. However, children are more resistant to paracetamol-induced hepatotoxicity than adults. Doses of less than 150 mg/kg will not cause toxicity except in a child with hepatic or renal disease.

### Clinical Features

The first symptoms are nausea, vomiting and abdominal pain. Evidence of severe liver damage may be revealed by elevated levels of aspartate aminotransferase (AST) and alanine aminotransferase (ALT) over 1,000 IU/L and of renal impairment by a plasma creatinine concentration over 300  $\mu\text{mol/L}$  (3.4 mg/100 ml). Liver damage is maximal 3–4 days after ingestion and may lead to encephalopathy, haemorrhage, hypoglycaemia, cerebral oedema and death.

### Treatment

Correct treatment of paracetamol poisoning includes oral activated charcoal and a paracetamol blood level to be taken 4 hours following ingestion. Plasma concentrations measured in less than 4 hours cannot be interpreted. Specific treatment is with intravenous infusion of N-acetylcysteine. It is most effective if given within 8 hours of ingestion, after which effectiveness declines. Nomogram shows the level of blood paracetamol at which acetylcysteine should be given intravenously (Fig. 19.1). Those whose plasma-paracetamol concentration is above the normal treatment line are treated with acetylcysteine by intravenous infusion (or, if acetylcysteine is not available, with methionine by mouth, provided the overdose has been taken within 10–12 hours and the child is not vomiting). If the treatment was started within 8 hours of ingesting the overdose, the risk of liver or renal damage is insignificant. Also plasma-paracetamol concentration may be difficult to interpret when paracetamol

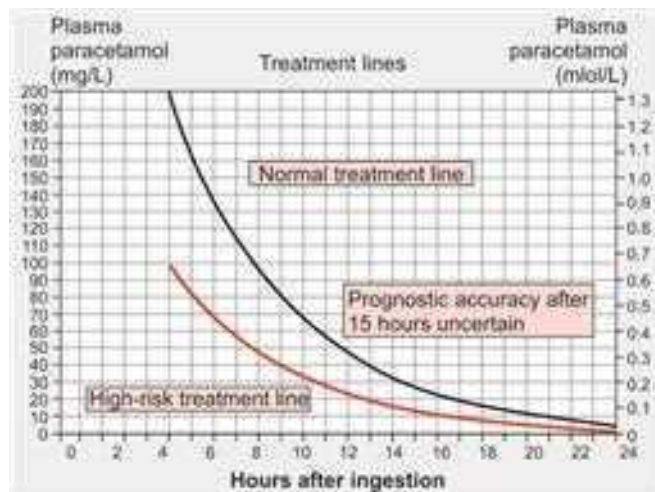


Fig. 19.1: Nomogram for use in paracetamol ingestion

has been ingested over several hours (staggered overdose). However, if there is doubt about timing or the need for treatment then the child should be treated with acetylcysteine.

### IBUPROFEN

Overdosage with ibuprofen may cause nausea, vomiting, epigastric pain and tinnitus, but more serious toxicity is very uncommon. Activated charcoal followed by symptomatic measures are indicated if more than 400 mg/kg has been ingested within the preceding hour.

### ACUTE IRON POISONING

Iron poisoning is most common in childhood and is usually accidental. The most common source of acute iron poisoning is ferrous sulphate tablets, which the young child mistakes for sweets. Other ferrous salts such as gluconate or succinate are less dangerous. If over 20 mg/kg of elemental iron has been taken, toxicity is likely. Over 150 mg/kg may be fatal.

### Clinical Features

The symptoms are vomiting, diarrhoea, haematemesis, melaena, pallor and metabolic acidosis. Hypotension, coma and hepatocellular necrosis occur later. Coma and shock indicate severe poisoning.

#### Case Study

A 2½-year-old Asian boy was found with an empty bottle of ferrous sulphate tablets (ferrous sulphate 200 mg containing 65 mg of ferrous iron). His mouth was full of crushed pieces of tablets. His mother took him to a nearby paediatric A and E unit. On examination he had a temperature of 98.4°C, pulse 120/min, respiratory rate 40/min and blood pressure 90/55 mmHg. He was drowsy; otherwise clinical examination was unremarkable. Hb 12.6 g/dl, WBC and platelet count normal, U and E's and LFT's normal,  $\text{HCO}_3^-$  16 mmol/L and serum iron 60  $\mu\text{mol/L}$ .

He was gastric lavaged with normal saline. He was treated with desferrioxamine 15 mg/kg per hour intravenously for 24 hours. He did not develop any complications and recovered unscathed. He was discharged home, well, 2 days later.

### Treatment

On arrival in hospital gastric lavage should be performed with 1% solution of sodium bicarbonate. Activated charcoal is not helpful. X-ray of the abdomen may help substantiate the number of tablets ingested and a repeat X-ray will demonstrate whether or not gastric emptying has been complete. If large quantities have been consumed, WBI should be considered.

The serum iron concentration is measured as an emergency and intravenous desferrioxamine is given to chelate absorbed



iron in excess of the expected iron binding capacity. In severe toxicity, intravenous desferrioxamine should be given immediately without waiting for the serum iron level. Desferrioxamine has been demonstrated to be safe. If severe impairment of renal function develops, haemodialysis should be considered.

## BARBITURATE POISONING

Barbiturates are now much more commonly prescribed and are rarely encountered as a cause of poisoning in children.

### Clinical Features

In most cases the child is only extremely drowsy. Infrequently, the child may be flushed, excited, restless and may vomit. In severe cases the child is comatose, unresponsive to stimuli and may show respiratory depression with cyanosis, absence of deep reflexes and circulatory failure with hypotension. Skin blisters mainly over bony prominences, peripheral nerve pressure lesions may develop.

### Treatment

For those who have ingested more than 25 mg/kg within 1 hour give activated charcoal 1 g/kg by mouth or via nasogastric tube. Forced diuresis is ineffective and potentially dangerous. Haemodialysis is of no value.

## POISONING BY ANTIHISTAMINES

The common prescribing of antihistamines of many kinds has, unfortunately, increased the opportunity for young children to ingest them accidentally. There is sometimes a fairly long period between ingestion and the appearance of symptoms. These include anorexia, progressive drowsiness, stupor and signs such as incoordinated movements, rigidity and tremor. Poisoning by two of the newer non-sedating antihistamines, terfenadine and astemizole may predispose to the development of ventricular tachyarrhythmias.

### Treatment

Activated charcoal should be considered up to 4 hours post-ingestion, as gut motility is impaired. Treatment is otherwise largely supportive.

## POISONING BY TRICYCLIC AND RELATED ANTIDEPRESSANTS

The frequent use of antidepressants for adults has resulted in a rapidly increasing incidence of their accidental ingestion by children. Moreover, these drugs are prescribed for enuresis in children and the fact that overdosage can produce

dangerous toxic effects in a young child is not sufficiently stressed to the parents.

### Clinical Features

Mildly affected children develop drowsiness, ataxia, abnormal postures, agitation when stimulated, dilated pupils and tachycardia. Thirst and nystagmus have been present in some cases. In severely affected children convulsions may be followed by coma and severe respiratory depression. Cardiac arrhythmias such as ventricular tachycardia and various degrees of heart block with profound hypotension in children are prominent and dangerous.

### Treatment

As there is no known antidote, the management of poisoning with the tricyclics is mainly symptomatic. Activated charcoal should be administered within 1 hour of the overdose, as it reduces absorption of the drug. In addition, alkalisation up to an arterial pH of at least 7.5 has been shown to reduce cardiac toxicity. This can be achieved by hyperventilation and by infusing sodium bicarbonate in a dose of 1 mmol/kg.

The cardiac rhythm should be continuously monitored by electrocardiography. If cardiac arrhythmias develop they can be treated with antiarrhythmic measures. Life-threatening arrhythmias may respond to cardioversion. Intravenous lorazepam or diazepam (preferably in emulsion form) may be required to treat convulsions.

## ATROPINE POISONING

This type of poisoning may arise from ingestion of the plant 'deadly nightshade'. It may also occur when drugs such as tincture of belladonna, atropine or hyoscine are taken accidentally or prescribed in excessive doses. Antidiarrhoeal agent Lomotil that contains diphenoxylate and atropine is toxic to some children at therapeutic dosage.

### Clinical Features

The onset of symptoms is soon after ingestion, with thirst, dryness of mouth, blurring of vision and photophobia. The child is markedly flushed with widely dilated pupils. Tachycardia is severe and there may be high fever. Extreme restlessness, confusion, delirium and incoordination are characteristic. In babies there may be gross gaseous abdominal distension. In fatal cases circulatory collapse and respiratory failure precede death.

### Treatment

This can only be symptomatic and supportive. Gastric lavage followed by the instillation of activated charcoal is effective.

## ANTIMALARIALS

Overdosage with antimalarial drugs such as quinine, chloroquine or hydroxychloroquine is extremely difficult to treat. Life-threatening manifestations include arrhythmias and convulsions which can be intractable.

## POISONING BY DIGOXIN

The increasing number of older adults taking digitalis preparations in the community is resulting in accidental ingestion by children of cardiac glycosides. The most commonly involved preparation is digoxin. Children require treatment if they have ingested more than 100 µg/kg body weight. The toxic effects may not become marked for some hours and it is important to treat every case as potentially dangerous.

### Clinical Features

The most striking presenting feature is severe and intractable vomiting which is largely due to the action of digoxin on the central nervous system. Other neurological manifestations include visual disturbances, drowsiness and convulsions, which are usually delayed for several hours in their appearance. The cardiac manifestations of digoxin intoxication in a previously healthy child are exaggeration of normal sinus arrhythmia which is a common early finding, and sinus pauses with nodal escape beats may occur. Other findings include sinus bradycardia, nodal rhythm, coupled idioventricular rhythm and complete heart block.

### Treatment

Treatment in the first instance is with activated charcoal. Repeated doses may be required. The electrocardiograph should be continuously monitored and the serum electrolytes frequently measured because hyperkalaemia may aggravate digoxin toxicity. Hyperkalaemia should be corrected using ion exchange resins, glucose and insulin or dialysis. Salbutamol and calcium infusions should be avoided because of their potential to destabilise the myocardium.

Bradyarrhythmias may require treatment with atropine or cardiac pacing. Tachyarrhythmias may respond to lignocaine or phenytoin. Cardioversion should be used only as a last resort because of the possibility of inducing asystole. Digoxin-specific antibody fragments are indicated for the treatment of known or strongly suspected digoxin or digitoxin overdosage, where measures beyond the withdrawal of the cardiac glycoside and correction of any electrolyte abnormality are felt to be necessary. Exchange transfusion, peritoneal dialysis and haemodialysis are of no value because most of the drug is tissue bound and plasma concentrations are low.

## POISONING BY PETROLEUM DISTILLATES, INSECTICIDES AND WEED-KILLERS

Ingestion of petroleum distillates is a common childhood problem because they are readily available in most households, including developing countries where kerosene, in particular, is used for heating, cooking and lighting. Petroleum distillates (petrol, paraffin, turpentine, turps substitute, white spirit and kerosene) cause irritation of mucous membranes, vomiting and diarrhoea, when ingested, and respiratory distress, cyanosis, tachycardia and pyrexia, when inhaled. Ingestion of more than 1 mg/kg body weight will cause drowsiness and depression of the central nervous system. Emetics and gastric lavage are contraindicated because they increase the risk of hydrocarbon pneumonia in which there may be pulmonary oedema and haemorrhage. Children can develop symptoms up to 24 hours following ingestion. There is no evidence to support the use of steroids in the treatment of lipid aspiration pneumonitis. Antibiotics should be reserved for those who develop proven secondary bacterial infection.

Chlorinated hydrocarbon insecticides such as DDT, dieldrin, aldrin and lindane can be absorbed through the skin and respiratory tract as well as from the gastrointestinal tract and can cause salivation, abdominal pain with vomiting and diarrhoea, and central nervous system depression with convulsions. Contaminated clothing should be removed, the child washed with soap and water and convulsions treated with diazepam.

Organophosphorus insecticides such as malathion, chlordane, parathion, phosdrin and tetraethyl pyrophosphate are cholinesterase inhibitors, which can also be absorbed from skin, lungs and intestines. The accumulation of acetylcholine in tissues causes nausea, vomiting, diarrhoea, blurred vision, miosis, headache, muscle weakness and twitching, loss of reflexes and sphincter control, and finally, loss of consciousness. Treatment is same as for chlorinated hydrocarbons with, in addition, atropine sulphate 0.05 mg/kg given intramuscularly and then pralidoxime, the specific cholinesterase reactivator, in a dose of 25 mg/kg in 10% solution by intravenous infusion at a rate not exceeding 5 mg/min. Pralidoxime is only of use if administered within 24 hours of exposure; after this the enzyme inactivation becomes increasingly irreversible. During transfer to a paediatric unit provision for intubation and assisted ventilation must be available.

Weed-killers of the paraquat type may also be absorbed through skin, respiratory tract and intestinal tract particularly when concentrated solutions of paraquat have been swallowed; children can experience a burning sensation in the mouth, nausea, vomiting, abdominal pain and diarrhoea, which may be bloody. Hours later, ulceration of the mouth,

throat and gastrointestinal tract may occur. The absence of initial symptoms does not exclude a diagnosis of paraquat poisoning.

When low to moderate doses of paraquat have been ingested the signs of kidney and liver damage may occur after 2–3 days. Both types of damage are irreversible. After 5–10 days, or very occasionally up to 14 days after poisoning, the child may develop signs of lung damage, which is almost always irreversible. When relatively large doses of paraquat are ingested, multiorgan damage and failure occurs quickly and death usually occurs within a few hours or days. Tissue damage is probably caused by local hydrogen peroxide and this might be aggravated by giving oxygen to breathe. Paraquat absorption can be confirmed by a simple qualitative urine test.

The single most useful measure is oral administration of activated charcoal. Gastric lavage is of doubtful value.

## ACUTE ALCOHOL POISONING

Episodes of acute alcohol (Ethanol) poisoning occur predominantly in infancy and preadolescence with peaks at ages 3 and 12 years and are commoner in boys. In the younger age group, ease of access to spirits and fortified wines allied with poor parental surveillance in the home are important factors. Household ethanol sources include perfumes, colognes, aftershaves, mouthwashes and antiseptics. In the older children the episodes are more likely to occur outside the home, thus increasing the risks of physical danger from accidents and hypothermia. The younger infants are at risk of significant hypoglycaemia especially if they drink alcohol in the early morning after an obligate overnight fasting. The lethal dose of ethanol in children is only 3 g/kg, compared with the adult lethal dose of 5–8 g/kg.

### Clinical Features

Nausea, accompanied by vomiting, ataxia and progressive loss of consciousness are the usual features. Aspiration pneumonia, hypoxic and alcoholic brain damage with cerebral oedema, hypothermia, hypoglycaemia and convulsions are not uncommon complications.

### Diagnosis

This is based predominantly on history and on the finding of an elevated blood alcohol concentration. The blood glucose concentrations must be measured.

### Treatment

Activated charcoal does not prevent absorption and is not indicated. Because ethanol is rapidly absorbed from the stomach, performing gastric lavage is unlikely to be of benefit.

Flumazenil and intravenous naloxone have been tried to antagonise the depressant effects of ethanol overdose. Haemodialysis has been used to treat patients with a high blood alcohol level (> 300 mg/dl).

## LEAD POISONING

Lead is usually ingested in small quantities over a long period and the manifestations of poisoning develop insidiously. There are various possible sources of lead such as lead-containing paint which may be used on a child's cot, flakes of paint from plasterwork or woodwork in old Victorian houses, burnt out lead batteries or swallowed pieces of yellow crayon and lead water pipes. Pica is common in children suffering from lead poisoning and is a valuable clue to the diagnosis. It is more common in children from the poorest homes. Asian mothers, mainly for cosmetic reasons, apply Surma, which contains lead sulphide, to the eyelids and conjunctivae of infants and children. It seems that an appreciable absorption of lead in these children occurs from drainage down the tear duct or from rubbing the eyes and then licking the fingers. Other sources of environmental lead contamination are the gasoline exhaust fumes of motorcars and lead in soil. An early diagnosis is extremely important in lead poisoning because, if it is left untreated, lead encephalopathy may result in death or permanent brain damage. Lead poisoning is now defined as a blood lead level equal to or greater than 10 µg/dl (0.50 µmol/L).

### Clinical Features

The earliest signs such as lethargy, anorexia, vomiting and abdominal pain are too common to arouse suspicion in them, but their persistence without other discoverable cause should do so. The pallor of anaemia is a frequent and characteristic sign. Insomnia and headache frequently precede the onset of lead encephalopathy with convulsions, papilloedema and a cracked-pot sound on percussion of the skull. Radiographs of the skull may then reveal separation of the sutures. Peripheral neuropathy is uncommon in the young child but may develop with paralysis of the dorsiflexors of either the wrist or foot. Radiographs of the bones may show characteristic bands of increased density at the metaphyses (Fig. 19.2.) but this is a relatively late sign and, therefore, of limited diagnostic value. Excess aminoaciduria is a common manifestation of renal tubular damage and glycosuria may also occur. Renal hypertension has also been reported. Elevated blood lead levels are also associated with neurodevelopmental abnormalities, behavioural disturbances, learning disabilities, and defects in fine and gross motor development.

The most dangerous development, both in regard to life and future mental health, is lead encephalopathy. Depending



**Fig. 19.2:** Radiograph of lower limbs in chronic lead poisoning. Note bands of increased density “lead lines” at metaphyseal ends of the long bones

upon the amount of lead ingested, this dreaded complication may develop quite quickly or only following a long period of relatively mild ill health.

### Diagnosis

The diagnosis of lead poisoning can be justified in the presence of two or more of the following findings:

- Microcytic hypochromic anaemia with punctate basophilia
- Radio-opaque foreign bodies in the bowel lumen and lines of increased density at the growing ends of the long bones
- Coproporphyrinuria
- Renal glycosuria and aminoaciduria
- Raised intracranial pressure and protein in the cerebrospinal fluid

Interpretation of the blood lead concentration is, unfortunately, much more difficult. While levels below 1.9 mmol/L (40 mg/100 ml) exclude lead poisoning and levels in the region of 2.9 mmol/L (60 mg/100 ml) are associated with clinical signs, it is possible that behaviour and learning difficulties occur at values between these levels.

### Treatment

It is essential that the child be immediately removed from all sources of lead. Deposition of lead in the bones should be encouraged by giving a diet rich in calcium, phosphorus and vitamin D thereby lowering the level of lead in the blood. The most important measure is to increase the excretion of lead in the urine. In chronic lead poisoning the chelating agent of choice is probably D-penicillamine. It has the advantage of being extremely effective when given orally. A suitable

dose is 20 mg/kg per day for 7 days. Further courses may be required if the blood lead level rises again or if symptoms recur.

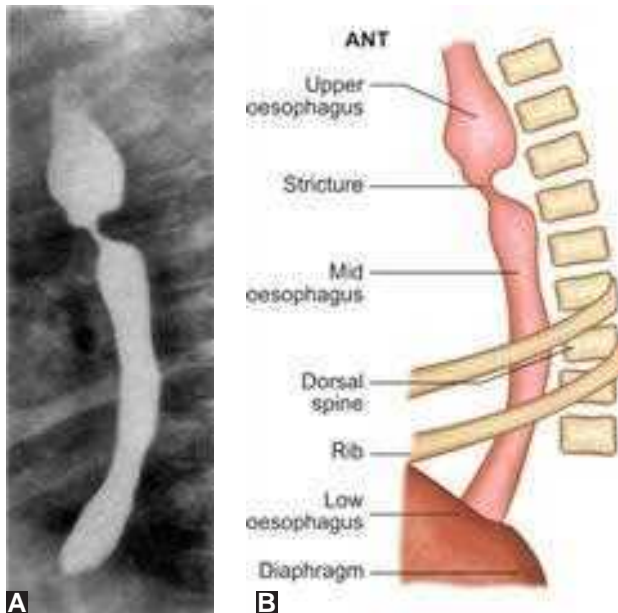
In lead encephalopathy, combination of lead with sulphhydryl groups leads to inhibition of intracellular enzyme systems. The resultant cellular injury is followed by oedema, which adds further injury to the brain. The most effective and rapid method of removing lead from the brain is by the parenteral administration of sodium calcium edetate (calcium disodium versenate; CaEDTA). This therapy is combined with measures to diminish cerebral oedema. As soon as the diagnosis has been made CaEDTA 80 mg/kg per day (0.4 ml/kg per day) is given intravenously in four divided doses per 24 hours for 5–7 days. The CaEDTA should be given by adding each dose to 250 ml of 5% dextrose solution, which is given by intravenous infusion. A second course of CaEDTA should be given some 1–10 days after the end of the first course. Subsequent courses may be required if the blood level remains elevated, or at this stage, oral D-penicillamine might be employed as described above.

The dangers of cerebral oedema are sufficiently great to demand palliative measures while CaEDTA is being used. Various measures, including surgical decompression, have been tried in this emergency. Mannitol is the safest and most effective agent. It can be given in a dosage of 2.5 g/kg by intravenous infusion of a 20% solution. Dexamethasone has also been advised by the intravenous route in doses of 1 mg/kg per day given in four equal six-hourly injections for 48 hours. Once lead encephalopathy has been allowed to develop, the risks to life and subsequent mental development are very great.

### CAUSTIC INGESTION

Accidental ingestion of caustic substances by inquisitive toddlers may result in serious injury to the mouth, oropharynx, oesophagus or stomach. The most corrosive and commonly ingested caustics are the liquid form of sodium or potassium hydroxides used as drain cleaners. Other less caustic alkalis, which may be ingested, are bleach (sodium hypochlorite), laundry and dishwasher detergents, and disinfectants usually kept in the kitchen.

Ingestion of these substances is most likely to result in injury to the oesophagus, but if ingested in large amounts, they can produce extensive damage to the upper gastrointestinal tract. If the hydroxide concentration is high it may lead to perforation of the oesophagus and thus penetration into the perioesophageal tissues, which may cause mediastinitis. The presence of oral burns confirms that ingestion of a caustic substance has taken place but it does not suggest the degree of oesophageal damage. Dyspnoea, stridor or hoarseness suggests laryngeal injury. Products that become trapped in



**Figs 19.3A and B:** Oesophageal stricture: Barium swallow showing short smooth stricture secondary to caustic ingestion

the oesophagus cause the most damage, e.g. batteries or dishwasher tablets.

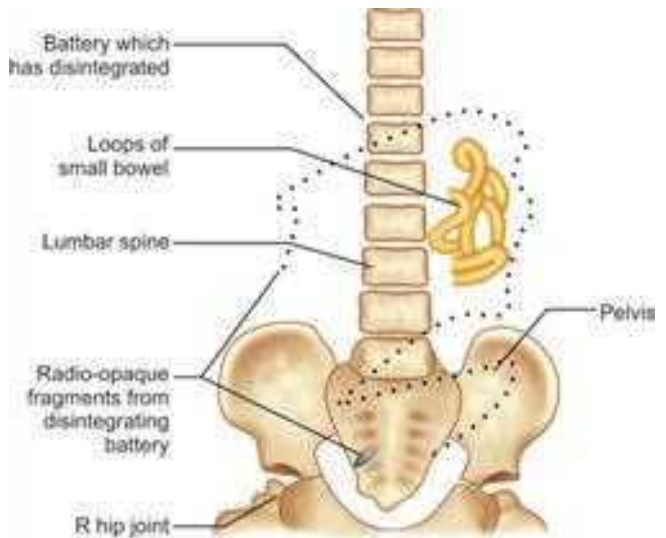
### Treatment

All children with caustic ingestion should be admitted for observation of at least 24 hours. The outcome for most children following corrosive ingestion is good. Attempts at neutralisation of corrosives or gastric decontamination should be avoided.

Persistence of drooling and dysphagia after 12–24 hours of ingestion are indications of oesophageal scar formation and warrants upper gastrointestinal endoscopy (Figs 19.3A and B). It seems that steroid treatment does not minimise the formation of scar tissue and stricture. Children with oesophageal stricture usually respond to repeated dilatations but some require oesophageal replacement surgery.

## SWALLOWED FOREIGN BODIES

Foreign body ingestion is common in children because they have a tendency to explore and to taste new objects and, thus, they swallow bizarre and multiple objects. Most foreign bodies swallowed pass through the alimentary tract without symptoms. However, if the foreign body is lodged in the oesophagus, it should be removed immediately through an endoscope to avoid serious complications of oesophageal obstruction, asphyxia or mediastinitis. In the absence of symptoms, the management simply consists of an X-ray of the abdomen to confirm the presence of a radio-opaque



**Figs 19.4A and B:** X-ray of abdomen showing disintegrating battery

object and a careful watch kept on the stools until the foreign body is recovered.

Disc batteries (button batteries) are often ingested in young children these days due to their widespread use in electrical products in the home. These batteries contain alkalis in sufficient concentration to cause caustic injuries and mercury in sufficient quantities to create problems. However, the highly toxic mercuric oxide is converted to essentially nontoxic elemental mercury on leakage or complete disintegration of the battery (Figs 19.4A and B). In addition, mercuric oxide is poorly soluble and not well absorbed and this may account for the very low incidence of mercury poisoning and, therefore, children may not need

chelation therapy. The vast majority of battery ingestions is benign and can be managed without endoscopic or surgical intervention. Evaluation and treatment of the burns caused by the battery is the same as that for other alkali burns (see caustic ingestions). Batteries lodged in the oesophagus must be removed by endoscopic means. If they have recently passed into the stomach, purgation can speed their passage, if, however, they have been in the stomach for more than 3 hours their removal by endoscopy is essential. However, it is less likely for the battery to produce obstruction as it would have been disintegrated and, therefore, removal by endoscopy may not be required.

## ACUTE CARBON MONOXIDE POISONING

Carbon monoxide (CO) is an odourless, colourless gas and its poisoning causes hypoxia, cell damage and death.

Carbon monoxide is produced by the incomplete combustion of carbon containing fuel, such as gas (domestic or bottled), charcoal, coke, oil and wood. Gas stoves, fires, car exhaust fumes, paraffin heaters are all potential sources.

The symptoms of CO poisoning are nonspecific and include headache, fatigue, confusion, nausea, dizziness, visual disturbances, chest pain, shortness of breath, loss of consciousness and seizures. The classical signs of CO poisoning, such as cherry-red lips, peripheral cyanosis and retinal haemorrhages, are uncommon. A carboxyhaemoglobin level of 10% or more or the presence of clinical signs and symptoms after known exposure to CO are indicative of acute CO poisoning.

### Treatment

The child should be moved to fresh air, the airway cleared and oxygen 100% administered as soon as available. High concentrations of oxygen hasten the dissociation of carboxyhaemoglobin. Patients with neurological signs or symptoms or those with evidence of cardiovascular abnormalities may need hyperbaric oxygen therapy. Unconscious patients should have early cranial imaging and may need aggressive treatment to control cerebral oedema.

## SNAKE BITE

Snake bite is a major medical problem in many parts of the world. The snakes of medical importance are the vipers (e.g. carpet viper, Russell viper, adder, etc.) and the elapids (cobra, mamba, krait, etc.). In the Indian subcontinent, the most important species are cobra, common krait, Russell's viper, but in South East Asia the Malayan pit viper, green pit viper and the monocellate cobra cause most bites and deaths. In Britain, the adder or viper is the only venomous species.

## Clinical Manifestations

The earliest symptoms related to the bite are local pain, bleeding from the fang puncture, followed by swelling and bruising extending up to the limb, and tender enlargement of regional lymph nodes. Clinical effects of systemic envenoming usually involve haemorrhage and coagulation defects resulting in incoagulable blood. Systemic elapid poisoning usually causes neurotoxic effects, which, in untreated cases, results in ptosis and life-threatening paralysis of the respiratory muscles. In victims of envenoming by sea snakes and Russell's vipers in Sri Lanka and South India, muscles become tender and painful and develop myoglobinuria. In rural and coastal regions of India and Thailand, snake bite is a frequent cause of acute renal failure.

## Management of Snake Bite

### First Aid and Resuscitation

The first aid treatment should be carried out immediately or very soon after the bite. The bitten limb should be immobilised as far as practicable with a splint or sling. Most of the traditional first aid methods are potentially harmful and should not be used. As far as the snake is concerned, do not attempt to kill it, as this may be dangerous. However, if already killed, it should be taken to hospital with the patient so that it may be identified. Cardiopulmonary resuscitation may be needed including administration of oxygen and establishment of intravenous access. Airway, respiratory movements (breathing) and circulation must be checked immediately.

### Antivenom Treatment

The most important decision in the management of a patient bitten by a snake is whether or not to give antivenom, the only specific treatment for envenoming. There is abundant evidence to suggest that with severe envenoming, the benefits of this treatment outweigh the risks of antivenom reactions.

Antivenom is indicated if there are signs of systemic envenoming, local swelling involving more than half the bitten limb, extensive blistering or bruising, bites on digits and rapid progression of swelling. Monovalent or monospecific antivenom neutralises the venom of only one species of snake. Polyvalent or polyspecific antivenom neutralises the venoms of several different species of snakes, usually the most important species from a medical point of view in a particular geographical area. The dose of antivenom should not be based on the patient's size, but on the amount required to neutralise the toxin; thus in general, children should receive the full adult dose.

**Key Learning Point****Snake bite antivenom treatment**

- ➔ Children should be given the same dose of antivenom as adults.

There is no absolute contraindication to antivenom treatment, but those who have reacted to horse or sheep serum in the past and those with a strong history of allergic disease should be given antivenom only if they have signs of systemic envenoming. However, allergic reactions to antivenom may be prevented or ameliorated by pre-medication with subcutaneous adrenaline (epinephrine) 5–10 µg/kg. Additional protective agents such as hydrocortisone and an antihistamine may be indicated.

Patients who suffer a snake bite and have not been immunised against tetanus within the last 5 years should receive anti-tetanus toxoid.

**INSECT STINGS**

Stings from ants, wasps, hornets and bees cause local pain and swelling but seldom cause severe toxicity unless many stings are inflicted at the same time. If the sting is in the mouth or on the tongue, local swelling may threaten the upper airway. The stings from these insects are usually treated by cleaning the area. Bee stings should be removed as quickly as possible. Anaphylactic reactions require immediate treatment with intramuscular adrenaline (epinephrine), self-administered (or given by a carer). Intramuscular adrenaline (e.g. EpiPen) is the best first-aid treatment for children with severe hypersensitivity. A short course of an oral antihistamine or a topical corticosteroid may help to reduce inflammation and relieve itching.

**MARINE STINGS**

Children stung by jellyfish should be removed from the sea as soon as possible. Adherent tentacles should be lifted off or washed off with seawater. Ice packs will reduce pain and a slurry of baking soda (sodium bicarbonate) but not vinegar, may be useful for treating stings.

**PLANT AND MUSHROOM POISONING**

Plants found in the home, garden and field now constitute the most common source of ingested poison in children. The fruits, seeds or roots of many common plants are poisonous. Fortunately, poisonous plants are rarely ingested in quantities sufficient to cause serious illness. However, the symptoms of poisoning from plants can include:

- Vomiting
- Stomach cramps

- Irregular heart beat
- Burning to the mouth
- Convulsions.

The type and severity of symptoms will vary according to the type of plant eaten. Any amount of any wild mushroom is considered to be very dangerous (Box 19.6 for symptoms of mushroom poisoning). Deliberate ingestion of magic mushroom is also a potential source of poisoning. Identification of the plant must be attempted early and a computerised database can be accessed through the poisons centres.

**Box 19.6:** Symptoms of mushroom poisoning: Symptoms typically appear 6–8 hours after eating but the symptoms can develop as soon as 2 hours and as late as 12 hours after ingestion

- Bloating feeling
- Nausea and vomiting
- Watery or (bloody) diarrhoea
- Muscle cramps
- Abdominal pain

*Severe cases can include:*

- Liver damage, high fever, convulsions and coma
- Death (usually 2–4 days after ingestion)

Caution should be used in accepting common names of plants or in identifying a plant from a verbal description of its fruit or foliage. If substantial doubt exists, a portion of the plant should be brought for identification. However, each plant ingestion in a child must be viewed as potentially toxic until the plant has been positively identified or sufficient time has passed for a conclusion on nontoxicity. There is no way to tell by looking at a plant if it is poisonous.

**DROWNING AND NEAR DROWNING**

Drowning is defined as death, if the child dies within 24 hours as a result of a submersion accident and a near drowning accident if the child survives at least 24 hours after an episode of submersion. Drowning is now the most common cause of accidental death in children for a water-oriented society. Most drownings and near-drownings occur in the age group of 1–2 years.

The complications of drowning are directly related to anoxia and to the volume and composition of water that is aspirated. Both fresh and salt water damage alveoli and result in pulmonary oedema. The most important complication of near-drowning accidents in addition to pulmonary injury is the anoxic-ischaemic cerebral damage. As soon as water has entered the mouth it causes the epiglottis to close over the airway. Without oxygen, the child will lose consciousness. Thereafter bradycardia, cardiac arrhythmias, cardiac arrest and death occur.

**Treatment**

The single most important step in the treatment is the immediate institution of cardiorespiratory resuscitative

measures at the earliest possible opportunity. Oxygen at the highest concentration available should be provided as soon as possible.

A deep body temperature reading (rectal or oesophageal) should be obtained as soon as possible. External rewarming is usually sufficient if core temperature is above 32°C but active core rewarming should be implemented if the core temperature is less than 32°C.

Resuscitation should not be abandoned until core temperature is at least 32°C or cannot be raised despite active measures. The decision to stop resuscitation should be taken

only after all prognostic indicators have been considered (Box 19.7).

**Box 19.7:** Prognostic markers in children with drowning

- Submerged in water for more than 3–8 minutes
- No gasp after 40 minutes of full CPR
- Persisting coma
- Arterial blood pH less than 7.0 despite treatment
- Arterial blood PO<sub>2</sub> less than 60 mmHg despite treatment

There is no evidence that osmolality specific (salt versus fresh water) drowning affects the probability of survival.



# Metabolic Diseases

## INBORN ERRORS OF METABOLISM

There has been a remarkable increase in our knowledge of the inborn metabolic errors in recent years, largely brought about by the introduction of new biochemical techniques. The term "inborn errors of metabolism (IEM)" was first used by Garrod in 1908 when he described albinism, alkaptonuria, cystinuria and pentosuria. Garrod, noting the frequency of consanguineous matings in the pedigrees of his patients, correctly inferred the genetic origin of these disorders. He went further and suggested that they arose through the medium of defective enzyme activities. At the present time there are over 1,500 known recessive and X-linked human genetic diseases, all of which can be expected to have an underlying specific inherited metabolic disorder. So far in only about 200 is the precise enzyme defect known, although the chromosomal location of more than 700 of these genes is now known.

In this book, it would clearly be impracticable to consider the whole subject. Instead, an attempt has been made to portray a broad outline through three sections: (1) common aetiological principles, (2) clinical approach to diagnosis and then (3) a variety of common specific conditions are covered in more detail. Some others are considered in other chapters under the various systems of the body.

## COMMON AETIOLOGICAL PRINCIPLES

Our genes act through the control of complex intracellular biochemical reactions. The concept of "one gene-one enzyme" is now firmly established. Thus, an abnormal or defective enzyme activity must be related to an abnormal or mutant gene. Our understanding of the nature of gene activity was greatly furthered by the work of Watson and Crick when they described the structure of the deoxyribonucleic acid (DNA) molecule. A gene is composed of DNA and the structure of the DNA molecule determines the specific function of the gene. This structure consists of two helical chains of phosphate-sugar each coiled round the same axis.

The chains are held together by purine and pyrimidine bases, which are at right angles to the axis of the molecule. There are four such nitrogen bases in the DNA molecule—adenine (a purine), thymine (a pyrimidine), guanine (a purine) and cytosine (a pyrimidine). The genetic function is coded, as it were, by the particular sequence of these alternating pairs of purine and pyrimidine bases along the length of the DNA molecule. The activity of the DNA molecules on the chromosomes transmits information to the molecules of ribonucleic acid (RNA) within the cell nucleus. There are also four nitrogen bases in the RNA molecule—adenine, guanine, cytosine and uracil (instead of thymine as in DNA). The RNA or "messenger" molecules then diffuse out into the cytoplasm and pick up individual amino acids which come together to form polypeptide chains and proteins on the ribosomes. The sequence of bases along the RNA molecule is the code, which determines the order of incorporation of amino acids into the particular polypeptide chains. A mutation, therefore, consists of an alteration in the sequence of bases in the DNA molecule and consequently in the RNA molecule. This usually results in the substitution of one amino acid for another in the polypeptide chain. For example, the haemoglobin in sickle-cell anaemia (HbS) differs from normal haemoglobin (HbA) only in that valine occupies the position in the haemoglobin peptide sequence normally occupied by glutamic acid.

In the case of a defective enzyme system, a single amino acid substitution at the active centre of the protein could profoundly alter the kinetics of the catalytic process and so result in loss of activity. The same effect could occur in peptides and protein macromolecules other than haemoglobin and enzymes, and the IEM should now be taken to include all the specific molecular abnormalities, which are genetically determined. They can, for clinical purposes, be divided into four types:

1. Disturbances in structure of protein molecules, e.g. the haemoglobinopathies

2. Disturbances in synthesis of protein molecules, e.g. haemophilia, Christmas disease, congenital afibrinogenemia, congenital hypogammaglobulinaemia, and Wilson's disease (where caeruloplasmin is deficient)
3. Disturbances in function of protein molecules, e.g. enzyme deficiencies like phenylketonuria (PKU), galactosaemia, adrenocortical hyperplasia and many others
4. Disturbances in transport mechanisms, e.g. Hartnup disease, cystinuria, nephrogenic diabetes insipidus, renal glycosuria, de Toni-Fanconi syndrome, vitamin D resistant rickets.

In 1961, the first success was achieved in "breaking the code" which the sequences of base pairs in the DNA and RNA molecules represent. Each amino acid is specified by a set of three bases out of the possible four nitrogen bases in the DNA and RNA molecules. This is a triplet code, which gives  $4^3 = 64$  different possibilities, and each base triplet has been called a "codon". Some examples of the code in relation to the RNA molecule are as follows:

Phenylalanine =	Uracil-Uracil-Uracil
Methionine =	Uracil-Guanine-Uracil
Tryptophan =	Uracil-Guanine-Guanine
Leucine =	Uracil-Uracil-Adenine

A mutation usually involves the addition or deletion of a single base. As this may occur at random anywhere along the base pair sequence, it follows that many different (alternative) genes (or alleles) may be generated by different mutations in any given gene. For example, in a typical gene with 900 nitrogen bases coding a polypeptide chain of 300 amino acids as many as 2,700 different alleles might arise from different mutations, each causing the replacement of a single base. Such a great variety of different mutant alleles are not merely theoretical. Over 300 variants of haemoglobin A have now been identified, the great majority differing from HbA by only a single amino acid substitution, although only a few are associated with overt disease. In the same way, an enzyme protein can be altered in many ways by different mutant alleles, although when they result in the loss of enzyme activity they will all have similar metabolic and clinical consequences.

As the triplet code from four bases gives 64 different possibilities it follows that any one of the 20 amino acids must be able to be coded for by more than one base triplet or codon. It would appear that of the 64 possible triplet sequences 61 each specify one out of the 20 amino acids, and that most amino acids are coded by two or more different base triplets. The remaining 3, sometimes called "nonsense triplets" do not code for any amino acid. They are concerned with chain termination, i.e. they define the point in the synthesis of the polypeptide at which the end of the chain is reached. In the majority of mutations involving a single base change, the base triplet (or codon) for one amino acid is replaced by the base triplet for another resulting in the

substitution of one amino acid for another in the polypeptide chain—as in the abnormal haemoglobins (haemoglobins M). On the other hand, if this single base change is to involve one of the "nonsense triplets" which code for chain termination the result would be the synthesis of a greatly shortened polypeptide chain which would fail to add up to a viable and functional form of protein. The effect could be a complete failure to synthesise the specific enzyme protein or, alternatively, a severe reduction in the rate of its synthesis so that very little is actually present at any one time. In other rare instances complete failure to form the enzyme may arise from a deletion of parts of the DNA sequence of the gene rather than from a single base change.

The basis of many of the IEM is highly complex. There are certain other factors concerned with the activity of any enzyme. This activity is determined by the amino acid sequence which dictates its three-dimensional molecular structure. But the quantity of enzyme present is clearly important and dependent on the relative synthetic versus catabolic ratio in the cell. Enzyme activity is further influenced by the presence of particular activators, inhibitors, co-enzymes, etc. It will become clear in the accounts of some of the individual inborn errors which follow, that these factors may sometimes explain the variations, which are now being demonstrated within diseases previously thought to be more or less uniform in their manifestations.

Diagnosis depends on both, the clinician having a high index of suspicion and the appropriate test(s) being carried out. The local laboratory has a key role to play by guiding these investigations. In certain situations, appropriate preliminary "screening" tests are carried out first; in others, specific analyte measurements are the first line investigation. Many of the more specialised tests (i.e. specific enzymes) will only be required later to confirm a diagnosis.

## TREATABLE DISORDERS

There is an increasing array of specific therapy for different metabolic disorders. Unfortunately, a number of these are very expensive (up to \$400K per annum). This limits their potential use throughout the world and even in Europe their role is restricted. Some treatments are, however, very inexpensive, e.g. pyridoxine for pyridoxine responsive seizures.

### Why Investigate Further?

Even where a disease is untreatable, confirming the specific diagnosis often to DNA mutation level, allows prenatal testing of future pregnancies. In certain cultures, this may not be acceptable, but the more specific the diagnosis the better the risk of future pregnancies can be explained to the parents of an affected child.

## CLINICAL APPROACH TO DIAGNOSIS

Many classifications of IEM were based around a specific metabolite or cellular organelle. An example of the former is disorders of fructose metabolism: (a) essential fructosuria—a benign problem where the proximal convoluted tubule fails to re-absorb fructose resulting in urine testing positive for reducing substances, but glucoStix negative (which uses a specific glucose oxidase method), (b) fructose 1,6-bisphosphatase—rapid onset of hypoglycaemia from failure of gluconeogenesis, 2–3 hours after feeding associated with gross lactic acidemia and (c) hereditary fructose intolerance—severe liver failure may result following ingestion of fructose. An example of organelle disorders is lysosomal disorders: (a) I-cell disease—presenting with hydrops fetalis or early onset dysostosis multiplex, (b) glycogen storage disease (GSD) type II (Pompe's disease)—presenting with cardiac failure or (c) mucopolysaccharidosis (MPS) type IV (Morquio disease)—presenting with coarse features and short stature. Clinically this approach is limited.

A more useful clinical approach has been developed, in which disorders are classified according to common clinical presentation or specific signs, e.g. cherry-red spot on the macula. There are four groups of clinical scenarios where a metabolic disorder should be considered:

1. Acute neonatal presentation, e.g. maple syrup urine disease (MSUD)
2. Late onset acute and recurrent attacks of symptoms such as ataxia, vomiting or acidosis, e.g. female with ornithine transcarbamylase deficiency
3. Chronic and progressive generalised symptoms—usually gastrointestinal (chronic vomiting, failure to thrive); muscular or neurological deterioration, e.g. Refsum disease with ataxia and progressive night blindness
4. Specific and permanent organ presentations suggestive of an IEM, e.g. cataract in galactokinase deficiency.

Approximately 2% of all newborns have an IEM. Within this group, the autosomal dominant conditions usually present in adulthood and are the most common, e.g. familial hypercholesterolemia (~1 in 500). In X-linked conditions, where there is no male to male transmission within a family, females were considered only carriers; increasingly they are noted to have variable features dependent upon lyonisation and the specific organs which have the defective X-chromosome active. However, the vast majority of conditions are autosomal recessive and present before puberty.

Inborn errors of metabolism most commonly present in the neonatal period in full-term and initially apparently healthy neonates. This is the group that is further described in greater detail.

In neonates, IEM either present with a specific organ affected, e.g. cataract, or as a generalised disorder. The

latter group may be classified into predominant neurological, hepatological or dysmorphic presentations.

## Neurological Presentations

Irrespective of the aetiopathogenesis, the neonate has a limited repertoire of signs. Thus, poor feeding, vomiting, temperature instability, apnoea and progressive decline in responsiveness, while strong pointers towards a metabolic disorder, are also all features of more common conditions, e.g. an underlying infection. Specific clues to a metabolic disorder would include abnormal smell [e.g. MSUD, isovaleric aciduria (IVA)], previous sibling death or failure to thrive, or consanguineous marriage.

Neurological presentation can be further subdivided into three: (1) early onset seizures, (2) encephalopathy without acidosis and (3) encephalopathy with acidosis. For most IEM, seizures are a late aspect following progressive signs of encephalopathy.

### Seizures

Seizures associated with IEM are intractable and respond poorly to conventional anti-epileptic therapy. If occurring in the first 4 days of life, they point towards a small group of specific but unrelated disorders, the four commonest being: (1) pyridoxine responsive seizures, (2) non-ketotic hyperglycinaemia, (3) molybdenum co-factor deficiency and (4) peroxisomal disorders. A trial of treatment with pyridoxine is, therefore, appropriate along with consideration of other rarer treatable disorders—congenital magnesium deficiency, folinic acid responsive seizure and biotin responsive seizures.

### Encephalopathy without Acidosis

Maple syrup urine disease and urea cycle disorders are the important disorders included in this group. The clue to the latter is early development of respiratory alkalosis though this may disappear with the onset of severe illness. Aggressive intervention to lower leucine and ammonia concentrations, respectively, may be sufficient to prevent death but varying degrees of permanent neurological deficit is often unavoidable. Definitive diagnosis, however, allows close monitoring of future siblings in early post-natal life where prospective support can lead to a very good clinical outcome.

### Encephalopathy with Acidosis

Three major disorders can present within the first 2 weeks with very negative base excess. The three enzyme deficiencies: (1) holocarboxylase, (2) propionyl CoA carboxylase and (3) methylmalonyl CoA mutase—are differentiated by urine organic acid analysis. Treatment with N-carbamyl glutamate (to reduce hyperammonaemia), biotin,

bicarbonate and dietary protein restriction is associated with clinical improvement. The other group of conditions such as mitochondrial and pyruvate disorders involve hyperlactic acidemia, but are untreatable.

### Hepatological Presentation

This group can also be subdivided into three: (1) jaundice, (2) hypoglycaemia and (3) gross liver dysfunction.

#### Jaundice

Unconjugated hyperbilirubinaemia can occur early in galactosaemia though classically these patients often develop *Escherichia coli* septicaemia and conjugated hyperbilirubinaemia. Other causes of unconjugated jaundice include hypothyroidism, breast milk jaundice and rarely Crigler-Najjar syndrome.

With conjugated hyperbilirubinaemia and failure to thrive, two common diagnoses to consider are alpha 1-antitrypsin deficiency and cystic fibrosis.

#### Hypoglycaemia

While significant hypoglycaemia is usually secondary to hyperinsulinism, progressive liver enlargement and hyperlactic acidemia merit consideration of GSD type I (von Gierke) and fructose 1,6-bisphosphatase deficiency in the differential diagnosis. With milder hepatomegaly associated with features of encephalopathy, acylcarnitine profiling to exclude fatty acid oxidation defects is appropriate.

#### Gross Liver Dysfunction

While viral infections remain a very common and important cause, metabolic disorders such as mitochondrial mutation defects, neonatal haemochromatosis and tyrosinaemia type 1 should be considered in those with gross liver dysfunction presenting with a coagulopathy.

#### Dysmorphological Presentations

These are chronic progressive disorders whose clinical progress is independent of intercurrent illnesses; most are untreatable. The clinical pattern gives the clue to diagnosis: A floppy child with a large anterior fontanelle would suggest Zellweger syndrome (peroxisomal disorder). While infection, haemolytic anaemia and cardiac disease are common aetiologies for hydrops fetalis. Hydrops is also associated with a vast array of metabolic disorders, particularly lysosomal disorders.

Table 20.1 gives a list of initial investigations, which can help categorise the metabolic disorders. More specialised investigations such as amino and organic acid analyses can then be arranged.

If the child dies it is important to have obtained urine, plasma, white blood cell DNA, fibroblast (for culture), and muscle and liver biopsies (stored deep-frozen). Subsequent analyses may help determine the nature of the metabolic defect and allow diagnostic and genetic counselling to be provided to the family.

## SPECIFIC COMMON DISORDERS

### DISORDERS OF AMINO ACID METABOLISM

#### Phenylketonuria

##### Aetiology

"Classical phenylketonuria" (persistent hyperphenylalaninaemia  $> 600 \mu\text{mol/L}$ , relative tyrosine deficiency and excretion of an excess of phenylketones) is transmitted as an autosomal recessive trait, so that in any family in which the disease has appeared the chances of future children being affected will be 1 in 4. Parents of affected children are both asymptomatic carriers. The incidence of the "classical" form of PKU in the United Kingdom is about 1 in 12,000 births. In recent years, the development of sensitive screening tests based upon the estimation of blood phenylalanine has shown that hyperphenylalaninaemia is not necessarily associated with the presence of phenylketones in the urine. The terminology relating to these other types of hyperphenylalaninaemia is confused, as is our understanding of their aetiology and has included such names as atypical PKU, mild PKU,

**Table 20.1:** Initial investigations to help categorise metabolic disorders

Urine	Smell
	Ketones Reducing substances Keto-acids (dinitrophenylhydrazine test) Sulphites (Sulfitest, Merck) pH
Blood	Blood cell count Electrolytes (look for anion gap) Calcium Glucose Blood gases (pH, PCO <sub>2</sub> , HCO <sub>3</sub> , PO <sub>2</sub> ) Ammonia Lactic acid 3-hydroxy butyrate Uric acid
Store at -20°C	Urine (as much as possible) Heparinized plasma (2-5 ml) Do not freeze whole blood! CSF, 0.5-1.0 ml
Miscellaneous	EEG, bacteriological samples, chest X-ray, lumbar puncture, cardiac echography, cerebral ultrasound

phenylalaninaemia, etc. Recent genetic studies have provided an explanation for this variation. Over 150 different mutations of the phenylalanine hydroxylase gene have been identified. Currently all neonates with phenylalanine greater than 240  $\mu\text{mol/L}$  are referred for ongoing management from the screening programme, though treatment is only begun if levels rise above 400  $\mu\text{mol/L}$ .

### Pathogenesis

In normal individuals phenylalanine, which is an essential amino acid, is converted in the liver to tyrosine by the activity of phenylalanine hydroxylase. The gene for phenylalanine hydroxylase is located on chromosome 12 and contains 13 exons. A high proportion of affected subjects are compound heterozygotes rather than homozygotes. In consequence the blood phenylalanine increases and is converted by phenylalanine transaminase to phenylpyruvic acid and other degradation products such as phenyllactic acid, phenylacetic acid and ortho-hydroxyphenylacetic acid. The precise chemical cause for the inevitable mental retardation in "classical" PKU is not known, but is probably related to the high phenylalanine concentration and to deficiencies of the neurotransmitters noradrenaline, adrenaline and dopamine. The fair hair and blue eyes are due to the deficient availability of melanin, which is synthesised like the neurotransmitters from tyrosine (Fig. 20.1).

While various sub-classifications such as "mild" PKU have been described, many western countries now screen for PKU and assess when day 5 phenylalanine levels are greater than 240  $\mu\text{mol/L}$ —a level at which no transamination occurs. Monitoring growth and development while controlled plasma phenylalanine levels allow children to develop into neurologically intact adults. The benefits of lifelong therapy are still being debated.

Several patients have been described with choking attacks, muscular hypotonia, developmental delay and convulsions, and mild to moderate hyperphenylalaninaemia. Liver phenylalanine hydroxylase activities have been normal and there has been continued clinical deterioration in spite of adequate dietary control. In these patients, there is defective synthesis of tetrahydrobiopterin or of biopterin from dihydrobiopterin. As tetrahydrobiopterin is the co-factor for phenylalanine hydroxylase, its deficiency prevents the conversion of phenylalanine to tyrosine even though the phenylalanine hydroxylase enzyme is normal. Deficiencies of tetrahydrobiopterin will also interfere with the conversion of tyrosine to dihydroxyphenylalanine (DOPA) and noradrenaline and the conversion of tryptophan to serotonin, as tetrahydrobiopterin is also a co-factor for the enzymes involved. These tetrahydrobiopterin defects are found in about 1% of hyperphenylalaninaemic children



Fig. 20.1: Untreated phenylketonuria

and treatment is with tetrahydrobiopterin, L-DOPA and L-5-hydroxytryptophan and a peripheral decarboxylase inhibitor. There is a blood spot-screening test available for total blood biopterin and this should be performed in all hyperphenylalaninaemic children.

### Clinical Features

Untreated "classical" phenylketonurics have severe learning disorders (IQ 30 or lower). They are frequently blue-eyed, fair-haired and with fair skins. Eczema is often troublesome. Some have convulsions, athetosis and electroencephalographic changes. Many show psychotic features such as abnormal posturings with hands and fingers, repetitive movements such as head-banging or rocking to and fro and complete lack of interest in people as distinct from inanimate objects. The tendon reflexes are often accentuated. It should be noted that infants born homozygous for the phenylketonuric trait are not brain-damaged at birth. They only become so after they start to ingest phenylalanine in their milk.

### Maternal Phenylketonuria

As a consequence of defects of phenylalanine and tyrosine metabolism in the mother, abnormalities have been reported among a large number of infants of phenylketonuric women. These include mental retardation, microcephaly, congenital heart disease and intrauterine growth retardation. Congenital anomalies are uncommon in the offspring of mothers with phenylalanine concentrations below 600  $\mu\text{mol/L}$  at the time of conception. However, head size, birth weight and intelligence have been shown to be inversely and linearly

associated with maternal phenylalanine concentrations. Phenylalanine concentrations during pregnancy and in the period prior to conception should be maintained between 60 and 250  $\mu\text{mol/L}$ . Effective contraception should be continued until control has been achieved. Biochemical monitoring should be at least twice weekly and careful fetal ultrasound examinations to assess fetal growth and anatomy should be performed. Restriction of maternal dietary phenylalanine with tyrosine supplementation when necessary begun prior to conception controls the blood phenylalanine level and metabolite accumulation in the pregnant mother with PKU just as it does in the child with PKU. Dietary treatment begun after 8th week of conception is much less effective. It is essential, therefore, those women with PKU should be appropriately counselled and supported so that their children are conceived under the best possible phenylalanine control.

### Diagnosis

When it became clear that a low-phenylalanine diet improved the intelligence of patients with PKU, the need for early diagnosis, before intellectual impairment had occurred, was recognised. This requirement demands the "screening" of all newborn infants in a community. Those infants found to give a positive result with the screening test require to be submitted to more detailed confirmatory tests.

*Screening tests:* The urine of an affected infant may be noted to have a mousy smell caused by phenylacetic acid. The presence of phenylpyruvic acid in the urine can be quickly detected by adding a few drops of 5% or 10% aqueous solution of ferric chloride to 5 ml of acidified urine, when a green colour will rapidly develop. Alternatively, a wet napkin can be tested with Phenistix (Ames Co.), which is pressed between two layers of the napkin resulting in the development of a similar green colour. This technique was widely adopted as a screening test in the United Kingdom but was soon shown in practice to have real limitations in that many cases (45%) were missed during the neonatal period. The neonatal screening programmes, which are now used, permit the accurate detection of infants who have raised blood phenylalanine levels from the 5th day of life. The most commonly used screening test for raised blood phenylalanine in the United Kingdom was initially the Guthrie bacterial inhibition test, which has been proved to be extremely reliable. Both the Guthrie test and chromatography can be modified to "screen" for several other inborn errors such as galactosaemia, tyrosinaemia, and homocystinuria and MSUD. Techniques have evolved from Guthrie bacterial inhibition tests to tandem mass spectrometry, which can potentially identify a vast array of conditions. The objective is to identify as soon after birth as possible and before the onset of recognisable clinical symptoms, specific metabolic disorders

that can then be treated to ameliorate the consequences of untreated disease.

*Confirmation of the diagnosis of phenylketonuria:* All infants in whom the Guthrie or other screening test has shown a blood phenylalanine of more than 240  $\mu\text{mol/L}$  (4 mg/100 ml) on two occasions should be further investigated.

### Treatment

Treatment, which should begin as soon as after birth as possible, is focused on restricting the intake of phenylalanine by means of a special diet.

The accepted dietary treatment of PKU consists of reducing the intake of phenylalanine to a level, which will prevent serious hyperphenylalaninaemia. A low-phenylalanine diet cannot fully substitute for the phenylalanine turnover normally exerted by hepatic phenylalanine hydroxylase. As most food proteins contain phenylalanine, it is obvious that a low-phenylalanine diet must be largely synthetic and consequently expensive. Such a diet is complex and depends on the use of manufactured substitutes for many natural foods. There is strong evidence that phenylalanine restriction can prevent mental retardation if treatment is started during the first 3 weeks of life. In health systems with established neonatal screening programmes, the untreated older sufferer from PKU is a rarity.

The low-phenylalanine feed is fed to satiety although care must be taken to ensure that the infant's nutritional needs are met. Breast-fed infants obtain phenylalanine from their mother's milk. Human milk contains less phenylalanine than baby milk formula so that more mother's milk and less low-phenylalanine formula is required to control the infant's blood phenylalanine concentrations. Mothers are encouraged to continue breast-feeding on demand but prior to 3 or 4 of the breast-feeds, low-phenylalanine formula 15–20 ml/kg (i.e. 60 ml/kg per day) is given. The volumes of low-phenylalanine formula given are adjusted to maintain a blood phenylalanine concentration of 120–360  $\mu\text{mol/L}$  (2–6 mg/100 ml).

Mixed feeding should be introduced between 4 and 6 months. Infants who are not breast-fed should initially have solids containing negligible amounts of phenylalanine, e.g. strained vegetables and fruit, or manufactured baby foods known to have very low-phenylalanine content. Breast-fed infants should be introduced to solids, which contain some phenylalanine. Initially 50 mg phenylalanine should be given, e.g. one Farley's rusk or specific quantities of baby foods known to contain 50 mg phenylalanine. Close and relatively frequent monitoring of the blood phenylalanine levels is necessary at this stage to ensure a correct balance between the amounts of phenylalanine received from solid food and the amount received from breast-milk.

Between the ages of 9 and 12 months a gradual change over from low phenylalanine milks to one of the amino acid mixtures can be given. We have adopted a diet which is easy to prepare and reasonably acceptable to the child. The parents of young children starting solid food are given food tables indicating the weight of individual foodstuffs, which contain 50 mg phenylalanine (L-phenylalanine exchange). The number of exchanges required will be determined by regular measurements of the child's blood phenylalanine levels. By this means the child's food preferences can best be catered for. Many fruits and vegetables can be given without restriction though some, e.g. peas, beans, potatoes, must be accounted for.

On this diet a child can sit down to a meal which, apart from the lack of meat and other protein, looks very like that of the rest of the family. PKU children can be taken to hotels and holiday camps, and we have experienced no difficulty in arranging for schools to provide the special diet. Indeed, we have been told that sometimes the child's classmates envy them their special diet.

The dietary treatment of PKU has been considered in some detail because the same principles are applicable in several of the other IEM, which involve the essential amino acids. It will be obvious to the reader that the adequate treatment of the IEM requires that such patients attend special centres with the necessary dietetic and laboratory facilities. Children with PKU vary greatly in their tolerance to phenylalanine and the frequency of blood testing will need to be more in some than in others. In general, we test blood phenylalanine concentration weekly up to the age of 4 years, every 2 weeks thereafter up to the age of 10 years and thereafter monthly. The parents require constant guidance and support particularly from the dietitian. The intelligence and completely commitment of the parents are primary determinants of the child's intellectual development. There are as yet no clear guidelines to indicate whether the special diet can be stopped. At the present time, we recommend that the diet should be continued for life.

Although treated individuals may achieve a high academic status, there can be subtle global impairment determined by the degree of control in the early years of treatment. Magnetic resonance imaging (MRI) reveals abnormal myelin structure in most adolescents and adults with phenylalanine concentrations greater than 400  $\mu\text{mol/L}$ . Overt neurological deterioration is found in some. It is now evident that we must aim for very strict control in earlier life, promote a policy of lifetime treatment and ensure a strict preconception diet in women likely to conceive. Effective and safe gene therapy may be a reality in the not too distant future.

## OTHER DISTURBANCES OF AMINO ACID METABOLISM

### Hypertyrosinaemia

*Hereditary tyrosinaemia type 1 (hepatorenal tyrosinaemia)* is due to a deficiency of the enzyme fumarylacetoacetase hydrolase. It presents acutely in the newborn infant with failure to thrive, vomiting, diarrhoea, hepatomegaly and bleeding disorder with bruising, haematemesis, melaena and haematuria; death from haemorrhage and liver failure is common. Plasma and urinary concentrations of tyrosine and methionine are increased. Patients with a more chronic form may occur within the same family and have in addition to liver disease, renal tubular dysfunction, hypophosphataemia and rickets. In later life, hepatoma develops in more than half of those surviving the first year and many develop hepatic cirrhosis and episodes of severe acute peripheral neuropathy.

*Tyrosinaemia type 2 (oculocutaneous tyrosinaemia)* is due to a deficiency of tyrosine aminotransferase. Eyes, skin and central nervous system (CNS) are the only organs known to be affected in tyrosinaemia type 2. It is characterised by lacrimation, photophobia with tyrosine crystals in the cornea and with associated dendritic keratitis and ulcers. Keratitis also affects the skin.

Treatment with NTBC (2-(2-nitro-4 trifluoromethylbenzoyl)-1,3-cyclohexanedione) was introduced in 1992 for tyrosinaemia type 1 and has revolutionised the outlook. NTBC blocks tyrosine degradation inhibiting 4-OH phenylpyruvate dioxygenase—an earlier step in tyrosine metabolism. Due to the consequent build up of tyrosine levels (which can give rise to features akin to tyrosinaemia type 2), a low-phenylalanine and tyrosine diet is required. The risk of hepatocellular carcinoma is much reduced.

### Alkaptonuria

Alkaptonuria is due to deficiency of the enzyme homogentisic acid oxidase so that homogentisic acid, instead of being converted to maleylacetoacetate, accumulates in the tissues and is excreted in the urine. The urine is noted to turn dark on standing as the homogentisic acid is oxidised to a melanin-like product (or it can be made to do so immediately by the addition of ammonia or sodium hydroxide). The alkaptonuric is symptomless in childhood but in adult life develops ochronosis and arthritis. This causes an ochre-like pigmentation of sclerae, ears, nasal cartilages and tendon sheaths, also kyphosis and osteoarthritis of the large joints. Although the inheritance is usually autosomal recessive, a few families have shown dominant inheritance. There is no specific treatment.

## DISORDER OF BRANCHED-CHAIN AMINO ACID METABOLISM

### Maple Syrup Urine Disease

In maple syrup urine disease, so-called because the urine from affected infants has an odour (sweet, malty, caramel-like) of maple syrup or burnt sugar, neurological disturbances appear soon after birth, e.g. difficulties with feeding, absence of the Moro reflex, irregular respirations, spasticity and opisthotonus; mild hyperammonaemia may also be present. Pronounced dehydration and metabolic acidosis are not usual features of acute MSUD, in contrast to disorders of organic acid metabolism. Early diagnosis and management are essential to prevent permanent brain damage or death. The ferric chloride test on the urine gives a green colour, which could be mistaken for phenylpyruvic acid. Urine chromatography will reveal abnormally high concentrations of the branched-chain amino acids valine, leucine and isoleucine and their corresponding keto-acids.

#### Treatment and Prognosis

Very high blood and tissue levels of branched-chain amino acids in the acutely ill newborn will require urgent treatment in the form of haemodialysis, peritoneal dialysis or exchange transfusions to reduce plasma levels of toxic metabolites. Long-term treatment by a lifelong diet low in the 3-branched-chain amino acids has been successful in preventing the manifestations of this disease when diagnosis was made very soon after birth. Supplementation with an amino acid mixture lacking the branched-chain amino acids is necessary in a protein-restricted diet. The long-term outcome depends on early diagnosis and management.

### Organic Acidaemias

There are now described more than thirty inherited conditions characterised by an excessive urinary excretion of acidic metabolites of amino acids, carbohydrates and fats. Infants with otherwise unexplained metabolic acidosis, who become acutely ill, should have plasma and urine levels of a specific organic acid and its by-products analysed by gas chromatography-mass spectrometry (GC-MS) in order to detect conditions such as 3-methylcrotonyl glycinuria, IVA, glutaric aciduria, propionic aciduria and methylmalonic aciduria. Of these, propionic and methylmalonic aciduria constitute the most commonly encountered abnormal organic acidurias in children.

Infants with isovaleric, propionic and methylmalonic acidurias have many symptoms in common. Babies after an initial symptom-free period may present with feeding difficulties, vomiting, lethargy, respiratory distress,

hypotonia and generalised hypertonic episodes. Metabolic acidosis, ketonuria, hyperammonaemia, hypocarnitinaemia, neutropenia and thrombocytopenia are almost constant findings. The acute presentation is frequently precipitated by infection or some other form of stress. Treatment includes stopping all protein intake and maintenance with dextrose and bicarbonate to control acidosis. The emergency treatment of organic acidurias consists of removal of toxins by haemo or peritoneal dialysis and/or exchange transfusions. The use of N-carbamyl glutamate 100 mg 6 hourly acutely has revolutionised the correction of hyperammonaemia by replacing the absent promoter of carbamoyl phosphate synthetase. In addition, glycine in isovaleric, biotin in propionic and vitamin B<sub>12</sub> in methylmalonic acidurias should be given. L-carnitine (125 mg/kg per day) should be given to patients with all three disorders. The long-term treatment involves reducing accumulated toxic products, maintaining normal nutritional status and preventing catabolism. Therefore, in these children protein intake is largely restricted.

## UREA CYCLE DISORDERS

Five well-documented diseases have been described, each representing a defect in the biosynthesis of one of the normally expressed enzymes of the urea cycle, which converts nitrogen in amino acids into urea and CO<sub>2</sub> (Fig. 20.2). Carbamyl phosphate synthetase converts ammonia and bicarbonate to carbamyl phosphate, which then condenses with ornithine under the action of ornithine transcarbamylase to form citrulline. The conversion of citrulline to argininosuccinic acid is catalysed by argininosuccinate synthetase, and

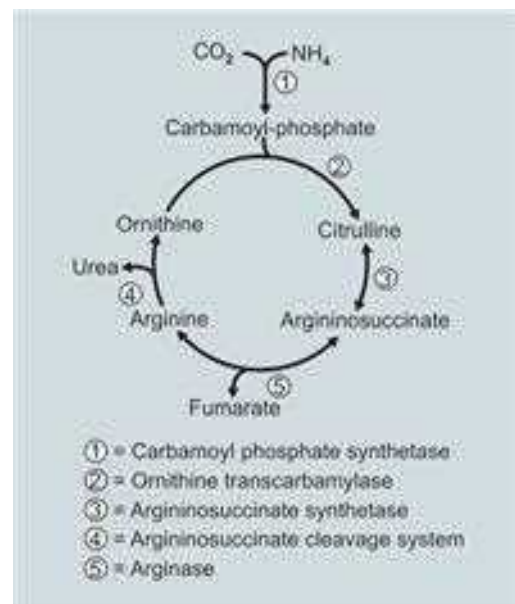


Fig. 20.2: The ornithine-urea cycle



argininosuccinic acid is cleaved to form arginine and fumaric acid by argininosuccinate cleavage enzyme (argininosuccinase). The enzyme arginase finally converts arginine into urea and ornithine. The synthetic process takes place in the liver. The mechanisms leading to the toxicity of ammonia are not fully understood. The clinical manifestations of urea cycle disorders are mainly abnormalities secondary to hyperammonaemia and protein intolerance. A rapid diagnosis and institution of diet is essential for a good prognosis.

All enzyme defects have autosomal recessive inheritance, except for ornithine transcarbamylase, which is inherited as an X-linked trait with variable expression in the female. The increased amounts of orotic acid indicates carbamoyl phosphate was synthesised and along with the plasma amino acid pattern indicates the specific disorder. In suspected cases the institution of a high-carbohydrate, protein-free diet may produce a dramatic improvement after a few days. Long-term treatment is with a low-protein diet but the condition shows a variable clinical expression in age of onset and severity of symptoms. Even with early institution of a low-protein diet and prompt treatment of metabolic crises, prognosis for normal development is guarded.

### Argininaemia

Argininaemia presents in childhood with hyperammonaemia, vomiting and retarded development with spastic quadriplegia, convulsions and hepatomegaly. Plasma and cerebrospinal fluid (CSF) arginine concentrations are grossly elevated and the urine contains excessive quantities of cystine, lysine, ornithine, arginine and citrulline. Arginase deficiency can be demonstrated in erythrocytes and is rare (1 in 500,000).

## DISORDERS OF THE SULPHUR-CONTAINING AMINO ACIDS

### Homocystinuria

Homocystinuria is a rare defect of the sulphur-containing amino acids (1 in 350,000). Inheritance is autosomal recessive, and the defect is in cystathionine  $\beta$ -synthetase. This enzyme catalyses the condensation of homocysteine (derived from methionine) with serine to form cystathionine. This enzyme block results in accumulation of homocysteine in blood and tissues, and its excretion in the urine in its oxidised form, homocystine (dimer). There will also be raised blood levels of methionine; cystathionine levels in the brain are grossly reduced. Usually the four systems involved are the eye, the skeleton, the CNS and the vascular system. The fully developed clinical picture includes mental retardation, seizures, malar flush, fair hair, downward dislocation of the lens, livido reticularis and thromboembolic episodes in both arteries and veins. Skeletal changes are also common, e.g.

genu valgum, pes cavus, arachnodactyly, irregular epiphyses, vertebral changes, osteoporosis and pectus carinatum or excavatum. The fully developed picture resembles that of Marfan's syndrome (Marfanoid habitus of the body) but in the latter there is no mental retardation, osteoporosis or thrombotic tendency and the dislocation of the lens is upwards; inheritance in Marfan's is autosomal dominant. A significant proportion of patients with homocystinuria develop a normal level of intelligence. The diagnosis can be made early in infancy during screening programmes particularly of the non-pyridoxine responsive form, and before clinical abnormalities have become manifest. When suspected in the older patient, the nitroprusside/cyanide test may be used to screen the urine. However, this cannot discriminate between an excess of cystine or homocystine in the urine. A positive reaction is an indication for chromatographic examination of blood and urine for increased concentrations of homocysteine or methionine. When treatment is started in the neonatal period with a diet low in methionine, along with cystine supplements, normal development may be expected. Suitable amino acid mixtures with added cystine are now commercially available. Monitoring of treatment requires assessing total homocysteine in the blood. Worldwide, there are two distinct types of homocystinuria: about 50% of cases respond completely to treatment with pyridoxine (vitamin B6) 150–450 mg/day used as single-agent therapy, but the other half remain unresponsive. The treatment is more successful when the diagnosis is made early.

## DISORDERS OF SPECIFIC SUGARS

### PATHOGENESIS

Galactose is ingested as lactose in milk, which undergoes splitting in the intestine into its component monosaccharides glucose and galactose. Milk and its products are virtually the sole source of dietary galactose in man. Galactose is then converted to glucose or energy in a series of enzyme steps (Fig. 20.3). Although the liver is the main site of this conversion, the demonstration of a similar series of enzyme reactions in red cells and the excess accumulation of galactose-1-phosphate (Gal-1-P) in the erythrocytes from galactosaemic patients made it likely that the defect lay in the activity of Gal-1-P uridyl transferase and in the inability to convert Gal-1-P to glucose-1-phosphate (step 2 in Fig. 20.3). The accumulation in the erythrocytes of Gal-1-P, believed to be the major toxic substance in galactosaemia is evidence that galactokinase activity is normal. In fact, galactosaemic red cells have been confirmed to be defective in Gal-1-P uridyl transferase and a similar deficiency has been demonstrated in liver tissue from affected patients. Gal-1-P uridyl transferase is absent in all tissues and the enzyme deficiency persists throughout life.

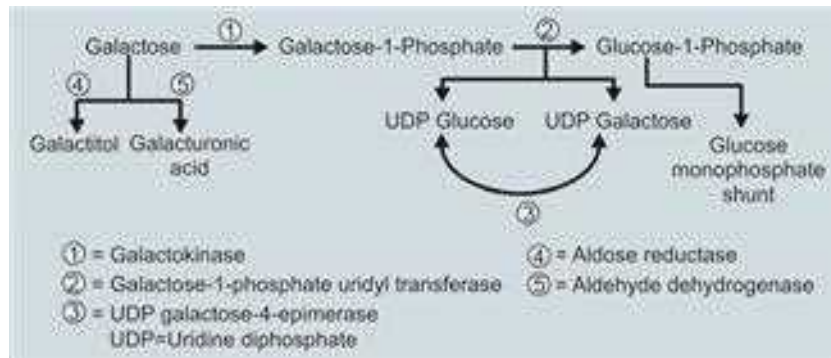


Fig. 20.3: Enzyme steps in galactose metabolism in erythrocytes

## CLINICAL FEATURES

Two main clinical types occur. The more severely affected children develop clinical features within 2 weeks of birth, after milk-feeding has been started, with vomiting, disinclination to feed, diarrhoea, loss of weight, dehydration, hypoglycaemia, hepatocellular damage and renal tubular damage. The liver is enlarged with a firm, smooth edge and there may be jaundice. Splenomegaly is common. Cataracts may be seen with a slit-lamp. Finally, the infant becomes severely marasmic with hepatic cirrhosis, ascites and hypoprothrombinaemia. Obvious signs and symptoms are later to appear in the less severe type, although a history suggesting some early intolerance to milk may be obtained. The child may present with mental retardation, bilateral cataracts and cirrhosis of the liver. All the abnormalities, except for mental retardation, may regress rapidly on a galactose-free diet. It is, therefore, of prime importance that the diagnosis is made before irreversible brain damage has occurred. Undiagnosed cases may succumb to gram-negative sepsis.

## DIAGNOSIS

The first clue to the disease may be a positive Benedict's test for the presence of a reducing substance in the urine. However, care must be taken as due to developing tubulopathy, specific test for urine glucose (Clinistix, which uses the enzyme glucose oxidase) may be positive; proteinuria may also be present. Chromatography is required to confirm the reducing substance as galactose. There may be a marked aminoaciduria due to renal tubular damage. Galactitol can be detected in blood and urine. A valuable diagnostic test, which can be used for umbilical cord blood testing in the infant born into a known galactosaemic family and before milk feeds have started, is the demonstration of the absence of Gal-1-P uridyl transferase activity in the red cells. An alternative test for use in the newborn is based on the excess accumulation of Gal-1-P in the erythrocytes in this disease. It

is possible to "screen" for galactosaemia during the neonatal period by a modified Guthrie test or chromatography of heel-stab blood and to start treatment before clinical features have appeared.

## TREATMENT

The infant should be placed on a diet that is free of milk and all milk products. In families with known affected siblings, the diagnosis can and should be confirmed before the infant receives its first milk feed. Suitable milk substitutes, which are almost free from lactose, are galactomin 17 (Cow and Gate) and Nutramigen and Pregestimil (Bristol-Myers) or any of the proprietary soya-based baby milks, e.g. Formula "S" (Cow and Gate), Prosobee (Bristol-Myers) and Wysoy (Wyeth). Supplementary vitamins and minerals must be given if galactomin 17 is used. Dietary restriction should be fairly strict during the first 2 years and probably there should be some lifelong restriction of milk and milk products intake. Unfortunately, galactosaemic children tend to fall below the average in mental development in spite of dietary treatment, although they remain within the educable range and have good physical health. As adolescents, some develop educational difficulties, memory loss and abnormal neurological findings including ataxia, incoordination and brisk reflexes. Young women usually develop infertility. Therefore, a guarded prognosis should be given to parents of newly diagnosed cases.

### Galactokinase Deficiency

An elevated blood galactose level may also result from a deficiency of the enzyme galactokinase by which galactose is phosphorylated to Gal-1-P (Fig. 20.3). Galactokinase deficiency is associated with galactosuria, but the only significant pathology is the development of cataracts, which may be nuclear or zonular and is due to accumulation of galactitol in the lens. Liver, renal and brain damage do not occur. The dietary treatment as for galactosaemia prevents

the development of cataracts and should be started as early in infancy as possible.

### Epimerase Deficiency

Deficiency of epimerase enzyme may produce a clinical picture similar to that of Gal-1-P uridyl transferase defect or may be asymptomatic. Symptomatic patients also respond to milk-free diets. It is rare, representing less than 3% of galactosaemic children.

### Hereditary Fructose Intolerance

#### Aetiology

This disease causes severe metabolic disturbances and it is inherited as an autosomal recessive trait. It must be clearly distinguished from benign fructosuria which is due to a deficiency of fructokinase and which produces no clinical disease.

#### Pathogenesis

The metabolic pathways of fructose are complicated. The primary enzymatic defect is in fructose-1-phosphate aldolase, which in the liver and intestine splits fructose-1-phosphate into two trioses, (1) glyceraldehyde and (2) dihydroxyacetone phosphate. This defect results in the accumulation of fructose-1-phosphate, which inhibits fructokinase and leads to high blood levels of fructose after its ingestion in the diet. The intracellular accumulation of fructose-1-phosphate prevents the conversion of liver glycogen to glucose.

#### Clinical Features

Symptoms only appear when fructose is introduced into the diet as sucrose (glucose + fructose) in milk feeds, as sorbitol or as fruit juices. The condition varies in severity, partly according to the amounts of fructose ingested, and the wholly breast-fed infants remain symptomless. Common features are failure to thrive, anorexia, vomiting, diarrhoea and hepatomegaly; these may lead to marasmus. Hypoglycaemia may cause convulsions or loss of consciousness. Liver damage may result in jaundice, and liver function tests are abnormal. Albuminuria, fructosuria and excess aminoaciduria may be present. Hyperfructosaemia and hypoglycaemia develop following upon the ingestion of fructose or sucrose. Death ensues in undiagnosed infants. In milder cases in older children gastrointestinal symptoms predominate, and in some a profound distaste of anything sweet develops spontaneously as a protective mechanism.

#### Diagnosis

The diagnosis is usually suspected due to its clinical presentation, by a dietary history and by a favourable

response to removal of fructose from the diet. An oral fructose tolerance test (1 g/kg up to a maximum of 50 g) results in a marked and prolonged fall in the blood glucose level and a fall in the inorganic phosphorus but is potentially very dangerous. Thus, removal of fructose from the diet and genetic testing is now the preferred approach.

#### Treatment

The treatment consists simply in the lifelong removal of all fructose-containing foods from the diet and of sucrose from the milk feeds. Sorbitol, a fructose polymer, must not be used as a sweetening agent. An incidental benefit of the sucrose-free diet is a marked reduction in the incidence of dental decay.

### Hereditary Fructose-1,6-Bisphosphatase Deficiency

Although not a defect of the specialised fructose pathway, hepatic fructose-1,6-bisphosphatase deficiency is usually classified as an error of fructose metabolism. It manifests with spells of hyperventilation, apnoea, hypoglycaemia, ketosis and lactic acidosis and may be life-threatening in the newborn period.

## DISORDERS OF PURINE AND PYRIMIDINE METABOLISM

Inherited disorders of purine and pyrimidine metabolism are rare.

*Hereditary orotic aciduria* is an autosomal recessive condition in which there is failure to thrive, hypochromic anaemia with megaloblasts in the bone marrow, and increased urinary excretion of orotic acid. The underlying enzyme defect may involve one or both of the enzymes concerned in the synthesis of uridine monophosphate, orotate phosphoribosyltransferase and orotidylate decarboxylase. Treatment with uridine, 1 g per day, results in correction of the anaemia and impaired growth.

*Lesch-Nyhan syndrome* is an X-linked recessive disorder in which male infants are generally normal at birth. It is characterised by CNS disorders of various types and excessive quantities of uric acid in blood, tissue and urine. The disorder is caused by deficiencies of the enzyme hypoxanthine-guanine phosphoribosyltransferase (HGPRT). Affected boys can be severely mentally retarded and have choreoathetosis, spasticity and distressing compulsive self-mutilation or they may present with gouty arthritis or ureteric colic caused by urate stones. A definite diagnosis of the Lesch-Nyhan syndrome can be made by the absence of HGPRT activity in the peripheral circulating erythrocytes. Allopurinol and probenecid will reduce the hyperuricaemia but has little effect on the neurological dysfunction.

## CONGENITAL METHAEMOGLOBINAEMIA

### AETIOLOGY

The most common form of congenital methaemoglobinaemia is inherited as an autosomal recessive trait and it is due to the absence of a normal intraerythrocytic enzyme activity. A rare type, inherited as an autosomal dominant, has a quite different aetiology in that it is due to the formation of haemoglobin M with a defective globulin component.

### PATHOGENESIS

In normal haemoglobin, the iron of the four-haem groups is in the reduced or ferrous state. In methaemoglobin, the iron is in the oxidised or ferric state and it is incapable of combining with oxygen. In normal erythrocytes, methaemoglobin is constantly being formed and in normal blood, a small amount is always present. It is, however, continuously being reduced back to haemoglobin by a complex series of enzyme steps. In congenital methaemoglobinaemia, there is an intraerythrocytic defect in one of these enzyme reactions. The other form of congenital methaemoglobinaemia belongs to the haemoglobinopathies and haemoglobin M can be separated from HbA by electrophoretic techniques.

### CLINICAL FEATURES

The primary sign is a dusky slate-grey type of cyanosis, which is present from birth. The child is free from respiratory or cardiac symptoms and clubbing of the fingers and toes does not develop. Some patients develop compensatory polycythaemia and some may go on to become severely mentally retarded.

### DIAGNOSIS

The presence of excess methaemoglobin in the blood should be demonstrated by spectrophotometry.

It is important to distinguish the congenital and permanent form of methaemoglobinaemia from the temporary but dangerous acquired form, due to toxins such as aniline dyes, nitrites, acetanilid and potassium chlorate. Outbreaks of acquired methaemoglobinaemia have occurred in newborn nurseries when new napkins marked by aniline dyes have been used before laundering and cases have occurred in children drinking well-water containing nitrites. Therefore, assays of methaemoglobin reductase and detection of haemoglobin M are essential to confirm the specific diagnosis. It is also important to remember that cyanotic children without heart murmurs may have methaemoglobinaemia. Anecdotally, in our experience an erroneous diagnosis of congenital heart disease has been made in two such cases and one child was unnecessarily submitted to cardiac catheterisation.

### TREATMENT

Methaemoglobinaemia due to the deficiency of enzyme methaemoglobin reductase may respond to ascorbic acid 200–500 mg/day or methylene blue 5 mg/kg per day, given orally or intravenously. These drugs do not, however, have any beneficial effect in haemoglobin M disease.

### GLYCOGEN STORAGE DISORDERS

Glycogen is a complex high molecular weight branched polysaccharide composed of numerous glucosyl units linked together. It is mainly found in the liver and muscle. The glucosyl units are mainly linked together through carbon atoms 1 and 4 but at the branch points the bonds are between C1 and C6. Multiple enzymes are involved in the synthesis (glycogenesis) and breakdown (glycogenolysis) of glycogen. In health, human liver glycogen content varies from 0% to 5%, while muscle glycogen is rarely as high as 1%. Hepatic glycogen functions as a reserve of glucose and is utilised during fasting to maintain normoglycaemia.

#### Glycogenesis

Glucose reacts with ATP under the catalytic activity of hexokinase to form glucose-6-phosphate and ADP. Glucose-6-phosphate is then converted to glucose-1-phosphate by phosphoglucomutase. The next step is the conversion of glucose-1-phosphate to glucosyl units in 1,4-linkage. While this can be achieved in vitro by phosphorylase, it is possible that in vivo it proceeds independently of phosphorylase and by means of two other steps involving: (1) uridine diphosphate glucose (UDP)-pyrophosphorylase and (2) uridine diphosphoglucose (UDPG)-glycogen transglucosylase. This may explain the apparent paradox that the activation of phosphorylase in vivo always leads to glycogen breakdown and never to glycogen synthesis. When a chain of the growing glycogen molecule reaches a critical level a branch point is established by transfer of the 1,4-linkage to a 1,6-linkage, this being mediated by amylo-(1,4-1,6)-transglucosidase (brancher enzyme).

#### Glycogenolysis

Glycogen can be converted back to glucose-1-phosphate by the enzymes phosphorylase, which breaks the 1,4-linkage, and amylo-1,6-glucosidase (debrancher enzyme) which breaks the 1,6-linkage. Glucose-1-phosphate is then converted to glucose-6-phosphate, a reversible reaction, by phosphoglucomutase. Finally, glucose-6-phosphate can be converted to free available glucose by glucose-6-phosphatase. This enzyme is found only in the liver and kidneys. Glycogen in the muscles cannot be converted to free glucose but only to pyruvate and lactate via the Embden-Meyerhof glycolytic pathway.

Glycogen storage disorders comprise a group of disorders, some of which have hepatic presentations with liver enlargement and hypoglycaemia. In addition, there are a number of subtypes with exercise-induced myalgia and cramps often leading to rhabdomyolysis. Two of these (myopathic GSD III and GSD IV) give rise to a chronic myopathy affecting trunk, limb and respiratory muscles. GSD II (Pompe's disease) is a specific defect affecting lysosomal breakdown of glycogen presenting with cardiomyopathy in infancy.

### Type I Glycogenosis (von Gierke Disease; Glucose-6-Phosphatase Deficiency)

#### Aetiology

This was the first of the glycogenoses to be recognised. It is inherited as an autosomal recessive disorder. The heterozygous, and apparently healthy, carriers of the gene can be detected by the lowered glucose-6-phosphatase level in the intestinal mucosa.

#### Pathogenesis

The enzyme glucose-6-phosphatase normally liberates free glucose from glucose-6-phosphate in the liver. Its absent activity results in GSD type Ia.

#### Clinical Features

Gross enlargement of the liver is the most constant feature and it is often recognised in early infancy. In the severe form, it may present in the neonatal period with profound hypoglycaemia and acidosis. Growth is stunted and the protuberant abdomen is often associated with an exaggerated lumbar lordosis. Genu valgum (knock knees) is common. There may be an excess deposition of subcutaneous fat, leading to affected infants developing a characteristically round (doll-like) face (Fig. 20.4). Xanthomatous deposits are commonly found on the knees, elbows and buttocks. There is no splenomegaly and there are no signs of cirrhosis. Gout and uric acid nephropathy may develop and there are reports of hepatic adenomata formation. The presence of fever may lead to an erroneous diagnosis of sepsis.

Type Ib has a similar clinical course with the additional findings of neutropenia and impaired neutrophil function resulting in recurrent bacterial infections. Oral and intestinal mucosa ulceration commonly occurs.

#### Biochemical Findings

Ketonuria is common in the fasting state. Hypoglycaemia may be so severe as to precipitate convulsions and even lead to mental impairment. Hyperlipaemia and hypercholesterolaemia are marked and may even interfere with accurate measurement



**Fig. 20.4:** Four-month infant with glycogen storage disease type Ia. Note rounded facies and gross hepatomegaly

of plasma electrolytes. Episodes of severe metabolic acidosis develop in some cases. Plasma pyruvate and lactate concentrations are increased and phosphate may be reduced. Renal damage from glycogenosis can cause glycosuria and aminoaciduria.

#### Diagnosis

Hepatomegaly with the combination of hypoglycaemia, hyperlactic acidemia and hyperuricaemia is virtually diagnostic of type I glycogenosis. Further evidence of von Gierke disease may be obtained from a variety of tests.

- The glucose tolerance test (after 1.5 g glucose/kg) shows paradoxical fall in plasma lactate.
- Another indirect measurement of glucose-6-phosphatase activity can be obtained after an intravenous dose of galactose 1 g/kg, or fructose 0.5 g/kg. Blood glucose concentrations at 10-minute intervals are compared with the pre-injection value. In healthy persons, galactose and fructose are converted via glucose-6-phosphate to free glucose, but this metabolic pathway is blocked in von Gierke disease.

Conclusive proof of the diagnosis, however, can only be obtained from a liver biopsy for low glucose-6-phosphatase activity or DNA mutation analysis in blood.

#### Treatment

Although the enzyme failure cannot be corrected, considerable benefit can accrue from a diet in which a high intake of carbohydrate is given in frequent feeds throughout the 24 hours. Where hypoglycaemia occurs in the early hours

of the morning overnight continuous intragastric feeding can produce remarkable clinical benefit. Use of slowly digested carbohydrate such as cornflour can help to maintain blood glucose concentration. Episodes of severe metabolic acidosis, often precipitated by intercurrent infections, can endanger life. They must be promptly treated with intravenous glucose and sodium bicarbonate under careful biochemical control. Diazoxide may be of help in infants with intractable hypoglycaemia. Portocaval anastomosis, which acts by diverting glucose from the liver to the tissues, may be of help. Liver transplantation has been performed in GSD type I but should be performed only after all other methods of treatment have failed or if there has been malignant transformation of adenoma. If these children can be tided over the dangerous early years their health often improves greatly during adolescence.

### **Glycogenosis of the Heart (Cardiomegalia Glycogenica; Idiopathic Generalised Glycogenosis; Pompe's Disease; Type II)**

#### *Aetiology*

Autosomal recessive inheritance.

#### *Pathogenesis*

The disease may involve the CNS and skeletal muscles as well as the myocardium. It has been shown that the primary defect is of the lysosomal enzyme acid  $\alpha$ -1,4-glucosidase (acid maltase). In biopsy specimens, spontaneous glycogenolysis is rapid and glycogen does not show the abnormal stability, which is a characteristic finding in the other types of glycogenoses.

#### *Clinical Features*

Clinically, the enzyme deficiency results in two major presentations. The first was originally described by Pompe. The infant becomes ill in the early weeks of life with anorexia, vomiting, dyspnoea and failure to thrive. The heart is enlarged, tachycardia is present, and a systolic murmur is commonly heard. Oedema may also develop. The ECG shows a shortened P-R interval, inverted T waves and depression of the ST segments. When skeletal muscles are severely involved the degree of hypotonia may simulate Werdnig-Hoffmann disease. In some infants, macroglossia has been so-marked as to arouse the suspicion of cretinism. On the other hand, hepatomegaly is not prominent until cardiac failure is advanced. The diagnosis may be established by muscle biopsy and the demonstration of increased glycogen content. There will also be low acid maltase activity in the leucocytes.

The second presentation is of a more slowly progressive muscle disorder, with symptoms beginning in childhood or in

adult life and manifestations limited to skeletal muscle. The muscle involvement is mainly proximal muscle weakness including impairment of respiratory function. Death results from respiratory failure.

#### *Treatment*

Enzyme replacement therapy (ERT) therapy appears to stabilise the clinical symptoms in the later onset and if instituted early improves the scenario in neonatal onset.

### **Type III Glycogenosis (Limit Dextrinosis; Debrancher Enzyme Deficiency)**

#### *Aetiology*

It is autosomal recessive.

#### *Pathogenesis*

The debrancher enzyme (amylo-1,6-glucosidase) is absent from liver, skeletal and cardiac muscle, resulting in glycogen deposition in these organs (unlike von Gierke's disease, where glycogen deposition does not occur in heart and skeletal muscles).

#### *Clinical Features*

Hepatomegaly is marked but hypoglycaemic problems are less troublesome and there is less interference with growth. It is common to find the same plump appearance and round face as in von Gierke disease (Fig. 20.4). In some cases, the involvement of skeletal muscles gives rise to weakness and hypotonia.

#### *Diagnosis*

Ketonuria may appear during fasting. De-esterification of glucose-6-phosphate to glucose can proceed normally and there is, therefore, a normal hyperglycaemic response to intravenous galactose or fructose. The serum lactate level is not often raised but rises during an oral glucose tolerance test (OGTT); there is dyslipidaemia. The liver glycogen content is increased and it is abnormal in structure with short external chains and an increased number of 1,6 branch points. Activity of liver amylo-1,6-glucosidase is not detectable. It is also possible to demonstrate an elevated erythrocyte glycogen of the limit dextrin type. Direct assay of the enzyme in liver and muscle tissue is confirmatory.

#### *Treatment*

Frequent feedings with a high-carbohydrate, high-protein diet and overnight nasogastric feedings can be very beneficial. Cardiac involvement is rarely clinically demonstrable but strenuous exercise should probably be avoided. No specific treatment is available for this disorder.

### **Type IV Glycogenosis (Familial Cirrhosis of the Liver with Abnormal Glycogen; Amylopectinosis; Brancher Enzyme Deficiency)**

This appears to be an extremely rare disease in which amylo-(1,4-1,6)-transglucosidase deficiency results in deposition of an abnormal glycogen with a molecular structure resembling the amylopectins of plants. This substance is toxic so that the patient presents with cirrhosis of the liver, splenomegaly and jaundice. Liver function tests yield grossly abnormal results and death is preceded by the development of ascites and deep jaundice. This diagnosis should be considered in all cases of familial hepatic cirrhosis. Deficiency of the branching enzyme can be demonstrated in liver and leucocytes. There is no specific treatment for GSD type IV.

### **Type V Glycogenosis (Myophosphorylase Deficiency; McArdle Disease)**

Children with myophosphorylase deficiency are asymptomatic at rest but muscle cramps occur with moderate exercise. These symptoms are usually absent or minimal during the first decade. A diagnosis is made on the basis of history and the absence of elevation of lactate after exercise. It may remain undiagnosed during childhood and presents in adult life with muscle weakness, cramps and a characteristic 'second-wind' phenomenon. In the absence of severe exercise, the patients remain asymptomatic.

No specific treatment is available, but the patient should continue regular exercise such as walking to keep fit.

## **INBORN ERRORS OF LIPID METABOLISM (THE LIPOSES)**

This group includes Gaucher disease, Niemann-Pick disease, Tay-Sachs disease, metachromatic leukodystrophy and Krabbe's leukodystrophy. In the lipidoses, there is an abnormal intracellular deposition of sphingolipids, often widely spread throughout many organs and tissues as in Gaucher and Niemann-Pick diseases.

### **Gaucher Disease**

#### *Aetiology*

In Gaucher disease, a glucocerebroside (glucosylceramide) is deposited in the tissues. The glycolipids, which go to form glucocerebroside, are derived from senescent leucocytes and erythrocytes. They are normally broken down by a series of enzymes, one of which is glucocerebroside. In the type 1 form of the disease the spleen has only about 15% of normal enzyme activity whereas in the type 2 acute form glucocerebroside is completely absent from the spleen and other organs (including the brain).

#### *Clinical Features*

This disease appears to occur in three forms: (1) Type 1 adult, chronic, non-neuropathic form, (2) Type 2 infantile, acute, neuropathic form and (3) Type 3 juvenile sub-acute neuropathic form. All are inherited autosomal recessively. Gaucher type 1 disease is particularly common in Jewish families.

*Type 1 Gaucher disease:* The type 1 chronic form is the most common. It presents at any age from a few months to late adulthood with gross splenomegaly. Hepatic enlargement may also be marked. There is also a progressive anaemia, and leucopenia and thrombocytopenia due to hypersplenism developing early in its course. Bone involvement may give rise to limb pains. Radiographs reveal a characteristic flaring outwards of the metaphyseal ends of the long bones with thinning of the cortex. This is most marked at the lower ends of the femora, which have an Erlenmeyer flask appearance. These features develop in childhood or early adult life. In older patients especially, the face, neck, hands and legs may show a characteristic brownish pigmentation, and the conjunctiva may show a wedge-shaped area of thickening with its base to the cornea (pinguecula). The diagnosis can be confirmed by finding the lipid-filled cells, which have a typical fibrillary appearance of the cytoplasm. These should be sought in material obtained by needle puncture of the bone marrow, spleen or lymph nodes. The disease runs a slow course but death is inevitable.

*Type 2 Gaucher disease:* The type 2 infantile acute form is a rare presentation confined to infancy. In addition to hepatosplenomegaly, there is evidence of severe cerebral involvement, which is rarely seen, in the chronic form. There may be hypertonia, catatonia, trismus, opisthotonus, dysphagia, strabismus and respiratory difficulties. Death occurs by the age of 3 years.

*Type 3 Gaucher disease:* The type 3 juvenile sub-acute form shares some characteristics of types 1 and 2. Neurological features may appear early in addition to hepatosplenomegaly but the time course of progression is slower. Spasticity, ataxia, ocular palsies, mental retardation and seizures are later features. Ultimate proof of diagnosis requires tissue or white blood cell betaglucosidase (glucocerebroside) assay, or liver or spleen glucocerebroside determination. Prenatal diagnosis is routinely available for all types of Gaucher disease.

#### *Treatment*

Treatment is now available with synthetic enzyme replacement and bone marrow transplantation. Splenectomy is indicated when splenomegaly is massive and interferes with normal growth and development.

## Niemann-Pick Disease

### Aetiology

Sphingomyelin, a component of myelin and other cell membranes, accumulates within cells throughout the CNS and other tissues. Sphingomyelin is normally catabolised by the action of sphingomyelinase but in Niemann-Pick disease type A or B this enzyme activity is only about 7% of normal. In type C, there is a complex defect in cellular cholesterol trafficking.

### Clinical Features

This disease also consists of a group of disorders characterised by hepatosplenomegaly and accumulation of sphingomyelin (ceramide phosphorylcholine) in organs and tissues. Three clinical forms have been identified. In type A (acute neuropathic), which is the commonest, there is hepatosplenomegaly by 6 months of age and there are severe feeding difficulties related to CNS involvement. It is inherited in an autosomal recessive fashion. The infant's abdomen becomes greatly protuberant due to massive hepatosplenomegaly. Skin pigmentation is common and severe wasting is invariable. Deterioration in cerebral functions appears early and progresses to a state of severe incapacity with generalised muscular weakness and wasting. Pulmonary involvement is commonly found. Anaemia of severe degree is an early sign but thrombocytopenia develops late, in contrast to its early appearance in Gaucher disease. In some affected infants, ophthalmoscopy reveals a cherry-red spot at the macula resembling the retinal appearance in Tay-Sachs disease and corneal opacities may be found.

Confirmation of diagnosis depends on demonstration of increased sphingomyelin levels in tissue specimens (usually liver or spleen) and/or identification of a specific sphingomyelinase deficiency in white blood cells, fibroblasts or visceral specimens.

In type B (chronic non-neuropathic), there is a slightly later onset and no evidence of CNS impairment. Pulmonary infiltration can predispose to recurrent respiratory infections. In type C (chronic neuropathic), there is gradual onset, usually after the age of 18 months, of neurological impairment manifest as ataxia, loss of speech with dysarthria and convulsions. Most die before the age of 15 years.

### Treatment

Currently there is no specific therapy for type A or B Niemann-Pick disease. In type C, miglustat may prevent further deterioration.

## GM2 Gangliosidosis (Tay-Sachs Disease; Sandhoff Disease)

### Aetiology

An abnormal accumulation of GM2 ganglioside is confined to the brain resulting in progressive cortical failure and

death by 2.5–5 years of age. These are complex lipids and their catabolism involves a succession of enzymes of which hexosaminidase is lacking in Tay-Sachs disease. There are two hexosaminidases in the body, hexosaminidases A and B. In classical Tay-Sachs disease (type 1)—commonly seen in Ashkenazi Jews—only hexosaminidase A is lacking; in the non-Jewish form (type 2: Sandhoff disease), which is clinically indistinguishable, both A and B are absent. There are also extremely rare adult and juvenile forms which have their onset after the age of 1 year and in which hexosaminidase A activity is from 10% to 12% of normal. All types are inherited as autosomal recessive.

### Clinical Features

In this disease because the deposition of lipid is confined to the CNS the features are neurological in character. They appear between the ages of 4 and 6 months as delay in psychomotor development, irritability, hyperacusis for sudden noises, spasticity, generalised weakness and muscle wasting. An outstanding feature is progressive loss of vision leading to complete blindness. The deep reflexes are exaggerated, at least to begin with, and the plantar responses are extensor. Ophthalmoscopy reveals primary optic atrophy and the diagnostic macular cherry-red spot on each side, surrounded by a greyish-white halo appearance (Fig. 20.5). Convulsions may occur. Ultimately there are dysphagia, dementia, blindness and a tendency to repeated respiratory infections due to accumulation of mucus. Diagnosis can be confirmed by enzyme estimations on leucocytes or in skin fibroblasts grown in tissue culture. Death usually occurs before the age of 3 years.



Fig. 20.5: "Cherry-red" spot in the fundus of a Tay-Sachs infant



### Treatment

None is available. Heterozygote screening in Ashkenazi Jewish populations, where a carrier rate of 1 in 27 is found, with appropriate genetic counselling can reduce the disease incidence.

## GM1 Gangliosidosis

### Aetiology

There is accumulation of GM1 gangliosides due to defect in  $\beta$ -galactosidase activity. There are two distinct forms: (1) juvenile GM1 gangliosidosis (type II) and (2) generalised gangliosidosis (type I). In type I, gangliosides accumulate in the brain, viscera and bones; in type II, the accumulation is only in the neurones.

### Clinical Features

In generalised GM1 gangliosidosis (type I) neurological manifestations—hyperacusis, muscle weakness, incoordination, convulsions, loss of speech, mental retardation—develop during infancy and progress inexorably. Splenomegaly and hepatomegaly develop and in due course facial and skeletal changes resembling those of gargoylism become more obvious. Eye changes include macular degeneration, cherry-red spot, nystagmus and blindness. The full clinical picture is rarely present before the age of 18 months. Diagnosis can be based upon enzyme assays in leucocytes, and rectal biopsy will also reveal characteristic changes. Death occurs before the age of 5 years.

In the juvenile form (type II), the viscera are not involved and the bones only to a slight degree. Slowly progressive neurological deterioration is the principal feature. Diagnosis is suggested by MPS type dysmorphism (with normal urinary mucopolysaccharides), eye changes, multi-vacuolated foam cells in the bone marrow and vacuolisation of lymphocytes in peripheral blood smear.

### Treatment

None is available.

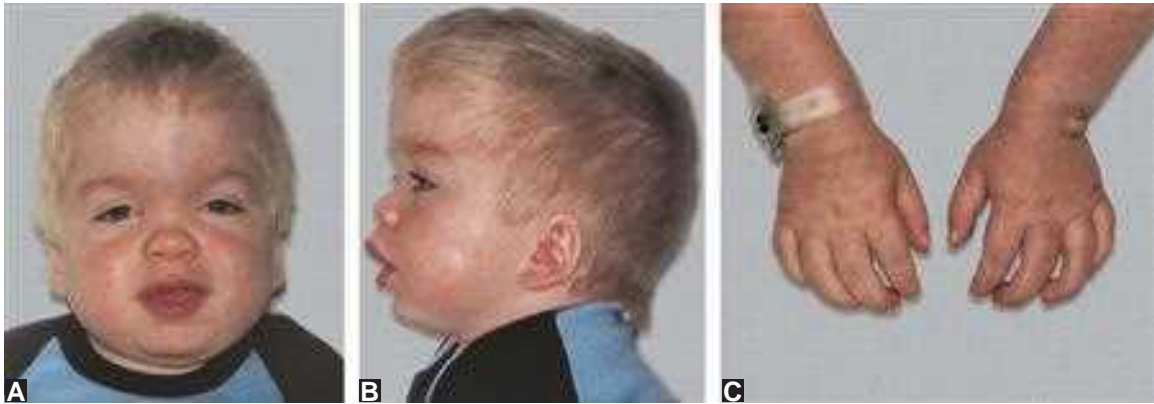
## THE MUCOPOLYSACCHARIDOSES

This group of disorders, classified into six types, is characterised by the widespread intracellular deposition of complex substances called mucopolysaccharides or sulphated glycosaminoglycans. They present primarily as disorders of the reticuloendothelial system or as progressive disorders with visceral and skeletal manifestations. The mucopolysaccharides, which appear in the urine, show variations between the different clinical types and this is of help in differential diagnosis. All types are inherited as autosomal recessive, except Hunter syndrome (MPS

type 2) in which transmission is sex-linked recessive. The aetiology appears to be a defect in the degradation of the mucopolysaccharides to their constituent sugars, this being related to a deficiency of one of the several lysosomal enzymes, each of which normally breaks a specific bond in the mucopolysaccharide molecule. Specific enzyme deficiencies have now been identified. In Hurler syndrome (MPS type 1-H), the missing enzyme activity is  $\alpha$ -L-iduronidase and in Scheie syndrome (MPS type 1-S), the same enzyme is absent in spite of marked clinical differences. In Hunter syndrome, the missing enzyme is iduronate-2-sulphatase. Sanfilippo syndrome (MPS type 3), however, appears in biochemical terms to be four diseases: (1) Sanfilippo A—due to deficiency of heparan sulphatase, (2) Sanfilippo B—related to N-acetyl- $\alpha$ -glucosaminidase, (3) Sanfilippo C—related to Acetyl CoA:  $\alpha$ -glucosaminidase N-acetyl-transferase and (4) Sanfilippo D—related to N-acetyl- $\alpha$ -D-glucosamine-6-sulphatase. There are two forms of Morquio disease (MPS type 4), types A and B, due to defect in galactosamine-6-sulphate sulphatase and  $\beta$ -galactosidase, respectively. In the Maroteaux-Lamy syndrome (MPS type 6), the enzyme deficiency is of arylsulphatase B. A few cases of "atypical" Hurler syndrome has been described in which  $\beta$ -glucuronidase was the missing factor and is referred to as MPS type 7 or Sly syndrome.

## Mucopolysaccharidosis Type 1 (Hurler Syndrome)

This type of MPS is associated with excessive amounts of dermatan sulphate and heparan sulphate in the urine in a ratio of about 2:1. There is deficiency of  $\alpha$ -L-iduronidase. The superficial appearances in a typical case of "gargoylism" allow immediate diagnosis (Figs 20.6A to C). The head is large and scaphocephalic. The eyes are set wide apart and there are heavy supraorbital ridges and eyebrows. The nose is broad with a flattened bridge and the lips are thick. The skin is dry and coarse. The cornea usually shows a marked spotty type of opacity or cloudiness. The neck is short, there is a lumbodorsal kyphosis and the protuberant abdomen often has an umbilical hernia. The spleen and liver are considerably enlarged. The hands tend to be broader than they are long. There is characteristic limitation of extension (but not of flexion) in many joints, most marked in the fingers. The fourth and fifth fingers may be short and curved towards the thumb. Genu valgum and coxa valga are common. There are also very characteristic radiological changes in the bones. The skull shows an elongated sella turcica, widened suture lines and an unduly large fontanelle. The long bones and phalanges are broader and shorter than normal and they are often bizarre in shape. The ribs too are excessively thick. The pelvis is distorted with abnormal acetabula. The vertebral bodies have an abnormal shape with concave anterior and posterior margins and there is often a hook-like projection



**Figs 20.6A to C:** MPS type 1-H: Hurler syndrome

from the anterior border of the first or second lumbar vertebra, which tends to be displaced backwards. Bone age is usually delayed. Affected children are severely mentally retarded. They show diminished physical activity. This is partly due to excessive breathlessness on exertion when the heart is involved. Cardiomegaly, precordial systolic and diastolic murmurs, and electrocardiographic evidence of left ventricular hypertrophy are commonly found. Death takes place before adult life from congestive cardiac failure or intercurrent respiratory infection.

While the child with this disorder somewhat resembles a cretin, there are very obvious clinical differences, e.g. corneal opacity, hepatosplenomegaly, limitation of extension of the interphalangeal joints, and characteristic radiological findings in the skeleton. The precise diagnosis should be based on demonstration of the specific enzyme deficiency in leucocytes or cultured fibroblasts.

### **Mucopolysaccharidosis Type 2 (Hunter Syndrome)**

This form of MPS is X-linked. It differs from Hurler syndrome in usually being less severe, but there is a severe form which results in death by the age of 15 years and a milder variety with survival to middle age. Clouding of the cornea does not occur but deafness is common. The urine contains large amounts of dermatan sulphate and heparan sulphate in approximately equal quantities. By 12 months of age radiographs show a mild but complete pattern of dysostosis multiplex.

### **Mucopolysaccharidosis Type 3 (Sanfilippo Syndrome)**

In this variety heparan sulphate is excreted in the urine almost exclusively. Mental deficiency is severe and there may be hyperactivity and destructive behaviour. Visceral and corneal involvement is relatively mild and the only skeletal signs may

be biconvexity of the vertebral bodies and some degree of claw hand. There may also be a very thick calvarium.

### **Mucopolysaccharidosis Type 4 (Morquio Syndrome)**

This is probably the disease first described by Morquio in Montevideo in 1929. The urine contains large amounts of keratan sulphate, a mucopolysaccharide that is unrelated to dermatan or heparan sulphate. Mental deficiency is not a usual finding and the face and skull are only slightly affected. The neck is short, there is marked dorsal kyphosis and the sternum protrudes. The arms are relatively long for the degree of dwarfism and may extend to the knees. There is, however, no limitation of flexion of the fingers. Genu valgum with enlarged knee joints and flat feet are present. There is a waddling gait. Radiographs may reveal platybasia, fusion of cervical vertebrae and flattening of the vertebral bodies; odontoid dysplasia predisposes to atlanto-axial subluxation with the risk of acute or chronic cervical cord compression. The metaphyses of the long bones may be irregular and the epiphyses are misshapen and fragmented. Mild degrees of corneal opacity may appear at a late stage of the disorder.

### **Mucopolysaccharidosis Type I-S (Previously Type 5): Scheie Syndrome**

The outstanding features are stiff joints, aortic regurgitation and clouding of the cornea (most dense peripherally). The facies shows the characteristics of gargoylism to a lesser extent than in Hurler syndrome, intellect is but mildly impaired and survival to adulthood is common. The urine shows the same distribution of mucopolysaccharides as in Hurler syndrome.

### **Mucopolysaccharidosis Type 6 (Maroteaux-Lamy Syndrome)**

The principal features are severe corneal and skeletal changes as in Hurler syndrome and valvular heart disease,



**Fig. 20.7:** MPS type 6: Maroteaux-Lamy syndrome

but mental deficiency does not occur. Hepatosplenomegaly is usually of mild degree. The somatic features in the severe form of Maroteaux-Lamy syndrome are similar to that in Hurler syndrome (Fig. 20.7). The urine contains dermatan sulphate almost exclusively.

### Mucopolysaccharidosis Type 7 (Sly Syndrome)

The principal features are unusual facies, protruding sternum, hepatomegaly, umbilical hernia, thoracolumbar gibbus, marked vertebral deformities and moderate mental deficiency.

#### Treatment

In all types of MPS, the parents must be given genetic counselling and prenatal diagnosis is also possible. Encouraging results in MPS are being obtained with early bone marrow transplantation when an appropriate well-matched donor is available. Specific ERT for five MPS disorders exist, but have little, if any, effect on neurological aspects.

## MITOCHONDRIAL DEFECTS

Energy, in the form of ATP, is generated by oxidative phosphorylation of breakdown products of metabolic fuels such as glucose, fatty acids, ketone bodies and organic and amino acids in the mitochondria. This breakdown of nutrient fuels (oxidation) generates reduced factors such as NADH and reduced flavo-proteins. These must be re-oxidised for re-utilisation in this process by the respiratory chain. The mitochondrial respiratory chain is a series of five complexes situated within the inner mitochondrial membrane. There

are also two small mobile electron carriers (ubiquinone and cytochrome C) involved in the process. Energy substrates cross the double phospholipid mitochondrial membrane usually with a specific carrier (L-carnitine). The proton pumps of the respiratory chain components produce an electrochemical or proton gradient across the inner membrane and this charge is subsequently discharged by complex V and the energy thus released is used to drive ATP synthesis.

### Clinical Presentation

The first of the mitochondrial respiratory chain diseases were described in relation to disorders of muscle and this resulted in the term mitochondrial myopathies. It is now known that other tissues particularly the brain may be involved. Respiratory chain defects may produce isolated myopathy, eye movement disorder (ophthalmoplegia) with or without myopathy and occasionally with CNS dysfunction such as ataxia, multisystem disease, fatal lactic acidosis of infancy and single organ dysfunction such as cardiomyopathy. The encephalopathies contain a number of recognisable syndromes such as the Kearns-Sayer syndrome characterised by progressive external ophthalmoplegia, pigmentary retinopathy and heart block, myoclonus epilepsy with ragged-red fibres (MERRF) where in addition to myoclonic seizures there is weakness, ataxia, deafness and dementia. Myopathy, encephalopathy, lactic acidosis and stroke-like episodes (MELAS) is characterised by the recurrence of stroke-like episodes with onset usually before the age of 15 years. Cortical blindness and hemianopia usually accompany the stroke-like episodes which may be preceded by a migraine-like headache, nausea and vomiting. Dementia frequently ensues. Another syndrome known as NARP is comprised of neurogenic weakness, ataxia and retinitis pigmentosa. Unlike the other syndromes described there are no morphological changes in skeletal muscle and the mitochondrial DNA (mtDNA) defect affects ATP synthesis.

Leigh syndrome of sub-acute necrotising encephalomyopathy presents with vomiting, failure to thrive, developmental delay, muscular hypotonia and respiratory problems. There may also be ophthalmoplegia, optic atrophy, nystagmus and dystonia. The disorder usually presents at around the age of 6 months but may be present from birth or may not appear until late teenage. In Leigh encephalopathy like many of the mitochondrial syndromes, it is difficult to pinpoint a single biochemical abnormality. There are defects of the respiratory chain, pyruvate dehydrogenase complex and biotinidase, which variably present with this syndrome. Lactate and pyruvate concentrations are frequently elevated in blood and CSF and MRI scans show characteristic low density areas within the basal ganglia or less commonly the cerebellum. There is occasionally an autosomal recessive pattern of

inheritance in Leigh syndrome, which suggests that it may be caused by a nuclear gene rather than a mitochondrial defect. However, in some patients mutations have been found in mtDNA. There are some patients who do not fit into these clinical patterns of disease and many have been shown to have multiple defects of respiratory chain complexes due to mtDNA disorder.

Leber hereditary optic neuropathy (LHON) is one of the commonest inherited causes of blindness in young men due to a disorder of mtDNA. Some men with the disorder have an encephalopathy with deafness and dystonia and a few develop cardiac conduction defects. There is some evidence that a gene on the X-chromosome may be linked with this disorder.

There are a variety of syndromes with non-neuromuscular presentation, which involve the gastrointestinal tract with anorexia and vomiting and occasionally hepatic failure; yet others have cardiomyopathy with different degrees of heart block, renal disease with generalised aminoaciduria and haematological disorders affecting bone marrow function. In Pearson syndrome, which presents at birth or early infancy there is refractory sideroblastic anaemia, thrombocytopenia, neutropenia, metabolic acidosis, pancreatic insufficiency and hepatic dysfunction. Renal tubular disorder, diarrhoea, steatorrhoea and skin lesions with eventual liver failure have been described. Deletions of mtDNA have been identified.

Many of the respiratory chain disorders may present in the very young but there are three specific syndromes affecting the infant. The first is fatal infantile lactic acidosis. Infants present with hypotonia, vomiting and ventilatory failure and die often before the age of 6 months. A generalised aminoaciduria (de Toni-Fanconi-Debré syndrome), grossly increased plasma lactate concentrations, hypoglycaemia, liver dysfunction, convulsions and increased plasma calcium have been reported. The second clinical presentation is benign infantile lactic acidosis, which may present with failure to thrive, respiratory failure and hypotonia with increased plasma lactate concentrations but the condition gradually remits and by 12–18 months these infants are often normal. There is a cytochrome oxidase defect, which appears to improve with age and may be related to a switch from a fetal to an adult form of complex IV. The third syndrome is the mtDNA depletion syndrome in which the infant is weak, hypotonic and has respiratory difficulties together with renal tubular disorder and convulsions. The condition is usually fatal before the age of 1 year.

### Treatment

Children with respiratory chain defects have been treated with vitamin C (4 g/day), vitamin K (menadione: 50 mg/day) and ubiquinone (100 mg/day) in the hope that these vitamins

may act as artificial electron acceptors. Some improvement in electron transfer has been suggested by nuclear magnetic resonance (NMR) studies in these patients but there is some doubt as to the overall clinical benefit. Other treatments have included thiamine, biotin, L-carnitine, riboflavin and dichloroacetate. As the mitochondrial respiratory chain generates free radicals, scavengers such as vitamin E might be of some clinical benefit. Unfortunately most of these conditions are progressive and result in significant disability and/or death. Considerable support of the families involved is required during the care of these infants and genetic counselling with prenatal diagnosis is available for some of these conditions.

## PEROXISOMAL DISORDERS

Peroxisomes are present in every body cell except the mature erythrocyte and are particularly abundant in tissues active in lipid metabolism. They do not contain DNA and are, therefore, under the control of nuclear genes. Peroxisomes have a number of metabolic functions—particularly:

- Fatty acid  $\beta$ -oxidation of very long-chain fatty acids (VLCFAs), pristanic acid and cholestanoate compounds which are intermediates in biosynthesis of bile acids
- Plasmalogen synthesis
- Phytanic acid oxidation—a branch-chain fatty acid formed from chlorophyll metabolism, and
- Glycolate detoxification preventing formation of oxalate.

Over sixteen clinical and biochemical disorders have now been ascribed to disorders of peroxisomal metabolic functions.

Table 20.2 gives a tentative classification of the peroxisomal disorders. In the group 1 disorders, there is a reduction or absence of functional peroxisomes. Zellweger syndrome is a lethal disease presenting with severe hypotonia, typical craniofacial abnormality with a high domed forehead, severe developmental delay with neurosensory defects and progressive oculo-motor dysfunction. These neurological abnormalities may be related to the neuronal migration disorders found in the brain at post-mortem. There is also progressive liver dysfunction with chondrodysplasia calcificans of the patellae and the acetabulum. In neonatal adrenoleukodystrophy (ALD), there is progressive demyelination of the cerebral hemispheres, cerebellum and brainstem with neuronal migration disturbances and perivascular lymphocytic infiltration. There is also adrenal atrophy. In infantile Refsum disease (IRD), there is developmental delay, retinitis pigmentosa, failure to thrive and hypocholesterolaemia. In the group 2 disorders, rhizomelic chondrodysplasia punctata (RCDP) is an autosomal recessive disorder characterised by short stature, a typical facial appearance, joint contractures and

**Table 20.2:** Classification of peroxisomal disorders

1. Peroxisome deficiency disorders
  - Neonatal adrenoleukodystrophy
  - Infantile Refsum disease
  - Hyperpipecolic acidaemia
2. Disorders with loss of multiple peroxisomal functions and peroxisome structure in fibroblasts
  - Rhizomelic chondrodysplasia punctata
  - Zellweger-like syndrome
3. Disorders with an impairment of only one peroxisomal function and normal peroxisomal structure
 

Disorders of peroxisomal  $\beta$ -oxidation:

  - Adrenoleukodystrophy (X-linked) and variants
  - Acyl-CoA oxidase deficiency
  - Bi (multi) functional protein deficiency
  - Peroxisomal thiolase deficiency

Other disorders:

  - Acyl-CoA: Dihydroxyacetonephosphate acyltransferase (DHAPAT) deficiency
  - Primary hyperoxaluria type I

Acatalasaemia

  - Glutaryl oxidase deficiency

X-ray changes showing stippling of the epiphyses in infancy and severe symmetrical epiphyseal and extra-epiphyseal calcifications in later life. Only few patients have been described as having the Zellweger-like syndrome which is clinically indistinguishable from the classical Zellweger but shows abundant peroxisomes in the liver. In the group 3 disorders with impairment of a single peroxisome function and with a normal peroxisome structure ALD, an X-linked recessively inherited disorder, usually affects males between the ages of 4 and 10 years.

Initially there may be attention deficit noticed in school followed by convulsions, visual disturbance with the later manifestations of paralysis and death. This phenotype known as childhood ALD has been treated with long-chain polyunsaturated fatty acids but there is some doubt as to the

overall benefit of this form of therapy. About 25% of ALD cases present in adulthood with paraparesis whilst a few may exhibit adrenocortical insufficiency without neurological involvement. About 20% of female heterozygotes develop mild or moderate progressive paraparesis after the age of 40 years.

The other disorders are also rare apart from primary hyperoxaluria type I, an autosomal recessive disorder of glyoxylate metabolism, in which there is recurrent calcium oxalate nephrolithiasis and nephrocalcinosis presenting during the first decade. There are a few, however, who present with an acute neonatal form of the disorder and early death.

### Treatment

Apart from the attempt to treat X-linked ALD with fat restriction and supplementation with glycerol trioleate and glycerol trierucate, which has been shown to improve peripheral nerve function, but not as yet to effect long-term benefit there are recent reports that bone marrow transplantation may be effective in mildly affected childhood ALD patients. In more advanced X-linked ALD, bone marrow transplantation worsened the clinical picture. It is hoped that gene therapy might improve the outlook for this condition. Treatment with pyridoxine may be effective in a small number of patients with primary hyperoxaluria type I. Haemodialysis may be required during end-stage renal failure in this disease and surgical removal of oxalate stones may be required. Eventually combined liver and kidney transplant becomes necessary for survival.

### CONCLUSION

Although individual inherited metabolic diseases are rare and this book contains only a limited review of some of the disorders, collectively they form a major grouping of disorders causing significant mortality and an overwhelming burden of morbidity for families and the community.

# Endocrine Disorders

## HYPOPITUITARISM

Embryologically the pituitary gland is formed from the Rathke pouch, a diverticulum of the stomodeal ectoderm and the neuroectoderm of the floor of the forebrain. A number of signalling molecules and transcription factors are involved in pituitary organogenesis and the differentiation of the different cell lineages: somatotropes [growth hormone (GH)], lactotropes (prolactin), corticotropes (adrenocorticotrophic hormone), thyrotropes [thyroid-stimulating hormone (TSH)] and gonadotropes [LH, follicle-stimulating hormone (FSH)]. Multiple pituitary hormone deficiencies can result from malformations of the hypothalamus and pituitary gland or mutations of these transcription factors. Patients with mutations in the pituitary transcription factors have other anomalies associated with hypopituitarism. POU1F1 is the first pituitary transcription factor to be cloned and mutations result in defects in somatotrope, lactotrope and thyrotrope development. Mutations in Prophet of PIT1 (PROP1) lead to combined pituitary hormone deficiency including GH, TSH, prolactin, and adrenocorticotrophic hormone in later life. Mutations in PROP1 accounts for 50% of the cases of genetically determined combined pituitary hormone deficiency. Secretion of hormones from different lineages of pituitary cells is dependent on hypothalamic-releasing factors [gonadotrophin-releasing hormone (GnRH), thyrotrophin-releasing hormone (TRH), corticotrophin-releasing hormone, growth hormone-releasing hormone (GHRH)] or suppressive hormone like somatostatin. Two hormones are secreted by the posterior pituitary gland: (1) vasopressin and (2) oxytocin. Vasopressin is important for the re-absorption of water by the distal renal tubules and collecting ducts. Vasopressin release is stimulated by rising plasma osmolality; fall in blood volume or blood pressure or by stress. Oxytocin release is stimulated by suckling and its role is limited to the puerperal period. Causes of hypopituitarism are shown

in Table 21.1. Extent of the anterior and posterior pituitary dysfunction depends on the extent of the damage.

### Clinical Features

The usual presenting features include symptoms and signs relating to the hormonal deficiencies or the underlying cause of hypopituitarism. Patients with mutations in the LIM homeobox genes (LHX3, LHX4) have hypopituitarism and malformation of the skull base and cervical spine. Other pituitary transcription factors mutations can be associated with abnormalities of the development of the eye and forebrain structures. Intracranial tumours in the suprasellar region can lead to visual field defects, neurological symptoms and symptoms and signs of raised intracranial pressure like headache and vomiting, papilloedema. Polyuria, polydipsia

**Table 21.1:** Causes of hypopituitarism

- Cerebral malformations—holoprosencephaly, midline facial defects, septo-optic dysplasia, congenital hypopituitarism (transection of pituitary stalk, adenohypophysis hypoplasia, ectopic position of posterior pituitary signal on MRI scan)
- Mutations of pituitary transcription factors genes (multiple pituitary hormone deficiency) or of pituitary hormone or pituitary hormone-releasing hormone genes (isolated pituitary hormone deficiency)
- Postnatal damage of hypothalamus or pituitary gland:
  - Traumatic or breech delivery
  - Head injury
  - Suprasellar or pituitary tumours, e.g. craniopharyngioma, germ cell tumour, astrocytoma, glioma, prolactinoma
  - Infiltrative lesions, e.g. Langerhans cell histiocytosis, sarcoidosis, lymphocytic hypophysitis
  - Pituitary apoplexy
  - Infection, e.g. meningitis, encephalitis
  - Autoimmune
  - Cranial irradiation
  - Pituitary haemosiderosis, e.g. transfusion dependent thalassaemia major

and dehydration may or may not be present depending on whether there is posterior pituitary involvement. Short stature and infantile body proportions are common due to GH and thyroid hormone deficiencies. Adrenal insufficiency can lead to lethargy, hypoglycaemia, nausea, vomiting or even shock when the patient is under stress. In infants with hypopituitarism, the presenting features include recurrent hypoglycaemic attacks, micropenis in males (stretched penile length <2.5 cm), persistent neonatal jaundice resembling the neonatal hepatitis syndrome. Microphthalmia, pendular nystagmus, optic nerve hypoplasia and signs of hypopituitarism suggest septo-optic dysplasia. Early onset of symptoms indicates a congenital or genetic cause of hypopituitarism. A proper history can usually shed light on the aetiology of postnatal damage to the hypothalamus and pituitary gland.

### Investigations

Assessment begins with the documentation of anthropometric data using standard techniques and the state of the development of the genitalia and pubertal staging. An X-ray for bone age as assessed by the Greulich and Pyle and Tanner-Whitehouse Atlas will usually show retardation of skeletal maturity (Fig. 21.1) relative to the chronological age. Baseline fasting morning cortisol, thyroid hormone, TSH, prolactin, gonadotrophins and sex steroids (in pubertal age group) should be taken and one should proceed to combined pituitary hormone assessment (tests for stimulating GH and cortisol secretion together with TRH and luteinising hormone-releasing



**Fig. 21.1:** Bone age: X-ray of the left hand and wrist of a boy aged 4 years and 3 months. The bone age using the TW II 20-bone score (Tanner-Whitehouse) is 3.8 years which is just below the 50th percentile for his age

hormone (LHRH) test if there is a strong clinical suspicion of hypopituitarism. Imaging of the hypothalamus and pituitary preferably with magnetic resonance imaging (MRI) is required after establishing a hormonal diagnosis of hypopituitarism.

### Treatment

Hormonal replacement for adrenal, thyroid, gonadotrophin and GH deficiency will be discussed in subsequent relevant sections of this chapter.

## DISORDERS OF THE POSTERIOR PITUITARY

### Diabetes Insipidus

The prohormone of vasopressin is synthesised in the cells of the supraoptic and paraventricular nuclei and granules of propressophysin are rapidly transported through the axons by axoplasmic streaming and stored in the axon terminals in the posterior pituitary gland. Central diabetes insipidus (DI) is due to vasopressin deficiency and the causes are shown in Table 21.2. The patients present with polyuria, polydipsia, nocturia, or secondary enuresis, passing inappropriate large volumes of dilute urine (more than 2 L/m<sup>2</sup> per day). Affected children could be admitted in a severe dehydrated state. Patients with craniopharyngioma or other suprasellar tumours can present with signs of raised intracranial pressure, visual field defects, growth failure or symptoms of pituitary hormone deficiencies. Central DI must be distinguished from other causes of polyuria like diabetes mellitus, nephrogenic DI, renal tubular disorders, hypokalaemia, hypercalcaemia, obstructive uropathy. More than 90% of nephrogenic DI results from mutations in the vasopressin receptor (V2R) on chromosome Xq28-qter. Autosomal recessive form of nephrogenic diabetes insipidus (NDI) is due to mutations in the aquaporin 2 gene (AQP2) on chromosome 12q12-q13. Patients usually present in infancy with polyuria, polydipsia, failure to thrive, unexplained fever, and constipation. The

**Table 21.2:** Causes of vasopressin deficiency

- Tumour (38%)
  - Craniopharyngioma, optic glioma, germinoma
- Vascular
  - Sickle-cell disease, haemorrhage, shock infection
- Hereditary
  - Familial CDI, X-linked DI, Wolfram syndrome
- Cerebral malformation (3.2%)
  - Septo-optic dysplasia, empty sella, Bardet-Biedl syndrome
- Trauma (1.6%)
- Infiltrative
  - Histiocytosis (8%), leukaemia
- Miscellaneous
  - Idiopathic (20–30%), autoimmune

baby often prefers water to milk. Developmental delay can occur due to severe hypernatraemic dehydration in infancy. In a patient suspected of suffering from DI, an accurate documentation of the daily fluid intake and urine output is required. If the patient is admitted in dehydration with serum sodium of greater than 150 mmol/L and a plasma osmolality greater than 300 mOsmol/kg, a simultaneous urine osmolality less than 750 mOsmol/kg is suggestive of DI. A water deprivation test is required for diagnosis in a patient who can compensate for the defect in urine concentration by excessive water drinking.

The water deprivation test must be done under medical supervision. The patient must be allowed to drink ad libitum overnight and the patient must be well-hydrated in the morning before the test. Fluid is then withheld with hourly monitor of: (a) urine volume and osmolality, (b) body weight, (c) plasma sodium and osmolality, and (d) clinical status, pulse, blood pressure and perfusion. The end-point of the test is: (a) loss of 3–5% body weight, (b) serum sodium greater than 150 mmol/L and osmolality greater than 300 mOsmol/kg and the diagnosis of DI is reached if the urine osmolality fails to reach greater than 750 mOsmol/kg at the end-point of the test. Vasopressin responsiveness is established by giving desmopressin (1 month to 2 years: 5–10 µg and 2–12 years: 10–20 µg intranasally) or arginine vasopressin (1 unit/m<sup>2</sup> subcutaneously) at the end of water deprivation and urine volume and osmolality should be assessed hourly for a further 3 hours after desmopressin. In central DI, urine volume will fall and there should be a rise of the urine osmolality at least by 120 mOsmol/kg above the peak value achieved during the water deprivation test.

After reaching a diagnosis of central DI, one should look for an underlying cause. Investigations should include a full blood count, skeletal survey (for osteolytic lesions), alpha-foetoprotein and human chorionic gonadotropin (germinoma) and MRI of the brain. MRI of the brain is preferred to look for suprasellar lesions (craniopharyngioma, optic glioma, germinoma), thickening of the pituitary stalk (histiocytosis, germinoma, lymphocytic hypophysitis) and loss of posterior pituitary “bright spot” on T1-weighted images.

### Treatment

Patients with central DI could be treated with oral desmopressin (2–12 years: 100–800 µg daily in divided doses) or by the buccal route. About 60 µg of buccal DDAVP is approximately equivalent to 0.1 mg of oral DDAVP. The dosage is adjusted according to the response. Treatment of patients with nephrogenic DI includes a diet restricted in sodium (0.7 mmol/kg per day) and protein (1–1.25 g/kg per day) but normal caloric content together with an appropriate fluid intake according to age. Hydrochlorothiazide (2–3 mg/

kg per day) and amiloride (0.3–0.5 mg/kg per day) and indomethacin (1–3 mg/kg per day) can be used to enhance control. The management of the underlying pathology leading to central DI must also be adequately addressed.

## Syndrome of Inappropriate Antidiuretic Hormone Secretion

Syndrome of inappropriate antidiuretic hormone (SIADH) comprises aetiologically heterogeneous conditions leading to retention of water with plasma hypo-osmolality (<270 mOsmol/kg), normal or slightly increased effective blood volume with less than maximally dilute urine (>100 mOsmol/kg) and absence of adrenal, thyroid or renal insufficiency. Causes of SIADH are shown in Table 21.3. The symptoms consist of apathy, confusion, anorexia, headaches, muscle cramps and in several cases convulsion and coma.

Severe symptomatic hyponatraemia can be corrected by slow infusion of 3% sodium chloride 4–6 ml/kg over 1 hour and this will raise the serum sodium by about 5 mmol/L and the correction of hyponatraemia should not be faster than a rise of serum sodium concentration of 10–12 mmol/L per day due to the risk of central pontine myelinolysis. Milder cases should be managed by fluid restriction. Ideally one should anticipate and prevent the development of SIADH by monitoring the fluid balance, body weight and electrolytes in at-risk patients.

## SHORT STATURE

The factors governing human growth have already been described in the Chapter 2 (Growth and Development). Short stature is common but short stature due to an endocrine cause is less common. Children with a height below the 0.4th percentile (below –2.67 SD) with correction for the mean parental height (1.6 SD below the corrected mean parental height) or growing with a subnormal growth velocity should be referred for specialist care. A genetic cause of GH deficiency can be suspected if there is early onset of growth failure, a positive family history or consanguinity, extreme

**Table 21.3:** Causes of SIADH

- Central nervous system disorders
  - Meningitis, encephalitis, intracranial tumours or haemorrhage
- Respiratory tract disease and infection
- Decreased left atrial filing
  - Positive pressure ventilation, pneumothorax, cystic fibrosis
- Drugs
  - Carbamazepine, vinca alkaloids
- Malignancies
  - Thymoma, bronchogenic carcinoma, lymphoma, Ewing sarcoma
- About 35% of HIV patients have SIADH due to pneumocystis infection or malignancy



**Table 21.4:** Causes of short stature

- Genetic short stature
- Constitutional delay in growth and puberty
- Undernutrition
- Chronic illness of all major systems, e.g. chronic renal failure, inflammatory bowel disease, congenital heart disease, inherited metabolic diseases, thalassaemia major
- Psychosocial deprivation
- Syndromal and chromosomal disorders, e.g. Turner syndrome, Noonan syndrome, Silver-Russell syndrome, Prader-Willi syndrome, William syndrome, Down syndrome
- Skeletal dysplasia, e.g. hypochondroplasia, achondroplasia, spondylo-epiphyseal dysplasia

short stature and an extremely low GH response to GHRH, low serum IGF-1 and IGFBP-3 levels (see below). The causes of growth failure are shown in Table 21.4. Idiopathic short stature accounts for 60–80% of children with a height below  $-2$  SD and includes constitutional delay in growth and puberty (CDGP) and familial short stature.

### Assessment of Short Stature

The height, span, upper to lower (U/L) segment ratio and previous growth record are important auxiological data. Disproportionate short stature is indicative of skeletal dysplasia. Initial investigations should include full blood count, sedimentation rate, serum calcium, phosphate, alkaline phosphatase, IGF-1, renal and liver function tests, acid-base status, thyroid hormone, thyroid-stimulating hormonal and X-ray for bone age. A short child with normal growth velocity and no bone age delay and a plasma IGF-1 level above the mean for age, does not require GH testing. If the serum IGF-1 and IGFBP-3 are lower than  $-1$  SD for age in a child with significant short stature and subnormal growth velocity, then the GH/IGF-1 axis should be investigated. GH deficiency is diagnosed by an inadequate GH response of less than 20 mIU/L measured by a polyclonal radioimmunoassay (RIA) or an equivalent lower value using a two-site GH immunoassay, to two pharmacological stimuli like clonidine, L-dopa, arginine, glucagon, GHRH or insulin induced hypoglycaemia. The latter test is not favoured by some paediatric endocrinologists and should not be used in children under 5 years and of age. Assessment of the hypothalamic-pituitary adrenal axis and the gonadotrophins and TSH responses to their respective hypothalamic-releasing hormone should be performed when pituitary dysfunction is suspected (glucagon and LHRH and TRH test). It is important that hypothyroidism be diagnosed and adequately treated before any investigation of the GH/IGF-1 axis. Adrenal insufficiency is diagnosed when the plasma cortisol fails to reach 500 nmol/L in response to glucagon or insulin induced hypoglycaemia. Neuroimaging with MRI is indicated in

patients diagnosed with GH deficiency or multiple pituitary hormone deficiency. Children with constitutional delay in growth and puberty (CDGP) have slow physical and pubertal maturation and a delay in bone age. The diagnosis can only be made after the other causes of short stature have been excluded.

### Treatment

In children with CDGP, the final adult height although normal, is usually short of the predicted target height based on parental stature. Management includes an explanation to the parents of the natural growth pattern and the reasonable height prognosis of such children. Short courses of oxandrolone or testosterone can be used if short stature or lack of sexual development is causing significant psychosocial difficulties, but GH treatment is not indicated.

Growth hormone has been approved for treatment of GH deficiency, short stature associated with chronic renal failure, Turner syndrome, Prader-Willi syndrome, small for gestational age (SGA) children who have not caught up in growth by 3–4 years of age and idiopathic short stature. The recommended growth hormone dosage is 0.7 IU/kg/week (GHD) to 1.2–1.4 IU/kg/week in short SGA children divided into 5–7 doses per week. The improvement in adult height is most significant in patients with GH deficiency and early diagnosis and prompt treatment will improve the final height. A dose of GH in the range of 1 unit/kg per week in divided doses is used for the treatment of Turner syndrome, chronic renal failure and idiopathic short stature. The GH dosage can be individualised and adjusted to keep the serum IGF-1 level in the age-specific upper normal range. An improvement in the height velocity of at least 3 cm per year above the pre-treatment growth velocity or height velocity greater than  $+1$  SD is needed to justify continuation of treatment. Recently, short children with the exon 3-deleted GH receptor variant had been shown to have a better growth response to GH treatment but this observation has not been universally replicated by other authors. The growth, skeletal maturation, pubertal assessment and possible side effects must be regularly monitored during GH treatment. GH treatment in childhood is relatively safe. There was a concern that GH therapy in GH deficiency increased the risk of leukaemia and tumour recurrence but this fear has not been substantiated in recent well-conducted epidemiological studies. There is a risk of worsening of scoliosis or the development of slipped capital femoral epiphysis in the rapidly growing child treated with GH. GH therapy could be associated with insulin resistance and there is one recent report to suggest an increased risk of development of type 2 diabetes mellitus (T2DM) in children treated with GH. Pseudotumour cerebri can rarely occur during the early phase of GH treatment and this risk can be

minimised by starting GH at a lower dose and then increase to the recommended dose gradually.

In patients with multiple pituitary hormone deficiency, GH treatment may unmask hypothyroidism. It is necessary to monitor the thyroid function during GH treatment and to start thyroxine replacement if low free thyroxine level is detected. As glucocorticoid in higher doses may inhibit growth, a safe low replacement dose of oral hydrocortisone of 8–10 mg/m<sup>2</sup> per day in two divided doses should be used in children with adrenal insufficiency in addition to GH deficiency. Gonadotrophin deficiency can be suspected if there is micropenis since infancy in a male patient or failure to develop secondary sexual characteristics by 13 years in girls or 14 years in boys. Patients with hypogonadism can also present with arrest or delay in progress of sexual development. Puberty can be induced in boys with monthly intramuscular injections of testosterone enanthate. In females, puberty can be induced with conjugated oestrogen (premarin) or synthetic oestrogen (ethinyl oestradiol) in gradual increasing dosages and cyclical oestrogen/progestogen replacement be instituted after 1 or 2 years.

## TALL STATURE

The referral of children with tall stature to the endocrine service is not common and the patients are usually very tall girls who are worried about their heights. The causes of tall stature are shown in Table 21.5.

Beckwith-Wiedemann syndrome is characterised by prenatal and postnatal overgrowth, visceromegaly, omphalocele, hemihypertrophy and neonatal hypoglycaemia. This condition is due to epigenetic errors of the imprinted gene cluster on chromosome 11p15 or mutations of cyclin-dependent kinase inhibitor gene (CDKN1C) on chromosome 11p15. Patients with Sotos syndrome have macrodolichocephaly with prominent forehead and jaw and a characteristic growth pattern of rapid growth in early life followed by slowing of the growth velocity to normal by mid-childhood. Sotos syndrome is due to microdeletion of paternal chromosome 5 in the region of the nuclear receptor binding SET-domain containing gene 1 (NSD1) or intragenic mutation of NSD1. Epigenetic mutations in the imprinted gene cluster on chromosome 11p15 have been found in patients with the Sotos phenotype without NSD1 mutations. This suggests that an overlap of the molecular basis of overgrowth syndrome exists.

**Table 21.5:** Causes of tall stature

- Prenatal overgrowth—Beckwith-Wiedemann syndrome, Sotos syndrome, Weaver syndrome
- Postnatal overgrowth—familial tall stature, Marfan syndrome, homocystinuria, Klinefelter syndrome
- Secondary causes—obesity, precocious puberty, GH-secreting tumour, hyperthyroidism

Skeletal features of Marfan syndrome include pectus excavatum or carinatum, scoliosis, reduced U/L segment ratio and a span to height ratio greater than 1.05. Other features include ectopia lentis, dilatation of the ascending aorta or pulmonary artery, mitral valve prolapse, spontaneous pneumothorax and lumbosacral dural ectasia. A positive family history (autosomal dominant inheritance) is helpful in the diagnosis. Marfan syndrome is due to mutation in the fibrillin gene (FBN1) on chromosome 15q21.1 or rarely mutation in transforming growth factor beta receptor 2 (TGFB2) on chromosome 3p22.

Assessment of children with tall stature includes identification of syndromal disorders. The pubertal status, parental stature, thyroid status and body mass index should be noted. GH excess usually resulting from a GH-secreting pituitary tumour, leads to growth acceleration, coarse facial features, prognathism and enlarging hands and feet. Glucose intolerance or hypertension may occur. A large pituitary tumour can cause visual field defects and headache. GH excess is occasionally associated with the McCune Albright syndrome. Further investigations include measurement of thyroid hormone, testosterone, oestradiol, LH, FSH, prolactin, IGF-1, 17 $\alpha$ -hydroxyprogesterone (17 $\alpha$ -OHP). The failure of suppression of the serum GH level below 10 mIU/L during an oral glucose tolerance test (1.75 g/kg to a maximum of 75 g) remains the gold standard for the diagnosis of GH hypersecretion. Karyotyping, X-ray for skeletal maturation and MRI scan of the brain and pituitary should be performed where indicated.

Girls may seek treatment and those with a predicted final adult height greater than +3 SD could be considered for hormonal therapy (100–300  $\mu$ g ethinyl oestradiol or 7.5 mg premarin combined with medroxyprogesterone acetate 5–10 mg from day 15 to day 25 of each calendar month). Testosterone enanthate 250–1,000 mg intramuscularly every month can be used to accelerate skeletal maturation and reduce final height in tall boys. However, the use of sex hormone therapy for limiting adult height should be reserved for selected patients because knowledge in potential long-term effects and fertility is still scanty. Calf cramps and weight gain are the common side effects of high dose oestrogen in girls. In boys, acne, aggressive behaviour and hypertrichosis are the common complaints. For the other secondary causes of tall stature, treatment should be directed at the underlying condition. A pituitary GH-secreting tumour is managed by trans-sphenoidal surgery.

## OBESITY

In 1997, the World Health Organisation (WHO) press release declared that “Obesity’s impact is so diverse and extreme that it should now be regarded as one of

the greatest neglected health problems of our time with an impact on health which may well prove to be as great as that of smoking". The prevalence of obesity is on the rise in both developed and developing countries. There is currently no consistent evidence that the current epidemic of obesity is due to increased fat or caloric intake. There is an enormous range of energy intakes by children of the same age and there is little correlation between intake for age and weight for height for age. Technological advances have caused a marked reduction in the average daily energy expenditure and it appears to be the key determinant of the current obesity epidemic. Television viewing and use of the computer for leisure have now been viewed as surrogate measures of physical inactivity. As much as 28% and 46% of all children and non-Hispanic black children in the United States NHANES III survey reported watching television greater than 4 hours per day. The best estimate of genetic contribution to obesity is about 25% whereas cultural transmission of lifestyle accounting for obesity is estimated to be about 30%. As of October 2005, 176 cases of obesity due to mutations in eleven different genes have been reported and the molecular basis of at least 25 obesity syndromes is now known. There are 253 quantitative trait loci (QTLs) for obesity-related phenotypes from 61 genome-wide scans and of these 52 genomic regions harbour QTLs replicated among two to four studies (The Human Obesity Gene Map: the 2005 update). The complications of childhood obesity are shown in Table 21.6.

The increase in the prevalence of obesity has been associated with a similar increase in the prevalence of type 2 diabetes in many countries. It is recommended that screening for T2DM be performed every 2 years in obese children and adolescents who have acanthosis nigricans, a family history of type 2 diabetes and evidence of insulin resistance (acanthosis nigricans, hypertension, dyslipidaemia, and polycystic ovary syndrome).

Obese infants and children under the age of 3 years without obese parents are at low-risk of becoming obese

**Table 21.6:** Complications of childhood obesity

- Insulin resistance and type 2 diabetes mellitus
- Hyperlipidaemia
- Hypertension
- Steatohepatitis
- Respiratory inadequacy including obstructive sleep apnoea syndrome
- Musculoskeletal problems including slipped capital femoral epiphysis, genu valgum
- Tall stature and early puberty
- Gynaecomastia or adipomastia
- Oligomenorrhoea and hyperandrogenism
- Psychological sequence like poor self-image, disordered eating and nonspecific behaviour disturbances

as an adult whereas obese adolescents are at increased risk of developing adult obesity. The doctor should be able to identify obesity related syndromes and to monitor for and treat any obesity related complications developing in these obese children. Investigations to exclude a pathological cause should be undertaken if there is severe early onset of obesity or when obesity is associated with short stature or features suggestive of a syndromal disorder, e.g. Prader-Willi syndrome, pseudohypoparathyroidism, glucocorticoid excess, hypothalamic syndrome and Bardet-Biedl syndrome.

A preventive programme needs to have commitment from all stakeholders and be directed at the whole population. The preventive messages must be free from harm to those in the community who are not obese. Prevention should be directed towards developing a healthier lifestyle in the family and the community like increased physical activity, decreased dependence television and computer games for entertainment, and healthy eating. As children spend a significant part of the day at school, much can be done by schools to combat this epidemic by health education, providing healthy snacks, drinks and meals at school, and encouraging increased physical activity and fitness.

Once a child has developed significant obesity, measures to encourage weight loss and weight maintenance have proved disappointing in achieving these aims. Education on the nature and complications of obesity, healthy eating and lifestyle and psychological support on a regular basis by a team of professionals consisting of paediatricians, dietitian, exercise physiologist and psychologist have frequently been suggested but the cost-effectiveness and sustainability of such programmes have been called into question. Pharmacotherapy should be restricted to treat the most severe cases of obesity associated with complications. Sibutramine, acarbose and orlistat are drugs that can be considered. Bariatric surgery employing roux-en-y gastric bypass or adjustable gastric banding has been increasingly used to treat patients with morbid obesity and severe medical complications.

## THYROID GLAND

Disorders of the thyroid gland are, with the exception of diabetes mellitus, the most common endocrine problems of childhood. The advent of immunoassay techniques has been followed by a vast increase in our knowledge of the physiology and disturbances of thyroid function and molecular mechanism of disease.

### Hypothyroidism

A classification of the causes of hypothyroidism is shown in Table 21.7. It is designed upon an aetiological basis which will permit the clinician to systematically approach diagnosis and treatment. Of the various causes of hypothyroidism

**Table 21.7:** A classification of hypothyroidism in childhood

- Dysgenesis of the thyroid gland (may present as congenital hypothyroidism or juvenile myxoedema in childhood in milder cases)
  - Congenital athyreosis
  - Maldescent
  - Maldevelopment
- Deficiency of iodine (endemic cretinism)
- Genetic basis of congenital hypothyroidism
  - Mutations in transcription factors resulting in thyroid dysgenesis (FOXE1, PAX8, NKX2.1)
  - Mutations in the monocarboxylate transporter 8 gene (MCT8 or SLC16A2)
- Dyshormonogenesis
  - Hyporesponsiveness to TSH (TSHR or GNAS1 mutations)
  - Iodide transport defects (mutations in sodium-iodide symporter gene SLC5A5)
  - Thyroglobulin synthesis defects (defective TG gene)
  - Iodide organification defects (mutations in thyroperoxidase gene TPO or genes of dual oxidase proteins DUOX1 and DUOX2)
  - Pendred syndrome (SLC26A4 gene and FOXI1 gene mutations)
  - Dehalogenase defects (mutations in iodothyrosine deiodinase gene IYD)
- Thyroid hormone resistance (thyroid hormone receptor gene TR $\beta$  mutations)
- Ingestion of goitrogens (accidental or therapeutic)
  - Antenatal (iodine, thionamides in pregnancy)
  - Postnatal (iodine-containing radiographic contrast medium, amiodarone)
- Primary thyroid disease, e.g. autoimmune thyroiditis, carcinoma, etc.
- Pituitary hypothyroidism
  - Malformation of the brain, e.g. holoprosencephaly
  - Mutations of pituitary transcription factors
  - Secondary to disruption of the hypothalamus-pituitary-thyroid axis, e.g. tumour, infection, irradiation, haemosiderosis

in childhood only endemic iodine deficiency, congenital hypothyroidism and autoimmune thyroiditis will be described in this chapter.

### Endemic Iodine Deficiency

Iodine deficiency is now recognised as the most common preventable cause of mental retardation in the world today. If the foetus and developing children in a community are not provided with sufficient quantities of iodine, the entire population will have decreased intelligence quotient (IQ), impaired motor function and hearing defect. The WHO estimates that there are still over 100 countries in our world with a significant problem with iodine deficiency. In areas of the world where iodine deficiency is found, up to 8% of the population may have deficient thyroid hormone production,

TSH hypersecretion and increased iodine trapping with goitre and raised plasma T<sub>3</sub>:T<sub>4</sub> ratio. Iodine deficiency *in utero* results in increased perinatal mortality, risk of abortion and congenital anomalies, neurological cretinism (development delay, deafness, spastic diplegia, squint) or myxoedematous cretinism (developmental delay and dwarfism). Iodine deficiency in the neonate leads to neonatal goitre, congenital hypothyroidism and hyperthyrotropinaemia. Iodine deficiency in childhood can manifest as retarded growth and development and goitrous hypothyroidism. In a recent meta-analysis of studies in China on the effects of iodine on intelligence, it was found that there was an IQ difference of 12.45 points in children living in iodine deficient areas as compared to those living in iodine sufficient areas. Neonatal serum TSH is included by WHO, UNICEF and ICCIDD in 1994 as one of the indicators for iodine deficiency disorders. If 3–19.9% of the neonatal TSH values exceed 10 mIU/L, mild iodine deficiency exists in that community. Regional differences in the incidence of congenital hypothyroidism could be due to differences in population iodine intake. The prevalence of goitre in the childhood community is also an indicator of iodine nutrition status. Iodination of salt supplies can effectively reduce the prevalence of this condition.

### Congenital Hypothyroidism

Apart from the rare genetic causes of thyroid dysgenesis, the causes of thyroid dysgenesis in which thyroid tissue may be absent (aplastic), deficient (hypoplastic) or abnormally sited (ectopic) are unknown but affect about 1 in 3,600 of all newborns and more commonly affect female infants. Dyshormonogenesis (inborn errors of thyroid hormone biosynthesis) accounts for about 10% of all cases of congenital hypothyroidism, i.e. 1 in 40,000. These autosomal recessively inherited disorders may present with goitre.

*Clinical features:* The diagnosis of severe congenital hypothyroidism should not be difficult. Indeed, the manifestations are present within a few days of birth. The presenting symptoms which are usually mild consist of feeding difficulties, skin mottling, noisy respiration and constipation. The undue prolongation of 'physiological jaundice' should always arouse the suspicion of hypothyroidism. The appearance of the infants is typical if they remain undiagnosed after 3–4 months of age. The facial features are coarse with often a wrinkled forehead and low hairline. The posterior fontanelle remains patent in early infancy. The hair may be dry and scanty. The large myxoedematous tongue protrudes from the mouth and interferes with feeding and breathing (Fig. 21.2). The cry has a characteristic hoarseness. The neck appears short due to the presence of myxoedematous pads of fat above the clavicles. The skin, especially over the face and extremities, feels dry, thick and cold. An umbilical hernia is



**Fig. 21.2:** Sporadic cretin aged 4 months. Note coarse features, large myxoedematous tongue and umbilical hernia

common. The hands and fingers are broad and stumpy. The hypothyroid infant is frequently apathetic and uninterested in his surroundings. As time goes by, psychomotor retardation becomes obvious and partially irreversible. Patients with Pendred syndrome have sensorineural hearing deficit in addition to hypothyroidism.

However, most infants with congenital hypothyroidism are born with few symptoms or signs. None the less, the marked delay in diagnosis so commonly encountered is unnecessary and it results often in avoidable intellectual impairment. The possibility of hypothyroidism should be considered in every infant or child in whom growth is retarded. Most cases of congenital hypothyroidism are diagnosed by neonatal screening by detection of increased TSH concentrations in Guthrie card blood spots, but cases with delayed rise in TSH will be missed.

In the undetected or untreated child, the body proportions remain infantile with long trunk and short legs. A tendency to stand with exaggerated lumbar lordosis and slightly flexed hips and knees is common. The anterior fontanelle is late in closing and the posterior fontanelle remains patent. The deciduous teeth are slow in erupting and radiographs may show defects in the enamel. The face and hands are frequently mildly myxoedematous and the cerebral activities are slow and sluggish. The mandible is often underdeveloped and the nasolabial configuration may be obviously that of a much younger child. The deep tendon reflexes are sometimes exaggerated with slow relaxation and there may be mild ataxia.

### *Juvenile Hypothyroidism*

Short stature is one of the only two invariable findings in hypothyroidism. The ratio of the U/L skeletal segment is

also abnormal (infantile) in hypothyroid children. The lower segment is the distance from the top of the symphysis pubis to the ground; the upper segment is obtained by subtracting the lower segment from the total height. The mean body U/L ratio is about 1.7 at birth, 1.3 at 3 years and 1.1 after 7 years of age. Hypothyroid children have an unduly long upper segment due to their short legs. Patients are lethargic and have waxy complexion, dry skin and coarse hair. Constipation and cold intolerance are common. Sexual development is often delayed. Rarely in some children with severe hypothyroidism, precocious sexual development can occur but the underlying mechanism is unknown. The sella turcica is enlarged and serum prolactin and FSH levels are elevated. Early sexual development will regress when the hypothyroid state is alleviated by treatment.

Delayed ossification to a more severe degree than that retardation in linear growth is the other constant finding in hypothyroidism. The assessment of bone age is based on radiographs of various epiphyseal areas, chosen according to the child's age, and their comparison with an ossification chart showing the normal ages at which the different centres should ossify (Fig. 21.1). Dysgenesis of the epiphyses is pathognomonic of hypothyroidism. It may be florid at one area and absent at another, so that radiographs should always be taken of several areas of the skeleton. In some cases dysgenesis only appears after thyroid treatment has been started, but then only in those ossification centres which should have appeared in the normal child before that age. The presence of dysgenesis indicates that that hypothyroid state existed before the affected centre would be normally due to ossify and it permits an assessment of the age, foetal or postnatal, at which the hypothyroidism developed. The characteristic X-ray appearance is of a misshapen epiphysis with irregular or fluffy margins and a fragmented or stippled appearance (Fig. 21.3). In older children, skeletal maturations are assessed with an X-ray of the nondominant hand and wrist using the Greulich and Pyle or Tanner-Whitehouse skeletal atlas. In the great majority of cases of hypothyroidism, measurements of the linear height, the upper and lower segments, and a few well chosen radiographs will establish or exclude the diagnosis of hypothyroidism beyond doubt. They will also determine the age of onset of the hypothyroid state.

### *Investigations*

The circulating free thyroxine ( $ft_4$ ) and free tri-iodothyronine levels ( $ft_3$ ) are low. A particularly sensitive biochemical test for hypothyroidism lies in measurement of the serum TSH using a suprasensitive assay. The TSH level (normal range  $<0.5$  to  $5.5$  mIU/L) is markedly raised (above  $50$  mIU/L) in primary hypothyroidism, whereas it will be low in pituitary hypothyroidism. In countries where screening for congenital



**Fig. 21.3:** Epiphyseal dysgenesis in femoral heads. Note stippling and fragmented appearance

hypothyroidism is carried out, neonates with a serum TSH  $> 40$  mIU/L or between 20 and 40 mIU/L on two occasions in the confirmatory samples will be regarded as suffering from primary hypothyroidism. A test of the TSH response to TRH given intravenously in a dose of  $10 \mu\text{g}/\text{kg}$  is rarely necessary except in neonates with persistent mild elevation of serum TSH levels. Serum thyroglobulin level is low in thyroglobulin gene defect or thyroid agenesis but is elevated in patients with organification disorders and TSH receptor defects. In babies with congenital hypothyroidism, X-ray of the knee and ankles should be done to assess skeletal maturity. Thus foetal hypothyroidism can be presumed in the full-term baby if the upper tibial or lower femoral epiphyses (which normally ossify at 36 weeks gestation) are absent or if they show epiphyseal dysgenesis.

Radioactive iodine (RAI) test is never necessary to establish the diagnosis of hypothyroidism, but it can be used to provide information about the pathogenesis. With the exception of iodide transport defects, patients with dysmorphogenesis have increased RAI uptake, with the thyroid gland in the normal position. Patients with thyroid peroxidase defect, Pendred syndrome and mutations in dual oxidase gene *DUOX2* have excessive discharge of RAI to perchlorate after its uptake into the thyroid gland. For the detection and location of thyroid activity in congenital hypothyroidism,  $^{123}\text{I}$  or  $^{99\text{m}}\text{Tc}$  can be safely given followed by scanning of the neck for radioactivity. Absent or decreased uptake in the neck is suggestive of thyroid dysgenesis and activity in the lingual location suggests an ectopic gland. Ultrasound examination of the thyroid gland is often helpful. Absence of radionuclide uptake in the presence of ectopic thyroid gland on ultrasound is suggestive of an iodine trapping defect.

### Neonatal Screening for Congenital Hypothyroidism

Irreversible brain damage is a common sequel to a delayed clinical diagnosis and treatment of congenital hypothyroidism.

Newborn screening for congenital hypothyroidism has been highly successful in improving the prognosis for mental development in hypothyroid neonates. The incidence of congenital hypothyroidism has been reported to be in the region of 1 in 3,600. Thyroid agenesis, hypoplasia or ectopic thyroid gland accounts for 80% of the cases of congenital hypothyroidism. 10% of the cases are due to inborn errors of thyroid hormone biosynthesis. Congenital hypothyroidism due to pituitary or hypothalamic dysfunction has an incidence of 1:25,000 births. Screening is usually carried out between the third day and seventh day of life. In Europe and Britain, the favoured technique is by RIA or more commonly enzyme-linked immunosorbent assay (ELISA) of TSH levels on dried filter paper blood spots obtained by heel stab. It involves an extremely low recall rate for repeat tests but is unable to detect the rare cases of secondary (pituitary) hypothyroidism. This disadvantage does not apply to measurement of  $\text{T}_4$  levels followed by TSH assay which is confined to specimens with low  $\text{T}_4$  values. This latter method is favoured by some American centres. While both methods are highly reliable, it is essential that infants with results in the hypothyroid range have confirmatory tests which should include clinical assessment, TSH assays, quantitative measurements of  $\text{T}_4$  and  $\text{T}_3$ , and assessment of bone maturation by X-ray of the knee. Infants are missed despite newborn thyroid screening programmes due to human error or problems in the infrastructure of the screening programmes. Treatment should be started as early as possible. The incidence rate of congenital hypothyroidism has been noticed to be rising in the United States and thyroid-blocking antibodies, maternal ingestion of antithyroid drugs (ATDs), iodine deficiency or excess have not been found to be contributing factors. It is possible that transient hypothyroidism and hyperthyrotropinaemia are being misclassified as cases of true congenital hypothyroidism.

Physiological hypothyroxinaemia is common in premature infants and significant hypothyroxinaemia occurs in 15–20% of extreme low birth weight (ELBW) babies and 5–10% of very low birth weight (VLBW) neonates. Also transient primary hypothyroidism occurs in 0.41% of VLBW infants and transient secondary hypothyroidism can occur in up to 10% of VLBW newborns. Non-thyroidal illness syndrome is common in VLBW neonates due to their stormy postnatal course. All these factors need to be taken into account to plan for screening for congenital hypothyroidism in premature infants. The Clinical and Laboratory Standards Institute recommends collection of blood spot specimen from premature neonates on admission to the neonatal intensive care unit or special care baby unit, a repeat specimen at 48–72 hours and a final sample at 28 days of life or on discharge whichever comes first.

### Treatment

The drug of choice for the treatment of hypothyroidism is L-thyroxine sodium. In infants a daily dose of 10 µg/kg up to a maximum of 50 µg daily should be given. By 5 years of age the dose should reach 75 µg daily and in adolescents the adult dose of between 100 and 150 µg daily is required and the dose should be guided by clinical response, growth and skeletal maturation assessment, and measurements of plasma T<sub>4</sub> and TSH. The maintenance dose level is that which permits linear growth to proceed at a normal rate and does not leave the bone age retarded. The dose of thyroxine should be adjusted to maintain the serum fT<sub>4</sub> in the upper normal range. Serum TSH levels may be normal or mildly elevated in adequately treated children. It is undesirable to permit the bone age to advance beyond the chronological age. Treatment must be regularly monitored every 2–3 months in the first 2 years of life and the frequency of spaced out when the children are older. Thyroxine has a half-life of 7 days and iron, mineral supplements, soya and dietary fibre can affect its absorption.

### Prognosis

The somatic response to adequate treatment before 3 months of age is invariably good but in some cases mild defects in hearing, speech and coordination persist despite having a normal IQ. Factors affecting outcome include the severity of congenital hypothyroidism, adequacy of thyroid hormone replacement in early life and the social economic background of the family. Despite treatment, world literature reports a decline of 0.5 SD in IQ in treated children who may show a variety of deficits of neuromotor, language, visuospatial, memory and attention skills which can persist into adolescence. Reconfirmation of the diagnosis by interruption of treatment should be performed at 3 years of age especially in children who were diagnosed to have congenital hypothyroidism but with a thyroid gland shown to be in the normal location by radionuclide scan. Lifelong treatment is required for patients with permanent congenital hypothyroidism.

### Autoimmune Thyroiditis (Hashimoto Thyroiditis)

Autoimmune thyroiditis is the most common cause of hypothyroidism in childhood. It is one of the best examples of an organ-specific autoimmunity and the immunological phenomena are usually confined to the thyroid gland. It is caused by an interaction of multiple genetic and environmental factors like infection and dietary iodine intake. The outstanding feature is infiltration of the thyroid by lymphocytes, plasma cells and reticular cells. Hyperplasia of the epithelial cells is commonly seen. In more advanced cases the epithelial cells show degenerative changes and there

may be extensive fibrosis with final destruction of the gland. Occasionally autoimmune thyroid disease may be associated with other autoimmune endocrine gland dysfunction as part of the autoimmune polyendocrine syndrome, including diabetes mellitus, adrenal insufficiency, candidiasis, hypoparathyroidism and pernicious anaemia.

*Clinical features:* In most children, the only sign is goitre and the onset of the disorder is usually insidious. It rarely has the firm, rubbery consistency so typical of the adult form of the disease. Presentation is usually with euthyroid goitre but in up to 10% of the cases, particularly in adolescence, there may be signs of thyrotoxicosis. Only a minority of affected children go on to develop hypothyroidism but it is important to monitor for signs of this state in every case as the onset of hypothyroidism is insidious and may be missed. The patient may have weight gain, slowing of growth, cold intolerance, constipation and deteriorating school performance. In adolescent patients, there may be delayed puberty or rarely precocious puberty. Hypothyroidism is diagnosed by a low or normal total or free thyroxine level together with elevated TSH concentrating (>10 mU/L). The classical antithyroglobulin and thyroid antimicrosomal antibodies titres are markedly elevated.

### Treatment

Thyroxine should be prescribed when the child is hypothyroid (TSH > 10 mIU/L) to suppress the excess secretion of pituitary TSH and to diminish the size of the goitre. These children should be kept under prolonged medical supervision because some later develop other autoimmune diseases.

### Hyperthyroidism

In contrast to hypothyroidism, thyrotoxicosis is a less common disorder in childhood. It usually takes the form of Graves' disease with diffuse thyroid enlargement and thyrotoxic ophthalmopathy. The incidence varies from 0.1 per 100,000 in young children to 14 per 100,000 among adolescents in some countries. About 35% of monozygotic twins as compared to 3% of dizygotic twins have been found to be concordant for Graves' disease suggesting the importance of genetic relative to the environmental factors (stress and smoking) in disease susceptibility. The HLA-DRB1 locus and A-G polymorphism of exon 1 of the cytotoxic T-lymphocyte-associated antigen-4 (CTLA-4) have been found to be associated with Graves' disease. Association between autoimmune thyroid disease with polymorphisms of the genes of tumour necrosis factor receptor super family member 5 (TNFRSF5), vitamin D receptor (VDR), thyroid peroxidase (TPO) and Pendred syndrome (SLC26A4) have been reported but not always replicated by others. Chromosomal regions (5q31, 14q31, 20q11) linked to

autoimmune thyroid disease have been identified by linkage analysis using the genome scan approach.

About 85–95% of cases of hyperthyroidism are due to Graves' disease and other causes include thyroiditis, hyper-functioning thyroid adenoma, germ-line activating TSH receptor mutation, McCune Albright syndrome, pituitary resistance to thyroid hormone and iodine induced hyperthyroidism.

### Clinical Features

The disease is more common in girls and rare before the age of 7 years. The parents may bring their child for medical advice with a variety of symptoms, such as irritability, fidgetiness, deterioration in school performance, loss of weight in spite of good appetite, excessive sweating, palpitations or nervousness. The child looks thin, and often startled due to her stare and wide palpebral fissures. There may be obvious exophthalmos (Fig. 21.4). Other eye signs include lid retraction, lid lag and ophthalmoplegia. There may be conjunctival injection because of exposure due to the proptosis. The skin will be flushed, warm and moist. A fine tremor of the outstretched fingers is common. The abnormal cardiovascular signs in the child include sinus tachycardia, raised systolic blood pressure and a large pulse pressure. The thyroid gland is visibly enlarged and feels soft. A bruit may be audible over the gland. Emotional liability is frequently very obvious. Menstruation may be delayed or irregular in untreated adolescent girls and growth acceleration is commonly seen at diagnosis. Neuropsychiatric complications include attention deficit, emotional liability, delusion and



**Fig. 21.4:** Thyrotoxicosis showing exophthalmos, lid retraction and goitre

thyrotoxic autoimmune encephalopathy presenting with profound personality change, bizarre motor automatism and seizures. Thyrotoxic periodic paralysis is rare in Caucasians but occurs in 2% of Chinese and Japanese thyrotoxic patients with a strong male predominance.

### Diagnosis

This is usually obvious on simple clinical observation. The most reliable biochemical feature is an elevated total and free serum  $T_3$  and  $T_4$  levels with suppressed TSH documented with a suprasensitive TSH assay. Both thyroid-stimulating antibody (TSAb) and thyroid-blocking antibody (TBAb) epitopes are close together and are both detected in the commercially available thyroid-binding inhibiting immunoglobulin (TBII) assays. TSAb bioassays are limited to specialised centres. TBII is disease-specific and are never present in normal euthyroid individuals. TBII is present in 80–90% of children with Graves' disease. ELISA assays for human auto-antibodies against thyroid-stimulating hormone receptor (TRAb) are also available as commercial assay kits. The antithyroglobulin and thyroid antimicrosomal antibodies are present in 68% of paediatric patients.

### Treatment

A trial of medical treatment with antithyroid drug (ATD) should always be made with the objective of rendering the patient euthyroid for 2 years before drug therapy is withdrawn. Carbimazole (0.5 mg/kg per day in two divided doses) and methimazole (10 mg carbimazole = 6 mg methimazole) are the drugs of choice. Propylthiouracil should no longer be used for the treatment of thyrotoxicosis in children because between 1970 and 1997, 34 of the 48 adverse events reported on ATD received by the Food and Drug Administration (FDA) of USA were related to PTU and the risk of PTU-induced liver failure leading to liver transplantation is estimated to be 1:4,000. After treating children for about 4 weeks, the dose can often be reduced according to the clinical state of the child and the  $T_4$  and  $T_3$  levels. An alternative approach would be the block-replace regime by maintaining the same suppressive doses of thionamides but adding a suitable replacement dose of thyroxine daily to maintain the serum  $T_4$  in the normal range. The advantage of this regime is the lower risk of fluctuations of thyroid hormone levels and fewer blood tests in the children under treatment. A recent meta-analysis revealed higher adverse events in adult thyrotoxic patients on block-replace regime as compared to those on titration regime with no difference in relapse rate and the optimum duration of treatment is 12–18 months. Another large study from Japan reported that the rate of agranulocytosis and neutropenia was 1.58% in the high ATD dose group versus 0.47% in the low



dose group. Based on these adult studies, it would be prudent for children with thyrotoxicosis to be treated with the lowest possible therapeutic dose of carbimazole or methimazole (0.5 mg/kg per day) initially and to titrate ATD therapy (0.2–0.4 mg/kg per day) to maintain the  $fT_4$  in the upper range of normal. The remission rate following medical therapy for juvenile thyrotoxicosis has been disappointing, being less than 20% in young children and about 30% in adolescents after 2 years of treatment. Pubertal adolescents with a small goitre, a relatively normal body weight and not excessively high circulating thyroid hormone level at diagnosis, have a higher chance of spontaneous remission. A high iodine intake increases the risk of relapse. In patients with multiple relapses, surgery or thyroid ablation with RAI should be considered. Recent studies have not found an increased risk of thyroid and extra-thyroidal cancer after radio-iodine treatment in patients older than 18 years of age. At the start of antithyroid treatment, the sympathetic overstimulation can be controlled with propranolol 2 mg/kg per day in two or three divided doses. Parents must be reminded that all the ATDs can cause toxic effects, e.g. rashes, agranulocytosis and aplastic anaemia.

### Transient Neonatal Thyrotoxicosis

There have been a considerable number of instances in which women who have or have had thyrotoxicosis, given birth to infants with the unmistakable signs of hyperthyroidism in the neonatal period. The infants are restless, agitated, excessively hungry and they exhibit warm, moist flushed skin, tachycardia (190–220 per minute), tachypnoea, exophthalmos and goitre (Fig. 21.5). The diagnosis has been made antenatally due to foetal tachycardia. Some mothers have been previously treated by partial thyroidectomy; others have received thyroid-blocking drugs during pregnancy. When the mother is thyrotoxic and not on ATDs up to the time of delivery, the hyperthyroid state is present in the infant from birth. If the mother has been rendered euthyroid by drugs and ATD therapy is continued until the time of delivery, neonatal thyrotoxicosis does not develop for some days because the thyroid gland is suppressed *in utero* and during the infant's first day of life.

There is good evidence that neonatal Graves' disease is caused by the transfer of maternal TSABs/thyroid-stimulating immunoglobulins (TSIs) across the placenta from mother to foetus. The presence of such immunoglobulins in the mother and infant at the same time has been demonstrated both by bioassay techniques and the radioreceptor assay method. The TSIs disappear from the infant's blood after about 3 months, so that the disorder is a temporary one. Diagnosis in the neonate is confirmed by demonstrating increased levels of total and free  $T_4$  and  $T_3$  and suppressed levels of TSH.



Fig. 21.5: Neonatal thyrotoxicosis

The degree of thyrotoxicosis can be alarmingly severe and prompt treatment of the newborn infant is essential. Treatment can be started with potassium iodide 2–5 mg thrice daily and propranolol 0.5 mg/kg per day in two divided doses. Carbimazole should be started in a dose of 0.5 mg/kg per day in two divided doses and adjusted based on the circulating  $T_4$  and  $T_3$  levels. It is only necessary to continue antithyroid medication for 6–12 weeks. Supportive treatment with digoxin and diuretics is rarely required and only if congestive heart failure is present.

### PARATHYROID GLANDS

Primary disorders of the parathyroid glands are exceedingly rare in paediatric practice. Much has been learned about the molecular structure and physiological activities of parathyroid hormone (PTH) in recent years and circulating PTH can be measured by RIA. PTH increases renal tubular calcium absorption and phosphate excretion, and intestinal calcium absorption. PTH also maintains serum calcium levels by stimulating osteoclastic bone resorption. It is hardly possible to consider the actions of PTH without consideration of calcitonin. Calcitonin is also a polypeptide and is secreted from the parafollicular 'C' cells of the thyroid gland. It inhibits the resorption of bone and acts as a physiological antagonist to PTH, causing hypocalcaemia. The only disorder associated with excessive calcitonin production is medullary thyroid carcinoma which may occur as part of multiple endocrine neoplasia type IIb (MEN IIb) caused by mutations in the RET proto-oncogene.

### Hypoparathyroidism

Hypoparathyroidism may occur after thyroid or parathyroid surgery or rarely radiation damage. In Asia and the

Mediterranean basin, hypoparathyroidism can result from haemosiderosis in transfusion-dependent thalassaemia major patients. A rare autoimmune polyendocrine syndrome due to mutations in the autoimmune regulator gene (AIRE) can result in hypoadrenalism which develops in childhood and is associated later with hypoadrenocorticism, and sometimes with steatorrhoea, pernicious anaemia, diabetes mellitus or elevated sweat electrolytes; moniliasis frequently precedes the endocrine manifestations. Rarely hypoparathyroidism can result from mitochondrial cytopathy. Apart from transient neonatal hypoparathyroidism due to maternal parathyroid disease, congenital hypoparathyroidism can be due to dysgenesis of the parathyroid gland, familial forms of disease (autosomal recessive, autosomal dominant, X-linked recessive), heterozygous gain-of-function mutations of the calcium-sensing receptor gene (CASR) or the DiGeorge syndrome (thymus hypoplasia, hypoparathyroidism, malformations of the outflow tracts of the heart) due to microdeletion of chromosome 22q11. Familial hypoparathyroidism may be associated with sensorineural deafness and renal anomalies (haploinsufficiency of GATA3).

### *Clinical Features*

The diagnosis of hypoparathyroidism is not difficult when a child presents with recurrent tetany. Other symptoms include paraesthesia ("pins and needles"), muscle cramps and carpedal spasm. Chvostek and Trousseau signs may be elicited. More often the outstanding feature is the presence of recurrent convulsions when an erroneous diagnosis of epilepsy may easily be made. Newborn infants with hypoparathyroidism presents with jitteriness or convulsions. Some affected children have also been mentally retarded and intracerebral calcification may occur. Useful diagnostic clues are delay in the second dentition and defective enamel, ectodermal dysplasia and deformed nails, loss of hair, and moniliasis in the mouth or nails. Cataract develops later in 50% of cases. The characteristic biochemical changes are a low serum calcium (below 2.25 mmol/L) and raised serum phosphate (above 2.25 mmol/L) and normal serum alkaline phosphatase and low PTH levels by RIA in the absence of rickets, renal disease and steatorrhoea. The urine calcium concentration is low but hypercalciuria is present if the patient has a gain of function mutation of CASR.

Pseudohypoparathyroidism gives rise to a very similar clinical presentation, hypocalcaemia and hyperphosphataemia, but in addition, some patients have features of Albright hereditary osteodystrophy (AHO), a stocky figure with dwarfism and a rounded face, brachydactyly with shortening of the metacarpals and metatarsals of the first, fourth and fifth fingers and toes, subcutaneous calcification, developmental delay and obesity. Pseudohypoparathyroidism type 1a is

due to maternal transmission of GNAS1 mutation. The serum PTH levels are markedly elevated in the presence of hypocalcaemia, hyperphosphataemia and the phosphaturic, and cyclic adenosine monophosphate (CAMP) responses to PTH are blunted. The biochemical abnormalities usually present at a mean age of 8 years.

### *Treatment*

The immediate treatment for tetany is a slow intravenous injection of 10% calcium gluconate, 0.3 ml/kg after dilution over several minutes, repeated every few hours as necessary. For long-term treatment, alfa-calcidol (1 $\alpha$ -hydroxyvitamin D<sub>3</sub>; 1 $\alpha$ -OHD<sub>3</sub>) 50–100 ng/kg or calcitriol (1,25-dihydroxyvitamin D 15 ng/kg per day) are preferred due to their shorter half-life. The dosage of the vitamin D should be adjusted to maintain the serum calcium in the low normal range without tetany or inducing hypercalciuria (spot urine calcium to creatinine ratio >0.7 mmol/mmol). The patient should be monitored for the development of subcutaneous calcification, nephrocalcinosis and intracranial calcification.

### **Hyperparathyroidism**

Hypercalcaemia due to adenoma or hyperplasia of the parathyroid glands are very rare in childhood. Neonatal primary hyperparathyroidism is caused by homozygous or compounded heterozygous mutations of the CASR and is associated with hypotonia, anorexia, respiratory distress, dehydration and a high mortality. Urgent parathyroidectomy is required. In older children, parathyroid tumour leading to hyperparathyroidism can be associated with multiple endocrine neoplasia syndrome type I (parathyroid, pancreatic, pituitary tumours due to mutation in MEN I gene) or multiple endocrine neoplasia type II (MTC, pheochromocytoma, parathyroid tumour due to mutations in the RET proto-oncogene).

### *Clinical Features*

In older children with hyperparathyroidism, bone pains and muscular weakness are the first symptoms. Peptic ulceration is unduly frequent in these patients. Anorexia, polyuria, polydipsia, vomiting, and severe constipation are common and attributable to the hypercalcaemia. The bone changes of osteitis fibrosa cystica are found. These include osteoporosis with patches of osteosclerosis. This produces a characteristic granular mottling or discrete rounded translucent areas in radiographs of the skull. Similar appearances are commonly found in the clavicles and iliac bones. Pathognomonic changes are frequently seen in the terminal phalanges of the hands where there is subperiosteal resorption of bone

with a crenellated appearance. The lamina dura, a dense line of alveolar bone surrounding the roots of the teeth, disappears. A giant-cell tumour (osteoclastoma) may appear as a multilocular cyst on radiographs of the mandible or long bones. Occasionally the presenting sign is a pathological fracture at the site of such a tumour. Hypercalcaemia can lead to nephrocalcinosis and renal calculi.

The most common biochemical features are a raised serum calcium level (over 2.74 mmol) and lowered serum phosphate (below 1 mmol). These values fluctuate and several estimations in the fasting patient at intervals may be required before the diagnosis is confirmed. The plasma alkaline phosphatase is frequently but not invariably raised. There is an increased urinary output of calcium (over 10 mmol/24 hours while on an ordinary diet). This observation should be followed by estimating the 24-hour calcium output on a low-calcium diet (120 mg/day); an output in excess of 4.5 mmol/24 hours is abnormal. When the kidneys have been severely damaged by nephrocalcinosis a high serum phosphate level may simulate secondary hyperparathyroidism. In children, however, renal osteodystrophy includes the changes of rickets which are rare in primary hyperparathyroidism. Furthermore, hypocalciuria is the rule in renal failure, but hypercalciuria usually persists in primary hyperparathyroidism even when there is severe renal damage.

### Treatment

Severe hypercalcaemia can be treated with intravenous fluid together with a loop diuretic and intravenous pamidronate infusion. The parathyroid tumour or hyperplastic glands should be removed surgically. Transient postoperative tetany is common and best treated with frequent intravenous doses of calcium gluconate. The results of operation are excellent provided the diagnosis has preceded irreversible damage to the kidneys.

## RICKETS

Rickets and osteomalacia are the consequences of decreased mineralisation of the bone osteoid caused by deficiencies of calcium, phosphate or vitamin D. Rickets in childhood can be due to nutritional deficiency of vitamin D from low intake or disordered absorption of fat soluble vitamins due to diseases of the hepatobiliary and gastrointestinal systems. The condition could also result from renal tubular disorders, X-linked familial hypophosphatemic rickets or to genetic defects like loss of function mutation of the genes for VDR or 25-hydroxyvitamin D3 1 $\alpha$ -hydroxylase (CYP27B1).

Nutritional rickets has emerged again as a paediatric health issue in several parts of the world. The vitamin D intake in most adults should be more than 200 IU per day and pregnant and lactating women would not meet the recommended daily

**Table 21.8:** Clinical features of rickets

- Expanded wrist, knee and ankle joints
- Rachitic rosary (swelling of costochondral junctions of the anterior chest cage)
- Bowing deformity of lower limbs in weight-bearing children
- Craniotabes
- Hypotonia, muscle weakness and delayed motor development
- Enamel hypoplasia and delayed tooth eruption

vitamin D intake without adequate exposure to sunlight. Dark skinned infants breastfed by vitamin D deficient mother who remain covered for cultural reasons, are particularly at risk. The American Academy of Paediatrics recommends that infants, children and adolescences should have a minimum daily vitamin D intake of 200 IU per day. Low calcium, high oxalate and phytate intake in Asian diet contribute to nutritional rickets. The clinical features of rickets are shown in Table 21.8.

The biochemical abnormalities in nutritional rickets include hypocalcaemia, hypophosphataemia, elevated PTH and alkaline phosphatase levels in the blood. The 25-hydroxyvitamin D level is less than 50 nmol/L. Radiologically, there is cupping and fraying of the metaphyses of the long bones and osteopenia. Treatment with vitamin D 3,000 IU daily for 3 months and maintenance of a daily vitamin D intake of 400 IU daily should be continued.

In most developed countries, the most common form of rickets is X-linked familial hypophosphataemia rickets which is caused by loss of function mutation of the phosphate-regulating gene with homologies to endopeptidases on the X-chromosome gene (PHEX). The incidence is reported to be 1 in 25,000. Apart from clinical features of rickets, these patients present with short stature, bone pain, joint stiffness, dental abscess but craniotabes and muscle weakness are not present. The clinical expression is variable and male patients are more severely affected than heterozygous females. Biochemical abnormalities include low normal serum calcium, low serum phosphate and elevated alkaline phosphatase levels. The serum PTH and vitamin D levels are normal but the 1,25(OH)<sub>2</sub>D<sub>3</sub> concentration is inappropriately low for the degree of hypophosphataemia. The urine calcium concentration is normal and there is no amino aciduria. The urine hydroxyproline is increased. Nephrocalcinosis is a common complication and is due to deposition of calcium and phosphate in the kidneys and it has been shown to have a stronger link with phosphate dosage and urine phosphate excretion. Treatment include phosphate supplement (not more than 70 mg/kg per day) and rocaltrol (20–60 ng/kg per day) and regular monitoring is required to avoid hypercalcaemia, hypercalciuria (calcium/creatinine ratio > 0.7 mmol/mmol) and nephrocalcinosis.

Autosomal dominant hypophosphataemic rickets is due to activating mutations of fibroblast growth factor 23 gene (FGF23) which prevents the degradation of FGF23. Hereditary hypophosphataemic rickets with hypercalciuria is due to loss of function in sodium-phosphate cotransporter type 2 gene (SLC34A3) and long-term phosphate supplement alone is adequate to treat these patients. Other causes of phosphaturic rickets include the Fanconi syndrome and other types of renal tubular acidosis, oncogenic osteomalacia and McCune Albright syndrome.

## THE GONADS

The development of the pituitary gland, the control of pubertal development and development of secondary sexual characteristics have already been described. Secretion of GnRH by GnRH neurons is inherently pulsatile. GABAergic receptors mediate inhibitory and NMDA receptors mediate facilitatory input. Oestradiol directly stimulates or inhibits GnRH gene expression under different conditions and the stimulation of GnRH and LH surge in mid-cycle by oestrogen seems to involve induction of progesterone receptors in the hypothalamus. Prolactin suppresses both hypothalamic and gonadotrope GnRH receptor expression. Hypothalamic endorphins suppress GnRH secretion and interleukins inhibit gonadotrophin release.

### Hypogonadism

Adolescents without signs of puberty by 13 years in girls and 14 years in boys, or failing to progress in the development of secondary sexual characteristics warrant further assessment. Primary amenorrhoea is defined by the absence of menstruation by 14 years of age in a girl with no secondary sexual characteristics or by 16 years in a girl with some development of secondary sexual characteristics. The causes of hypogonadism are shown in Table 21.9.

#### Clinical Features

With the exception of cryptorchidism and micropenis suggestive of congenital hypopituitarism, the features of hypogonadism in the male only become manifest after the time of normal puberty. Growth continues for an abnormally long period but at a slower growth rate due to delay in fusion of the epiphyses. There is a fall off in the growth velocity in hypogonadal adolescents and this pattern of growth is different from that seen in adolescents with constitutional delay in growth and puberty (CDGP). Children with CDGP grow at a normal rate below the third percentile and the onset of puberty is delayed. The bone age is frequently delayed by more than 2 years when compared to the chronological age. Both males and females with hypogonadism have a low U/L segment ratio. Clinicians should be aware of the clinical features of

**Table 21.9:** Causes of hypogonadism

<i>Hypogonadotropic hypogonadism</i>
<ul style="list-style-type: none"> <li>• Congenital defects in hypothalamic—hypophyseal formation associated with midline facial defects</li> <li>• Mutations in genes of pituitary transcription factors, GnRH receptor and gonadotrophin</li> <li>• Genetic hypothalamic defects (Kallmann syndrome, Prader-Willi and Bardet-Biedl syndrome)</li> <li>• Acquired               <ul style="list-style-type: none"> <li>– Suprasellar tumours</li> <li>– Infiltrative disease</li> <li>– Damage from radiation, trauma, haemosiderosis, intracranial infection</li> </ul> </li> <li>• Functional hypothalamic hypogonadism               <ul style="list-style-type: none"> <li>– Drugs and contraceptive pills</li> <li>– Systemic illness and eating disorder</li> <li>– Exercise induced amenorrhoea in girls</li> <li>– Stress and cortisol excess</li> </ul> </li> </ul>
<i>Hypergonadotropic hypogonadism in girls</i>
<ul style="list-style-type: none"> <li>• Gonadal dysgenesis—Turner (45,X) and trisomy syndromes, WT1 mutations</li> <li>• Autoimmune ovarian failure</li> <li>• Damage by radiation, cytotoxic drugs and infection</li> <li>• Genetic causes due to mutations of SF1, gonadotrophin receptor gene, fragile X premutation, Noonan syndrome</li> </ul>
<i>Hypergonadotropic hypogonadism in males</i>
<ul style="list-style-type: none"> <li>• Klinefelter syndrome (47,XXY)</li> <li>• Damage from orchitis, radiation and chemotherapeutic agents</li> <li>• Noonan syndrome, cystic fibrosis and rare genetic causes</li> </ul>

**Table 21.10:** Investigations of hypogonadism

<ul style="list-style-type: none"> <li>• Serum LH, FSH, prolactin, oestradiol or testosterone levels</li> <li>• Morning cortisol, fT<sub>4</sub>, TSH concentrations</li> <li>• X-ray for bone age</li> <li>• Karyotype</li> <li>• GnRH/GnRH-analogue test to distinguish hypogonadotropic hypogonadism from CDGP</li> <li>• Combined pituitary stimulation test and MRI scan of the brain, hypothalamus and pituitary gland if indicated</li> </ul>
--

syndromes associated with hypogonadism like Prader-Willi, Noonan, Bardet-Biedl, Klinefelter and Turner syndromes. Gynaecomastia is usually seen in hypergonadotropic hypogonadism. Hypogonadotropic hypogonadism associated with anosmia is suggestive of Kallmann syndrome which can be inherited in the X-linked (KAL1 mutation) or autosomal recessive (FGFR1 mutation) fashion. Clinical evaluation should be done to exclude acquired hypogonadism (Table 21.9). Suggested investigations for hypogonadism are shown in Table 21.10.

#### Treatment

In adolescents with hypogonadism, induction of puberty should be started no later than 14 years in girls and 15

years in boys. The dose of oestrogen (2.5 µg of ethinyl oestradiol daily or premarin 0.3 mg alternate days) can be progressively increased over 2.5–3 years. Cyclical oestrogen and progestogen (medroxyprogesterone acetate 5–10 mg daily for 7–10 days of each monthly cycle) should be initiated when the dose of oestrogen has reached 15–20 µg of ethinyl oestradiol or 0.625 mg of premarin daily or when break through bleeding occurs. In boys, puberty can be induced by oral testosterone undecanoate or more commonly by monthly intramuscular injection of testosterone enanthate, starting from 50 mg per month and slowly increasing to 250 mg every month over a period of 3–4 years. Intramuscular testosterone can be associated with mood swings and cyclical aggression and depression. Testosterone subcutaneous implants can provide a much steady testosterone level over the months. It is now possible to restore menstruation and induce ovulation in females and induce puberty and spermatogenesis in males with hypogonadotropic hypogonadism by pulsatile administration of GnRH with a portable pump or by sequential treatment with parenteral human chorionic gonadotrophin and recombinant human FSH.

### Precocious Puberty

Pubertal development in girls have been reported to occur earlier in recent years in many populations but there has been a less dramatic change in the age of onset of menarche. The age of onset of puberty in boys has not advanced significantly in recent years. Precocious puberty is defined as breast development before the age of 7 years and menstruation before the age of 10 years in girls and testicular or penile enlargement before the age of 9 years in boys. The causes of precocious puberty are shown in Table 21.11.

#### Clinical Features

In premature thelarche, there is isolated development of the breasts without significant acceleration of growth or skeletal maturation or the development of other secondary sexual characteristics. The condition frequently occurs in the first 18 months of life. There may be fluctuations of the breast size but the condition is not progressive. Occasionally non-progressive breast development can occur in girls in the peripubertal age group (5–7 years of age) and the condition is sometimes referred to as thelarche variant but should be distinguished from the early stage of central precocious puberty. Premature adrenarche refers to early isolated development of sex hair without other signs of puberty. Premature adrenarche are more prevalent in African Americans and East Asian Indians. Care must be taken to exclude the possibility of late-onset congenital adrenal hyperplasia (CAH) or androgen-secreting tumour from the adrenal glands or gonads.

**Table 21.11:** Causes of precocious puberty

<i>Gonadotrophin dependent or central precocious puberty</i>
<ul style="list-style-type: none"> <li>• Idiopathic</li> <li>• Intracranial tumours: Hypothalamic hamartoma, pineal region tumour, tumour in posterior hypothalamus, germinoma, craniopharyngioma (rare), optic nerve glioma.</li> <li>• Cranial irradiation</li> <li>• Head trauma</li> <li>• Neurological disorders: Hydrocephaly, intracranial infection, cerebral palsy, epilepsy</li> <li>• Hypothyroidism</li> <li>• Neurofibromatosis type 1</li> </ul>
<i>Gonadotrophin independent sexual precocity</i>
<ul style="list-style-type: none"> <li>• McCune Albright syndrome</li> <li>• Familial testotoxicosis</li> </ul>
<i>Pseudoprecocious puberty</i>
<ul style="list-style-type: none"> <li>• Congenital adrenal hyperplasia</li> <li>• Oestrogen or androgen-secreting tumours from the gonads or adrenal glands</li> <li>• HCG-secreting tumour (boys)</li> <li>• Autonomously functioning ovarian cysts in girls</li> </ul>
<i>Incomplete precocious puberty</i>
<ul style="list-style-type: none"> <li>• Premature thelarche</li> <li>• Premature adrenarche</li> </ul>

Patients with true precocious puberty have rapid physical growth and advanced skeletal maturation. In addition to the development of secondary sexual characteristics, behavioural change like emotion liability and aggression may occur. The behaviour of children with precocious puberty is more appropriate to their chronological age rather than the degree of sexual development. Other changes include increased sebaceous gland secretion (greasy skin and hair), acne and body odour. Children with precocious puberty who are untreated usually have an increased U/L segment ratio. Most cases of precocious puberty in girls are idiopathic but about 5–10% of girls and 40% of boys with precocious puberty have an occult or known intracranial pathology.

Patients with the McCune Albright syndrome have the characteristic triad of irregular café-au-lait pigmentation, gonadotrophin independent sexual precocity and polyostotic fibrous dysplasia but sometimes, the complete triad is not present. The condition is due to a somatic activating mutation of the GNAS1 gene. The patients typically have breast development due to oestrogen production from an autonomously functioning ovarian cyst. When the cyst ruptures, menstruation occurs as a result of acute oestrogen withdrawal.

Familial testotoxicosis is inherited in an autosomal dominant male limited fashion. There is autosomal dominant presentation of early sexual development in males of the affected families. The condition manifests itself usually by 2–3 years of age and is due to activating mutations of the

lutetising hormone receptor gene. Females carrying the mutation will not develop precocious puberty. There is some seminiferous tubule development and spermatogenesis due to the high intratesticular concentrations of testosterone present in affected patients even though the gonadotrophin levels are suppressed.

A germ cell tumour producing HCG can lead to pseudoprecocious puberty in boys only. However, germ cell tumours can also cause true precocious puberty due to the location of the tumour in the posterior hypothalamus distorting the hypothalamic 'gonadostat'. An autonomously functioning ovarian cyst producing oestrogen can cause premature breast development. These cysts should be distinguished from juvenile granulosa tumours of the ovaries by serial ultrasound assessment. Persistence of cystic lesions with a significant solid component and persistent elevation of serum oestradiol concentration for more than 3 months should alert the doctor to the possibility of an ovarian tumour. CAH can cause isosexual pseudoprecocious puberty in boys and heterosexual pseudoprecocious puberty in girls (refer to subsequent section of this chapter). Differentiation of virilisation due to CAH from an adrenal tumour is important in virilised patients.

### Investigations

Suggested investigations and interpretation of the hormonal tests are shown in Tables 21.12 and 21.13 respectively.

### Treatment

Patients with precocious puberty are at risk of being short as adults due to early skeletal maturation. The suggested indications for GnRH-analogue treatment for children with central precocious puberty are shown in Table 21.14. Treatment with a long-acting GnRH analogue given either monthly or 3 monthly offers the greatest advantage for those children in whom the onset of puberty occurs at a very early age (<6 years), those who demonstrate rapidly accelerating bone age and those with lower genetic height potential or those with the largest difference between the target and

**Table 21.12:** Investigations for precocious puberty

- Baseline oestradiol or testosterone, LH, FSH levels and the LH and FSH response to GnRH (2.5 µg/kg intravenously)
- X-ray for bone age
- Ultrasound examination of the pelvis in girls for ovarian volume and cysts, uterine size, and cervix to uterus ratio
- Magnetic resonance imaging of the brain
- Investigations for involvement of other pituitary hormones where indicated: FT<sub>4</sub>, TSH, prolactin levels, and cortisol and GH reserve

predicted height. It is important for clinicians to be aware that slowing progressive variants of precocious puberty exist and these children do not need treatment. Such patients have a slow tempo of pubertal development, no significant skeletal maturation and they have a satisfactory predicted adult height. When GnRH-analogue treatment is stopped at 11–12 years of age, pubertal development returns. Fertility is not usually affected but treated girls may have a slight increased risk of developing polycystic ovary syndrome. Patients with gonadotrophin independent precocious puberty require treatment with an aromatase inhibitor in girls or drugs that blocks testosterone biosynthesis in boys. Treatment with tamoxifen and letrozole has been shown to significantly decrease the growth rate, bone age advancement and progress of puberty in girls with McCune Albright syndrome. However, an increased ovarian volume with treatment in these girls has raised some concern. A combination of spironolactone and testolactone has been used to treat boys with familial testotoxicosis with some success. The underlying condition leading to pseudoprecocious puberty should be managed appropriately.

## ADRENAL GLAND

Adrenal steroidogenesis is controlled by a number of cytochrome P450 and hydroxysteroid dehydrogenase enzymes (Fig. 21.6). The adrenal cortex produces cortisol, mineralocorticoid (aldosterone) and sex steroids (androgens) whereas the adrenal medulla secretes adrenaline, noradrenaline, catecholamines and dopamine.

**Table 21.13:** Sex steroids and gonadotrophins in precocious puberty

	<i>E2/testosterone</i>	<i>LH (basal)</i>	<i>LH (peak)</i>	<i>FSH (peak)</i>
Premature thelarche (girls)	prepub	< 0.5 IU/L	prepub	↑↑↑
Early precocious puberty	prepub or ↑	< 0.5 IU/L	< 7 IU/L	↑↑
Established precocious puberty	↑ – ↑↑	> 0.6 IU/L	> 9.6 IU/L in boys > 7 IU*/L in girls	↑
Pseudoprecocious puberty	↑ – ↑↑	↓↓	↓↓	↓↓
Gonadotrophin independent sexual precocity	prepub – ↑	↓↓	↓↓	
HCG tumour (boys)	↑	slight ↑	no change	↓↓

\* The levels of LH are for reference only and the cut-off levels for definition of puberty depends on the performance of the immunoassay used in the laboratory

## Cushing's Syndrome

Cushing's syndrome in children is commonly iatrogenic in nature due to steroids given by the oral, topical or inhalational routes. Rarely steroid excess state can become manifest due to adrenal tumour, primary pigmented nodular adrenal disease, ectopic ACTH-secreting malignancy or Cushing's disease (ACTH-secreting pituitary adenoma). Apart from iatrogenic Cushing's syndrome, adrenal tumours account for 80% of Cushing's syndrome in children less than 7 years of

**Table 21.14:** Suggested indications for GnRH-analogue treatment for children with central precocious puberty

- Central precocious puberty with one or two signs of puberty occurring before 9 years in boys and before 6 years in girls but treatment after 6 years of age in girls should be individualised
- Pubertal GnRH-stimulated LH concentrations (peak LH or LH/FSH ratio)
- Rapidly progressive puberty (rapid statural growth, progression of secondary sexual characteristics and skeletal maturation) documented over 3–6 months
- Compromised predicted adult height (based on bone age) of less than 2 SD or demonstration of significant loss of height potential on follow-up assessment
- Psychological or behavioural reasons

Adapted from Carel JC, Eugster EA, Rogol A, et al. *Pediatrics*. 2009;123:e752

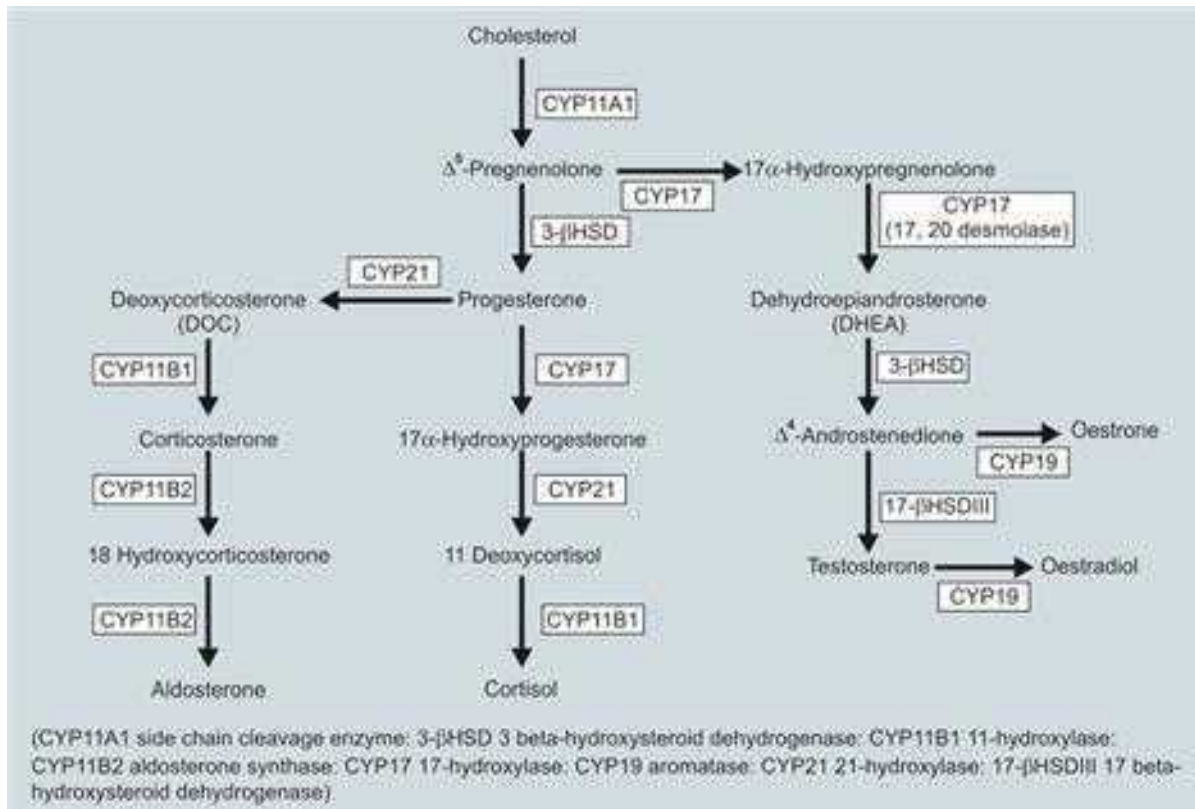
age and 40% are malignant. Pseudo-Cushingoid states can be due to stress, depression and alcoholism.

### Clinical Features

The clinical features of Cushing's syndrome result from the excessive secretion of adrenal hormones and are dominated by the effects of cortisol. Growth retardation, fatigue and emotional liability are common symptoms. Those due to an increased production of glucocorticoids include buffalo hump fat pad over the back of the neck, obesity, moon face, purple striae over abdomen, flanks and thighs, easy bruising, muscle wasting and weakness, osteoporosis, latent diabetes mellitus and polycythaemia (Figs 21.7A and B). Increased output of mineralocorticosteroids and aldosterone accounts for the hypertension and hypokalaemic alkalosis. Excessive secretion of androgens may cause hirsutism and clitoral enlargement in females, baldness and acne. These patients are, in addition, highly susceptible to infections.

### Diagnosis

In patients with Cushing's syndrome due to exogenous steroids given in excess (> 6–8 mg/m<sup>2</sup> per day of hydrocortisone equivalent), the endogenous secretion of glucocorticoids will be suppressed. Excessive doses of



**Fig. 21.6:** Flow diagram showing pathways of steroid metabolism



A



B

**Figs 21.7A and B:** (A) A child with Cushing's syndrome; (B) CT scan showing a large well-encapsulated tumour with calcification of the left adrenal gland

glucocorticoids like prednisolone or dexamethasone (1 mg prednisolone equivalent to 4 mg hydrocortisone and 1mg of dexamethasone is equivalent to 30 mg of hydrocortisone) will result in features of Cushing's syndrome but the morning plasma cortisol and 24-hour urine free cortisol and 17-oxogenic steroids will be suppressed. Endogenous excessive secretion of glucocorticoids due to an adrenal tumour or ACTH-secreting pituitary tumour will result in loss of diurnal cortisol rhythm with elevated morning and evening plasma cortisol levels and a midnight plasma cortisol of greater than 207 nmol/L is highly specific for the diagnosis of Cushing's syndrome. The urinary free cortisol will be elevated more than four times the upper limit of normal corrected for the creatinine level. Frequently the 24-hour

urinary oxogenic steroids concentration is also elevated. A plasma ACTH level is useful and measurable or elevated levels is suggestive of ACTH-dependent Cushing's disease or ectopic ACTH production. The change in plasma cortisol and urinary free cortisol levels to low dose (30  $\mu\text{g}/\text{kg}$  per day divided in four doses) and high dose (120  $\mu\text{g}/\text{kg}$  per day in four divided doses) dexamethasone suppression is a useful test. Failure of adrenocortical suppression by high dose dexamethasone is strongly suggestive of an adrenal tumour. In difficult cases, the corticotrophin-releasing hormone test and bilateral inferior petrosal sinus venous sampling may be required to localise a pituitary ACTH-secreting adenoma. Biochemical diagnosis must be complemented by MRI scan with gadolinium enhancement of the pituitary and adrenal glands.

### Treatment

Iatrogenic Cushing's syndrome should be managed by withdrawal of steroid therapy or to use a minimal effective dose or an alternate day regime if discontinuation of steroid treatment is not possible. A tumour of the adrenal gland should, of course, be excised when this is possible. In most cases of adrenal hyperplasia, a satisfactory result can only be obtained by total bilateral adrenalectomy followed by replacement therapy (as in Addison disease). Unfortunately, it appears that this treatment may be followed by the subsequent appearance of pituitary tumours and severe hyperpigmentation (Nelson syndrome). The prognosis of Cushing's syndrome when the cause is tumour will depend upon its nature (e.g. adrenal carcinoma), extent and removability. Pituitary Cushing's syndrome is best treated by trans-sphenoidal surgical removal of the pituitary adenoma. Reported recurrence rates after transphenoidal surgery in children varies from 42% to 78%. A serum cortisol less than 50 nmol/L at 0900 hour within 2 weeks of surgery is a good index of remission.

### Adrenal Insufficiency

Adrenal insufficiency can be caused by disorders involving the hypothalamus and pituitary gland (Table 21.1) or those affecting primarily the adrenal gland. The causes of primary adrenal insufficiency are shown in Table 21.15.

### Clinical Features

In the most common form of autoimmune polyendocrine syndrome, the children present with cutaneous candidiasis, hypoparathyroidism (tetany and convulsions) and adrenal insufficiency. Allgrove syndrome is characterised by alacrima, achalasia, ACTH-resistance and neurological symptoms. In the older child, the manifestations closely resemble those seen in the adult—extreme asthenia,



**Table 21.15:** Causes of adrenal insufficiency

<ul style="list-style-type: none"> <li>• DAX1 mutation</li> <li>• SF1 mutation</li> <li>• IMAGE syndrome</li> <li>• P450 oxidoreductase deficiency (<math>\pm</math> Antley-Bixler syndrome phenotype)</li> <li>• Adrenocorticotrophic hormone unresponsiveness</li> <li>• Familial glucocorticoid resistances</li> <li>• Autoimmune adrenal insufficiency (APS1 AIRE; APS2 HLADR3 CTLA-4)</li> <li>• X-linked adrenoleukodystrophy</li> <li>• Inherited defects of adrenal steroidogenesis</li> <li>• Mitochondrial cytopathy</li> <li>• Triple A syndrome (ALADIN-WD-repeat protein)</li> </ul>
<i>Acquired adrenal insufficiency</i>
<ul style="list-style-type: none"> <li>• Infections: Tuberculosis, fungal infection, CMV, HIV meningococcus, <i>Pseudomonas</i>, <i>E. coli</i></li> <li>• Haemorrhage/thrombosis: SLE, polyarteritis, antiphospholipid syndrome, anticoagulant therapy</li> <li>• Infiltration: Tumour, sarcoidosis, amyloidosis, haemosiderosis</li> <li>• Drugs: Cyproterone acetate, ketoconazole, aminoglutethimide, mitotane, rifampicin</li> </ul>

cachexia, hypotension and microcardia. Pigmentation of skin and mucous membranes tends to be less marked in children. Dangerous adrenal crises may occur, often precipitated by infections. Hypoglycaemic convulsions may first bring the child to the physicians.

In the congenital form of the disease, acute adrenal failure may develop with alarming rapidity during the neonatal period. Newborn infants with adrenal insufficiency frequently present with hypoglycaemia and prolonged neonatal jaundice. Increased skin pigmentation is also seen. Vomiting, diarrhoea and extreme dehydration can lead easily to an erroneous diagnosis such as pyloric stenosis, high intestinal obstruction or gastroenteritis. The pointer to adrenal insufficiency is the presence of abundant sodium and chloride in the urine, and hyponatremia, hyperkalaemia in the serum. Congenital adrenal insufficiency is due to a number of rare genetic disorders and the diagnosis and genetic analysis and management should be performed in a tertiary referral centre. Tuberculous adrenalitis is now a rare cause of primary adrenal insufficiency in childhood. Exogenous corticosteroid therapy can induce adrenal suppression in patients if used in dosages above the cortisol secretion rate for over 3 weeks.

### Diagnosis

During a crisis, characteristic blood chemical changes include low serum chloride and sodium, elevated serum potassium (with changes in the ECG) and hypoglycaemia. In the absence of a crisis the blood chemistry may not be grossly abnormal and more refined tests are necessary. In primary adrenal insufficiency, the plasma ACTH concentration will

be elevated. The early morning plasma cortisol level will be low and fails to rise in response to low dose Synacthen stimulation ( $1 \mu\text{g}/1.73 \text{ m}^2$  intravenously) or standard dose Synacthen test ( $250 \mu\text{g}$  intravenously). In neonates and young infants, a Synacthen test using a dose of  $1 \mu\text{g}/\text{kg}$  intravenously has been recommended. Failure of the plasma cortisol to increase by  $200 \text{ nmol/L}$  and reach to an absolute level of more than  $500 \text{ nmol/L}$  in response to Synacthen is suggestive of adrenal insufficiency. If secondary adrenal insufficiency is suspected, appropriate investigations of the hypothalamic pituitary axis like the glucagon stimulation test or insulin tolerance test should be performed.

In further assessment of the aetiology of primary adrenal insufficiency, recommended investigations include:

- Plasma very long chain fatty acids
- Auto-antibody levels against adrenal, thyroid, gastric parietal cell, islet cell
- Serum thyroid hormones, calcium, phosphate, vitamin B<sub>12</sub> and folate concentrations
- Recumbant and erect plasma renin activity, aldosterone, electrolytes and urine sodium concentrations to assess mineralocorticoid activity
- Plasma lactate
- Skeletal survey
- Appropriate molecular genetic diagnosis.

### Treatment

In the management of acute adrenal crisis, there should be adequate replacement of fluid, sodium and glucose, and hydrocortisone by the intravenous route. In situations of stress after an initial bolus of hydrocortisone intravenously, it has been suggested that the dose of hydrocortisone ( $25\text{--}30 \text{ mg}/\text{m}^2/\text{every 6 hours}$ ) be given by continuous infusion rather than by bolus. The usual oral replacement dose of hydrocortisone is  $8\text{--}10 \text{ mg}/\text{m}^2$  per day in divided doses and the fludrocortisone dosage is  $100\text{--}200 \mu\text{g}$  per day. If a child is unwell during an intercurrent illness, the oral hydrocortisone replacement dosage should be tripled until the child is better. Excessive replacement steroid dosage will stunt physical growth and should be avoided.

### Congenital Adrenal Hyperplasia

Deficiencies of the enzymes involved in adrenal steroidogenesis will lead to different varieties of CAH (Fig. 21.6).  $21\alpha$ -hydroxylase deficiency accounts for 95% of the cases of CAH seen in childhood and will be discussed in detail. The incidence varies from 1:15,000 to 1:20,000 births and is inherited in an autosomal recessive manner. The incidence of CAH has been reported to be higher in India, Philippines and South America.  $21\alpha$ -hydroxylase deficiency results from mutations of the CYP21B gene which is situated on

chromosome 6 in close proximity to the HLA genes. There is a reasonable genotype-phenotype correlation with drastic mutations causing salt-wasting 21 hydroxylase deficiency (21-OHD) and severe mutations leading to virilising form of the disease. Nonclassic form of 21 $\alpha$ -hydroxylase deficiency occurs if one of two mutations is mild and female patients present with premature adrenarche or hyperandrogenism in adolescence.

### Newborn Screening for Congenital Adrenal Hyperplasia

Salt-wasting form of CAH is a life-threatening disorder leading to circulatory collapse and disorder of sex development (DSD) in girls. In Sweden, the mortality rate of CAH without screening was 2.2% from 1969 to 1986. First-tier screening tests measure 17 $\alpha$ -OHP levels in dried blood spots collected on filter paper cards by enzyme-linked immunoassay or by time-resolved dissociation-enhanced lanthanide fluorescence immunoassay (DELFI). The serum 17 $\alpha$ -OHP levels in the newborn are affected by birth weight, gestational age and timing of the sample. Stratification of recall 17 $\alpha$ -OHP cut-off values according to birth weight categories and the use of second-tier screening of measuring 17 $\alpha$ -OHP by tandem mass spectrometry or molecular diagnosis have been used to improve the positive predictive value of the screening test. The cost-effectiveness of neonatal screening for CAH remains controversial.

#### Clinical Features

Male infants with 21 $\alpha$ -hydroxylase deficiency appear normal at birth apart from rather marked pigmentation of the scrotum. After a short time virilisation is revealed in the virilising form of 21-OHD by enlargement of the penis, growth of pubic hair, excessive muscular development and advanced skeletal maturation due to the action of the excess androgens. The testes, however, remain small and undeveloped. The increased stature ultimately gives way to short adult stature due to premature fusion of the epiphyses. In the salt wasting form of the disease, male patients present in a salt-losing crisis at the end of the first week or in the second week of life with vomiting, diarrhoea, severe dehydration and shock. The correct diagnosis is easy enough in the virilised female infant but in the male an erroneous diagnosis of pyloric stenosis, gastroenteritis or septicaemia is easily made. The serum sodium and chloride levels are reduced, and the serum potassium level is high with corresponding ECG changes. There is also metabolic acidosis, elevated serum urea and increased fractional excretion of sodium. The salt-losing form of 21-OHD accounts for 60–75% of cases. In all types of adrenal hyperplasia excessive skin pigmentation is common.

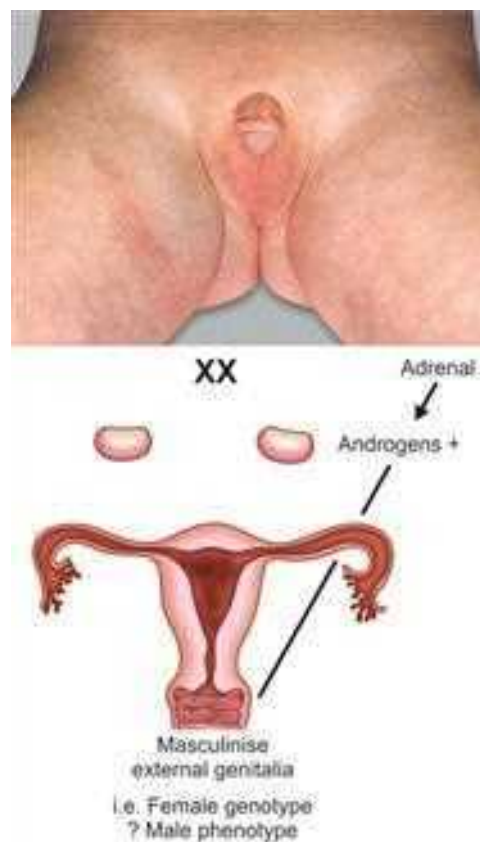


Fig. 21.8: Masculinisation of female genitalia due to congenital adrenal hyperplasia

In female infants, the excessive androgenic effects upon the foetus produce more striking and unwelcome changes. In mild cases there is marked clitoral enlargement. In an extensively virilised newborn female, there is marked clitoral enlargement, fusion of the labia majora and the vagina and urethra may enter a single common urogenital sinus (Fig. 21.8). An extensively virilised infant can readily be mistaken for a cryptorchid male. Similarly, females with drastic CYP21B mutations present in salt-losing crisis in the neonatal period. Without treatment, a girl with virilising 21-OHD becomes progressively masculinised with hirsutism, clitoromegaly, muscularity and advanced bone age.

#### Diagnosis

In countries where there is screening for CAH in the neonatal period, patients with the classical form but not necessarily the nonclassical form of 21-OHD will be identified. Biochemical confirmation of a clinically diagnosed case is shown by elevated plasma ACTH, 17 $\alpha$ -OHP, high plasma renin activity levels and low plasma cortisol and aldosterone levels in patients with salt-wasting 21-OHD. In simple virilising 21-OHD, the morning 17 $\alpha$ -OHP levels are high

but the plasma renin activity and serum electrolytes may be normal. Advanced skeletal maturation is seen in untreated or undertreated patients with classical 21-OHD. In a virilised female, chromosomal analysis and ultrasound examination of the pelvis for the presence of female internal genital organs are necessary.

### Treatment

Hydrocortisone is administered to children in a dose of 10–20 mg/m<sup>2</sup> per day divided into two or three doses. Patients are monitored by measuring serum electrolytes, plasma renin and 17 $\alpha$ -OHP levels every 3–4 months. In children and young adolescents growth velocity and bone age (annually) are followed over time to ensure that they are receiving the proper dose. In the salt-wasting form of CAH mineralocorticoid replacement is also necessary. 9 $\alpha$ -fludrocortisone in a dose of 0.05–0.2 mg daily orally is required with careful monitoring of blood pressure, plasma renin activity, serum and urine electrolytes. In addition, it is recommended that salt supplement of 3–5 mmol/kg per day be given to salt-losing 21-OHD patients in the first 2–3 years of life. Higher dosages of hydrocortisone is required in times of stress. In most virilised females who have been treated with suppressive glucocorticoids from an early age it is important to correct the external genitalia, by 2–6 months of age (recession clitoroplasty and feminising vaginoplasty). Vaginal dilatation is contraindicated in childhood. Examination of the genitalia should only be done to assess pubertal development or if under-treatment is suspected.

Following diagnosis of a patient with CAH, a molecular diagnosis should be made if possible to facilitate genetic counselling and prenatal diagnosis of the condition in future pregnancies. Prenatal dexamethasone given to the pregnant mother who had given birth to a child with CAH to decrease the risk of genital virilisation in an affected female foetus should still be regarded as experimental.

## DISORDERS OF SEX DEVELOPMENT

Sexual development is a complex process which is dependent on a variety of molecular signals working in concert to specify sex-specific differentiation and organogenesis. In humans, the process of sex determination commits the bipotential gonads to become either a testis or an ovary depending on the genetic sex of the foetus. The process of sexual differentiation follows when the gonads release sex-specific signalling molecules and hormones which are responsible for shaping the phenotypic sex of the individual. Genes of several transcription factors including steroidogenic factor 1 (SF1) and Wilm's tumour 1 (WT1) are required for the formation of the indifferent genital ridges in humans. The sex determining region of the Y-chromosome gene (SRY)

expression must reach a threshold level at a critical time in the cascade of early events leading to testis differentiation, before male sex determination can occur. SOX9 encodes a transcription factor downstream of SRY and is a crucial component of the male sex-determining pathway. Loss of function mutation in SOX9 results in gonadal dysgenesis and campomelic dysplasia. Other transcription factors and signalling molecules are important in the differentiation of peritubular myoid cells, endothelial cells, Leydig cells, Sertoli cells and germ cells within the developing testes. Both the Müllerian and Wolffian ducts are present in male and female embryos. Anti-müllerian hormone (AMH) which is secreted by Sertoli cells of the testes stimulates the production of matrix metalloproteinase 2 (MMP2) which induces apoptosis in the Müllerian duct epithelial cells. The Wolffian ducts develop into the epididymis, vas deferens and seminal vesicles under the influence of testosterone produced by Leydig cells of the developing testes. A number of enzymes are responsible for testosterone biosynthesis (Fig. 21.6) and mutations in these genes will result in under masculinisation of a genetic male. Testosterone is converted to dihydrotestosterone (DHT) by 5 $\alpha$ -reductase encoded by the SRD5A2 gene. DHT signals through the androgen receptor present in the developing external genitalia to bring about the development of the phallus and scrotum which is completed by about 8 weeks gestation. Further development of the penis in males is stimulated by gonadotrophin secreted from the foetal pituitary from mid-gestation onwards. The transabdominal phase of descent of the testes is controlled by the enlargement of the caudal genitoinguinal ligament and the gubernaculum mediated by the hormone insulin-like 3 produced by the Leydig cells. The inguinoscrotal phase of descent of the testes is controlled by the neurotransmitter calcitonin gene-related peptide produced under the control of androgens.

In the absence of SRY, the Wolffian ducts regress and the Müllerian ductal system develops into the uterus, fallopian tubes and part of the vagina. Although ovarian and female genital development has been regarded as a default pathway, recent evidence suggests that there are genes important in female sexual development.

A recent suggested classification of DSD is shown in Table 21.16.

A newborn with DSD should be referred for assessment and management by a multidisciplinary team of surgeon, paediatric endocrinologist, geneticist, neonatologist, psychologist and nurse specialist in a tertiary centre. Although not easy, an attempt should be made to decide whether the newborn infant is a virilised female or an under-masculinised male. The degree of masculinisation can be assessed according to the Prader staging. Whenever a gonad is palpable, then the newborn is a genetic male. The nature of the opening

**Table 21.16:** Classification of disorder of sex development

Sex chromosome DSD	Turner syndrome 45,X and variants Klinefelter syndrome 47,XXY; 45,X/46,XY mixed gonadal dysgenesis 46,XX/46,XY ovotesticular DSD
46,XY DSD	Disorders of gonadal development: <ul style="list-style-type: none"> <li>• Complete gonadal dysgenesis</li> <li>• Partial gonadal dysgenesis</li> <li>• Ovotesticular DSD</li> </ul> Disorder of androgen synthesis or action: <ul style="list-style-type: none"> <li>• Defect in androgen action</li> <li>• Androgen biosynthetic defects</li> <li>• Luteinising hormone receptor gene mutations</li> <li>• Mutations of AMH or its receptor gene</li> </ul>
46,XX DSD	Disorder of gonadal development ovotesticular DSD: <ul style="list-style-type: none"> <li>• Ovotesticular DSD</li> <li>• Testicular DSD (SRY+, SOX9 mutation)</li> <li>• Gonadal dysgenesis</li> <li>• Androgen excess, e.g. 21-OHD</li> </ul>

Adapted from Lee PA, Houk CP, Ahmed SF, et al. *Pediatrics*. 2006;118:e488

below the clitorophallus, position of the anus should be noted and the urethral and vaginal opening identified if possible. Increased skin pigmentation in a virilised female newborn is suggestive of 21-OHD and the circulatory and hydration status should be assessed. Any dysmorphic feature should be noted.

## Diagnosis

Most of the virilised female infants will have 21-OHD while a definitive molecular diagnosis can only be reached in less than half of the children with 46,XY DSD. Initial investigations should include karyotyping with X and Y specific probe detection and measurement of plasma  $17\alpha$ -OHP, androstenedione, dehydroepiandrosterone sulphate (DHEAS), testosterone, DHT, gonadotrophins, AMH, ACTH, cortisol and serum electrolytes concentrations. An ultrasound examination of the pelvis should be performed to assess the presence or absence female internal genital organs. Further assessments of urinary steroid profile or androgen levels after human chorionic gonadotrophin stimulation may be required beyond the first 3 months of life.

## Management

Gender assignment should be based on the diagnosis, likely functional outcome to the genital organ, testosterone responsiveness, potential for fertility, surgical options and views of the parents. However, we must realise that recommendations on sex assignment are based on limited data. No management controversies exist in patients with normal male (46,XX testicular DSD) or female (complete

androgen resistance, 46,XY complete gonadal dysgenesis or LH receptor mutation) genitalia. Existing data favour male sex of rearing in all males with isolated micropenis,  $5\alpha$ -reductase or  $17\beta$ -hydroxysteroid dehydrogenase deficiencies. Testosterone enanthate 25 mg intramuscularly monthly for three doses will establish testosterone responsiveness and increase phallus size to facilitate surgical repair of chordee and urethral reconstruction. Virilised females should have recession clitoroplasty and vaginoplasty by 6 months of age. The timing of genital surgery in a 46,XY DSD patient assigned the female sex of rearing remains controversial. Some people are of the view that despite gender assignment early in life, genital surgery should be deferred and only be performed after consent from the patient 'herself'. However, with proper counselling and frank discussion after adequate information has been given to the parents, a decision to have genital surgery in a patient with 46,XY DSD in infancy can usually be reached by the multidisciplinary team and the parents. Sex hormone replacement should be initiated at the appropriate age when indicated.

Psychological support should be provided to the family. Assessment of gender identity, gender role and sexual orientation should be performed when the child is sufficiently psychologically developed. Support groups have an important role in the care of patients with disorders of sex development. Transition care is important and the patients must be provided with detailed information on their diagnosis, previous treatment and expected outcome.

## DIABETES MELLITUS

Diabetes mellitus is a common chronic childhood disorder in the Western World but is less common among Asians. As of 2009, there are 479,600 children with type 1 diabetes mellitus (T1DM) in the world, of which 23% comes from Southeast Asia and 6.3% comes from the Western Pacific region. The annual increase in incidence is 3% per year worldwide. A classification of diabetes is shown in Table 21.17 and diabetes mellitus can develop as a result of several pathogenic processes. The diagnostic criteria for diabetes mellitus are shown in Table 21.18.

### Type 1 Diabetes Mellitus

The aetiology of T1DM has remained elusive but genetic and environmental influences are thought to be important. In Caucasians, there is an association between T1DM and the HLA histocompatibility complex on chromosome 6 and the insulin gene variable number of tandem repeats (VNTRs) polymorphism on chromosome 11. These associations are less strong in Asian diabetic patients. It is likely that type 1 diabetes is a polygenic disorder. Recently, many genome wide association studies of T1DM have identified at least 24 genes

**Table 21.17:** Classification of diabetes mellitus

- Type 1 diabetes mellitus (absolute insulin deficiency):
  - autoimmune
  - idiopathic
- Type 2 diabetes mellitus (insulin resistance with relative insulin deficiency)
- Other specific types:
  - genetic defects of  $\beta$ -cell function
  - genetic defects of insulin action
  - diseases of the endocrine pancreas endocrinopathies
  - drug - or chemical-induced infections
  - uncommon immune-mediated diabetes
  - genetic syndromes associated with diabetes
- Gestational diabetes

**Table 21.18:** Diagnosis of diabetes mellitus

- Classical symptoms of polyuria, polydipsia and presence of glycosuria and ketonuria, a random sugar greater than 11 mmol/L
- In cases of asymptomatic glycosuria
  - Fasting blood sugar greater than 7 mmol/L
  - 2-hour blood sugar after oral glucose load (1.75 g/kg) greater than 11 mmol/L
- Prediabetes
  - Impaired fasting glycaemia (IFG) if fasting blood sugar between 5.6 and 6.9 mmol/L
  - Impaired glucose tolerance (IGT) if blood sugar 2 hours after oral glucose load of 7.8–11 mmol/L

and chromosomal loci each conveying a small increase in risk of developing T1DM. Ethnic groups with low incidence of disease take on a higher incidence when they migrate to another country where the incidence of diabetes is higher. This suggests that environmental factors are important. Enterovirus RNA is detected in the blood of 34% of patients with newly diagnosed T1DM. Early exposure and high dietary intake of cow's milk protein past infancy increase the risk of T1DM. Prolonged breastfeeding and vitamin D supplement decrease the risk of T1DM. Consumption of food high in preservatives and nitrosamines is associated with increased risk of T1DM. The 'hygiene hypothesis' suggests that good hygiene, vaccination and decreased childhood infections in early life lead to modulation of the immune system favouring an increased risk of development of autoimmune diseases like T1DM. There is a wide geographic difference in the incidence of childhood and adolescent diabetes mellitus. The lowest incidence is found in Asia (0.23–2.4 per 100,000 children in China) and highest in Sardinia and Finland (over 40 per 100,000 children). A significant increase in the incidence in recent years has been documented in 65% of the populations worldwide and the relative increase is more evident in populations with a low incidence of T1DM.

### Clinical Features

Diabetes mellitus is potentially a much more acute disease in the child than in the adult. The onset is marked by polyuria, excessive thirst and rapid loss of weight over a period of 2–6 weeks. Other patients may present with secondary nocturnal enuresis, vomiting, abdominal pain and abdominal distension which can mimic an acute abdomen. In females, pruritis vulvae may be a presenting complaint, and recurrent skin infections can occur. Frequently children are reported to be irritable and there is deterioration in school work. The presentation of diabetes mellitus can be preceded by an intercurrent infection.

In the untreated state, a child can present with diabetic ketoacidosis (DKA) and be admitted in a state of profound dehydration with sunken eyes, dry tongue, and scaphoid abdomen. The child can lapse into a coma. Respiration is rapid, sighing and pauseless (Kussmaul breathing). Nausea, vomiting, abdominal pain and distension may mimic an acute abdomen. The biochemical criteria for the diagnosis of DKA include hyperglycaemia (blood sugar > 11 mmol/L), metabolic acidosis (pH < 7.3 and bicarbonate < 15 mmol/L) and ketonaemia and ketonuria. DKA is the result of absolute insulin deficiency and an excess of circulating counter-regulatory hormones like glucagon, cortisol, catecholamines and GH. The incidence of DKA at presentation inversely correlates with the incidence of T1DM in that population and ranges from 15 to 70%. DKA at diagnosis is more common in children under 5 years of age. The risk of DKA in established T1DM varies between 1 and 10% per patient per year and at-risk patients include poorly controlled diabetics, adolescents, patients with eating disorder, young children and those who inappropriately manage insulin pump failure. DKA carries a mortality rate of 0.15–0.3% with cerebral oedema accounting for 60–90% of the deaths. Other causes of morbidity and mortality include pulmonary oedema, aspiration pneumonia, venous thrombosis, rhabdomyolysis and acute pancreatitis. Cerebral oedema usually occurs within 4–12 hours after starting treatment but can be present at presentation before treatment. Warning signs are headache, vomiting, slowing of heart rate, rise in blood pressure and change in the sensorium and development of neurological signs (cranial nerve palsy, incontinence). Epidemiological studies have indentified factors associated with increased risk of cerebral oedema in patients with DKA and understanding these risk factors can guide our treatment of DKA:

- Young age of new-onset diabetes with long duration of symptoms
- Severe metabolic acidosis and hypocapnoea
- An attenuated rise in serum sodium level during treatment
- Elevated serum urea
- Greater volume of fluid given in the first 4 hours

- Administration of insulin in the first hour of fluid replacement
- Treatment of acidosis with bicarbonate.

### *Diagnosis*

In the presence of classical symptoms of polyuria, polydipsia and the documentation of glycosuria, and ketonuria, a random blood sugar more than 11 mmol/L is diagnostic of T1DM. A glucose tolerance test is not usually necessary for diagnosis. DKA is present if the blood pH is less than 7.3, bicarbonate is less than 15 mmol/L in the presence of hyperglycaemia (blood sugar > 11 mmol/L) and heavy glycosuria and ketonuria. At diagnosis, the serum electrolytes, acid-base status, haemoglobin A1C, glutamic acid decarboxylase (GAD), anti-islet cell antibody (ICA) and anti-insulin antibody (IAA) should be measured. These antibodies are present in 85–90% of newly diagnosed Caucasian diabetic children and adolescents but the autoimmune form of diabetes is less common in Asians. Tests for thyroid function, thyroid antibodies and anti-gliadin, anti-endomysial and tissue transglutaminase antibodies for coeliac disease should also be performed. Children may have evidence of infection at presentation and appropriate investigations should also be undertaken. A full blood count will reveal leucocytosis with left shift and fever is present if there is intercurrent infection. There may be nonspecific elevation of amylase. The serum sodium and phosphate potassium levels may be low.

### *Management*

Diabetic ketoacidosis require prompt recognition and treatment and carries a small risk of death from cerebral oedema, aspiration and cardiac arrhythmia. In a semiconscious or unconscious patient, the gastric contents should be emptied by nasogastric suction. If a patient is severely dehydrated and suspected to be in insipient shock, resuscitation with bolus normal saline (10–20 ml/kg intravenously) should be instituted. Otherwise the fluid deficit should be replenished over 48 hours with normal saline initially and changed to half normal saline in 5–10% dextrose when the blood sugar has been brought down to 15 mmol/L or if the blood sugar fall is greater than 5 mmol/hour after intravenous insulin infusion. Insulin infusion (0.1 unit/kg per hour) should only be started 1–2 hours after starting fluid replacement and insulin infusion should be maintained until the ketoacidosis is controlled. There is no evidence that bicarbonate is necessary for the treatment of DKA. Potassium replacement (40 mmol/L of fluid) is only started when a good urine output is established. Prospective studies have not shown any clinical benefit from phosphate replacement. Blood sugar, neurological status, fluid balance should be done hourly and serum electrolytes, acid-base status should be done 2 hourly. There should be continuous electrocardiographic monitoring. The treatment can be switched to subcutaneous insulin once

the patient is fully conscious, out of ketoacidosis and able to tolerate oral feeding.

The cornerstones of diabetes management include patient education, insulin, diet, exercise and monitoring of metabolic control. The initial education can be done either as an inpatient or on an outpatient basis. At diagnosis, the patient and parents should be taught the survival skills including insulin injection, home blood glucose monitoring, recognition of hypoglycaemia, ketoacidosis and their management, diet, adjustment of insulin dosage especially during illness and for activities. Continued support should be given to the patients and their parents with a continuing educational curriculum and through the diabetes management telephone hotline.

### *Insulin Treatment*

The patients and their parents should be knowledgeable about the action of the various types of insulin that are available (Table 21.19).

Insulin can be given subcutaneously into the thighs and lower abdominal wall by fine needle syringes, pen injectors and jet injectors or by insulin infusion pump. Common insulin regimes include a mixture of short-acting and intermediate-acting insulin given before breakfast and the evening meal. In recent years, basal-bolus regime with multiple injections of insulin are preferred with a peak less long-acting insulin analogue given once or twice a day together with a short-acting insulin analogue given before the three main meals. Insulin pump treatment is increasingly used in motivated patients who desire tight control and has been used successfully even in young children with brittle diabetes. Prepubertal diabetic children will require 0.7–1 unit of insulin/kg per day. Children during puberty will require 30–50% more insulin.

### *Nutritional Management*

The diet should provide adequate nutrition and calories for optimal growth. The total energy intake should comprise 55% complex unrefined carbohydrates, 15% protein and 30% fat with less than 10% in both saturated and polyunsaturated fat. Children with diabetes should be educated on healthy eating with a diet high in vegetables, fruits and fibre. In patients on twice daily injections of short-acting and intermediate-acting insulin, the carbohydrate intake should be distributed into three main meals and three snacks in order to avoid hypoglycaemia between the main meals. Snacks may not be needed in patients on basal-bolus regime using peak less long-acting and short-acting insulin analogue before meals.

### *Monitoring of Metabolic Control and Complications*

Self-monitoring of blood sugar regularly before and 2 hours after meals and occasionally at 3 am are necessary for

**Table 21.19:** Actions of commonly used insulin preparations

<i>Insulin preparations</i>	<i>Onset</i>	<i>Peak</i>	<i>Duration</i>
Insulin lispro (Lilly)	15 min	30–70 min	2–5 hr
Insulin aspart (NovoNordisk)	15 min	60–180 min	3–5 hr
Actrapid HM (NovoNordisk)	30 min	2–4 hr	5–8 hr
Humulin S (Lilly)	30 min	2–4 hr	5–8 hr
Humulin N (Lilly)	1–2 hr	4–12 hr	12–18 hr
Protaphane HM (NovoNordisk)	1–2 hr	4–12 hr	12–18 hr
Insulin glargine (Aventis)	1–2 hr	No peak	18–24 hr
Insulin detemir (NovoNordisk)	1–2 hr	No peak	18 hr
Premixed insulin-containing different proportion of soluble neutral insulin and isophane insulin			

adjustment of insulin dosage. Patients and their parents should be educated and empowered to make day-to-day dietary and insulin adjustments to optimise metabolic control and in response to illness or physical activity. In young children under 6 years of age, tight metabolic control will result in frequent hypoglycaemia and the aim of management is to achieve reasonable symptomatic control without hypoglycaemia. Children and their parents should be seen regularly every 2–3 months by the diabetes care team of nurse educator, dietitian and paediatrician. Short-term and medium-term metabolic control can be reflected by measurements of serum fructosamine or plasma haemoglobin A1C concentrations. The paediatrician should also monitor for any psychological issues experienced by the patients or their family members and make appropriate referral for psychological counselling.

Annual screening for complications of diabetes (including retinopathy, neuropathy, nephropathy, dyslipidaemia, hypertension, thyroid dysfunction and the development of other associated disorders like coeliac disease) should be initiated at 9 years of age after 5 years of disease in prepubertal children, at 11 years after 2 years of disease and in adolescents with 2 years of disease. Screening for retinopathy is best done by annual fundus photography or by ophthalmoscopic examination after pharmacological dilatation of the pupils by an experienced ophthalmologist. Albumin excretion rate more than 200 µg/minute in two times overnight urine collections indicates early diabetic nephropathy. Impairment of fine touch, vibration threshold and tendon jerks should be looked for. The Michigan Neuropathy Screening Instrument is a useful questionnaire to screen for diabetic neuropathy in the clinic.

### Type 2 Diabetes Mellitus

Type 2 diabetes mellitus is usually regarded as a disease of people older than 40 years of age. However, with the increase in prevalence of obesity in childhood and adolescence, type 2 diabetes is increasingly reported in adolescents especially of ethnic minority or Polynesian origins. In countries where

there is annual screening for type 2 diabetes in childhood and adolescence like Japan and Taiwan, the incidence of type 2 diabetes has surpassed that of type 1 diabetes. It has been recommended that obese children and adolescents with a family history of type 2 diabetes and presence of acanthosis nigricans or other cardiovascular risk factors be screened for type 2 diabetes in every 1–2 years. The percentage of T2DM among newly diagnosed diabetic children has been reported to be increasing worldwide and T2DM seems to be less prevalent in Europe as compared to Asian and North American countries. The rising trend of obesity worldwide is an important risk factor for the development of T2DM. A recent meta-analysis reaffirmed the U-shaped association between birth weight and T2DM risk and the high prevalence of low birth weight births in Asia puts Asian populations at risk. Asians have more visceral fat and less muscle mass than Caucasians with the same body mass index. Asian diets also have a high glycaemic index and glycaemic load and in South Asians, consumption of n-6 polyunsaturated fatty acid correlated with fasting hyperinsulinaemia. Southeast Asians and South Indians have higher postprandial blood sugar and lower insulin sensitivity as compared to Caucasians.

Recent genome wide association studies have revealed more than 22 genes and chromosome loci that are associated with T2DM but all these T2DM risk variants explain at most 5–10% of the genetic basis of T2DM.

### Clinical Features

Although most of the children and adolescents with type 2 diabetes do not have any symptoms, 5–25% can present with ketoacidosis. Up to 85% of the patients have first or second degree relatives with type 2 diabetes. Acanthosis nigricans, polycystic ovary syndrome, hypertension and dyslipidaemia are common associated disorders. The differentiation of T2DM from T1DM has become increasingly difficult especially in Asians. Only 60–85% of adolescent T2DM patients are obese. Approximately 15–40% of phenotypic Caucasian T2DM patients have islet cell and insulin antibodies, GAD and tyrosine phosphatase

antibodies. Antibody positive T2DM patients are reported to have insulin deficiency while antibody negative T2DM patients are more insulin resistant. Only 40 to 60% of Asian children with T1DM are antibody positive and a slowly progressing form of autoimmune T1DM reported in Japan further complicates this issue. The rarer form of maturity onset diabetes of youth (MODY) is characterised by onset of noninsulin dependent diabetes before 25 years of age with autosomal dominant mode of inheritance involving a minimum of two but preferably three consecutive generations affected by type 2 diabetes in the family. The majority of the individuals with insulin resistance who can compensate by an adequate insulin secretion do not develop T2DM but they are still prone to the complications associated with type 2 diabetes.

### Management

Patients are encouraged to undertake regular exercise of at least 45–60 minutes per day. Obese individuals should seek dietary advice from a dietitian for a caloric and carbohydrate restricted diet to achieve a gradual weight loss of 0.5–2.0 kg per month. The importance of glycaemic control in the prevention of diabetes complications has been shown in both types 1 and 2 diabetes. Patients who are not adequately controlled ( $HbA_{1C} > 7\%$ ) on lifestyle changes and diet should be treated with oral antidiabetic agents (biguanides, sulphonylureas, thiazolidinediones, glucosidase inhibitors). Insulin therapy should be initiated if metabolic control cannot be achieved by diet and oral antidiabetic drugs. Hypertension and dyslipidaemic should be aggressively managed. Although the case for screening for undiagnosed T2DM or prediabetes is getting stronger, it remains to be proven that early detection and treatment will reduce morbidity and mortality.

## HYPOGLYCAEMIA

Blood glucose is the main metabolic fuel of the brain and it is maintained in a relatively narrow normal range of 4.4–6.7 mmol/L by a number of hormones including insulin, glucagon, cortisol, GH and catecholamines. Hypoglycaemia in neonates is defined as a blood sugar below 2.6 mmol/L and would require further investigation but autonomic and neuroglycopenic symptoms will appear when the blood sugar falls below 3.5 mmol/L in older children. The common causes of hypoglycaemia in infants and children are shown in Table 21.20.

### Clinical Features

Mild to moderate hypoglycaemia can result in autonomic nervous system activation including hunger, trembling of extremities, pallor, sweating and palpitations and manifestation

**Table 21.20:** Causes of hypoglycaemia in infants and children

- Intrauterine growth retardation and prematurity
- Perinatal asphyxia
- Infant of diabetic mother
- Intrauterine infection and sepsis
- Rhesus incompatibility
- Inborn errors of metabolism
  - Amino acids and organic
  - Disorders of carbohydrate metabolism, e.g. glucoma storage disease, fructose intolerance, lactosaemia
  - Fatty acid oxidation defects
  - Urea cycle defects
- Endocrine causes
  - Hypopituitarism
  - Growth hormone or adrenal insufficiency
  - Persistent hyperinsulinaemic hypoglycaemia of infancy
  - Beckwith-Wiedemann syndrome
  - Insulinoma
- Ketotic hypoglycaemia
- Drugs including alcohol, aspirin,  $\beta$ -blockers
- Sepsis especially due to gram-negative organisms

of neuroglycopenic symptoms. Neuroglycopenia leads to confusion, irritability and abnormal behaviour, jitteriness, headaches, paraesthesia of the extremities and dizziness. Severe hypoglycaemia can result in coma and convulsion. Prolonged and severe hypoglycaemia with coma and convulsion can lead to permanent neurological sequelae.

### Investigations

Although hypoglycaemia require prompt treatment once identified (usually by a low glucometer sugar reading at the bedside), it is important to document the true blood sugar and obtaining critical samples (blood for GH, cortisol, insulin, free fatty acids, blood ketones and  $\beta$ -hydroxybutyrate, lactate, ammonia and urine for ketones and toxicology). Nonketotic hypoglycaemia is due to hyperinsulinism or fatty acids oxidation defects. Hyperinsulinaemic hypoglycaemia is diagnosed when in the presence hypoglycaemia, insulin level is inappropriately elevated ( $> 3$  mU/ml), plasma free fatty acids ( $< 1.5$  mmol/L) and  $\beta$ -hydroxybutyrate ( $< 2.0$  mmol/L) are low, a high glucose infusion rate is required to maintain euglycaemia ( $> 10$ – $12$  mg/kg per min) and the presence of an exaggerated glucose response to glucagon. Hyperinsulinaemic hypoglycaemia with hyperammonaemia is suggestive of a gain of function mutation of the glutamate dehydrogenase gene. Perinatal stress hyperinsulinism is reported in 10% of SGA neonates. Fatty acid oxidation defect can be diagnosed by measurement of plasma acylcarnitine profile and urine organic acids. Ketotic hypoglycaemia commonly occurs in young children following prolonged



fasting, decreased intake or repeated vomiting. It is always important to look for sepsis (especially with gram-negative organisms) as a treatable cause of hypoglycaemia. Further assessment for hypopituitarism should be carried out where indicated.

### Management

Hypoglycaemia should be treated promptly after obtaining the critical samples by intravenous infusion of 2–4 ml/kg of 10% dextrose followed by an adequate glucose infusion to maintain euglycaemia. Treatment should also be aimed at the underlying cause of the hypoglycaemia. Oral diazoxide

(10–15 mg/kg per day) and octreotide given by subcutaneous injection have been successfully used to manage the persistent hyperinsulinaemic hypoglycaemia of infancy and near total pancreatectomy is the only option in drug resistant cases. In diazoxide resistant cases, re-secretion of the focal lesion (diagnosed by <sup>18</sup>F-fluorodopa PET scan) is curative. In diffuse hyperplasia, near total pancreatectomy will need to be performed. Patients with autosomal recessive KATP channel mutations and certain glucokinase gene mutation (Y214C) are unresponsive to diazoxide <sup>18</sup>F-fluorodopa PET scan is 96% accurate in diagnosing focal or diffuse disease. Patients with ketotic hypoglycaemia should avoid prolonged fasting.

# Paediatric Orthopaedics

# 22

## INTRODUCTION

Children may present with a variety of symptoms related to the musculoskeletal system (Box 22.1). It is important to be aware of symptoms that are likely to be innocuous and those that may herald serious underlying disease that requires early treatment. Several conditions need no active treatment; reassurance to allay parental anxiety is all that is required. Another group of conditions may need to be monitored as spontaneous improvement occurs with growth in most cases but in a few instances deterioration may occur, warranting some intervention. The third group of conditions always needs elective, early or urgent immediate treatment. In other words, the children may be managed in one of three ways;

1. Reassurance (no active intervention),
2. Observation (often no treatment is needed but treat later in selected situations),
3. Active intervention (elective intervention, early intervention or urgent intervention).

It is vitally important that this third group is identified and referred to the Paediatric Orthopaedic Surgeon without any delay. In order to try to work out which of these groups the symptom of a particular child would fall into, there are some basic questions that need to be answered. Throughout this chapter the relevant questions to be asked regarding each symptom would be indicated and an attempt will be made to clarify which of these three approaches is appropriate for the particular condition.

**Box 22.1:** Common symptoms with which children may be brought to an orthopaedic surgeon

- Deformities
- Gait abnormalities
- Musculoskeletal pain
- Paralysis and pseudoparalysis
- Joint stiffness and limitation of movement
- Other e.g. Soft tissue swelling/bony swelling/frequent fractures/limb deficiencies

## DEFORMITIES

By far the most common reason for a child being referred for an orthopaedic opinion is the presence of a deformity. The questions that need to be asked regarding a child with a deformity of the upper or lower limbs are listed in Table 22.1.

Some of the common deformities seen in Paediatric Orthopaedic clinics are shown in Table 22.2. It is clear that a quarter of these conditions need no active treatment. However, it needs to be emphasised that these benign conditions form a much larger proportion of the cases seen in the clinic.

## GAIT ABNORMALITIES

The common gait abnormalities seen in children are shown in Box 22.2. The questions that need to be asked while evaluating a child with a gait abnormality are listed in Table 22.3. With the exception of a painful limp, all other gait abnormalities do not require urgent intervention and hence can be evaluated without undue haste.

## Delayed Walking

Delayed walking is quite alarming for parents and a thorough examination of these children is warranted to

**Table 22.1:** Questions to be asked regarding a limb deformity in a child

Question	Relevance
Is the deformity unilateral or bilateral?	Unilateral deformity is more likely to be pathological.
Was the deformity present from birth?	Most deformities that are present from birth either resolve or remain static; only a few progress.
Is the deformity remaining static or is it resolving or progressing?	A deformity that is progressing may indicate that the growth mechanism is affected and would probably need early treatment. A deformity that is resolving just needs to be periodically observed.

**Table 22.2:** Common deformities seen in the paediatric orthopaedic clinic

Region	Aetiology	Condition	Management
Foot	Congenital	Clubfoot	Treat early
		Metatarsus adductus	Observe/Treat electively
		Calcaneovalgus	Observe
	Developmental	Vertical talus	Treat early
		Mobile flatfoot	Observe
		Rigid flatfoot	Treat electively
	Paralytic	Equinus	Treat electively
		Equinovarus or equinovalgus	Treat electively
		Calcaneus or calcaneovalgus	Treat early
Cavus		Treat electively	
Leg	Congenital	Anterolateral bowing	Treat early
		Posteromedial bowing	Observe
		Internal tibial torsion	Observe
Knee	Congenital	Hyperextension	Treat early
		Flexion	Treat electively
	Developmental	Physiological genu varum or valgum	Observe
Hip	Congenital	Unilateral genu valgum or varum	Treat electively
		Acetabular dysplasia with neonatal hip instability	Treat early
		Femoral anteversion	Observe
Spine	Developmental	Coxa vara	Treat electively
	Congenital	Scoliosis	Treat electively
		Developmental	Infantile scoliosis
	Paralytic	Adolescent scoliosis	Treat early
		Scoliosis	Treat early

**Table 22.3:** Questions to be asked while evaluating a child with a gait abnormality

Question	Relevance
Does the child have pain on walking?	If there is pain on walking, urgent investigations are needed to establish the definitive diagnosis as some conditions that cause a painful limp require immediate treatment.
Is the gait abnormality unilateral or bilateral?	Unilateral gait abnormality is more likely to be pathological.
Has the gait abnormality been present from when the child started to walk?	If present from when the child started to walk it is likely to be due to a congenital abnormality.
Does the child run, play and do normal activities with peers?	If the child does play normally it indicates that there is negligible pain and that the underlying problem is probably not serious.
Is there an improvement in the gait pattern with growth?	If the gait improves as the child grows the underlying problem is likely to be "physiological".
Is there a deterioration of the gait pattern with growth?	If gait deteriorates as the child grows there is some underlying pathology.

**Box 22.2:** Common gait abnormalities seen in children

- Delayed walking
- Toe-walking
- In-toeing gait
- Out-toeing gait
- Short-limbed gait
- Waddling gait
- Painful (antalgic gait)
- Paralytic gait patterns: High stepping gait/hand-to-knee gait/crouch gait/scissor gait, etc.

determine if there is global developmental delay. The most common cause of delayed walking that is associated with global developmental delay is cerebral palsy. Some children with some forms of severe ligament laxity syndromes tend to walk late without demonstrating any other developmental delay. It had been assumed in the past that developmental dysplasia of the hip with an established dislocation delays walking. However, there is little evidence to support this assumption.

## Toe-walking

Children who walk on their toes again need to be evaluated carefully. Among causes for toe-walking are cerebral palsy, some forms of myopathies and muscular dystrophies and a very benign condition known as habitual toe-walking. Habitual toe walking is a diagnosis of exclusion and it is important that the more serious causes of toe-walking are definitely excluded before this diagnosis is made. Initially these children can bring their heels down to the ground while standing but go onto their toes when they start walking. In due course the Achilles tendon may get contracted and then they would also stand on tip toe. At this stage lengthening of the Achilles tendon is indicated.

## In-toeing Gait

This is a very common complaint and parents are often very concerned about this gait abnormality. The child typically sits in the “W” position (Fig. 22.1) and examination of the range of passive hip motion would demonstrate excessive internal rotation of the hip with a reduction in the range of external rotation. This is characteristic of excessive femoral anteversion. The anteversion tends to reduce spontaneously as the child grows. There is no functional disability though these children tend to be a bit clumsy and some parents feel that they tend to trip more frequently. The parents need to be reassured that gradual resolution of the torsional deformity will occur. Bracing and shoe modifications that have been tried in the past have been quite clearly shown to be totally ineffective and should not be used. Surgical intervention is



**Fig. 22.1:** This posture while sitting is characteristically seen in children with excessive femoral anteversion. It is referred to as the “W” pattern because the legs and the thighs of both the limbs together are aligned in the form of a “W”

not justified in these children except in the very rare instance where the deformity persists till the age of ten years and is still severe at this age.

## Out-toeing Gait

This is less frequently seen and may be due to retroversion of the femur or external tibial torsion. Again, there is no functional disability in these children and no active treatment is required.

## Short-limbed Gait

A short-limbed gait indicates that there is a structural abnormality of one limb. While more commonly the shorter limb is at fault due to reduced growth, occasionally the longer limb may be abnormal. Lengthening of one limb is often seen in association with vascular malformations such as hemangioma, lymphangioma, and arteriovenous fistula. The decision to correct the limb-length inequality is governed by the magnitude of the discrepancy that is likely to be present at skeletal maturity. If the difference at skeletal maturity is likely to exceed 2 to 3 centimeters, intervention may be considered.

## Waddling Gait

A waddling gait or a Trendelenburg gait is characteristically seen when the hip abductor power is weak. This may be seen in the relatively uncommon situation where there is actual paralysis of the hip abductors. Far more commonly, this gait pattern is seen when the hip abductor mechanism is rendered ineffective either due to dislocation of the hip or due to a reduction of the angle between the neck and shaft of the femur as in coxa vara deformity. This gait pattern signals serious hip pathology and so children with a waddling gait must be evaluated carefully and must have radiographs of the pelvis to exclude these conditions that require surgical intervention.

## Antalgic Gait

An antalgic gait or painful gait signifies that bearing weight on the affected limb causes pain. Children who demonstrate this abnormality of gait should undergo a meticulous examination to identify the source of pain and in the vast majority of instances the site of pain can be located by clinical examination alone. Appropriate imaging may then be done to confirm the nature of underlying pathology. Treatment would depend on the nature of the pathological process that is producing pain. Of all conditions that can manifest with a painful limp the one that requires immediate surgical intervention is osteoarticular infection. The urgency for establishing a diagnosis and the need for immediate intervention cannot be overemphasised.

**Table 22.4:** Causes of musculoskeletal pain in children

Region	Condition	Imaging modality to supplement clinical examination	Management approach
Foot	Sever's disease	X-ray	Observe
	Kohler's disease	X-ray	Observe
	Tarsal coalition	X-ray/CT scan	Treat electively
Calf	Growing pains	No imaging	Reassure
Tibia	Osteoid osteoma	X-ray/CT scan	Treat electively
	Acute osteomyelitis	No imaging/Ultrasound scan	Treat urgently
	Osteosarcoma	X-ray/CT/MRI	Treat urgently
	Ewings tumour	X-ray/CT/MRI	Treat urgently
Knee	Osgood-Schlatter	X-ray	Observe
	Septic arthritis	No imaging	Treat urgently
	Tubercular arthritis	X-ray	Treat early
	Referred Pain from the hip		
Hip	Transient synovitis	Ultrasound scan	Treat early
	Perthes' disease	X-ray	Treat early
	Slipped capital femoral epiphysis	X-ray	Treat urgently
	Septic arthritis	No imaging	Treat urgently
	Tubercular arthritis	X-ray	Treat early
Back	Disc prolapse	MRI	Treat early
	Pyogenic discitis	X-ray/CT/MRI	Treat early
Generalised bone pain	Osteogenesis imperfecta	X-ray	Treat early
	Adolescent osteoporosis	X-ray/CT/Dexa	Treat early

It will also be evident that several of the conditions listed in Table 22.4 require urgent or early treatment. This is distinctly different from that seen in the conditions listed in Table 22.2.

The questions that need to be asked while evaluating a child with musculoskeletal pain are shown in Table 22.5.

**Table 22.5:** Questions to be asked while evaluating a child with musculoskeletal pain

Question	Relevance
Can the pain be localised consistently?	Likely to be caused by localised pathology
Is the pain brought on by movement of a joint?	Likely to be due to pathology in the joint
Is the pain present at rest and on bearing weight on the limb?	Likely to be due to disease of bone
Is the child able to run and play normally but has pain at rest after physical activity?	The cause is likely to be innocuous.
Is the child unable to bear weight on the limb?	If the child cannot bear any weight on the limb, it is likely that there is serious underlying pathology.

## Paralytic Gait Patterns

Depending on the pattern of paralysis, typical gait aberrations may occur. Paralysis of the ankle dorsiflexors will produce a high-stepping gait. A hand-on-thigh gait is seen when there is paralysis of the quadriceps muscle. Characteristic abnormal gait patterns such as scissor gait, crouch gait, stiff-knee gait and toe-toe gait are seen in cerebral palsy depending on which muscles are most spastic.

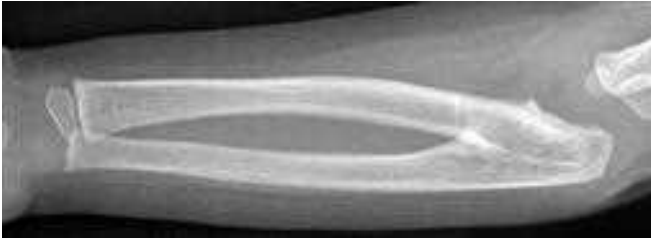
## MUSCULOSKELETAL PAIN

When a child complains of pain in the limbs or back, it is imperative that a careful examination is performed and this

should be followed by appropriate imaging. It will become clear from the list of painful conditions seen in children (Table 22.4) that most of these conditions can be confirmed by a combination of clinical examination and imaging.

## PARALYSIS AND PSEUDOPARALYSIS

When an infant stops moving a limb, a distinction needs to be made between true paralysis and pseudoparalysis. The later phenomenon is on account of pain and this is typically seen when there is osteoarticular infection. Since the infant cannot indicate the site of pain it is important to do a meticulous examination to try to ascertain the site of pain. In the older child with true paralysis, it is necessary to differentiate



**Fig. 22.2:** Radiograph of a child's elbow showing congenital synostosis of the radius and ulna

between flaccid, lower motor-neuron paralysis and spastic, upper motor-neuron paralysis.

## JOINT STIFFNESS

Stiffness of a joint or limitation of joint movement can occur on account of abnormalities within the joint itself (intra-articular pathology) or due to contracture or shortening of soft tissue structures outside the joint (extra-articular). Intra-articular stiffness can be caused by adhesions between the articular surfaces or due to actual bony continuity between the bones that form the joint. Bony continuity can be of congenital origin due to failure of segmentation and formation of a joint space resulting in a synostosis. The common sites of synostosis include the proximal radioulnar joint, the carpus and the tarsus (Fig. 22.2). If the articular cartilage is dissolved in septic arthritis, the raw bony surfaces may fuse together. This is referred to as bony ankylosis. When either a congenital synostosis or an acquired bony ankylosis is present no movement will be present at all in the affected joint.

## CONGENITAL ANOMALIES

### Congenital Clubfoot

*Treatment Approach: Treat Early*

Congenital clubfoot (congenital talipes equinovarus) is probably the most common congenital anomaly of the musculoskeletal system that requires treatment (Fig. 22.3). Clubfoot may occur as an isolated anomaly (idiopathic clubfoot) or may occur in association with spina bifida or



**Fig. 22.3:** Appearance of congenital clubfoot—equinus and varus deformities of the hindfoot and forefoot adduction are clearly seen

with multiple congenital contractures (MCC—formerly called arthrogryposis multiplex congenita). Idiopathic clubfoot is far more common than the neurogenic form that occurs with spina bifida or MCC. Idiopathic clubfoot may either be postural or rigid. The postural variety is due to intrauterine molding; the foot is structurally normal and responds well to non-operative management. On the other hand, the rigid variety is characterised by contractures of muscles and joint capsules and the bones of the foot are structurally abnormal. Despite this, a proportion of these rigid feet do respond to non-operative treatment.

The deformity is a complex one with individual deformities at the ankle, subtalar and the midtarsal joints (the calcaneocuboid joint and the talonavicular joints function together in unison and are referred to as the midtarsal joint). These individual deformities are caused primarily by contractures of muscles that act on these joints; and secondary contractures of the joint capsules make the deformities more rigid (Table 22.6).

Management of clubfoot should first begin with a careful examination to determine whether the deformity is associated with a swelling in the lumbosacral region (spina bifida) or with symmetrical deformities of the knees, elbows and wrists (MCC). Once these conditions have been excluded, an attempt is made to gently correct the deformity (Fig. 22.4).

**Table 22 6:** Deformities of clubfoot and the underlying contractures that contribute to these deformities

Region of the foot	Joint	Deformity	Primary muscle contracture	Secondary contracture
Hindfoot	Ankle Subtalar joint	Hindfoot equinus	Gastrocsoleus	Posterior capsule of ankle joint
		Hindfoot varus (a combination of adduction and inversion)	Tibialis posterior	Medial capsule of the subtalar joint
Mid-foot	Mid-tarsal joint	Forefoot adduction	Abductor hallucis	Medial capsule of the talonavicular and calcaneo-cuboid joints
		Forefoot inversion	Tibialis posterior	
		Forefoot equinus	Short plantar muscles	Plantar aponeurosis



**Fig. 22.4:** Gentle passive correction of clubfoot in a neonate should be done without causing any pain

If the deformities can be completely corrected by passive stretching, the clubfoot is likely to be a postural clubfoot.

### Serial Manipulation

To begin with, all idiopathic clubfeet should be given a trial of serial manipulation. Treatment should be started as soon as possible after birth. The feet are manipulated without sedation or anaesthesia to ensure that excessive force is not used. At the first sitting, partial correction of the deformity is achieved and with each subsequent sitting more and more correction is achieved. After each manipulation a plaster of Paris cast that extends from the tips of the toes to the groin is applied with the foot in the position of correction that has been achieved. The forefoot deformities and the hindfoot varus are corrected first. Only after these deformities are well corrected should any attempt be made to correct the hindfoot equinus. Full correction of the deformity may be achieved after four or five manipulations. If the hindfoot equinus cannot be corrected by manipulation, percutaneous tenotomy of the Achilles tendon would be needed. A small proportion of feet will not respond to this treatment and these feet would need surgical correction. The success with this method of manipulative correction steadily decreases with increasing age and often this method will not be effective in infants over six to nine months of age.

### Soft Tissue Release

Soft tissue release is indicated in children who have not responded well to serial manipulation and in children who are too old for serial manipulation. Soft tissue surgery entails lengthening of the tendons of the contracted muscles and division of the contracted capsules. Since structures on the back and medial aspect of the foot need to be released, the operation is referred to as a posteromedial soft tissue release.

Ideally, soft tissue release should be performed by 9 months of age so that by the time the postoperative plaster immobilisation for 3 months is over the child will be able to start walking.

Satisfactory correction of the deformity should result in a supple, normal looking foot that functions well throughout life.

### Bony Surgery

Children with clubfoot who present after four or five years of age would need additional surgery on the bones of the foot in order to correct the deformity as the tarsal bones would have been deformed by weight-bearing. The common operations include osteotomies of the calcaneum to correct the hindfoot varus and osteotomies of the cuboid and cuneiform bones aimed at shortening the lateral border of the foot or lengthening the medial border of the foot.

Occasionally one may encounter an older child or an adolescent with untreated clubfoot. It is possible to correct the deformity even at this age by either resecting wedges of bone from the dorsolateral aspect of the foot or by distracting the contracted soft tissues with the help of an external fixator mounted on the limb through wires that pass through the leg and foot. It needs to be emphasised that any form of surgery to correct clubfoot in the older child will result in a stiff foot even if the deformity can be completely corrected.

### Clubfoot in Spina Bifida

Clubfoot in spina bifida is more difficult to treat. Manipulation and plaster casts are better avoided on account of the risk of producing pressure sores on the anesthetic feet. There may also be muscle imbalance due to paralysis of some muscles acting on the foot and ankle and this must be addressed or else the deformity will recur.

### Clubfoot in MCC

Clubfoot in MCC is far more rigid than idiopathic clubfoot and hence nonoperative methods are not likely to succeed. There is also a very high chance of relapse of the deformity following surgical correction. In view of this, surgery should be more radical with excision of segments of the contracted tendons rather than mere lengthening as done in idiopathic clubfoot.

### Metatarsus Adductus

#### *Treatment Approach: Observe/Treat Electively*

Metatarsus adductus is a congenital anomaly where the forefoot is adducted. It resembles the forefoot adduction component of clubfoot; but the deformity is at the tarso-metatarsal joints rather than at the midtarsal joint as in



**Figs 22.5A and B:** Clinical appearance of the foot of a child with metatarsus adductus

clubfoot (Figs 22.5A and B). Metatarsus adductus may be associated with other deformities such as infantile scoliosis, torticollis and plagiocephaly all of which may be part of the molded baby syndrome.

Milder degrees of metatarsus adductus tend to resolve and hence one can wait for a few years to see if resolution of the deformity occurs. The more severe deformity may need release of the abductor hallucis muscle or osteotomies of the bases of the metatarsal bones.

### Calcaneovalgus

#### *Treatment Approach: Observe*

Congenital calcaneovalgus deformity may occur in isolation or with congenital posteromedial bowing of the tibia. Calcaneovalgus deformity is a postural deformity that develops on account of intrauterine molding. At birth, the foot is dorsiflexed and everted; the dorsum of the foot may be in contact with the shin (Fig. 22.6). Despite this apparently severe deformity, rapid spontaneous resolution occurs. Spontaneous resolution can be facilitated by gentle stretching of the foot into plantar flexion and eversion by the mother several times a day. Very occasionally, a few casts holding the foot in plantar flexion and inversion may be needed.

If there is an associated posteromedial bowing of the tibia, the parents need to be reassured that the tibial deformity again is likely to resolve spontaneously. However, these children do need to be followed up as residual tibial deformity and shortening of the limb that may occur in some children may need to be addressed later in childhood.



**Fig. 22.6:** Calcaneovalgus deformity of the foot in a newborn infant

### Congenital Vertical Talus

#### *Treatment Approach: Treat Early*

Congenital vertical talus is a complex, rigid deformity of the foot that is often associated with spina bifida, chromosomal anomalies (Trisomy 13 and 18) and MCC. The ankle is plantar flexed and the forefoot is dorsiflexed; consequently there is a total reversal of the normal longitudinal arch of the foot. This is referred to as a rocker-bottom deformity (Fig. 22.7). The talus is severely plantar flexed (hence the name of the condition) and the talonavicular joint is dislocated.





**Fig. 22.7:** In congenital vertical talus the medial longitudinal arch of the foot is reversed and this is described as a rocker-bottom deformity

There is also a valgus deformity of the foot (Table 22.7). Nonoperative treatment in the form of serial manipulations should be started early. However, the deformities usually will not correct completely by nonoperative treatment and surgery is needed to release the contracted structures and to restore normal tarsal relationships. The extent of surgery may be minimized by serial manipulation and casting.

### Anterolateral Bowing of the Tibia

#### *Treatment Approach: Treat Early*

Bowing of the tibia may be present at birth. The location and the direction of the convexity of the bowing should be identified. When the child is born with anterolateral bow of the tibia, a careful examination must be made to look for pigmented spots (café-au-lait spots) on the trunk or limbs. These spots suggest that the child has neurofibromatosis. If these spots are not present on the baby, examination of the parents may show features of neurofibromatosis in either of

them. The radiograph of the limb may show narrowing of the tibia at the junction of the middle and lower third of the leg with obliteration of the medullary cavity. If these changes are noted, the limb needs to be protected in a splint to prevent the tibia from fracturing. If the tibia does fracture, union will not occur by simple immobilisation (fractures in infants and young children normally heal quite quickly by immobilisation in a cast) and will go on to develop a pseudarthrosis that is exceedingly difficult to treat.

In contrast to anterolateral bowing of the tibia, posteromedial bowing is far more benign and spontaneous resolution of the bowing will occur. It is important to clearly identify the direction of the bowing as the natural history and the prognosis are so different in the two types of bowing.

### Developmental Dysplasia of the Hip

#### *Treatment Approach: Treat Early*

The term “developmental dysplasia of the hip” has replaced the older term “congenital dislocation of the hip” since true dislocation of the hip is not present at birth though the factors that predispose to dislocation are present at birth. Developmental dysplasia of the hip (DDH) covers a spectrum of hip abnormality that includes neonatal hip instability, subluxation and dislocation of the hip and acetabular dysplasia without hip instability. The cause of DDH is multifactorial and among the causes are two clearly defined heritable predisposing factors, namely, ligament laxity and acetabular dysplasia. DDH occurs six times more commonly in girls than in boys; it occurs far more frequently in breech deliveries and in those with a definite family history of DDH.

Unlike most other musculoskeletal congenital anomalies, DDH is not apparent unless one specifically examines the newborn for signs of neonatal hip instability. If the diagnosis of neonatal hip instability is not made, the hip may dislocate in early infancy and this too may remain undetected till the child begins to walk with a limp. Treatment of neonatal instability is relatively simple both for the baby and the treating surgeon, while treatment becomes increasingly difficult as the child grows older. Furthermore, the results of treatment deteriorate as the age at treatment increases; the best chance of obtaining

**Table 22.7:** Deformities of congenital vertical talus and the underlying contractures that contribute to these deformities

Region of the foot	Joint	Deformity	Primary muscle contracture	Secondary contracture
Hindfoot	Ankle	Hindfoot equinus	Gastrocsoleus	Posterior capsule of ankle joint
	Subtalar joint	Hindfoot valgus (a combination of abduction and eversion)	Peroneus longus and brevis	Lateral capsule of the subtalar joint
Mid-foot	Mid-tarsal joint	Forefoot abduction	Peroneus brevis	Lateral capsule of the calcaneocuboid joint
		Forefoot dorsiflexion	Tibialis anterior, extensor hallucis, extensor digitorum, peroneus tertius	Dorsal capsule of the talonavicular joint



**Fig. 22.8:** The method of holding the infant's thighs while performing the Barlow and Ortolani tests for detecting neonatal hip instability

an excellent outcome is if treatment is instituted in the neonatal period itself. Hence, it is imperative that every newborn child is screened for hip instability.

### Screening for DDH

The two main methods of screening are clinical and ultrasonographic. For obvious logistic and economic reasons, it would just not be feasible to screen every newborn in a developing country by ultrasound and hence clinical screening will remain the mainstay of diagnosis of DDH for a long time to come. It is important that every clinician who attends to the newborn is adept at performing the screening tests for neonatal hip instability. This is particularly vital in situations where a paediatric orthopaedic surgeon may not be available.

The two clinical tests for detecting hip instability in the newborn are the Barlow's test and the Ortolani's test. Both these tests should be performed with the baby lying on its back. The thigh is grasped with the thumb of the examiner on the medial side of the thigh and the index and middle fingers over the greater trochanter (Fig. 22.8). The hip is flexed to 90° and the Barlow's test is first performed.

The hip is adducted and at the same time, pressure is applied by the thumb on the medial aspect of the thigh to attempt to push the femoral head posteriorly and laterally. If the hip is unstable the femoral head can be clearly felt moving out of the acetabulum. This provocative test, if positive, signifies that the hip is "dislocatable". Then the Ortolani's test is performed. Pressure is applied on the greater trochanter by the index and middle finger attempting to push the femoral head medially and anteriorly while the

hip is abducted. The femoral head can be felt reducing into the acetabulum with palpable click. This is the Ortolani's test which when positive implies that the hip is "reducible".

### Treatment of Neonatal Hip Instability

If either of these tests is positive the hips are splinted in flexion and abduction in a Pavlik harness (Fig. 22.9). The harness is maintained for six weeks, by which time the hip ought to have become stable. If the hip has not stabilised by this time, closed reduction must be performed under anaesthesia as outlined below. In infants over six months of age the Pavlik harness is not likely to be effective.

### Treatment of DDH in Infants under 6 Months of Age

If the hip does not become stable in spite of splinting in a Pavlik harness, the child needs to be anaesthetised and then the hip is examined, to see if it will reduce. In the vast majority of instances the hip will reduce. Once it is noted that the hip does reduce, a careful assessment is made to determine the position in which the hip remains reduced. If the hip remains reduced in around 45° of abduction and neutral rotation of the hip, a spica cast extending from well above the costal margin to the tips of the toes is applied with the hips flexed to 90° and abducted to 45° (Fig. 22.10). The spica is changed under anaesthesia at monthly intervals and at each change the stability of the reduction is assessed. Usually, the hip will become quite stable within 3–4 months, at which time the spica cast can be abandoned. If the hip has to be abducted over 60° or if the hip has to be internally rotated a great deal in order to keep the hip reduced, surgical open



**Fig. 22.9:** The hips of a neonate with neonatal hip instability are splinted in flexion and abduction in a Pavlik's harness



**Fig. 22.10:** Spica cast applied after closed reduction in an infant with developmental dysplasia of the hip

reduction if the hip should be undertaken as immobilisation in these positions of excessive abduction and internal rotation can jeopardize the blood supply to the femoral head. Open reduction is also indicated in children under six months of age if the hip cannot be reduced by closed reduction under anaesthesia.

#### *Treatment of DDH between the Age of 6 and 18 Months*

Once the hip dislocates and remains dislocated, soft tissue contractures will develop and they would prevent the hip from being reduced. This is seen in a proportion of children over six months of age. These children would have to undergo an open reduction of the hip. During the operation, the soft tissue impediments to reduction need to be identified and removed; these include contracture of the inferomedial capsule, iliopsoas tendon, the ligamentum teres and fibro-fatty tissue in the floor of the acetabulum. The hip is immobilised in a spica cast for three months following the open reduction. If on the other hand, the hip does reduce when examined under anaesthesia the treatment can be as for children under six months of age.

#### *Treatment of DDH in Children between 18 Months and 3 Years*

Adaptive changes will develop in the femur and the acetabulum in a child who has been walking with a dislocated hip, and these would need to be addressed in order to obtain a stable reduction. The femur may be excessively anteverted and the neck may develop some degree of valgus. The acetabulum may become even more dysplastic and sloping. In addition, the muscles that cross the hip would become excessively contracted. Consequently the femur may need to be shortened in order to reduce the hip. Varus de-rotation osteotomy may be needed to ensure that the femoral head is directed towards the center of the acetabular floor. The normal slope of the acetabulum may need to be restored in



**Figs 22.11A and B:** Acetabular dysplasia in a child (A) has been corrected by an osteotomy of the pelvic bone (B)

order to prevent the hip from subluxating again after the reduction has been achieved (Fig. 22.11). All or some of these bony operations may be needed in addition to an open reduction in these older children.

It is important to follow up all children who have been treated in early childhood for DDH till they are skeletally mature as late subluxation and acetabular dysplasia may occur in a few children. These problems can be promptly addressed if children are reviewed on a regular basis through their childhood.

### **Congenital Scoliosis**

#### *Treatment Approach: Treat Electively*

Congenital scoliosis occurs on account of anomalous development of the vertebral column; this may be failure of development of a part of the vertebra or failure of segmentation. Failure of formation of part of the vertebra results in a hemivertebra, while failure of segmentation can

result in block vertebrae or unsegmented unilateral bars. The embryonal mesodermal tissue of the sclerotomes from which the vertebrae develop, is very close to the mesoderm that goes to form the urogenital tract. Consequently, very often, children with congenital scoliosis have associated anomalies of the renal tract. This must be borne in mind and children with congenital scoliosis should be screened for renal and other visceral anomalies.

Due to asymmetric growth of the spine, the deformity may progress relentlessly and neurological deficit may develop in the limbs on account of stretching of the spinal cord. Surgical intervention may be needed in early childhood to prevent rapid progression of the scoliosis. This may involve excision of the hemivertebrae and spinal fusion.

## DEVELOPMENTAL PROBLEMS

### FLATFOOT

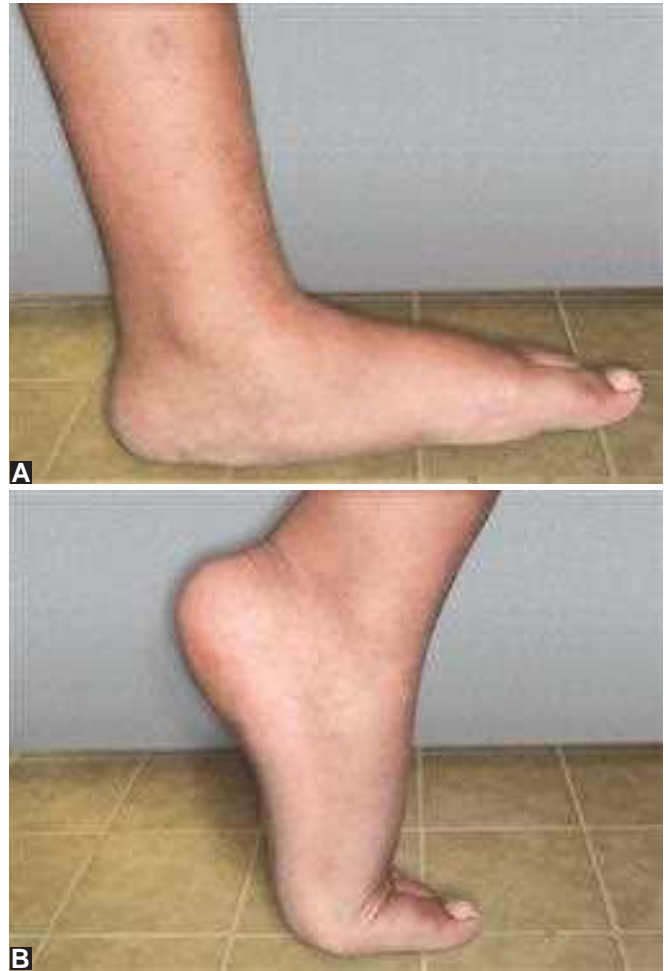
Flatfoot is a condition where the medial longitudinal arch of the foot is not well formed or has collapsed. At the outset it is imperative that a distinction is made between a mobile, flexible flatfoot and a rigid flatfoot. This distinction can be made very easily by simply asking the child to stand normally and then to stand on tip-toe. While the child is standing normally it would be seen that the medial longitudinal arch is collapsed and the instep of the foot is resting on the ground. However, as the child stands on tip-toe the arch is completely restored (Figs 22.12A and B). Such a flatfoot is a mobile or flexible flatfoot. In children with rigid flatfeet no restoration of the arch will be noted on standing on the toes.

It is important to be aware that the foot appears flat in the vast majority of infants on account of fat in the instep region. In addition to this, the joints of young children are more lax and consequently the ligaments that support the arch, are not taut and the arch flattens when the child bears weight on the foot. By around five or six years of age the ligaments of most children tighten up and the medial longitudinal arch forms. There is evidence to suggest that the arch develops better in children who do not wear footwear. Among children who use footwear from early childhood, those that wear closed-toe shoes appear to have poorer development of the arch than children who wear sandals or slippers.

#### Flexible Flatfoot

##### *Treatment Approach: Reassurance*

Flexible flatfoot is far more common in children who have hypermobile joints and in children who are obese. Less than 1% of children with flexible flatfeet have any symptoms related to the foot. Yet parents are often very concerned about flatfeet in their children. There is also an unsubstantiated



**Figs 22.12A and B:** The arch of the foot of a child with flexible flatfoot (A) is restored on standing on tip-toe (B)

notion that flatfeet function badly and limit the activity of the child. It is important that parents are counselled and informed that there is no need to treat asymptomatic flatfeet. The tendency to prescribe shoe modifications for young children with asymptomatic flexible flatfoot should be strongly discouraged for two very compelling reasons. Firstly, there is no evidence at all to show that the use of any form of shoe inserts or shoe modification corrects flatfoot. Secondly, in the light of evidence that shoe-wearing may actually be detrimental to development of the arch the wisdom of prescribing a modified shoe would be questionable. In the very rare situation where there is pain in the foot on standing or walking, an arch support may be worn.

#### Rigid Flatfoot

##### *Treatment Approach: Treat Electively*

The common cause for rigid flatfoot is tarsal coalition or an abnormal bony bar between two tarsal bones. The two most



**Figs 22.13A and B:** Oblique radiograph of the foot of a child with calcaneo-navicular coalition (A). The radiographic appearance of the same foot after excision of the coalition was performed (B)



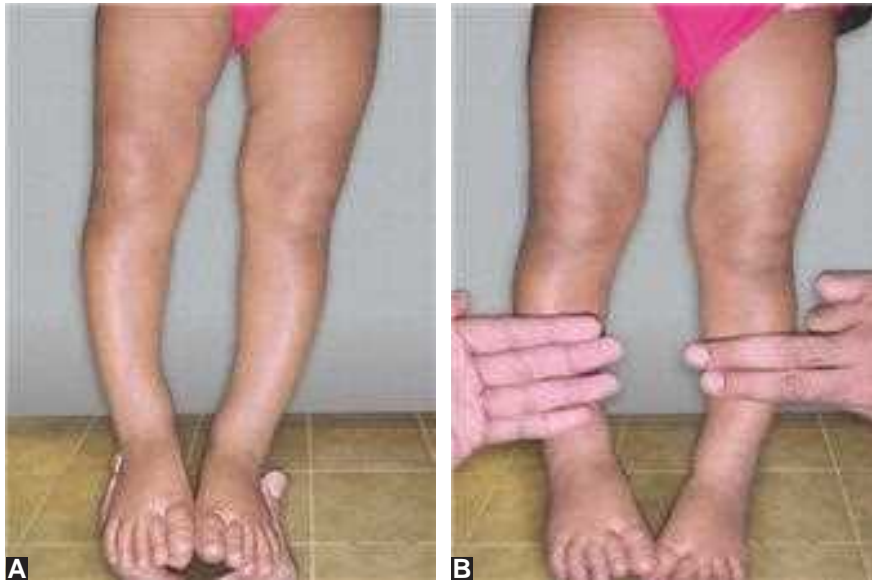
**Figs 22.14A and B:** Physiological genu varum (A) and genu valgum (B)

common coalitions are talo-calcaneal coalition and calcaneo-navicular coalition. The coalition may be cartilaginous to begin with and then may ossify. Pain often appears when the child reaches ten to twelve years of age. Examination will reveal that the arch cannot be restored by standing on tip-toe and that there is limitation of movement of the subtalar or mid-tarsal joints. Calcaneo-navicular coalitions can be demonstrated clearly on an oblique-view radiograph of the foot (Fig. 22.13A). CT scans may be needed to clearly demonstrate a talo-calcaneal coalition. If pain has developed the coalition can be excised and fat or muscle tissue needs to be interposed into the gap to prevent the coalition from reforming (Fig. 22.13B). This form of surgery usually relieves pain but the movements of the subtalar and mid-tarsal joints are seldom restored to normal. Occasionally, painful arthritis may develop in the adjacent joints; excision of the coalition will be ineffective at this stage and the arthritic joint would need to be arthrodesed.

### Physiological Genu Varum and Genu Valgum

#### *Treatment Approach: Reassurance*

Several children between the ages of one and three years have genu varum (bow-legs) and children between three and seven years of age often have genu valgum (knock-knees). These deformities spontaneously resolve completely in the vast majority of instances and hence are referred to as physiological genu varum and valgum (Figs 22.14A and B). However, one needs to be certain that the deformities are not due to any underlying pathology. Among the various causes of genu varum and valgum, rickets is a common cause in developing countries and must be excluded before assuming that one is dealing with physiological genu varum or valgum. Plain radiographs and biochemical investigations can exclude active rickets. Physiological genu varum also needs to be differentiated from infantile Blount's disease which requires early treatment. A clinical sign that appears



**Figs 22.15A and B:** The cover-up test showing valgus alignment of the proximal tibia in a child with bow-legs. This indicates that the child does not have Blount's disease

to be quite reliable in making this distinction is the cover-up test (Figs 22.15A and B). While the examiner covers the middle and lower third of the bowed leg with the palm the alignment of the proximal third of the leg in relation to the thigh is noted. If the proximal third of the leg is in valgus, Blount's disease is excluded.

Children with physiological genu varum and valgum need to be periodically reviewed to ensure that resolution of the deformity is occurring. The parents can be reassured that the deformity is likely to correct over time. Bracing, night splints and shoe modification have no effect on the natural history of these deformities and are not warranted.

### Adolescent Idiopathic Scoliosis

#### *Treatment Approach: Treat Early*

Scoliosis or lateral bending of the vertebral column often develops in adolescent girls. The deformity is not merely lateral curvature of the spine but has rotational and sagittal plane components also. The rotation of the spinal column results in an asymmetry of the rib cage; a prominence or rib hump develops on the side of the convexity of the spinal curvature. It is the rib hump that attracts the attention of the parents. The deformity tends to progress during the pubertal growth spurt. If diagnosed early, spinal instrumentation and fusion can correct the deformity satisfactorily. However, if treatment is delayed, surgery may succeed in reducing the deformity but seldom completely corrects it. For this reason the diagnosis needs to be made early. In conservative



**Fig. 22.16:** Forward bending test used to detect scoliosis. The rib hump that is evident indicates that there is thoracic scoliosis

societies where it is uncommon for the parents or friends to see the adolescent girl's bare back the diagnosis may be delayed till the rib hump is severe enough to attract attention through the girl's loose clothing. For this reason, school-screening for scoliosis is recommended. The screening test is the forward bending test where each student bends forwards and the examiner views the back to identify a rib hump (Fig. 22.16).

## PARALYTIC CONDITIONS

### Obstetric Brachial Plexus Palsy

#### *Treatment Approach: Treat Early*

Injury to the brachial plexus commonly follows shoulder dystocia during labour. Loss of spontaneous movements of the upper limb would be apparent soon after birth. Often what initially appears to be a whole-arm type of paralysis will turn out to be a more localised paralysis; most commonly the upper two roots (C5 and C6) or the upper trunk of the brachial plexus is involved. The severity and the location of the injury determine the extent of recovery. If the injury involves avulsion of the roots of the plexus within the spinal canal (preganglionic injury) no recovery can be anticipated, while if the injury is an extraforaminal (post-ganglionic) neuropraxia complete recovery can be anticipated. Electrodiagnostic tests are unreliable in accurately differentiating between the different grades of severity of injury in the first few weeks and hence are not recommended. A careful clinical recording of the muscle function of each muscle group is made periodically to map the recovery. If shoulder abduction and elbow flexion of more than Grade III power (antigravity function) is restored within two months of birth the prognosis for full recovery is excellent. If antigravity function of the elbow flexors is restored by three to six months some useful recovery of function would occur. However, if no elbow flexor power is restored within three months the prognosis for recovery is poor. In such a child electrodiagnostic tests need to be done at this stage to determine if the injury is preganglionic or post-ganglionic and exploration and repair of the brachial plexus needs to be considered.

Fortunately, in the majority of instances elbow flexor power does return by three months. Several of these children will have some residual weakness and many develop contractures of the shoulder. The commonest contracture that develops is an internal rotation contracture, which can result in posterior dislocation of the shoulder. Since these contractures can develop within a few months, it is imperative that passive stretching exercises to prevent contractures are begun soon after birth and continued regularly for several months. In the past, splints that held the arm abducted and externally rotated were used but currently no form of splintage is recommended. If an internal rotation contracture develops, it needs to be identified early and surgery done in order to correct it and prevent it from going on to produce a dislocation of the shoulder.

### Poliomyelitis

#### *Treatment Approach: Treat Electively*

Though the incidence of polio has reduced in most parts of the developing world, children with post-polio residual

paralysis would be encountered for several years to come. The vast majority of children with post-polio residual paralysis have deformities in addition to paralysis. The two causes of deformity in these children are abnormal posture and muscle imbalance. It follows that deformities in polio can be prevented by ensuring proper posture and by recognizing muscle imbalance early and restoring muscle balance before the deformity develops. The fact that most children do develop deformities clearly indicates that sufficient attention has not been paid to prevention of deformities.

#### *Prevention of Deformities*

During the acute paralytic phase of polio, the paediatric orthopaedic surgeon should be involved in planning appropriate bracing to prevent postural deformities. During the stage of recovery again bracing of the paralysed extremity can minimize the onset of deformity. Once the stage of recovery is over, careful muscle charting needs to be done in order to identify if muscle imbalance exists. At this stage, if muscle balance is restored by surgery, deformities can be avoided.

#### *Correction of Established Deformities*

Deformities secondary to poor posture result in contracture of fascia, muscles and joint capsules. Muscle imbalance primarily results in joint deformity due to contracture of the stronger muscle group acting on the joint. Secondly, the joint capsule may get contracted. If the deformity remains uncorrected adaptive bony changes take place. This emphasizes the need to intervene before bony changes develop.

The milder degrees of deformity will get corrected by releasing the contracted fascia and lengthening the tendons of the contracted muscles. In moderately severe deformities the contracted capsule would also have to be released; additional osteotomies of the bone adjacent to the joint would be needed to correct severe deformities.

#### *Dealing with Paralysis*

The best option for restoring function of a paralysed muscle is to perform a tendon transfer. However, in order to do so, a muscle that is transferred should have normal (Grade V) muscle power and transferring the muscle should not cause secondary disability. Tendon transfers are most commonly done around the foot and ankle in polio.

#### *Treating Joint Instability*

When all the muscles acting on a joint are paralysed, the joint is rendered flail and unstable. Unstable joints need to be stabilised either externally by the use of an orthosis or by fusing the joint. Such an intentional fusion of a joint is referred to as an arthrodesis.

## Bracing

If there are no muscles available to consider a tendon transfer, an orthosis may be needed to facilitate ambulation. The extent of bracing would depend on the extent of paralysis. An orthosis that stabilizes the paralysed foot and ankle (below-knee brace) is referred to as an ankle-foot orthosis or AFO; an orthosis that stabilises the knee, ankle and foot is called a knee-ankle-foot orthosis or KAFO. In the past, these braces were made of metal uprights and leather belts. Currently they are made of light-weight thermoplastic materials like polypropylene.

## Spina Bifida

*Treatment Approach: Treat Early  
(Incipient Neuropathic Ulcer: Treat Urgently)*

Spina bifida is primarily a congenital anomaly of development of the neural tube. Secondly the neural arches of the vertebrae at the level of the neural tube defect fail to fuse in the midline. Either the meninges alone bulge through the vertebral defect (meningocele) or neural tissue of the spinal cord and the meninges protrude through the defect (myelomeningocele) (Fig. 22.17). Varying degrees of neurological deficit will be present in these children depending on the level of the defect. Motor deficit, sensory loss and autonomic dysfunction, that affects bowel and bladder continence, may all be present in children with myelomeningocele.

The level of the neurological damage, to a large extent, determines the likelihood of the children retaining their ability to walk outside their homes in adult life (community ambulators). In general, if the child has functioning quadriceps muscles of both lower limbs, the potential for remaining a community ambulator is good. If, however, the level of the damage is higher and the quadriceps muscles are paralysed, the child is likely to end up in a wheel chair by adolescence even if the child does walk with braces in early childhood.

## Management of Paralysis

The management of paralysis in children with spina bifida is very similar to that in polio. Wherever tendon transfers are feasible, they should be considered and when there are no tendons available for transfer bracing is needed.

## Correction of Deformities

In spina bifida, deformities of the spine, hips, knees and feet are all common. Scoliosis and kyphosis occur frequently in these children and their management is particularly difficult. Once the scoliosis becomes severe sitting balance may be lost and the child may only be able to sit with the support of both

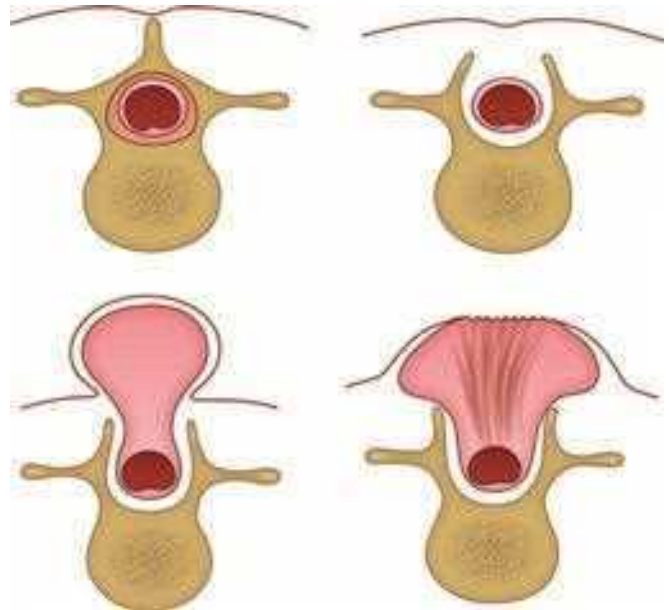


Fig. 22.17: Meningocele in a newborn infant

hands on the cot or chair. The scoliosis must be corrected if this happens or else the child would not be able to use the hands for any other useful activity while seated.

The deformities of the lower limbs in spina bifida again are largely due to muscle imbalance. These deformities can be minimised if muscle balance is restored by appropriate surgery.

In a child who is wheel chair bound, any deformity of the lower limb that precludes sitting should be corrected. In a child who needs to use an orthosis, any deformity that interferes with the fitting of the orthosis must be corrected. Any deformity of the foot that prevents the foot from resting flat on the ground (plantigrade tread) should be corrected in all children with spina bifida who can walk.

## Preventing Neuropathic Ulcers

One of the most distressing complications of spina bifida is neuropathic ulceration or pressure sores. These occur in regions of sensory loss over bony prominences. The two common regions where these ulcers develop are the ischial region and the soles of the feet. It is important to understand how these ulcers develop and plan strategies to prevent them because getting an ulcer to heal once it develops is often very difficult. If the ulcer does not heal the underlying bone can get infected (Fig. 22.18).

Neuropathic ulcers develop when insensate tissue overlying a bony prominence is either subjected to excessive pressure or to shearing forces. Since pressure is force per unit area any reduction in the area of contact will result in excessive pressure. This is typically seen when the foot is deformed and not plantigrade; the entire sole will not rest on





**Fig. 22.18:** Radiograph of a child with spina bifida who developed osteomyelitis of the calcaneum

the ground. Since a smaller area of the sole rests on the ground when the foot is deformed, greater pressure is borne on the sole than when the child stands on a normal plantigrade foot. Hence it is vitally important to correct any deformity that may be present and restore a plantigrade tread. However, it is also important to be aware that operations performed to get the foot plantigrade should not make any joint of the foot stiff. It is important to restore a plantigrade tread while retaining the suppleness of the foot. This is because the frequency of neuropathic ulceration is high if the feet are stiff and rigid even if they are plantigrade.

Similarly, a lumbar scoliosis will cause pelvic obliquity and then more pressure will fall on the ischial tuberosity that is lower when the child is seated and this increases the risk of development of an ischial pressure sore. This underscores the importance of correcting the spinal deformity to overcome the pelvic obliquity.

The second factor that can cause a neuropathic ulcer is shearing forces on tissue overlying a bony prominence. If a child shuffles on its bottom the tissue overlying the ischial tuberosity is subjected to shearing forces and so it is important to educate the parents of the potential risk of ulceration and ensure that the child does not bottom-shuffle. Another example of a situation where shearing forces cause neuropathic ulceration is a calcaneus deformity in an ambulant child. A child with paralysed plantarflexors of the ankle with functioning dorsiflexors will develop a calcaneus deformity. When such a child walks, there is uncontrolled dorsiflexion of the foot during the latter part of the stance phase of gait; quite significant shearing forces develop under the heel when this occurs. Consequently, these children are very prone to develop ulcers on the heel (Fig. 22.19).

Apart from correcting deformities that predispose to neuropathic ulcers and avoiding activity that can cause

abnormal stresses on the insensate tissue in susceptible areas, the parents and the child need to be educated about the care of the anaesthetic regions. Children with anaesthetic feet should use soft-lined foot wear and should not walk without this foot wear. Any orthotic that is used should be lined with soft lining material. Parents (and children who are old enough to cooperate) should be taught to inspect the soles of the feet every day. If redness or early blistering is noted, a day's bed rest should be enforced to enable the incipient ulcer to heal. If the redness does not resolve with rest the orthopaedic surgeon must be consulted immediately.

## Cerebral Palsy

### *Treatment Approach: Treat Early*

Though the motor system involvement in cerebral palsy is the most overt, it is extremely important to note that there are several other impairments in children with cerebral palsy including speech defects, visual disturbances, hearing defects, behavioural disorders and epilepsy. Several of these associated impairments often need to be addressed before dealing with the motor deficit (These issues are dealt with in Chapter 18).

Motor system involvement in cerebral palsy compromises upper limb function and the activities of daily living (ADL). Involvement of the lower limb in cerebral palsy results in abnormalities of gait. The manifestations of motor system damage include spasticity, in-coordination, paresis, muscle imbalance, lack of selective motor control and involuntary movements. Uncontrolled spasticity will lead to contracture of the spastic muscle and this in turn will lead to deformities.



**Fig. 22.19:** Neuropathic ulcer of the heel in a child with spina bifida and paralysis of the gastrocnemius

Among these specific problems, spasticity, muscle imbalance and deformities can be modulated by treatment. It needs to be emphasised that treatment can frequently improve these problems but the function can never be made normal.

The ideal aim of treatment of cerebral palsy is to make the child totally independent. However, in several instances this may not be feasible. It is important to clearly spell out the aims of treatment and communicate these aims to the parents of the child. Every effort must be made to minimize dependence in children who cannot be made totally independent. In children who are severely affected and are likely to remain totally dependent for life, the aim of treatment would be to facilitate care of the child and to make the caregiver's job a bit easier. In addition to these aims of treatment, in all children with cerebral palsy complications such as hip dislocation should be prevented.

### Management of Spasticity

There are several ways to reduce spasticity of muscles. These include physiotherapy, myoneural blocks, oral or intrathecal medication, splinting and casting, surgery on the muscles and tendons and neurosurgical procedures such as selective dorsal rhizotomy. Among these different options, physiotherapy, myoneural blocks and surgery on muscles and tendons are the most widely used.

Physiotherapy needs to be done every day throughout the period of growth. The need for regular physiotherapy till skeletal maturity needs to be emphasised at the outset. Often parents abandon physiotherapy when they do not see any dramatic improvement. The compliance can be improved if the patients are reviewed on a regular basis in a special clinic. This would give the opportunity to remind the parents for the need for pursuing with physiotherapy; and interaction with parents of other children can also have very positive effect in this regard.

Myoneural blocks either into the muscle belly or in the vicinity of the nerve supplying the spastic muscle can appreciably reduce spasticity. Currently injection of Botulinum toxin into the muscle at the motor point is widely practiced. This reduces spasticity and the effect lasts up to six months or more. Unfortunately the cost of Botulinum toxin is prohibitive. Alcohol (40%) has a comparable effect and is a great deal cheaper.

The aim of surgery on the muscles or tendons is to weaken the spastic overactive muscles. The force of muscle contraction can be reduced if the resting length of the muscle fibers can be reduced and this can be achieved by either lengthening the tendon or aponeurotic insertion of the muscle or by erasing the muscle from its origin and permitting the muscle to slide distally.

### Restoring Muscle Balance

Spastic muscles that are overactive cause reciprocal inhibition of the antagonistic muscles and this results in muscle imbalance. Once the spastic muscle is weakened, the antagonistic muscle can be strengthened by physiotherapy.

## INFECTIONS OF BONE AND JOINTS

### Acute Septic Arthritis

#### Treatment Approach: Treat Urgently

Acute septic arthritis is a surgical emergency that develops following haematogenous seeding of bacteria in the synovium. The bacteria and the macrophages secrete very potent proteolytic enzymes which can degrade and destroy hyaline cartilage of the articular surfaces, the epiphysis and the growth plate. Enzymatic degradation of cartilage can begin within eight hours of colonisation of bacteria in the synovial tissue. If adequate treatment is delayed beyond three days after the onset of symptoms damage to the joint is almost inevitable (Fig. 22.20).

The most common causative organism is *Staphylococcus aureus*. Neonates and children under the age of five years are most susceptible to developing septic arthritis, though septic arthritis can occur at any age. The hip and the knee are the most commonly involved joints. In neonates it is not uncommon to have more than one joint simultaneously affected.



**Fig. 22.20:** Destruction of the head and neck of the femur following acute septic arthritis in infancy

In neonates the most common presentation is pseudoparalysis; no spontaneous movement of the affected limb will be seen. True paralysis, fracture of a bone in the limb or septic arthritis may all present with lack of spontaneous movement of the limb. A careful examination can help the clinician to differentiate these conditions. Attempting passive movement of the affected joint causes the baby to cry and there may be some swelling around the joint.

X-rays and other imaging modalities are not helpful in confirming the diagnosis of septic arthritis. Similarly, no laboratory test apart from actual demonstration of bacteria in the synovial fluid is diagnostic of septic arthritis. In a sizeable proportion of cases of true septic arthritis bacteria may not be demonstrable on a Gram's stain of the synovial fluid and on culture. On account of the unreliability of laboratory tests and imaging studies in confirming the diagnosis of septic arthritis, treatment needs to be instituted on the basis of the clinical features. Treatment should not be withheld for want of laboratory confirmation.

Intravenous antibiotics that are effective against Staphylococci should be started immediately. If clear improvement in the swelling of the joint and reduction in pain on passive movement are not noted within 8 to 12 hours the joint must be explored and drained. Lavage of the joint with copious quantity of saline at the time of surgery will help to reduce the bacterial load. Joints such as the hip that have a propensity to dislocate need to be immobilised in a plaster cast for a few weeks while other infected joints should be immobilised till the inflammation subsides. The intravenous antibiotics may be replaced by oral antibiotics once clinical improvement is noted.

### Acute Osteomyelitis

#### *Treatment Approach: Treat Urgently*

Acute pyogenic osteomyelitis again most commonly is due to haematogenous spread of bacteria from a source elsewhere in the body. The infection starts in the metaphysis due to peculiarities of the blood vessels in this region. If the infection is not controlled, pus will collect in the metaphysis and then track under the periosteum. Gradually, pus will fill the entire medullary cavity and the endosteal blood vessels will get occluded. At the same time the periosteum will get elevated circumferentially over the entire length of the diaphysis by pus, resulting in loss of the periosteal blood supply to the cortex. The diaphysis which now is devoid of both endosteal and periosteal sources of blood supply will undergo necrosis and become a sequestrum. It is of paramount importance to diagnose osteomyelitis early and prevent this catastrophic complication.

The femur and tibia are most commonly affected. If the metaphysis is situated within a joint, as in the proximal

femur, arthritis may ensue very soon and then the clinical features would be those of the arthritis.

The initial mode of presentation in neonates is the same as for acute septic arthritis—as pseudoparalysis. Careful examination of a child with acute osteomyelitis may demonstrate tenderness in the region of the metaphysis with no aggravation of pain on gently moving the adjacent joint. As in the case of septic arthritis, imaging modalities and laboratory investigations are not useful in the first few days after the onset of osteomyelitis. Aspiration of the metaphysis with a wide-bore needle may yield pus if frank suppuration has begun. Ultrasonography and MRI scans can delineate the extent of a sub-periosteal abscess if it has formed. However, ideally a diagnosis of acute osteomyelitis should be made on clinical grounds even before the sub-periosteal abscess forms and appropriate treatment should be instituted without any delay. Intravenous antibiotics that are effective against the most likely pathogens should be started immediately. Staphylococci are the most common group of organisms responsible for acute haematogenous osteomyelitis, while in children with sickle cell disease, Salmonella may be the causative organism. If the pain and fever subside and the local warmth and tenderness reduce within 24 to 48 hours, antibiotics and bed rest may suffice. If, on the other hand, there is no definite clinical improvement within 48 hours, surgery should be undertaken. The involved metaphysis (the diaphysis in Salmonella osteomyelitis) is explored. If a sub-periosteal abscess is present, it is drained. A couple of drill holes are made in the underlying bone and a small quantity of pus may exude through the drill holes. This serves as effective decompression of the bone if the infection is localised. If a large quantity of pus is evacuated, a small cortical window is made in the bone to facilitate irrigation of the medullary cavity. The limb is protected in a plaster of Paris cast to prevent a pathological fracture. Once clinical improvement is documented intravenous antibiotics may be replaced by oral antibiotics which are then continued for four to six weeks.

## INHERITED DISORDERS OF BONE

### Osteogenesis Imperfecta

#### *Treatment Approach: Treat Electively*

Osteogenesis imperfecta is an inherited disorder of the skeleton characterised by frequent fractures. The frequency of fractures varies with the severity of the disease. There may be associated ligament laxity, blue sclera and abnormal dentition. In the most severe variety, fractures occur in-utero and the baby is often still born. In the less severe varieties fractures may commence soon after birth and in the mild form may not occur till early childhood. The child may be unable to stand or walk as the femur or tibia may fracture.



**Fig. 22.21:** Severe deformities of the femur and tibia seen in osteogenesis imperfecta



**Fig. 22.22:** Fractures in osteogenesis imperfecta can be minimised by inserting intra-medullary rods into the long bones

The fractures often mal-unite and over a period of time quite horrendous deformities may develop (Fig. 22.21). Generalised bone pains and the pain of repeated fractures make the quality of life very poor.

Bisphosphonates appear to reduce the pain and the frequency of fractures. In addition, correction of the deformities and insertion of rods into the medullary cavity of the bones of the limbs markedly reduce the frequency of fractures (Fig. 22.22). Since the bones outgrow the rods as the child grows the rods would have to be removed and longer rods need to be inserted or else, fractures will occur in the unsupported part of the bone. The propensity for fractures tends to reduce as the child approaches skeletal maturity.

## Skeletal Dysplasias

### *Treatment Approach: Treat Electively*

Skeletal dysplasias include a large variety of genetically determined abnormalities of the skeleton that manifest as abnormalities in growth of part or the entire skeleton. In some forms, the appendicular skeleton is predominantly involved with little abnormality in the spine, while in other forms both the axial skeleton and the limbs are involved. The pattern of involvement of the skeleton varies with the form of skeletal dysplasia. In some forms the proximal segments (femur and humerus) are most affected, while in other forms the tibia, fibula, radius and ulna are the most severely affected and in a few types, the hands and feet are most affected. The abnormalities of growth may also



**Fig. 22.23:** Deformity of the knee seen in a form of skeletal dysplasia

result in dwarfism or angular deformities due to asymmetric growth at the growth plates of long bones (Fig. 22.23). These deformities result in abnormal stresses on joints and this contributes to very early onset of secondary degenerative arthritis of the weight-bearing joints. In addition to aberrant growth, joint instability or joint stiffness may be present in some dysplasias.



**Fig. 22.24:** Multiple osteochondromata seen in the distal femur and proximal tibia of both limbs

Whenever there is evidence of dwarfism or abnormal body proportions radiographs of the skeleton need to be obtained to exclude skeletal dysplasia. Some skeletal dysplasias can be diagnosed at birth (e.g. achondroplasia) while in some dysplasias the growth abnormality may only become evident in early or even late childhood (e.g. spondylo-epiphyseal dysplasia tarda). Orthopaedic intervention for skeletal dysplasia in childhood is mainly to correct deformities.

## TUMOURS OF BONE

### Benign Tumours

*Treatment Approach: Treat Electively*

One of the common benign tumours of bone is osteochondroma, which as the name implies has a cartilaginous and a bony component. The tumour typically occurs in the metaphyseal region of long bones and may be either solitary or multiple (Fig. 22.24). Multiple osteochondromatosis is an inherited disorder which is associated with a remodeling defect of the long bones and growth abnormalities. The solitary variety, on the other hand is not associated with growth abnormalities or a remodeling defect. The osteochondromata grow till skeletal maturity and then cease to grow unless they have undergone malignant transformation. Malignant transformation to a chondrosarcoma is very rare in solitary osteochondromas but may occur in about 10% of patients with multiple osteochondromatosis. Unless the osteochondroma causes pressure on an adjacent nerve or impairs movement of a joint it can be left alone. If symptoms warrant it, the osteochondroma may be excised along with the periosteum surrounding the base of the osteochondroma.



**Figs 22.25A and B:** Radiographic appearance of Ewing's tumour (A) and osteosarcoma (B)

### Malignant Tumours

*Treatment Approach: Treat Urgently*

The two important malignant tumours of bone seen in children are osteosarcoma and Ewing's tumour. Ewing's tumour occurs most commonly in the first decade of life while osteosarcoma occurs in the second decade of life. The presenting features may be pain or swelling in the thigh, leg or arm which are the common sites for these tumour to occur. Unexplained pain or swelling of the limb should be investigated carefully. A radiograph of the limb is mandatory and if either of these tumours is present, characteristic changes may be seen. In the case of Ewing's tumour, a lesion would be seen more commonly in the diaphysis with areas of patchy osteolysis, cortical erosion and periosteal reaction that may have a very typical "onion peel" appearance (Fig. 22.25A). Osteosarcoma, on the other hand is metaphyseal and the lesion is predominantly sclerotic in appearance; early breach of the cortex with extension of the tumour under the periosteum produces a typical "sun ray" appearance (Fig. 22.25B). Though these radiographic appearances are quite characteristic of these tumours, similar appearances can occur in other less morbid conditions. Radiographic changes in the bone that are similar to those of Ewing's tumour may occur in osteomyelitis, while changes akin to those of osteosarcoma may occur with exuberant callus formation after a fracture in spina bifida or osteogenesis imperfecta. Therefore, it is mandatory to perform a biopsy to confirm the diagnosis. Unless a pathologist who is experienced in interpreting needle biopsies is available, it is preferable to perform an open biopsy.

**Table 22.8:** The typical ages at which painful conditions of the hip occur

Condition	Common age at presentation
Septic arthritis	Under 5 years
Transient synovitis	5 to 10 years
Perthes' disease	5 to 12 years
Slipped capital femoral epiphysis	12 to 15 years

Ewing's tumour is treated with cyclical chemotherapy and in some instances with additional radiotherapy and surgery. Osteosarcoma is treated with adjuvant chemotherapy followed by surgery. If strict criteria are fulfilled, limb salvage surgery may be considered or else an amputation is performed. Cyclical chemotherapy is resumed again following surgery. Limb salvage surgery would require some form of reconstruction after resection of the diseased bone segment.

## HIP PAIN IN CHILDREN AND ADOLESCENCE

Among all the joints of the body that may be a source of pain in children, the hip joint is most frequently affected. Apart from trauma and bone and joint infection, there are some other causes of hip pain that warrant a brief mention; these include transient synovitis, Perthes' disease and slipped capital femoral epiphysis. The age at which each of these conditions occurs varies (Table 22.8) and the knowledge of the typical ages at presentation can alert the clinician to the possible diagnosis. Though the pathology in these conditions is in the hip, the child may complain of pain in the knee as pain arising from the hip may be referred to the knee. This emphasizes the need to carefully examine the hip in addition to examining the knee when a child complains of knee pain.

### Transient Synovitis

*Treatment Approach: Treat Early*

Transient synovitis affects children between 5 and 10 years of age. The child presents with a limp and pain in the hip or knee. The onset of pain may be preceded by an upper respiratory infection in a proportion of cases. Extremes of hip movement are painful and there may be a mild flexion or abduction deformity. All these signs point to the presence of an effusion in the hip which can be clearly demonstrated by ultrasonography. The clinical features, including the absence of fever, normal blood counts and ESR help to exclude septic arthritis. A few days of bed rest and traction usually relieves the pain completely and the synovitis settles without any permanent sequelae. However, since Perthes' disease may present in the same manner in the very early stages, these children should be followed up with a radiograph of the hips after six to eight weeks to see if the changes of Perthes' disease are visible.



**Fig 22.26:** Radiographic appearance of a boy with Perthes' disease. The epiphysis is sclerotic and flattened

### Perthes' Disease

*Treatment Approach: Treat Early*

Perthes' disease is a form of osteochondrosis that affects the capital femoral epiphysis (Fig. 22.26). Part or all of the femoral epiphysis becomes avascular, the precise cause of which is unknown; the blood supply gets restored spontaneously over a period of two to four years. The prevalence of Perthes' disease varies profoundly from region to region. In India, the disease is exceedingly common in the south-west coastal plain but is quite uncommon in other parts of the country. In India, the disease affects children mainly between the ages of 5 and 12 years; the peak age at onset of symptoms is around 9 years. This is distinctly older than the age of onset reported in the Western literature. The classical presentation is with a limp and pain of insidious onset and moderate limitation of passive abduction and internal rotation of the hip. The X-rays will show characteristic changes of flattening and sclerosis of the capital femoral epiphysis. In the younger child the prognosis is generally good; the blood supply gets restored and healing of the epiphysis occurs without any deformation of the femoral head. In the older child, however, the femoral head tends to get deformed during the process of healing. Consequently, surgery aimed at preventing femoral head deformation is often needed in the older child. It is important that such surgery is performed early in the course of the disease if it is to be effective. If the femoral head does get deformed, secondary degenerative arthritis may develop by the third or fourth decades of life.

### Slipped Capital Femoral Epiphysis

*Treatment Approach: Treat Urgently*

Slipped capital femoral epiphysis or adolescent coxa vara occurs commonly between 12 and 15 years of age. There may be an underlying endocrine disorder or chronic renal disease in a proportion of these patients and it is important



**Figs 22.27A and B:** The appearance of a slipped capital femoral epiphysis in an adolescent

that these are excluded. Majority of the patients are obese though the epiphyseal slip can occur in children with a normal body habitus.

The growth plate of the proximal femur gets disrupted and the epiphysis slips medially and posteriorly off the neck of the femur (Figs 22.27A and B). The slip is heralded by pain in the hip and in the majority of instances tends to occur gradually. The patient continues to walk albeit with a limp and the slip is referred to as a stable slip. On the other hand, if the slip occurs suddenly the pain is severe and the patient will be unable to bear weight on the limb; this is an unstable slip. Complications are far more common in patients with unstable slips and hence the importance of this classification. Complications of slipped femoral epiphysis

include progression of the slip, avascular necrosis of the femoral epiphysis and chondrolysis which results in extreme hip stiffness. Secondary, degenerative arthritis may occur in early adult life. The aim of treatment is to prevent the slip from progressing and to prevent other complications listed above. Since the risk of complications increase with delay in treatment, it is recommended that the femoral epiphysis is fixed to the femoral neck with a screw as soon as possible. There is a risk that a slip can occur in the opposite hip and because of this some surgeons fix the opposite epiphysis also prophylactically. If prophylactic fixation of the unaffected hip is not done, these patients should be periodically reviewed to ensure that a slip of the epiphysis has not occurred in the second hip.

# Paediatric Dentistry

## DENTAL ANATOMY

### Introduction

The teeth start to form during the fifth week of embryonic life, and the process of tooth formation continues until the roots of the third permanent molars are completed at about the age of 20 years. The stages of tooth formation are the same whether the tooth is of the primary or the permanent dentition.

The tooth is composed of an enamel crown covering an inner layer of dentine, which also forms the root. The external surface of the root is covered in cementum into which the periodontal ligament is attached; the insertion of this ligament is into the alveolar bone. The innermost part of the tooth has vital tissue, and is known as the pulp.

### Primary Dentition

The sequence and timing of eruption of the primary dentition has great individual variation (Fig. 23.1). The first tooth to erupt is usually the lower central incisor, which can sometimes be present at birth; the average age for its eruption is between 4 and 8 months. The upper central incisors erupt

at about 10 months followed by the upper lateral incisors at 11 months, and the lower lateral incisors at 13 months. At about the age of 16 months, the first primary molars erupt followed by the primary canine teeth at 19 months. The second primary molars erupt around 27–29 months, and the lower teeth usually erupt before the uppers. In essence, there is an almost continuous process of tooth eruption between the ages of 4 and 29 months. Exfoliation is the process of elimination of primary teeth associated with the eruptive process of the permanent successor at the apex of the primary tooth root. The eruptive process stimulates the development of osteoclasts which lead to a progressive resorption of the primary tooth root, dentine, and cementum.

### Permanent Dentition

The permanent dentition erupts in two stages (Fig. 23.2). The lower central incisor and the first permanent molars erupt at about the age of 6 years. The upper central incisor and the lower lateral incisor erupt at about the age of 7 years, and the upper lateral incisor at about the age of 8 years. As with the primary teeth, while some variation in the timing of tooth eruption is only to be expected, this eruption sequence should not vary. In particular, the upper central incisor should erupt before the upper lateral incisor. If the upper lateral incisor erupts before the central, then almost certainly, there is something impeding the eruption of the central incisor—for example: a supernumerary tooth, or dilaceration of the root of the central incisor.

The lower canine usually erupts at around 9 years followed by the premolar teeth at 10 years. The upper canine erupts at age 11 years with the second molar teeth at about the age of 12 years. Third molar teeth start to erupt from about the age of 16 years onwards, but the eruption of third molars is very variable; not uncommonly, these teeth are impacted against their neighbours, and fail to erupt at all; in many cases, they are congenitally absent.

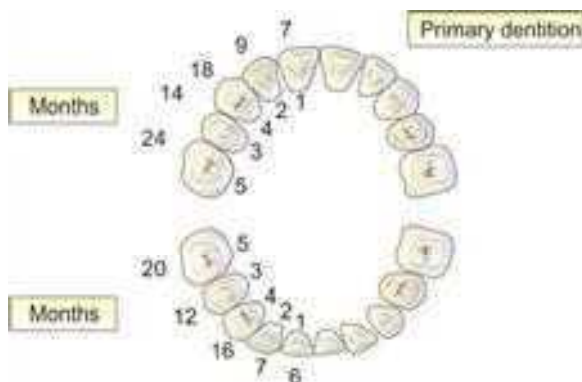


Fig. 23.1: Primary dentition eruption dates



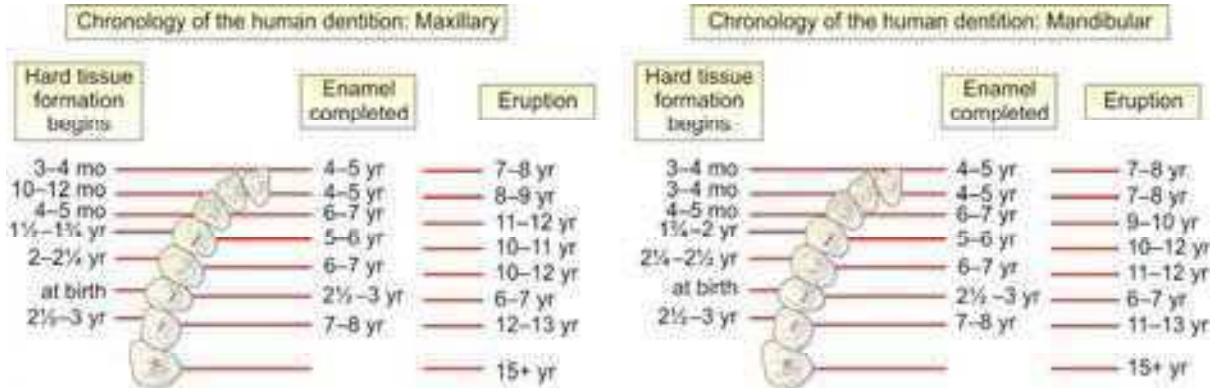


Fig. 23.2: Permanent dentition eruption dates



A



B

Figs 23.3A and B: Difference in appearance between primary and permanent dentition

### Differences between Primary and Permanent Teeth

In comparison to the permanent dentition, the crowns of the primary teeth are short, and the biting surfaces narrow (Figs 23.3A and B). They are bulbous in shape, and have thin enamel and dentine layers. The primary molars contact

of the enamel differs from permanent teeth. The roots of the primary teeth are long and slender in comparison to the crowns. They have a much larger pulp, which is closer to the outer surface.

### Problems Associated with Eruption

An eruption cyst presents as a bluish swelling of the gingivae (Fig. 23.4) prior to eruption of a tooth. These rarely require intervention, and spontaneously resolve on eruption of the tooth.

Ankylosis is caused by the fusion of the cementum of the root to the bone and accompanying loss of periodontal ligament attachment. Prevalence is between 7-14% in the primary dentition. The most commonly affected teeth are the mandibular primary first molar, mandibular primary second molar, maxillary first molar, and the maxillary primary second molar in that order (Figs 23.5A and B). This condition can lead to loss of arch length, extrusion of opposing teeth, and abnormal positioning of adjacent teeth.

Ectopic eruption is where the tooth, usually due to a deficiency of space, does not take up its normal position within the arch.





**Figs 23.5A and B:** (A) Infraocclusion of upper left primary molars; (B) Dental panoramic radiograph of same patient showing infraocclusion of primary molars in each quadrant

### Key Learning Points

- ➔ Teeth present at the time of birth, or in the neonatal period are usually teeth of the normal series which have just erupted early.
- ➔ The pattern of eruption of the primary dentition is very variable.
- ➔ The eruption sequence of the permanent dentition is very predictable, and investigations should be carried out should the child deviate from this pattern.

## CARIES

### Aetiology of Caries

Dental caries is one of the most prevalent diseases and yet, it is completely preventable.

Dental caries is caused by the fermentation of dietary sugars by microorganisms in plaque on the tooth surface; this produces acid. Rapid acid formation lowers the pH of the mouth, and dissolves the enamel. When sugar is no longer available to the plaque microorganisms, the pH within plaque will rise due to the outward diffusion of acids and their metabolism and neutralization in plaque so that remineralisation of enamel can occur; enamel caries progresses only when demineralisation is greater than remineralisation.

Dental plaque forms on tooth surfaces that are not properly cleaned. Dental plaque is made up of about 70% microorganisms. The types of microorganism present in the plaque change with its increasing age. When plaque is young, cocci predominate but as plaque ages, the proportions of filamentous organisms and veillonellae increase. Diet influences the composition of the plaque flora; considerably, with mutants streptococci much more numerous when the diet is rich in extrinsic sugar. If the process of dental caries

that it will crumble to leave a cavity. Once a cavity is formed, the process of dental caries continues in a more sheltered environment, and the protein matrix of dentine is removed by proteolytic enzymes produced by plaque organisms. In the general population, it commonly takes 2–4 years for caries to progress through enamel into dentine.

### Caries Prevention

The most important of the natural defences against dental caries is saliva. If salivary flow is impaired, dental caries can progress very rapidly. Saliva physically washes away food debris and sugars; it neutralises acids from the diet and those produced by plaque organisms; it also has antibacterial properties.

In terms of preventive treatment, the patient should receive: dietary advice to reduce the amount and especially the frequency of sugary intakes; instruction on effective tooth cleaning; and advice on fluoride intake as fluoride incorporation into the enamel structure of the tooth is the most important chemical intervention that can be made. In some cases, it is possible to restoratively seal the vulnerable surfaces of the tooth to prevent ingress of bacteria (fissure sealants).

Early caries is difficult to detect, as it is invisible to the eye. The first visible sign may be a faint white mark on the surface of the enamel (Fig. 23.6). As the process progresses, the area under the enamel becomes a dull brown colour, and as mineral loss under the surface extends, the surface layer becomes unsupported, and this eventually leads to breakdown and cavitation (Fig. 23.7).

Dental caries can be confused with developmental defects of tooth formation, and there are numerous causes of interruption of tooth development with defects varying from very minor whiteness of enamel to gross abnormalities of tooth structure (see tooth anomalies section).



**Fig. 23.6:** White demarcation of early decay



**Fig. 23.7:** Cavitation of primary dentition



**Fig. 23.8:** Early childhood caries

### Early Childhood Caries/Nursing Caries

This is a particular pattern of caries seen in very young children. It involves early caries of the upper incisor teeth along with the first primary molar in accord with the order of tooth eruption (Fig. 23.8). The disease is caused by

inappropriate bottle or breastfeeding. If the child takes a bottle filled with juice or sweetened milk, this will result in early caries. This is often compounded by inappropriate timing where the child is given access to this sweetened liquid around the clock, especially at night time when the substance may lie unswallowed in the mouth. At night, there is a decrease in the salivary flow rate and hence, decreased protection. Prolonged and constant breastfeeding at night may also cause this caries pattern, as human breast milk is cariogenic. The lower anterior teeth tend to be spared in nursing caries as they are covered by the tongue, and are washed in whatever saliva is available due to their proximity to the opening of the salivary glands.

Advice to give:

- All sweetened drinks should be consumed at mealtimes only
- Once a baby has been weaned, water should be the only night-time feed (after 12 months)
- For good dental health, all breastfeeding should be discontinued by 2 years
- Milk in bottle is safe for daytime feeds, but can cause caries if taken during the night.

#### Key Learning Points

- ➔ To prevent caries, reduce the amount and especially the frequency of consumption of sugar.
- ➔ Good oral hygiene and the incorporation of fluoride into the tooth surface will also help prevent caries.

## ORAL PATHOLOGY/ORAL MEDICINE

This section deals with those conditions that occur exclusively, or more commonly in children. It is not an exhaustive guide to paediatric oral pathology/medicine for which readers should refer to oral pathology/medicine textbooks.

### Oral Lesions in Neonates and Young Infants

#### *Bohn's Nodules*

These gingival cysts arise from remnants of the dental lamina (stage in early tooth formation). They are found in neonates and usually, disappear spontaneously in the early months of life (Fig. 23.9).

#### *Epstein's Pearls*

These small cystic lesions are located along the palatal midline, and are thought to arise from trapped epithelium in the palatal raphe. They are present in about 80% of neonates, and disappear within a few weeks of birth.



**Fig. 23.9:** Gingival cyst of the newborn



**Fig. 23.11:** Neonatal teeth causing ulceration of the tongue



**Fig. 23.10:** Congenital epulis



**Fig. 23.12:** Lower lip mucocele

### *Congenital Epulis*

This is a rare lesion that occurs in neonates, and normally presents in the anterior maxilla or mandible (Fig. 23.10). It consists of granular cells covered by epithelium, and is thought to be reactive in nature. It is benign, and simple excision is curative.

### *Melanotic Neuroectodermal Tumour*

This rare tumour occurs in the early months of life; usually, in the maxilla. The lesion consists of epithelial cells containing melanin with a fibrous stroma. Some localised bone expansion may occur. The condition is benign, and simple excision is curative.

### *Candidiasis*

Neonatal acute candidiasis (thrush) contracted during birth is not uncommon.

### *Natal/Neonatal Teeth*

Present at birth (Natal), or erupt within the first month of

erupted early, rarely supernumerary teeth (Fig. 23.11). Require removal if excessively mobile, causing traumatic ulceration, or preventing breastfeeding.

## **Pathological Findings in Children and Adolescents**

### *Mucocele*

The peak incidence of mucoceles is in the second decade of life; however, they are not uncommon in younger children including neonates. Mucoceles are caused by trauma to minor salivary glands or ducts, and are most commonly located on the lower lip (Fig. 23.12). They are the most common noninfective cause of salivary gland swelling in children, as salivary tumours are rare in this age group.

### *Ranula*

This is a bluish swelling of the floor of the mouth (Fig. 23.13). It is essentially a large mucocele, and may arise from part of



**Fig. 23.13:** Ranula



**Fig. 23.15:** Capillary haemangioma



**Fig. 23.14:** Cavernous haemangioma



**Fig. 23.16:** Sturge-Weber syndrome

### *Haemangioma*

Haemangiomas are relatively common in children. They are malformations of blood vessels, and are divided into cavernous (Fig. 23.14) and capillary (Fig. 23.15) variants, although, some lesions contain elements of both. Capillary haemangiomas may present as facial birthmarks. The cavernous haemangioma is a hazard during surgery if involved within the surgical site, as it is a large blood filled sinus which will bleed profusely if damaged. The extent of a cavernous haemangioma can be established prior to surgery using either angiography or MRI scanning. Small haemangiomas are readily treated by excision or cryotherapy. Larger lesions are amenable to laser therapy.

### *Sturge-Weber Syndrome*

Sturge-Weber angiomatosis is a syndrome consisting of a haemangioma of the leptomeninges with epithelial facial haemangioma closely related to the distribution of branches

hemiplegia and ocular defects can occur. Intraoral involvement may interfere with the timing of eruption of the teeth (both early and delayed eruption have been reported).

### *Lymphangioma*

Lymphangiomas are benign tumours of the lymphatics. The vast majority is found in children, and the head and neck region is a common site.

The cystic hygroma is a variant, which appears as a large neck swelling that may extend intraorally to involve the floor of the mouth and tongue.

Mixed haemangioma/lymphangiomas may also present (Fig. 23.17).

### *Fibrous Epulis/Fibroepithelial Polyp*

These lesions vary in appearance from red, shiny and soft enlargements of the oral mucosa to those that are pale, stippled, firm and pedunculated (Fig. 23.18). They usually



**Fig. 23.17:** Mixed haemangioma/lymphangioma



**Fig. 23.19:** Gingival overgrowth



**Fig. 23.18:** Fibroepithelial polyp



**Fig. 23.20:** Cleft palate

result of an initial traumatic incident or continued gingival irritation. Excision is usually indicated, and recurrence unlikely.

#### *Drug-induced Gingival Overgrowth*

The three drugs most commonly associated with the induction of gingival overgrowth (Fig. 23.19) are the anticonvulsant phenytoin, the immunosuppressant cyclosporine, and the calcium channel blocker nifedipine.

Poor oral hygiene exacerbates the overgrowth, which tends to appear interdentally 2–3 months following the introduction of the drug. Excellent oral hygiene is essential to minimise the effects but often, surgical excision will be required in patients whose medical condition does not allow for a change in drug regime.

#### *Dental Effects of Cleft Lip and Cleft Palate*

Aetiology and early surgical repair is discussed in Chapter 9.

These children should be under the care of a

children is dependent on the maintenance of a healthy dentition. Early advice regarding oral hygiene and non-cariogenic diet is essential if we are to instigate good lifelong habits; this advice is best started antenatally, or during the neonatal period. Children with clefts of the palate often have missing or extra teeth at the cleft site (Fig. 23.20). Teeth at this site may fail to erupt or erupt in an ectopic position due to lack of bone in the area. Many of these patients have very narrow palates as a result of surgical scarring and extensive orthodontic treatment for malocclusion is required.

#### *Orofacial Granulomatosis (Crohn's Disease)*

Orofacial granulomatosis (OFG) is not a tumour in the true sense nor a distinct disease entity, but describes a clinical appearance. Typically, there is diffuse swelling of one or both lips and cheeks (Fig. 23.21), folding of the buccal reflected mucosa and occasionally, gingival swelling and oral ulceration (Fig. 23.22). This may represent a localised disturbance due to an allergic reaction to foodstuffs. Treatment often includes avoidance of dietary allergens and



**Fig. 23.21:** Lip swelling in orofacial granulomatosis



**Fig. 23.22:** Gingival swelling in orofacial granulomatosis

Alternatively, the appearance may be due to an underlying systemic condition such as sarcoidosis or Crohn's disease. These patients may be prescribed various immunosuppressant drugs or offered surgery.

### *Melkersson-Rosenthal Syndrome*

This is a condition that generally begins during childhood, and consists of chronic facial swelling (usually the lips), facial nerve paralysis and fissured (scrotal) tongue.

### *Aphthous Ulceration*

Typically, these recurrent lesions are multiple, ovoid or round in shape, and have a yellow coloured depressed floor with inflamed border and commonly, are not associated with systemic disease (Fig. 23.23). Possible aetiology includes familial, immunological or microbial. One or more small ulcers in the non-attached gingivae may occur at frequent intervals.



**Fig. 23.23:** Aphthous ulceration at border of hard and soft palate

mistaken for toothache. Most aphthous ulcers in children are of the minor variety (less than 5 mm in diameter), and usually heal within 10–14 days. Occasionally, a child may present with major aphthae, which can be up to 10 mm in diameter, and persist for 2–3 weeks. Treatment other than reassurance is often not necessary; however, in severe cases, the use of topical steroids (adacortyl in orabase or betnesol mouthrinse) may be prescribed. Older children may benefit from the use of antiseptic and anti-inflammatory rinses to prevent secondary infection, and increase comfort. In the absence of a history of major aphthous ulceration, any ulcer lasting longer than 2 weeks should be regarded with suspicion and biopsied.

### *Traumatic Ulceration*

Traumatic ulceration of the tongue, lips and cheek may occur in children following the administration of local anaesthetic (Fig. 23.24).

### *Vesiculobullous Disorders*

Erythema multiforme (Fig. 23.25) can produce oral ulceration in children, and may be associated with viral infection or drug reaction. Oral lesions affect the lips and anterior oral mucosa, and distinctive lesions on the skin may also be present (Fig. 23.26). Initial erythema is followed by bullae formation and ulceration. Treatment includes the use of steroids, and oral antiseptic and analgesic rinses to ease the pain.

### *Epidermolysis Bullosa*

Epidermolysis bullosa is a term that covers a number of syndromes—some of which are incompatible with life. The skin is extremely fragile (Fig. 23.27), and mucosal involvement may occur. The act of suckling may induce



**Fig. 23.24:** Self-induced traumatic ulceration following local anaesthetic administration



**Fig. 23.27:** Skin fragility in epidermolysis bullosa



**Fig. 23.25:** Lip crusting in erythema multiforme



**Fig. 23.28:** Bullae formation on the tongue of patient with epidermolysis bullosa



**Fig. 23.26:** "Target" skin lesions in erythema multiforme

oral hygiene may be difficult; even mild trauma can produce painful lesions (Fig. 23.28).

The major vesiculobullous conditions such as pemphigus and pemphigoid are rare in young patients.

### White Lesions

- Chemical or physical trauma can lead to intraoral white lesions. Figure 23.29 shows the appearance of an aspirin burn
- A white sponge naevus (Fig. 23.30) is a benign lesion often detected in early infancy. It has a rough and folded appearance
- Leucoderma also has a folded appearance. It is a normal variant found in children of races who exhibit pigmentation of the oral mucosa
- Geographic tongue (Fig. 23.31) has the characteristic appearance of red patches surrounded by a white border. The red areas occur where there has been loss of the filiform papillae. The patches disappear and then reappear on other areas of the tongue. Spicy foods may cause discomfort but this is an otherwise symptomless condition of unknown aetiology for which reassurance should be given





**Fig. 23.29:** Aspirin burn in buccal mucosa



**Fig. 23.32:** Squamous cell papilloma



**Fig. 23.30:** White sponge naevus



**Fig. 23.33:** Giant cell granuloma



**Fig. 23.31:** Geographic tongue

## Tumours

- A squamous cell papilloma (Fig. 23.32) is a benign condition characterised by small cauliflower-like growths. These growths vary in colour from pink to white; are

- Verruca vulgaris (common warts) may present intra-orally. They are probably caused by the human papillomavirus.
- Focal epithelial hyperplasia is a rare condition also known as Heck's disease. It is associated with human papillomavirus, and presents as multiple small elevations of the oral mucosa especially in the lower lip.
- Giant cell granuloma (Fig. 23.33) is a dark red swelling of the gingivae. The peripheral form often arises interdentally, and radiographs may reveal some loss of interdental bone. The central giant cell granuloma shows much greater bone destruction. This condition is thought to be a reactive hyperplasia. Unless excision is complete, it will recur.
- Neurofibromas may present as solitary or multiple lesions. They are considered hamartomas, and present intra-orally as mucosal swellings on the tongue or gingivae. Multiple oral neuromas are a feature of the multiple endocrine neoplasia syndrome and as the oral signs may precede, the development of more serious aspects of the

presenting with multiple lesions should be referred to an endocrinologist.

### Malignant Tumours of the Oral Soft Tissues

- Epithelial tumours such as squamous cell carcinoma are rare in children. Malignant salivary neoplasms are also rare, although, mucoepidermoid carcinomas have been reported in young patients.
- Hodgkin's and non-Hodgkin's lymphomas have been reported in children; however, they are relatively rare in the paediatric age group. An exception is Burkitt's lymphoma which is endemic in parts of Africa, and occurs in those under 14 years of age; indeed in these areas, the condition accounts for almost half of all malignancy in children. Burkitt's lymphoma is multifocal, but a jaw tumour (more often in the maxilla) is often the presenting symptom. Burkitt's lymphoma is strongly linked to the *Epstein-Barr* virus as a causal agent.
- Rhabdomyosarcomas are malignant tumours of skeletal muscle, and present in patients around 9–12 years of age. The usual site is the tongue. Metastases are common, and the prognosis is poor.

### Jaw Cysts

- The dentigerous cyst is the most common jaw cyst in children. Its origin is the reduced enamel epithelium (early stage of tooth formation), and attachment to the tooth occurs at the amelocemental junction (where the enamel of the crown and the cementum of the root meet). There are often no symptoms, but eruption of the affected tooth will be prevented.
- Radicular cysts are related to the apex (root tip) of a non-vital tooth; they rarely occur in the primary dentition. They are often symptomless, and are discovered radiographically. Extraction, apicoectomy, or conventional endodontics will affect a cure.
- Lateral periodontal cysts are very rare in children.
- The odontogenic keratocyst (Fig. 23.34) is the most aggressive of the jaw cysts. It has a high rate of recurrence due to the fact that remnants left after incomplete removal will regenerate. These cysts may be found in children, and may be associated with the Gorlin-Goltz syndrome. Keratocysts associated with this syndrome appear in the first decade of life whereas the syndromic basal cell carcinomas are rare before puberty. Other signs and symptoms include: multiple basal cell carcinomas, bifid ribs, calcification of the falx cerebri, hypertelorism, and frontal and temporal bossing.
- Nonodontogenic cysts include the nasopalatine duct cyst, which may occur clinically as a swelling in the anterior midline of the hard palate and radiographically,



Fig. 23.34: Odontogenic keratocyst

as a radiolucency of greater than 6 mm diameter in the position of the nasopalatine duct. The anterior teeth commonly have vital pulps. Surgical excision is curative.

- The globulomaxillary cyst, which occurs between the upper lateral incisor and canine teeth, is now thought to be odontogenic in origin; either a radicular cyst, or an odontogenic keratocyst.
- The haemorrhagic bone cyst is a condition that may be found in children and adolescents. It occurs most commonly in the mandible in the premolar/molar region, and is often a chance radiographic finding and normally asymptomatic. Radiographically, it appears as a scalloped radiolucency between the roots of the teeth, and regresses either spontaneously or after surgical intervention.

#### Key Learning Points

- ➔ Mucoceles are the most common noninfective cause of salivary gland swelling in children.
- ➔ Orofacial granulomatosis may represent a local allergic reaction, or be a manifestation of an underlying systemic disease such as sarcoidosis or Crohn's disease.
- ➔ Aphthous ulceration in a child is usually of familial, immunological or microbial origin, and is not commonly associated with systemic disease.
- ➔ Malignant tumours of the oral soft tissues are rare, but do occur.
- ➔ The most common type of jaw cysts are those directly related to the teeth; dentigerous cysts form round the crowns of unerupted teeth, and radicular cysts form around the apex of nonvital teeth.

## INFECTION

### Viral Infections

#### *Herpes Simplex*

Initial infection with the herpes simplex virus type 1 (HSV-1) usually occurs in children between the ages of 6 months and 5 years. Younger infants are thought to be protected due to levels of circulating maternal antibodies. This initial infection is commonly known as acute herpetic gingivostomatitis.

Almost 100% of urban adult populations are carriers of the virus, which would suggest that the majority of childhood infections are subclinical. The virus is spread via droplet transmission, and has an incubation period of around 7 days.

Early symptoms include: Pyrexia, headache, general malaise, oral pain, mild dysphagia, and cervical lymphadenopathy. Later signs include: Severe oedematous marginal gingivitis (Fig. 23.35); fluid-filled vesicles on the gingivae, tongue, lips (Fig. 23.36), buccal, and palatal mucosa; and yellow ulceration with red inflamed margins (due to rupture of vesicles after a few hours).

Severe but very rare complications of the infection are encephalitis and aseptic meningitis.

The presentation of this infection is so characteristic that diagnosis is rarely a problem. Smears from newly ruptured vesicles can be taken if diagnosis is in doubt.

Herpetic gingivostomatitis does not respond well to active treatment. Hydration, bed rest, and a soft diet are recommended during the febrile stage. Pyrexia can be controlled using paracetamol or ibuprofen paediatric suspension. Secondary infection of ulcerated areas may be prevented by the use of chlorhexidine. Chlorhexidine mouthrinse (0.2%; two to three times a day) may be used in older children (> 6 years) who are able to expectorate but in younger children, a chlorhexidine spray can be used (twice daily), or the solution applied by the parent using a cotton swab. In severe cases where diagnosis has been made early, systemic acyclovir can be prescribed as a suspension (200 mg) and swallowed—five times daily for 5 days. In children under 2 years, the dose is halved. Acyclovir is active against the herpes virus but is unable to eradicate it completely.

Oral lesions heal without scarring, and the clinical signs and symptoms of the infection subside in around 14 days.

Following primary infection, the herpes virus remains dormant in the host's epithelial cells. The latent virus may become reactivated with this recurrent infection presenting as herpes labialis—the common “cold sore” (Fig. 23.37). This vesicular lesion presents on the mucocutaneous border of the lips and vesicles rupture to produce crusting. Intraoral recurrence is also possible presenting as an attenuated



**Fig. 23.35:** Gingivitis in acute herpetic gingivostomatitis



**Fig. 23.36:** Herpetic lesions in acute herpetic gingivostomatitis



**Fig. 23.37:** Recurrent herpes labialis

applying acyclovir cream (5%; five times daily for about 5 days); again, best results are with early treatment.

#### *Herpes Varicella-Zoster*

- Chickenpox is a presentation of varicella-zoster virus infection mainly affecting children. The virus produces



**Fig. 23.38:** Shingles

resemble those of primary herpetic infection. The condition is highly contagious but self-limiting.

- Shingles occurs as a reactivation of the latent virus within a skin dermatome (Fig. 23.38); it is far more common in adults. Orofacial presentation of the virus may lead to vesicular lesions within the peripheral distribution of a branch of the trigeminal nerve.

### Mumps

Mumps produces a painful enlargement of the parotid glands; it is usually bilateral. The causative agent is a myxovirus. Associated complaints include headache, vomiting and fever. Symptoms last for about a week, and the condition is contagious.

### Measles (*Rubeola*)

The intraoral manifestation of measles (Koplik's spots) occurs on the buccal mucosa as white speckling surrounded by a red margin. The oral signs usually precede the skin lesions, and disappear early in the course of the disease. The skin rash of measles normally appears as a red maculopapular lesion. Fever is present, and the disease is contagious.

### German Measles (*Rubella*)

German measles does not usually produce signs in the oral mucosa: however, the tonsils may be affected.

Protection against the diseases of mumps, measles and rubella can be achieved by vaccination of children in their early years.

### Herpangina

This is a coxsackie A virus infection that can be differentiated from primary herpetic infection by the different location of the vesicles. These are found in the tonsillar or pharyngeal region and in addition, herpangina lesions do not coalesce to form large areas of ulceration. The condition is short-lived.

### Hand, Foot and Mouth Disease

This coxsackie A virus infection produces a maculopapular rash on the hands and feet. Intraorally vesicles rupture to produce painful ulceration similar to aphthous ulcers. The condition lasts for 10–14 days.

### Infectious Mononucleosis

This condition, caused by the *Epstein-Barr* virus, is not uncommon amongst teenagers, and the usual form of transmission is by kissing. Oral ulceration and petechial haemorrhage at the hard/soft palate junction may occur. There is lymph node enlargement and associated fever. There is no specific treatment; however, it should be noted that the prescription of ampicillin and amoxycillin could cause a rash in those suffering from infectious mononucleosis and so, these antibiotics should be avoided during the course of the disease.

Treatment of all the above viral illnesses is symptomatic, and relies mainly on analgesia and maintenance of fluid intake. Aspirin should be avoided in children less than 12 years of age in order to avoid Reye's syndrome.

#### Key Learning Points

- ➔ Primary herpetic gingivostomatitis is the most common oral viral condition. Only when caught early, or when the patient is immunocompromised should antivirals be prescribed. This condition is likely to return throughout the patient's life as a common cold sore.
- ➔ Common childhood viral illnesses such as chickenpox and measles all have intraoral signs.

## BACTERIAL INFECTION

### Acute Orofacial Infection

Acute orofacial infection is usually the result of an untreated carious tooth, which has resulted in abscess formation with subsequent dissemination of infectious organisms into the surrounding tissues.

A rapidly spreading extraoral infection is a surgical emergency which merits immediate treatment, and may require admission for in-patient management (Fig. 23.39). Two areas of extraoral spread are of special importance.



**Fig. 23.39:** Acute orofacial infection

These are the submandibular region and the angle between the eye and nose. Swelling in the submandibular region arising from posterior mandibular teeth can produce raising of the floor of the mouth. This can cause a physical obstruction to breathing, and spread from this region to the parapharyngeal spaces may further obstruct the airway. The progression from dysphagia to dyspnoea can be rapid, and a submandibular swelling should be decompressed as a matter of urgency in children. A child with raising of the floor of the mouth requires immediate admission to hospital. The fact that trismus is invariably an associated feature makes expert anaesthetic help essential for safe management.

Infection involving the angle between eye and nose has the potential to spread intracranially, and produce a cavernous sinus thrombosis. This is a potentially life-threatening complication. The angular veins of the orbit have no valves, and connect the cavernous sinus to the external face. If the normal extracranial flow is obstructed due to pressure from the extraoral infection, then infected material can enter the sinus by reverse flow. To prevent this complication, infection in this area (which arise from upper anterior teeth, especially the canine) must be treated quickly.

The principles of the treatment of acute infection are:

- Remove the cause
- Institute drainage
- Prevent spread
- Restore function.

In addition, analgesia and adequate hydration must be maintained. Removal of the cause is essential to cure an orofacial infection arising from a dental source. This usually means extraction or endodontic therapy.

Institution of drainage and prevention of spread are supportive treatments—they are not definitive cures. Drainage may be obtained during the removal of the cause; for example, a dental extraction, or may precede definitive treatment if this makes management easier—for example, incision and drainage of a submandibular abscess.

Prevention of spread may be achieved surgically, or by the use of antibiotics. In severe cases, intravenous antibiotics will be used. The antibiotic of choice in children is penicillin.

It is important to remember that acute infections are painful and that, analgesics as well as antibiotics should be prescribed. The use of paracetamol elixir is usually sufficient. Similarly, it is important that a child suffering from an acute infection is adequately hydrated. If the infection has restricted the intake of oral fluids due to dysphagia, then admission to hospital for intravenous fluid replacement is required.

### *Staphylococcal Infections*

Impetigo may be caused by staphylococci and streptococci, and can affect the angles of the mouth and the lips.

It presents as a crusting vesiculobullous lesion. The vesicles coalesce to produce ulceration over a wide area. Pigmentation may occur during healing. The condition is self-limiting, although, antibiotics may be prescribed in some cases.

Staphylococcal organisms can cause osteomyelitis of the jawbone in children. Although the introduction of antibiotics has reduced the incidence of severe forms of the condition, it can still be devastating. In addition to aggressive antibiotic therapy, surgical intervention is required to remove bony sequestra.

### *Streptococcal Infection*

Streptococcal infections in childhood vary from a mucopurulent nasal discharge to tonsillitis, pharyngitis and gingivitis.

Scarlet fever is a beta-haemolytic streptococcal infection consisting of a skin rash with maculopapular lesions of the oral mucosa associated with tonsillitis and pharyngitis. The tongue shows characteristic changes from a strawberry appearance in the early stages to a raspberry-like form in the later stages.

### *Congenital Syphilis*

Congenital syphilis is caused by transmission from an infected mother. Oral mucosal changes such as rhagades, which is a pattern of scarring at the angle of the mouth, may occur. In addition, this disease may cause characteristic dental changes such as Hutchinson's incisors (the teeth taper towards the incisal edge rather than the cervical margin) and mulberry molars (globular masses of enamel over the occlusal surface).

## Tuberculosis

Tuberculous lesions of the oral cavity are rare; however, tuberculous lymphadenitis affecting submandibular and cervical lymph nodes is occasionally seen. These present as tender enlarged nodes that may progress to abscess formation with discharge through skin. Surgical removal of infected glands produces a much neater scar than that caused by spontaneous rupture through skin if the disease is allowed to progress.

## Cat-Scratch Disease

This is a self-limiting disease, which presents as an enlargement of regional lymph nodes. It is caused by rickettsiae like agent (*Rochalimaea quintana*). After successful cultivation, the new species has been named *R. henselae*. The nodes are painful, and enlargement occurs up to 3 weeks following a cat-scratch. The nodes become suppurative, and may perforate the skin. Treatment often involves incision and drainage.

### Key Learning Points

- ➔ The principles of treatment of acute infection: Remove the cause; institute drainage; prevent spread, and restore function.
- ➔ Impetigo may be caused by staphylococci and streptococci, and can affect the angles of the mouth and lips.
- ➔ Streptococcal infection in children may cause nasal discharge, tonsillitis, pharyngitis and gingivitis.

## Fungal Infection

### Candidiasis

Neonatal acute candidiasis (thrush) contracted during birth is not uncommon. Likewise, young children may develop the condition when resistance is lowered, or after antibiotic therapy. The white patches of *Candida* are easily removed to leave an erythematous (Fig. 23.40) or bleeding base. Treatment with nystatin or miconazole is effective [those under 2 years of age should receive 2.5 ml of a miconazole gel (25 mg/ml) twice daily; 5 ml twice daily is prescribed for those under 6 years of age, and 5 ml four times a day for those over 6 years of age].

### Actinomycosis

Actinomycosis can occur in children, and may follow intraoral trauma including dental extractions. The organisms spread through the tissues, and can cause dysphagia if the submandibular region is involved. Abscesses may rupture onto the skin, and long-term antibiotic therapy is required. Penicillin should be prescribed and maintained for at least 2 weeks following clinical cure.



Fig. 23.40: Candidal infection

## Protozoal Infections

Infection by *Toxoplasma gondii* may occasionally occur in children; the principle reservoir of infection being cats. Glandular toxoplasmosis is similar in presentation to infectious mononucleosis, and is found mainly in children and young adults. There may be a granulomatous reaction in the oral mucosa, and there can be parotid gland enlargement. The disease is self-limiting, although, in severe infection, an anti-protozoal such as pyrimethamine may be used.

### Key Learning Points

- ➔ Neonatal candidiasis can be contracted in the birth canal.
- ➔ Candidal infections can occur in children following antibiotic therapy.

## ANOMALIES

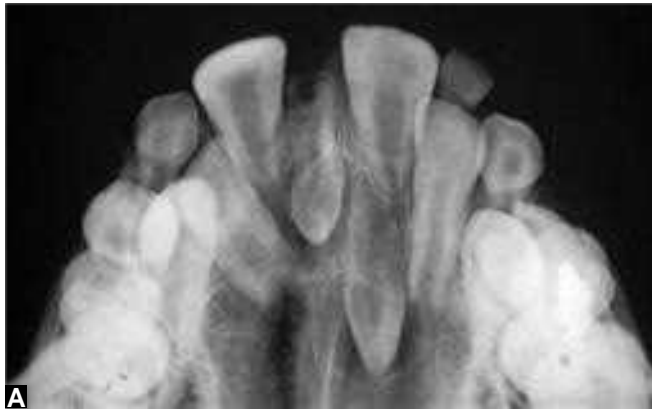
### Anomalies in Number of Teeth

Alterations in tooth number result from problems during dental development. In addition to hereditary patterns producing extra or missing teeth, local aetiological factors can also affect tooth number.

### Hyperdontia

Hyperdontia (supernumerary teeth) occurs in both primary and permanent dentition; its incidence in the permanent dentition is around 1–3%, and affects male twice as often as females. The most common position for an extra tooth is the maxillary midline (Figs 23.41A and B). Several syndromes are associated with hyperdontia, and the following conditions all require referral to a dental surgeon.

- Cleidocranial dysostosis
- Gardner syndrome
- Crouzon's syndrome (Craniofacial dysostosis).



**Figs 23.41A and B:** (A) Radiograph showing unerupted supernumerary teeth; (B) Clinical picture showing erupted supernumerary teeth



**Fig. 23.42:** Congenitally absent teeth

### Hypodontia

Hypodontia is the term given to the congenital absence of teeth (Fig. 23.42). It is most commonly hereditary, and affects between 3–6% of the population (excluding third molars). The mandibular second premolar is the most commonly missing tooth. Syndromes associated with hypodontia include: ectodermal dysplasia, achondroplasia, and rieger syndrome.

## Anomalies in Size of Teeth

### Microdontia

Three types of microdontia (small teeth) are recognised:

1. True generalized microdontia—all teeth are normally formed, but smaller than normal; occurs in pituitary dwarfism.
2. Relative generalized microdontia—normal or slightly smaller teeth present in jaws that are larger than normal.
3. Microdontia—usually, only one tooth is involved; affects maxillary lateral incisors and third molars; may occur

Conditions associated with microdontia include down syndrome, ectodermal dysplasia, and Ellis-van Creveld syndrome.

### Macrodontia

Macrodontia (large teeth) can also be classified as three types:

1. True generalized macrodontia—several teeth are larger than normal; seen in pituitary gigantism.
2. Relative generalized macrodontia—teeth are normal, or slightly larger than normal in small jaws.
3. Macrodontia of a single tooth is relatively uncommon. An isolated tooth displaying macrodontia can result from twinning abnormalities that originate during the proliferation phase of development. Fusion and gemination are the most common twinning abnormalities, and both demonstrate enlarged crowns.

### Double Teeth

Fusion is said to occur when there has been union of two embryonically developing teeth, and occurs more commonly in the primary dentition. The majority of these teeth have large bifid crowns with one pulp chamber. Gemination is said to occur when there has been incomplete division of a single tooth bud and again, occur more commonly in the primary dentition. Again, the appearance is of a large bifid crown with one pulp chamber. As it is difficult to distinguish clinically between these two entities, fusion and germination, the favoured term of “double teeth” (Fig. 23.43) has now more commonly been adopted.

## Anomalies in Tooth Shape

Abnormalities of shape originate during the morpho-differentiation stage of teeth development, and are manifested



**Fig. 23.43:** Double lateral incisor



**Fig. 23.44:** Radiograph showing dens invaginatus

### *Dens Evaginatus*

Dens evaginatus (extra cusp) occurs due to an evagination of enamel. It occurs most commonly in the central groove of posterior teeth, or on the cingulum of anterior teeth; this is sometimes known as a Talon cusp. The extra cusp contains enamel, dentine and pulp tissue.

### *Dens in Dente/Dens Invaginatus*

Dens in dente/dens invaginatus (Fig. 23.44) occurs due to an invagination of enamel, and usually affects the maxillary lateral incisor tooth. Enamel and dentine can be missing in the invaginated area leading to pulpal exposure.

### *Taurodontism*

Taurodontism occurs when there has been an abnormality

Teeth appear to have elongated pulp chambers and short blunt roots. This condition may be associated with a number of syndromes: Klinefelter syndrome; tricho-dento-osseous syndrome; orofacioidigital syndrome II; hypohidrotic ectodermal dysplasia; amelogenesis imperfecta-type IV, and Down syndrome.

Tooth dilaceration is seen in 25% of permanent teeth commonly following an intrusion injury to the primary dentition. These teeth have an abnormal bend in the crown or root. Children with congenital ichthyosis may show this phenomenon.

## **Anomalies in Enamel and Dentine**

### *Amelogenesis Imperfecta*

Amelogenesis imperfecta (AI) is a group of hereditary defects of enamel, which are unassociated with any other medical condition. Amelogenesis is an entirely ectodermal disturbance with an incidence of 1 in 14,000. Both primary and permanent dentitions are affected, and the condition can be classified into four major categories.

#### **Type I: Hypoplastic AI**

This defect occurs during the histodifferentiation stage. Enamel is not formed to full thickness because ameloblasts fail to lay down sufficient matrix. The resulting disorder may include a localized defect, localized pitting, or generalized lack of enamel formation. Affected teeth appear small with open contacts due to very thin or nonexistent enamel causing thermal sensitivity.

#### **Type II: Hypomaturation AI**

This defect occurs during matrix apposition. Enamel is softer, and chips from the underlying dentine (Fig. 23.45). Enamel has a mottled brown-yellow-white colour. Interproximal contact points between teeth are present as enamel is of normal thickness. Radiographically, enamel approaches the radiodensity of dentine.

#### **Type III: Hypocalcified AI**

Defect occurs during the calcification stage; most common type of amelogenesis imperfecta. Enamel is of normal thickness but soft, friable, and easily lost by attrition. Enamel appears dull, lustrous, honey coloured, and stains easily.

#### **Type IV: Hypomaturation-hypoplastic with taurodontism**

Defects occur during both the apposition and histodifferentiation stages; most rare type of enamel defect. Features include patchy areas of reduced enamel thickness leading to loss of interproximal contacts, taurodontism and severe attrition. Radiographically, the radiodensity of enamel





**Fig. 23.45:** Hypomaturation form of amelogenesis imperfecta



**Fig. 23.47:** Chronological banding seen in tetracycline staining



**Fig. 23.46:** Fluorosis



**Fig. 23.48:** Localised enamel hypoplasia

### *Environmental Enamel Hypoplasia or Hypomineralisation*

These are defects in the quantitative or qualitative characteristics of the enamel, which can be caused by various systemic factors present during the period of enamel formation such as:

- Nutritional deficiencies in vitamin A, C, D, calcium and phosphorus
- Severe infections such as rubella, syphilis, and high fever
- Neurologic defects such as cerebral palsy and Sturge-Weber syndrome
- Prematurity and birth injuries
- Radiation
- Fluorosis—excessive ingestion of fluoride (Fig. 23.46)
- Tetracycline induced hypoplasia and discolouration (Fig. 23.47)
- Increasing incidence.

All teeth forming during these periods of environmental

### *Localised Enamel Hypoplasia (Turner's Teeth)*

Infection of individual primary teeth may affect the developing permanent tooth leading to localised patches of hypoplasia/hypomineralisation (Fig. 23.48). This effect can also result following trauma to primary tooth, which disturbs the permanent tooth bud.

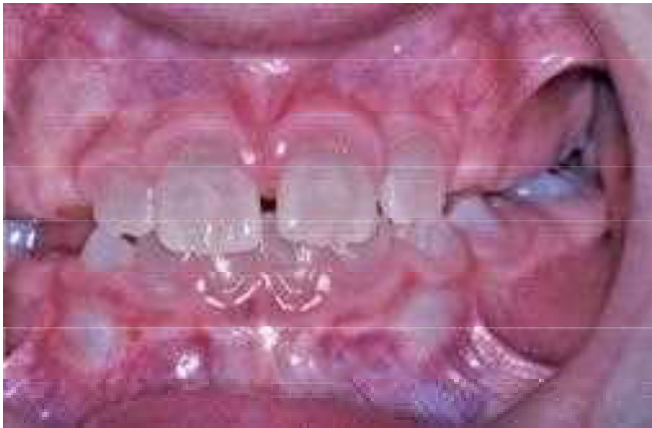
### *Dentinogenesis Imperfecta*

Dentinogenesis imperfecta (DI) are a group of inherited dentine defects originating during the histodifferentiation stage of dentine formation. The condition affects 1 in 8000, and can be subdivided into three basic types:

- Shields type I (associated with osteogenesis imperfecta)—inherited defect in collagen formation resulting in osteoporotic brittle bones; these patients commonly have blue sclera (Fig. 23.49). Primary teeth more affected than permanent teeth. Other features include periapical radiolucencies, bulbous crowns, obliteration of pulp chambers, root fractures, and amber translucent tooth



**Fig. 23.49:** Blue sclera seen in osteogenesis imperfecta



**Fig. 23.50:** Dentinogenesis imperfecta

- Shields type II (hereditary opalescent dentine)—primary and permanent dentitions are equally affected. Features are same as shields type I except there is no osteogenesis imperfecta.
- Shields type III (brandywine type)—teeth have a shell-like appearance with bell-shaped crowns; occurs exclusively in an isolated group in Maryland, USA called the brandywine population.

### Dentine Dysplasia

These are inherited dentine defects involving circumpulpal and root morphology; classified into two types:

- Shields type I—both primary and permanent teeth exhibit normal crown morphology, multiple periapical radiolucencies, short roots, and absent pulp chambers.
- Shields type II—amber coloured primary teeth. Permanent teeth are normal in appearance, but radiographically demonstrate thistle-tube shaped pulp chambers.

### Odontodysplasia (Ghost Teeth)

These teeth show a localized arrest in tooth development

have a “ghost-like” appearance with short roots, shell-like crowns, and large diffusely calcified pulp chambers.

### Anomalies in Cementum

Developmental defects involving cementum are uncommon.

#### *Hypophosphatasia*

This is a rare cause of premature mobility of the teeth. Other features are: low serum alkaline phosphatase levels; osteoporosis with bone fragility, and failure of cementum formation leading to premature loss of primary incisors.

#### Key Learning Points

- ➔ Anomalies of enamel and dentine can be very painful as well as unsightly, and these children should be seen by a specialist in paediatric dentistry.
- ➔ Type I dentinogenesis imperfecta is associated with osteogenesis imperfecta.

## DENTOALVEOLAR TRAUMA

### Prevalence and Aetiology

Dental trauma in childhood and adolescence is common. At 5 years of age, 31–40% of boys and 16–30% of girls will have suffered some dental trauma; so will have 12–33% of boys and 4–19% of girls at 12 years of age. Boys are affected almost twice as often as girls in both the primary and the permanent dentitions.

The majority of dental injuries in the primary and permanent dentitions involve the anterior teeth, especially the maxillary central incisors. The mandibular central incisors and maxillary lateral incisors are less frequently involved.

The most accident-prone times are between 2 years and 4 years for the primary dentition, and 7 years and 10 years for the permanent dentition. In the primary dentition, coordination and judgement are incompletely developed, and the majority of injuries are due to falls in and around the home as the child becomes more adventurous and explores its surroundings. In the permanent dentition, most injuries are caused by falls and collisions while playing and running, although, bicycles are a common accessory. The place of injury varies in different countries according to local customs, but accidents at school remain common.

Sports injuries usually occur in teenage years, and are commonly associated with contact sports such as soccer, rugby, ice hockey, and basketball.

Injuries due to road traffic accidents and assaults are most commonly associated with the late teenage years and adulthood, and are often closely related to alcohol abuse.

One form of injury in childhood that must never be forgotten is child physical abuse or non-accident injury. It

Patients with protrusion of upper incisors and insufficient lip closure are at significantly greater risk of traumatic dental injuries.

### Dental History

- When did injury occur? The time interval between injury and treatment significantly influences the prognosis of avulsions, luxations, crown fractures with or without pulpal exposures, and dentoalveolar fractures.
- Where did injury occur? May indicate the need for tetanus prophylaxis.
- How did injury occur? The nature of the accident can yield information on the type of injury expected. Discrepancy between history and clinical findings raises suspicion of nonaccidental injury.
- Lost teeth/fragments? If a tooth or fractured piece cannot be accounted for when there has been a history of loss of consciousness, then a chest radiograph should be obtained to exclude inhalation.
- Previous dental history? Previous trauma can affect future prognosis. An idea of previous dental treatment carried out will help decide on what treatment is possible.

### Intraoral Examination

This must be systematic, and include the recording of:

- Laceration, haemorrhage, and swelling of the oral mucosa and gingiva. Any lacerations should be examined for tooth fragments, or other foreign material. Lacerations of lips or tongue require suturing but those of the oral mucosa heal very quickly, and may not need suturing. Orofacial signs of nonaccidental injury (NAI) may present in this manner.
- Abnormalities of occlusion, tooth displacement, fractured crowns or cracks in the enamel.

The following signs and reactions to tests are particularly helpful:

- *Mobility*: Degree of mobility is estimated in a horizontal and a vertical direction. When several teeth move together, a fracture of the alveolar process is suspected. Excessive mobility may also suggest root fracture or tooth displacement.
- *Reaction to percussion*: In a horizontal and vertical direction, and compared against a contralateral uninjured tooth. A duller note may indicate root fracture.
- *Colour of tooth*: Early colour change is visible on the palatal surface of the gingival third of the crown.

### Injuries to the Primary Dentition

During its early development, the permanent incisor is located palatally to and in close proximity with the apex of



**Fig. 23.51:** Avulsion injury to upper right primary central incisor

is risk of damage to the underlying permanent incisor (Fig. 23.51).

Due to the patient's age, few restorative procedures will be possible and in the majority of cases, the decision is between extraction and maintenance without performing extensive treatment. A primary incisor should always be removed if its maintenance will jeopardize the developing tooth bud.

### Injuries to the Permanent Dentition

Most traumatized teeth can be treated successfully. Prompt and appropriate treatment improves prognosis.

#### Emergency Treatment

- Retain vitality of fractured or displaced tooth
- Treat exposed pulp tissue
- Reduction and immobilization of displaced teeth
- Antiseptic mouthwash, antibiotics, and tetanus prophylaxis
- Advise soft diet.

#### Injuries to the Hard Dental Tissues and the Pulp

*Enamel-dentine fracture*: Immediate treatment is necessary due to the involvement of dentine (Fig. 23.52). The pulp requires protection against thermal irritation and from bacteria via the dentinal tubules. Restoration of crown morphology also stabilizes the position of the tooth in the arch. Emergency protection of the exposed dentine should be carried out as soon as possible; refer to a dental surgeon.

*Enamel, dentine, pulp fracture*: Immediate treatment is required which will involve treatment of the pulpal tissue; refer to a dental surgeon (Fig. 23.53).

*Root fracture*: Root fractures occur most frequently in the middle or the apical third of the root (Fig. 23.54). The coronal fragment may be extruded or luxated. Luxation is



Fig. 23.52: Enamel dentine fractures of permanent incisors



Fig. 23.53: Enamel, dentine and pulp fracture

If displacement has occurred, the coronal fragment should be repositioned as soon as possible by gentle digital manipulation, and referred as soon as possible to a dental surgeon.

### Splinting

Trauma may loosen a tooth either by damaging the periodontal ligament or fracturing the root. Splinting immobilizes the tooth in the correct anatomical position so that further trauma is prevented, and healing can occur. Different injuries require different splinting regimens. A functional splint involves one, and a rigid splint two; abutment teeth either side of the injured tooth. There are a number of types and methods of splinting; the most effective of which require materials generally only held in a dental surgery.

### Injuries to the Periodontal Tissues

**Subluxation:** In addition to the above, there is rupture of



Fig. 23.54: Radiograph showing root fractures

the socket, although, not displaced. All these injuries should be referred to a dental surgeon. The treatment for both these injuries is:

- Occlusal relief
- Soft diet for 7 days
- Immobilization with a splint if tenderness to percussion is significant
- Chlorhexidine 0.2% mouthwash; twice daily.

There is minimal risk of pulpal necrosis following this injury, and in over 97% of cases, there is no evidence of resorption.

**Extrusive luxation:** There is a rupture of periodontal ligament and pulp (Fig. 23.55).

**Lateral luxation:** There is a rupture of the periodontal ligament, pulp, and the alveolar plate. Refer patient to a dental surgeon as soon as possible. You may wish to prescribe chlorhexidine mouthwash and amoxicillin, and advise a soft diet.

Antibiotics may have a beneficial effect in promoting repair of the periodontal ligament. They do not appear to affect pulpal prognosis.

**Intrusive luxation:** These injuries are the result of an axial, apical impact, and there is extensive damage to the periodontal ligament, pulp and alveolar plate (Fig. 23.56).

**Avulsion and replantation:** Avulsion is when a tooth has been completely removed from its socket (Fig. 23.57). Replantation (Fig. 23.58) should nearly always be attempted, even though it may offer only a temporary solution due to the frequent occurrence of external inflammatory resorption. Even when resorption occurs, the tooth may be retained for



**Fig. 23.55:** Extrusive and lateral luxation injury



**Fig. 23.58:** Replanted avulsed teeth ready for splinting



**Fig. 23.56:** Radiograph showing intrusive luxation injury



**Fig. 23.57:** Avulsion injury

the height and width of the alveolus to facilitate later implant placement.

Successful healing after replantation can only occur if there is minimal damage to the pulp and the periodontal ligament. The type of extra-alveolar storage medium and the extra-alveolar time, i.e. the time the tooth has been out of the mouth, are critical factors. The suggested protocol for replantation can be divided into: advice on phone; immediate treatment in surgery, and review.

#### **Advice on phone (to teacher, parent, etc.):**

- Do not touch root. Hold by crown.
- Wash gently under cold tap water for a maximum of 10 seconds
- Replace into socket or transport in milk to surgery
- If replaced, bite gently on a handkerchief to retain it, and come to surgery.

The best transport medium is the tooth's own socket. Understandably, non-dentists may be unhappy to replant the tooth, but milk is an effective iso-osmolar medium. Saliva, the patient's buccal sulcus, or normal saline are alternatives.

#### **Immediate surgery treatment:**

- Do not handle root. If replanted, remove tooth from socket
- Rinse tooth with normal saline. Note state of root development. Store in saline
- Local analgesia
- Irrigate socket with saline, and remove clot and any foreign material
- Push tooth gently, but firmly into socket
- Non-rigid functional splint for 7–10 days
- Check occlusion
- Baseline radiographs: Periapical or anterior occlusal. Any other teeth injured?
- Antibiotics, chlorhexidine mouthwash, soft diet as previously
- Check tetanus immunisation status.

For adequate splinting, the patient will need urgent referral to a dental surgeon. If dental services are unavailable, the tooth can be held in place with some moulded cooking foil (Fig. 23.59), or sutured into position; this will ensure safety from dislodgement, or inhalation until dental treatment is obtained.



**Fig. 23.59:** Foil splint



**Fig. 23.60:** Alveolar bone fracture

### *Injuries to the Supporting Bone*

The extent and position of the alveolar fracture should be verified clinically and radiographically (Fig. 23.60). If there is displacement of the teeth to the extent that their apices have risen up and are now positioned over the labial or lingual/palatal alveolar plates (apical lock), then they will require extruding first to free the apices prior to repositioning.

The segment of alveolus with teeth requires only 3–4 weeks of ridged splinting with two abutment teeth either side of the fracture; together with antibiotics, chlorhexidine, soft diet, and tetanus prophylaxis check.

Pulpal survival is more likely if repositioning occurs within 1 hour of the injury. Root resorption is rare.

### **Child Physical Abuse (Nonaccidental Injury)**

A child is considered to be abused if he or she is treated in a way that is unacceptable in a given culture at a given time (Fig. 23.61). Child physical abuse is now recognised as an international issue, and has been reported in many countries. Each week, at least 1–2 children in Britain and 80 children in the United States will die as a result of abuse or neglect. At least one child per 1000 in Britain suffers severe physical



**Fig. 23.61:** Slap mark on face of physically abused child

internal injuries or mutilation and in the United States, more than 95% of serious intracranial injuries during the first year of life are the result of abuse. Although some reports will prove to be unfounded, the common experience is that proved cases of child abuse are four to five times as common as they were a decade ago.

Child abuse is not a full diagnosis; it is merely a symptom of disordered parenting. The aim of intervention is to diagnose and cure the disordered parenting. Simply to aim at preventing death is a lowly ambition. It has been estimated in the United States that 35–50% of severely abused children will receive serious re-injury, and 50% will die if they are returned to their home environment without intervention. In some cases, the occurrence of physical abuse may provide an opportunity for intervention. If this opportunity is missed, there may be no further opportunity for many years.

Approximately, 50% of cases diagnosed as child physical abuse have extra- and intraoral facial trauma and so, the dental practitioner may be the first professional to see or suspect abuse. Injuries may take the form of contusions and ecchymoses, abrasions and lacerations, burns, bites, dental trauma, and fractures.

The following 10 points should be considered whenever doubts and suspicions are aroused.

1. Could the injury have been caused accidentally and if so, how?
2. Does the explanation for the injury fit the age and the clinical findings?
3. If the explanation of cause is consistent with the injury, is this itself within normally acceptable limits of behaviour?
4. If there has been any delay seeking advice, are there good reasons for this?
5. Does the story of the accident vary?

7. The child's reaction to other people, and to any medical/dental examinations.
8. The general demeanour of the child.
9. Any comments made by child and/or parent that give concern about the child's upbringing or lifestyle.
10. History of previous injury.

#### Key Learning Points

- ➔ Following dental, quickly assess whether the patient has more pressing injuries elsewhere. If not, expedient dental treatment is required especially if a permanent tooth has been avulsed.
- ➔ If a permanent tooth has been avulsed, it should be placed back in the socket as soon as possible; if this is not possible, place it in cold fresh milk handling only by the crown.
- ➔ When dealing with dental trauma, always consider the possibility of nonaccidental injury.

## ORAL MANIFESTATIONS OF SYSTEMIC DISEASE

In addition to specific pathological oral conditions, diseases that affect other systems of the body can present oral manifestations; for example, Crohn's disease. Disorders such as chronic renal failure and diabetes can predispose to periodontal disease, and there may be poor resistance to spread of odontogenic infection.

The temporomandibular joint can be involved in juvenile idiopathic arthritis, and the jaws can be affected in hyperparathyroidism (giant cell tumours).

Not only can the oral soft tissues be affected by systemic conditions, but the physician should also be alert about the fact that the oral mucosa may exhibit signs that help to diagnose a systemic condition.

# Immunity and Allergy

In order to grow and develop normally, we have to develop methods of protecting ourselves from organisms which have the potential for invasion and to cause damage. Pathogenesis of infectious disease is not only dependent upon characteristics of the pathogen, but also upon our immune response to it. As children develop from foetal life through infancy into childhood, so their immune systems are continuing to mature. Hence susceptibility to different infectious agents varies with age.

## COMPONENTS OF THE IMMUNE SYSTEM

The first line of defence against infection is the physical barrier formed by the skin and mucous membranes.

### The Skin

The epidermis is made up of four layers of densely packed cells, through which bacteria cannot penetrate. The outer layers are shed, taking organisms with them. Its dryness, together with the high salt content due to sweat, and low pH due to sebum and lactobacilli inhibits bacterial growth. Sweat also contains lysozyme, which is an antimicrobial enzyme particularly for gram-positive organisms. Sebum from hair follicles contains lipids, salts and proteins which have antimicrobial properties, but it also provides nutrition for commensal organisms such as corynebacteria. Skin cells can also secrete antimicrobial peptides such as cathelicidins, defensins and dermcidins. These peptides do not only have a direct effect, but they also stimulate components of the innate and adaptive immune system. Organisms which are able to colonise the skin surface inhibit pathogens, and many secrete proteins toxic to other species, known as bacteriocins.

Cells of the innate immune systems (Langerhans' cells, mast cells) and adaptive immune system (lymphocytes) are also found in the dermis should the superficial epidermis be penetrated.

### Mucous Membranes

These are body surfaces not covered by skin. They are therefore protected by viscous mucus which traps micro-organisms, and by washing. For example, tears wash organisms from the conjunctiva, and saliva and chewing of food has the same function in the mouth.

### The Respiratory Tract

The nasal turbinates are designed to trap large particles, preventing their travelling down the respiratory tract. Smaller particles get further down, but cough and irritant receptors stimulate cough and bronchoconstriction, enabling them to be cleared. The mucociliary blanket is the chief means of clearing the respiratory tract from the smallest bronchioles to the larynx. In addition, compounds secreted onto the surface of the respiratory epithelium enhance bacterial killing. These include lysozyme, transferrin, alpha 1 antitrypsin, opsonins, interferon, as well as immunoglobulins and complement.

### The Gastrointestinal Tract

In contrast to the respiratory tract, where potential pathogens are swept proximally, in the gut, peristalsis keeps bacteria moving distally to be eliminated. Gastric acid creates a stomach pH which is toxic to many bacteria, and those surviving to pass into the small intestine encounter bile and pancreatic secretions. The gut is not a sterile environment, and the normal gut flora is important in keeping pathogenic bacteria at bay. The intestinal wall is protected from invasion by these organisms by intestinal mucins which bind potential pathogens. Molecules such as lysozyme and immunoglobulins are secreted onto the epithelial surface. The epithelial cells themselves are joined by tight junctions, which limit the passage of antigens across the barrier.



### Urogenital Tract

The flow of urine washes micro-organisms away from the mucosal surface. Vaginal mucus performs the same function. In addition, the vesicoureteric junction acts as a one way valve, preventing urine (and micro-organisms) flowing towards the kidneys.

### THE NEXT LINE OF DEFENCE: INNATE (NON-SPECIFIC) IMMUNITY

Both humoral (chemical) agents and cells play major roles.

#### Humoral Agents

These agents are as follows:

##### Acute Phase Proteins

These are proteins produced by the liver whose plasma levels rise in response to inflammation.

- *C-reactive protein* assists complement in binding to foreign or damaged cells
- *Mannose binding lectin* binds to carbohydrate moieties on the surface of bacteria and fungi, thus activating the lectin pathway of the complement system

- *Alpha 1 antitrypsin* and *alpha 2 macroglobulin* inhibit the activity of harmful proteases produced by bacteria
- *Ferritin* binds iron which is necessary for bacterial growth
- Others include coagulation factors (fibrinogen, plasminogen, factor VIII, von Willebrand factor), components of complement, amyloid P and amyloid A

#### Antibacterial Agents

These include lysozyme, defensins, lactoferrin and myeloperoxidase.

#### Complement

This is a series of blood proteins which, when activated, lead to lysis of bacteria, and also stimulate chemotaxis and phagocytosis.

The *classical pathway* is activated by bacterial antigen bound to antibody. The *alternative pathway* is activated directly by bacterial or fungal oligosaccharide, endotoxin and immunoglobulin aggregates. The *lectin pathway* is activated by Mannan binding lectin bound to its receptor on the bacterial surface (Fig. 24.1).

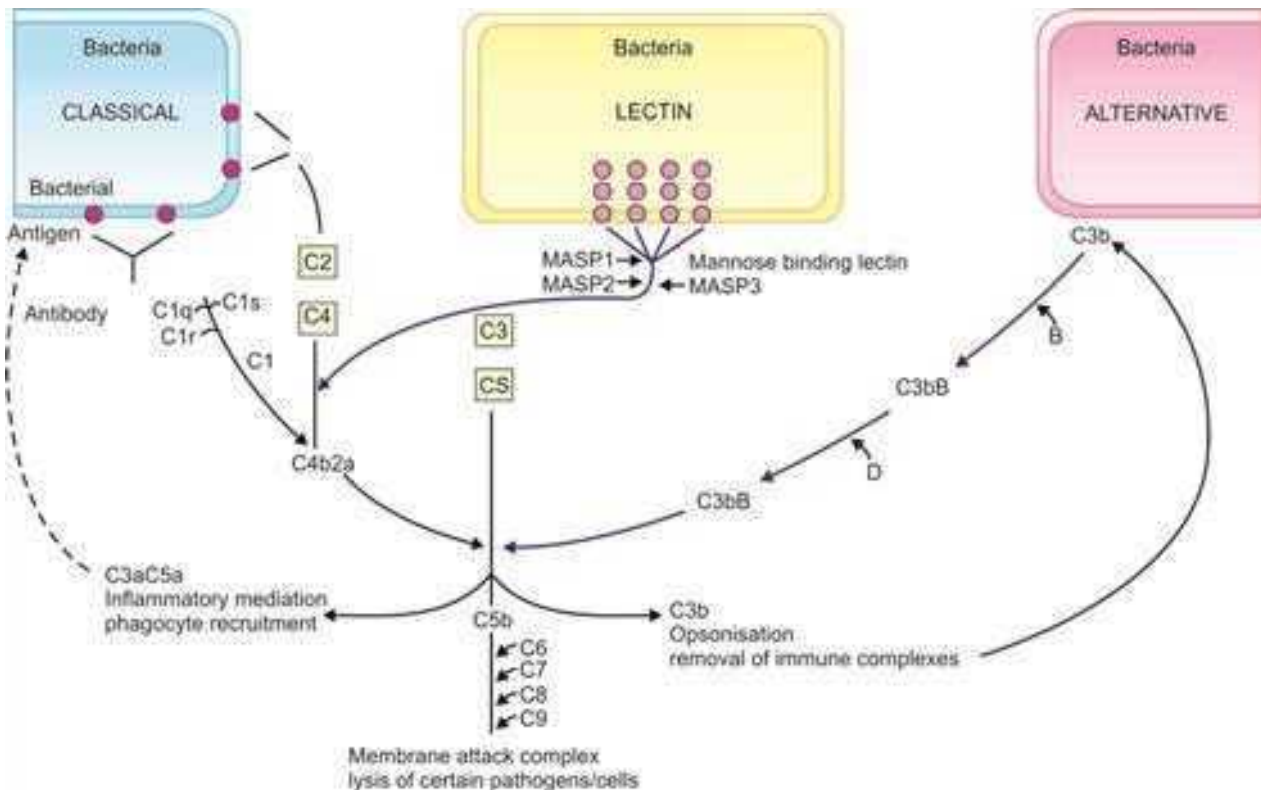


Fig. 24.1: Complement cascade—classical, all ± lectin pathways

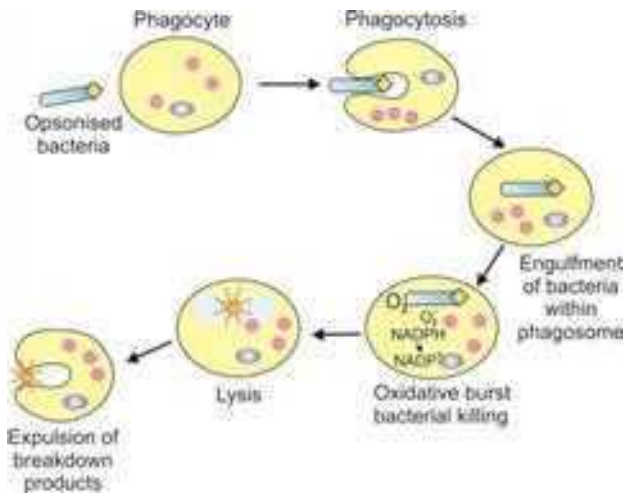


Fig. 24.2: Phagocytosis with oxidative burst

## CELLS OF INNATE IMMUNE SYSTEM

### Phagocytes

These include monocytes/macrophages and neutrophils. They engulf opsonised bacteria and kill them within the phagosome. The most important mechanism for bacterial killing is the oxidative burst, illustrated in the Figure 24.2. The oxygen radicals, hydrogen peroxide and hydroxyl ions all mediate killing.

### Eosinophils

These comprise 1–3% of circulating white blood cells. They are less efficient at phagocytosis and bacterial killing than neutrophils. They can kill parasites opsonised by antibody or complement. Eosinophil granule protein contains some powerful inflammatory mediators which can kill helminths directly, and induce basophil histamine release. It has long been assumed that they have a major role in defence against parasites, but their true function is unclear. When activated during an allergic response, these mediators cause tissue damage, particularly to the respiratory epithelium, causing chronic inflammatory change.

### Basophils

These cells develop from promyelocytes in the bone marrow. They have granules containing many of the same mediators of immediate hypersensitivity as mast cells, but do not release heparin or arachidonic acid metabolites. They are found in the circulation. Again, it is assumed that they have some role in defence against parasitic disease.

### Mast Cells

These cells develop from pluripotential stem cells (CD34+ cells) which migrate into tissues, and mature into mast cells which are

differentiated from each other, depending on their site. They are activated in allergy, but can also be activated by pathogens or their products, peptide mediators such as substance P, endothelin, and components of complement. They have high affinity for IgE and release chemicals such as histamine, neutrophil chemotactic factor, inflammatory proteases and heparin, which are pre-formed inflammatory mediators contained in granules. When stimulated they also produce arachidonic acid metabolites and platelet activating factor.

### Natural Killer Cells

These are large lymphocytes which recognise and kill cells infected with viruses or intracellular pathogens such as *Listeria* and *Toxoplasma*. They also recognise tumour cells. They recognise these cells either because of reduced expression of class I HLA molecules on their surface, or by binding to CD16 receptor on an antibody coated target cell (antibody dependent cellular cytotoxicity). They release granules which increase the permeability of the target cell (perforin) and cytokines which promote apoptosis.

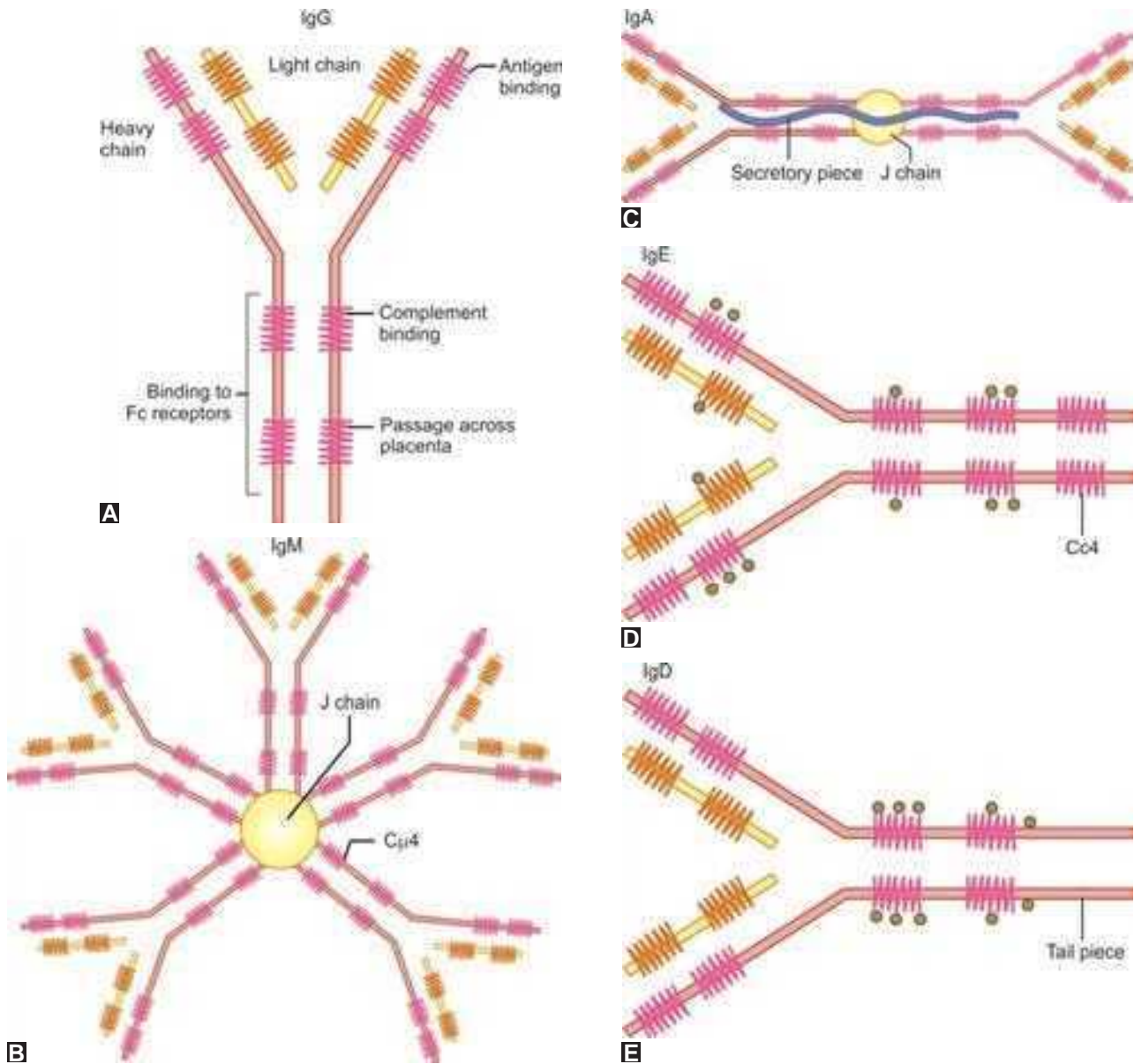
## THE ADAPTIVE (ACQUIRED) IMMUNE SYSTEM

### Humoral Agents: Immunoglobulins

These are proteins which mediate antibody responses, and are found in blood, tissues, secretions and also as part of the surface membrane of B cells. They combine with antigen to form immune complexes, and can opsonise bacteria, fix complement and neutralise viruses.

Figures 24.3A to E show the basic structure of immunoglobulin. Each molecule consists of two heavy chains and two light chains, joined by disulphide bridges. The characteristics of the 5 classes are shown:

- *IgG* activates complement via the classical pathway, opsonises organisms and mediates antibody dependent cytotoxic responses
- *IgM* is important for clearing bacteria from the blood stream by agglutination and opsonisation. It is the most efficient fixer of complement by the classical pathway
- *IgA* in its secretory form is important for antiviral and antibacterial activity on mucosal surfaces. It can fix complement via the alternate pathway, and has bactericidal activity when combined with lysozyme and complement
- *IgD*: The majority of IgD is bound to B cell membranes, where it acts as an antigen receptor, and is important in the development of B cell responses
- *IgE* triggers immediate hypersensitivity. This may be important in defence against worm infection, by binding to the worm, and stimulating mast cell degranulation, leading to the worm being flushed from the mucosal surface.



Figs 24.3A to E: Basic structure of immunoglobulin and classes

### Cells of Adaptive Immune System

#### T Cells

These are the co-ordinators and regulators of specific immunity. They interact with cells of the innate immune system (antigen presenting cells) and with B cells, and produce cytokines which stimulate or suppress the activity of other inflammatory cells.

#### Antigen Presentation and T Cells

In the process of phagocytosis and elimination of organisms within the phagosome, not all foreign protein is destroyed.

A small portion is preserved and then presented on the surface of the cell associated with molecules of the major histocompatibility complex (MHC). The T cell receptor binds to this complex, and is activated, as illustrated in Figure 24.4. Macrophages function both as phagocytes and antigen presenting cells, whereas the major role of dendritic cells is to capture antigen for presentation. Other cells, such as B cells and virus infected cells, can also present antigen + MHC.

T cells are classified according to their surface markers and function.

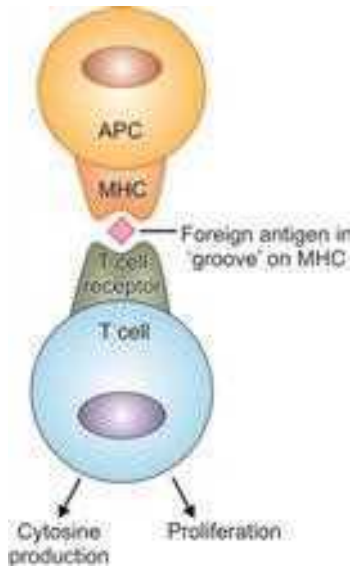


Fig. 24.4: Antigen presentation

### T Helper Cells

These have the CD4 marker. They recognise antigen associated with class II MHC.

- *Th1 cells* differentiate under the influence of interferon gamma and IL12. Activation leads to release of IL2, interferon gamma and tumour necrosis factor (TNF). These stimulate cytotoxic T cells and cell mediated immune responses, including delayed hypersensitivity
- *Th2 cells* are the main co-ordinators of B cell responses. They possess CD40 ligand which binds to CD40 on the immature B cell surface. This lead to B cell isotype switching and production of B cell memory cells. The main cytokine involved is IL4. Activation of Th2 also leads to stimulation of IgE production, and so mediates immediate hypersensitivity
- *Th0 cells* initially produce both Th1 and Th2 cytokines. However, either response may predominate, depending on genetic predisposition, type of antigen exposure, and influence of co-stimulatory molecules

### Cytotoxic T Cells

These are characterised by the CD8 marker, which binds to MHC class I. They are responsible for killing virus infected cells.

### The Thymus and T Cell Immunity

Early in foetal life, immature lymphocytes enter the thymus. Once within, the genes which encode for the variable region of the T cell receptor are sequentially rearranged. This

results in thousands of T cells with different receptors, recognising different MHC/antigen combinations. Those which recognise foreign antigen bound to self MHC are preserved, while those recognising non-self MHC or self antigen are eliminated.

During the maturation process T cells acquire the surface markers CD3, CD4, CD8 and differentiate into helper and cytotoxic/suppressor cells.

### B Cells

These bone marrow derived cells are the immunoglobulin factory. The immunoglobulin which is bound to the surface binds antigen, and with T cell help, the B cells proliferate. Once stimulated with antigen, IgM producing plasma cells are formed, while other B cells become memory cells. If exposed to the same antigen again, these produce mature plasma cells, and a larger IgG response. B cells respond to polysaccharide antigen (surrounding encapsulated organisms) without T cell help, but the response is limited, resulting mainly in IgM, and no B cell memory.

## WHY ARE NEONATES AND INFANTS PRONE TO INFECTION?

Cells of the immune system develop early in foetal life. However, the main defences at this stage are the physical barriers of the uterus and the placental barrier. Infants born prematurely lack the same degree of physical protection, with thinner skin and less effective mucous membranes, in addition to immature immune responses.

By the time of birth at term, physical barriers have matured. Acute phase proteins are present, but neonates lack terminal components of complement activation, particularly C9. These are important for lysis of gram-negative bacteria, such as *E. coli*, to which infection they are particularly susceptible.

Neutrophils comprise only 10% circulating white cells in the second trimester, but 50–60% by term. However, neonates often respond to sepsis with neutropenia. Their neutrophils do not adhere as well to the endothelium, inhibiting migration. Chemotaxis and phagocytosis are less efficient, but bacterial killing and antigen presentation is as good as in adults.

T cell numbers are greater in infancy than in adult life, but the majority of them are naïve, whereas in adults, they are primed to proliferate rapidly following repeated antigen exposure. Cytokine production, cytotoxicity, delayed hypersensitivity, and B cell help are all reduced.

During the last trimester, maternal immunoglobulin (IgG) crosses the placenta, conferring passive immunity to the neonate. B cells are present at birth, and can differentiate



Fig. 24.5: Normal level of immunoglobulin with age

into IgM producing plasma cells. The ability to produce T cell dependent responses to protein antigens such as tetanus toxoid, and Hib conjugate is also present at birth. However, development of IgG producing plasma cells, and T independent responses are delayed until around 2 years of age. As the normal response to polysaccharide antigens, such as those in the cell wall of encapsulated organisms requires B cells to work without T cell help, this may account for the increased susceptibility of infants to infections with organisms such as *Pneumococcus*, *Neisseria meningitidis*, and *Haemophilus influenzae*. Normal immunoglobulin levels rise with age (Fig. 24.5). IgA is the latest antibody to be produced, and IgA producing plasma cells are not found until around the age of 5.

## NUTRITION AND IMMUNITY

The association of undernutrition and increased susceptibility to infections, particularly respiratory and gastrointestinal infection, has long been recognised. The reasons are multifactorial, in that conditions leading to undernutrition are also associated with over-crowding, lack of sanitation and access to clean water, increased risk of prematurity, and lack of vaccination. In turn, episodes of infection increase metabolic demand for nutrients and decrease appetite and intake, thus increasing malnutrition in a vicious cycle.

Bacterial infections, such as pneumonia, tuberculosis, gram-negative gastrointestinal infections are particularly common in children sufficiently malnourished to be hospitalised. Mortality from measles due to giant cell pneumonia is high. These children may suffer from severe herpes fungal and parasitic infections.

Undernutrition has adverse effects on all parts of the immune response. Protein-calorie malnutrition (PCM) leads to atrophy of the skin and mucous membranes. Vitamin deficiencies, particularly A (xerosis), C (scurvy), E and B (dermatitis, cheilitis), and deficiencies of trace elements such as iron (cheilitis), zinc (acrodermatitis), selenium and copper can disrupt these physical defences.

Protein-calorie malnutrition compromises lysozyme and interferon production, and components of complement, particularly C3. C4, however, tends to be raised. Leptin levels are reduced. This hormone promotes Th1 responses, and has an anti-apoptotic effect, important for normal haemopoiesis. Phagocytic function is decreased, with impaired bacterial killing, despite increased production of reactive oxygen species. NK function is reduced in PCM, and deficiencies in zinc, selenium, and vitamins A and D.

T cell responses are profoundly affected by PCM, and also vitamin A, zinc, selenium and iron deficiency. Thymic atrophy occurs, together with depletion of lymph node germinal centres. There can be lymphopenia with decreased CD4/CD8 ratio. Reduced delayed hypersensitivity responses and T cytotoxicity leads to lack of response to BCG and susceptibility to tuberculosis, reactivation of viral infections and other opportunistic infections.

In contrast, levels of immunoglobulin are usually well maintained. There can be particularly high levels of serum IgE, which is not necessarily related to helminth infestation, but probably represents dysregulation. Antibody responses are usually preserved, although some studies suggest decreased response to vaccines in severe PCM.

## PROBLEMS WITH THE IMMUNE SYSTEM

### How Many Infections is too Many?

The normal range for number of infectious episodes/year in an immunocompetent child is extremely wide, and dependent on factors including the risk of exposure to environmental pathogens (e.g. water-borne organisms, malaria), over-crowding, and exposure to other children, either at home or in nurseries or school. Lack of breast feeding and parental smoking influence rates. Children with medical conditions such as sickle cell syndrome, nephrotic syndrome, cystic fibrosis, are atopic, have injuries breaching physical barriers, such as compound fractures or burns, or who have implanted foreign bodies will have an increased risk. Immune dysfunction may also be secondary to malignant disease, immunosuppressive agents, infections such as HIV, EBV, or result from splenectomy.

### When to Suspect Immune Deficiency

An underlying problem with immunity should be suspected in children who have more frequent episodes of infection than expected, given the factors above. Children may suffer recurrent infections with a particular type or organism, or the course of an infectious episode with a particular pathogen is unusual in length, severity, or character. Children may become infected with organisms which would not usually be pathogenic (opportunistic organisms).

Immune deficiency should also be considered in children who have other features of a syndrome known to be associated with immune problems, such as di George, ataxia telangiectasia (AT), Wiskott Aldrich, etc. Early diagnosis (before the onset of severe infections) can sometimes be achieved by taking note of abnormal results of tests performed for other reasons, for example, neutropenia or lymphopenia from a full blood count.

## The Diagnosis of Immune Deficiency

### The History

From this information, a number of patterns may emerge: invasive bacterial infections, problems with opsonisation (complement, immunoglobulin), phagocyte numbers or function (chemotaxis, phagocytosis and killing), recurrent infection with encapsulated organisms, etc.

A careful history is the key to diagnosis throughout medicine, and immune deficiency is no exception. A detailed history should include:

- Documentation of episodes of infection, their frequency, their course, character, duration, treatment given, effect of treatment, necessity for hospitalisation, clinical diagnosis given, and whether confirmatory tests performed.
  - From this information, a number of patterns may emerge: Immunoglobulin, phagocyte numbers or function (chemotaxis, phagocytosis, killing, etc.).
    - *Recurrent infections with encapsulated organisms*: Antibody deficiency, complement defects (especially recurrent meningococcal disease), etc.
    - *Recurrent/persistent/severe viral infections*: Cytotoxic T cells, NK cells, etc.
    - *Fungal infections*: Neutrophil number/function, T cell function, etc.
    - *Opportunistic pathogens, e.g. pneumocystis*: T cell function
- Periodicity of infections: Problems occurring at 3 weekly intervals, particularly associated with mouth ulcers is suggestive of cyclical neutropenia
- Age of onset:
  - From birth suggestive of cellular defect, e.g. congenital neutropenia, T cell immunodeficiencies
  - 6–9 months: recurrent sinopulmonary infection suggestive of antibody deficiency
  - After 2 years of age—consider common variable immune deficiency.
- Birth history:
  - Gestation
  - Birth weight: intrauterine growth retardation is associated with nutritional immune dysfunction and specific syndromes
  - Neonatal problems:

- Jitteriness/seizures due to hypocalcaemia or heart failure/cyanosis due to congenital heart disease may indicate di George's
- Petechiae/bleeding from cord in Wiskott Aldrich's
- Severe erythroderma in congenital graft versus host disease
- Neonatal sepsis in reticular dysgenesis and severe neutropenia and severe T cell defects
- Time of cord separation: Delay associated with lymphocyte adhesion defect
- Other medical problems:
  - Growth problems
    - Severe failure to thrive in T cell defects
    - Short stature in Bloom syndrome
  - Developmental delay/neurological problems
    - Ataxia telangiectasia
    - Purine nucleoside phosphorylase deficiency
    - HIV
  - Skin problems
    - Eczematoid dermatitis and abscesses in Hyper-IgE
    - Recurrent abscesses in CGD
    - Eczema and petechiae in Wiskott Aldrich's
    - Skin sepsis in antibody deficiency, neutrophil disorders, complement defects.
- Immunisations given and reactions:
  - Neonatal BCG: Reaction/dissemination—T cell deficiency, interferon gamma/IL12 dysfunction
  - Symptomatic disease following live vaccine, e.g. measles—T cell function
  - Abscess/reaction at site; neutrophil function complement.
- Allergies
- Current and past medication, including “over the counter” and alternative/herbal remedies
- Family history:
  - Family members with similar features
  - Deaths early in life
  - Consanguinity.
- Social history:
  - Housing
  - Occupants of house
  - Attendance at nursery/school
  - Risk behaviours for blood-borne virus infection
  - Parental occupations
  - Smoking
  - Pets/animals/birds.

### Diagnostic Tests

Selection of appropriate tests should depend upon the differential diagnosis obtained as a result of the history and examination, and also on the resources available.

## Full Blood Count

*Haemoglobin* is reduced in chronic infection and inflammatory conditions.

*Neutrophil count* will identify chronic neutropenia. Serial tests over a 3 weeks period are needed to diagnose cyclical neutropenia. A neutrophil leucocytosis is seen in disorders of neutrophil function such as chronic granulomatous disease (CGD) and lymphocyte adhesion defect.

*Lymphocyte count* is low in T cell immunodeficiencies such as Severe Combined Immunodeficiency. Note that the lymphocyte count is normally higher in infants, so values persistently below  $2.8 \times 10^9/L$  should prompt further investigation.

*Platelet count* and platelet size is reduced in Wiskott Aldrich syndrome.

*Blood film* microscopy may identify Howell Jolly bodies in asplenia.

## TESTS OF CELL MEDIATED IMMUNITY

### Skin Testing

Delayed hypersensitivity is mediated by cell mediated responses, and so it is possible to test for this *in vivo*. The problem in infants and children under 2 years is to find a suitable antigen to which they have previously been exposed and sensitised. Children who have had BCG may respond to tuberculin, and those who have had tetanus immunisation may respond to tetanus toxoid. Candidal antigen may also be used. Testing involves an intradermal injection of the antigen, and recording of the resulting erythema and induration at 24–48 hours.

### Lymphocyte Subset Quantification

If monoclonal antibodies labelled with fluorochrome are generated against lymphocyte surface markers, they can be used to identify lymphocyte subsets using a flow cytometer or fluorescence activated cell scanner (FACS) machine. The commonest monoclonals used are against CD3 (all mature T cells), CD4, CD8, CD19/20 (B cells) and CD16/56 (NK cells). Normal ranges for numbers and proportions vary with age.

### Lymphocyte Function

*In vitro*, this can be assessed by incubating lymphocytes with mitogens such as phytohaemagglutinin and pokeweed mitogen. The degree of proliferation is measured by assessing the uptake of tritiated thymidine, compared to that of a normal control sample.

## Cytokine and Receptor Assays

These are not widely available, but they can diagnose rare immunodeficiencies.

## TEST FOR HUMORAL IMMUNITY

### Immunoglobulin Assays

Normal plasma concentration of immunoglobulin classes also vary with age. Low levels of all classes are found in T cell immunodeficiencies, such as severe combined immunodeficiency, and in antibody deficiencies such as X-linked agammaglobulinaemia (XLA). High levels are found in chronic infection, CGD and HIV.

### B Cell Function

B cell function can be assessed by measuring the titre of antibody to a specific antigen following exposure to the antigen, for example, anti-tetanus antibody, pre- and post-vaccination. Antibody to *Pneumococcus* can also be measured, but as this is a polysaccharide antigen, children under 2 years do not normally respond.

### Phagocyte Function

There are no reliable tests of chemotaxis. The respiratory burst can be measured using the nitroblue tetrazolium test (NBT) during which normal cells phagocytose the colourless dye and reduces it to a purple compound. Neutrophils from children with CGD phagocytose normally, but there is no colour change.

### Complement Function

It is possible to measure levels of individual complement components—the most straightforward being C3 and C4. CH50 is a dynamic assay of total haemolytic complement, and is reduced in defects of the classical pathway.

### Genetic Tests

Chromosome analysis can diagnose conditions such as di George syndrome, which is associated with a deletion on q22. The exact genetic defect has been identified for some inherited immune deficiencies, and in these analyses of DNA or assay of the gene product (e.g. B tyrosine kinase in XLA) can be performed.

## PRIMARY IMMUNODEFICIENCY DISORDERS

These conditions are individually quite rare, with an estimated prevalence of 1 in 5,000 population. The commonest are antibody deficiencies, accounting for approximately 65% total, cellular deficiencies comprise 20%, phagocytic disorders 10%

and complement disorders 5%. Those with an autosomal recessive mode of inheritance may be more common in societies with a high incidence of marriage within the extended family.

### Severe Combined Immune Deficiency

Severe combined immune deficiency (SCID) is a group of conditions characterised by low or absent T cells and hypogammaglobulinaemia. B and NK cell numbers may be normal or absent, depending on the type. It may present with congenital graft versus host disease due to engraftment of maternal T cells, or following neonatal transfusion of non-irradiated blood. More commonly, the infant develops recurrent or chronic mucocutaneous candidiasis, chronic diarrhoea and failure to thrive due to persistent viral gastroenteritis, and chronic respiratory viral infection (e.g. RSV, adenovirus) leading to respiratory failure. Acute sepsis can occur, as can opportunistic infection with agents such as pneumocystis and cytomegalovirus. Without treatment (bone marrow transplantation) it is unusual to survive beyond the first year of life. There are X-linked (e.g. common gamma chain deficiency) and autosomal recessive (e.g. ADA deficiency) forms of the condition, and for some the underlying defect is unknown.

### Di George Syndrome

The main features of this syndrome are conotruncal cardiac anomalies (e.g. interrupted aortic arch, truncus arteriosus), hypocalcaemia, and hypoplastic or absent thymus. Children with this syndrome have characteristic facies, with hypertelorism, antimongoloid slant of the eyes, micrognathia, cleft or high-arched palate, and ear malformations. These defects are due to failure of migration of neural crest cells into the 3rd and 4th pharyngeal pouches early in embryological life. This is commonly associated with a microdeletion on chromosome 22 (q22.1). Many cases are sporadic, but there is, therefore, an autosomal dominant inheritance.

Most children present with symptoms of their congenital heart disease or with neonatal hypocalcaemia, and although they may have low T cell numbers compared with normal infants, immune function is well-preserved. However, those with absent or severely hypoplastic thymus can have features of severe T cell immunodeficiency similar to SCID. They can have normal immunoglobulin levels, but reduced specific antibody production. There is also an increased risk of autoimmune disease.

### X-linked Agammaglobulinaemia

This condition is due to a lack of the enzyme B tyrosine kinase (btk) which is essential for B cell maturation. Circulating B cell numbers are very low or absent, as are levels of

circulating immunoglobulin. Children are normal at birth, protected by passive maternal antibody, but develop recurrent bacterial infections, particularly sinopulmonary infections, usually becoming symptomatic between 6 and 18 months of age. As T cell function is normal, they cope with childhood exanthemata such as varicella normally. Immunoglobulin can be replaced with regular intravenous or subcutaneous infusions, and in those who are treated adequately, prognosis is good. Ongoing problems with chronic sinusitis, purulent rhinitis, and conjunctivitis, can occur despite replacement, and chronic lung disease is particularly likely in those not maintaining adequate trough levels of immunoglobulin.

### CD40 Ligand Deficiency

This condition is also X-linked and shares many characteristics with XLA. However, CD40 ligand is a T cell receptor, binding with CD40 on the B cell to enable B cell proliferation and isotype switching. Children with this condition have normal numbers of circulating B cells, and normal or high levels of serum IgM, but absent IgG, IgA and IgE. This T cell ligand has other functions in host defence, in addition to B cell stimulation, so unlike XLA, children can present with pneumocystis carinii pneumonia and fail to clear pathogens such as *Cryptosporidium*. Even with immunoglobulin replacement, the prognosis is much poorer. This is due to the risk of liver failure due to sclerosing cholangitis, which may result from chronic biliary infection with organisms such as *Cryptosporidium*, and of malignancy, particularly abdominal malignancies.

### Common Variable Immunodeficiency

This is another form of antibody deficiency, but unlike XLA, symptoms can start at any age, but after 2 years at the earliest. The most common presentation is with recurrent or chronic sinopulmonary infection, which can lead to chronic lung disease. These children have B cells, but low levels of immunoglobulin, and poor or absent specific antibody responses. In addition to infections, they may develop granulomatous disease or autoimmune features, and have an increased risk of malignancy. Treatment is with immunoglobulin and antibiotic prophylaxis.

### Chronic Granulomatous Disease

This is a disorder of phagocytes in which there is a defect in NADPH oxidase, the enzyme involved in the respiratory burst. There are both X-linked and autosomal recessive forms of the disease. Children with CGD are at particular risk of infection.

With catalase positive bacteria (such as *Staphylococcus* organisms and coliforms) and fungi such as *Aspergillus*, they can present with recurrent lymphadenitis, invasive bacterial



infection such as pneumonia, liver abscess, osteomyelitis or life-threatening sepsis. Prophylactic antibiotics and antifungals have improved prognosis, but many succumb to invasive fungal infection in the second and third decades of life.

### Complement Deficiencies

These are individually very rare, and tend to present with recurrent bacterial infection, due to poor opsonisation, glomerulonephritis, or features suggestive of rheumatological disease. Some, such as properdin deficiency, lead to increased susceptibility to infection with encapsulated organisms, particularly *Neisseria meningitidis*, which should be considered if children present with recurrent meningococcal disease. It has X-linked inheritance.

### Wiskott Aldrich Syndrome

This results from a mutation on the X chromosome of a gene encoding for WAS protein. This protein is important for the normal development of the cytoskeleton, and plays a role in apoptosis. The main features are thrombocytopenia, recurrent infections and eczema. Those affected often present in the neonatal period with petechiae and bleeding. Not only are platelet numbers reduced, but they are smaller than normal and function less well, so bleeding may be more severe than would be expected from the platelet count alone. Boys suffer recurrent bacterial infections, such as otitis media, pneumonia, and meningitis, particularly with encapsulated organisms. They also suffer from viral infections, such as recurrent herpes simplex and severe varicella. Their eczema has the same characteristics as classic atopic eczema. Other atopic symptoms such as food allergy can develop. Some boys develop autoimmune problems, and the long-term risk is from malignancy, particularly EBV driven B cell lymphoma. Treatments include splenectomy, intravenous immunoglobulin, and antibiotic prophylaxis. However, bone marrow transplant can be curative.

### Hyper IgE (Job's) Syndrome

Children with this condition suffer from recurrent severe staphylococcal infection, particularly skin abscesses and pneumonia. They have a dermatitis which may be diagnosed as eczema, but the characteristics and distribution of the lesions are different from atopic eczema. Children can have coarse facies and skeletal abnormalities. As the name suggests, levels of serum IgE are extremely high (often many thousand IU/L). The gene and underlying defect for this condition are unknown, and there is no specific treatment apart from long-term prophylactic anti-staphylococcal antibiotics.



Fig. 24.6: Telangiectasia on the bulbar conjunctivae

### Ataxia Telangiectasia

This is caused by a mutated gene on chromosome 11, which encodes for a protein which is important for repair of double stranded DNA. The cells of those affected are therefore abnormally sensitive to irradiation. Children are normal at birth, and early development is normal. They tend to drool, and speech is slow. They begin walking at the usual age, but become more wobbly. Unlike many other cerebellar disorders, the ataxia of AT results in a narrow based gait, and children have difficulty keeping their head and trunk still when standing. From around the age of 7 years there is progressive neurological deterioration. Conjunctival telangiectasia are often the first to appear, with cutaneous lesions appearing between the ages of 3 and 6 years (Fig. 24.6).

The immunodeficiency associated with condition is variable, both in clinical manifestation and laboratory findings. Children with AT may suffer from severe or recurrent sinopulmonary infection, and also chronic or recurrent warts. They commonly have low or absent IgA levels, but can have low specific antibody responses to polysaccharide antigens, or T lymphopenia. They have a very high risk of cancer, chiefly leukaemias and lymphomas, but other solid tumours can occur. Most sufferers die in the second or third decade from chronic lung disease or malignancy.

## ALLERGY

*Allergy* can be defined as an immunologically mediated response whose effects are detrimental to the host.

These responses are much more common in individuals described as *atopic*. *Atopy* is highly genetic and characterised by an individual or familial tendency to become sensitised to common protein allergens at normal levels of exposure. This

response is usually mediated by IgE. Atopic individuals tend to have higher levels of circulating IgE than those who are non-atopic.

*Hypersensitivity* can be defined as the development of reproducible symptoms and signs following exposure to a particular stimulus at a dose which would normally be tolerated (e.g. peanut allergy). However, it can also be used more widely to describe allergic reactions, some of which are universal (e.g. reaction to mix-matched blood).

## THE IMMUNOLOGY OF ALLERGIC DISEASES

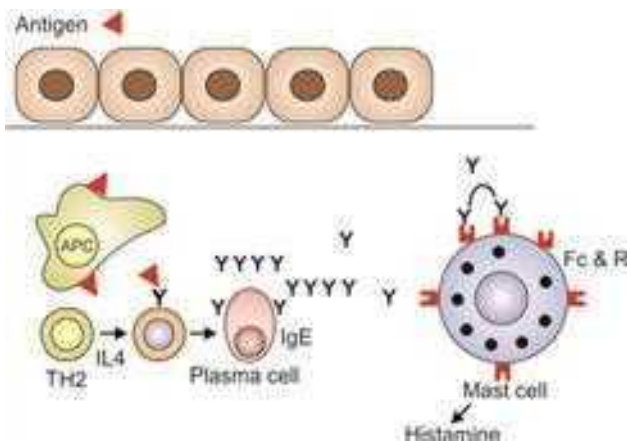
Traditionally, hypersensitivity reactions have been classified into four types. Although we now recognise that many complex interactions occur between different parts of the immune system, it is still a useful way of understanding allergy.

### Type I (Immediate/Anaphylactic)

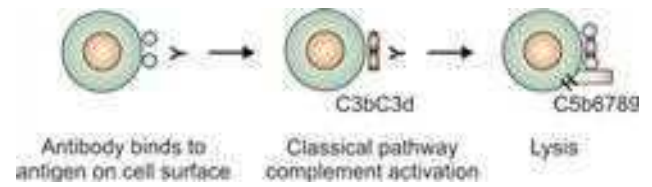
Symptoms occur within minutes/hours of exposure to the allergen, which forms a complex with specific IgE and is bound to the surface of effector cells, such as mast cells (Fig. 24.7A). This leads to the release of chemical mediators which cause the changes associated with observed symptoms and signs, for example, vasodilatation, capillary leak, bronchoconstriction, increased gut peristalsis. This is the mechanism behind peanut allergy, drug reactions, allergic rhinitis and acute asthma.

### Type II (Cytotoxic)

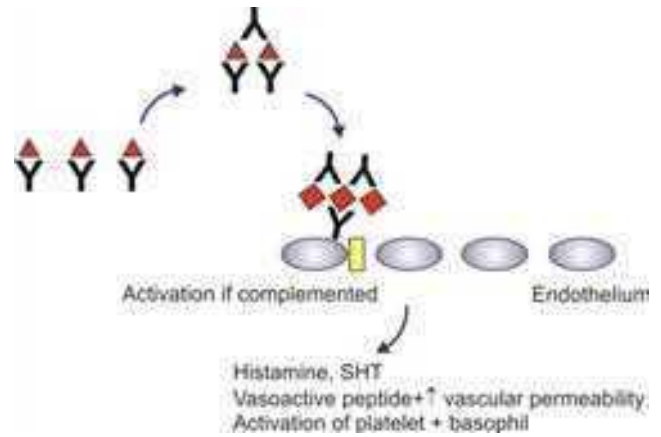
In this reaction, antibody (IgG or IgM) binds directly to tissue bearing the specific antigen, resulting in complement activation and tissue damage (Fig. 24.7B). Examples are transfusion reactions, to which all are susceptible, but they also occur in diseases such as autoimmune haemolytic



**Fig. 24.7A:** Type 1 reaction. Pathogenesis of type 1 hypersensitivity. Exposure to antigen IgE production, mast cell sensitisation



**Fig. 24.7B:** Type II reaction. Pathogenic mechanism in type II H



**Fig. 24.7C:** Type III reaction

anaemia, Goodpasture's syndrome, and some drug induced cytopenias.

### Type III (Arthus/Immune Complex)

In these reactions, antibody is bound to antigen to form immune complexes, some of which are cleared by the reticuloendothelial system. However, some are deposited in blood vessels or tissues, inducing complement activation and tissue damage (Fig. 24.7C). This is the pathogenesis of serum sickness and glomerulonephritis.

### Type IV (Delayed/Cell Mediated)

Unlike the first three types, delayed hypersensitivity is not mediated by antibody, but by T cells. The maximum inflammatory response may not occur until 48–72 hours after exposure. As a result of interaction between local antigen presenting cells (principally dendritic cells) and T cells, T cells proliferate and produce cytokines which mediate a local inflammatory response. Reactions are universal following exposure to antigen such as poison oak or poison ivy. Induction of this type of reaction is the basis of the tuberculin skin test (Mantoux).

Some allergic conditions involve both immediate and delayed hypersensitivity responses to the same stimulus. For example, exposure to egg in a young child may cause urticaria and angio-oedema within minutes, due to IgE mediated hypersensitivity. Forty eight hours later, a flare of atopic eczema may result from the influx of mononuclear cells associated with a type IV response (Fig. 24.7D).

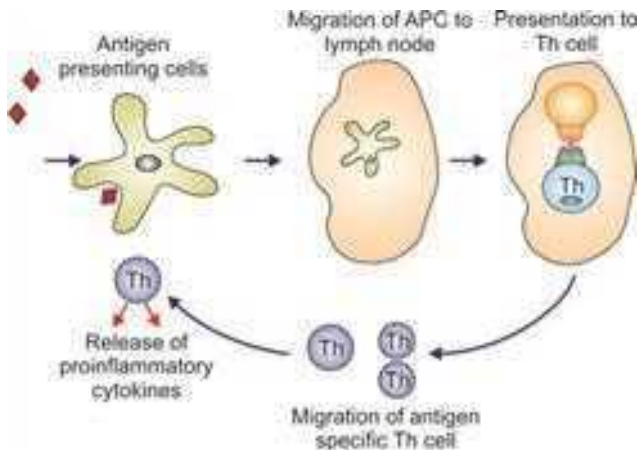


Fig. 24.7D: Type IV reaction

- $H_3$  receptors modulate cholinergic sensory nerves and inhibit histamine release from mast cells.

### Leukotrienes

These are fatty acids whose active inflammatory metabolites cause vasodilatation, swelling of the mucosa, increased mucous production and bronchoconstriction. Metabolism is governed by the 5-lipoxygenase pathway, which can be stimulated by certain antigens. They have an important role in the pathogenesis of asthma and allergic rhinitis.

### Other Chemical Mediators

These include kinins, complement, interleukins and cell adhesion molecules.

## MEDIATORS OF THE ALLERGIC RESPONSE

### T and B Cells

IgE producing plasma cells develop following T cell stimulation, first of all by cytokines (chiefly IL4) released as a result of interaction between antigen (allergen) presented in association with class II MHC and T helper cells. The interaction between CD40 ligand on the TH2 cell and the CD40 B cell receptor is also necessary. In atopic children, there is an increased number of allergen-specific T cells, which when stimulated, produce IL4, IL5 and IL13. These cytokines induce allergic inflammation by their action on mast cells, basophils and eosinophils.

### Mast Cells, Basophils and Eosinophils

These play a large role in the allergic response and resulting inflammation. Their functions have already been outlined.

### Histamine

This is the major mediator of type I hypersensitivity. Different tissues have different histamine receptors, determining the response.

- $H_1$  receptors are found in blood vessels, and smooth muscle of the respiratory and gastrointestinal tract. The action of histamine on these receptors results in increased vascular permeability, GI muscle contraction, bronchoconstriction, increased chemotaxis, and decreased chemokinesis
- $H_2$  receptors are found in the gastric mucosa, the heart, uterus and central nervous system. Stimulation results in increased gastric acid and pepsin production, increased chemotaxis and chemokinesis, with a negative effect on lymphocytotoxicity, and on further histamine production
- Both types of receptor contribute to vasodilatation, flushing, headache, tachycardia, hypotension, and the wheal and flare reaction

## EPIDEMIOLOGY

The prevalence of atopic disease varies greatly throughout the world, being much more common in the developed world with “Western” lifestyle. There has also been a dramatic increase in prevalence, particularly in the developed world over time. The rise in sensitisation to aeroallergens probably began in the 1920s, but the large increase in symptomatic disease started in the 1960–70s, with some evidence that the rates have now stabilised, with rates of asthma between 20% and 40%, depending on the criteria used, compared with 2–3% in the developing world. Similarly rates for hay fever, at the age of 16 years are around 20–25% in the UK, and 6% for atopic eczema. Within the developing world, a shift from rural to urban habitat results in increased prevalence, and immigrants from areas of low to high prevalence reach rates similar to the indigenous population in a generation.

### Why is Atopic Disease Increasing?

We believe that the immune system is “primed” to generate predominantly Th1 or Th2 responses to a given stimulus early on in life. This process may therefore be influenced by the nature of the antigens to which the infant is exposed at this stage. In the West, the burden of infectious disease is much lower than in the developing world now, and in Western society in the past. Moreover, even in developing countries where the overall prevalence is still low, there is an increased risk associated with change from rural to urban environment. Some studies have suggested that large family size, attendance at day nursery, and living on a farm, particularly with animals are all associated with a lower rate of atopic diseases. The reasons for these differences are complex. A popular theory is the “hygiene hypothesis”, which in some ways is a misleading title, as it could imply that good standards of hygiene are bad for your health, which is far from the case. It is certainly true, however, that one of the most striking differences between rural life

in a developing country, and Westernised society, is in the nature of exposure to microbial and parasitic organisms. The degree of exposure early in life to agents such as bacterial endotoxin, environmental mycobacteria, and to helminths, particularly hookworm, may be important for the manner in which mechanisms which regulate the immune response develop.

### Clinical Presentation of Allergic Disease

These include acute anaphylaxis, food allergy and atopic diseases such as asthma, eczema, allergic rhinitis and conjunctivitis. Allergic asthma and eczema have been described elsewhere in the sections on respiratory medicine and dermatology respectively (Chapters 6 and 14).

### Acute Immediate Hypersensitivity and Anaphylaxis

In some references, the term anaphylactic is used to describe type I hypersensitivity reactions of any severity. Here anaphylaxis is defined as a sudden life threatening systemic reaction which is immune mediated. As such it is an acute medical emergency. It usually results from a type I hypersensitivity reaction, mediated by histamine, and other active chemicals released during IgE associated mast cell degranulation. Type III reactions can sometimes give a similar clinical picture.

If exposure to the allergen has been cutaneous or mucosal, there may initially be local symptoms at the site of contact, such as tingling lips and tongue with local swelling, sneezing, conjunctival irritation or localised urticaria. Urticaria may progress to become widespread, with intense itch. There may be angio-oedema with facial swelling, hoarse voice and a feeling of a lump in the throat, with coughing and choking, if this affects the upper airways. Bronchospasm may also lead to audible wheeze. Some children vomit profusely or complain of abdominal cramps or diarrhoea.

In the most severe cases, the onset is sudden and heralded by a “sense of impending doom”, and a sudden feeling of weakness. The child experiences palpitations, becomes cold and clammy, with poor peripheral perfusion. They may develop severe difficulty in breathing, either secondary to upper airways obstruction, or to severe bronchospasm. This is followed by circulatory collapse and unconsciousness. Although uncommon, particularly in childhood, deaths do occur.

Anaphylaxis can result from exposure of the sensitised child to food allergens, such as peanut. It can also be triggered by venoms, such as bee and wasp, or plants, such as strawberry and natural rubber latex. A wide variety of drugs can cause it, particularly antibiotics, such as penicillin, sulphonamides or anaesthetic agents.

### Anaphylactoid Reactions

The term anaphylactoid is used to describe a clinical picture which closely resembles anaphylaxis, i.e. urticaria/erythema, respiratory difficulty, shock, but in which the pathogenesis is not immune mediated. It may result from direct action of chemicals such as drugs on cells, leading to the release of vasoactive peptides. Vasoactive agents may also be released through stimulation of intermediate pathways, such as the complement cascade. It may result from drug interactions, or from infusion of large volumes of plasma products, in which immunoglobulins form aggregates in the circulation. Reactions due to underlying pathology (e.g. tumours), or surgical stimulation causing release of vasoactive peptides is very rare in children. Very occasionally, the cause may be psychosomatic, and the possibility should be considered in teenage patients, when no other explanation can be found.

### FOOD ALLERGY

While food is essential to our survival, it can also cause a number of well-recognised adverse events. Moreover, children and their families may attribute all sorts of symptoms which they suffer to “food allergy”. Some beliefs regarding the association of certain foods and ill-health are routed deep in the culture of the society to which the family belongs. Many have their base in philosophies other than “conventional” medicine, and are not amenable to application of the scientific method to explore.

There are a number of recognised mechanisms for adverse reactions to food, only one of which is IgE mediated immediate hypersensitivity. Others are immune mediated, but not through IgG. Examples include cow's milk protein intolerance, and gluten enteropathy (coeliac disease). Some foods can lead directly to histamine release, or actually contain histamine, such as strawberries and tomatoes. Localised urticaria after ingestion is commonly described in atopic children, particularly those with eczema, who show no evidence of IgE mediated sensitivity. In some cases symptoms are due to pharmacological effects of ingredients, such as caffeine in soft drinks, leading to vomiting and diarrhoea, or tartrazine (yellow colouring used in soft drinks) causing bronchospasm, particularly in those with underlying asthma. Reactions can reflect lack of necessary enzymes, such as disaccharidase deficiency in lactose intolerance, or in inborn errors of metabolism, such as galactosaemia. Neurological symptoms following food ingestion can result from build up of a toxin within the food, such as in scombrototoxic fish poisoning, or in botulism, due to contamination of food with *Clostridium*. To some children, certain food smells act as noxious stimuli leading to retching and vomiting and aversion to that food. However, for the purpose of this discussion, we will concentrate on “true” IgE mediated allergic reactions.

Like other atopic disorders, the incidence of food allergy has been increasing. This is reflected in the number of children presenting to clinics with symptoms, but also in admissions to hospital with significant reactions or anaphylaxis. Death from such reactions can occur, but is extremely rare in childhood (0.006/100,000 children aged 0–15/year in the UK). The prevalence in the UK is quoted in the region of 2–6%, with peanut allergy at 0.8%. Many children with food allergies have other atopic diseases. A third of children with atopic eczema in infancy and 1 in 10 children with asthma report food related symptoms.

In many parts of the world, the commonest food allergens in infants and young children are eggs and milk. There is, however, a wide geographical variation, not only in the incidence of food allergy, but also in the foods causing these reactions. In the UK and Australia, peanuts and tree nuts are the next most common. Fish is the commonest allergen in Italy. Sesame allergy is common in the Middle East, seafood in Japan and Singapore, and legumes (lentils, peas, beans) in India and Pakistan.

Children who are allergic to one food allergen have an increased likelihood of also being allergic to related foods. For instance, the majority of milk allergic children are also allergic to egg. Allergy to pulses can be associated with peanut allergy. Those with peanut allergy may also be allergic to other nuts and seeds (e.g. sesame seed); although an allergy to one individual nut (e.g. brazil nut) can occur. There can also be cross-reactivity between sensitivity to inhaled allergens, and foods. For example, allergy to birch pollen is associated with reactions to apples, pears and other fruit, and also to hazelnuts. Reactions to melon and banana and ragweed sensitivity are similarly related.

The prognosis for food allergy varies, depending on the allergen. Ninety per cent cow's milk allergic infants will become tolerant by the age of 3 years. Egg allergy commonly resolves before school age. However, allergies to pulses and nuts are usually life long, with only around 5% resolving by the age of 7 years.

### The Oral Allergy Syndrome

Children with this condition develop an itchy mouth and tongue, sometimes with localised urticaria and swelling after eating a variety of fresh fruit or vegetables. The same foods may be eaten if they are peeled and/or cooked, as the sensitivity is to proteins which are destroyed by this process. A common association is that of hay fever symptoms in the spring and early summer due to allergy to birch pollen and symptoms on eating whole apple, while the child can still drink apple juice. Although symptoms can be unpleasant, and their precipitants best avoided, these reactions do not carry a risk of anaphylactic shock.

### Exercise Induced Anaphylaxis

This is very unusual before teenage years. It occurs when ingestion of a particular food is followed within a few hours by moderate to intense exercise. Both elements are necessary to produce the reaction, and so the causal relationship with the food allergen may not be made, if a history of tolerating the same food on other occasions (when such exercise has not taken place) is elicited. Changes in metabolism associated with the exercise result in the mast cells becoming more activated, and thus more likely to degranulate after a given IgE/allergen stimulus. This effect can also be seen in children who normally suffer only mild reactions after exposure to a food allergen but who may develop anaphylaxis following the same degree of exposure, following exercise.

### Latex Allergy

Allergy to natural rubber latex is strongly associated with exposure to settings where a lot of latex material is used. Thus health care workers and those exposed to industrial latex have a high risk of developing sensitivity. In children, high risk groups are those with spina bifida or with genitourinary abnormalities, which is likely to be due to repeated exposure of mucous membranes to latex urinary catheters. Children with a history of repeated surgery in the first year of life are also at risk, presumably because of repeated exposure to latex gloves and other latex containing equipment. Because of this problem, other materials, such as nitrile, are being substituted for latex where this is possible.

Around half of the children with latex allergy also experience symptoms on exposure to various foods. These include banana, avocado, chestnut, potato, kiwi and other tropical fruits. In children with allergies to these foods, the possibility of latex allergy should therefore be considered.

Latex is used very widely in clothing, for mattresses, bicycle or wheelchair tyres, balls, erasers, computer mouse mats, etc. Total avoidance of all such products is almost impossible, but thankfully seldom necessary. While contact with the skin can lead to urticaria or contact dermatitis, severe reactions usually occur only after significant mucosal or systemic exposure. The main risks therefore surround episodes of medical or dental care. If latex allergic children need such care, it is very important that every effort is made to ensure the environment is latex free. Where the risk of exposure cannot absolutely be eliminated, for example, during major surgery, pre-medication with hydrocortisone and antihistamines is advised, with careful observation peri- and postoperatively.

### Allergic Rhinitis

Allergic rhinitis is very common in industrialised societies, with a prevalence of up to 40% in children. Some suffer

symptoms all year round (perennial rhinitis), whereas for others the problem is restricted to times of year when there is exposure to the causal allergen (seasonal rhinitis). The allergens responsible for perennial rhinitis tend to be those encountered in an indoor environment, such as house dust mite, animal dander, etc. Those developing seasonal rhinitis in the spring are allergic to tree pollen, whereas symptoms of grass pollen allergy peak in the mid-summer. Those who have their main problems in the autumn may be allergic to leaf mould or weed pollen.

There are two phases of response. After exposure in a sensitised child, there is a type I reaction, which in the nasal passages leads to nasal vasodilatation, capillary leak and increased mucus production. This leads to nasal congestion and a watery runny nose, with itching and sneezing. In around 50% of sufferers, this is followed by a late response, induced by inflammatory cells, causing ongoing nasal congestion, with runny nose and postnasal drip, which may last for days. Nasal symptoms are often accompanied by itching of the eyes (allergic conjunctivitis), ears, throat and palate.

Although the consequences are rarely life-threatening, these symptoms are a major cause of morbidity in school aged children. Those who are severely affected with chronic nasal obstruction suffer recurrent or chronic headache, tiredness and sleep disturbance, sometimes resulting in sleep apnoea. It can lead to day time somnolence, poor concentration and poor school performance. The effect on children's emotional and psychological development can therefore be profound.

There is a close association between allergic rhinitis and asthma. Half of children with asthma also have rhinitis, and around a third of children with rhinitis also have asthma. Furthermore, allergic rhinitis is a risk factor for the subsequent development of asthma.

## DIAGNOSIS OF ALLERGY

### History

Once again, a careful history is the key to diagnosis of allergy. This should include the nature of symptoms experienced, the evolution of symptoms, from the first symptom experienced onwards, time taken to resolution, and whether any treatment was administered. Details of exposure to potential allergens should be obtained, and the length of time between the suspected exposure and onset of symptoms. It is important to take a history of any previous reactions, and their suspected precipitants in a similar way. Also, a history of any previous exposure to the same potential allergen, and whether or not any symptoms developed is important. It should be noted whether or not related allergens are tolerated. If the suspected allergen is a food, whether the food was raw or cooked may be relevant, as may the circumstances in which the reaction took place (e.g. following exercise).

A common acute presentation is urticaria. Although urticaria is one of the signs of immediate hypersensitivity, this is not the only mechanism. Many viral and other infectious agents are associated with an immune reaction leading to urticaria which is not IgE mediated. Children developing such rashes are often diagnosed with "allergy". In general, if a child wakes up in the morning in his usual environment with an urticarial rash which lasts for a number of days, and does not resolve with antihistamine, the rash is not due to immediate hypersensitivity, and a "trawl" for possible precipitants is unlikely to be helpful.

In children suspected of allergic rhinitis or asthma, a history of nasal and respiratory symptoms should be taken. These include itching, sneezing, rhinorrhoea, nasal congestion, worsening of symptoms is the first thing in the morning after exposure to allergen the night before, cough, (including nocturnal cough), sleep disturbance, mouth breathing and snoring. Any seasonal variation should be noted.

A past history of any other atopic conditions, e.g. eczema, asthma, rhinitis should be taken. In particular, if the child has asthma, it is important to assess how well controlled the asthma is, in terms of frequency and severity of symptoms, precipitants of symptoms, and what prophylactic and rescue medication the child is using. Any current medication should be noted, together with details of any adverse reactions to medications in the past. A picture should be built up of the child's home environment, or any other place where they regularly spend time, including pets, other animal or bird exposure, dust, mould, vegetation, etc.

### Examination

A full general examination may reveal the skin features of eczema. Those with allergic rhinitis may be obvious mouth-breathers with dark rings round the eyes due to suborbital oedema. They can also develop an "allergic crease" across the nose just above the tip, formed after constant rubbing, redness around the eyes, again due to rubbing, and excoriation above the upper lip, caused by nasal drip.

Those with asthma may show signs of chronic chest deformity with increased anteroposterior diameter of the chest, and splaying of the lower ribs (Harrison's sulcus). There may be signs of hyperinflation or wheeze on auscultation.

### Investigations

#### *Investigation of Acute Anaphylaxis*

For children who present with severe symptoms, it can be difficult to establish clinically whether this is a type I reaction, or whether the reaction is anaphylactoid. True

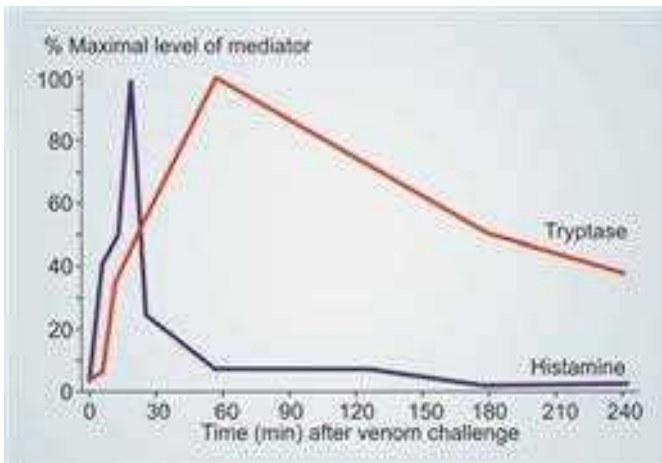


Fig. 24.8: Half-life of mast cell tryptase

anaphylactic reactions are associated with histamine release, which therefore could be measured. However, the rise and fall in histamine levels following an anaphylactic reaction is very steep and short-lived, and therefore likely to escape detection by the time the child presents.

True anaphylactic reactions are caused by mast cell degranulation. While it is histamine which is the major mediator of the resulting symptoms, other chemicals, such as tryptase are also released. The half-life of mast cell tryptase in the circulation is considerably longer than histamine (Fig. 24.8). Serial measurements can therefore be taken over the first 12 hours after the reaction, a rise and subsequent fall to baseline being indicative of true anaphylaxis. If no such change is demonstrated, an alternative mechanism for the symptoms should be sought, and further investigation to identify a particular allergen is likely to be fruitless.

### Skin Prick Testing

This is a quick method of diagnosing immediate hypersensitivity. A drop of a standard solution containing the allergen is put on the skin. The most common sites used are the forearm in older children, and the back in younger children, avoiding skin affected by eczema. A calibrated lancet is used to prick the epidermis to a depth of a couple of millimetres only. Excess solution is removed, and after 15–20 minutes, any resulting wheal is measured, and compared with a positive and negative control. A positive test should have a wheal at least 3 mm greater than the negative control or equivalent to the positive control. For some foods, such as fruits, the fruit itself can be pricked, and then the skin pricked in a similar way (“prick test”). False-negatives can occur if the child has recently taken an antihistamine. While it is extremely rare for a systemic reaction to occur as a result of this degree of allergen exposure, these test should always be performed where staff are trained in the management of

anaphylaxis and appropriate equipment for resuscitation is available.

### Serological Testing

Titres of specific IgE directed against a wide variety of allergens can be assayed in the blood using “RAST” or similar techniques. Such tests are more invasive, and often more traumatic for children, but can be performed in settings where no trained staff are available, and the results are not influenced by antihistamine usage. The concentration of specific IgE with a high positive predictive value for clinical hypersensitivity varies between different allergens. For example a titre of 14 kU/L has a 95% positive predictive value for peanut allergy. Care should be taken not to over-interpret results reported as positive, but with lower titres, as highly atopic children may have detectable specific IgE to many potential allergens which they tolerate with no obvious adverse effects.

### Provocation Test

This is usually performed to investigate food allergy, but can be used for other potential allergens, such as latex or drugs. It can be used when the diagnosis remains uncertain following the other tests detailed above. It is also useful to determine whether a child with a history of allergy has become tolerant (e.g. in milk allergy), or to investigate possible non-IgE mediated or delayed reactions.

In an open challenge, the child is gradually exposed to increasing amount of the allergen until either a reaction occurs, or until they have tolerated an amount as large as a normal exposure would be expected to be. This should only be performed by staff trained in the early recognition and treatment of reactions and where there are facilities for the management of anaphylaxis. In a food challenge, the food is first applied to the skin, then the lips, before small amounts are ingested.

In a double blind placebo controlled challenge the allergen is “hidden” so that the child, the parents and the administering staff are unaware which of two foods/ solutions contains the potential allergen. The procedure for each arm is the same as in the open challenge. A sufficient interval between the two arms is necessary to ensure that any delayed symptoms can be attributed to one arm or the other.

### Patch Testing

This is often confused with skin prick testing, but this technique is used for the diagnosis of delayed (type IV) reactions, particularly involving the skin, such as contact dermatitis due to perfumes, metals and other chemicals. Adhesive patches containing the allergen are applied to the skin (usually on the back) and left in place for 24 hours. Positive and negative

controls are applied to distinguish between true hypersensitivity and irritant reactions. Erythema and induration at the site of contact at 48–72 hours is indicative of sensitivity.

## MANAGEMENT OF ALLERGY

### Management of Anaphylaxis

If a child presents with symptoms which include severe difficulty in breathing or shock, they should be given high flow oxygen via a face mask and epinephrine by intramuscular injection (preferably midpoint in anterolateral thigh) of 1 in 1000 (1 mg/ml) solution. A second dose of epinephrine can be given after 5 minutes if there is no improvement after the first. Antihistamine (e.g. chlorpheniramine) should also be given parenterally. Hydrocortisone is useful in helping to prevent recurrence of reaction, particularly if the precipitating cause has not been completely removed. All children with wheeze as part of the reaction, or who have underlying asthma should also have hydrocortisone to prevent an acute asthma exacerbation. Its effects are not seen for 4–6 hours, however, so it has a limited role in immediate resuscitation. Children with severe shock will benefit from a bolus of intravenous fluid once IV access can be established (the intraosseous route may be used in young children).

It is essential that epinephrine is given by the intramuscular route, the lateral thigh being the most appropriate site. Its mode of action is to stimulate alpha adrenoreceptors, which cause vasoconstriction, thus reducing the excess peripheral blood flow and preventing capillary leak. However, beta receptor stimulation is also required for the bronchodilator effect, and also to stimulate myocardial contractility, and suppress further release of histamine and other mediators. In addition beta 2 receptor stimulation leads to vasodilatation. These receptors are found in muscle, allowing increased blood flow to muscles (for “fight or flight”). This means that epinephrine administered via this route enters the circulation rapidly, enabling its systemic effects. In contrast, subcutaneous tissue only has alpha receptors. The resulting local vasoconstriction inhibits the circulation of epinephrine from the point of injection, limiting its action. It is therefore important to choose a needle of sufficient length to ensure that the muscle is reached.

In profound shock intravenous epinephrine can be given. However, it is potentially very dangerous. A more dilute solution (1:10,000) is used, and it is extremely important that it is given slowly by a doctor experienced in its use.

### Allergen Avoidance

The most important measure in all allergic conditions is to avoid the allergen as far as possible. In food allergic children, they and their parents need detailed information

regarding which foods may contain the allergen, and how to avoid them. If children have multiple food allergies, or are allergic to major sources of essential nutrients, such as milk, it is also important to ensure that their restricted diet is nutritionally replete, and they have access to appropriate substitutes. The input of a paediatric dietician is therefore invaluable.

In children allergic to inhaled allergens, such as animal dander, house dust, etc. total avoidance can be impossible. Measures to reduce exposure can, however, be effective in controlling symptoms. For those allergic to house dust mite, these include using impermeable covers for mattresses and pillows, and washing bed linen frequently in hot water (60°C), removing soft toys, replacing carpet with hard flooring and minimising soft furnishings.

Exposure to pollens can be reduced by shutting windows and doors and limiting outdoor activities on days with high pollen counts. If the child is allergic to animal dander, if possible the pet should be removed. If this is not feasible, then dogs and cats should be washed frequently (which may not be popular with the animal!) and it should not be allowed in the child's bedroom. The animal should be kept outside as much as possible. Hands should be washed immediately if the pet is handled.

### Antihistamines

For conditions where the allergen cannot be completely avoided, such as seasonal rhinitis and conjunctivitis (hay fever), regular long-acting antihistamines such as cetirizine and loratidine can be used. These are less sedative than first generation antihistamines, and so have less effect on cognition, which is important particularly for school aged children who need to use these on a long-term basis.

For conditions where the allergen can usually be avoided, but accidental exposure can occur, such as food allergy, it is important to have antihistamine, such as chlorpheniramine immediately available, so that it can be given at the first hint of symptoms of immediate hypersensitivity. This means in practice that children or their carers should carry the medication at all times. It should also be available in schools and other settings where the child spends time, where those responsible for the child's care should be trained to recognise and treat the signs of a reaction.

## PROPHYLACTIC MEDICATIONS

### Cromoglycate

Cromoglycate is a mast cell stabiliser which also has other anti-inflammatory properties. It is no longer as widely used for the prophylaxis of asthma, as it has limited efficacy compared with inhaled corticosteroids. For those who can



tolerate the irritation on initial application, it is a useful agent in allergic conjunctivitis when used regularly.

### Corticosteroids

Steroids have a broad anti-inflammatory action. As well as reducing inflammation, they decrease vascular permeability, increase the responsiveness of smooth muscle to B agonists, and reduce arachadonic acid metabolite production. Their effects can be seen 4–6 hours after administration, so they are mainly useful in modifying late phase or delayed responses, and resulting chronic inflammation. Used systemically, they prevent late phase response following anaphylaxis, particularly where wheeze is part of the presentation. They are also used in the treatment of acute exacerbations of asthma, and occasionally in severe allergic rhinitis or dermatitis. The disadvantages of systemic use are the unwanted side effects, such as growth retardation, immunosuppression and adrenal suppression.

Topical steroids are the mainstay of management of chronic allergic conditions such as asthma (inhaled), rhinitis (nasal spray) and eczema (topical creams). Given in sufficiently high doses they can have the same side effects as systemic steroids, but even in lower doses may predispose to local infection, such as candidiasis and herpes simplex, and impair wound healing.

### Leukotriene Antagonists

These agents have a more specific anti-inflammatory action than corticosteroids, and also directly inhibit bronchoconstriction. They reduce bronchial responsiveness in both immediate and delayed reactions, including drug and exercise induced symptoms. An example is montelukast, which has been used as a single agent for prophylaxis of asthma, but is recommended as second line treatment for asthma in those not well controlled on moderate doses of inhaled steroids. Montelukast is also effective in the treatment of allergic rhinitis, by causing mucosal vasoconstriction, and reducing oedema and mucous production. It has fewer side effects than steroids, but is not as effective in all patients.

### Injectable Epinephrine

Epinephrine auto-injectors, such as the Epipen or Anapen are now available. They can be carried by children (or their carers) who are at significant risk of anaphylaxis following accidental exposure to an allergen to which they are sensitised. These may include bee or wasp venom, latex or food allergens such as peanut. They administer a single dose, which delivers 0.15 mg, or 0.3 mg epinephrine, the “pen” used being determined by the weight of the child (15–30 kg, or > 30 kg respectively). They are designed for use in the

emergency situation, to “buy time” until medical help can be obtained, rather than to be a substitute for it.

### Who should Carry Epinephrine?

The answer to this question involves a risk assessment for the individual child. Factors to be taken account include the following:

- Risk of inadvertent exposure to the allergen, despite reasonable precautions being taken to avoid it
- Severity of reaction after previous exposure: The child with a history of previous anaphylaxis after minimal exposure would be considered at high risk compared with a child who developed localised symptoms only
- Concomitant asthma: Those with severe or poorly controlled asthma are at greater risk of developing severe breathing difficulties following allergen exposure
- Lifestyle where co-factors may increase the risk, e.g. competitive aerobic sport
- Adolescence: Risk taking behaviour and use of alcohol or other drugs which may impair judgement
- Proximity to back-up medical help. Those in remote areas need to “buy more time”
- Parental anxiety.

Those for whom an auto-injector is prescribed must undertake to carry both antihistamine and epinephrine at all times, and all carers must be trained in the management of reactions, and in the technique for use of the auto-injector. As it will be used only rarely, if ever, regular updates need to be given to maintain proficiency. The training is required not only for parents, but day care, nursery or school staff, and any adult who undertakes the supervision of the allergic child. This may mean that the child’s life is restricted as some people may be unwilling to undertake this responsibility, and therefore the child may be excluded from certain activities. For these reasons it is important that the advantages and disadvantages of such medication should be carefully weighed up before it is prescribed.

### Immunotherapy

The aim of specific immunotherapy is to modify the immune response following allergen exposure. The mechanism by which this is achieved is known as immune deviation. Therapy leads to the reduction of activity of the allergen specific Th2 cells, which mediate allergic inflammation, and producing alternative responses, including the up-regulation of Th1 responses, and the production of interferon gamma, and the induction of regulatory T cells, which produce IL10. At one time it was thought that blocking IgG antibodies had a major role in this process, but it is now thought that the cellular mechanisms are more important.

Traditional specific immunotherapy involves the subcutaneous injection of allergen once or twice weekly, starting with a dose below that required to cause a reaction, and gradually building up until a maintenance dose is achieved, which is greater than that likely to be encountered by natural exposure. This can take a considerable amount of time, and even when the maintenance dose is achieved, periodic injections need to be continued for 2–3 years. There is a risk of both local and systemic reaction, and rarely anaphylaxis, and so immunotherapy should only be performed in a setting where staff is trained to deal with anaphylaxis, and resuscitation facilities are readily available. It also entails multiple injections, which limits its tolerability, particularly in young children, and so this restricts its use in this age group.

This form of immunotherapy has been shown to be effective in allergy to bee and wasp venom, and also in allergies to inhaled allergens, such as tree and grass pollen, and animal dander, such as cat. The benefits can last for many years after discontinuation of treatment. There is some evidence that early treatment can prevent further sensitisation to other allergens. Therapy in children with allergic rhinitis can also prevent the subsequent development of asthma. It would appear that it is less effective in children who are allergic to multiple allergens at presentation. It has been tried in food allergies, such as peanut allergy, but the problem is finding a small enough starting dose to which the child does not react. There have been attempts made to modify the peanut protein in order to reduce the undesirable IgE mediated response, while still inducing the immune deviation. So far, there has been limited success with these attempts.

Because of the difficulties inherent in repeated injections, alternative routes have been tried. The most successful of these has been sublingual immunotherapy. The allergen is placed under the tongue, and subsequently swallowed. Although some patients do describe itching of the mouth and tongue, and sometimes abdominal pain after swallowing the allergen, systemic effects are rare. Preparations are available for use via this route for inhaled allergens such as pollens.

Studies suggest that the beneficial effect may be long-lasting as is the case for subcutaneous therapy, and that there may be a similar effect on the subsequent development of asthma.

## FUTURE DEVELOPMENTS

### DNA Vaccines

An alternative approach to injecting allergen is to give the cDNA of allergens directly. This approach has been used to develop vaccines against infectious diseases and cancer. It has been shown that if a plasmid containing sequences encoding for the allergen, a specific immune response involving Th1 and CD8 cells can be induced. Potentially this would mean that a short course of only one or two doses would be needed to produce the desired clinical outcome.

### Anti-IgE

Humanised monoclonal antibodies have been produced, which bind to the high affinity binding site on the IgE molecule. Trials have been performed with such products in asthma, and also in peanut allergy. In asthma, a beneficial effect on symptoms and also on the requirement for corticosteroids was seen. The role of this mode of therapy in asthma management is not yet clear.

In peanut allergy, treated patients could tolerate a much larger amount of peanut protein before reacting than they were previously able to do. While this is certainly not a “cure” as the effect only lasts while the passive antibody remains in the circulation, such treatment may allow the administration of allergen and escalation of therapy in conventional immunotherapy in children who would previously not have been able to tolerate sufficient exposure.

At the present time we have little influence over the underlying disease process, and concentrate mainly on avoidance of the precipitating allergen, and treating symptoms which arise. We would hope that in the future, research in this field may lead to developments which enable us to offer our patients a true cure, or preferably better strategies for prevention of atopic disease.

# Immunisation Against Infectious Diseases

## IMMUNISATION

Immunisation is one of the most important weapons for protecting individuals and the community from serious diseases.

Immunity to an infectious disease can be acquired through a natural process, e.g. active clinical infection by a microorganism or a subclinical inapparent infection. Immunisation is a process of inducing immunity against an infectious agent, and is generally used in reference to the artificial means of inducing immunity by giving vaccines, i.e. vaccination. Immunisation can also be achieved by a passive process wherein antibodies to the infectious agent produced by another individual or animal who has been exposed to it, are extracted, and are used to provide protection. These antibodies provide protection for a short duration as their level decreases over a period of time leading to waning of immunity. Also, the level of protection provided by such methods is not as good as by the individual's own response. The examples of passive immunisation are:

1. Immunoglobulin from human source
  - General non-specific pooled immunoglobulin, e.g. intravenous immunoglobulin.
  - Specific antibodies against an infectious agent, e.g. antirabies or antitetanus globulins.
  - Transplacental transfer from mother to foetus of various immune globulins.
2. From animal sources
  - Pooled sera, e.g. anti-diphtheritic serum (ADS—diphtheria antitoxin).

## Various Types of Vaccines Used for Active Immunisation

### *Killed Vaccines*

The whole infectious agent is killed artificially, and made into a suitable vaccine, e.g. whole cell pertussis vaccine, cholera vaccine.

### *Live Attenuated Vaccines*

In this type of vaccine, the microorganisms are subjected to processes which attenuate their disease causing capabilities while retaining the immunity generating components. After administration, the microorganisms multiply in the recipient, and thus generate an immune response similar to a natural infection, e.g. BCG, measles vaccine.

### *Toxoids*

Toxoids are detoxified toxins with the capacity to stimulate formation of antitoxin in the recipient, e.g. tetanus toxoid, diphtheria toxoid.

### *Sub-unit Vaccines*

A part of the microorganism, which has the capability to generate the immune response, is utilised for making the vaccine, e.g. acellular pertussis, Vi antigen typhoid vaccine.

### *Recombinant Vaccines*

The recombinant vaccines are synthesised using a nonpathogenic organism carrying immunogenic components of the pathogenic organism, e.g. Hepatitis B vaccine. These can be *Live Attenuated Vector Vaccines* which involve incorporation of a pathogen's antigenic peptides into a harmless carrier virus or bacteria, or chimeric vaccines where genes from the target pathogen are substituted for similar genes in a safe but closely related organism. In DNA vaccines, a DNA plasmid encodes a viral gene that can be expressed inside cells of the animal to be immunised.

## Mechanism of Immune Response

Lymphocytes play a vital role in generating the immune response following exposure to an antigen which may be either a microorganism or an exotoxin. For the immune response both types of lymphocytes, i.e. B and T lymphocytes, may

be activated and only the B cells may be involved. When the immune response is generated through B lymphocytes only and it is termed as T cell independent and when both B and T cells are involved, it is termed T cell dependent. Majority of the antigens, however, require both B and T cells to generate antibody production, and are hence T cell dependent. In children below 2 years of age, T independent response is poorly initiated.

After introduction of the antigen into the body, T-helper cells (CD4) are activated following which, a cascade of mediators is triggered. After the first exposure to the antigen, as in a primary vaccination, there is a latent period of 7–10 days followed by detectable antibodies in the serum, usually after about 2 weeks. Initially, it is mainly IgM antibodies followed by IgG. IgG antibodies are produced in peak concentration after about 2–6 weeks, and are the most critical for protection against infection. Repeat exposure to the same antigen, as in booster vaccination, leads to humoral or cell mediated response rapidly within the first week.

The vaccines given orally are usually live attenuated, and hence after ingestion the infecting agent multiply in the intestinal mucosa. This induces an IgA response locally. After multiplication in the mucosa, the microorganisms invade the body further to generate other antibodies.

## Factors Affecting Immune Response

### Host Factors

**Age:** Age is one of the critical factors to be considered for immunisation. In young infants, presence of placentally transferred maternal antibodies can interfere with the immune response to an antigen, e.g. measles. Also, a relatively immature immune system may not be able to initiate an adequate response to the vaccinated antigen. Another factor is the poor immunogenicity of T cell independent antigens in children less than 2 years of age. Vaccines containing such antigens have to be conjugated with a compound which has the ability to generate T cell response, e.g. HiB conjugate vaccines.

**Nutrition:** Malnutrition of severe degree can decrease the capability of the host to activate the immune system adequately.

**Pre-existing antibodies:** Presence of antibodies to the specific vaccinated antigen may interfere with the immune response, e.g. maternal antibodies.

**Immunocompromised status:** Any condition leading to an immunocompromised state either due to a disease, e.g. malignancy or due to treatment, e.g. prolonged steroid use can impair the immune response to a vaccine.

### Key Learning Point

- Live vaccines should not be given to children with impaired immune response, whether caused by disease or treatment with high doses of corticosteroids or other immunosuppressive drugs. In fact, live vaccines should be postponed until at least 3 months after stopping corticosteroids or other immunosuppressive drugs, and 6 months after stopping chemotherapy or generalised radiotherapy.

## Vaccine Related Factors

### Type of Vaccine

Live vaccines are much more likely to induce an immune response similar to a natural infection, and confer longer period of immunity.

### Route of Administration

The optimal route of administration as specified for a particular vaccine should be used. Alternative routes may not be equally effective. Orally administered vaccines lead to a secretory IgA response in gut mucosa, which cannot be induced by parenteral vaccine, e.g. oral polio vaccine.

### Storage Conditions

Appropriate temperature and other storage conditions are an absolute essential requirement to maintain potency of the vaccine. Cold chain, i.e. maintaining the required temperature from the manufacturer to the recipient, is an essential pre-requisite for effective vaccination.

### Adjuvants

Adjuvants are substances that boost the immunogenicity of vaccines. They improve the potency of the immune response and enhance immunological memory. They also allow antigen sparing and help in reducing the doses. They act as immunostimulators or immunopotentiators. Aluminium containing compounds have been one of the most frequently used adjuvant.

### Key Learning Point

- The intramuscular route should not be used in children with bleeding disorders such as haemophilia or thrombocytopenia. Instead, they may be given vaccines by subcutaneous injection.

## ADVERSE EVENTS

The present day vaccines, which have been approved for use in children, are expected to be safe. Sometimes, they

**Table 25.1:** Common adverse events of vaccines

<i>Fever of short duration</i>	<i>Shock like state</i>
<ul style="list-style-type: none"> <li>• DPT</li> <li>• Measles</li> <li>• Typhoid</li> <li>• T. toxoid</li> </ul>	<ul style="list-style-type: none"> <li>• DPT</li> <li>• Measles (contaminated)</li> </ul>
<i>Local reaction</i>	<i>Rare events</i>
<ul style="list-style-type: none"> <li>• DPT</li> <li>• Typhoid</li> <li>• T. toxoid</li> </ul>	<ul style="list-style-type: none"> <li>• Seizure DPT</li> <li>• Paralysis OPV</li> <li>• Anaphylaxis measles</li> <li>• Guillian Barre T. toxoid</li> <li>• Inconsolable crying DPT</li> </ul>
<i>Transient rash</i>	
<ul style="list-style-type: none"> <li>• Measles</li> <li>• Varicella</li> </ul>	

can cause certain mild adverse reactions and rarely serious events. Various components of the vaccine can lead to an allergic reaction, e.g. the microorganism, antibiotics or other stabilising agents used in the vaccine. The usual adverse events and the causative vaccines are shown in Table 25.1.

### Contraindications

Every child has a right for immunisation, and withholding it for some common minor illness or for any other reason is not justifiable. There are few contraindications to vaccination, and one must apply them judiciously so as not to have a missed opportunity for immunisation in a child.

- Severe acute illness—infectious or noninfectious
- Immunocompromised states, especially for live vaccines
- History of allergic reaction to vaccine
- Egg allergy in case of egg/chicken protein containing vaccines
- History of previous severe reaction to DPT

**Box 25.1:** Post-immunisation pyrexia in infants

The parent(s) should be advised that if pyrexia develops after childhood immunisation, the infant can be given a dose of paracetamol and if necessary, a second dose given 6 hours later; ibuprofen may be used if paracetamol is unsuitable. For post-immunisation pyrexia in an infant aged 2–3 months, the dose of paracetamol is 60 mg; the dose of ibuprofen is 50 mg.

### Less Frequently Used Vaccines

#### *Pneumococcal Vaccine*

*Pneumococci* cause significant morbidity of upper as well as lower respiratory tract, as well as invasive disease, especially in children below 2 years of age. A polyvalent polysaccharide pneumococcal vaccine is available which has poor immunogenicity in children less than 2 years old, as it is T-cell independent. A conjugate vaccine is also available which is effective in the target population of less than 2 years of age, and covers 13 strains of pneumococci. It can

be given along with the DPT vaccine during infancy with a booster in the second year of life. The pneumococcal vaccines are specially indicated in splenectomised or likely to undergo splenectomy or those with chronic diseases or are immunocompromised.

The vaccine is given in dose of 0.5 ml intramuscularly with revaccination after 3–5 years for polyvalent vaccine.

#### *Meningococcal Vaccine*

*Meningococci* are capable of causing epidemics of meningitis or severe meningococemia. In view of these, the vaccine is indicated for contacts of the patient or in outbreak situations. There are mainly five disease causing sero groups, namely A, B, C, Y, W135. As immunity is specific for sero groups, the vaccine use is dictated by the isolation of a particular serotype during outbreaks/epidemics. Meningococcal vaccine is also indicated for immunocompromised children. Unconjugated bivalent (A + C) vaccine is more freely available as compared to conjugated quadrivalent (A, C, Y and W135) which is also more expensive.

#### *Influenza Vaccine*

Influenza viral disease is a frequent respiratory morbidity which can become serious in certain patients. *Influenza virus* is characterised by frequent mutations, antigenic drifts and shifts. The immunity for the various strains is specific, and hence to be effective, the vaccine has to incorporate the prevalent antigenic strain. For this vaccine, WHO reviews and recommends the inclusion of prevalent strains annually. The vaccine is given intramuscularly/subcutaneously to children at high risk of flu related morbidity, e.g. those with chronic lung/heart disease or immunocompromised. Recently, variants of the influenza virus such as Swine flu and Bird flu have been responsible for significant morbidity and also mortality. The vaccine against Swine flu has become available as an independent vaccine as well as in combination with seasonal flu vaccine.

**Box 25.2:** Vaccines and asplenia

The following vaccines are recommended for asplenic children or those with splenic dysfunction.

- *Haemophilus influenzae* type b (Hib) vaccine
- Meningococcal group conjugate vaccine
- Pneumococcal polysaccharide vaccine
- Influenza vaccine

#### *Rabies Vaccine*

Rabies caused by a bite/lick/scratch of a rabid animal, is a fatal disease. The vaccine is usually used as a postexposure prophylaxis, but can be given for routine immunisation for those at higher risk, e.g. handling susceptible animals (veterinarians, wild life workers, etc.). The older nerve

tissue vaccine is no longer recommended or used. The tissue culture vaccines can be: (A) chick embryo cell; (B) human diploid cell; (C) duck embryo cell and (D) vero cell vaccine. All have almost equal efficacy. For post-exposure prophylaxis, as per WHO guidelines, the vaccine is given on day 0, 3, 7, 10, 14 and 28.

### *Inactivated Polio Vaccine*

Inactivated Polio Vaccine (IPV) contains killed virus of all three serotypes. It is an effective vaccine with good safety profile, and can be combined with other vaccine like DPT and HIB. IPV is currently recommended as an additional vaccine along with oral polio in the fight to eradicate polio.

### *Rota Virus Vaccine*

Rota virus is responsible for a significant proportion of infantile diarrhoeas. An oral live attenuated vaccine is available against this virus, and is given in two doses in early infancy.

## Newer Vaccines

### *Japanese Encephalitis*

Viral encephalitis caused by Japanese B virus is endemic in some parts of India (Uttar Pradesh, Andhra Pradesh). As there is no specific treatment, and it is associated with high mortality and morbidity, there is a definite indication for this vaccine. Presently, there are three types of vaccines for Japanese encephalitis—two inactivated and one live attenuated and better ones are in investigational stage.

### *Acellular Pertussis (DPaT)*

Acellular pertussis vaccine has been synthesised to decrease the reactogenicity of the whole cell vaccine. In these, components of the pertussis bacillus with good immunogenic properties have been incorporated instead of the whole killed bacillus. It is almost equally effective, marginally less reactogenic but more expensive.

### *Human Papilloma Virus Vaccine (HPV)*

Human papilloma virus is an important aetiological agent for cervical cancer in women, and has also been implicated in other anogenital cancers. In addition, it also causes genital warts. The vaccine against HPV is now available, recommended for adolescents and women up to 35 years of age.

## Some Important Vaccines under Investigation

Shigella vaccine	Dengue Virus
Cholera vaccine	RSV
Streptococcal vaccine (rheumatic fever)	HIV
Malaria vaccine	Hepatitis C

## Some Important Issues

- Simultaneous multiple vaccines are sometimes required for a child with incomplete schedule and poor compliance. Most of the vaccines can be given without the risk of losing efficacy or compromising safety.
- Delayed doses of a particular vaccine do not necessarily indicate restarting the series, but number of scheduled doses must be completed.
- Interval between vaccines is an important issue for most live vaccines as they invade the host, and multiply in the body to generate the immune response. Either the live vaccines should be administered together or 4 weeks apart.
- Combination vaccines: They may combine different strains of same microorganism, e.g. polio vaccine, pneumococcal vaccine, or different disease causing agents, e.g. DPT, MMR (different type of vaccines or same type). Avoid multiple injections, especially when behind schedule
  - Improve timely vaccination coverage
  - Reducing the cost of stocking and administering separate vaccines
  - Reducing the cost for extra healthcare visits
  - Facilitating the addition of new vaccines into immunisation programmes.

## International Immunisation Endeavours

Immunisation has been one of the most cost effective public health strategies the world over. Immunisation alone has saved many more lives than any other preventive strategy. Small pox has been eradicated from the world; poliomyelitis is in the process of being eradicated, and many other diseases like measles, tetanus, and diphtheria have been hit.

At the international level, immunisation has been a key strategy for all health organisations. The first organised programme launched by World Health Organisation (WHO) was the Expanded Programme of Immunisation (EPI) in 1974. EPI covered children less than 5 years of age for the vaccines, viz. BCG, DPT, OPV, Measles and TT. In India, typhoid was included. As this did not meet the desired goals, it was changed to Universal Immunisation Programme (UIP) which targeted children less than 1 year of age along with infrastructural issues like vaccine production, cold chain system and monitoring.

Globally, many international agencies (WHO, UNICEF, World Bank, Rockefeller foundation) launched the childhood vaccine initiative (CVI) in 1991. This was further consolidated into a Global Alliance for Vaccine and Immunisation (GAVI) in year 2000, which has partnerships of private as well as public organisations.

The immunisation schedule is shown in Table 25.2.

Table 25.2: Immunisation schedule

Vaccine name	Type	Contents	Route	Dose	Efficacy	Storage Temperature	Age of administration
BCG (Bacillus Calmette Guérin)	Live attenuated, freeze dried, bovine strain	0.1–0.4 million bacilli/dose	ID	0.1 ml	0–80%	2–8°C	Birth
Polio vaccine	Live attenuated	Trivalent I 106 TCID 50	O	2 drops	80–90%	=<-20°C	5 doses in first year starting at 0 month and then at 4–8 week interval; Boosters with DPT
Oral (Sabin)		II 105 TCID 50 III 105.8 TCID 50					
Injectable (Salk)	Killed	I 40D II 8D III 32D	IM	0.5 ml	>95%		
DPT as Diphtheria toxoid	Toxoid	20–30 I <sub>f</sub>	IM	0.5 ml	95%	2–8°C	3 doses in first year starting at 6–8 week and then 4–8 weeks apart; Boosters at 18 months and 5 year
Pertussis	Killed	20 million bacilli 5–10 I <sub>f</sub>	"	"	85%		
Tetanus	Toxoid			"	100%		
Hepatitis B	Recombinant subunit	10 mcg (up to 19 years.) 20 mg (>19 years)	IM	0.5 ml	94%	2–8°C	0, 1, 6 months
HiB	Conjugate capsular	10 mcg	IM	0.5 ml	97%	2–8°C	Same as DPT; only 1 booster at 18 months
<i>H. influenzae B</i>	polysaccharide vaccine						
Measles	Live attenuated	1000TCID <sub>50</sub>	SC	0.5 ml	95%	2–8°C	6–9 months
MMR (Measles)	Live attenuated		SC	0.5 ml	95%	2–8°C	At 15 months age
Mumps		1000TCID <sub>50</sub>					
Rubella		5000TCID <sub>50</sub> 1000TCID <sub>50</sub>					
Typhoid	Capsular polysaccharide						After 2 years age; booster every 2–3 years
Vi antigen	Subunit	25–30 mcg	SC, IM	0.5 ml	70%	2–8°C	Above 6 years age; booster every 3 years
Oral typhoid vaccine							
Ty21a	Live attenuated		O	3 Capsules	70%	2–8°C	
Chickenpox	Live attenuated	103.3PFU	SC	0.5 ml	95–100%	2–8°C	1–13 years age; single dose, >13 years age; 2 doses 1 month apart
Hepatitis A	Live attenuated	720 ELU (up to 19 years)	IM	0.5 ml	90–100%	2–8°C	2 doses; 6 months apart

**Box 25.3: Prematurity**

- Children born prematurely should receive all routine immunisations based on the actual date of birth.
- There is no evidence of adverse reactions from vaccines.

## TRAVEL IMMUNISATION

In these days of international travel, it is essential that a child should be particularly immunised against those diseases which he may be exposed to in the country of his visit. This will be in addition to the routine childhood immunisations being up to date. There are countries in the world where no special immunisation is required for travellers such as the United States, Europe, Australia or New Zealand, although, all travellers should have immunity to tetanus and poliomyelitis. But, certain precautions are required in Non-European areas surrounding the Mediterranean, in Africa, the Middle East, Asia and South America. Many countries require an international certificate of vaccination from individuals arriving from, or who have been travelling through endemic areas whilst other countries require a certificate from all entering travellers.

Long-term travellers to areas that have a high incidence of poliomyelitis or tuberculosis should be immunised with the appropriate vaccine. Protection against hepatitis A is recommended for travellers to high-risk areas outside Northern and Western Europe, North America, Japan, Australia and New Zealand. Hepatitis A vaccine is preferred, and it is likely to be effective even if given shortly before departure; normal immunoglobulin is no longer given routinely, but may be indicated in the immunocompromised.

Hepatitis B vaccine is recommended for those travelling to areas of high prevalence, and plan to stay there for long periods. Short-term tourists are not generally at increased risk of infection. Prophylactic immunisation against rabies is recommended for travellers to enzootic areas on long journeys, or to areas out of reach of immediate medical attention.

Typhoid vaccine is indicated for travellers to those countries where typhoid is endemic. There is no requirement for cholera vaccination as a condition for entry into any country, but oral cholera vaccine may be considered for those travelling to situations where the risk is greatest. Yellow fever immunisation is recommended for travel to the endemic zones of Africa and South America.

Immunisation against meningococcal meningitis is recommended for children travelling to countries of risk. They should be immunised with a meningococcal polysaccharide vaccine that covers serotypes A, C, W135 and Y. Vaccination is especially important for those living with local people, or visiting an area of risk during outbreaks.

Malaria chemoprophylaxis should generally be started 1 week before travel into an endemic area, and should be continued for 4 weeks after leaving. It is important to be aware that any illness that occurs within 1 year and especially within 3 months of return might be malaria even if all recommended precautions against malaria were taken.

### Key Learning Point

- ➔ Those children who cannot receive live vaccines, the use of normal immunoglobulin should be considered after exposure to measles and varicella-zoster immunoglobulin after exposure to chickenpox or herpes zoster.



# Infectious Diseases

## DIPHTHERIA

### Aetiology

Diphtheria is caused by *Corynebacterium diphtheriae* also known as Klebs-Löffler bacillus. *C. diphtheriae* is an aerobic, polymorphic, gram-positive bacillus. The disease causing potential is in the exotoxin produced by the bacillus. Three biotypes of the bacillus namely *mitis*, *intermedius* and *gravis* have been differentiated with varying disease causing capabilities.

### Epidemiology

*C. diphtheriae* resides mainly on human mucous membranes and skin although it can be viable in dust or on fomites for about six months. The disease is transmitted from man to man, either through carriers or patients. It spreads primarily by airborne droplets or direct contact with respiratory secretions. The most susceptible age group is unimmunised children below 15 years but can occur in unprotected adults also. Asymptomatic carriers are an important source of infection.

### Pathogenesis

After infection, *C. diphtheriae* remains in the respiratory mucosa. They induce a local inflammatory reaction and elaborate an exotoxin, which is responsible for the virulence of the disease. Locally, there is necrosis of the mucous membrane along with collection of fibrin, leucocytes and RBCs. Together they form the characteristic dirty grey coloured membrane seen in the upper airways of a patient with diphtheria. Attempts to remove this thick adherent membrane lead to bleeding, as superficial epithelium is part of the membrane. The membrane can cause life-threatening obstructive respiratory symptoms by blocking the air passages from pharynx to larynx and even trachea. The

toxin affecting the nervous tissues, cardiac muscles, renal tubules and platelets causes the other serious manifestations.

### Clinical Features

The usual incubation period of diphtheria is 2–5 days. The major symptoms and signs are related to the respiratory tract but other parts of the body can also be affected viz. skin (Cutaneous diphtheria) ears, eyes or genital tract. The presentation due to the local involvement varies according to the site whereas the features due to exotoxin occur irrespective of the site. The commonest site of involvement is tonsillopharyngeal area followed by nose and larynx.

#### Nasal

Frequently resembles common cold. It is seen more often in infants. There is serosanguineous nasal discharge which maybe unilateral with mild constitutional symptoms. Often there is a membrane seen on the nasal septum.

#### Tonsillopharyngeal

The typical membrane is the hallmark of the disease. This can have a variable extent from unilateral to bilateral involving all the pharyngeal structures and can lead to respiratory obstruction. Accompanying symptoms maybe mild initially but toxemia can set in early. The surrounding soft tissue and the draining lymph nodes can enlarge and give the appearance of 'Bull-Neck'.

#### Laryngeal

The membrane can extend from pharynx to larynx causing severe respiratory obstruction or difficult, noisy breathing with hoarse voice and stridor. From larynx the membrane can further extend to trachea and the respiratory symptoms can become more severe.

## Differential Diagnosis

1. Streptococcal membranous pharyngitis
2. Vincent's angina
3. Viral laryngotracheobronchitis.

## Complications

Most of the complications are caused by the exotoxin.

### Toxic Myocarditis

It occurs in 10–25% of patients and is responsible for almost half the deaths due to diphtheria. Typically it is seen during second to third week but can occur as early as first week and as late as sixth week. Tachycardia with soft heart sounds, heart failure or sudden respiratory distress may indicate the onset. Cardiac dysrhythmias may also occur.

### Toxic Neuropathy

Diphtheria toxin can lead to a variety of neurological involvements in a multiphasic manner. The different manifestations are shown in Table 26.1. The recovery from most of these is likely although residual weakness may sometimes persist.

## Diagnosis

The diagnostic investigation for diphtheria is the demonstration of *C. diphtheriae* either by smear examination or by culture. For this purpose a swab should be taken from under the edges of the membrane or the membrane itself. The smear is preferably stained by Albert stain. A negative smear is not reliable and culturing the organism is necessary. For culture, selective media, potassium tellurite, should be used.

**Table 26.1:** Neurological complications of diphtheria

Site of involvement	Time of onset	Clinical presentation
a. Palatal paralysis	2–3 weeks	Weakness of pharyngeal muscles, hoarse voice, nasal twang, swallowing difficulty, aspiration.
b. Ocular paralysis (Oculomotor ciliary paralysis)	3–5 weeks	Strabismus, blurred vision, accommodation paralysis
c. Polyneuropathy (Symmetric)	2 weeks to 3 months	Proximal muscle weakness, motor deficits with decreased deep tendon reflexes
d. Phrenic nerve paralysis	2 weeks to 3 months	Diaphragmatic paralysis
e. Vasomotor Centre	2–3 weeks	Hypotension, cardiac failure.

## Treatment

Treatment for diphtheria consists of:

- Neutralization of toxin
- Eradication of *C. diphtheriae*
- Supportive therapy.

### Neutralization of Toxin

For this anti-diphtheritic serum (ADS) should be given at the earliest possible. ADS is given after intradermal sensitivity testing by IM or IV route. The dose depends on the site of involvement.

Nasal Diphtheria	20,000 units
Tonsillar/Pharyngeal	40,000–80,000 units
Laryngeal	80,000–1,20,000 units

Diphtheria immune globulin (human) if available can also be used in the dose of 0.6 ml/kg.

### Eradication of *C. diphtheriae*

It is equally important to stop further production of toxin by eliminating the organism. The antibiotic of choice is Penicillin or Erythromycin. IV crystalline penicillin 1 lac units (=100,000 units)/kg per day in 6 hourly doses is given for 10–14 days. The dose of erythromycin is 40–50 mg/kg per day in 4 divided doses orally for the same duration. Elimination of *C. diphtheriae* is documented by two successive cultures from the site after stopping antibiotics.

### Supportive Therapy

Isolation of the patient is required to prevent cross infection. Bed rest is mandatory for first 2 weeks and even later in case of cardiac complications followed by graded return of activity. Respiratory obstruction is a frequent occurrence hence careful watch needs to be maintained till the oropharyngeal inflammation and membrane disappear. A tracheotomy set and provision for assisted ventilation should be readily available.

The case fatality rate of 10% is reported from even good centres. The usual cause of death is either respiratory obstruction or myocarditis. After recovery from diphtheria, the child needs to be vaccinated, as the disease does not confer good immunity.

### Contacts and Carriers

All household contacts should be screened with swab cultures and given prophylaxis with either erythromycin for 7 days or a single injection of long acting benzathine penicillin. This should be followed by appropriate vaccination. If cultures come positive, subsequent cultures after prophylactic antibiotic need to be done to document negative culture.

**Case Study**

A 4-year-old boy from poor socio-economic strata was brought to the emergency paediatric service with a history of cough and a low-grade fever for 4 days. He had developed difficulty in breathing over 4 hours prior to hospitalisation. His father did not know the child's immunisation status. On arrival he was dysphonic, pale, malnourished and temperature was 38°C. There was a diffuse swelling of his neck. Throat examination revealed a dirty grey membrane over his tonsils, tonsillar pillars and extending to the soft palate. The membrane could not be removed easily and bled from underneath. Pulse 120/min. He had marked suprasternal and subcostal retractions. Otherwise systemic examination was unremarkable. Throat swab for *C. diphtheriae* was positive. He was given diphtheria antitoxin intravenously 60,000 units after sensitivity testing and benzyl penicillin. He developed sudden onset acute respiratory distress. He underwent tracheotomy to relieve the obstruction caused by the membrane in the upper airways. Thereafter he made an uneventful recovery.

*Diagnosis:* Tonsillar diphtheria.

**Key Learning Points**

- The two usual causes of mortality in diphtheria are upper airways obstruction and myocarditis
- After recovery from diphtheria the patient needs active immunisation with appropriate diphtheria vaccine.

**PERTUSSIS (WHOOPIING COUGH)**

Pertussis means intense cough in Latin. Pertussis is an acute infectious disease of the respiratory tract occurring in susceptible hosts of all ages.

**Aetiology**

The main causative organism for pertussis is *Bordetella pertussis*. Few cases are attributable to other *Bordetella* species like *B. parapertussis* or *B. bronchiseptica*. These organisms are tiny, gram-negative and cocco-bacillary in shape.

**Epidemiology**

Pertussis has been prevalent worldwide for many centuries and has been a leading cause of death in children especially in the pre-vaccination era. Whooping cough may occur at any age, even in the first few weeks of life. Placental transfer of antibody does not protect young infants passively. With effective coverage of pertussis vaccine the incidence of the disease as well as attributable mortality have markedly decreased. The immunity conferred by vaccine as well as the disease wanes over a period of time. Hence older children and adults with poor vaccine updates become susceptible to active disease and/or act as reservoir of infection.

**Pathogenesis**

*Bordetella pertussis* produces a pertussis toxin as well as few other biologically active substances. All together are responsible for various inflammatory changes with pertussis toxin playing a central role. The mucosal lining of the respiratory tract is inflamed with necrosis and desquamation of epithelial cells leading to obstruction, atelectasis and accumulation of secretions. The resultant hypoxia can affect liver and brain also.

**Clinical Features**

The incubation period of 3–12 days is followed by three characteristic stages of pertussis. The first stage, Catarrhal stage begins with low-grade fever, nasal symptoms and conjunctival redness with watering of eyes, just like any other upper respiratory infection. Coughing indicates the beginning of paroxysmal stage, which can last 2–6 weeks. Initially the cough is dry, irritating and hacking and gradually becomes paroxysmal. The paroxysms of cough can soon be accompanied by the characteristic whoop. The whoop is a forceful inspiration through partially closed airways, which follows a bout of coughing. During the paroxysms of cough the child has incessant coughing which increases in crescendo with flushing of face, bulging of eyes and gasps of respiration. During severe bouts of coughing there may be cyanosis also. Very often vomiting follows the bouts of coughing. The infant or young child usually appears quite well in between these paroxysms of coughing although the frequency of such bouts can keep on increasing progressively. Gradually the patient passes into the Convalescent stage where the coughing episodes become less severe and less frequent. The cough can persist for some time and hence the disease has also been called 'Cough of 100 days'. The young infant or a sick child may not have the characteristic whoop, as they cannot generate enough pressures in their respiratory passage.

**Complications**

Respiratory system is the site for most complications especially secondary bacterial infections. Otitis media, emphysema, air leaks in the form of pneumothorax or pneumomediastinum and even subcutaneous emphysema can occur. During the paroxysmal stage, serious CNS complications like seizures and encephalopathy can occur. A number of complications associated with the severe cough or whoop can occur. The raised pressure in various blood vessels can lead to subconjunctival haemorrhage, retinal haemorrhage, epistaxis and even intracranial haemorrhage (Fig. 26.1). Increase in intra-abdominal pressure can cause inguinal hernia, rectal prolapse and rarely diaphragmatic rupture. Due to protracted



**Fig. 26.1:** Subconjunctival haemorrhage and black eye in a child with pertussis

course, vomiting and poor feeding, malnutrition is a frequent occurrence. Flaring of underlying tuberculosis can also occur.

### Differential Diagnosis

- Viral infections, e.g. Adenovirus, Influenza, RSV
- Mycoplasma infection
- Foreign body aspiration
- Endobronchial tuberculosis.

### Diagnosis

Diagnosis is mainly based on the history and clinical examination. None of the investigations are very efficient in diagnosing pertussis. Following investigations maybe helpful:

- Leucocytosis especially increased lymphocytes
- Low ESR
- Isolation of *B. pertussis*
  - Deep nasopharyngeal swab/cough plate cultures
  - Direct fluorescent antibody testing
  - PCR on nasopharyngeal swab
- IV. Serological tests during convalescent stage to detect specific antibodies.

### Treatment

The aims of treatment are:

- Decrease the severity and frequency of cough paroxysms as much as possible: Initially the episodes of cough paroxysms should be observed and an assessment of their severity made. The child should be asked to rest in a quiet, undisturbed environment with minimal essential lighting. A nebulised mist and/or salbutamol can be helpful in some patients. In addition, administration of appropriate antibiotics early in the course of disease can

also decrease the severity. The antibiotic of choice is Erythromycin 40–50 mg/kg per day in 4 divided doses orally for 2 weeks.

- Maintain nutrition: Small, frequent, easily swallowable and calorie dense foodstuffs should be given. Forced feeding should be avoided. Feeds are better given soon after a bout of coughing.
- Identifying the need for assisted/hospitalisation care: A child with pertussis should be managed at home if having infrequent paroxysms and able to feed well. Only in young or sick infants hospitalisation may be required.

All patients need to be isolated till they have received at least 5 days of antibiotics.

### Contacts

All contacts irrespective of symptoms, age, and immunization status should be given antibiotic for 2 weeks. For unimmunised or incompletely immunised contacts, the schedule should be completed. Those who have received a vaccine dose >6 months back should receive a booster.

#### Key Learning Point

- ➔ Diagnosis of pertussis is mainly clinical.

## TETANUS

Tetanus, also known as lock-jaw is an illness caused by *Clostridium tetani*. Despite the availability of safe and effective immunisation, tetanus is still a serious health problem worldwide especially in many developing countries.

### Aetiology

*Clostridium tetani* is a gram positive, anaerobic organism. It forms spores, which are resistant to boiling but are destroyed by autoclaving. *C. tetani* is not an invasive organism. On entering the human body, it elaborates two exotoxins namely tetanospasmin and tetanolysin. Tetanospasmin is responsible for all the manifestations of tetanus. After botulinum toxin, it is the next most poisonous substance known in the world.

### Epidemiology

Tetanus occurs all over the world. The resistant spores of *C. tetani* are ubiquitous in nature and can be present in several dirty objects. They also inhabit the human intestines or animal oral cavity and intestines.

Tetanus occurs in unimmunised adults and children exposed through dirty or contaminated injuries and wounds. The other susceptible group is pregnant women undergoing unsterile methods of delivery. Along with them, the newborns are another major susceptible population. Neonatal

tetanus is reported from many developing countries where unimmunised women give birth in unclean conditions. The umbilical cord is the portal of entry for the neonate born through such a process. Occasionally tetanus occurs with no history of trauma. In such cases chronic supportive otitis media or intestinal colonization with *C. tetani* leads to an invasive infection.

### Pathogenesis

After entering through a portal, the tetanus spores germinate and the vegetative bacterial cell dies releasing the exotoxin. Tetanospasmin binds the neuromuscular junction and then enters the major nerves and travels to the spinal cord. There it blocks the inhibitor pathways of muscular contraction leading to sustained spasm of muscles. The autonomic nervous system is also affected. *C. tetani* by itself causes little local inflammatory reaction.

### Clinical Features

The incubation period of tetanus varies from 3–30 days. The presentation is most often generalized but sometimes can be localized also. The usual early symptoms maybe irritability or headache, which is soon accompanied by the classical presentation of trismus or lockjaw in 50% of cases. These are followed by stiffness of whole body, difficulty in chewing and swallowing and then muscle spasms. The typical Risus sardonicus occurs because of spasm of masseter muscles of face. The stiffness and spasms lead to neck retraction and an extreme opisthotonus position i.e. arching of the back. There can be involvement of laryngeal and respiratory muscles also. With all this, the patient is generally conscious and hence has extreme pain. The spasms can be caused by minor stimuli such as noise, light, touch and even occur spontaneously. The autonomic involvement can cause tachyarrhythmias, hypertension, urinary and bowel involvement. There is accompanying fever of variable level.

#### Neonatal Tetanus (*Tetanus Neonatorum*)

Tetanus in neonates is an important cause of neonatal mortality. As stated earlier, unimmunised mothers undergoing unclean delivery is the cause, the portal of entry being the umbilicus. The first symptom is sudden inability to suck. The infant rapidly develops stiffness of the body, followed by generalised spasms. Persistent Risus sardonicus is common. Spasms of the larynx occur early in the course of neonatal disease and the infant is unable to swallow. Aspiration pneumonia and gastroenteritis are common complications. The differential diagnosis includes intracranial injury secondary to birth trauma, meningitis, hypocalcaemic tetany, sepsis and seizures of any other aetiology (Fig. 26.2).



Fig. 26.2: Marked opisthotonus seen in tetanus neonatorum

### Complications

Respiratory complications occur due to heavy sedation and laryngeal spasms. Cardiac arrhythmias, hypotension are seen in some patients.

Severe spasms can cause rhabdomyolysis, myoglobinuria and fractures.

### Differential Diagnosis

- Abscess in pharyngeal areas can sometimes produce trismus.
- Acute encephalitis
- Rabies
- Strychnine poisoning

### Diagnosis

The diagnosis is based on classical clinical picture. Attempts to isolate *C. tetani* are not successful and not required. The routine laboratory investigations are more helpful for assessing secondary bacterial infections.

### Treatment

Following are the objectives of treatment of tetanus

- Neutralization of toxin
- Control of spasms
- Eradication of *C. tetani*
- Intensive supportive care
- Prevention of recurrence.

#### Neutralization of Toxin

The toxin bound to neural tissue cannot be neutralized. Hence the first priority is to administer antitoxin to render the free available toxin ineffective. For this purpose, animal derived antitoxin Anti-tetanus serum (ATS) as well as human derived tetanus immune globulin (TIG), both, are available. ATS is given in the dose of 50,000–1,00,000 units

after sensitivity testing. It can be given by intravenous or intramuscular route, generally half IV and half IM. It has to be given as a one time dose as repeat doses can cause severe immunological reactions. There is a significant risk of serum sickness with ATS. The dose for TIG ranges from 3000–6000 units, intramuscular.

### Control of Spasms

Spasms and the generalized hypertonia need muscle relaxants and sedatives. Diazepam is used in the dose of 0.1–0.2 mg/kg IV either as intermittent doses 2–4 hourly or as a continuous infusion in severe cases. Prolonged administration is required for up to 6 weeks for muscle relaxation. Other agents used may include chlorpromazine, benzodiazepines, Baclofen and magnesium sulphate. Sometimes IV phenobarbitone may also be helpful. In intensive care settings use of neuromuscular blocking agents like vecuronium and pancuronium along with mechanical ventilation can give better survival rates.

### Eradication of *C. Tetani*

To eradicate *C. tetani*, inj. Crystalline penicillin 1 lac units (=100,000 units)/kg per day IV in 4 divided doses for 10–14 days is the antibiotic of choice. Alternative for penicillin hypersensitive patient are Erythromycin, Tetracycline or Metronidazole.

### Intensive Supportive Care

Supportive care is an essential part of looking after tetanus patients. A quiet, dimly lit room with minimal handling is important. All care taking activities and medications should be timed to cause as little stimulation as possible. Equipment for emergency ventilatory support must be readily available.

### Prevention of Recurrence

Tetanus does not confer any immunity after recovery and all patients must be fully immunized after recovery irrespective of the age group.

#### Key Learning Points

- ➡ Exotoxin produced by tetanus bacilli, tetanospasmin is responsible for the clinical features
- ➡ A tetanus patient usually remains conscious even with severe spasms and opisthotonus.

## Other Clostridial Infections

### *Clostridium Botulinum*

*C. botulinum* causes Botulism of which three presentations are known:

1. Infantile botulism due to intake of contaminated honey or similar items.
2. Food borne botulism seen in older age groups or adults due to ingestion of food contaminated with *C. botulinum*. This contamination can occur in canned as well as non-canned foods.
3. Botulism due to wound infection is less common.

Botulinum toxin is the most poisonous substance known. It causes neuromuscular blockade leading to motor paralysis of all muscles of body. The diagnosis is mainly clinical. Treatment consists of intensive supportive care and administration of human derived botulinum antitoxin especially in infants. No antibiotics are required for *C. botulinum* as the organism undergoes lysis and releases the toxin.

### *Clostridium Difficile*

*C. difficile* has been associated with pseudomembranous colitis or antibiotic associated diarrhoea. It produces two types of toxins, which are responsible for death of intestinal cells, inflammatory response and the formation of a pseudomembrane. The clinical presentation can range from mild diarrhoea to an explosive onset of watery diarrhoea with blood, fever and abdominal pain. Treatment includes stopping the offending antibiotics, if possible and to restore normal gut flora. The accompanying fluids and electrolytes disturbances need correction. The specific treatment is given for severe cases with oral Metronidazole or IV Vancomycin.

## ENTERIC FEVER (TYPHOID FEVER)

Enteric fever or typhoid fever is caused by Salmonella group of organisms. Salmonella are gram-negative bacilli with flagellar motility. There are 2463 serovars of salmonella, which are broadly classified, as Typhoidal or Non-typhoidal.

### Aetiology

The 'Typhoidal' salmonellae are comprised of *S. typhi*, *S. paratyphi* A, B and C. The classical Typhoid fever is caused by *S. typhi* while the paratyphi causes a less severe febrile illness.

### Epidemiology

Typhoid fever occurs worldwide but incidence differs according to the sanitation and hygiene levels. In developing countries where insanitary conditions are prevalent, it continues to be a significant infectious disease and a public health problem. Man is the only reservoir. Infection occurs through oro-fecal route due to ingestion of contaminated water and food. As asymptomatic persons can continue to

excrete the bacilli for months to years, food handlers can be an important source of infection. Contaminated water cultivation of oysters and shellfish can also cause infections. Salmonella can cross the placental barrier in a pregnant mother to infect the fetus.

### Pathogenesis

During a variable incubation period ranging from 3–30 days, the organisms invade the intestines through Peyer's patches and then travel via lymphatics to mesenteric nodes to reach blood stream through thoracic duct. This leads to primary bacteraemia followed by proliferation of the bacilli in the reticulo-endothelial organs. From there the organisms re-enter the blood stream causing secondary bacteraemia and the clinical illness. The proliferation in Peyer's patches causes sloughing, necrosis and ulceration of the intestinal mucosa. These typhoid ulcers can become deep and lead to haemorrhage or perforation. During the second phase of bacteraemia, gallbladder is seeded and can become a reservoir of bacilli in carriers from where the organism is excreted through bile into the intestines and faeces. The organism has a somatic antigen (O), flagellar antigen (H) and a capsular antigen (Vi). The Vi antigen interferes with phagocytosis. It also produces an antitoxin, which causes the toxic symptoms of typhoid.

### Clinical Features

Typhoid fever occurs at all ages including neonates. The clinical presentation may vary a little with age but fever is a universal symptom. Initially it may be low grade but increases in few days to become high grade and persistent. The fever is soon accompanied by abdominal symptoms like diarrhoea, abdominal pain, vomiting and loss of appetite. There may also be cough and myalgia. The child by the second week appears sick and toxic with a coated tongue, hepatomegaly and a tender abdomen. Soft splenomegaly may also be present. The rashes of typhoid, rose spots, are frequently transient and faint and hence not easily visualized. Some respiratory signs like rales may also appear. A tender mass palpable in right hypochondrium suggests a calculus cholecystitis. Sometimes liver involvement can lead to a clinically manifest hepatitis with jaundice and tender hepatomegaly. In severe cases an encephalopathy like picture—Coma vigil can occur. The patient lies in bed with open eyes but oblivious of surroundings.

### Complications

Complications are less frequent in children than adults. Two dreaded intestinal complications, which usually occur in 2nd or 3rd week of illness, are haemorrhage and perforation. In both situations patients can suddenly collapse with

shock, tachycardia and drop in temperature. Perforation may be indicated by increase in abdominal pain, distension and features of peritonitis. A surgical intervention may be required. For both conditions intensive supportive care is required. Repeated blood transfusions may be required for a bleeding typhoid ulcer.

*S. typhi* can invade any organ of the body to cause inflammation ranging from meningitis, endocarditis, myocarditis to osteomyelitis and arthritis. Certain late neurological complications like acute cerebellar ataxia, chorea, and peripheral neuritis have also been reported.

### Diagnosis

Blood culture for *S. typhi* is the confirmatory test. It becomes positive in the first week itself. Bone marrow aspirate culture has a higher sensitivity of 85–90%. Polymerase chain reaction has also been used to detect typhoid and has a good specificity and sensitivity. Cultures of urine and stool can be positive for salmonella but are not considered useful in diagnosis.

Widal test, a serological test, used to measure antibodies against O and H antigens is commonly used for aiding in diagnosis. It has a fairly high rate of false positive and negative. In addition, the baseline antibody levels of different communities may differ according to the endemicity of the disease in the region. The immunization may also affect the antibody levels. A careful interpretation of Widal results is required keeping in mind the clinical picture of the patient and the above factors.

Haematological investigations can show anaemia due to infection/blood loss as well as poor intake. Leucopenia is the usual finding in typhoid but in younger children leucocytosis is more common.

### Treatment

Treatment of typhoid fever has been evolving. Chloramphenicol was and still is the drug of choice in most places. It is given as 50 mg/kg per day in four divided doses for 2 weeks. In many developing countries, *S. typhi* has become resistant to chloramphenicol and other drugs used like ampicillin, sulphamethoxazole-trimethoprim. Third generation cephalosporins like ceftriaxone are recommended in such situations with or without combination of aminoglycoside. Quinolones like ciprofloxacin, ofloxacin have also been found to be effective but need to be used with caution in young children.

Supportive therapy includes providing adequate fluids and nutrition either orally or parenterally. If child can take orally, a soft low residue diet is advised initially. During hospitalisation hygiene measures must be instituted to prevent cross infection.

Typhoid immunisation is advised for children travelling to areas where sanitation standards may be poor, although it is not a substitute for scrupulous personal hygiene.

#### Key Learning Points

- ⇒ Fever with abdominal symptoms and signs are a common presentation of typhoid fever
- ⇒ The gold standard, confirmatory test for typhoid is blood culture.

### Non-typhoidal Salmonellosis

Non-typhoidal salmonellosis is caused by a number of organisms similar to *S. typhi* but have different serotypes (e.g. *S. dublin*, *S. typhimurium*, *S. cholera-suis*, *S. marina*). Unlike *S. typhi*, animals are important source of human infection for non-typhoidal salmonellae. Poultry and related products are responsible for a number of outbreaks. The infection has a short incubation period of 6–72 hours. The common clinical presentation is of acute enterocolitis. In neonates, young infants, malnutrition and other immuno-compromised states they can cause a more invasive disease leading to septicaemia like picture and meningitis. Seeding of bones can lead to osteomyelitis especially in children with sickle cell anaemia. The diagnosis is by culturing the organism from stool or other areas of involvement. Treatment is same as for typhoid fever.

### CHOLERA

Cholera, caused by *Vibrio cholerae*, is an acute gastrointestinal infection. It is a major public health problem especially in developing countries.

#### Aetiology

*V. cholerae* is a gram-negative, motile, comma shaped organism with a flagellum. Two pathogenic strains *V. cholerae* 01 and 0139 are known. The 01 strain has two bio groups i.e. Classic and El Tor and there are further serogroups of O antigens viz. Ogawa, Inaba and Hikojima.

#### Epidemiology

Cholera has been known to occur for centuries in various parts of the world. It has not only an endemic or sporadic presence but has caused epidemics as well as pandemics. The route of infection is feco-oral. Contaminated water serves as a reservoir and frequently the source of the infection. Other sources of infection include contaminated foodstuffs, utensils and houseflies. There are no animal reservoirs of infection.

#### Pathogenesis

Cholera has one of the shortest incubation periods of 6 hours to 5 days. After ingestion, the organisms have to pass

through the acid barrier of stomach. Once they survive that, they colonize the upper small intestines. For colonization, a relatively large inoculum of *V. cholerae* is required. The organisms produce an enterotoxin, cholera toxin, which causes the symptoms. The toxin enters the intestinal epithelial cells, binds and activates the enzyme adenylyl cyclase. As a result, cyclic AMP levels increase. This leads to decreased absorption of sodium and chloride from villous cells and also an active secretion of chloride. As sodium absorption is impaired, water is poured out from intestinal epithelium. The outpouring of fluid and electrolytes produces the watery diarrhoea and the related changes.

#### Clinical Features

Cholera infection can be a mild self-limiting disorder or even asymptomatic. Severe infection leads to profuse watery diarrhoea accompanied by vomiting. In young children there can be significant fever. The stools are watery with a fishy odour and the mucus flakes give it the typical rice water appearance. The fluid and electrolyte loss can be massive leading to symptoms and signs of severe dehydration and even circulatory collapse and acute renal failure. The outpouring of watery diarrhoea can continue for 5–7 days.

#### Diagnosis

Examination of fresh stool sample as a hanging drop preparation under the microscope can show the darting motile *V. cholerae*. There are generally no fecal leucocytes. Stool culture confirms the diagnosis as well as helps in identifying the type. *V. cholerae* is best cultured on thiosulphate citrate bile sucrose media (TCBS).

The estimation of serum electrolytes and blood sugar levels is useful for appropriate management of sick children.

#### Treatment

The mainstay of treatment is replacement of fluid and electrolytes losses. If the child can take orally then oral rehydration solution (ORS) should be given ad libitum. In case oral intake is not possible or inadequate, intravenous rehydration is essential. Hyponatraemia, hypokalaemia and acidosis need appropriate attention.

Antibiotics can help in shortening the duration of illness and possibly the carrier rate. The drug of choice is oral tetracycline for 3 days. In younger children, trimethoprim-sulphamethoxazole combination can be used. Furazolidone has also been used.

#### Complications

All the complications and even the mortality are related to the fluid and electrolyte losses. Hence prompt and appropriate treatment can prevent the complications.



## Prevention

Besides good hygiene and public health measures no other practical methods are there for prevention of cholera. Three types of vaccines are available in the world. The commonly used one is a parenterally administered, phenol-killed vaccine with an efficacy of 50% and immunity lasting up to 6 months. There are two oral vaccines; one killed subunit and another live attenuated. Their efficacy is reported to be better but again protection lasts 6 months. None of them protect against 0139 strain.

### Case Study

An 8-year-old boy was brought to the emergency service with a history of frequent, profuse watery stools, fever and vomiting for one day. The stools were whitish, watery with a peculiar fishy odour. The child was severely dehydrated and was in shock. He was resuscitated with intravenous fluid therapy. His serum sodium was 265 meq/l, potassium 3.5 meq/l, chloride 85 meq/l. Stool hanging drop preparation showed organisms with Vibrio like morphology and motility. He was given oral doxycycline and continued on IV fluids. He made a complete recovery in 4 days.

*Diagnosis:* Cholera

### Key Learning Points

- Cholera has a short incubation period of 6 hours to 5 days
- Typical cholera stools are watery, rice water in appearance with fishy odour
- Appropriate fluid and electrolyte replacement is life-saving in cholera.

## SHIGELLOSIS

Shigellosis is caused by shigella group of organisms. There are four aetiological species namely *Shigella dysenteriae*, *S. flexneri*, *S. sonnei* and *S. boydii*.

### Epidemiology

*S. dysenteriae* is endemic in Asia and Africa and can cause epidemics. The infection is more common during warm season and source is contaminated water and food. Shigella can survive in milk for up to 30 days. Flies also excrete shigella. Unlike Cholera, a small inoculum of 10 to 100 bacteria is adequate to cause disease. Asymptomatic individuals can carry Shigella organisms and be a source of infection. Person to person transmission due to poor hand washing also occurs.

### Pathogenesis

Shigellas are invasive organisms and affect the colon. There is colitis with mucosal edema, ulceration and bleeding. The

deeper layer of colonic wall, i.e. muscularis mucosa and submucosa can also be affected by the inflammatory process. *S. dysenteriae* also produces an exotoxin, shiga toxin, which can cause watery diarrhoea.

### Clinical Features

All four types cause similar clinical picture although severity may vary. After an incubation period of 12 hours to several days, the clinical presentation may start with loose stools, abdominal pain, fever and vomiting. Soon the fever becomes higher; there are severe abdominal cramps, tenesmus with blood in stools. Abdominal examination may reveal distension and tenderness. There can be accompanying features of fluid and electrolyte loss. In some children, neurological manifestations like convulsions, headache and lethargy may occur.

### Complications

- Dehydration and dyselectrolytaemia
- Sepsis and bacteraemia can occur with *S. dysenteriae* and organisms may be isolated from blood culture
- Haemolytic uremic syndrome is mediated by shiga toxin
- Persistent diarrhoea and malnutrition
- Rectal prolapse—In malnourished children there can be rectal prolapse due to tenesmus.

### Diagnosis

Stool examination can show numerous leucocytes. Culture of stool for Shigella proves the diagnosis. There is leucocytosis and in some children leukemoid reaction can also occur. In sick and toxic looking children, blood culture should also be obtained.

### Treatment

The priority is on correcting the fluid and electrolyte balance with either oral or intravenous rehydration. Antibiotic therapy is recommended as it shortens the episode and improves the outcome and also decreases carrier state. The choice may depend on culture sensitivity if available. Oral ampicillin, trimethoprim-sulphamethoxazole or Nalidixic acid all are effective. In older children quinolones may also be used.

## STREPTOCOCCAL INFECTIONS

*Streptococcus pyogenes* or group A Streptococcus is known to cause acute infection of the respiratory system and skin. It is also responsible for certain clinical syndromic conditions like scarlet fever, necrotizing fasciitis and toxic shock syndrome and post infectious entities like acute rheumatic fever and acute glomerulonephritis.

## Aetiology

Streptococci are gram-positive cocci seen in chains. They are categorized into three categories depending on their ability to cause haemolysis viz. beta ( $\beta$ )-haemolytic causing complete haemolysis, alpha ( $\alpha$ ) cause partial haemolysis while gamma ( $\gamma$ ) cause no haemolysis. The  $\beta$ -haemolytic streptococci are further divided based upon polysaccharide components in their cell wall. These groups known as Lancefield grouping range from A to T.

## Epidemiology

Group A streptococci cause highly contagious disease and all persons not having immunity to it are susceptible. Humans are the source of infection and transmission occurs by droplet infection from respiratory passages. Overcrowding, close contact favour the spread of infection. Skin infections occur only after a break in the normal barrier, as streptococci do not penetrate intact skin.

## Pathogenesis

The pathogenesis and virulence of group A *Streptococcus* is related to presence of M proteins. M protein rich streptococci resist phagocytosis and also generate a protective antibody response. The streptococci produce a variety of toxins and enzymes. Streptococcal erythrogenic or a pyrogenic toxin is one of these and responsible for causing invasive diseases. Certain other substances also cause antibody production but not immunity. One of these is streptolysin O (antigen) and the antibody is antistreptolysin O (ASO). The ASO levels are measured as an evidence of a recent streptococcal infection. Another similar antibody is anti-deoxy ribonuclease (anti-DNase).

## Clinical Features

In addition to the common respiratory and skin infections, *Streptococci A* are also associated with a number of other acute infective as well as non-infective conditions (Table 26.2).

**Table 26.2:** Diseases caused by Group A *Streptococcus*

Infective conditions	Non-infective conditions
<ul style="list-style-type: none"> <li>Acute pharyngitis/pneumonia</li> <li>Scarlet fever</li> <li>Impetigo – Bullous</li> <li>Non bullous (Fig. 26.3)</li> <li>Erysipelas</li> <li>Perianal dermatitis</li> <li>Vaginitis</li> <li>Toxic shock syndrome</li> <li>Necrotizing fasciitis</li> </ul>	<ul style="list-style-type: none"> <li>Acute rheumatic fever</li> <li>Post streptococcal GN</li> <li>Post streptococcal reactive arthritis</li> <li>Paediatric autoimmune neuropsychiatric disorders associated with Streptopyogenes (PANDAS)</li> </ul>



**Fig. 26.3:** Impetigo lesions

## Scarlet Fever

The illness starts as an upper respiratory infection. Soon, within 24–48 hours, a rash appears, first around the neck and then spreads to trunk and extremities. The rash is brightly erythematous, diffuse, and finely papular giving a sand paper feel of the skin. The face is usually not involved with rash but there is characteristic perioral pallor. The rash fades in 3–4 days leading to desquamation. During the acute stage, the pharynx is also inflamed and tongue is coated and inflamed. Later the papillae appear swollen and red giving rise to the 'strawberry tongue'.

## Erysipelas

Streptococcal infection of the subcutaneous deeper layers and connective tissue is known as erysipelas. The child has fever and other constitutional symptoms. The involved area has the signs of inflammation and is very tender. There may be few overlying blebs. There is a sharp demarcation of the involved area.

## Invasive Streptococcal Disease

Isolation of streptococci from sterile body sites with serious systemic manifestation is taken as invasive disease. This can be in the form of toxic shock syndrome, necrotizing fasciitis or other systems involvement e.g. meningitis, septicemia, osteomyelitis, etc.

## Diagnosis

Isolation of *Streptococcus A* from the site of infection is confirmatory. The only exception to this can be asymptomatic chronic carriers with organism in the pharynx. Rapid antigen

detection test with high specificity but medium sensitivity are available and are useful for a quick diagnosis although they are expensive. Evidence of a recent streptococcal A infection can be seen from ASO titres especially increasing titres. ASO titres of 320 Todd unit are significant in children while for anti-DNAse the value is 240 Todd unit or greater. The values in adults are 240 and 120 Todd units respectively.

### Treatment

The antibiotic of choice for *Streptococcus A* is penicillin. Resistance to penicillin is infrequent. It can be given orally or parenterally but must be continued for complete 10 days to eradicate streptococci. In hypersensitive patients, erythromycin can be given for 10 days.

For skin infections, topical antibiotics can be used. Mupirocin is effective but if a child has wide spread infection or systemic features, oral treatment maybe indicated.

## PNEUMOCOCCAL INFECTIONS

Pneumococcus or *Streptococcus pneumoniae* is a frequent inhabitant of upper respiratory tract. It is a common cause of meningitis and acute respiratory infection. It is gram-positive capsulated diplococci and based on capsular polysaccharide, ninety serotypes have been identified.

### Epidemiology

More than 90% of children below 5 years of age have pneumococci in their respiratory tract sometime or other. The route of infection is by droplet infection. Children with asplenia, sickle cell disease and immunocompromised states are more susceptible to pneumococcal infections.

### Pathogenesis

Normal defence mechanisms of the respiratory passages, e.g. ciliary movements, epiglottic reflex, etc. inhibit infection of lower passages with organisms like pneumococci, which colonize the upper passages. Any conditions altering these mechanisms like a preceding viral infection or allergy can predispose to pneumococcal disease. The commonly involved sites are lungs, ears, CNS. The spread of infection is facilitated by the anti-phagocytic properties of the capsular polysaccharide of bacteria.

### Clinical Features

Clinical presentation depends on the site of involvement. Upper respiratory tract infection may present predominantly as an otitis media, tonsillopharyngitis or sinusitis. Lower respiratory tract involvement may be seen as pneumonia. An invasive infection can cause bacteraemia and septicaemia. Pneumococcal peritonitis occurs rarely as a spontaneous

infection. Serious systemic involvement can also occur as meningitis, osteomyelitis, arthritis or endocarditis.

### Diagnosis

Culturing pneumococci from the site of infection, viz. throat, blood or CSF establishes the diagnosis.

### Treatment

Penicillin is the drug of choice either parenterally or orally depending upon the severity of the disease. Penicillin resistant pneumococci are becoming common and culture sensitivity is helpful in making a choice of antibiotic easier. Macrolides, trimethoprim-sulphamethoxazole, clindamycin, and amoxicillin-clavulanic acid are other alternatives, which can be used for oral therapy.

## MENINGOCOCCAL DISEASE

Meningococcal meningitis was described over two centuries back but it still remains a feared public health problem.

### Aetiology

The causative organism *Neisseria meningitidis* is gram-negative kidney shaped diplococci. Humans are the only source of infection. Many individuals carry the organism in their nasopharynx. The polysaccharide capsule of the organism has antigen variation and based on that 13 serotypes have been identified. The well-known serotypes are A, B, C, W 135 and Y.

### Epidemiology

Meningococcal infections are endemic in many parts of the world and are marked by periodic outbreaks in geographical areas. Overcrowding, low socioeconomic status, and viral infections are risk factors for the infection. The route of infection is through respiratory droplet infection. Serotypes A, B and C are variably responsible for endemic disease as well as outbreaks.

### Pathogenesis

The meningococci first attach themselves to non-ciliated epithelial cells and gain entry to the blood stream. They are protected by their polysaccharide capsule, which resists phagocytosis. After invasion, there is an acute inflammatory response, diffuse vasculitis, disseminated intravascular coagulation (DIC) leading to focal necrosis and haemorrhage. Any of the organs can be affected. In meningococemia, myocarditis occurs in more than half the fatal cases. Waterhouse-Friderichsen syndrome due to adrenal haemorrhage can be another fatal complication.



**Fig. 26.4:** Extensive purpuric lesions in a child with overwhelming meningococcaemia

### Clinical Features

Meningococci can cause clinical disease in the form of meningitis, septicaemia or meningococcaemia.

Acute meningococcaemia is a fulminant disease. The initial presentation is similar to a viral illness with fever, headache, myalgia and pharyngitis. An erythematous generalized maculopapular rash may also be seen. The disease can rapidly progress to hypotension, DIC, septic shock, adrenal haemorrhage, myocarditis or renal failure. Multiple petechiae, purpuric spots and purpura fulminans may be seen. Meningitis is not a necessary feature (Fig. 26.4).

Meningococcal meningitis can occur with or without meningococcaemia. All the features of meningitis are seen. Occasionally only cerebral involvement is present. Rarely meningococci can cause pneumonia, osteomyelitis, cellulitis, otitis media and empyema.

### Diagnosis

Culturing meningococci from CSF or blood is diagnostic. Rapid diagnostic tests like latex agglutination are helpful especially in seriously ill patients.

### Treatment

Parenteral penicillin is the drug of choice. Third generation cephalosporins can also be used. Chloramphenicol is also effective. In sick patients intensive supportive care with vasopressors, etc. is required. Hydrocortisone supplementation may be helpful in patients with shock. The patient should be kept isolated for at least 24 hours after starting of treatment.

Household and other close contacts of the patient need prophylactic therapy. Rifampicin 10 mg/kg 12 hourly for four doses is recommended. Other antibiotic used for chemoprophylaxis is Ciprofloxacin.

## HAEMOPHILUS INFLUENZAE

### Aetiology

Haemophilus influenzae is a gram-negative, pleomorphic coccobacillus. Serotype B is the most common and most virulent strain.

### Epidemiology

*H. influenzae* is seen in the respiratory flora of normal healthy persons. Humans are the only reservoirs. The mode of transmission is from droplet infection.

### Clinical Features

*H. influenzae* can cause a wide range of illness primarily affecting the respiratory system and meningitis (see Table 26.3).

**Meningitis:** The clinical presentation is like any other meningitis. It is often associated with post-meningitic sequelae in the form of sensorineural hearing loss, developmental retardation, seizures, ataxia and hydrocephalus.

### Diagnosis

*H. influenzae* is a fastidious organism to culture and requires care. The specimens must be promptly transported without drying or at extreme temperatures. Positive culture or smear from the affected site confirms the diagnosis.

### Treatment

In a suspected *H. influenzae* B infection, ampicillin or chloramphenicol are recommended. Third generation cephalosporins like cefotaxime or ceftriaxone are also useful. The treatment should be initially given parenterally and after adequate response oral therapy can be considered. In meningitis, parenteral therapy for 10–14 days must be given. Addition of dexamethasone in initial stages of meningitis especially just before antibiotic therapy decreases the incidence of hearing loss.

**Table 26.3:** Clinical disease caused by *H. influenzae* Type B

Respiratory	Miscellaneous
Epiglottitis	Cellulitis
Sinusitis	Arthritis
Otitis media	Pericarditis
Pneumonia	Septicaemia
Eye	Neonatal infection
Conjunctivitis	
Orbital cellulitis	

## Prevention

Unvaccinated children below 5 years of age in contact with a case need chemoprophylaxis with Rifampicin in a dose of 20 mg/kg for 4 days.

## STAPHYLOCOCCAL INFECTIONS

Staphylococci are gram-positive cocci and are present as normal flora in a ubiquitous manner in humans, animals and on fomites. They are resistant and hardy bacteria. They are broadly classified as *Staphylococcus aureus*, coagulase positive or coagulase negative Staphylococci (CONS).

### *Staphylococcus Aureus*

*S. aureus* is a common infective organism. It causes a variety of infections of many organs or a generalized sepsis. The organisms produce various toxins and enzymes, which are largely responsible for the pathogenesis. Different strains produce one or more of these virulence factors, which may have a combination of the following mechanisms of action.

- Protection of the organism from host defence mechanisms e.g. Leukocidin, Protein A
- Local tissue destruction e.g. Hemolysins, exfoliations
- Toxins affecting non-infected sites. e.g. Enterotoxins
- Localized infection e.g. coagulase.

### Epidemiology

Within a week after birth, the newborn infant is colonized with *S. aureus*. Nearly one third of normal individuals carry a strain of *S. aureus* in their anterior nares from where it can be transmitted to skin. Autoinfection can commonly cause minor infections. Persons harbouring *S. aureus* in nose can be a frequent source of infection to others especially nosocomial infections. Defects in mucocutaneous barrier like trauma and surgery increase the risk. Defects in immune system like defective chemotaxis or phagocytosis or humoral immunity predispose to infection.

### Clinical Features

The clinical presentation depends on the site of infection and virulence of the organism. Skin infections are the commonest. Involvement of the respiratory system is a frequent occurrence. Other systemic involvements also occur (Table 26.4).

### Diagnosis

Isolation of *S. aureus* from the affected site is diagnostic. Antibiotic sensitivity testing must be done to plan appropriate therapy.

**Table 26.4:** Systemic involvement with *S. aureus*

Skin	Respiratory system	Musculoskeletal system
Impetigo	Lobar pneumonia	Pyomyositis
Ecthyma	Bronchopneumonia	Osteomyelitis
Folliculitis	Empyema	Arthritis
Furuncle	Pyopneumothorax	
Carbuncle	Necrotizing pneumonia	
Scalded skin syndrome	Bronchopleural fistula	
CNS	Heart	Kidney
Meningitis	Infective endocarditis	Renal abscess
Brain abscess	Purulent pericarditis	Perinephric abscess
Gastrointestinal	Septicaemia	Toxic shock syndrome
Enterocolitis		
Food poisoning		

### Treatment

Parenteral antibiotics are used to treat all serious infections. Only for minor skin infections, oral therapy can be given. Treatment should be with a penicillinase resistant antibiotic and in combination with at least one more antibiotic. Serious staphylococcal infections may require more than two antibiotics. Prolonged therapy is usually required especially for osteomyelitis and endocarditis, which can be given orally after the features of infection have disappeared. In addition to antibiotics, any localized collection of pus, if present, must be drained.

### MRSA (methicillin resistant *Staphylococcus aureus*)

*Staphylococcus aureus* strains resistant to methicillin and to flucloxacillin have emerged; some of these organisms may be sensitive to vancomycin or teicoplanin. Treatment is guided by the sensitivity of the infecting strain. It is essential that hospitals have infection control guidelines to minimise MRSA transmission, including policies on isolation and treatment of MRSA carriers, and on hand hygiene.

### Coagulase Negative *Staphylococcus aureus* (CONS)

*S. epidermidis* is the most well-known from this group. These cause sepsis in patients with indwelling devices, surgical trauma and immunocompromised hosts especially small neonates. They can cause septicaemia, endocarditis, urinary tract infection, device infection, e.g. shunt infection. As *S. epidermidis* is a normal inhabitant, isolation from blood culture may indicate contamination. True bacteraemia is considered if more than one blood culture is positive. For treatment, antibiotic susceptibility reports are helpful. The indwelling device responsible for sepsis must be removed.

## TUBERCULOSIS

Tuberculosis, an ancient disease, occurs in all parts of the world with variable frequency. It has been given many names and has a very diverse spectrum of clinical presentation.

### Aetiology

The causative organism, *Mycobacterium tuberculosis* belongs to family mycobacteriaceae. The tubercle bacilli are pleomorphic, weakly gram-positive, non-motile, non-spore forming organisms. The characteristic feature of all mycobacteria is their resistance to acid decolouration after staining, a property attributed to the mycolic acid in their cell wall. Most mycobacteria are slow growing organisms. Their generation time is 12–24 hours and cultures require at least 3–6 weeks.

### Epidemiology

WHO estimates that one third of the world's population is infected with *M. tuberculosis*. Out of these, more than 95% of the tuberculosis (TB) cases occur in developing countries. The ongoing HIV epidemic, poverty, crowded populations and inadequate TB control programs have all contributed to this.

The most common route of infection is through respiratory secretions containing TB bacilli. Patients with sputum positive for acid-fast bacilli (AFB) are the source of infection. Persons with copious sputum or a severe, forceful cough and a closed ill ventilated environment increase the likelihood of transmission. There is no transmission from fomites or from direct contact with secretions. Young children are usually not infective. Other possible route of infection is through gastrointestinal system if the bovine strain *M. bovis* is ingested. Congenital TB occurs if mother has TB during pregnancy, which is transmitted through placenta to the foetus.

HIV and TB share a symbiotic relationship. TB is more common, widespread and severe in persons with HIV infection. Recently, the World Health Organisation has reported that the very rare strain Extremely Drug Resistant TB (XDR-TB) accounts for possibly only 2% of the million cases of tuberculosis in the world, but that it poses a grave public health threat, especially in populations with high rates of HIV and where there are few health care resources. XDR-TB poses a far greater challenge to doctors than MDR-TB (Multidrug Resistant TB), which is resistant to at least the two main first-line tuberculosis drugs, isoniazid and rifampicin. XDR-TB is a form of MDR-TB that is also resistant to three or more of the six classes of second-line drugs. Recent findings from a survey found that XDR-TB had been identified in all regions of the world but was most frequent in the former Soviet Union and Asia.

### Pathogenesis

After infection through the respiratory route, the TB bacilli start multiplying in the lung alveoli. Most are killed but some bacilli survive which are intracellular in the macrophages. The macrophages carry them along the lymphatics to the lymph nodes, usually the hilar nodes or in case of upper lobe the paratracheal nodes. The organisms multiply and lymphatic reaction increases over the next 12 weeks. There is also development of tissue hypersensitivity. The whole complex of parenchymal lesion along with the involved lymphatics and the draining lymph nodes are known as the primary complex. The infection at this stage can become dormant with healing of the primary complex by fibrosis or calcification. The tuberculin skin test is positive at this stage. Or there can be progression of the disease, the risk being greatest in children within 2 years of infection. The risk gradually decreases till adulthood.

### Immunity

Immunity in TB is an important determinant of the spread of the disease as well as the presentations. The primary immune response is cell-mediated immunity (CMI), which develops 2–12 weeks after infection. Progression from TB infection to TB disease is affected by cell-mediated immunity. In individuals with decreased CMI due to any reason the disease disseminates whereas in those with good CMI and tissue hypersensitivity there is a granuloma formation restricting the infection to a localized area.

### Progress of Primary Infection

The primary infection in the form of primary complex can have variable outcome.

- Progressive primary complex
- The primary complex enlarges with pneumonitis and pleuritis. There can be associated caseation and liquefaction. The radiological appearance shows a segmental lesion with lymph node enlargement
- Partial obstruction of a bronchus due to enlarged lymph nodes can cause emphysematous appearances (Fig. 26.5)
- The caseous nodes can erode through a bronchus and empty into the distal lung giving rise to a bronchopneumonia
- The bronchi adjacent to the tuberculous nodes can get thickened and develop endobronchial tuberculosis
- The haematogenous spread from a primary infection can cause miliary tuberculosis.

During the primary infection, the TB bacilli seed various organs through blood borne or lymphatic spread. If the number of bacilli are more and the host immunity inadequate, disseminated TB occurs. In children with good immunity and less bacilli, the seeding of the organs becomes dormant. This can get reactivated at any time when the balance of immunity



**Fig. 26.5:** Tuberculous lymph nodes compressing the trachea

**Table 26.5:** Time interval from primary infection

Disseminated TB	2-6 months
TB meningitis	2-6 months
Osteomyelitis/Arthritis	Several years
Renal TB	Decades

changes. The presentation of the involvement of these organs can be variable (Table 26.5).

### Clinical Features

The clinical presentation of TB can be either of pulmonary symptoms and signs only or of any other organ system involvement or a mixed picture. In children, approximately 25–30% cases are of extrapulmonary TB.

**Pulmonary TB:** The symptomatology of pulmonary TB is almost uniform across various types of involvement in the lungs. Children tend to have more non-specific symptoms. Cough, low-grade fever, loss of appetite, lethargy and weight loss are usual symptoms. Failure to thrive is one of the commonest presentations. The additional clinical signs of the disease depend upon the type and extent of the involvement. There may be no clinical signs or range from findings of pleural effusion, consolidation and bronchopneumonia. In military type of pulmonary TB, there may be high-grade fever, toxic look and splenomegaly.

**Extrapulmonary TB:** Any organ can be involved by tuberculous infection. In children, CNS TB is a frequent occurrence. Depending upon the extent of involvement, CNS tuberculosis can have variable clinical picture (see chapter 18).

**TB lymphadenitis:** Lymphadenitis due to *M. tuberculosis* is one of the common forms of extrapulmonary TB seen at all ages. The nodes draining the lungs fields are usually involved. The common groups of nodes involved are

cervical and axillary but other groups can also be involved especially secondary to drainage from an infected organ. The node involvement usually occurs 6–9 months after primary infection. The affected nodes are firm, non-tender, fixed and often matted due to periadenitis. There may be accompanying low-grade fever. In case a node breaks down, it leads to sinus formation.

**Disseminated TB:** Two forms of disseminated spread are seen. In disseminated TB, the organs seeded during the haematogenous spread begin to get active involvement. Usually, there is fever, hepatosplenomegaly and lymphadenopathy. Other organs may also be involved.

In the other more serious disseminated form of TB, there is a large haematogenous spread and in a patient with inadequate immune response there is miliary TB. It can occur at any age but is more common in young children. It usually occurs 2–6 months after primary infection. Miliary TB may start with an insidious fever, malaise and loss of appetite. Soon fever rises and there is lymphadenopathy with hepatosplenomegaly. There can be an acute presentation of miliary TB also. The child looks toxic with high fever, has dyspnoea along with crepitations in the chest and hepatosplenomegaly. There can be extra-pulmonary involvement with meningitis in which there may be characteristically choroid tubercles on fundoscopy. Choroid tubercles indicate end artery embolisation with formation of tubercles.

**TB of bones/joints:** Skeletal tuberculosis is a late complication. The commonest site of involvement is vertebra leading to the classical Pott's spine with a formation of gibbus and kyphosis. Tuberculosis of any bone can occur. Dactylitis of metacarpals is seen in children. Tuberculous arthritis of any of the joints can occur.

**Abdominal TB:** In the abdomen there are two major clinical presentations, viz. tuberculous peritonitis and tuberculous enteritis.

Tuberculous peritonitis is uncommon in children but can occur due to either haematogenous spread or local extensions from abdominal lymph nodes or intestines. Low-grade fever and pain, ascites, weight loss are the typical features. Tuberculous infection of the intestines occur either secondary to haematogenous spread or from ingestion of TB bacilli from sputum. Small intestines and appendix are the usual sites of the involvement. Tuberculous ulcers or later strictures can cause the clinical features. Low-grade fever, weight loss, diarrhoea or constipation or features of sub-acute intestinal obstruction can be the presenting features.

**Genitourinary TB:** Renal TB has a long incubation period and hence is generally seen in older children or adolescents. Kidneys as well as other parts of the urinary system can be involved. Renal involvement is unilateral and initially present as sterile pyuria and microscopic haematuria. Later abdominal pain and mass, dysuria and frank haematuria with

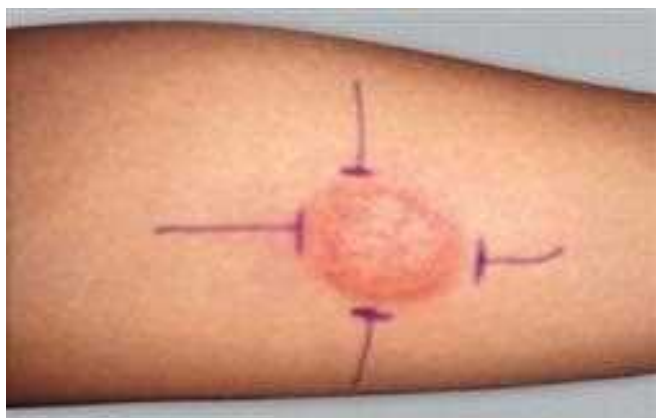


Fig. 26.6: A positive Mantoux test

progression to hydronephrosis or urethral strictures may be seen.

**Congenital TB:** Perinatal transmission of TB can occur as a haematogenous spread through the placenta in mother with active disease. Inhalation/ingestion of infected amniotic fluid or exposure after birth to a positive contact can also cause infection in a neonate. The transplacental infection presents with a primary complex like manifestation in the abdomen. The liver has the focus with the nodes in porta hepatis also involved. If the infection is through inhalation or the haematogenous spread occurs further to lungs then respiratory signs are predominantly present. The neonate can have acute onset respiratory distress, fever, poor weight gain, lymphadenopathy and hepatosplenomegaly. Occasionally meningitis can also occur. The clinical signs and symptoms can be similar to other infections. A maternal history or contact with an AFB positive person should raise the suspicion.

## Diagnosis

Diagnosis of TB in children is not simple. A high index of suspicion in the endemic area is important. The modalities most frequently used for diagnosis are:

Mantoux Test (Fig. 26.6)

Radiological examination

Gastric aspirate/sputum AFB smear and culture

Polymerase chain reaction (PCR)

See Table 26.6 for further information.

## Treatment

Effective anti-tuberculous therapy requires a combination of anti-tuberculous drugs. The bacillary load is an important determinant of treatment. Children tend to have moderate load of TB bacilli as compared to large bacillary populations among adults with cavitary disease. The anti TB drugs are listed in Table 26.7. Combination of isoniazid and rifampicin with either pyrizinamide or ethambutol or both is used. The

Table 26.6: Diagnostic tests in tuberculosis

Type of disease	Mantoux test	AFB isolation	Radiology
1. Pulmonary TB	+ve except in Miliary TB	Gastric aspirate or Sputum	X-ray Chest Segmental lesions Primary complex Effusion Non specific picture
2. CNS TB	+ve can be neg in TBM	CSF AFB v.rarely PCR+	CT scan or MRI scan
3. Bones and Joints	+ve	Curettage may show AFB	X-ray of the affected area MRI
4. Abdominal TB	+ve	Not seen	Ultrasonography or CT scan may show lymph nodes
5. Genito-urinary TB	+ve	Urine AFB	IVP and ultrasonography
6. Congenital TB	May be +ve	Not seen	May not be helpful Biopsy of nodes

Table 26.7: Commonly used anti-TB drugs in children

Drug	Dose mg/kg/d	Max	Side effect/ Toxicity
<i>Bactericidal</i> Isoniazid (INH, H)	10–15	300 mg	Pyridoxine deficiency, peripheral neuritis, hepatotoxicity
Rifampicin (RIF, R)	10–20	600 mg	GI upsets, hepato-toxicity
Streptomycin (STM, S)	20–40	1 gm	Vestibular and auditory toxicity
<i>Bacteriostatic</i> Pyriznamide (PZA, Z)	20–40	2 gm	
Ethambutol (EMB, E)	15–25	2.5 gm	Optic neuritis, colour blindness

duration of treatment depends on the site of involvement and the response and can range from 6–18 months. In CNS TB and in involvement of serosal tissues like pleura/pericardium addition of corticosteroids may be required. Surgical intervention may be indicated in TB of the spine, bones or abdomen.



WHO has recently recommended directly observed therapy (DOTS) for treating all types of tuberculosis.

### DIRECTLY OBSERVED TREATMENT SHORT COURSE (DOTS)

This is a strategy to ensure cure by providing the most effective medicines and confirming its intake regularly. Worldwide it has been documented as an effective strategy to cure TB.

In DOTS, the treatment is given in two phases. During the intensive phase of treatment, a health worker or other trained person watches as the patient swallows the drugs in his presence. During the continuation phase the patient is issued medicines for one week in a multi-blister combi-pack of which the first dose is swallowed by the patient in the presence of the health worker or other trained person. The consumption of medicines in the continuation phase is also checked by return of the empty multi-blister combi-pack when the patient comes to collect medicine for the next week. Sputum microscopy is done at defined intervals during treatment to monitor the patient's progress toward cure. The key to the success of the DOTS strategy is that it places the responsibility for curing TB patients on the health workers – not the patients. This strategy has proven successful throughout the world.

The components of the DOTS strategy are:

- Diagnosis of patients by sputum microscopy
- Regular and uninterrupted supply of drugs
- Short-course chemotherapy given under direct observation
- Systematic evaluation and monitoring.

Category I: New cases that are sputum positive or seriously ill patients with smear negative or extrapulmonary disease. The intensive phase consists of isoniazid, rifampicin, pyrazinamide and ethambutol given under direct observation thrice weekly on alternate days and lasts for 2 months (24 doses). This is immediately followed by the continuation phase, which consists of 4 months (18 weeks, 54 doses) of isoniazid, rifampicin given thrice weekly on alternate days. The first weekly dose is directly observed.

Category II: Retreatment cases including patients with relapse, failure and those who return to treatment after default. Such patients are generally sputum negative. Phase one consists of two months (24 doses) of isoniazid, rifampicin, pyrazinamide, and ethambutol, all given under direct observation weekly on alternate days. This is immediately followed by the continuation phase, which consists of 5 months (22 weeks, 66 doses) of isoniazid, rifampicin, and ethambutol given thrice weekly on alternate days, the first dose of the week being directly observed.

Category III: Patients who are sputum-negative, or who have extra-pulmonary TB and are not seriously ill. Phase I consists of isoniazid, rifampicin, and pyrazinamide given under direct observation thrice weekly on alternate days and lasts for 2 months (24 doses). This is immediately followed by the continuation phase, which consists of 4 months (18 weeks, 54 doses) of isoniazid and rifampicin given thrice weekly on alternate days, the first dose of the week being directly observed.

A symptomatic child contact with a positive Mantoux test (10 mm or more) is to be treated as a case regardless of BCG status. For infants, if the mother or any other household member is smear positive then chemo-prophylaxis should be given for 3 months. At the end of 3 months, a Mantoux test is done. If the Mantoux test is negative, chemoprophylaxis is stopped and BCG vaccine is given. If the Mantoux test is positive, chemoprophylaxis is given for a total duration of 6 months.

### LEPROSY

Leprosy also known as Hansen's disease is an ancient disease. It is a chronic infection of skin, peripheral nerves and respiratory system.

#### Aetiology

The causative organism is *Mycobacterium leprae*, an intracellular acid-fast bacillus from mycobacteriaceae family, closely related to *Mycobacterium tuberculosis*. Illness usually results from prolonged exposure to infected persons. The bacterium only affects humans under natural conditions. Transmission of the disease to experimental animals is difficult. This fact hampers research into many aspects of the disease.

#### Epidemiology

World over there has been a steady decline in the prevalence of leprosy. Presently, more than 90% of cases of leprosy are in 10 countries of the world, located in Africa, SE Asia, Central and South America, with 70% in India alone. Transmission occurs from person to person among those in close contact especially the family members. The infection is transmitted through breast milk but nasal and respiratory secretions are the ones with highest bacterial load and are the usual source. Infection rarely occurs in infants but is common in the 5–14 years age group. In-utero transmission has been considered a possibility. The incubation period is between two and five years, but may be much longer. Infection spreads only by the lepromatous type of the disease.

## Pathogenesis

Most of the persons coming in close contact with *M. leprae* develop immunity without an evident disease. *M. leprae* and host immunity are two major determinants of the extent and severity of the disease in an individual. After entering through the respiratory mucosa especially nose, the bacilli spread hematogenously to skin and peripheral nerves. The organisms colonize the perineural and endoneural spaces and the Schwann cells. In hosts with good cell mediated immune response the presentation is in form of tuberculoid leprosy (TL). The tissues show granuloma formation with epithelioid cells, lymphocytes and scanty bacilli. There is no caseation or intracellular bacilli in macrophages. The cutaneous nerve fibres are destroyed with extensive cellular infiltration of the dermis.

On the other extreme in the presentation of Lepromatous leprosy (LL) where there is almost no immune response to *M. leprae*. A large number of bacilli invade the skin, peripheral nerves, nasal mucosa as well as other organs with the exception of CNS, which is not involved. There are poorly formed granulomas with foamy histiocytes and macrophages with numerous intracellular bacilli. In between the two extremes of the spectrum of presentation of Leprosy lie three other forms of borderline (BB), borderline tuberculoid (BT) and borderline lepromatous (BL) pictures with in between features.

## Clinical Features

**Tuberculoid Leprosy (TL):** The usual presentation is with a large skin lesion (> 10 cm). The lesion has a well-demarcated erythematous rim with atrophic, hypopigmented, anaesthetic area. There can be more than one lesion sometimes. The peripheral nerve closest to the area involved is usually thickened. The lesion can continue to enlarge and there is irreversible loss of skin appendages, i.e hair follicle, sweat glands as well as cutaneous receptors (Fig. 26.7).

**Indeterminate Leprosy:** This is the earliest clinically detectable stage from which most patients will pass. There is a skin lesion, which is a single hypopigmented macule of 2–4 cms size with minimal anaesthesia. A high index of suspicion in close contacts of leprosy patients is required to diagnose this stage. In majority, this lesion may heal without any treatment while in some it progresses to other forms of the disease.

**Borderline Leprosy (BL):** Features, which do not clearly belong to either TL or LL and are ill-defined, are taken as borderline leprosy. There can be three further subdivisions borderline tuberculoid (BT), borderline (BB), or borderline lepromatous (BL). There can be shift from one category to the other depending upon host and bacterial factors, which change the clinical picture.



Fig. 26.7: Hypopigmented patch in tuberculoid leprosy

**Lepromatous Leprosy:** The initial skin lesions are a macule or diffuse skin infiltration. Later they progress, become papular and nodular, and innumerable and confluent. The characteristic facial features – Leonine facies, loss of eyebrows and distorted earlobes develop. There may be accompanying anaesthesia and later peripheral sensory neuropathy which may go on to deformities such as claw hand, dropped foot, inversion of the feet and claw toes. Trophic ulcerations follow with loss of peripheral tissues, such as the nose or digits.

**Reactional states:** Changes in the immunological balance between host and bacteria especially on treatment can cause following acute clinical reactions:

- **Type I (reversal) reactions:** Acute pain and swelling of existing skin and neural lesions occurs. The acute neuritis can cause irreversible nerve injuries, e.g. facial paralysis, foot drop, and claw hand. The skin lesions ulcerate and can leave severe scars. This results from a sudden increase in cell-mediated immunity and is seen predominantly in BL. Type I reactions are a medical emergency requiring immediate treatment.
- **Type II reactions (Erythema Nodosum Leprosum (ENL)):** This reaction is seen in lepromatous leprosy or BL. The skin nodules become red and tender resembling erythema nodosum. There is accompanying fever, polyarthralgia, tender lymphadenopathy and splenomegaly. This is caused by a systemic inflammatory response to the immune complexes.

## Diagnosis

Anaesthetic skin lesions are pathognomonic of leprosy. A skin biopsy from an active lesion provides confirmation.

**Table 26.8:** Daily paediatric doses for leprosy

Dapsone	1 mg/kg
Rifampicin	10 mg/kg
Clofazimine	1 mg/kg

To classify patients for treatment categories, slit and smear preparations are made. The disease is classified as Paucibacillary if there are <5 skin lesions and no bacilli on smear; multibacillary if >6 skin lesions with bacilli on smear. No other investigations are required.

**Treatment**

There are three compounds, which have shown efficacy in treatment of Leprosy. The earliest one, Dapsone (since 1940) is the most important and frequently used. Rifampicin is a rapid bactericidal drug and the third is clofazimine. Multi drug therapy is recommended to prevent resistance and a high cure rate. As per WHO recommendations, intermittent (weekly/monthly) directly observed treatment is given and the doses for this are higher than daily therapy. The duration of treatment for paucibacillary ranges from 6 months to 1 year and for multibacillary 1–2 years (Table 26.8).

With adequate treatment the prognosis is good but the irreversible changes in skin and nerves remain. For prevention, BCG, the tuberculosis vaccine, has been found to give 50% protection with a single dose and more with second dose.

**SYPHILIS**

**Aetiology**

The causative organism for syphilis is *Treponema pallidum* from spirochaetaeae family.

**Epidemiology**

Syphilis is either an acquired infection or transmitted transplacentally. The acquired infection occurs most commonly through sexual contact with an infected person and very infrequently through blood or blood products.

A pregnant woman who is in either primary or secondary stage of syphilis or less often while in latent stage transmits congenital syphilis.

**Clinical Features**

**Congenital Syphilis:** The transplacental transmission rate of syphilis is almost 100% with fetal loss in little less than half of the pregnancies. If the baby is born alive then he goes through early and late signs of congenital syphilis. The infant may be

**Table 26.9:** Late signs of congenital syphilis

Olympian brow	Periosteitis of frontal bone and bony prominence of forehead
Higoumenakis sign	Unilateral or bilateral thickening of the sternal head of clavicle
Saber shins	Anterior bowing of tibia
Hutchison's teeth	Peg shaped upper central incisors
Mulberry molars	Excessive cusps in lower molar
Saddle nose	Depressed nasal root
Rhagades	Linear scars around mouth
Juvenile tabes	Spinal cord involvement
Clutton Joints	Unilateral/bilateral synovitis of lower limb joints especially knee
Interstitial keratitis	

asymptomatic at birth or develop early manifestations. One of the characteristic presentations is a maculopapular rash along with hepatosplenomegaly, lymphadenopathy and bone involvement in the form of osteochondritis and periosteitis leading to pseudo-paralysis. There can be involvement of any of the systems like CNS, renal and gastrointestinal. Late signs of syphilis appear after the first 2 years of life and are primarily related to involvement of the bones and CNS involvement (Table 26.9).

**Diagnosis**

- Direct examination for *T. pallidum* under dark field microscopy from any lesion is diagnostic.
- Serological tests
  - Non-treponemal serological tests
    - VDRL (Venereal disease research laboratory test)
    - RPR (Rapid plasma regain test)
  - Treponemal serological tests
    - TPI: Treponema immobilization test
    - FTA-ABS Fluorescent Treponemal antibody absorption test
    - MHA-TP: Micro haemagglutination assay for antibodies *T. pallidum*

The treponemal antibody tests in congenital syphilis have to be interpreted in context of the maternal antibody titers. (If the infant's titer decreases by 3–6 months, it confirms transplacentally transferred maternal antibodies). If initial titers of non-treponemal serology are 4 times more than the maternal levels, it indicates an infected infant. An infected placenta indicated by a large size and histological changes showing endovascular and perivascular arteritis, proliferative villitis is additional evidence of fetal infection.

**Treatment**

An infant showing early signs of congenital syphilis has to be treated completely. In an asymptomatic infant with maternal

history of syphilis or positive VDRL, treatment is indicated if:

- Untreated or inadequately treated mother
- A non-treponemal serology titer of 4 fold or greater than maternal levels in the infant.

The drug of choice is inj. Crystalline penicillin 1 lac (=100,000 units)/kg per day IV in 12 hourly doses for 7 days and then 8 hourly doses for 7 days.

## LEPTOSPIROSIS

Leptospira are aerobic spirochetes occurring worldwide. It is the most widespread zoonotic disease. There are more than 200 pathogenic sero-varieties of Leptospira with clinically overlapping presentations.

### Epidemiology

Most of the cases occur in tropical and subtropical areas. Leptospira infects many species of animals but rat has been the principle source of infection for man. Pets especially dogs can also infect if good hygiene is not maintained. Leptospira cause disease in animals as well. The animals excrete the bacteria in urine and contaminate surface water and soil from which infection travels to humans.

### Pathogenesis

The portal of entry for leptospira is usually a break in skin like abrasions or mucous membranes. The leptospira after entry into the blood stream, spread to various organs and get lodged in liver, kidneys or CNS for a long time. The primary pathology seen is damage to the endothelial lining of small blood vessels.

### Clinical Features

Leptospiral infection can be asymptomatic or a mild illness or a typical biphasic illness with severe organ dysfunction and death. The incubation period is 7–12 days. The initial phase of blood stream invasion is called septicemic phase and lasts 2–7 days. During this time the child has fever with chills, headache, vomiting and myalgia. Lymphadenopathy and hepatosplenomegaly may also occur. The septicemic phase may be followed by a brief asymptomatic period and followed the immune phase. The immune phase is characterized by appearance of antibodies to leptospira while the organism itself disappears from circulation and is present in the organ systems. This phase can last for several weeks. There is a recrudescence of fever and depending on the extent of the organ involvement; the clinical presentation can be variable. Neurological involvement is seen as meningo-encephalitis and neuropathies. Liver involvement is generally a severe disease with jaundice and elevation of enzymes (Weil's disease). Renal dysfunction can range

from abnormal urinalysis, azotaemia to acute renal failure. Hemorrhagic manifestations and circulatory collapse are uncommon manifestations.

### Diagnosis

During first week, leptospira can be cultured but requires prolonged period for same. Dark field microscopy of blood (1st week) and fresh urine (2nd week) may show leptospira. Serological tests (a) Microscopic agglutination test is the specific test but difficult to do as involves live cultures of leptospira. (b) ELISA test – tests IgM antibodies and is positive early in disease. (c) Slide agglutination test.

### Treatment

Penicillin is the drug of choice especially if given early. Inj. crystalline penicillin IV 6–8 million units/m<sup>2</sup> per day is given in 4 divided doses for 1 week. For hypersensitive patients the alternative is tetracycline.

## MEASLES

Measles, also known as Rubeola, occurs worldwide and is an important cause of childhood morbidity and mortality.

### Aetiology

Measles is caused by an RNA virus belonging to Paramyxoviridae family, genus morbillivirus. There is only one serotype known.

### Epidemiology

Measles has been identified to occur in history for a long time. Epidemics have occurred in various parts of the world. With the widespread use of measles vaccine, the epidemiology has changed. The unimmunised children of all ages are susceptible. Infants younger than 6–9 months have protective antibodies transferred from their mothers transplacentally and hence are protected. As the measles vaccination coverage is increasing, it has been suggested that the transplacental antibodies of vaccine-immunized mothers may protect the infant for a lesser time.

Measles is a highly contagious disease with secondary attack rate as high as 90% among susceptible close contacts. The infection occurs through droplets and there are no other hosts or vectors. The period of infectivity is 5 days before and 4 days after the appearance of rash.

### Pathogenesis

The measles virus enters the body via respiratory epithelium causing a viraemia and then lodges in the reticulo-endothelial system. A second phase of viraemia occurs infecting various organs. There is an inflammatory reaction in the



**Figs 26.8A and B:** (A) Erythematous maculopapular rash of measles (B) Post-measles brownish pigmentation

mucosa of respiratory tract with exudation and proliferation of mononuclear cells. An interstitial pneumonitis can result—Hecht giant cell pneumonia. The intestinal tract is also involved and there can be hyperplasia of lymphoid tissue especially in appendix where multinucleated giant cells (Warthin-Finkeldey cells) are seen. The skin rash (exanthema) of measles is accompanied by a similar reaction (enanthem) in the mucosa characteristically seen as Koplik spots in buccal mucosa. Enantheams occur in the mucosal lining of respiratory and gastrointestinal systems also.

### Clinical Features

Three clinical stages have been described in measles including the incubation period, which is of 10–12 days duration. This is followed by the 2nd stage or the prodromal period. During this the child has cough, coryza, conjunctivitis and the pathognomonic Koplik spots. Koplik spots are seen on buccal mucosa opposite lower molar and appear as pale white or greyish tiny dots over reddish mucosa. They are seen for 1–2 days only. The conjunctival inflammation initially has a characteristic erythematous line at the lid margin but later becomes more diffuse. The 3rd stage, the stage of rash is heralded by a sudden rise of fever to 40°C or even higher and the appearance of rash. The erythematous, maculopapular rash first appears behind ears, along hairline and neck, spreads to face, arms and chest within 24 hours (Fig. 26.8A). Rash spreads further to abdomen, back and lower limbs. As it starts appearing on feet, it begins to fade from the face and downwards in the order of appearance. The whole stage takes 3–4 days. The fever drops to normal as the rash reaches the lower limbs. Persistence of fever indicates a secondary bacterial infection. The measles rash on fading leaves a branny desquamation

and a brownish pigmentation, which persists for 2 weeks or more (Fig. 26.8B). The clinical appearance of rash can vary from mild to confluent and completely covering the body. Occasionally there can be a hemorrhagic rash (Black Measles) and this may be accompanied by bleeding from other sites as well.

Involvement of reticulo-endothelial system is apparent clinically as enlargement of lymph-nodes in the neck, splenomegaly and abdominal pain due to mesenteric lymphadenopathy.

### Diagnosis

No investigations are required to diagnose measles in a typical case. In doubtful cases, measles IgM antibody can be estimated. Paired sera (acute and convalescent phases) estimation will be more reliable.

### Differential Diagnosis

See Table 26.10.

### Treatment

The mainstay of treatment is supportive therapy. Maintaining adequate hydration and nutrition are important. Antipyretics and tepid sponging for high fever and humidification for relief of cough should be given. There are no specific antiviral drugs for measles.

### Complications

- Respiratory complications: Secondary bacterial infection can cause otitis media and other upper respiratory system involvements. Interstitial pneumonitis can occur due to measles virus itself. Secondary bacterial pneumonia or viral infections are also common.
- Myocarditis is an infrequent occurrence.
- Gastrointestinal complications: Acute diarrhoeal disease is a common complication especially in developing countries. Due to decreased immunity, dysentery can also occur.
- Neurological complications: Measles infection has been associated with various types of encephalomyelitis, as listed below
  - Early encephalitis like picture thought to be due to direct viral invasion of the CNS.
  - A later post-measles encephalitis due to demyelination, may be an immunological reaction.
  - Chronic encephalitis-subacute sclerosing panencephalitis.
  - In addition, other neurological complications like Guillain-Barré syndrome, retro-bulbar neuritis can also occur.

Table 26.10: Differential diagnosis of exanthematous fever

Features	Measles	German measles	Roseola infantum	Scarlet fever	Meningococcaemia	Kawasaki disease	Drug rash	Dengue fever
Prodromal illness	Catarrh, conjunctivitis cough, Koplik spots, fever	Mild Catarrh	Mild respiratory symptoms	None	Respiratory symptoms	None	None	None
Onset of rash	Preceding fever x 3-4 days, onset with high fever, rash along hair-line, cheeks	Preceded by lymphadenopathy, rash begins on face, minimal fever	After 3-5 days of high fever and as fever resolves, rash appears on trunk	Within 1-2 days of fever, around neck	No definite pattern with fever	After about 1 week of fever	Related to the drug	After 1-2 days of defervescence
Spread of rash	Face, neck, trunk and limbs in 2-3 days	Spreads quickly	Spreads to neck, face and limbs	Spreads to trunk and limbs, face is spared	No typical order of spread	No pattern	No specific pattern	Spreads to whole body may spare palms and soles
Type of rash	Erythematous maculopapular	Erythematous maculopapular with flushing	Discrete, raised, pink lesions 2-5 mm	Finely, papular, erythematous sand paper feel	Erythematous maculopapular	Any type	Any type	Erythematous morbilliform or maculopapular
Fading of rash	Fever subsides, rash fades in order of appearance leaving branny brownish discoloration	Fades in 3 days, minimal desquamation	Fades in 1-3 days	Fade after 3-4 days with extensive desquamation	No pattern	No pattern	Depend on withdrawal of drug	Fades 1-2 days
Associated features	Respiratory symptoms	Tender lymphadenopathy	Febrile seizures are common	Respiratory symptoms, strawberry tongue	Sepsis, DIC, shock petechiae, purpura	Bulbar conjunctival injection, lymph-adenopathy swelling of hands, feet	Itching	Body aches, leucopenia thrombocytopenia
Diagnostic investigation	None	None	None	Throat swab culture group A streptococci	Culture positive for meningococci	With drawal of drug relieves the rash	Dengue serology	

- Ocular involvement can cause keratitis and corneal ulceration
- Skin infection can cause gangrene of cheeks known as Noma.
- Malnutrition
- Flaring of underlying pulmonary tuberculosis

Subacute sclerosing panencephalitis (SSPE): It is also known as Dawson encephalitis occurs due to persistent measles virus in CNS. It is a rare disorder occurring worldwide. The onset generally occurs at 5–15 years of age. A higher risk has been seen for measles infection occurring at a younger age, for boys and children from rural or poor socio-economic background.

The pathological picture shows necrosis and inclusion body panencephalitis picture. It has an insidious onset with behavior changes or declining school performance. This is followed by myoclonic jerks and there may be frank seizures also. Cerebellar ataxia and other abnormal movements may also be seen. There is progressive dementia, stupor and coma. The course is variable ranging from few months to few years (1–3 years).

Diagnosis is by demonstrating IgG and IgM measles antibodies in CSF. The gamma globulins are markedly elevated in CSF. There are no diagnostic EEG or MRI pictures of SSPE. Treatment is symptomatic and supportive. Prognosis is poor as there is slow progression of the degenerative process.

## MUMPS

Mumps is an acute viral infection of the salivary glands.

### Aetiology

Mumps virus, with only one serotype, is an RNA virus from paramyxoviridae family.

### Epidemiology

Mumps is known to occur worldwide. Unimmunised children are at risk. The mode of transmission is airborne droplets or contaminated fomites. There is no other reservoir of infection. The infective period extends from 24 hours before the appearance of swelling to 3 days after it has subsided.

### Clinical Features

A little less than half of the infections by mumps virus are subclinical. The incubation period is 2–4 weeks. The prodromal features are minimal. The primary manifestations of mumps are related to salivary glands. Parotid salivary gland is the most commonly involved structure. The glands swell and increase in size to obliterate the angle of jaw (mandible) and reach the ear, which gets displaced upwards

and outwards. The gland is tender with pain in the ear and also on salivation. The opening of Stensen's duct near the upper molars may show redness and oedema. The involvement of parotid glands may be unilateral or bilateral. The submandibular salivary glands are affected less frequently. There is swelling and tenderness in the submandibular area and the Wharton's duct opening is inflamed. Sublingual salivary glands are still less commonly involved. There can be accompanying low-grade fever. The swelling of the salivary glands subsides in a week's time.

### Differential Diagnosis

- Other viruses causing parotitis e.g. influenza and parainfluenza, coxsackie, CMV, HIV
- Bacterial parotitis
- Salivary calculus
- Cervical lymphadenitis.

### Diagnosis

Viral confirmation of a diagnosis of mumps depends on isolation of the virus or the demonstration of a significant rise in antibody titre during the illness.

### Treatment

No specific treatment is indicated and only supportive treatment is required. Analgesics/antipyretics for pain and fever can be given.

### Complications

- CNS complications are the most frequent in children.
  - Aseptic meningitis
  - Mumps encephalitis
  - Post infectious demyelination encephalitis
  - Aqueduct stenosis and hydrocephalus
- Orchitis and Epididymitis: Commonly seen in adolescents or adults. This may follow salivary gland involvement by a week or so. There can be bilateral orchitis. The symptoms of fever, vomiting and lower abdominal pain with testicular swelling and pain last for about 4 days. In 1/3 cases affected testis may undergo atrophy. Infertility is rare.
- Oophoritis in post pubertal females is seen.
- Pancreatitis
- Myocarditis
- Arthritis
- Sensorineural deafness

### Key Learning Points

- ➔ CNS involvement in mumps can precede parotitis
- ➔ Mumps rarely causes sterility in males.

**Case Study**

A 4-year-old partially immunised child was hospitalised with fever for 3 days, seizures and altered sensorium for one day. Systemic examination was normal except for positive meningeal signs and altered sensorium. A diagnosis of acute meningoencephalitis was made. CSF examination showed pleocytosis of 400 WBCs/cumm with 50% lymphocytes and 50% polymorphs and normal sugar and protein levels. Over the next few days in hospital, the child developed a tender swelling over the left parotid region indicative of parotitis.

*Diagnosis:* Mumps with meningoencephalitis

**RUBELLA**

Rubella or German measles is a milder viral infection as compared to measles. The major clinical significance of rubella is in the transplacental transmission to the embryo and fetus from an infected mother leading to congenital rubella syndrome.

**Aetiology**

Rubella virus, the causative agent, is an RNA virus from the family *Togaviridae*.

**Epidemiology**

As with measles, human is the only host for rubella virus. It has a worldwide presence. The route of usual infection is through droplet except for congenital rubella. It is also highly contagious with outbreaks occurring in hostels or institutions with closed environment. The period of infectivity is from 7 days before the rash to 7 days after the disappearance. Even subclinical cases can be a source of infection.

**Clinical Features**

The incubation period of 14–21 days is followed by a prodrome of mild catarrhal symptoms, which are of short duration. Before the appearance of rash, the typical tender lymphadenopathy of rubella is seen. The posterior auricular, post cervical and post occipital groups of lymph nodes are involved. The lymphadenopathy can last up to 1 week. The rash begins on face and spreads fast to the rest of the body, generally within 24 hours and then fades in the next 1–2 days leaving minimal desquamation. The fever may be absent or low grade.

**Diagnosis**

Confirmation of the diagnosis, if required, is by serology and sometimes by cultures. Haemagglutination inhibition (HI) antibody test, EIA, fluorescent immunoassay have been found to be sensitive tests.

**Table 26.11:** Features of congenital rubella

General	CNS
IUGR	Meningoencephalitis
Skin rashes—blueberry muffin	Mental retardation
	Microcephaly
Eyes	CVS
Cataracts	Myocarditis
Micro-ophthalmia	Patent ductus arteriosus, pulmonary artery stenosis
Ears	Haematological
Sensorineural hearing loss	Anaemia
Others	Thrombocytopenia
Pneumonia	
Hepatitis	

**Treatment**

Only supportive treatment is required.

**Complications**

Unlike measles, few complications occur. A rare progressive rubella panencephalitis similar to SSPE has been described.

**Congenital Rubella Syndrome**

Active infection during pregnancy can lead to transplacental infection of the embryo or fetus depending upon the gestation. The risk is greatest (90%) during first trimester and decreases to 70% in 2nd and lesser in 3rd trimester. The fetus develops intrauterine growth retardation. The virus infects all the organs (Table 26.11). The diagnosis is confirmed by rubella IgM antibodies in the neonate or by isolating the virus, as it is present in the tissues and nasopharynx. It is excreted in urine for one year or more. The outcome of congenital rubella is highly unfavourable as disease can progress even after birth.

**VARICELLA VIRUS (CHICKENPOX)**

Varicella zoster virus is responsible for two clinical entities chickenpox and herpes zoster (shingles).

**Aetiology**

Varicella virus belongs to human herpes virus group.

**Epidemiology**

Varicella has a worldwide distribution and is almost a universal infection. Prior to vaccination, by 15 years of age, most of the children were infected with less than 5% remaining susceptible especially in temperate climates. In warmer climates, there may be a shift to older age infection. It is a highly contagious disease with high secondary attack rates. The source of infection is either droplet or contact with the lesion fluid. The



period of infectivity is 1–2 days before the rash and till all the lesions have crusted. There is usually no asymptomatic infection although the disease may be very mild in young children. Herpes zoster is caused by reactivation of the virus, which has become latent after the primary infection. It is uncommon in children and is a milder disease in childhood.

### Pathogenesis

The varicella virus enters the respiratory epithelium where it multiplies and causes viraemia. A second viraemic phase occurs during which the cutaneous lesions appear in crops. The virus enters the sensory ganglia and becomes latent there. The subsequent reactivation of this leads to herpes zoster rash and the neurological features.

### Clinical Features

Chickenpox is a febrile exanthematous illness. The incubation period is 10–21 days following which prodromal symptoms of fever, malaise, and headache may occur for 1–2 days. The fever can rise to 104–106°F. The rash starts from face or trunk as erythematous papules. It evolves through the stages of clear fluid filled vesicles, which then become pustules and finally there is crusting of the lesions. The evolution can take 1–2 days. Fresh crops of rashes keep erupting and at a time in the illness one can find all stages of the rash (Fig. 26.9). The rash has a centripetal appearance with more lesions in the trunk. The palms and soles are also involved, as are oropharynx and vagina. There is intense itching of the lesions. By the end of 1 week, usually most lesions are scabbed. The scabs fall off leaving faint scars, which usually disappear.

### Diagnosis

The classical skin lesions help in making the diagnosis on clinical basis. There may be leucopenia for few days. Liver enzymes also show transient elevation.



Fig. 26.9: Polymorphic lesions of chickenpox

### Treatment

In healthy children with mild disease only supportive treatment is recommended. There is a specific and safe antiviral drug, Acyclovir, available. It can be given safely to children in the dose of 20 mg/kg per dose as 4 doses per day for 5 days. The earlier it is started the better is the efficacy in limiting the spread of the disease and eliminating the virus. If Acyclovir is given 3 days or later after the onset of rash, it may not be effective in preventing further spread of the disease. Varicella-zoster immunoglobulin (VZIG) is recommended for those who are at increased risk of severe varicella e.g. neonates and immunosuppressed patients.

### Complications

- Thrombocytopenia
- Cerebellar ataxia
- Varicella encephalitis
- Pneumonia
- Nephritis/Nephrotic syndrome
- Haemolytic uraemic syndrome
- Secondary bacterial infections.

**Herpes Zoster:** In Herpes zoster, the skin rash is similar to chickenpox but has the characteristic dermatomal distribution and the vesicles can coalesce to become large bullae. The rash is accompanied by pruritus, pain and hyperaesthesia. Unlike adults, post-herpetic neuralgia is not common in children. Immunocompromised children, e.g. with HIV infection, tend to have severe zoster disease and may even have recurrent episodes. Oral acyclovir is effective in Herpes zoster.

**Neonatal Chickenpox:** Neonatal chickenpox can be a severe disease with high mortality. It occurs if the baby is born within a week of onset of maternal varicella rash, as the virus will pass to the baby. If maternal illness occurs more than 1 week before delivery the maternal antibodies may form and protect the neonate. Neonatal varicella requires vigorous treatment with IV acyclovir and zoster immune globulin.

**Varicella fetopathy:** Varicella fetopathy has been described if maternal infection occurs before 20 weeks of gestation. A number of malformations can occur. There are cicatricial skin lesions with limb defects and damage to eyes and CNS.

#### Key Learning Points

- ⇒ All types of skin eruptions, i.e. papules, vesicles and pustules are seen at one time in chickenpox.
- ⇒ Lesions are infective till completely scabbed.

## POLIOMYELITIS

Poliomyelitis is an acute viral illness caused by poliovirus and has a wide spectrum of presentation ranging from a mild disease to acute flaccid paralysis. It is covered in the chapter on Diseases of Nervous System –see Chapter 18.

## RABIES

Rabies, a viral infection of warm-blooded animals, has been known to occur for a very long time and finds mention in ancient texts.

### Aetiology

The rabies virus belongs to the Rhabdoviridae family and is an RNA virus.

### Epidemiology

Rabies virus is present in the susceptible animals throughout the world. Although dogs are the most well-known vectors, there are many other animals, which transmit rabies including bats, skunks, raccoons, foxes and cats. With the vaccination of pets becoming widespread, other animals are becoming an important source of infection. In areas with substantial population of stray animals, the virus remains in circulation. The main source is the virus shedding in the saliva by the infected animal. The incubation period in the dog ranges from 2 weeks to 6 months. The shedding of virus occurs only 3–6 days before visible symptoms. The viral shedding may be variable and only less than half of bites from proven rabid animals result in rabies. Claw scratches by animals are also considered dangerous as they lick their paws and leave the virus there. Human to human transmission has not been reported except for transplants from infected individuals.

### Pathogenesis

After the bite, the virus enters the skeletal muscles, multiplies and enters the nerves, ascends along the axons to the spinal cord and eventually brain causing neuronal destruction. The areas involved include medulla, pons, brainstem, floor of the fourth ventricle, hippocampus, thalamus and basal ganglia. Characteristically the cerebral cortex is spared. The typical Negri bodies are cytoplasmic inclusions of the virus in the neurons. These can be absent in proven cases. The combination of brainstem encephalitis with an intact cerebral cortex is seen in rabies only.

### Clinical Features

The incubation period of human rabies is extremely variable. The usual is 20–180 days but the extremes have been 9 days and 7 years. There may be a prodrome of non-

specific symptoms for the first week before entering the acute neurological phase. The neurological illness can be of two types, the furious variety seen in 80% of cases or the paralytic variety in 20%.

**Furious Rabies:** The pathognomonic sign of this is hydrophobia. It is presumed to be occurring due to an inspiratory muscle spasm secondary to destruction of brainstem neurons inhibiting the nucleus ambiguus controlling inspiration. Whenever the patient attempts to swallow liquids, there is possible aspiration into the respiratory passages leading to a respiratory muscle spasm. With this reflex spasm even the sight of water causes distress to the patient. A similar response is seen to the air currents fanning the patient – Aerophobia that is another pathognomonic sign. Along with these two characteristic signs, there are behavioural changes in the form of disorientation, violent behaviour and there may be seizures. The patient may have brief lucid intervals.

**Paralytic Rabies:** There is an ascending, symmetrical flaccid paralysis.

### Differential Diagnosis

The classical signs of rabies help in differentiating from encephalitis due to any other cause. The paralytic rabies may be mistaken for other causes of acute flaccid paralysis like Guillain Barré syndrome or poliomyelitis.

### Diagnosis

Rabies virus can be isolated from saliva, conjunctival epithelial cells or skin cells at the hairline. The method used can be fluorescent antibody stain or reverse transcriptase PCR. These tests can be done on the brain tissue also after the death of a patient.

### Treatment

There is no specific treatment for rabies. After the onset of neurological symptoms rabies immunoglobulin also do not help. WHO has given guidelines on post exposure prophylaxis (Table 26.12).

## JAPANESE ENCEPHALITIS

### Aetiology

Japanese encephalitis (JE) is caused by an RNA virus from flaviviridae family and is an arbo-viral disease.

### Epidemiology

JE as the name suggests was reported from Japan in late 19th century and the virus identified in early 20th century. It has also been called Japanese B encephalitis to differentiate from another type of viral encephalitis called type A. The

**Table 26.12:** Guidelines for post-exposure treatment of rabies

Category	Type of contact with suspect/confirmed domestic/wild animal/animal unavailable for observation	Recommendations
1.	Touching or feeding of animals, Licks on intact skin	None if reliable history is available
2.	Nibbling of uncovered skin	Administer vaccine immediately. Stop treatment if animal remains healthy throughout an observation period of 10 days or if animal is killed humanely and found to be negative for rabies by appropriate laboratory techniques.
3.	Single or multiple bites or scratches. Contamination of mucous membrane with Saliva (i.e. licks)	Administer rabies immunoglobulin and stop treatment if animal remains healthy throughout an observation period of 10 days, or if animal is killed humanely and found to be negative for rabies, by appropriate laboratory techniques.

Exposure to rodents, rabbits and hares seldom, if ever, requires specific anti-rabies treatment. If an apparently healthy dog or cat, in or from a low risk area is placed under observation, the situation may warrant delaying initiation of treatment. This observation period applies only to dogs and cats. Except in the case of threatened or endangered species, other domestic and wild animals suspected as rabid should kill humanely and their tissues examined using appropriate laboratory techniques.

distribution of JE is mainly in the eastern part of the world, i.e. Japan, Korea, China, Philippines, Indonesia and the Indian subcontinent. The vector for this arbo-virus is a mosquito, *Culex tritaeniorhynchus* that usually bites large animals and birds or humans at night time. *Culex vishnui* is another related species of mosquito, which spreads the disease in India. As mosquito population is closely related to seasonal changes so JE outbreaks also follow the seasonal pattern.

### Clinical Features

The incubation period of 4–14 days is followed by four stages of JE.

Prodromal Stage	2–3 days
Acute Stage	3–4 days
Subacute	7–10 days
Convalescence	4–7 weeks

The illness starts with a sudden onset of fever accompanied by respiratory symptoms and headache. This is soon followed by some behavioural changes like disorientation, delirium or excessive sleepiness. Seizures of generalized variety may occur in one fourth of patients. The neurological signs fluctuate from hyperreflexia to hyporeflexia, intention tremors and cogwheel rigidity. Patient may progress to

coma. A rapid progression of disease is often seen in young children with high fatality.

### Diagnosis

The CSF shows pleocytosis (100–1000/cumm) with initial polymorph predominance followed by lymphocytosis. Confirmation of the diagnosis can be by checking for specific IgM antibodies in the serum or CSF early in the illness or an increase of IgG antibodies in paired sera. EEG shows diffuse slowing. Cranial MRI/CT may show white matter oedema and hypodense lesions in thalamus, basal ganglia and pons.

### Treatment

There is only supportive treatment.

### Prognosis

Mortality is high especially in children. Neurodevelopmental sequelae are frequently seen in survivors.

## DENGUE FEVERS

Dengue fevers comprise a group of febrile illnesses caused by arthropod borne viruses (Arbo-viruses) including Dengue hemorrhagic fever and Dengue shock syndrome.

### Aetiology

The dengue viruses belonging to family flaviviridae have four distinct antigenic types. In addition, there are a few other arbo-viruses, which cause a similar clinical picture.

### Epidemiology

The principal vector for all dengue viruses is a mosquito, *Aedes aegypti*. Other *Aedes* species have also been reported to carry these viruses. At present the disease is endemic to areas, which have suitable breeding environment for the specific mosquito. Hence it is the tropical areas like Asia, Africa, Caribbeans and South America, which have majority of cases. Explosive outbreaks of dengue occur in urban areas where *A. aegypti* is breeding. This mosquito lives in areas where stored or pooled water is collected and is a day biting mosquito. The biting rates increase with increase in temperature and humidity. The mosquito does not have a wide flight range so the outbreaks and epidemic are usually due to viraemic humans travelling to different areas.

### Pathogenesis

The exact pathogenetic mechanism for the diverse clinical presentations of dengue fevers is not yet known. No single characteristic pathological change has been noticed in the autopsy of patients dying with dengue. It has been observed that a second exposure or infection by the dengue viruses

is more likely to lead to a significant disease. There are infection-enhancing antibodies formed as a result of first infection, which on second exposure cause higher degree of viraemia and consequently a more severe disease. The second infections activate the complement system and there are many factors, which together interact to produce increased vascular permeability. This allows fluids to move from intra to extravascular spaces leading to haemoconcentration and hypovolaemia.

The mechanism of bleeding in dengue hemorrhagic fever is not exactly clear. It may be a combination of factors like thrombocytopenia, DIC and liver damage. The cause of thrombocytopenia is also not well established. There is a maturational arrest of megakaryocytes in bone marrow. Other mechanisms like antibodies on platelet surface or cross-reacting antibodies have also been considered.

### Clinical Features

The incubation period of dengue fever is 1–7 days. The clinical presentation can be variable.

There may be an initial flu-like illness for few days or a sudden rise of temperature even up to 106°F. There is accompanying frontal headache and retro-bulbar pain with severe myalgia and arthralgia. There may also be severe backache before the fever. A transient erythematous rash may also appear early in the febrile phase. Towards the end of first week of illness, there is a typical cutaneous hyperaesthesia and hyperalgesia with marked loss of appetite and taste. As the fever comes down, there is a second phase of rash, which is generalized, erythematous with morbilliform or a lacy appearance. There can be accompanying diffuse oedema especially of palms and soles. The rash lasts 1–5 days followed sometimes by desquamation and intense itching. There may be a slight fever also at this stage. In some patients there is thrombocytopenia and neutropenia with variable bleeding manifestations ranging from epistaxis to menorrhagia. The platelet count can drop to 10,000 / cu.mm and WBC count to even 1000/cu.mm. Usually the patient makes a quick recovery in 2–4 days.

**Dengue haemorrhagic fever (DHF):** The initial mild onset of dengue fever may rapidly change its course towards rapid deterioration after 2–5 days. The patient appears ill with flushed and cold extremities, restlessness and has bleeding from venipunctures or spontaneous petechiae and ecchymoses. There is significant hepatomegaly. Few patients may have gastrointestinal bleeding also.

**Dengue shock syndrome (DSS):** In few patients, the DHF may be complicated by a shock like state due to the accompanying hypovolaemia (Leaky capillaries) and also bleeding.

Some patients have significant extravasations into pleural spaces (pleural effusion, unilateral or bilateral) as well as

ascites. The liver involvement occasionally can be clinically manifested as mild icterus also. After 1–2 days of critical illness, the patient can make a quick recovery with return to normal temperature, blood pressure and pulse. There is reabsorption of the intravascular fluid. During this phase, careful attention to fluid intake and balance is required as patient may develop congestive heart failure. There have been few reports of dengue encephalitis also in children similar to other viral encephalitis.

### Differential Diagnosis

A clinical suspicion in the setting of dengue fever endemicity is usually used to make a diagnosis. As there are other viruses causing similar diseases, the term Dengue like disease should be used in the absence of specific diagnosis. WHO has given guidelines for diagnosing DHF/DSS.

### WHO Criteria for DHF/DSS

#### DHF

- Fever
- Minor/major haemorrhagic manifestations
- Thrombocytopenia < 100,000/cu.mm
- Increased capillary permeability (increase in hematocrit of >20%)
- Pleural effusion (X-ray chest)
- Hypoalbuminaemia

#### DSS

- DHF criteria Plus
- Hypotension
- Pulse pressure < 20 mmHg.

### Diagnosis

Complete blood counts including hematocrit and platelets will show the already mentioned changes. Liver function test may show elevation of enzymes, hypoproteinaemia and prolonged prothrombin time. Chest radiographs show pleural effusion in many patients.

Specific virological investigations are based on serological tests or virus isolation. In dengue infection first episode IgM levels rise for 6–12 weeks but in second infection IgG rise is much more. Fourfold rise in paired sera help in diagnosis. A single serum sample for antibodies collected at least 5 days after the onset and up to 6 weeks can also be used.

### Treatment

Supportive treatment especially during the critical period of illness is most essential. Bed rest and antipyretics during the febrile period are used. Adequate fluid intake must be ensured. Close monitoring is required for further progression

into DHF/DSS. For patients with significant bleeding manifestations and thrombocytopenia, platelet transfusions as well as blood transfusions are required. For patients in shock rapid intravenous fluid, normal saline bolus is given. If there is persistent shock or haemoconcentration, colloids in the form of plasma are indicated.

#### Case Study

A 13-year-old boy was hospitalised with a history of fever with body ache for one week, generalised rash, and epistaxis on the day of admission. On examination he had a low-grade fever, a generalised morbilliform erythematous rash and a few petechiae on limbs. He had tachycardia otherwise examination of respiratory and cardiovascular system was normal. There was hepatomegaly on abdominal examination. Investigations: Hb 14 gm/dl, Total white cell count 3,000/cumm, P45%, L42% M5%, E3%, Platelets 20,000/cumm.

*Diagnosis:* Dengue fever.

## HUMAN IMMUNODEFICIENCY VIRUS INFECTION (AIDS)

Infection with human immunodeficiency virus (HIV) is one of the recently identified diseases. The first case of HIV infection in paediatric age group was reported in 1983. HIV infection eventually leads to acquired immunodeficiency syndrome (AIDS), a disease with a very high mortality.

### Aetiology

HIV virus is of two types, viz. HIV-1 and HIV-2. They are both RNA viruses of family Retroviridae. HIV-2 is a rare cause of infection in children.

### Epidemiology

According to WHO year 2005 estimates, 38,600,000 persons are living with HIV or AIDS. Out of these children comprise about 6%. The sub-Saharan Africa, South East Asian countries like India, Thailand, Vietnam and China dominate the picture. In children, >90% of infection is through vertical transmission, i.e. from mother to child. A small percentage is through blood or blood products and transmission through sexual contact or IV drug use seen in the adolescent age group.

**Perinatal transmission:** In HIV positive women, the perinatal transmission rates can vary from 16-40% if no protective measures are undertaken. The risk factors for higher rates of transmission are advanced maternal HIV disease, delivery <37 wks, prolonged rupture of membranes, vaginal delivery, chorioamnionitis, invasive procedures (e.g. amniocentesis) and haemorrhage in labour. The transmission of infection can occur any time during

pregnancy or intrapartum period. In utero transmission can occur as a transplacental infection or through inflammation of the membranes or by materno-fetal transfusion. With early infection fetal loss is more likely. The most frequent timing of transmission of infection is intrapartum (60–75%) and occurs through materno-fetal transfusion. Post-partum transmission can occur through breastfeeding. The risk of HIV transmission to baby from breast milk ranges from 12–14%. The risk is higher in babies on mixed milk feeding as compared to exclusive breastfeeding.

### Pathogenesis

The first cells to be infected through mucosal entry of HIV are the dendritic cells. These cells transport the virus to the lymphatic tissues where it selectively invades the CD4 lymphocytes, monocytes and macrophages.

After infecting CD4 cells there is progressive viral replication followed by a viraemic phase 3–6 weeks after infection. This is associated with flu like symptoms sometimes. Subsequently there is a decline in the viraemia due to the normal immune response of the body. CD8 cells are of help in containing the initial infection. A variable period of clinical latency follows but during this phase viral multiplication continues. The cytokines play an important role in sustaining viral load during this phase.

Following perinatal transmission of infection, there is little evidence clinically or virologically of HIV infection at birth. The viral load increases after first month and viral isolation by laboratory tests is more likely to be positive between 1–4 months of age. The immunological abnormalities in HIV infected children are similar to changes in adults except that as there is physiological lymphocytosis hence the values for labelling CD4 depletion are different in children. There is also B cell activation leading to an increased antibody production and resultant hypergammaglobulinaemia.

### Clinical Features

After perinatal transmission, there are three types of clinical presentation described. The first presentation is of rapid progression where the infant presents with features of AIDS in first few months of life. There is a rapid deterioration with poor survival beyond first year of life. Majority of the children have the second type of presentation. The child is asymptomatic during initial 1–2 years and later presents with lymphadenopathy, failure to thrive and other features of AIDS. The median survival in this pattern is about 6 years. The third pattern is of a delayed presentation, which is seen infrequently. The child has no significant features till 8–10 years of age followed by full AIDS presentation.

The usual presenting features in developing countries are chronic or recurrent diarrhoea, failure to thrive

and wasting. There may be accompanying chronic or recurrent mucocutaneous candidiasis, lymphadenopathy and hepatosplenomegaly. In infants the initial presentation may be a severe respiratory distress due to *Pneumocystis carinii* infection. CNS involvement is also more common in children. The symptoms have been categorized by CDC as shown below.

### Staging of Paediatric AIDS [Centres for Disease Control (1994) Criteria]

#### Category N

Asymptomatic, no signs or symptoms or only one of the conditions listed in Category A.

Category A: Mildly symptomatic or two or more of the following conditions.

- Lymphadenopathy
- Hepatomegaly
- Splenomegaly
- Parotitis
- Dermatitis
- Recurrent or persistent upper respiratory infection.

Category B: Moderately symptomatic conditions attributed to HIV infection.

- Severe bacterial infections
- Lymphoid interstitial pneumonia
- Anaemia
- Neutropenia
- Thrombocytopenia
- Cardiomyopathy
- Nephropathy
- Hepatitis
- Diarrhoea
- Candidiasis.

Category C: Severely symptomatic, two serious bacterial infections.

- Encephalopathy (acquired microcephaly, cognitive delay and abnormal neurology)
- Opportunistic infections (*Pneumocystis carinii* pneumonia, cytomegalovirus, toxoplasmosis, disseminated fungal infections)
- Disseminated mycobacterial diseases
- Cancer (Kaposi's sarcoma, lymphomas).

### ASSOCIATED INFECTIONS

As HIV causes serious disturbances in immune system, associated infections are almost universal and very often the presenting feature. Any organism bacteria, viruses, protozoa or fungi can cause serious systemic sepsis in HIV infected children. Opportunistic organisms are also frequent causes

of serious disease in such children. Various opportunistic infections are listed below.

### Opportunistic Infections

*Pneumocystis carinii* pneumonia  
Candidiasis—oesophageal or pulmonary  
Tuberculosis  
*Mycobacterium avium*  
Cytomegalovirus  
Cryptosporidiosis  
Non-tuberculous mycobacteria  
Herpes zoster  
Toxoplasmosis.

*Mycobacteria* and HIV share a symbiotic relationship in HIV infected patients. Both tuberculosis as well as non-tuberculosis mycobacteria, can cause difficult to treat, disseminated and resistant disease.

Candidial infections also occur in a more widespread fashion often involving oesophagus along with oral cavity. Out of viruses, Herpes group, both zoster and simplex are frequent offenders.

### Diagnosis

If any one of the parents is known to be having HIV infection, the infant/child must be screened for it. In others, the indications for HIV testing are given below.

In asymptomatic children:

- Parent at high risk for HIV infection, e.g. truck drivers, IV drug users.
- Children receiving transfusion or blood products, etc.

In symptomatic infants and children:

- Recurrent, severe bacterial infections
- Opportunistic infections
- Poor response to antitubercular treatment
- Evidence of congenital TORCH infection
- Unexplained wasting, neuroencephalopathy, myopathy, hepatitis, cardiomyopathy, nephropathy
- Hyperimmunoglobulinemia.

Viral cultures are the gold standard for diagnosis of HIV and have 100% specificity. The culture requires 2–3 weeks, is labour intensive and expensive. The alternative, PCR for viral DNA or RNA, is also specific and sensitive. The assay for p24 antigen of HIV has also been frequently used with good specificity but less sensitivity.

### PERINATAL TRANSMISSION

At birth all infants born to HIV positive mothers have placentally transferred antibodies. These decline slowly in 6–12 months time. Only at age 18 months or more, if the antibody test is positive that can be used as an indicator of

infection in the child. In a neonate born to an HIV positive mother virological assay (PCR/culture/p24 antigen) provide reliable results. If anti-retroviral therapy is to be started, it is recommended that testing should be done within 48 hrs of birth, at 4–6 weeks of age and or 4–6 months of age. Two positive tests from different samples confirm the transmission of HIV infection to the infant. On the other hand if two different tests of which one should be at 4–6 months of age are negative then HIV infection can be excluded. At 18 months age, in an asymptomatic infant, two negative antibody tests exclude HIV infection.

### Older Infants and Children

In older infants and children, two or more HIV antibody tests done by different techniques on different samples are recommended to make a diagnosis. Once HIV infection is diagnosed in a child further evaluation is done by complete blood count along with CD4 and CD8 lymphocyte counts. Additional tests depend on the extent and type of systemic involvement.

### Treatment

At present the available antiviral drugs suppress the virus and help in making the disease less aggressive. There are two broad categories of antiviral drugs, viz.

- Protease inhibitors (PI), e.g.
- Reverse transcriptase inhibitors which are further classified as nucleoside (NRTI) or non-nucleoside (NNRTI), e.g.

The basic principle of anti-retroviral treatment is combination therapy with 2 NRTI + PI or 2 NRTI + 1 NNRTI. Monotherapy is only used in prevention of perinatal transmission. Initiation of therapy in HIV infected asymptomatic children needs appropriate consideration. In symptomatic children or in those with evidence of immunosuppression treatment is definitely indicated.

### Supportive Treatment

Attention must be paid to the nutrition of child; frequent evaluation of growth and development is necessary. All vaccinations except live attenuated ones can be given safely. In asymptomatic infants live vaccine may also be given. In all infants and in immunosuppressed children, *Pneumocystis carinii* prophylaxis with cotrimoxazole must be given. Frequent screening for tuberculosis must be done.

### Prevention

Prevention of perinatal transmission of HIV is a unique opportunity for protecting the infant. One of the standard regimens is to give zidovudine to the pregnant woman

and continue through intrapartum period followed by 6 weeks therapy in the infant. Recently oral Nevirapine, an NNRTI, has been used effectively for reducing the perinatal transmission. It is given as a single oral dose to the mother during labour followed by a single oral dose to the neonate within first 48 hours. This strategy has been effective in the developing countries as Nevirapine is inexpensive and only two oral doses are required. It has been adopted as a National program in India. In addition to anti-retroviral therapy in mother, caesarean section and preventing prolonged rupture of membrane are also helpful in reducing transmission.

Breastfeeding can be responsible for up to 14% risk of HIV transmission but the decision to breastfeed or not must be taken after discussion with the mother regarding implications of giving animal milk. Mixed feeding, i.e. breast + animal milk should be avoided. If breastfeeding, then at 3 months of age an early and abrupt weaning is recommended.

For prevention in adolescents, sex education and awareness especially regarding condom use must be propagated.

## MALARIA

### Aetiology

Intracellular protozoa, Plasmodium, cause malaria. There are four species of plasmodium that infect humans viz *P. vivax*, *P. falciparum*, *P. malariae* and *P. ovale*. Female anopheles mosquitoes transmit it during a blood meal on humans. It can also be a transfusion transmitted infection or a transplacental infection from mother to the fetus.

### Epidemiology

Malaria occurs worldwide but the endemicity depends on the mosquito population. In areas with suitable environment for mosquito breeding, the incidence of malaria is high, e.g. Africa, Asia and South America. *P. falciparum* and *P. vivax* are more commonly seen in sub-Saharan Africa and Indian subcontinent. *P. ovale* is rare and seen mainly in Africa. *P. malariae* is the rarest.

### Pathogenesis

Plasmodia have two parts of their life cycle, sexual and asexual phase, in vector mosquito and human host respectively. In the humans there are two stages. First stage in the liver, the exoerythrocytic phase and the second one in RBCs, the erythrocytic phase. Mosquito bites the human host and releases sporozoites in the blood stream, which quickly enter the hepatocytes. In the hepatocytes the sporozoites multiply, become schizonts and rupture the cell. On rupture of hepatocytes, thousand of merozoites

are released into the circulation. *P. vivax* has two types of schizonts, a primary type, which follows the above cycle, and a secondary type, which becomes dormant in the hepatocytes for weeks and months causing frequent relapses. The merozoites released into the circulation enter the RBCs and become the ring form, which later grows to become trophozoite. The trophozoite multiplies again and gives rise to merozoites in RBCs, which rupture releasing them in circulation. The release of merozoites is associated with a sharp rise in fever. Some of the merozoites develop into male and female gametocytes, which are ingested by the female anopheles mosquito during a blood meal. The gametocytes undergo the sexual phase of development in the stomach of the mosquito where a zygote is formed and develops into sporozoites, which enter the mosquito salivary glands ready to inject the new host.

In the pathogenesis of malaria, fever results from RBC rupture and release of merozoites. The other common feature, anaemia, is a result of breakdown of RBCs, i.e. haemolysis. There are two more mechanisms responsible for other clinical features. An immunopathological process leading to release of cytokines, which cause many features. In *P. falciparum*, another pathological change is the adherence of infected RBCs to the endothelial lining of blood vessels. This results in damage to various organs like brain, kidneys, intestines, etc.

## Clinical Features

Incubation period for each species is different (Box 26.1)

### Box 26.1: Incubation period of malaria species

• <i>P. vivax</i>	12-17 days
• <i>P. falciparum</i>	8-14 days
• <i>P. malariae</i>	18-40 days
• <i>P. ovale</i>	16-18 days

The onset of the disease is marked by a sudden rise of fever, which may be periodic. Rigors and sweating, headache, body ache, nausea and vomiting accompany the fever. There may be diarrhoea and cough also sometimes. The gastrointestinal and respiratory symptoms are seen more often in young children and infants. After a few days of fever, the patient begins to appear pale and may even have jaundice. In adults there is a definite periodicity of fever, which is generally not seen in children. The clinical presentation in some children may be different with low-grade fever, hepatosplenomegaly, anaemia and thrombocytopenia.

Congenital malaria is considered in a neonate whose mother was symptomatic during late pregnancy. The neonate may manifest with symptoms between 10–30 days of age. The neonate may or may not have any fever along with poor feeding, lethargy and vomiting. Unexplained anaemia and

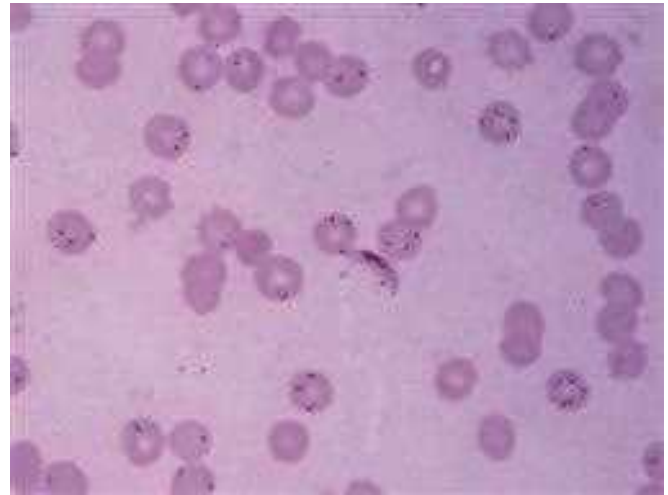


Fig. 26.10: Ring forms and gametocytes of *Plasmodium falciparum*

severe jaundice (indirect hyper-bilirubinaemia) are additional features.

Black water fever is a severe form of falciparum malaria with haemolysis, hemoglobinuria and severe anaemia. The mortality can be high with this presentation of malaria.

Algid malaria is a severe infection with *P. falciparum*. There is hypotension, shock, shallow respiration, and pallor with a rapid fatality. Gram-negative sepsis is often associated.

## Diagnosis

Peripheral blood smear, thin and thick smear, should be examined. From the thick smear the diagnosis can be made more quickly while thin smear helps in identifying the species and the parasitic load. Several smears over different days may be required to confirm the diagnosis (Fig. 26.10).

The newer diagnostic tests include an antibody test as well as a PCR. A test based on malarial antigen has also been available for some-time although sensitivity and specificity are still a problem.

## Complications

- **Cerebral Malaria:** *P. falciparum* causes this serious life-threatening complication especially with a heavy parasitaemia. The child presents with high fever even up to 108°F (hyperpyrexia) accompanied by alteration of sensorium, coma, twitching and seizures. There may be retinal haemorrhages and neurological deficits also. The CSF does not show any significant abnormality except for raised pressure. Cerebral malaria is associated with high mortality and requires intensive treatment at the earliest possible.
- **Renal failure** may occur due to haemoglobinuria and tubular damage.



## Infectious Diseases

- Hypoglycaemia
- Thrombocytopenia
- Splenic rupture may occur if spleen is greatly enlarged or there is trauma.

### Treatment

All Plasmodium species are treated with oral Chloroquine phosphate 10 mg base/kg (maximum: 600 mg base) then 5 mg base/kg (maximum: 300 mg base), 6 hr later, and 5 mg base/kg per 24 hr (maximum: 300 mg base) at 24 and 48 hr. Parenteral drug of choice if required is Quinine dihydrochloride 20 mg/kg loading dose over 4 hrs, then 10 mg/kg over 2–4 hrs q8 hrly (max. 1200 mg/24 hrs) until oral therapy can be started. In areas of known Chloroquine resistance Quinine sulfate Plus Tetracycline or plus Pyrimethamine-sulfadoxine combination is given. Another alternative is Mefloquine hydrochloride

### Prevention of Relapses (For *P. Vivax* and *Ovale* only)

Primaquine phosphate in the dose of 0.3 mg base/kg per 24 hr for 14 days (maximum: 15 mg base) should be given. Primaquine phosphate can cause haemolytic anaemia in patients with glucose-6-phosphate dehydrogenase (G6PD) deficiency. A G6PD screening test should be performed before initiating treatment.

Along with specific treatment, the child may need additional fluids during acute stage. In a severe case, anaemia needs attention. Haematinics to bring up the haemoglobin should be given on recovery. Preventive measures for mosquito breeding as well as from bites must be reinforced.

#### Case Study

An 8-year-old girl was brought to the paediatric service with a history of fever for 4 days, which went up to 104°F accompanied, by a feeling of chills. She also had mild cough and vomiting. Examination showed pallor and no jaundice. Examination of abdomen revealed a mild hepatomegaly of 3 cms while spleen was enlarged to 4 cm and was firm in consistency. Rest of the systemic examination was normal. Investigations: Hb 9 gm/dl, Total leucocyte count 5,400/cumm, P 60%, L 40%. Peripheral smears showed Plasmodium vivax schizonts.

*Diagnosis:* Malaria caused by *P. vivax*.

#### Key Learning Points

- ➔ Malaria can cause respiratory and gastrointestinal symptoms in young children
- ➔ *P. vivax* and *P. ovale* require a radical cure to eradicate the exoerythrocytic phase.

## TOXOPLASMOSIS

Toxoplasmosis is a disease with many varied presentations. It occurs in neonates as a transplacental infection and in immunocompromised older individuals. Healthy immunocompetent persons rarely manifest clinical disease.

### Aetiology

The causative organism is an intracellular protozoa, *Toxoplasma gondii*. The infection occurs after ingesting oocysts, which may be present in the contaminated foodstuff especially infected meat. The oocysts are released in the environment by cats in their faeces. Cats acquire the infection after ingesting mice infected with encysted bradyzoites of *T. gondii*.

### Epidemiology

*T. gondii* occurs as a latent infection among humans throughout the world with a higher prevalence in warmer, humid area. The route of infection is by ingestion of contaminated meat containing oocysts or transplacental or transfusion transmitted. There is no direct person-to-person transmission. The oocysts ingested by cats undergo schizogony and gametogenesis in the intestines and form sporocysts, which are excreted in the faeces and remain viable in a suitable environment for 1 year. They can be destroyed by drying, boiling or by some strong chemicals. Other animals, e.g. sheep, pigs and cows become infected by ingesting the cysts and develop viable tissue cysts in muscles and brain. Humans eating partially cooked or uncooked meat of these animals ingest these cysts.

Congenital toxoplasmosis occurs in case mother acquires the infection during pregnancy. In the first trimester, the likelihood of transmission is low but the resultant fetal infection is severe. In 3rd trimester, almost 65% of fetuses are infected but the disease is either mild or inapparent.

### Pathogenesis

*T. gondii* can multiply in any mammalian tissue. They cause necrosis and an immunological reaction. In healthy persons, the tachyzoites soon disappear from tissues to become latent. They cause characteristic changes in lymph nodes. In congenital toxoplasmosis, CNS, eyes, heart, lungs, liver, spleen and muscles can be involved with the necrotic lesions.

### Clinical Features

Majority of healthy individuals do not have any clinical features. Occasionally, there can be features ranging from fever, myalgia, CNS involvement, rashes, lymphadenopathy which may be present for a variable period of time.

Lymphadenopathy can wax and wane for 1–2 years. One of the frequently caused presentations is of chorioretinitis.

Congenital infection can present as intrauterine growth retardation, prematurity, prolonged jaundice. The classical triad is of chorioretinitis, hydrocephalus and cerebral calcification. Severe manifestations include hydrops fetalis and perinatal death. The infants with inapparent infection often present with ocular involvement later in life.

## Diagnosis

*T. gondii* can be isolated from body fluids or from tissues. Cultures are done by inoculating into mice or tissue cultures. The tachyzoites of *T. gondii* can be demonstrated in bone marrow aspirates, CSF, amniotic fluid or in biopsy specimens.

Serological testing: A number of serological tests are available for toxoplasmosis. It is important that these tests have appropriate quality control measures. Some of the tests used are:

- Sabin-feldman dye test
- IgG or IgM indirect fluorescent antibody test
- Double sandwich ELISA
- Polymerase chain reaction (PCR).

## Treatment

All congenitally infected infants need treatment. The treatment of choice is Pyrimethamine given for 1 year along with sulphadiazine or triple sulphonamides. Acutely infected pregnant women should be treated with spiramycin to prevent transplacental fetal infection.

## AMOEBIASIS

### Aetiology

Amoebiasis is caused by *Entamoeba histolytica*. There are few non-pathogenic *Entamoeba* also which are present in the gastrointestinal tract of human beings, e.g. *Entamoeba coli*.

### Epidemiology

Amoebiasis is more commonly seen in tropics and in areas of low socioeconomic status with poor sanitation. It is estimated that amoebiasis is the third leading parasitic cause of death worldwide. The transmission is through feco-oral route. The cysts of *E. histolytica* are the infectious form while the trophozoites do not transmit infection. The amoebic cysts are nucleated. They are resistant to low temperature and chlorination of water. On ingestion, they are resistant to gastric acidity and the digestive enzymes. Trophozoites succumb to the environmental factors.

### Pathogenesis

After ingestion, the amoebic cysts reach the small intestine and give rise to eight trophozoites, which are actively

motile and reach the large intestines. In the colon, they attach to the mucosa and cause tissue destruction by various cellular products. This leads to ulceration of the mucosa but surprisingly there is little local inflammatory response. The organisms spread laterally from the ulcerated areas causing further destruction and leading to the typical 'flask-shaped' ulcers. The trophozoites invade liver also producing similar lesions but again with no inflammatory reaction.

## Clinical Features

The spectrum of amoebic disease varies from asymptomatic carriers to severe intestinal or extra intestinal disease. More severe disease is likely in young or malnourished children and those on corticosteroid therapy.

Symptomatic intestinal amoebiasis: The symptoms of intestinal amoebiasis can occur anytime after infection and even an asymptomatic carrier can develop invasive disease later on. The presentation starts with abdominal colic, loose stools with or without blood, tenesmus and occasionally there may be fever. In young children, the onset can be of more acute colitis with dehydration and dyselectrolytaemia. Chronic amoebiasis is more commonly seen in adults.

Systemic or extra intestinal amoebiasis: Liver can be affected in amoebiasis as a diffuse hepatitis like picture with hepatomegaly. The more severe and less common is formation of an amoebic liver abscess, which is seen in <1% of infected persons. The abscess is usually in the right lobe and single. There may be a history of associated intestinal symptoms. The presentation is with high fever, abdominal pain and tender hepatomegaly. There may be reactionary changes in the adjacent right lung or pleura. The abscess can rupture into the abdominal or thoracic cavity. The contents of the abscess are characteristically described as 'anchovy sauce' and contain lysed RBCs.

## Diagnosis

Detection of the amoebic trophozoites in stool sample is diagnostic. A fresh stool sample, i.e. within 30 minutes of passage can show motile trophozoites with ingested RBCs. Repeated stool examination, at least 3, increase the yield. Serological tests are helpful in diagnosis but may be positive in asymptomatic carriers also. Indirect haemagglutination is the most sensitive serological test.

## Treatment

The treatment of intestinal disease is with luminal amoebicides viz. Iodoquinol, Paromomycin and Diloxanide furoate. All persons including asymptomatic carriers should receive treatment. In extraintestinal disease or invasive colitis, tissue amoebicides are used. These include Metronidazole and other related compounds, Dihydroemetine and Chloroquine. Metronidazole is given in the dose of 30–50 mg/kg per d in

3 divided doses for 10 days. For giving dehydroemetine, the patient has to be hospitalised. Chloroquine is concentrated in the liver and considered useful for liver abscess. Surgical management of liver abscess is recommended if there is a poor response after a week of treatment with amoebicidal drugs.

**Case Study**

A 10-year-old boy was hospitalised with a history of high-grade intermittent fever for one week, pain in abdomen for 4 days. He had diarrhoea for about 2–3 weeks previously. On examination, he was mildly icteric, pale, febrile and sick looking. His vital signs were stable. On chest examination, the movements and breath sounds were diminished in the right lower zone but there were no adventitious sounds. Abdomen had an enlarged, tender hepatomegaly of 8 cms in midclavicular line. There was no splenomegaly. Hepatic punch was positive. Investigations: Hb 9 gm/dl, TLC 20,000/cumm, P80%, L20%, blood film showed normocytic, normochronic anaemia. Serum liver function tests were abnormal. Ultrasonography of abdomen showed a large 6 × 8 cms abscess in right lobe of liver near the dome of diaphragm with restricted mobility of diaphragm.

Needle aspiration of the abscess revealed chocolate brown thick fluid.

*Diagnosis:* Amoebic liver abscess.

no prior exposure to giardia the presentation can start as acute diarrhoea. In another manifestation, the child may have intermittent diarrhoea, which is accompanied by abdominal cramps, distension, flatulence and loss of appetite. There may be features of increased gastro-colic reflex. The stools become greasy and foul smelling. There are no blood, mucus or pus cells in stools. Chronic giardiasis can present as malabsorption with significant weight loss.

**Diagnosis**

Demonstration of giardia cysts or trophozoites in stool sample is diagnostic. A fresh stool sample (within 1 hour of passage) is more likely to be positive and repeated examinations are helpful. In some cases, if necessary, duodenal aspirates or a biopsy can show the trophozoites.

**Treatment**

A number of drugs are effective for treating giardiasis. Albendazole in a dose of 10 mg/kg per day for 5 days is safe and effective. It is also helpful in treating mixed infection, as it is an antihelminth also. Tinidazole is effective in a single dose of 50 mg/kg. Metronidazole, Furazolidone, Quinacrine are other drugs that are used.

**GIARDIASIS**

**Aetiology**

*Giardia lamblia* is a flagellate protozoon, which causes primarily an intestinal infection. Giardia cysts are infective in even small numbers.

**Epidemiology**

Giardiasis is the commonest intestinal parasitic infection the world over. It is more common in areas of poor sanitation and hygiene and in institutionalised children. Drinking contaminated water is a frequent source of infection but other foodstuffs can also transmit infection. The cysts are resistant to chlorination and ultraviolet radiation but boiling inactivates them.

**Pathogenesis**

After ingestion, the cysts produce trophozoites, which colonize the duodenum and jejunum. They attach to the brush border of the intestinal epithelium and multiply there. The trophozoites pass to intestines and are encysted to form the cysts, which are then excreted in the stools.

**Clinical Features**

The incubation period is usually 1–2 weeks but can be longer. Most infections may remain asymptomatic. In children with

**Case Study**

A 7-year-old child had history of recurrent diarrhoea for 6 months. The stools were pale yellow foul smelling, greasy and did not contain blood or mucus. He had abdominal pain off and on and an urge to pass stool after every meal. He had lost weight and looked pale. There were no other findings on examination. A fresh stool examination showed trophozoites of *Giardia lamblia*.

*Diagnosis:* Giardiasis.

**Key Learning Point**

➔ Giardiasis can cause a clinical presentation similar to malabsorption syndrome. Examination of fresh stool or duodenal aspirate confirms the diagnosis.

**KALA AZAR (VISCERAL LEISHMANIASIS)**

Leishmania are a group of organisms causing diverse diseases transmitted by sandflies. There are a number of species, which cause cutaneous or mucosal disease and also visceral disease.

**Aetiology**

Leishmania are protozoa belonging to trypanosomatidae family. They have two morphological forms, a flagellate organism in the insect known as promastigote and the aflagellate form in the humans, amastigote.

## Epidemiology

Leishmaniasis occurs in most parts of the world except Australia and Antarctica. The various types of leishmaniasis are specific to the regions of the world. *Leishmania* causing cutaneous disease does not cause visceral involvement. *Leishmania* enters the vector sandfly and changes from promastigote to an infective stage and migrates from the gut to mouth of the sandfly. From the mouth they are inoculated into the host during a blood meal. In endemic areas, leishmanial cycle is continued as a zoonosis with humans being incidental hosts. The reservoir for visceral forms is dog.

## Pathogenesis

*Leishmania* after inoculation into the host, enters the macrophages. Inside the macrophages, the promastigote form change to amastigote form and start multiplying. They rupture the cell to infect more macrophages.

## Clinical Features

The children may have an asymptomatic infection. Some children develop a symptomatic illness with fever, malaise, fatigue accompanied by a mild hepatomegaly. In all but few this resolves spontaneously. In few it progresses slowly over weeks and months to Kala azar. There is intermittent fever, weakness and splenomegaly. As the disease progresses fever becomes higher, there is weight loss and hepatosplenomegaly. The patient has severe anaemia and may develop heart failure due to this. Oedema and jaundice are also present. As spleen becomes massive, features of hypersplenism in the form of thrombocytopenia and pancytopenia develop.

## Differential Diagnosis

The conditions causing pyrexia with hepatosplenomegaly, anaemia are to be considered in differential diagnosis of visceral leishmaniasis.

## Diagnosis

Amastigote forms, also known as *Leishmania donovani* (LD) bodies, are found intracellularly in tissues like liver, spleen and bone marrow. A positive bone marrow or spleen aspiration for LD bodies provides confirmation of diagnosis (Fig. 26.11). An ELISA test using a recombinant antigen also has high sensitivity and specificity.

## Treatment

The specific treatment for visceral leishmaniasis has remained unchanged for more than four decades. Pentavalent antimony compounds, sodium stibogluconate is given as 20 mg/kg per day IV/IM for 3–4 weeks. Complete recovery can take a few months and sometimes even repeated courses. Recently,

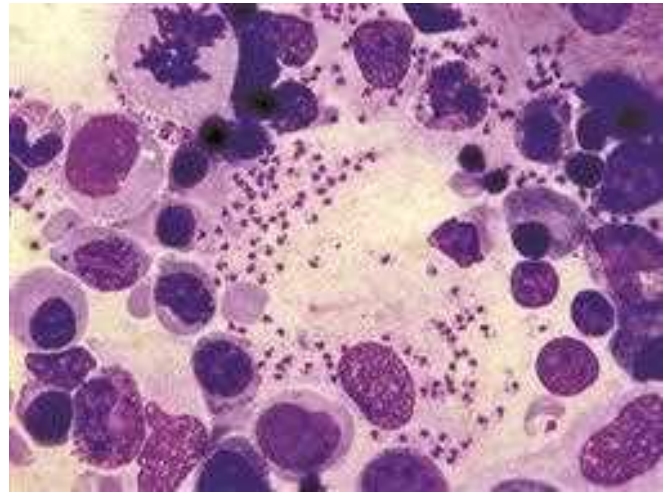


Fig. 26.11: *Leishmania donovani* (LD) bodies seen in bone marrow

Amphotericin B especially liposomal variety, has been shown to be highly effective even among those refractory or resistant to antimony compounds. Pentamidine has also been used but higher doses and prolonged treatment is required.

In addition, supportive treatment to improve nutritional status is important. In cases with severe pancytopenia, blood component therapy may prove life-saving.

### Case Study

A 9-month-old girl was admitted to a children's hospital, with a 10-day history of lethargy, pallor, fever, and poor feeding. On examination she was found to have a mass in the left hypochondrium. She was febrile and miserable. Her Hb was 65 g/l, white cell count  $6.3 \times 10^9/L$ , and platelets  $41 \times 10^9/L$ . Initially she was thought to be suffering from a malignant condition and was investigated accordingly. Bone marrow examination, blood culture, chest radiography, skeletal survey and urine catecholamines were all normal. Abdominal ultrasound examination showed the mass to be a massively enlarged spleen.

She was given a blood transfusion and antibiotics after which her general condition improved, although she continued to spike a fever two to three times a day. By the third day after admission, the results of the above investigations were all negative and the possibility of visceral leishmaniasis was raised. The child had been on holiday to an endemic area where leishmaniasis is known to occur. The bone marrow examination showed the presence of *Leishman Donovani* bodies. Also *Leishmania* serology became positive five weeks after presentation.

She was treated with sodium stibogluconate 20 mg/kg per day for 10 days followed by 10 mg/kg per day for another 10 days. Her temperature settled within two days of starting treatment. Her platelet count returned to normal within seven days and by the 10th day of treatment her white cell count reached normal values. She made an uneventful recovery.

*Diagnosis:* Visceral leishmaniasis.

# Paediatric Ophthalmology

## VISUAL ASSESSMENT IN CHILDREN

A child's eye is different from that of an adult. It is a growing eye, with the most rapid growth taking place within the first 2 years of life. Astigmatism is often present during the first few months of life, and most infants are hypermetropic, becoming normal sighted (emmetropic) during the first few years of life.

- The developing immune system results in children responding to inflammation and to other disease conditions differently from adults.
- Myelination of the optic nerve and maturation of the fovea continue after birth, as does pigment deposition in the anterior iris stroma.

### Visual Acuity

Visual acuity is a measure of the clarity of central vision. It is defined as the measurement of the resolution of the visual system in terms of the angle subtended at the fovea by an object at a distance of 6 metres from the eye, tested at maximum contrast (black on white).

- In clinical practice, quantification of visual acuity is required to diagnose abnormality, to chart progress of disease and to determine the results of treatment.
- Standard visual acuity measurement in ophthalmology has traditionally been performed using the Snellen chart. 6/6 is a normal visual acuity. The numerator of this fraction is the distance in metres at which the letters are shown to the patient, and the denominator is the distance at which that letter being read subtends 5 minutes of arc at the eye. The 6/60 letters at the top of the chart therefore subtends 5 minutes of arc at a distance of 60 metres. In the USA the numbers used refer to feet, so that 6/6 acuity is the same as 20/20 acuity.
- An alternative and arguably more logical way to record visual acuity is the logMAR notation in which 6/6 is an acuity of 0.1 and 6/60 becomes 1.0 with eight intervening

- In infants and young children, such methods are not feasible, but quantification of visual acuity is obtained using different methods (below), and equivalent scales of measurement.

### Amblyopia

Visual development takes place from birth until the age of 6–7 years, and requires clear visual images to be formed on the retina of each eye.

Amblyopia occurs when there is deficient development of the visual brain due to impaired stimulation of the fovea during the first few years of life. This may occur due to the presence of uncorrected refractive error, squint (deviation of the eye such that the image formed on the retina is extrafoveal, i.e. falls on an area of retina other than the fovea), or any type of occlusion in front of the retina including media opacities (cataract, vitreous opacity, blood or inflammatory cells in the anterior chamber), corneal opacity or abnormal eyelid position (ptosis).

#### Box 27.1: Types of amblyopia

- Refractive
- Strabismic
- Stimulus deprivation

Iatrogenic causes of amblyopia may include prolonged use of eye ointment, or of eye padding following injury or surgery to an eye. Prolonged pupil dilatation may also be amblyogenic. The retina appears normal, but visual acuity is reduced. If detected before the age of 7–8 years, amblyopia may be partially or wholly reversible by treating the underlying cause. Amblyopia is usually unilateral or asymmetrical, and occlusion of the better eye (taking care not to induce amblyopia in that eye!) is used to bring about adequate retinal stimulation of the eye with poorer vision (once the refractive error or media opacities etc. have been dealt with) in order to overcome amblyopia. It is, therefore,

determining vision in young children of different age groups. Appropriate measures for treatment of amblyopia can then be instituted promptly.

### Assessing Vision

There are several key factors to be considered when assessing vision in young children.

- Young children are neither in a position to understand “normality” of visual ability, nor can they articulate what they can or cannot see.
- A “difficult” examination of a child is usually due to a “difficult” examiner rather than a “difficult” child. Entering a child’s mindset, setting them at their ease, and maintaining patience and respect throughout the examination may be a daunting thought for some of us, particularly in the presence of anxious parents. However, it is a skill we ignore at our peril. Once the skill is mastered, or even haltingly attempted, clinic appointments can become something child and examiner alike, look forward to, though fewer are likely to be required, and the final outcome has a much greater likelihood of being successful and satisfying for all parties involved.
- A child’s general demeanour and ability to move around and to communicate is not necessarily a guide to the level of their visual function, as different aspects of general development as well as of visual development, may be impaired in different disease states. A child can have very poor clarity of visual acuity and yet have practically normal mobility.
- Accommodation of the lens is easily stimulated in children and resting accommodative tone is high. Thus, accurate assessment of refractive error must always be performed after full cycloplegia using cyclopentolate or atropine drops.

### Visual Acuity Measurement

Formal visual acuity assessment in children is carried out in the following ways:

- Infants (0–6 months): (1) Preferential looking, (2) VEPs (visual evoked potentials). (3) Watching the child’s visual behaviour, whether she returns a smile and at what distance, (4) VOR (vestibulo-ocular reflex): spinning the child gently to find out what speed is required to make the eyes move to and fro, giving an index of central visual function. Good vision suppresses VOR.
- Toddlers (7 months–3 years): Cardiff acuity cards.
- Pre-School children (3–5 years): Kay’s pictures.
- Primary School children (5–7 years): Sheridan-Gardiner acuity cards or Glasgow Acuity cards, with a card of letters to point to.
- Over 7 years: Log MAR chart or Snellen’s chart (Figs



A

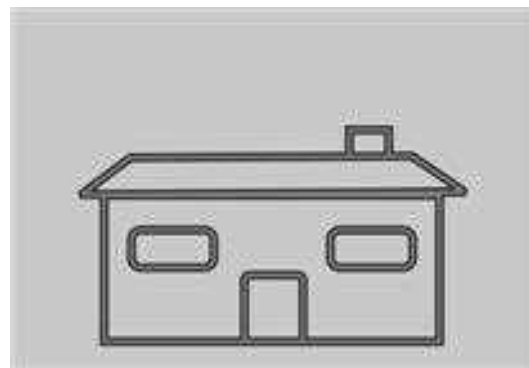


B



C

**Figs 27.1A to C:** (A) Forced preferential looking; (B) Kay’s pictures and (C) LogMAR crowded test



## Assessment of Eye Movements

Orthoptic assessment of ocular muscle balance and the presence or absence of latent or manifest squint is assessed using the cover test (Box 27.2) and the uncover/alternate cover test (Box 27.3). A target of interest or a light moved into the 9 directions of gaze, brought about by the action of the 6 extra-ocular muscles, is then used to examine the adequacy of the muscle actions. Further tests using prism bars are used to record the magnitude and precise type of squint present, and the ability to fuse disparate images.

### Box 27.2: Cover test

One eye is covered and the other eye is observed to see if it moves to look at a target (In the absence of squint, no movement takes place).

In children who look as if they have a squint, the cover test shows:

1. A fixation movement if a true squint is present and the eye can see
2. No fixation movement if:
  - There is a true squint and the eye is blind, for example due to cataract or retinoblastoma
  - The squinting eye is an artificial eye
  - The macula is displaced. This causes the eye to appear to have a squint despite 'fixing' with the macula
  - The image is being viewed with eccentric retina (extrafoveal fixation)
  - The eye is tethered and cannot move. When the eye is uncovered, the other eye is observed, if it moved in the first instance
  - If it moves back immediately, it has poor vision
  - If it keeps looking, but moves back after blinking, it has reduced vision
  - If it keeps looking, and does not move back, it has equal vision to the other eye.

In children who look as if their eyes are straight, the cover test may reveal:

1. A very small angle squint (The uncovered eye moves slightly to take up fixation)
2. Latent nystagmus (a to and fro movement of the eyes which only occurs when one eye is covered).

### Box 27.3: The uncover/alternate cover test

This test is done when the eyes have been shown to be straight by the cover test.

One eye is covered, and then observed when it is uncovered. The test is repeated for the other eye. If either eye moves when uncovered, a latent squint (a phoria) is present.

If both eyes see well, the brain can join the images by fusing them (fusion), and this keeps the eyes straight. When an eye is covered, fusion is lost. If that eye has a position of rest which is turned out (exophoria), turned in (esophoria), turned up (hyperphoria) or turned down (hypophoria), then it will do so when covered, but will be seen to straighten up when uncovered

## Other Visual Functions

Colour vision is tested using Ishihara plates for red-green defects, Lanthony plates for blue-yellow defects, or the City University test. The child is asked to trace along, or to point to a particular colour.

Central and peripheral visual fields are assessed manually using a target, a light, or a variable number of fingers held up, in the 4 quadrants of each visual field, while watching the child's attentiveness to the target. The target may be moved in order to map the point at which it comes into view. Older children are able to co-operate with Goldmann perimetry or with automated perimetry. Lesions of the occipital cortex or posterior visual pathways cause homonymous visual field defects in both eyes. Lesions affecting the optic chiasm typically cause a bitemporal hemianopia, while lesions of the anterior visual pathways or the retina, cause non-homonymous, or unilateral field defects.

Binocular depth perception or stereopsis, measured in seconds of arc, is tested using the Titmus fly and randot test, where superimposed images, displaced by varying degrees are viewed through polarised lenses, and, with adequate levels of stereopsis, are identified as 3-dimensional. In children younger than 5 years old, the Lang or Frisby tests, where the child identifies an elevated image in a group of otherwise identical images, are used. As in the Titmus test, image disparity is graded in order to quantify the level of stereopsis achieved.

Refractive error is measured using retinoscopy and trial lenses (spherical and cylindrical), while singing (at least, the budding performers among us!), or holding up an interesting target, to hold the child's attention.

Contrast sensitivity is not routinely tested in children, but can be useful for monitoring amblyopia and to quantify visual dysfunction.

A child may perform well in all the above tests and yet have significant visual problems in daily life such as difficulty identifying an object in a crowded scene, difficulty recognising faces or route finding, due to impaired visual integration processes at a cerebral level. Such problems occur more commonly than hitherto acknowledged. They are commonly associated with peri-ventricular leukomalacia, which may occur as a consequence of premature birth, antenatal or postnatal cerebral hypoxic episodes, meningitis or head injury. Typical features can usually be elicited by detailed history taking (see check list in Box 27.4), and by an awareness of the typical patterns of disorder, often suggested by symptoms described by a child or their carers.

**Box 27.4:** Check list of visual problems

## Features

## Dorsal stream dysfunction

*Impaired ability to handle complex visual scenes\* can cause difficulties with:*

- Finding a toy in a toy box
- Finding an object on a patterned background (Fig. 27.3)
- Finding an item of clothing in a pile of clothes
- Seeing a distant object (despite adequate acuity)
- Identifying someone in a group
- Tendency to get lost in crowded locations
- Distress in busy shops and crowded places
- Reading.

*Impaired visually guided movement (optic ataxia)*

- Upper limbs: Inaccurate visually guided reach, which may be compensated for by reaching beyond an object then gathering it up.
- Lower limbs: Feeling with the foot for the height of the ground ahead at floor boundaries. Difficulty walking over uneven surfaces (Despite full visual field, and looking down).
- Impaired attention.
- Difficulty 'seeing' when talking at the same time, which may cause a child to trip or bump into obstacles.
- Marked frustration at being distracted.

**Ventral stream dysfunction**

## Impaired recognition

Difficulty recognising people and photographs

Difficulty recognising shapes and objects.

*Impaired orientation*

Tendency to easily get lost in known locations.

**Recommendations****Dorsal stream dysfunction**

- Store toys separately (Figs 27.4 and 27.5)
- Use plain carpets, bedspreads and decoration (Fig. 27.6)
- Store clothes separately in clear compartments. Get close
- Share a zoom video/digital camera view
- Identify through waving and speaking
- Training in seeking and identifying landmarks
- Visit shops when they are quiet
- Determine whether masking surrounding text improves reading ability
- Occupational therapy training.

Provision of tactile guides to the height of the ground ahead. For example pushing a toy pram or holding on to the belt pocket or elbow of an accompanying person.

Limit conversation when walking.

Limit distraction by reducing background clutter and background activity. (Performance may be enhanced at the 'quiet table' at school.)

**Ventral stream dysfunction**

- Family and friends introduce themselves and wear consistent identifiers
- Training to identify and recognise identifiers
- Training in tactile, as well as visual, recognition
- Training in orientation.

Reproduced from: Dutton GN, McKillop EC, Saidkasimova S. Visual problems as a result of brain damage in children. Br J Ophthalmol. 2002;86:222-228.



**Fig. 27.3:** Single toy on patterned background: Visual information too complex



**Fig. 27.4:** Group of toys on patterned background: Visual information too complex



**Fig. 27.5:** Toys spaced out on plain background to simplify visual





Fig. 27.6: Single toy on plain background: Good contrast

## Strabismus

Strabismus, or squint, refers to a deviation of an eye due to an imbalance of function of the extra-ocular muscles such that both eyes do not function together. There may be eso- or exo-, hyper- or hypo- deviation, representing convergence, divergence, depression and elevation of the eye respectively. Occasionally, a torsional abnormality is present. Most strabismus in children is concomitant, i.e. similar in magnitude in all positions of gaze. Incomitant strabismus varies in magnitude with gaze in different directions, and is associated with paresis or palsy of the third, fourth, or sixth cranial nerves. The commonest type of strabismus encountered in paediatric practice is a concomitant congenital esotropia, which may not present until 2–3 years of age.

Strabismus may be latent (termed a ‘phoria’) and brought out only by dissociating the two eyes by alternate cover testing, or manifest (a ‘tropia’) even before testing. It may be intermittent or constant, and there may be alternate fixation of each eye or, in large angle esotropia, cross-fixation (in which the child uses the right eye to look to the left and the left eye to look to the right).

Amblyopia is both a cause and a consequence of strabismus, and should therefore be identified and treated as early as possible.

Uncorrected refractive error, particularly hypermetropia in young children, may cause strabismus.

A red reflex should be sought in every child with a squint because conditions such as cataract or retinoblastoma with reduced acuity (with or without amblyopia) can present with squint and may cause a white pupil (leukocoria) (Figure 27.7).

There is a higher incidence of strabismus following premature birth, in individuals with a positive family history of strabismus and in children with other developmental abnormalities.

## Management

On diagnosing strabismus, findings on base-line examination are documented, including the magnitude of the deviation in prism dioptres, enabling comparison with future tests. The



Fig. 27.7: Leukocoria: A white pupillary reflex. Retinoblastoma must be excluded

degree of stereopsis present is also noted as this affects the final prognosis of treatment.

Treatment of strabismus includes the following measures as indicated:

- Accurate refractive correction and ensuring that spectacles fit well, and are worn
- Treatment of underlying causes of amblyopia such as refractive error (as above) or cataract
- Treatment of amblyopia itself (in children under 7–8 years), by occlusion of the other eye, and detailed visual tasks given, such as drawing or reading
- Exercises to strengthen accommodative convergence and fusional range
- Surgery to re-align the visual axes by weakening and/or strengthening the appropriate extraocular muscles by recession or resection of the muscle insertions. Due to the dynamic nature of extra-ocular muscle imbalance, a single surgical procedure may not suffice. Patients and their carers should always be prepared for the possibility of further surgery.

## NYSTAGMUS

Nystagmus in children can be congenital or acquired.

Congenital nystagmus has the following features:

- Onset during the first month of life
- The meridian of the nystagmus is the same in each position of gaze (it is uniplanar)
- The nystagmus tends to be greater on distance fixation and least on near fixation
- There is a position in which the nystagmus is least (the null position)
- There may be a head posture to place the eyes in the null position to optimise vision
- Compensatory head nodding to stabilise the eyes can occur

The causes of congenital nystagmus include:

- Idiopathic motor nystagmus, which may be idiopathic or inherited with dominant or recessive inheritance
- Albinism (look for fair hair, pale complexion, iris transillumination, and macular hypoplasia)
- X-linked ocular albinism (most commonly in boys) (In this condition there is patchy iris trans-illumination, but the hair may be dark coloured and the skin pigmented)
- Congenital stationary night blindness in which there is poor rod photoreceptor function (ask whether the child can see in dark conditions)
- Achromatopsia in which there is rapid fine horizontal nystagmus (ask whether the child is photophobic and sees better in dark conditions than in daylight)
- Optic nerve hypoplasia (look for small optic nerve heads)
- Achiasmia (look for bitemporal visual field impairment)
- Damage in the occipital area of the brain, in particular damage to the white matter (posterior periventricular leukomalacia).

Acquired nystagmus has the following features:

- The key feature is that the pattern of nystagmus is not uniplanar and is different in different positions of gaze
- The causes of acquired nystagmus include loss of vision, tumours in the region of the chiasm and posterior fossa tumours.

### Clinical Assessment of Patients with Nystagmus

History taking seeks a family history and determines whether vision is worse in dark or daylight conditions. A history of premature birth may suggest periventricular leukomalacia.

As in all patients with an eye problem vision is assessed.

The pattern of nystagmus is assessed in each position of gaze. If the nystagmus is uniplanar then it is very likely to be congenital in origin. If it is not, and the pattern of nystagmus is different in different positions of gaze, imaging of the brain must be carried out to seek evidence of organic pathology such as tumours in the region of the chiasm or brainstem.

Eye examination seeks evidence of blinding pathology such as cataract, iris transillumination, macular hypoplasia, optic nerve hypoplasia and optic atrophy.

Investigation by electroretinography detects rod and cone photoreceptor dysfunction. Visual evoked potentials may be delayed and reduced in amplitude if there is pathology affecting the visual pathways or the brain. Brain imaging is carried out if pathology is suspected.

### Management

Vision is optimised by spectacle correction if required for refractive error. Treatable blinding pathology is identified and treated (e.g. cataract). Nystagmus reduces visual

function, which may require appropriate action to be taken to ensure that school material is enlarged or magnified.

## INTRAUTERINE INFECTIOUS DISEASES

Maternally transmitted infections can be remembered by the acronym TORCHES (Toxoplasmosis, rubella, cytomegalovirus, herpes viruses including the Epstein-Barr virus, and syphilis). These infections have a broad range of presentations, from subclinical forms to severe organ damage. Continuous tissue damage can occur throughout life; therefore long-term follow-up is necessary.

### Toxoplasmosis

*Toxoplasma gondii* is an obligate intracellular protozoan parasite. Feline animals are the definitive hosts. Infected rodents, farm animals, birds, and humans serve as the intermediate hosts. Cats shed millions of oocysts in their faeces, and when these oocysts are then ingested by the intermediate host, the cyst wall dissolves releasing actively dividing tachyzoites. These are transported via intestinal lymphatics to various organs. Dissemination occurs to liver, lung, heart muscles and eyes. Once host immunity is established, the organisms transform to bradyzoites contained within tissue cysts. Bradyzoites lie dormant within the tissues of the intermediate host and when conditions are favourable, cause reactivated infection. The stimulus for local reactivation of an infected cyst is unknown. Humans are infected when they ingest oocysts or contaminated meat containing tissue cysts. Other modes of infection are transplacental transmission, organ transplantation and blood product transfusion.

### Clinical Features

Systemic infection is mild and usually goes undiagnosed. Clinical features include fever, headache, sore throat and diffuse lymphadenopathy. If the mother is acutely infected during pregnancy, transplacental transmission can occur. Congenital toxoplasmosis is described as a triad of convulsions, cerebral calcification and retinochoroiditis. If the foetus is infected in the first trimester, the resultant illness may be severe, with microcephaly, seizures and hepatosplenomegaly. Ocular manifestations include retinochoroiditis, often involving the macula, iritis, anterior and posterior uveitis, optic atrophy, strabismus and nystagmus. Infections acquired later in gestation are less severe and may be asymptomatic. Strabismus and poor vision are due to macular scarring, which can be bilateral. Many cases of 'acquired' toxoplasma retinochoroiditis are due to reactivation of a congenitally acquired infection. The active area of retinochoroiditis is often at the edge of an old flat atrophic scar, a so-called satellite lesion.

### Diagnosis

Diagnosis is primarily clinical, based on characteristic retinal lesions. The presence of IgG or IgM antibodies in serum can be detected by ELISA (Enzyme-linked immunosorbent assay). Any positive testing, even undiluted, is significant. The presence of IgM in the infant serum is evidence of congenital infection because maternal IgM does not cross the placenta. Indications for treatment include a lesion threatening the macula or optic nerve head and severe vitritis. All immunocompromised patients should be treated.

### Treatment

Triple drug therapy is commonly used and consists of pyrimethamine (50 mg loading dose, then 25 mg orally twice daily), sulfadiazine (1g orally four times a day) and prednisolone (20–40 mg or more, started 1–2 days after the other drugs). Pyrimethamine can cause thrombocytopenia, leucopenia and folate deficiency. The drug is used only in combination with oral folinic acid (3–5 mg orally three times per week) to counteract the side effects. Weekly blood counts are required during therapy. Alternative drugs that can be used are co-trimoxazole (septrin), azithromycin and clindamycin. Atovaquone has been used mainly for immunocompromised patients (Figs 27.8 and 27.9).

### Rubella (German Measles)

Rubella is a relatively mild illness in the postnatal period, but results in a variety of abnormalities when acquired congenitally. Maternal infection acquired in the first trimester carries the greatest risk of complications. Systemic manifestations include congenital heart diseases, deafness, dental deformities, mental retardation, hydrocephalus, spina bifida, seizures and spasticity. Ocular abnormalities from rubella are microphthalmos, nuclear cataract, glaucoma, optic nerve abnormalities and retinopathy, which vary from salt and pepper retinal pigment epithelial disturbance to an

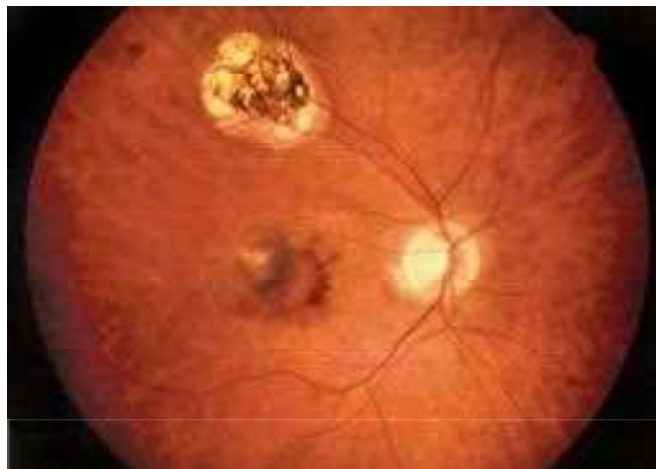


Fig. 27.9: Toxoplasma retinochoroiditis showing active and inactive lesions

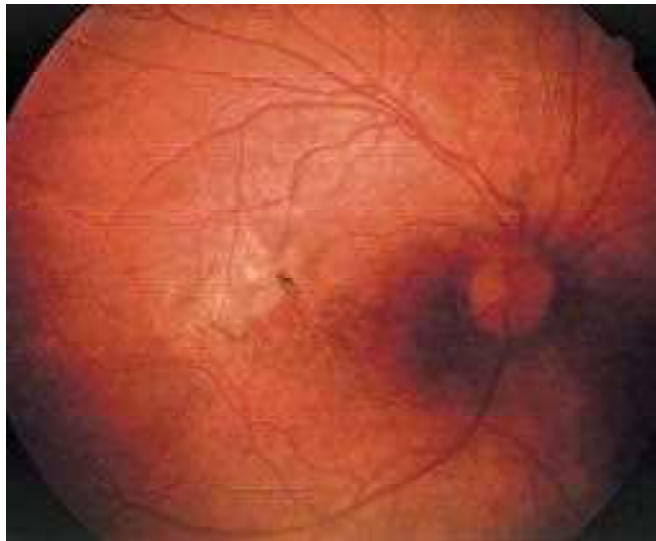


Fig. 27.10: Rubella "salt and pepper" retinopathy—may also be evident in the mid-peripheral retina

appearance of pseudoretinitis pigmentosa. The incidence of the disease has come down worldwide with the institution of routine vaccination (Fig. 27.10).

### Diagnosis

Diagnosis is based on a characteristic clinical picture, which may include any of the above features, and is supported by positive serum titres of antibody against the rubella virus. However, a negative antibody titre does not rule out rubella as antibodies may disappear with time.

### Treatment

Rubella cataract is managed by lensectomy. Intense post-operative inflammation may follow and requires adequate



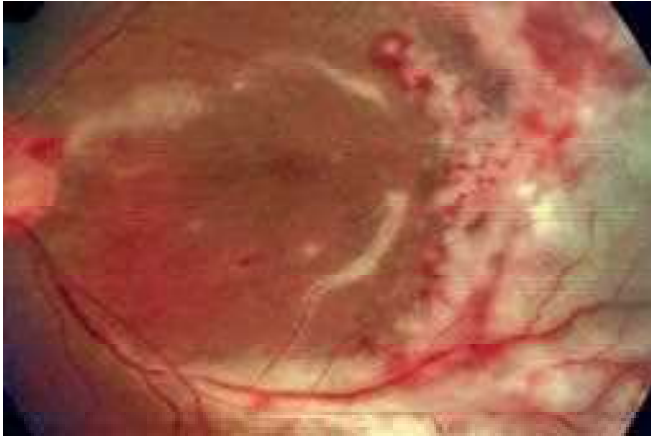


Fig. 27.11: Cytomegalovirus retinitis

## Cytomegalovirus

Cytomegalovirus belongs to the herpes family. Infections may occur transplacentally, during birth, through breastfeeding or from other infected children who continue asymptomatic secretion of the virus. Immunocompromised children may acquire the infection through blood transfusion, chemotherapy or organ transplantation.

Congenital CMV presents with jaundice, hepatosplenomegaly, thrombocytopenia and anaemia. Typically, there is microcephaly or hydrocephalus. Ocular manifestations include keratitis, uveitis, cataract, retinochoroiditis, optic nerve abnormalities and microphthalmos. The keratitis may manifest as punctate epithelial lesions, or as a dendritic, or geographical ulcer. Stromal keratitis presents as a zone of epithelial oedema with stromal thickening and keratic precipitates. Retinal involvement consists of bilateral progressive white areas of retinitis, exudates associated with haemorrhage, vasculitis, vitritis and necrosis (Fig. 27.11).

### Diagnosis

It is based on clinical presentation, confirmed with viral cultures and PCR (Polymerase chain reaction) based assays.

### Treatment

The treatment of epithelial keratitis is with topical acyclovir ointment 3%. Ganciclovir gel 0.15% and trifluorothymidine 1% drops are other effective agents. Stromal keratitis requires combined therapy with topical steroids, anti-viral agents. Disseminated disease and posterior segment involvement require intravenous antivirals such as acyclovir.

## Syphilis

Syphilis is a sexually transmitted infection caused by a Spirochaete, *Treponema pallidum*. Transplacental infection

Ocular manifestations are anterior uveitis, interstitial keratitis and pigmentary retinopathy. Malformed peg-shaped incisors, with nerve deafness and interstitial keratitis constitute Hutchinson's triad. Other signs include frontal bossing, a short maxilla, prognathism, a high arched palate, a saddle-shaped nose and linear scars around body orifices.

### Diagnosis

It is done by the venereal disease research laboratory test (VDRL), the fluorescent treponemal antibody absorption (FTA-ABS) test, or a micro-haemagglutination assay with *Treponema pallidum* antigen (MHA-TP).

### Treatment

The treatment of congenital syphilis in neonates younger than 1 month consists of aqueous crystalline penicillin G, 50,000 units/kg given intravenously every 12 hours for one week and then every 8 hours for a total of 10–14 days. Infants older than one month require aqueous crystalline penicillin G every 6 hrs for 10–14 days. Serological tests should be repeated and persistent positive titres at 6 months require re-treatment.

## Ophthalmia Neonatorum (Neonatal Conjunctivitis)

Ophthalmia neonatorum is a conjunctivitis that occurs within the first month of life. Chemical conjunctivitis due to treatment with silver nitrate used to be the commonest cause. However, prophylaxis with silver nitrate is now almost obsolete.

Neonatal conjunctivitis is caused by exposure to organisms in the birth canal. The common pathogens causing this condition are gonococcus, chlamydia and herpes simplex. Other infectious agents include *Streptococcus*, *Staphylococcus*, *Haemophilus* etc. Any discharge from a newborn infant's eye is pathological and should be taken seriously. Tear production is present from birth but does not become obvious until the infant is a few weeks of age.

## Gonococcal Conjunctivitis

Because of effective antenatal screening and prophylaxis, the incidence of gonococcal conjunctivitis has decreased markedly in affluent countries. In developing countries, however, gonococcal conjunctivitis continues to be a significant problem. Most serious gonococcal conjunctivitis is caused by *Neisseria gonorrhoeae* and presents within forty-eight hours of birth. There is marked lid oedema, mucopurulent discharge, severe chemosis and intense conjunctival congestion. Gonococcus has the power to invade

**Box 27.5:** Prophylaxis for ophthalmia neonatorum

Onset	Organism	Diagnosis	Treatment
2–4 days	<i>N.gonorrhoeae</i>	Gram negative diplococci	Ceftriaxone IM or IV Penicillin G IV Topical erythromycin Topical gentamicin
4–10 days	Chlamydia	Giemsa stains for basophilic inclusion bodies. Positive direct immunofluorescent assay.	Oral erythromycin Erythromycin eye ointment. Ciprofloxacin eye ointment.
4–7 days	Other bacteria (streptococci or staphylococci)	Gram positive cocci in pairs or chains	Neomycin – bacitracin ointment or Gentamicin eye drops
5–7 days	Herpes simplex	Viral culture, PCR Virus (HSV II)	Acyclovir 3% eye ointment Systemic acyclovir

effectively treated, ulceration can progress rapidly leading to perforation of the cornea, iris prolapse and lens extrusion. If the corneal ulceration heals with or without perforation, corneal scarring and opacification occur, causing reduced vision or loss of vision.

### Diagnosis

Gram staining of conjunctival scrapings reveals gram-negative intracellular diplococci.

### Treatment

Topical erythromycin ointment 2–4 hourly and intravenous or intramuscular ceftriaxone 30–50 mg/kg/day in divided doses are the treatment of choice. Gentamicin drops hourly and penicillin G injections 50,000 units/kg per day every 12 hours for 7 days are an effective alternative treatment. However, penicillin-resistant gonococci may be involved.

## Chlamydia Conjunctivitis

Chlamydiae are a relatively common cause of ophthalmia neonatorum. Onset is usually at age 4–10 days. Causative agents are *Chlamydia trachomatis* and *Chlamydia oculogenitalis* (called trachoma-inclusion conjunctivitis or TRIC). Lid oedema, chemosis and conjunctival congestion are less severe than in gonococcal conjunctivitis. Since infants do not have a subconjunctival adenoid layer, follicles do not appear. Pseudomembranes and superficial keratitis occur.

### Diagnosis

Conjunctival scrapings, stained with Giemsa's stain, show intracytoplasmic inclusion bodies. Enzyme-linked

immunoassays and direct immunofluorescent antibody tests are available.

### Treatment

The treatment of chlamydial conjunctivitis includes topical erythromycin ointment 3–4 times/day or ciprofloxacin drops 2–3 hourly along with oral erythromycin 30–50/kg per day in divided doses.

## Herpes Simplex

Most cases of neonatal herpetic conjunctivitis are due to Herpes simplex type II, but approximately one third are caused by Herpes simplex type I. The onset is usually between 1 and 2 weeks after birth. Presenting signs are a watery discharge and conjunctival injection. Fluorescein staining of the cornea shows punctate keratitis or dendritic ulceration.

### Diagnosis

Diagnosis is clinical, with conjunctival scrapings taken for viral culture and PCR in the absence of dendritic corneal ulceration.

### Treatment

Acyclovir 3% eye ointment is instilled 5 times a day. Systemic acyclovir is advised for recurrent viral keratitis and when there is systemic involvement.

Prophylaxis for ophthalmia neonatorum: Agents effective against both gonococci and TRIC, for example, erythromycin ointment, can be used prophylactically in the newborn (Box 27.5).

## ORBITAL CELLULITIS

The orbit is a pear-shaped cavity surrounded by bony walls, tapering posteriorly into the orbital apex and the optic canal, which contains the optic nerve. The cavity contains the globe, extraocular muscles, nerves, blood vessels, fibrous tissue and fat. The orbit is surrounded by the paranasal sinuses. The ethmoid air cells begin to develop in the second trimester and maxillary sinuses by 2 years of life. The frontal sinus develops between the fifteenth and seventeenth year. Infection from the sinuses spreads easily to the orbit through incomplete bony walls and the valveless veins of the orbit and sinuses.

Other sources of infection are facial skin, ear, teeth, direct inoculations after trauma and bacteraemic spread from a distant focus. Since the orbit is surrounded by bony walls, infection and inflammation cause increase in intra-orbital pressure leading to compromise of ocular and optic nerve function. Severe complications may result including cavernous sinus thromboses and intracranial abscess. Therefore, orbital cellulitis must be promptly recognised and aggressively treated.

### Classification

Orbital cellulitis can be classified into five stages as described by Chandler.

1. *Preseptal cellulitis*: Inflammation confined to the eyelids with mild anterior orbital involvement. Ocular motility and visual function are normal.
2. *Orbital cellulitis*: The four cardinal signs of orbital involvement are eyelid oedema, chemosis, proptosis and loss of motility. Visual impairment may occur.
3. *Sub-periosteal abscess*: Collection of pus within the sub-periosteal space causes local tenderness, fluctuation and non-axial proptosis.
4. *Orbital abscess*: Progression of cellulitis leads to intraconal and extraconal loculation of pus. Proptosis, inflammatory signs, ophthalmoplegia, visual deficit and systemic toxicity are increased at this stage.
5. *Cavernous sinus thrombosis*: Proptosis progresses rapidly and frequently becomes bilateral, and changes in mental state occur. Meningitis or intracranial abscess may follow. Inflammatory cells are present on lumbar puncture.

### Diagnosis

The commonest organism causing orbital cellulitis is *Staphylococcus aureus*, followed by *H. influenzae* and *M. catarrhalis*.

### Management

All children with orbital cellulitis (any stage) must be admitted to hospital and investigations performed to identify the source of infection. Material for culture and Gram's stained smear should be taken from the abscesses or nasopharynx. Signs of central nervous system involvement warrant lumbar puncture. Blood cultures are taken if leucocytosis and fever are present.

### Treatment

The antibiotic of choice for children with orbital cellulitis is parenteral cefuroxime, 100 mg/kg per day divided into three or four doses. The drug penetrates well into the soft tissues, bones and cerebrospinal fluid. Alternative regimens include Inj. Cloxacillin 100–150 mg/kg per day and gentamicin 3–5 mg/kg per day. If there is no response within 24 hours, the plan of management should quickly proceed to CT scan of the orbit and sinuses. If there is no direct site of inoculation seen, adequate drainage of a sinusitis abscess should be performed to prevent complications. The condition should be managed jointly by the ophthalmologist, paediatrician and neurologist, if necessary (Fig. 27.12).

## ALLERGIC CONJUNCTIVITIS

Allergic conjunctivitis is a type I hypersensitivity reaction caused by interaction between allergens and IgE antibodies on the surface of mast cells in the conjunctiva. This interaction causes degranulation of mast cells and release of mast cell mediators. The mediators that are implicated in allergic ocular disease include histamine, leukotrienes, eosinophilic chemotactic factors (ECF), eosinophilic granule major basic protein (EMBP), platelet-activating



Fig. 27.12: Left orbital cellulitis

factor (PAF), prostaglandin D<sub>2</sub> (PGD<sub>2</sub>) and several other less well-defined factors. The hallmark of allergic ocular disease is itching and hyperaemia. The chronic, recurrent and seasonal nature of the disease is characteristic. Affected children often have a history of asthma, allergic rhinitis and atopic dermatitis.

## Types

### *Seasonal Allergic Conjunctivitis (Hay Fever Conjunctivitis)*

Airborne allergens such as pollen, moulds, dander, grasses and weeds trigger a hypersensitivity reaction. As the name suggests the conjunctivitis is seasonal. Patients present with watering, conjunctival hyperaemia and chemosis.

### *Vernal Keratoconjunctivitis*

Vernal keratoconjunctivitis is a severe form of IgE-mediated mast cell dependent, type I hypersensitivity reaction. The onset of the disease is usually between 3 and 4 years of age. It can last 4–10 years with exacerbations and remissions. Symptoms include photophobia, severe itching, foreign body sensation and watering of the eyes. Vernal conjunctivitis is divided into two types, palpebral and bulbar. Both types can co-exist. The palpebral form has hypertrophied papillae, most prominently over the upper palpebral conjunctiva, the so-called cobblestone appearance (Figs 27.13 and 27.14). The conjunctiva has a milky hue and thick, ropy, white discharge. The bulbar form has nodules or gelatinous thickening of the conjunctiva along the limbus. Corneal involvement in vernal conjunctivitis includes punctate epithelial erosions, which can progress to form a sterile ulcer, called a shield ulcer, on the upper part of the cornea.



Fig. 27.13: Allergic conjunctivitis



Fig. 27.14: Giant papillae in vernal conjunctivitis

### *Atopic Keratoconjunctivitis*

Atopic keratoconjunctivitis is relatively rare in children, usually affecting young men with atopic dermatitis. Ocular symptoms and signs are similar to vernal keratoconjunctivitis. Unlike vernal keratoconjunctivitis, the inferior palpebral conjunctiva can be involved.

## Treatment

Treatment of all ocular allergic diseases is basically similar. It is often impossible to identify and remove the allergens. Therefore, therapy is directed towards relief of symptoms. Topical eye drops are the mainstay of therapy. The therapeutic agents employed are:

- Mast cell stabilisers: e.g.: Sodium cromoglicate, Lodoxamide and Nedocromil sodium.
- H<sub>1</sub>-receptor antagonists: e.g.: Emedastine difumarate.
- Agents with both mast cell stabiliser activity and H<sub>1</sub>-receptor blocking activity: e.g. Olopatadine hydrochloride and Ketotifen fumarate.

Other useful agents include non-steroidal, anti-inflammatory agents (NSAIDs) and topical steroids, although the risk of steroid-induced glaucoma and cataract limits the use of steroids to short intervals. Cyclosporin 2% may be useful in steroid-resistant cases, but is not widely available.

## LACRIMAL SYSTEM

### Anatomy

The lacrimal system consists of epithelium-lined passages that drain tears from each eye to the nasal cavity. Tears enter a punctum at the medial end of each eyelid, proceed through the upper- and lower-canalculi, which then form a common canaliculus on each side, and enter the lacrimal sac. This leads to the nasolacrimal duct, which opens into the inferior meatus of the nose beneath the inferior turbinate bone. The opening of the upper and lower canaliculi into

the common canaliculus is guarded by a one-way valve, the valve of Rosenmüller. The membranous opening into the nose is called the valve of Hasner.

### Congenital Abnormalities of the Lacrimal Drainage System

**Puncta:** The puncta may be absent (atresia), rudimentary, or covered by epithelium.

**Canaliculi:** The canaliculi may be rudimentary or anomalous in position and number.

**Amniocele (Dacryocystocele):** If there is obstruction at the valve of Rosenmüller and also inferiorly at the nasolacrimal duct, the lacrimal sac becomes distended. This condition may be present at birth or in early infancy and is termed an amniocele or dacryocystocele. The distended sac may become secondarily infected, causing dacryocystitis (Fig. 27.15).

#### Management

Hydrostatic massage and topical antibiotics may resolve the condition. If the condition persists lacrimal probing should be done no later than one month.

### Congenital Nasolacrimal Duct Obstruction

Nasolacrimal duct (NLD) obstruction may occur, most often due to delayed canalisation at the valve of Hasner. The clinician can elicit regurgitation of mucopurulent discharge with pressure over lacrimal sac area. The differential diagnosis of congenital NLD obstruction includes conditions which present with epiphora: punctal atresia, conjunctivitis, blepharitis, keratitis and congenital glaucoma.

#### Management

Conservative management includes lacrimal sac massage and administration of topical antibiotics. NLD obstruction

resolves spontaneously in the majority of the cases. Beyond one year of age, the rate of spontaneous resolution is significantly reduced.

#### Surgical Treatment

Early probing reduces the burden of conservative management and the potential for infection. However, delaying probing until one year age may avoid surgery altogether in many cases. The success rate of properly performed probing exceeds 90%. There is no convincing evidence that delaying probing until one to two years of age is harmful. However, after two years of age, simple probing may fail in as many as 30% of the cases.

**Balloon catheter dilation:** A lacrimal drainage system that appears to be blocked by scarring or constriction can be dilated by an inflatable balloon carried on a probe.

**Intubation:** Silicone tube intubation of the lacrimal system is usually recommended when one or more probings fail. The silicone tube should be left *in situ* for 3–6 months.

**Dacryo-cysto-rhinostomy:** Dacryo-cysto-rhinostomy (DCR) is indicated when repeated probings fail, when intubation cannot be accomplished and when significant symptoms recur after tube removal.

In this procedure, the sac wall is anastomosed to the nasal mucosa after creating a bony osteum, or defect, in the lacrimal fossa. The new passage thus opens from the lacrimal sac into the middle meatus of the nose (Fig. 27.16).

## CORNEA

### Embryology

The primitive cornea develops from surface ectoderm of the optic vesicle, and from neural crest cells, which migrate in waves over the surface of the primitive lens. The lens vesicle





separates from surface ectoderm by 6 weeks gestation, and by 4 months gestation, the corneal endothelial layer is complete. However, the iris insertion at this stage is anterior to the primitive trabecular meshwork (neural crest cells), and gradual posterior migration continues until the end of the first year of life.

Abnormalities of neural crest cell migration, proliferation or differentiation may occur, and present as a spectrum of anterior dysgenesis syndromes.

### Corneal Size and Shape in Childhood

In the neonate, the normal horizontal corneal diameter is 9.5–10.5 mm, which grows to reach 12 mm, the average adult corneal diameter, by the age of two years. Abnormalities of corneal size or shape may be evident at birth, and may show a characteristic inheritance pattern, or may occur sporadically. They may be associated with other abnormalities of the eye, and may be part of a syndrome affecting other systems of the body also (Box 27.6).

### Causes of Corneal Opacity in Childhood

Corneal disease remains the commonest cause of childhood blindness in the world today.

In the developing world, poor nutrition and the inadequacy of public health measures such as the provision of sanitation and immunisation remain key factors. In more affluent countries, congenital anomalies of the cornea form a small but significant proportion of the blinding conditions in childhood.

The normal cornea is avascular and transparent, and the cause of any opacity, which may interfere with vision, must be diagnosed, and if possible, treated, at the earliest possible opportunity, to avoid irreversible damage and visual loss, or the development of amblyopia.

### Xerophthalmia and Nutritional Corneal Ulceration or Keratomalacia

Xerophthalmia describes a dry ocular surface due to vitamin A deficiency, which may progress to keratomalacia, an acute keratitis due to untreated vitamin A deficiency, which in turn,

if not treated urgently and adequately, progresses rapidly to corneal melting and perforation.

The earliest symptom of vitamin A deficiency is night blindness. This should be specifically asked about in consultations or in paediatric eye screening programmes, in developing countries. If vitamin A remains deficient, the conjunctiva becomes dry, with a wrinkled, reddened or pigmented appearance. Bitot's spots may form on the exposed conjunctiva, lateral, and sometimes medial, to the cornea. They appear like a triangular or irregular area of froth or tiny bubbles on the conjunctiva, sometimes with underlying pigmentation. Adequate treatment with vitamin A at this stage, and ensuring that inadequate dietary intake as well as conditions causing diarrhoea and vomiting are properly managed, can prevent the occurrence of keratomalacia and blindness. Conversely, neglect of early signs of vitamin A deficiency results in a high risk of adherent leukoma formation. A dense corneal scar develops, due to corneal perforation with adherence to the iris and lens, causing cataract. Secondary infection may result in endophthalmitis. The latter may be life-threatening, as is continuing, untreated vitamin A deficiency (Figs 27.17 and 27.18).

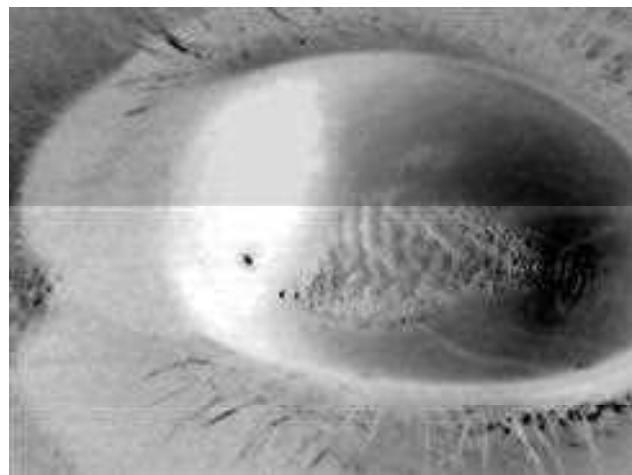


Fig. 27.17: Bitot's spots in vitamin A deficiency

#### Box 27.6: Corneal size and shape in childhood

	<i>Megalocornea</i>	<i>Keratoglobus</i>	<i>Keratoconus</i>	<i>Microcornea</i>
Typical Features	Horizontal corneal diameter > 12 mm in neonate, or 13 mm in an older child. Usually bilateral.	Thinned, globular shaped cornea, with deep anterior chamber. Episodes of corneal oedema. Risk of corneal rupture with minor trauma.	Coning of the central or paracentral cornea due to progressive thinning. Often presents in adolescence, with gradual or rapid progression.	Horizontal corneal diameter < 9 mm in the neonate, or 10 mm in an older child. In nanophthalmos, other ocular structures as the cornea, are smaller than normal
Inheritance Pattern	X-linked recessive	Autosomal recessive	Undetermined	Sporadic, or autosomal dominant
Associations	Glaucoma, lens subluxation, iris hypoplasia and ectopic pupil	Ehlers-Danlos type IV syndrome	Down syndrome, other types of mental retardation. Atopy.	Cataract, coloboma, high myopia, persistent hyperplastic primary vitreous, acute angle



**Fig. 27.18:** Keratomalacia with corneal melt, due to vitamin A deficiency

## World Health Organisation (WHO) Classification of Xerophthalmia

XN	Night blindness
X1A	Conjunctival xerosis
X1B	Bitot's spots
X2	Corneal xerosis
X3A	Corneal ulcer < one third of corneal surface
X3B	Corneal ulcer > one third of corneal surface
XS	Corneal scar
XF	Xerophthalmic fundus

If the deficiency is progressive, children may go through this spectrum of clinical signs. When there is a sudden increase in metabolic demand, as in the case of infections such as measles or diarrhoea, vitamin A deficiency may rapidly progress to keratomalacia without passing through the whole spectrum of clinical signs. Severe keratomalacia is usually seen in children below 5 years of age. Children between 6 months and 3 years are particularly at risk.

**Prevention:** 2,00,000 IU of vitamin A should be administered orally every 6 months to children from 1 to 6 years of age. The first dose can be given at the time of MMR vaccination. Measles vaccination has played an important role in the prevention of vitamin A related blindness. Vitamin A is teratogenic; therefore, administration is not advised in early pregnancy. It can be administered to women at delivery or within one month of delivery, and breast-feeding should be encouraged. Health education and improved nutrition, particularly with foods rich in vitamin A, contribute significantly to prevention of deficiency.

**Keratomalacia:** Keratomalacia is a medical emergency. The affected child requires hospitalization for adequate treatment. Treatment schedule for vitamin A deficiency in keratomalacia:

Timing	< 1 year of age	> 1 year of age
On diagnosis	100,000 IU	200,000 IU
Following day	100,000 IU	200,000 IU
2–4 weeks later	100,000 IU	200,000 IU

In addition secondary bacterial infection should be treated with combination antibiotic therapy (for example, gentamicin drops + cefazolin drops), and protein-calorie malnutrition and diarrhoea should be treated. Small punched out corneal ulcers which occur, usually heal well, but residual scarring may persist.

## Other Disorders Affecting the Cornea

### *Infection of the Cornea*

- Ophthalmia neonatorum refers to neonatal conjunctivitis. If untreated, corneal infection and scarring may be a complication.
- In older children, minor corneal trauma or untreated conjunctivitis, particularly in the presence of malnutrition or other systemic illness, may cause corneal infection and ulceration, with subsequent corneal opacity.
- Measles keratitis remains a significant cause of corneal scarring and blindness in some regions, although measles immunisation and improved childhood nutrition have markedly reduced the incidence of measles and its complications.
- Trachoma, primarily an infection of the conjunctiva, can result in scarring of the tarsal conjunctiva, with consequent misdirected eyelashes or trichiasis, which constantly rub against the cornea. This causes chronic irritation, sometimes with corneal ulceration and scarring.
- Herpes simplex keratitis is more commonly seen in young adults, but can occur in childhood, particularly in atopic individuals.

Injury due to birth trauma, which usually involves Descemet's membrane (the protective layer of the cornea, adjacent to the endothelium), may resolve spontaneously, or with simple measures to avoid infection if the epithelium is damaged, but may require subsequent correction of astigmatism and patching of the other eye, to overcome amblyopia.

### *Injury due to Accidental Trauma*

Injury due to accidental trauma may also cause corneal scarring in childhood. Delayed treatment is likely to be associated with secondary infection and a worsening of prognosis. Agricultural injuries with secondary fungal infection and injuries (often gram negative or anaerobic infections) from pet animals may be particularly severe. In penetrating injuries, adequate tetanus immunisation should always be ensured.



**Fig. 27.19:** Enlarged, hazy cornea due to congenital glaucoma

### *Chemical Injuries*

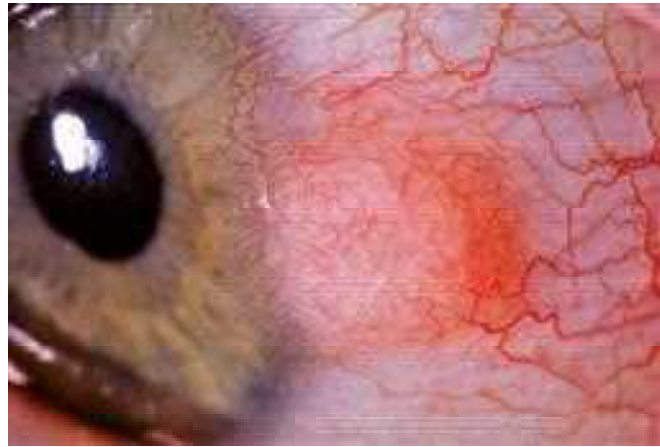
Chemical injuries constitute an emergency where time is of essence. Immediate, copious irrigation of the injured eye, including the upper conjunctival fornix (the area under the upper eyelid) with buffered saline or Ringer's lactate where possible, but with clean water if that is all that is available, can save an eye and its sight, which may otherwise be lost. Acids cause coagulation of surface proteins on the cornea with rapid scarring, whereas alkalis penetrate rapidly into the eye causing widespread destruction of intraocular tissues as well as of the ocular surface. Prompt and prolonged irrigation of the eye dilutes and removes such chemicals from the ocular surface, thereby preventing or minimising these types of destruction.

### *Congenital Glaucoma*

Congenital glaucoma can present with cloudy or opaque corneas, which are usually also enlarged. The raised intraocular pressure initially causes enlargement of the globe, which, in infants, is relatively elastic. Without treatment, however, the disease progresses causing atrophy of the optic nerve, and irreversible visual loss. This condition must always be considered, therefore, in the presence of hazy or opaque corneas, in order that early treatment can be instituted, and blindness prevented (Fig. 27.19).

### *Dermoids on the Cornea*

Dermoids on the cornea, usually extending from across the rim, or limbus of the cornea (most commonly inferotemporally), consist of hamartomatous fibrofatty tissue and keratinised epithelium. They sometimes contain skin appendages such as hair follicles, sebaceous glands and sweat glands, and may be up to a centimetre in diameter. They may involve the corneal stroma, but not usually the whole thickness of the cornea.



**Fig. 27.20:** Limbal lipodermoid

vision. Smaller ones may result in astigmatism (as may surgical excision), which, uncorrected can cause amblyopia (Fig. 27.20).

### *Anterior Segment Dysgenesis*

Anterior segment dysgenesis includes a spectrum of developmental genetic anomalies of peripheral and central anterior segment structures, the more severe of which include corneal scarring. The peripheral developmental anomalies include posterior embryotoxon, and Axenfeld-Rieger syndrome. The central developmental anomalies include posterior corneal depression and Peter's anomaly. In Peter's anomaly, there is a posterior corneal defect with a central stromal opacity, with iris strands often adherent to its posterior surface. The opacity may lessen with time.

### *Sclerocornea*

Sclerocornea is a congenital condition in which, as its name suggests, the cornea is opaque and appears undifferentiated from the sclera. Flattening of the cornea may also occur. The condition is often associated with other ocular or systemic abnormalities.

### *Mucopolysaccharidosis*

Mucopolysaccharidoses and mucopolidoses constitute a varied group of conditions with lysosomal disorders, resulting in a range of mucopolysaccharides or mucolipids not being broken down and therefore accumulating in the tissues. Some of these conditions manifest ocular abnormalities. In Hurler's syndrome (mucopolysaccharidosis IH) and in Scheie's syndrome (mucopolysaccharidosis IS), corneal clouding occurs within the first 6 months to 2 years of life. In mucopolidosis IV, corneal clouding may occur in the first few weeks of life. In these conditions, electron microscopy on conjunctival biopsies

## Congenital Hereditary Endothelial Dystrophy

Congenital Hereditary Endothelial Dystrophy (CHED) manifests in the early days of life. It is a defect of the endothelial layer of the cornea and of the adjacent Descemet's layer, resulting in diffuse oedema of the epithelial and stromal layers of the cornea. The cornea is, therefore, thickened and hazy, and must be differentiated from congenital glaucoma, where the corneal diameter is usually increased and the intraocular pressure is elevated. CHED is a rare inherited condition, which may be autosomal dominant or autosomal recessive.

## Treatment of Corneal Opacities in Childhood

Treatment of corneal injuries, infections and damage due to vitamin A deficiency must be prompt and adequate in order to preserve, or restore sight. In many situations, there may be astigmatism or corneal scarring despite repair, resolution of infection, or restoration of adequate levels of vitamin A in the body. Refractive correction of astigmatism can then be undertaken, or corneal grafting if appropriate.

Corneal grafting requires special care and expertise in children, and the final visual outcome maybe poorer than one would hope. Furthermore, since deprivation amblyopia has been found to be best reversed by treatment of the underlying cause within the first 3 months of life, the surgery, and the anaesthesia required, may be more complex than if performed later. Some studies have shown less corneal rejection and a better final visual outcome if surgery is delayed until approximately one year after birth.

Where treatment of corneal opacities is not possible, support of the child and the family is essential, with appropriate advice and information given, and all possible rehabilitation measures put in place to enable the child to live as full a life as possible, and to avoid the additional risks and possible harm associated with poor sight.

## SYSTEMIC DISEASES WITH CORNEAL MANIFESTATIONS IN CHILDHOOD

### Congenital Syphilis

Interstitial keratitis secondary to congenital syphilis may present during the first 10 years of life, with corneal oedema and aggressive vascularisation of the deep stromal layer of the cornea, giving it a pink appearance ('salmon patch'). Blood flow through these vessels gradually stops over a period of weeks to months, leaving greyish white 'ghost' vessels visible deep in the stroma, which are evident throughout life.

### Leprosy

Although the prevalence of leprosy has diminished dramatically over the past 15 years, new cases continue to

be diagnosed in children, and may result in impairments such as lagophthalmos and impaired corneal sensation. Neurotrophic keratitis, and exposure keratitis may both result in corneal opacity, and secondary infective keratitis can cause more severe corneal damage or corneal perforation and endophthalmitis. Corneal lepromas (granulomatous lesions which develop as a response to the presence of *Mycobacterium leprae*) are now rare, but chronic iritis may result in band keratopathy—a condition that occurs in eyes with chronic inflammation, in which calcific material is deposited in a band-shaped area across the cornea.

### Mucopolysaccharidoses

All of the mucopolysaccharidoses cause varying degrees of corneal haziness due to deposits in the cornea, except for Hunter's syndrome (mucopolysaccharidosis II) (see previous section).

### Hepatolenticular Degeneration (Wilson's Disease)

Wilson's disease is an inborn error of metabolism in which excess copper deposition occurs in the liver, kidney, and basal ganglia of the brain. Inheritance is autosomal recessive, and clinical features include cirrhosis of the liver, renal tubular damage, and a type of parkinsonism. A copper coloured ring (the Kayser-Fleischer ring) in Descemet's layer of the cornea is a diagnostic feature of established disease, but may not be present in the early stages. Copper deposits are first seen in the 12 and 6 o'clock positions, and then form a complete ring.

### Cystinosis

Cystinosis is a rare, metabolic disease in which intracellular cystine levels are elevated, resulting in the deposition of cystine crystals in various parts of the body. In infants, failure to thrive, rickets and progressive renal failure occur, and are known as Fanconi's syndrome. Ocular features develop in the first year of life, and include the deposition of crystals in the peripheral cornea and throughout Descemet's layer, as well as on the anterior iris surface and in the conjunctiva. Photophobia occurs. Oral cysteamine reduces systemic crystal deposition and is more effective than topical cysteamine, which is also difficult to obtain (Fig. 27.21).

### Familial Dysautonomia (Riley-Day Syndrome)

This is an autosomal recessive condition seen largely in Ashkenazi Jews. There is autonomic dysfunction with relative insensitivity to pain and temperature instability.

Abnormal lacrimation and decreased corneal sensation



**Fig. 27.21:** Deposition of cystine crystals in the cornea in cystinosis

with secondary opacity. Topical artificial tear preparations and tarsorrhaphies may protect the corneas to some extent.

## CHILDHOOD LENS DISORDERS

Childhood lens abnormalities include cataract, subluxation, and abnormal lens shape and development. These abnormalities continue to be an important cause of visual impairment. Lens disorders can be the presenting sign of systemic abnormalities involving the central nervous system, the urinary tract and the skin.

### Paediatric Cataracts

The cause of most cataracts is unknown. They are most commonly inherited in an autosomal dominant pattern, but x-linked and autosomal recessive types have been reported. Trisomy 13, 18 and 21 are associated with cataracts. The onset, location and morphology of cataracts provide important information regarding their cause and likely visual outcome following surgery. Cataracts that present at birth are most serious, because the visual system is still immature. Amblyopia is inevitable unless the visual axis is rendered clear by 6–8 weeks of age. Unilateral cataracts tend to cause denser amblyopia because of the rivalry between the two eyes.

### Morphological Classification of Cataracts

Cataracts can be classified as:

- Anterior (Anterior polar cataract, anterior sub-capsular and anterior lenticonus)
- Lamellar
- Nuclear
- Posterior (Posterior lenticonus, Persistent hyper-plastic primary vitreous, posterior subcapsular cataract)



**Fig. 27.22:** Lamellar cataract

### Anterior Cataract

Anterior polar cataract is a small white discrete opacity at the centre of the anterior capsule. These opacities are usually non-progressive and visually insignificant. One-third of them are bilateral. Most of them can be managed conservatively. However, because they can be associated with strabismus, anisometropia and amblyopia, follow up is necessary.

Anterior pyramidal cataract is a white conical opacity at the anterior pole. These cataracts are usually bilateral and are not associated with any systemic disease.

Anterior subcapsular cataract lies immediately under the anterior capsule of the lens in the anterior cortex. Such cataracts are usually idiopathic. However, the possibility of trauma or Alport's syndrome should be considered. Lens changes in Alport's syndrome consist of bilateral anterior subcapsular cataract and bilateral anterior lenticonus.

### Lamellar Cataract

Lamellar cataracts occupy specific zones in the lens cortex and have spoke-like radial opacities. Most lamellar cataracts progress and require surgery. These may be unilateral or bilateral. Bilateral lamellar cataracts are frequently inherited in an autosomal dominant manner. Metabolic diseases such as neonatal hypoglycemia and galactosaemia can cause bilateral lamellar cataracts (Fig. 27.22).

### Nuclear Cataract

Nuclear cataract is an opacity located within the embryonic or foetal nucleus. These cataracts can be unilateral or bilateral. Bilateral nuclear cataracts are often inherited according to an autosomal dominant pattern. Intrauterine rubella infection causes a distinctive nuclear cataract with a 'shaggy' appearance. Visual prognosis in these cataracts is only fair, even after early surgery.

### Posterior Cataract

Posterior lenticonus is almost always unilateral and can cause myopia and astigmatism. Therefore, it is important to monitor vision and prescribe appropriate optical correction to prevent amblyopia.

Persistent hyperplastic primary vitreous (PHPV) is caused by failure of regression of the primitive hyaloid vascular system. PHPV occurs sporadically, is almost always unilateral and is associated with microphthalmia. Clinically there is a retrolenticular fibrovascular membrane, which extends to the optic disc as a stalk. The membrane may contract, push the lens-iris diaphragm anteriorly and cause glaucoma.

Posterior subcapsular cataracts in children are often stellate, or rosette-shaped, and secondary to trauma or steroid-induced. They affect vision significantly and require surgery, for which the visual prognosis is excellent (Figs 27.23 and 27.24).

### Evaluation of Cataract

Examination in a darkened room is performed by shining the light of a direct ophthalmoscope into both eyes simultaneously, in order to detect normal, symmetrical red reflexes. This test is called Bruckner's test. Any central opacity or surrounding cortical distortion more than 3 mm is considered to have a significant effect on vision. Taking a family history is important in order to elicit whether there is an autosomal dominant or X-linked pattern of inherited cataract. General physical examination in addition to examination of the anterior and posterior segments of the eye is required. Unilateral cataracts are generally not metabolic or genetic in origin, and therefore laboratory tests are not helpful, except a TORCHES titre (see intrauterine infectious disease). Laboratory tests, however, can provide valuable information in bilateral cataracts, particularly is Lowe's syndrome and galactosaemia. Recommended tests include a urine test for reducing substances after milk feeding, TORCH titre and VDRL test. Other optional tests include a urine test for amino acids, and blood tests for calcium, phosphorus and red-cell galactokinase level.

### Surgery

The principal surgical options are removal of lens matter through an anterior capsulorhexis (i.e. a hole made in the anterior capsule), or lensectomy with a posterior approach. Intraocular lens implantation (IOL) at the same time in infants remains controversial. Intraocular lens implantation is recommended in children above age 2 years. Because rapid posterior capsule opacification occurs, a controlled moderate posterior capsulotomy and anterior vitrectomy should be performed at the time of surgery. This allows establishment of a clear visual axis, facilitating accurate retinoscopy and

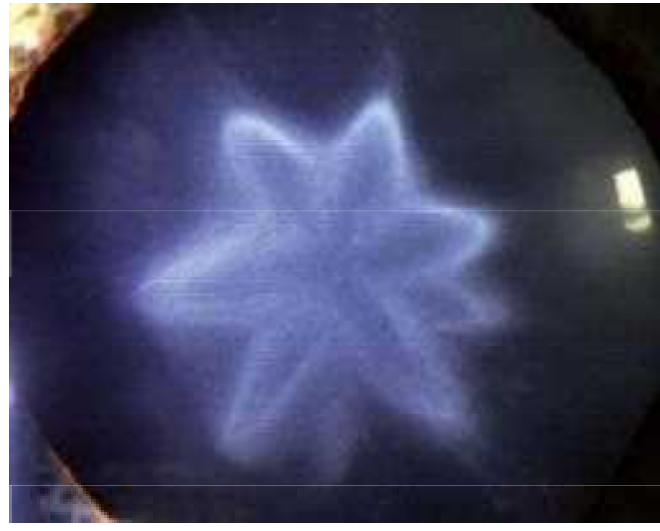


Fig. 27.23: Stellate cataract

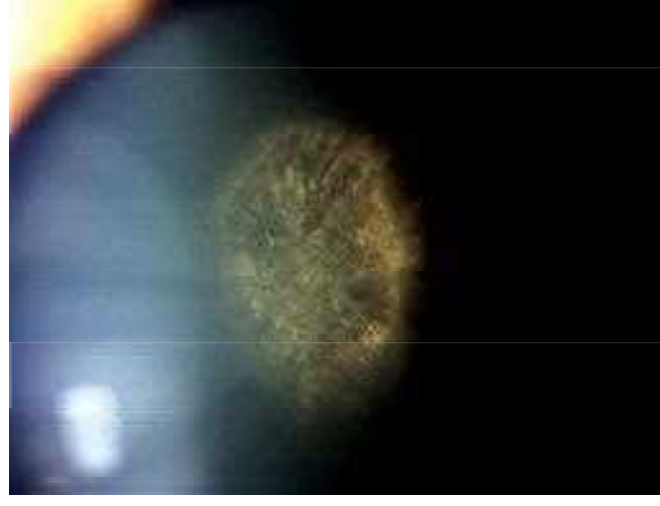


Fig. 27.24: Steroid-induced cataract

Optical rehabilitation is important to avoid amblyopia. If an IOL is not inserted at surgery, aphakic spectacles or contact lenses are required. Aphakic spectacles are the safest and can be easily changed according to the refractive requirement. Contact lenses provide more constant refractive correction but are less easily changed, may be displaced by eye rubbing, and can pose a risk of infection and corneal ulcer. If an intraocular lens is inserted, it is important to ensure that it is placed within the lens capsule ('in the bag'). Children often require spectacle correction, especially for reading in spite of the intraocular lens. All children need long-term follow-up for changes in refractive status, amblyopia management, intraocular pressure monitoring and posterior segment evaluation.

A good visual outcome depends on the timing of surgery,

amblyopia. In general, children with bilateral cataracts achieve a better final visual outcome than those with a unilateral cataract.

### Dislocation of the Lens

When the lens is not in the normal position, it is said to be subluxated or dislocated (if completely dislodged). The signs of lens subluxation are iridodonesis (a shimmering movement of the iris due to lens movement posterior to it), phakodonesis (a shimmering movement of the lens) and visibility of the lens edge within the pupil. Important systemic conditions associated with subluxated lenses are:

- Marfan's syndrome
- Homocystinuria
- Weill-Marchesani syndrome
- Hyperlysaemia
- Sulphite oxidase deficiency
- Ehlers-Danlos syndrome.

Subluxated lenses may remain stable, and satisfactory vision can be achieved with an appropriate astigmatic, or hypermetropic (aphakic) spectacle correction. In other situations, where the subluxation is unstable or progressive, lens extraction may be indicated to avoid complications such as dislocation into the anterior chamber and secondary glaucoma (Figs 27.25 to 27.27).

## PAEDIATRIC GLAUCOMA

Childhood glaucomas may be classified into two groups:

1. Primary congenital glaucoma
2. Secondary congenital glaucoma

### Primary Congenital Glaucoma

This condition is bilateral in almost two-thirds of patients, occurs more frequently in males and has no racial predilection. Inheritance is mostly sporadic or autosomal recessive with variable penetrance.

The cause of this type of glaucoma is abnormal development of the anterior chamber angle which causes obstruction to outflow of the aqueous. This in turn causes increased intraocular pressure and the relatively elastic sclera of the infant eye responds with stretching and enlargement of the globe.

### Clinical Features

The classic triad of symptoms comprises:

- Epiphora
- Photophobia
- Blepharospasm.

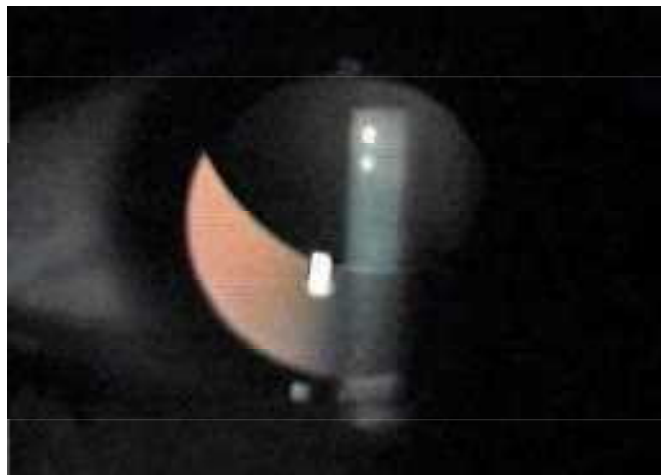


Fig. 27.25: Marfan's syndrome: Lens subluxed upwards

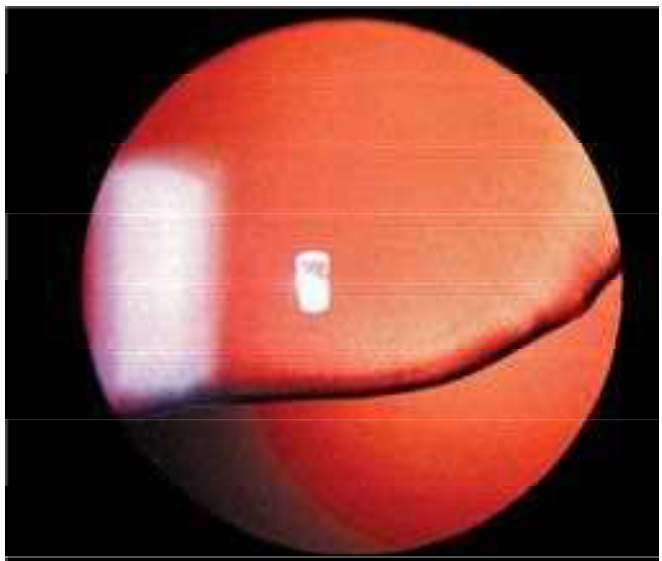
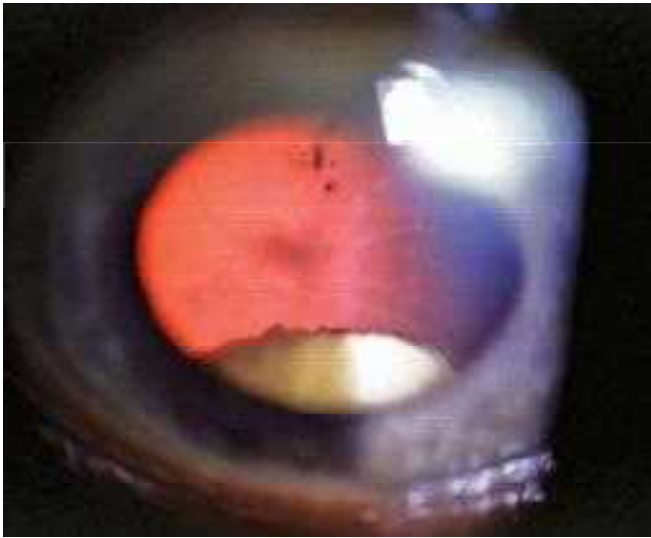


Fig. 27.26: Marfan's syndrome: Upward subluxation of lens seen against red reflex

### Signs

- A hazy cornea. Corneal oedema is the presenting sign in most infants, often accompanied by breaks in Descemet's membrane called Haabs striae.
- Increased corneal diameter. The normal horizontal corneal diameter is 9.5–10.5 mm at birth and 10.5–11.5 mm at one year. A diameter of more than 12.5 mm is suggestive of glaucoma.
- Deep anterior chamber
- Increased intraocular pressure
- Optic disc changes (pallor, atrophy).



**Fig. 27.27:** Homocystinuria: Lens subluxed downwards

## Diagnosis

A detailed ocular examination under anaesthesia should be done. The following tests are required.

- Measurement of corneal diameter
- Intraocular pressure recording
- Gonioscopy
- Ophthalmoscopy.

## Differential Diagnosis

- Megalo-cornea
- Nasolacrimal duct obstruction
- Keratitis
- Trauma
- Metabolic disorders.

## Secondary Congenital Glaucoma

Ophthalmologist and paediatrician must be aware of associated systemic and ocular anomalies in an infant with glaucoma. Example of associated systemic abnormalities includes:

- Sturge-Weber syndrome
- Neurofibromatosis
- Oculocerebrorenal syndrome (Lowe's syndrome)
- Congenital rubella.

## Treatment

### Medical Therapeutic Agents

- Carbonic anhydrase inhibitors
- Topical beta-blockers
- Prostaglandin derivatives

## Surgical Therapy

- Goniotomy
- Trabeculotomy
- Trabeculectomy
- Glaucoma implants
- Cycloablation.

All cases of childhood glaucoma require careful, long-term follow-up. Visual loss is not only due to corneal scarring and optic nerve damage, but may also be due to significant astigmatism and amblyopia. Glaucoma that presents at birth has a poor visual prognosis. Presentation at 3–12 months age is associated with a better visual prognosis.

## UVEITIS IN CHILDREN

### Introduction

Uveitis is an inflammatory response to a physical or biological insult, involving part of, or the whole uveal tract. Polymorphonuclear leucocytes and monocytes accumulate in the uvea and stimulate the release of chemical mediators. These may remove the offending stimulant as well as creating further inflammation. Approximately 50% of children presenting with anterior uveitis manifest no obvious cause of the condition. The commonest identifiable cause, however, of anterior uveitis in the paediatric age group, is juvenile rheumatoid arthritis, particularly the pauciarticular type.

Uveitis in children accounts for 2–8% of uveitis occurring at all ages. It presents particular challenges to the clinician:

- Late presentation is common, because children may not be able to express their symptoms
- Potential side effects and poor compliance may limit the effectiveness of treatment
- Steroid-induced glaucoma, secondary cataract and band keratopathy have a higher incidence rate in children than in adults.

### Causes of Uveitis in Children

The majority of uveitis cases in children are bilateral, non-granulomatous and anterior. Intermediate and pan-uveitis are seen less commonly, and posterior uveitis, least of all.

Causes of each type of uveitis are listed in Box 27.7.

### Clinical Features

The symptoms of acute anterior uveitis include pain, redness of the eye and photophobia. There may be watering of the eye. In chronic uveitis, which may be anterior, intermediate or posterior. There is often little in the way of pain or redness, but vision may be blurred, or there may be an awareness of 'floaters' in the eye. On examination, in acute anterior uveitis, the following findings are typical: conjunctival



**Box 27.7:** Causes of uveitis*Anterior uveitis*

Juvenile rheumatoid arthritis

Trauma

Sarcoidosis

HLA B27-related

Herpetic disease

Sympathetic ophthalmia

Syphilis

Lyme disease

Fuchs' heterochromic  
cyclitis

Viral syndromes

Idiopathic

*Intermediate uveitis*

Pars planitis

Sarcoidosis

Tuberculosis

Toxocariasis

Lyme disease

Idiopathic

*Posterior uveitis*

Toxoplasmosis

Ocular histoplasmosis

Herpetic disease  
Cytomegalovirus  
(in the immunosuppressed)

Syphilis

Sympathetic ophthalmia

Lyme disease

Idiopathic

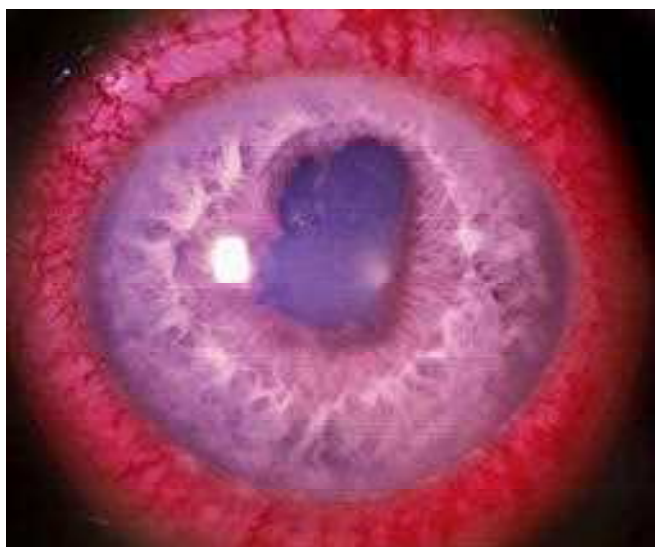
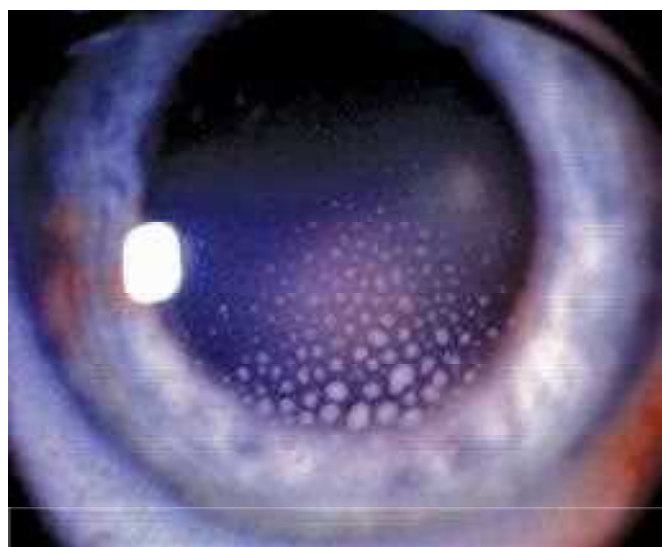
*Panuveitis*

Sarcoidosis

Vogt-Koyanagi-Harada  
syndrome

Behcet's syndrome

Idiopathic

**Fig. 27.28:** Acute anterior uveitis with posterior synechiae**Fig. 27.29:** Mutton fat keratic precipitates

the limbus of the cornea. Keratic precipitates (KP), which may be large and clumped together ('mutton fat' KP), or fine and diffuse, are usually present on the corneal endothelium, and cells (inflammatory cells), and flare (protein exudate) are seen on slit lamp examination of the aqueous fluid, and/or the vitreous (when the posterior segment of the eye is involved). In acute anterior uveitis, the pupil may be miosed (constricted), or irregular, due to adhesions of the iris to the anterior lens surface, known as posterior synechiae (Anterior

synechiae refer to adhesions of the peripheral iris to the corneal endothelial surface, which may occur in conditions with severe inflammation or in prolonged shallowing of the anterior chamber).

In intermediate uveitis, creamy, inflammatory exudates are evident in the pars plana of the ciliary body, at the anterior periphery of the retina, and in posterior uveitis, similar lesions may be present elsewhere on the retina, or in the vitreous (Figs 27.28 and 27.29).

## Management

### *Anterior Uveitis*

Investigation for an underlying cause of anterior uveitis in children is usually undertaken when the uveitis is bilateral, or recurrent, or does not respond to initial therapy.

Topical steroid and mydriatic drops are usually effective, and the minimum effective doses are used to prevent posterior synechiae and reduce the number of cells in the anterior chamber, while minimising side effects: such as visual blurring in the case of mydriatics, and secondary cataract or glaucoma in the case of steroids.

Periocular depot injections of steroid, oral steroids and systemic immunosuppressives are all reserved for patients in whom topical therapy yields an inadequate response, and they should be used with care due to the occurrence of significant side effects in children.

Surgery for secondary cataracts may be necessary, and corneal epithelial debridement is combined with chelation therapy, for removal of band keratopathy.

Children who present with juvenile rheumatoid arthritis should have regular eye screening, as the associated uveitis is often symptom free in its early stages.

Blunt trauma to the eye may present as a mild self-limiting anterior uveitis. More severe blunt trauma, or trauma involving damage to the eye by a sharp object, presents with more severe disruption to the globe, including lens dislocation, retinal detachment or perforation of the globe. In these situations, surgical intervention is required. In penetrating injuries, both infectious and sympathetic endophthalmitis are major risks, particularly if treatment is delayed. Tetanus prophylaxis must also be ensured in all such cases.

### *Intermediate Uveitis (Pars Planitis)*

Due to its chronic nature, treatment is initiated in situations of moderate reduction in visual acuity. Topical or periocular steroids should be tried first, and systemic steroids used only if these do not prove effective. Systemic immunosuppressive therapy is considered if therapy is prolonged to avert steroid-induced cataract and systemic side effects. Other measures including vitrectomy may be indicated in severe, refractory intermediate uveitis.

### *Posterior Uveitis*

Inflammation of the posterior segment occurs in over 50% of childhood uveitis cases. Approximately one third of these are idiopathic, and on exclusion of conditions requiring more specific measures, treatment is administered as for intermediate uveitis. Almost half the cases of posterior

standard treatment for this has hitherto been a combination of sulphadiazine and pyrimethamine, although more recently, azithromycin has also proved to be effective. Additional systemic steroids are sometimes required.

### *Systemic Infections and Uveitis*

Systemic infections, which may include, or may initially present with uveitis include candidiasis, tuberculosis, syphilis and leprosy.

Systemic candidiasis occurs in drug addicts and in individuals with immunosuppression due to diseases such as cancer or other diseases associated with immunosuppression, or to immunosuppressive therapy. When the eye is involved, typical findings include cells, fibrinous strands and 'puff balls' in the vitreous; discrete, and sometimes confluent haemorrhages and creamy exudative lesions on the retina. Diagnosis is confirmed by vitreous biopsy, and intravitreal and intravenous antifungal agents are required.

Tuberculosis may affect any part of the uvea, and may manifest as a localised mass with surrounding inflammatory reaction, and mutton fat keratic precipitates on the corneal endothelium. In miliary tuberculosis, discrete miliary choroidal tubercles or peripheral exudative 'candle wax drippings' may be visible on fundoscopy. Focal retinopathy resembling toxoplasmic retinochoroidopathy may also be seen. Anti-tuberculous treatment is mandatory and topical steroids should be used with care, only if systemic antituberculous treatment is also given.

Syphilis may cause localised or diffuse uveitis or choroiditis, which resolve leaving areas of iris or choroidal atrophy.

Multibacillary leprosy often causes an acute anterior iritis, particularly as part of a Type II, or erythema nodosum leprosum (ENL) reaction. Chronic, low-grade uveitis is also seen in multibacillary leprosy, and as in juvenile rheumatoid arthritis, may present with secondary features such as cataract, iris atrophy, ocular hypotony or band keratopathy. Thus, regular ocular screening of such patients is recommended. Along with anti-leprosy multi-drug therapy, topical steroids and cycloplegics are indicated. Where the corneal epithelial surface is compromised due to impaired corneal sensation or weakness of orbicularis oculi, topical steroids must be used with care, and topical non-steroidal anti-inflammatory agents may be preferable.

Systemic viral illnesses including chicken-pox and cytomegalovirus infection are occasionally associated with a posterior uveitis and retinochoroiditis. Inflammatory cells in the vitreous are seen, with foci of exudate and haemorrhage on the retina and sheathing of peripheral retinal vessels.

Onchocerciasis is a parasitic disease caused by onchocerca

this disease includes West Africa, central Africa and Yemen, as well as parts of Central America.

The life cycle of the worm includes humans in whom the microfilaria mature into adult worms, and a second vector, the *Simulium* fly; in which young microfilaria develop into mature ones. The larval microfilaria are found all over the body, and accumulate in the eye in large numbers. Microfilaria may be seen under the conjunctiva, or in the anterior chamber on slit-lamp examination. Symptoms occur largely as a result of an inflammatory response to dead or dying microfilaria. A sclerosing keratitis, typically starts peripherally, and spreads to include the whole cornea. Uveitis occurs, with pigmented keratic precipitates and posterior synechiae. Optic atrophy and chorioretinal atrophy are often observed, and glaucoma may occur in the absence of obvious infection, possibly due to obstruction to aqueous outflow by the microfilaria.

Since the ocular changes due to onchocerciasis are by and large irreversible, early treatment of the disease is required to prevent these changes and the resulting sight impairment or blindness. Ivermectin is now the treatment of choice for Onchocerciasis.

Loiasis, which is caused by the *Loa loa* filarial worm, occurs in West and Central Africa.

The worm has a similar life cycle to *Onchocerca volvulus*, and often causes inflammation involving the eye, although not usually uveitis. *Loa loa* worms are often seen under the conjunctiva, and may be removed with forceps after instilling local anaesthetic and incising the conjunctiva at the appropriate site. An acute localised inflammatory response to the worms is recognised, and has been called 'Calabar swelling'. This commonly occurs in the orbit or eyelids, with a dramatic presentation, but with resolution to normal in a few days. Treatment is with diethylcarbamazine.

## RETINOBLASTOMA

Retinoblastoma is the most common primary, malignant intraocular tumour of childhood. If left untreated it is lethal. The long-term survival rate for retinoblastoma is over 90% in the developed world. The prognosis in developing countries continues to be poor because of late diagnosis and intervention (Fig. 27.30).

### Epidemiology

Retinoblastoma occurs equally in males and females. There is no racial predilection.

60–70% of tumours are unilateral and the mean age at diagnosis is 24 months. 30–40% are bilateral, with a mean age at diagnosis of 14 months. Only 6% of patients have a family history of retinoblastoma. Inheritance is autosomal



**Fig. 27.30:** Retinoblastoma with orbital extension

dominant. The predisposing gene (*RPE1*) is at 13q14. Sporadic cases constitute about 94% of all patients with retinoblastoma.

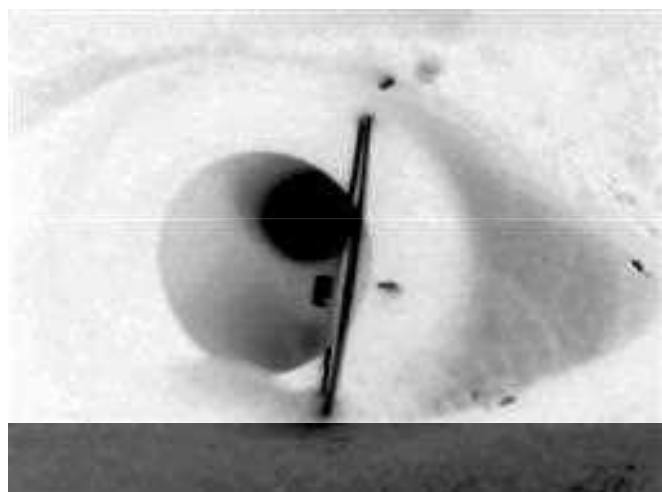
### Clinical Presentation

The possibility of retinoblastoma should be considered with any lesion in the posterior segment of a child less than 5 years of age. Presenting features include:

- Leukocoria (a white pupil reflex)—most common (Box 27.8; Fig. 27.31)

#### Box 27.8: Differential diagnosis of a white pupil

- Retinoblastoma
- Cataract
- Retinal detachment
- Severe posterior uveitis
- Retinopathy of prematurity
- Persistent hyperplastic primary vitreous
- Retinal dysplasia (Norrie's disease)
- Coats' disease



**Fig. 27.31:** Leukocoria and hyphema due to retinoblastoma

- Strabismus—due to a macular lesion causing reduced vision
- Uveitis—with a tumour hypopyon (tumour cells or white blood cells in the anterior chamber)
- Glaucoma—where an eye filled by tumour has raised intraocular pressure
- Hyphaema (red blood cells in the anterior chamber)
- Orbital cellulitis—due to tumour necrosis and inflammation
- Nystagmus
- Proptosis on routine examination—least common.

## Diagnosis

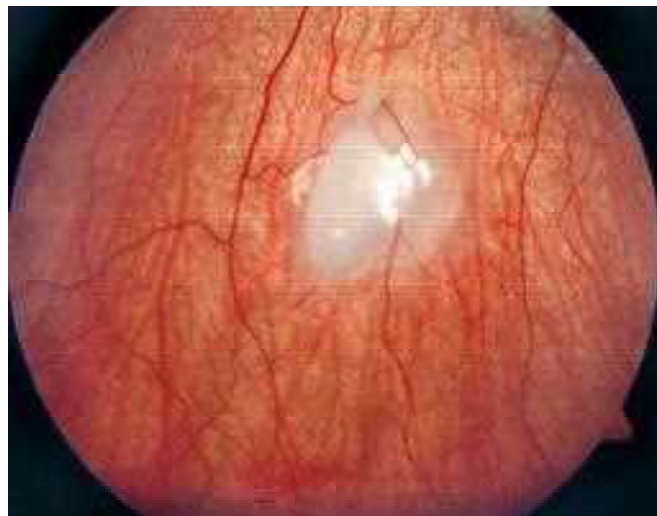
Indirect ophthalmoscopy with scleral indentation must be done on both eyes after full mydriasis. Appearances depend on the size of the tumour and on its pattern of growth. Multiple tumours may be present in the same eye.

## Clinical Findings

- An intraretinal tumour is a flat or round grey to white lesion, fed and drained by dilated tortuous retinal vessels.
- An endophytic tumour projects from the retinal surface as a white, friable mass and may have vitreous seeding.
- An exophytic tumour grows into a cauliflower-like white mass, often associated with a retinal detachment and vitreous haemorrhage.
- As the tumour expands, it undergoes necrosis with areas of calcification (Figs 27.32 and 27.33).

## Special Investigations

*Ultrasonography:* Detects calcification and enables measurement of the tumour dimensions.



**Fig. 27.33:** Exophytic retinoblastoma with surrounding chorioretinal atrophy

*CT scan:* Detects calcification, gross involvement of the optic nerve, extension to the orbit or central nervous system and the presence or absence of pinealoblastoma.

*MRI:* Provides the optimum means of evaluation of the optic nerve and of the detection of pinealoblastoma.

*Differential diagnosis:* This includes persistent hyperplastic primary vitreous, toxocara granuloma, Coats' disease, retinopathy of prematurity, retinal dysplasia.

*Natural history:* As the tumour grows, the globe is gradually filled with tumour, which then expands further and involves the periocular tissues. It then extends intracranially. Blood-borne metastases to distant sites can occur.

## Histologic Features

Retinoblastoma consists of cells with round, oval or spindle-shaped nuclei, which are hyperchromatic and surrounded by scanty cytoplasm.

*Flexner-Wintersteiner rosettes:* These are a characteristic feature of retinoblastoma. A single layer of columnar cells surrounds a central lumen lined by a retractile structure, corresponding to the external limiting membrane of the retina.

*Homer-Wright rosettes:* These do not show features of retinal differentiation and are found in other neuroblastic tumours also.

*Fleurettes:* Are curvilinear clusters of cells composed of rod and cone inner segments that are frequently attached to abortive outer segments.

*Trilateral retinoblastoma:* This term refers to bilateral retinoblastoma with ectopic intracranial retinoblastoma, usually located in the pineal gland or the parasellar region.

*Treatment:* Management of retinoblastoma is highly

tumour location, tumour staging, visual prognosis, systemic involvement and cost-effectiveness. Decisions regarding treatment should be made after detailed discussion with the child's family, who should be involved at all stages of management.

1. Focal therapy: Laser photocoagulation, transpupillary thermotherapy (TTT), cryotherapy, plaque brachytherapy.
2. Local therapy: External beam radiotherapy (EBRT), enucleation.
3. Chemotherapy: It reduces tumour size and makes it more amenable to laser, cryotherapy, TTT or radiotherapy. Chemotherapy followed by focal treatment is the primary treatment of choice for intraocular retinoblastoma.
4. Primary enucleation: It is still indicated for advanced intraocular retinoblastoma, especially in unilateral cases.

On histopathological examination, infiltration of the uvea, sclera and optic nerve beyond the lamina cribrosa imply a high risk of metastasis. Such patients need chemotherapy or radiotherapy. Various combinations of chemotherapeutic drugs are used, the most frequently used agents being vincristine, etoposide and carboplatin.

Genetic counselling is an important part of the management of retinoblastoma.

*Follow-up:* Children with unilateral disease should be followed up at least until 5 years of age. Those with familial or genetically transmitted disease should undergo life-long follow-up.

## RETINOPATHY OF PREMATURITY

Retinopathy of prematurity is a proliferative retinopathy affecting premature infants of low-birth weight and young gestational age. Despite improvements in detection and treatment, ROP remains a leading cause of lifelong visual impairment among premature children.

The International Classification of Retinopathy of Prematurity (ICROP) provides standards for the clinical assessment of ROP on the basis of severity (stage) and anatomical location (zone) of disease.

### Location

**Zone I:** Posterior retina within a 60° circle centered on the optic nerve.

**Zone II:** From the posterior circle (Zone I) to the nasal ora serrata anteriorly.

**Zone III:** The remaining temporal peripheral retina.

*Extent:* Number of clock hours involved.

### Severity

**Stage 1:** A demarcation line between vascularised and non-

**Stage 2:** The presence of a demarcation line that has height, width, and volume (ridge).

**Stage 3:** A ridge with extraretinal fibrovascular proliferation.

**Stage 4:** Subtotal retinal detachment, e.g. (A) extrafoveal (B) retinal detachment including the fovea.

**Stage 5:** Total retinal detachment.

Ophthalmic evaluation of the premature infant may be performed in the nursery or in the office. Examination of the anterior segment is performed with a hand light, with specific attention to the iris vessels, lens and tunica vasculosa lentis. Ophthalmoscopy is performed with an indirect ophthalmoscope and a 28D or 30D condensing lens with scleral indentation when indicated.

Screening for ROP should be performed in all infants with a birth weight with less than 1500 g or a gestational age of 28 weeks or less, as well as infants weighing between 1500 g and 2000 g with an unstable clinical course and who are believed to be at high risk (Figs 27.34 and 27.35).

## Differential Diagnosis

Retinoblastoma, familial exudative vitreoretinopathy, Norrie's disease, X-linked retinoschisis, incontinentia pigmenti.

## Treatment

The ultimate goals of treatment of threshold ROP (stage 3 ROP, zone I or zone II, with at least 5 continuous or 8 total clock hours of disease) are prevention of retinal detachment or of scarring, and optimisation of visual outcome.

## Treatment Options

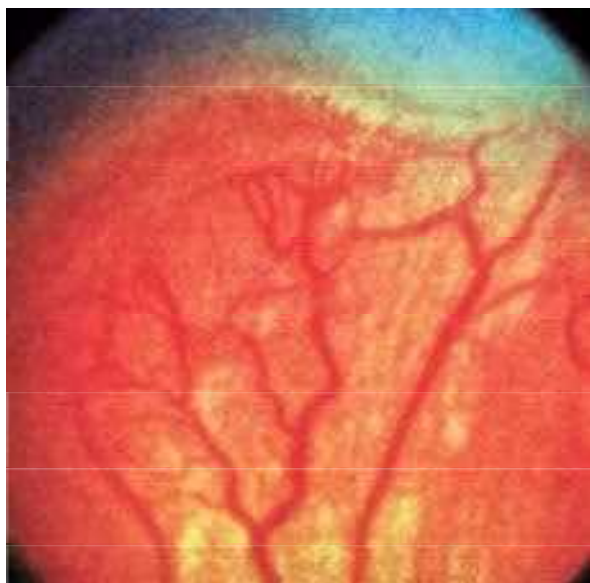
- Cryotherapy
- Laser photocoagulation
- Surgery.

Threshold or pre-threshold ROP can be treated with laser therapy or retinal cryoablation. Laser therapy is preferred over retinal cryoablation. The treatment is applied in full scatter fashion to the avascular anterior retina with the indirect ophthalmoscope. Laser therapy is believed to be less traumatic systemically than cryoablation; it also appears to yield a better visual outcome.

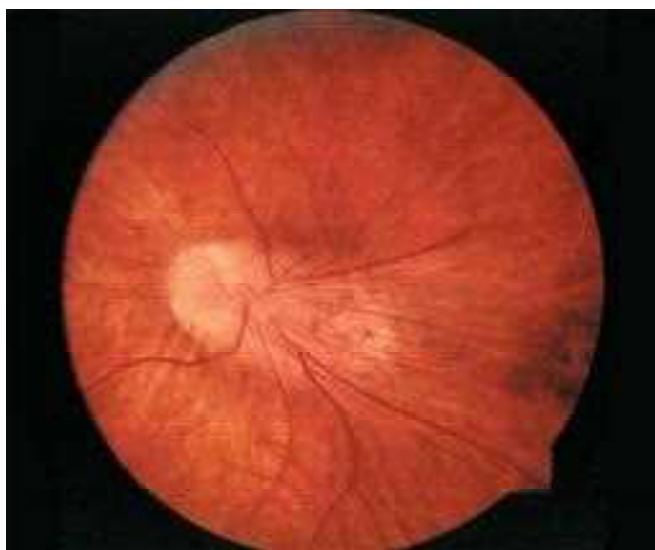
Surgery may be undertaken for patients with Stage 4 and Stage 5 ROP. The modalities commonly used are scleral buckling and vitrectomy, which relieve the tractional components of the retinal detachment.

Certain problems are more likely to occur in eyes with regressed ROP, including myopia with astigmatism, anisometropia, strabismus, amblyopia, cataract, glaucoma and retinal detachment.

It is important to remember that the sequelae of advanced ROP can cause problems throughout the patient's life, and



**Fig. 27.34:** Retinopathy of prematurity: Peripheral retinal vessel proliferation and ridge



**Fig. 27.35:** Retinopathy of prematurity: long-term outcome

## TRAUMATIC RETINOPATHY

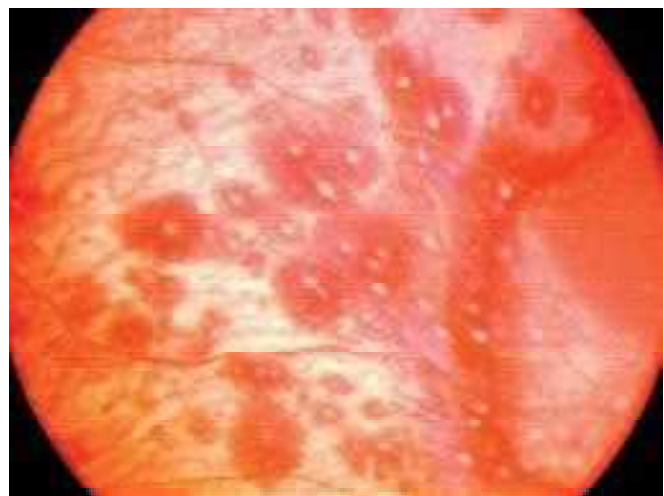
Retinal haemorrhages concentrated at the macula, or spread extensively over the whole retina, sometimes with the presence of Roth's spots (circular haemorrhages with white centres) can be caused in the first two years of life by head injury, for example following road traffic accident. However, such retinal haemorrhages are characteristically seen, sometimes accompanied by subdural haematoma and bruising or injuries elsewhere, in what has been termed the shaken baby syndrome. This terminology is best reserved for

beyond doubt, and the term 'traumatic retinopathy' used at all other times, as a descriptor, as other causes such as a coagulation defect must be considered and ruled out. Retinal haemorrhages due to birth injury seldom persist for longer than one month (Figs 27.36 and 27.37).

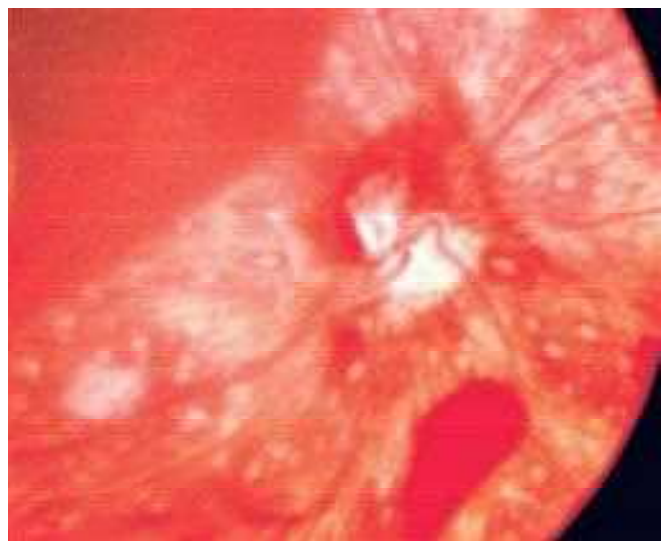
## PREVENTIVE OPHTHALMOLOGY

### Childhood Blindness

The WHO definition of blindness is a best-corrected visual acuity of less than 3/60 in the better eye or a field of vision less than 10 degrees. Visual impairment is graded according to intermediate levels of visual acuity less than 6/18. It is estimated that there are about 5 million visually impaired children in the world. Of these, approximately 1.5 million



**Fig. 27.36:** Retinal haemorrhages in traumatic retinopathy



are blind or severely visually impaired, and approximately 1 million of them live in Asia.

### Causes of Childhood Blindness

The important causes of preventable childhood blindness in the developing world are vitamin A deficiency, measles, ophthalmia neonatorum, glaucoma, cataract, refractive error, squint, retinopathy of prematurity, trachoma and rubella. Onchocerciasis continues to be a problem in Africa and in parts of the Middle East.

Timely and appropriate intervention in vitamin A deficiency is crucially important in the prevention of blindness in individual patients and, since the condition remains a major public health problem in children (with potentially many years of life ahead) in the developing world, widespread measures of prevention could significantly reduce the burden of blindness, in terms of blind person-years, in these societies.

## THE CHILD WITH VISUAL IMPAIRMENT

Vision is required to:

- Access 'information' in the distance. (It is largely through vision that we learn about the environment).
- Access to near information. (For example, playing with toys and looking at and reading books).
- Interacting socially. (Recognising people and their facial expressions and gestures).
- Guiding movement of the upper limbs. (Picking anything up is usually by means of vision in the sighted person).
- Guiding movement of the body. (Walking over steps or in a crowd is mediated through vision to give visual guidance).

In children, vision is required to learn these attributes.

Visual impairment can restrict such learning because it imposes limitations on performance.

It is, therefore, essential to measure all aspects of vision and to understand how each child's visual impairment is impacting upon their development. This knowledge is then employed to implement appropriate strategies to minimise the adverse impact of poor vision.

Poor acuity may not impede mobility but can profoundly affect learning if educational material is not enlarged, and can limit social interaction, if friends and relatives are not aware of this.

Visual field impairment may not significantly impair access to information and social interaction but can significantly impair mobility.



**Fig. 27.38:** Magnifying aids for reading with visual impairment (Traveler + portable video magnifier, available from Optelec-[www.optelec.com](http://www.optelec.com))

### Explaining Poor Vision to Parents and Carers

The diagnosis of visual impairment in a child is distressing. The information is conveyed with care and sensitivity, making and giving the requisite time.

Not only do parents and carers need to understand the child's diagnosis and treatment, but if vision is impaired a detailed analysis of how this can adversely impact on day to day life is required, followed by a structured programme for each child, aimed at ensuring that development is not impaired and education is optimised. This may require magnifying aids and the provision of educational material, which is designed either for visual impairment or blindness as appropriate for each child (Fig. 27.38).

## BIBLIOGRAPHY

1. Basic and Clinical Science Course, American Academy of Ophthalmology, 2004-2005.
2. David Taylor, Paediatric Ophthalmology, 2nd Edition, 1997. Blackwell Science Ltd.
3. Honover SG, Singh AD. Management of Advanced Retinoblastoma, Ophthalmol Clin N.
4. John Sandford-Smith. Eye Diseases in Hot Climates, J W Arrowsmith Ltd, Bristol, 1986.
5. Kenneth W Wright. Paediatric Ophthalmology and Strabismus, Mosby-Year Book, Inc.1995.
6. Myron Yanoff, Jay S. Duker. Ophthalmology – 2nd Edition 1997, Vol. 2, Mosby, Inc.
7. Principles and Practice of Ophthalmology, 2nd Ed, 2000, Jakobeic: Philadelphia, WB Saunders; 2000.

# Haematological Investigations in Children

The haematology laboratory is able to perform a number of tests to help establish the cause of illness in children. The full blood count (FBC, also known as a complete blood count—CBC) is one of the most basic blood tests performed on children attending hospital, or a primary care clinic. All doctors should, therefore, have an understanding of how the test is performed, possible pitfalls, be able to interpret results, and know when more specialised testing or advice is required. Other haematological investigations in routine use include coagulation screens, blood film examination, reticulocyte counts and methods for estimation of iron stores, and detection of abnormal haemoglobins. This section will focus on these basic tests and simple algorithms for the subsequent investigation, and differential diagnosis of the commonest haematological abnormalities encountered in general paediatric practice. The reader is referred to Chapter 15 for an account of the clinical presentation and management of primary haematological disorders in children.

## FULL BLOOD COUNT

The FBC is a numerical estimate of the number of red cells, platelets and white cells in a given sample of blood along with measurement of the haemoglobin concentration, and various red cell indices some of which are directly measured and others derived. Blood is collected into an anticoagulant solution (usually EDTA), and transported to the laboratory. Although counting of each component can be done manually, it is now routine using automated counters in almost all haematology laboratories. These counters recognise cells on the basis of size and physical characteristics. There are two main methods (often used in conjunction). Electrical impedance measurement is based on the fact that blood cells are very poor conductors of electricity. Therefore, when cells in a conducting medium are made to flow in single file through an aperture across which an electric current flows, there is a measurable increase in electrical impedance which is proportional to the volume of the cell. In this way, cells

can be both counted and sized. The second method relies on characteristic patterns of light scatter and absorbance as cells pass through a laser beam; this is particularly useful for the recognition and counting of the different types of white blood cell (to produce a white cell differential count). In addition, counters estimate haemoglobin by lysing the red blood cells and measuring the optical density of the resulting solution at an appropriate wavelength. A typical readout from an automated counter is shown in Figure 28.1.

### Key Learning Points

- ➔ Automated blood counters identify cells on the basis of size and laser light scatter patterns. Haemoglobin concentration is measured by lysis of red blood cells and measuring the optical density of the resulting coloured solution
- ➔ Because automated machines rely on size as one way to classify cells, it is possible to get artefactual results in some situations. For example, nucleated red blood cells are often counted as white cells, and fragmented red cells are counted as platelets. Any unusual count should be checked manually with a blood film.

## RED CELL INDICES

In addition to the red cell count and haemoglobin concentration, it is clinically useful to know the size of red cells (mean cell volume, MCV); the amount of haemoglobin per cell (mean cell haemoglobin, MCH), and a measure of the variation in size of individual red cells (red cell distribution width, RDW). Collectively, these values are known as red cell indices. They are particularly useful in the assessment of likely causes of anaemia (see below).

## BLOOD FILM

Examination of a stained blood film is an essential part of the assessment of most haematological disorders. Many



WBC	5.65	[10 <sup>9</sup> /L]		
RBC	4.88	[10 <sup>12</sup> /L]		
HGB	14.2	[g/dl]		
HCT	41.5	[%]		
MCV	85.0	[fL]		
MCH	29.1	[pg]		
MCHC	34.2	[g/dl]		
PLT	303	[10 <sup>9</sup> /L]		
RDW-SD	38.5	[fL]		
RDW-CV	12.7	[%]		
PDW	10.8	[fL]		
MPV	9.4	[fL]		
P-LCR	21.2	[%]		
PCT	0.25	[%]		
NEUT	2.73	[10 <sup>9</sup> /L]	48.4	[%]
LYMPH	2.33	[10 <sup>9</sup> /L]	41.2	[%]
MONO	0.45	[10 <sup>9</sup> /L]	8.0	[%]
EO	0.11	[10 <sup>9</sup> /L]	1.9	[%]
BASO	0.03	[10 <sup>9</sup> /L]	0.5	[%]
RET	0.60	[%]	29.3	[10 <sup>9</sup> /L]
IRF	1.4	[%]		
LFR	98.6	[%]		
MFR	0.7	[%]		
HFR	0.7	[%]		

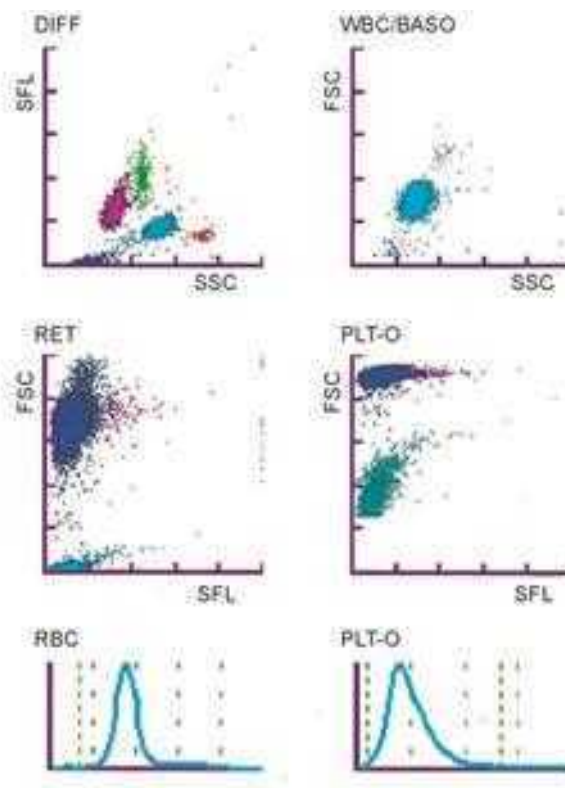


Fig. 28.1: A typical computer generated readout from an automated blood cell analyser (Sysmex XT2000i)

haematological diseases have characteristic changes. In some cases, it is possible to diagnose a disorder purely from the blood film (e.g. hereditary elliptocytosis); in most cases, other confirmatory tests are needed. The blood film may be very useful in identifying artefactual results, such as thrombocytopenia caused by platelet clumping. Systemic disease may also produce blood film changes, for example, sepsis may be accompanied by an increase in immature neutrophils (left shift or band forms), toxic granulation, and formation of Döhle bodies (pale blue cytoplasmic inclusions) within neutrophils. These latter changes are particularly useful in assessment of neonates. Figures 28.2A to G show some of the characteristic red cell changes seen on the blood film along with common causes for these appearances.

### RETICULOCYTE COUNT

Reticulocytes are young red cells that have lost their nucleus, but still contain substantial amounts of ribosomal RNA leading to their characteristic bluish purple colour on standard haematoxylin and eosin (H&E) staining of blood films. They can be more easily identified using special stains, such as new methylene blue, and can be counted manually or on some automated counters. They can be expressed as

a percentage of the total red cells, or an absolute count. Reticulocyte numbers are very useful in the evaluation of anaemia, as they allow a distinction to be made between inadequate marrow production of red cells (associated with a low reticulocyte count) and excessive destruction or loss of red cells in the periphery (usually associated with increased reticulocyte release from the marrow).

### NORMAL RANGES

The synthesis of blood cells and coagulation proteins go through various changes during development (discussed further in Chapter 15). This is particularly marked in the neonatal period and early infancy because of adaptive changes needed for the transition between the uterine microenvironment and the outside world. Therefore, when interpreting any haematological value, it is important to be aware of age appropriate normal ranges. Table 28.1 gives approximate values for the FBC from birth to adulthood. Normal ranges should ideally be determined using the local population and the actual instruments in everyday use in the laboratory. In paediatrics, it is difficult to obtain sufficient numbers of samples from healthy controls and therefore, estimates are usually made using published normal ranges.

**Key Learning Points**

- Normal ranges vary with age, especially in infants. Always interpret results in light of age appropriate normal ranges.
- Haemoglobin values are high at birth, then fall to a nadir at around 3 months of age before slowly rising again.
- Infants and children up to the age of 4 years, have a relative lymphocytosis.

## INVESTIGATION OF LOW HAEMOGLOBIN IN INFANCY AND CHILDHOOD

Although there are a multitude of causes for anaemia in this age range, the majority of causes can be ascertained by logical use of relatively few tests. An initial history should focus on the length and speed of onset of symptoms, dietary history, ethnic origin, any other medical conditions, and any family history of blood disorders. When considering the differential diagnosis for any haematological disorder, it is useful to divide the causes into those due to underproduction of cells from the bone marrow, those due to peripheral destruction of cells, and those due to loss of cells from the circulation (haemorrhage or sequestration). A simple way to narrow down the list of differential diagnoses for anaemia is to look at the red cell indices. There are a limited number of causes of a hypochromic microcytic anaemia, or a macrocytic anaemia—the common causes are listed in Table 28.2. When assessing a normocytic anaemia, a reticulocyte count is useful to distinguish between marrow production problems and peripheral destruction or haemorrhage. The blood film may also be useful with characteristic changes seen in some red cell haemoglobin or enzyme disorders (see Figs 28.2A to G).

**Key Learning Points**

When formulating a differential diagnosis for low blood counts (red cells, white cells or platelets), always consider the following mechanisms:

- Reduced production of cells
  - Disorders interfering with normal haemopoiesis, such as nutritional deficiency or aplastic anaemia
  - Primary bone marrow failure syndromes
  - Secondary marrow infiltration
- Peripheral destruction of cells
- Loss from the body (e.g., haemorrhage) or sequestration within the tissues or organs.

## HYPOCHROMIC MICROCYTIC ANAEMIA

The main differential diagnosis is between iron deficiency and thalassaemia. Thalassaemia major presents in early infancy with a transfusion dependent anaemia, and characteristic blood film and electrophoretic findings (absent haemoglobin A), and usually presents little diagnostic difficulty. Thalassaemia trait does not produce significant anaemia alone, but does give hypochromic microcytic indices often in association with a raised red cell count but relatively normal RDW. In contrast, iron deficiency usually gives a low red cell count but a raised RDW (this being a measure of variation in red cell width and therefore, raised in the presence of anisocytosis). The blood film is often helpful.

Beta thalassaemia trait is characterised by basophilic stippling (see Figs 28.2A to G). Alpha thalassaemia trait has few characteristic features. Iron deficiency gives marked anisopoikilocytosis with hypochromic red cell fragments, pencil and teardrop cells, and frequent accompanying thrombocytosis (Figs 28.2A to G).

**Table 28.1:** Normal ranges for the FBC in infancy and childhood

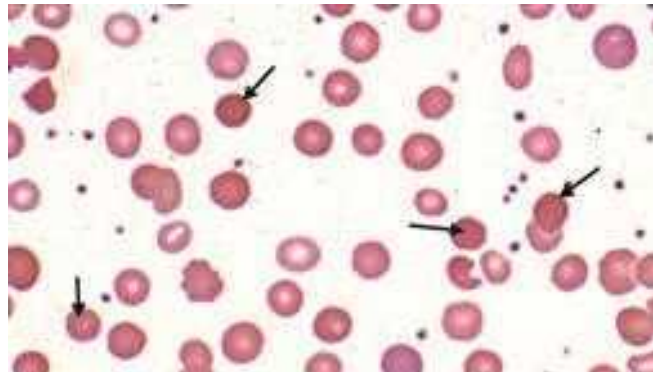
Age	Haemoglobin (g/dl)	Hct	MCV (fl)	WBC ( $\times 10^9/l$ )	Neutrophils ( $\times 10^9/l$ )	Lymphocytes ( $\times 10^9/l$ )	Monocytes ( $\times 10^9/l$ )	Eosinophils ( $\times 10^9/l$ )	Basophils ( $\times 10^9/l$ )	Platelets ( $\times 10^9/l$ )
Birth (term infants)	14.9–23.7	0.47–0.75	100–128	10–26	2.7–14.4	2.0–7.3	0–1.9	0–0.85	0–0.1	150–450
2 weeks	13.4–19.8	0.41–0.65	88–110	6–21	1.5–5.4	2.8–9.1	0.1–1.7	0–0.85	0–0.1	170–500
2 months	9.4–13.0	0.28–0.42	84–98	5–15	0.7–4.8	3.3–10.3	0.4–1.2	0.05–0.9	0.02–0.13	210–650
6 months	10.0–13.0	0.3–0.38	73–84	6–17	1–6	3.3–11.5	0.2–1.3	0.1–1.1	0.02–0.2	210–560
1 year	10.1–13.0	0.3–0.38	70–82	6–16	1–8	3.4–10.5	0.2–0.9	0.05–0.9	0.02–0.13	200–550
2–6 years	11.0–13.8	0.32–0.4	72–87	6–17	1.5–8.5	1.8–8.4	0.15–1.3	0.05–1.1	0.02–0.12	210–490
6–12 years	11.1–14.7	0.32–0.43	76–90	4.5–14.5	1.5–8.0	1.5–5.0	0.15–1.3	0.05–1.0	0.02–0.12	170–450
12–18 years female	12.1–15.1	0.35–0.44	77–94							
12–18 years male	12.1–16.6	0.35–0.49	77–92	4.5–13	1.5–6	1.5–4.5	0.15–1.3	0.05–0.8	0.02–0.12	180–430

Source: Reproduced from In: Arceci, Hann & Smith (Eds). Pediatric haematology, 3rd edition. Blackwell Publishing; 2006.

**Finding**

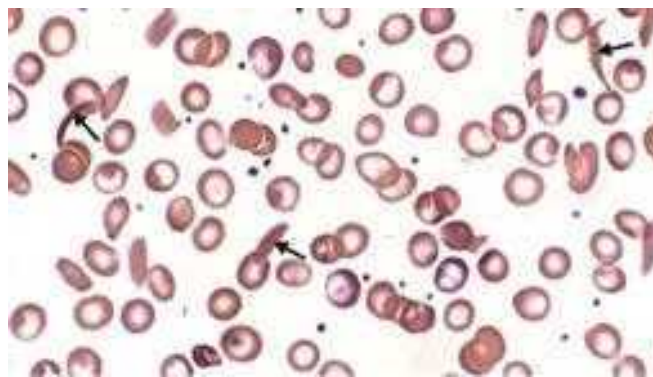
**Causes**

A. Spherocytes



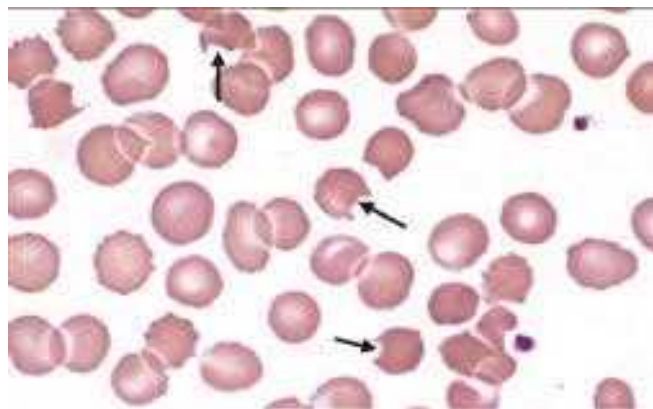
Autoimmune haemolytic anaemia, hereditary spherocytosis, haemolytic disease of the newborn

B. Sickle cells



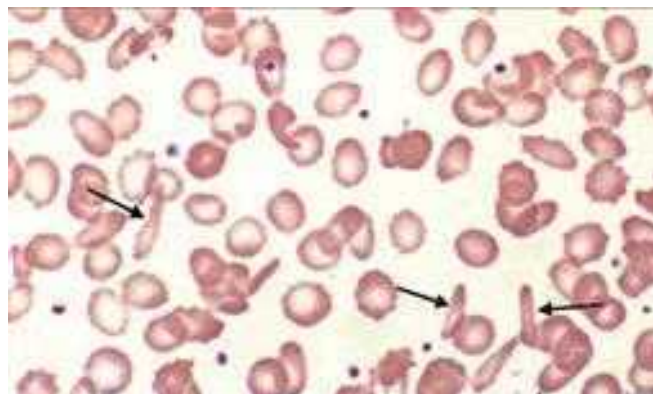
Sickle cell anaemia (HbSS/HbSC)

C. Bite cells



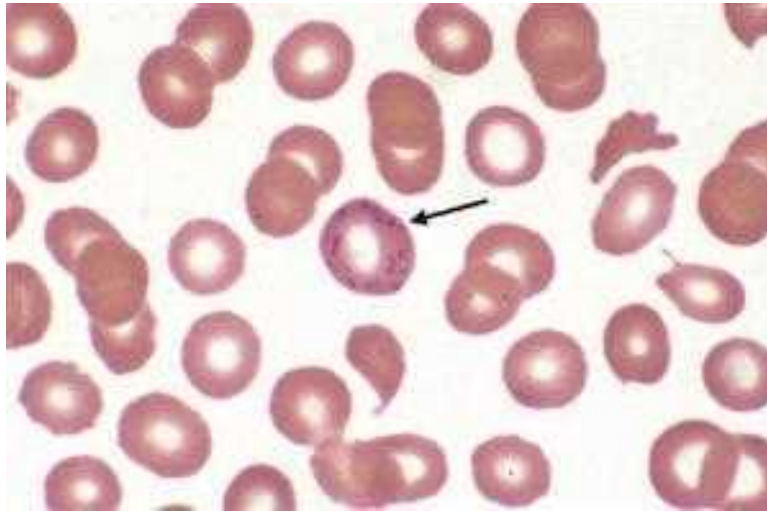
G6PD/oxidative damage

D. Pencil cells



Iron deficiency

E. Basophilic stippling



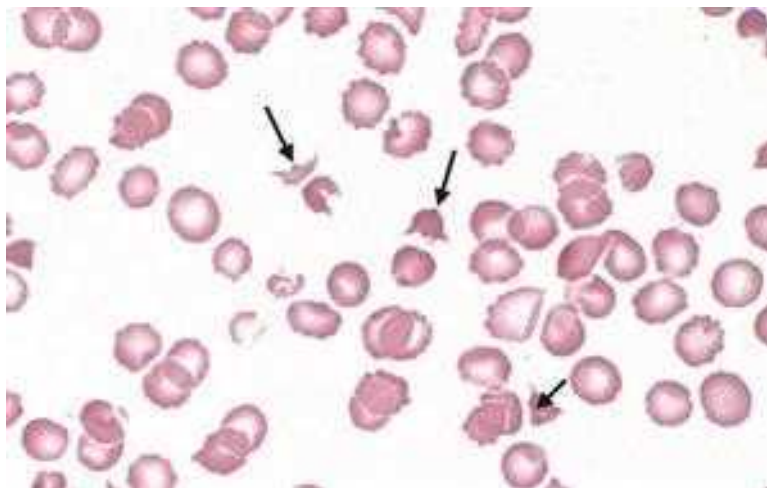
B Thalassaemia trait, lead poisoning

F. Target cells



Iron deficiency, liver disease, sickle cell anaemia (particularly HbSC disease), B thalassaemia, hyposplenism

G. Red cell fragments



Microangiopathic haemolytic anaemia, iron deficiency (hypochromic fragments)

**Figs 28.2A to G:** Red cell changes seen on blood films and their common causes; (A) Spherocytes; (B) Sickle cells; (C) Bite cells; (D) A pencil cell; (E) Basophilic stippling; (F) Target cells; (G) Red cell fragments. Arrows point to the abnormal cell type

## TESTS TO DIAGNOSE IRON DEFICIENCY

An inadequate iron supply will initially lead to depletion of iron stores followed by iron deficient erythropoiesis and finally, the development of anaemia (Fig. 28.3). Serum ferritin is the first marker of depleted iron stores in the body. It is diagnostic if low, but false negative results can be seen because ferritin is an acute phase reactant and therefore, can be elevated with acute inflammation or infection even in the presence of iron deficiency. As iron deficiency progresses, the transferrin (measured as total iron binding capacity—TIBC) becomes elevated with reduced serum iron. The ratio of these two results can be expressed as the transferrin saturation. Immediate precursors of haem accumulate zinc (free erythrocyte) protoporphyrin). Finally, a hypochromic microcytic anaemia develops. Other tests include measurement of soluble transferrin receptors (increased in iron deficiency). The gold standard test remains Perls' staining of a particulate bone marrow biopsy specimen for iron but this is rarely necessary.

## TESTS TO DIAGNOSE THALASSAEMIA

In order to understand tests for thalassaemia properly, it is necessary to be aware of the composition of haemoglobin and the developmental changes that occur in the use of various globin chains; these are discussed in Chapter 15. Diagnosis of thalassaemia is usually made by tests that separate the haemoglobin molecules on the basis of electrical charge; this allows quantitation of the normal haemoglobins HbA ( $\alpha_2\beta_2$ ), HbA<sub>2</sub> ( $\alpha_2\delta_2$ ) and HbF ( $\alpha_2\gamma_2$ ), and also detection

of abnormal haemoglobins that contain amino acid changes which alter charge (such as sickle cell HbS). The two main methods in use are haemoglobin electrophoresis and high performance liquid chromatography (HPLC). Beta thalassaemia major can be diagnosed by the complete absence of haemoglobin A on haemoglobin electrophoresis, provided the test is performed before transfusion of the patient. Beta thalassaemia trait usually shows an elevated HbA<sub>2</sub> level above 3.5% (normal ranges will vary from lab to lab); care should be taken in the presence of iron deficiency as this may reduce the HbA<sub>2</sub> level back into the normal range—results should be repeated after iron replacement in any iron deficient individual. Alpha thalassaemia major is usually diagnosed antenatally, or at the time of birth of a severely hydropic infant since all the normal haemoglobins present at birth contain  $\alpha$ -chains. Three  $\alpha$  gene deletions, so called HbH disease can be diagnosed by electrophoretic detection of Haemoglobin H ( $\beta_4$  tetramers), or by staining a blood film with brilliant cresyl blue—the  $\beta_4$  tetramers in the red cells are stained dark blue, and produce a golf-ball like appearance. The diagnosis of alpha thalassaemia trait (one or two gene deletions) is suspected by the presence of hypochromia and microcytosis in the absence of iron deficiency, and with a normal HbA<sub>2</sub> measurement. As it does not produce clinically significant disease, definitive diagnostic investigations (genetic testing for individual mutations) are usually reserved for antenatal patients at significant risk of alpha thalassaemia major in their offspring. Diagnostic investigations for thalassaemia are summarised in Table 28.3.

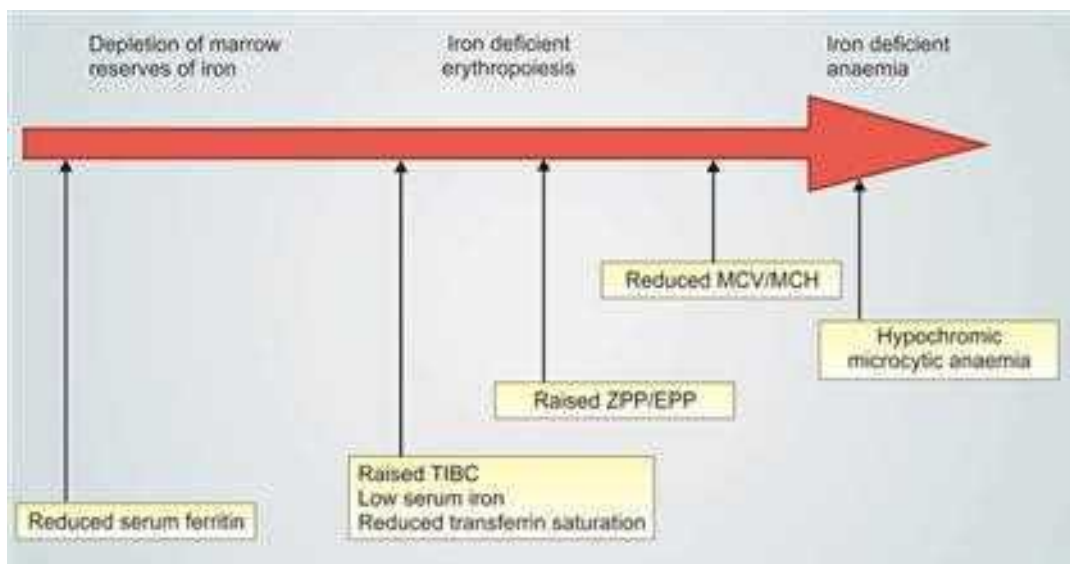


Fig. 28.3: Stages of iron deficiency

**Table 28.2:** Causes of anaemia classified on red cell indices

<i>Hypochromic</i>	<i>Normocytic</i>	<i>Microcytic</i>
Iron deficiency	Haemorrhage (acute)	Vitamin B <sub>12</sub> /Folate deficiency
Thalassaemia	Haemolysis-AIHA	Reticulocytosis
Sideroblastic anaemia	Haemoglobinopathy—sickle cell disease	Myelodysplasia
Chronic disease	Red cell membrane defect—hereditary, spherocytosis	Hypothyroidism
Lead poisoning	Red cell enzyme—G6PD, pyruvate kinase	Drugs
	Marrow infiltration—malignancy, aplastic anaemia, Transient Erythroblastopenia of childhood	Liver disease
	Bone marrow failure syndromes—anaemia of chronic disease	Scurvy

## MACROCYTIC ANAEMIA

The cause of a macrocytic anaemia in children is often obvious from the history. History of concurrent or past illnesses, symptoms and signs of malabsorption, and a detailed drug history are important. B<sub>12</sub> and folate, liver function tests, a reticulocyte count and thyroid function should be measured in unexplained cases. Causes are listed in Table 28.2.

## NORMOCYTIC ANAEMIA

As mentioned above, a reticulocyte count is particularly useful in distinguishing reduced marrow production from increased destruction of red cells. The blood film can also give clues as to the most likely cause and best initial tests. A simple algorithm is given in Figure 28.4.

Haemolytic anaemias are a large subgroup of normocytic anaemias. The combination of jaundice (unconjugated hyperbilirubinaemia), reticulocytosis and anaemia suggests a haemolytic process. Further tests for haemolysis include serum haptoglobin measurement (proteins present in normal plasma which can bind free haemoglobin, and are then removed from the circulation by the reticuloendothelial system), urinary haemosiderin (an iron storage protein derived from the breakdown of free haemoglobin in the renal tubular system), and urobilinogen (a natural breakdown product of bilirubin excreted in the urine). These are summarised in Table 28.4. A key test in establishing the cause of haemolysis is the direct Coombs test (DCT), also called the direct antiglobulin test (DAT). This tests detects the presence of antibody bound to the red cell surface by the use of reagents containing anti-IgG, and anti-complement that cause agglutination of cells, as shown in Figure 28.5. A positive DCT indicates a likely immune cause for the anaemia. If the DCT is negative, then tests for red cell enzyme defects (G6PD and pyruvate kinase assays), haemoglobinopathies (haemoglobin electrophoresis and sickle solubility test), and membrane disorders (demonstration of increased osmotic fragility of cells, protein analysis by SDS-Polyacrylamide gel electrophoresis, or more recent EMA dye binding tests) may need to be performed.

If the reticulocyte count is normal or low, it is likely that the anaemia is due to a problem with red cell production in the marrow. A bone marrow aspirate and trephine (see section on white cell disorders below) may be needed to help establish the cause. Lack of red cell precursors in the marrow can be seen as an isolated phenomenon in transient erythroblastopenia of childhood (TEC), acute parvovirus B19 infection, or inherited red cell aplasia (Diamond-Blackfan anaemia). If part of a pancytopenia, then aplastic anaemia or hypoplastic myelodysplastic syndrome may be the cause. Occasionally, acute leukaemias can present with an aplastic phase followed several weeks to months later by the development of ALL.

**Table 28.3:** Investigation results in thalassaemia

<i>Diagnosis</i>	<i>Genetic defect</i>	<i>Blood film</i>	<i>Haemoglobin electrophoresis</i>
Beta thalassaemia major	2 $\beta$ gene mutations	Severe hypochromic microcytic anaemia, nucleated red cells, target cells	Absent HbA (pretransfusion), high HbF
Beta thalassaemia trait	1 $\beta$ gene mutation	Basophilic stippling, hypochromia and microcytosis but normal or borderline low haemoglobin	Raised HbA <sub>2</sub> >3.5%
Alpha thalassaemia major (incompatible with survival beyond embryonic period)	4 $\alpha$ gene deletions	Very severe anaemia, nucleated red cells	Absent HbA, A2 and HbF Presence of embryonic haemoglobin HbPortland and HbBart's and HbH
Haemoglobin H disease	3 $\alpha$ gene deletions	Anaemia, target cells, teardrop cells and fragments HbH bodies on special staining of film	HbH
Alpha thalassaemia trait	1 or 2 $\alpha$ gene deletions	Hypochromia, microcytosis	2-8% Hb Bart's at birth (may be detected on neonatal screening programmes)

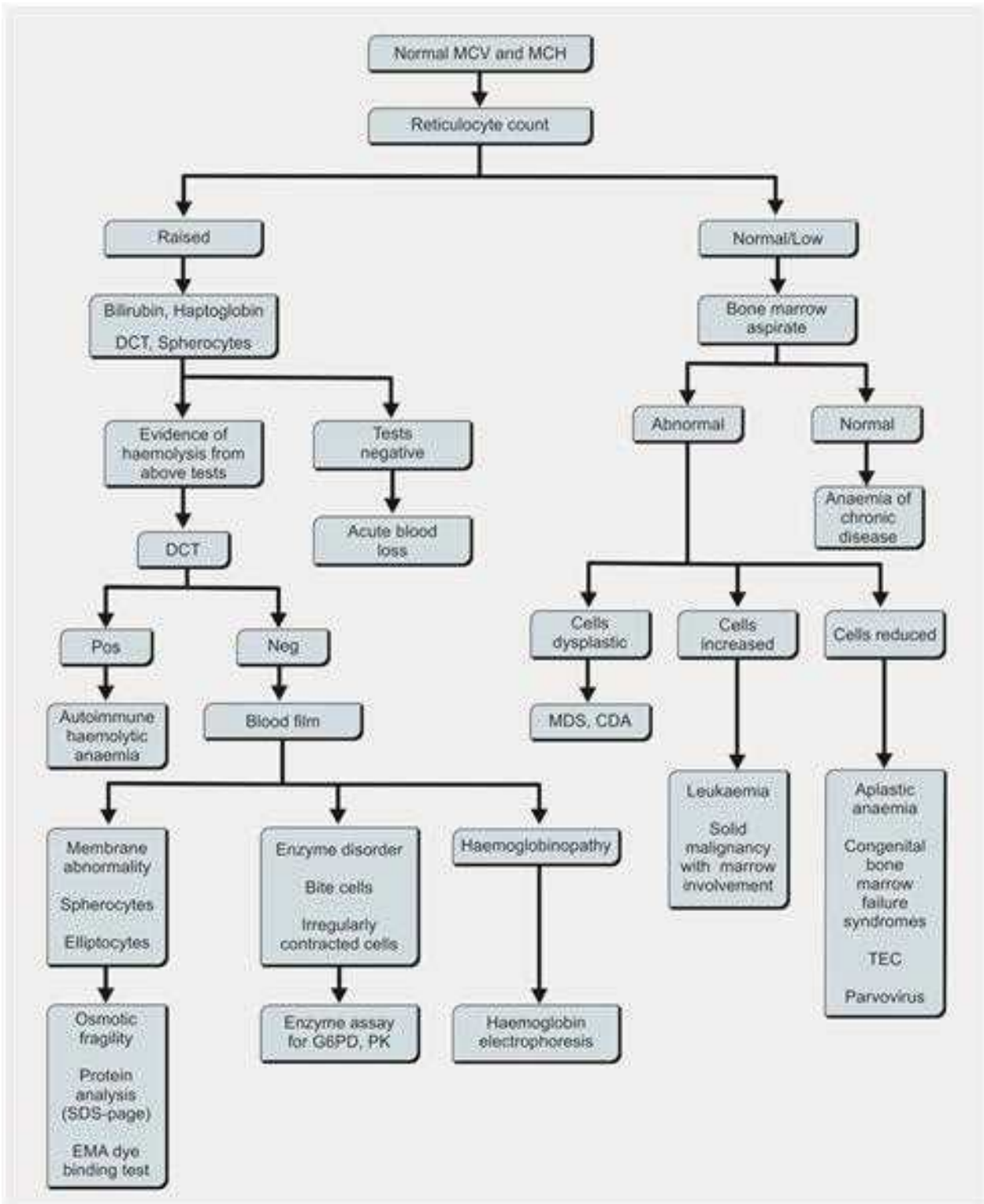


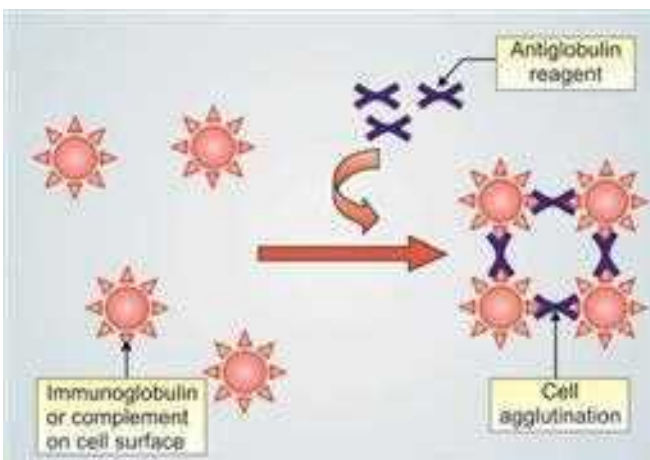
Fig. 28.4: Investigation and causes of normocytic anaemias (DCT = Direct Coomb's test; MDS = Myelodysplasia; CDA = Congenital dyserythropoietic anaemia; TEC = Transient erythroblastopenia of childhood)

**Table 28.4:** Indicators of haemolysis

Due to increased red cell destruction	Raised serum unconjugated bilirubin Raised urinary urobilinogen Reduced plasma haptoglobins
Due to increased red cell production	Raised reticulocyte count
Due to presence of damaged red cells	Abnormal morphology—spherocytes, bite cells, fragments Increased osmotic fragility

## INVESTIGATION OF ANAEMIA IN NEONATES

Anaemia is the commonest haematological abnormality seen in neonates. The spectrum and causes of disease are somewhat different than in older children. There are key differences in red cell physiology in neonates that contribute to the different modes of presentation in this age group. Although the haemoglobin tends to be high initially (due at least in part to haemoconcentration and placental transfusion prior to cord clamping), erythropoiesis is then switched off at the time of birth, and haemoglobin falls to a nadir of around 10 g/dl by the age of 8 weeks. This fall is exaggerated in premature infants—so called anaemia of prematurity. In addition, premature babies are particularly vulnerable to iatrogenic anaemia; secondary to blood loss associated with frequent blood testing. The MCV is high in neonates, and differences in red cell membrane composition can make some haemolytic red cell disorders, such as hereditary pyropoikilocytosis and hereditary spherocytosis—worse in the neonatal period. In contrast, the enzymopathy glucose-6-phosphate dehydrogenase deficiency (G6PD) is not usually associated with significant haemolysis in the newborn period (unless the baby is exposed to oxidant stress), but may present with severe jaundice which is thought to be hepatic in origin. Haemolysis may also be antibody mediated due to Rhesus or ABO incompatibility between mother and infant. Increased

**Fig. 28.5:** The direct Coombs test

red cell destruction puts the baby at risk of kernicterus caused by high bilirubin levels. Hence, it is important to be aware of the possibility of haemolysis in all newborn babies.

Anaemia presenting soon after birth, may also be due to haemorrhage pre, during or post delivery. Feto-maternal haemorrhage can be diagnosed by performing a Kleihauer test on the mother—this test looks for the presence of fetal haemoglobin containing cells in the maternal circulation by virtue of their ability to resist acid elution of haemoglobin. In multiple pregnancies that share a placental circulation, twin-to-twin transfusion may also occur to produce one polycythaemic twin and one anaemic one. An algorithm for the diagnosis of neonatal anaemia is given in Figure 28.6.

### Key Learning Point

➔ The causes and presentation of anaemia are different in neonates due to differences in red cell physiology. It is important to diagnose haemolytic disorders early to reduce the risk of kernicterus.

## POLYCYTHAEMIA

High haemoglobins and haematocrits can be due to increased numbers of red cells (true polycythaemia) or dehydration, leading to a decreased plasma volume (relative polycythaemia). In children, true polycythaemia is usually due to a secondary cause, such as hypoxia from cyanotic congenital heart disease leading to increased erythropoietin production. Occasionally, kidney tumours can secrete erythropoietin. Primary erythrocytosis (a myeloproliferative disease relatively common in adults) is extremely rare in children. Neonates have higher incidences of polycythaemia, usually secondary to placental insufficiency or delayed clamping of the cord. The blood viscosity increases exponentially with haematocrits above 0.65, therefore, these infants are often treated with exchange transfusion—the evidence for benefit from this is lacking.

## WHITE CELL DISORDERS

The white cells in the blood can be subdivided into different subpopulations with distinct functions. These are listed in Table 28.5 along with the main causes of high or low counts for these cells.

### Low White Cell Counts (Leucopenia)

The commonest and most important white cell deficiency is that involving neutrophils (neutropenia) since this can be associated with an increased risk of serious infection. It can be caused by a defect in bone marrow production either affecting this cell type alone (isolated neutropenia), or as part of a general failure of the bone marrow to produce mature



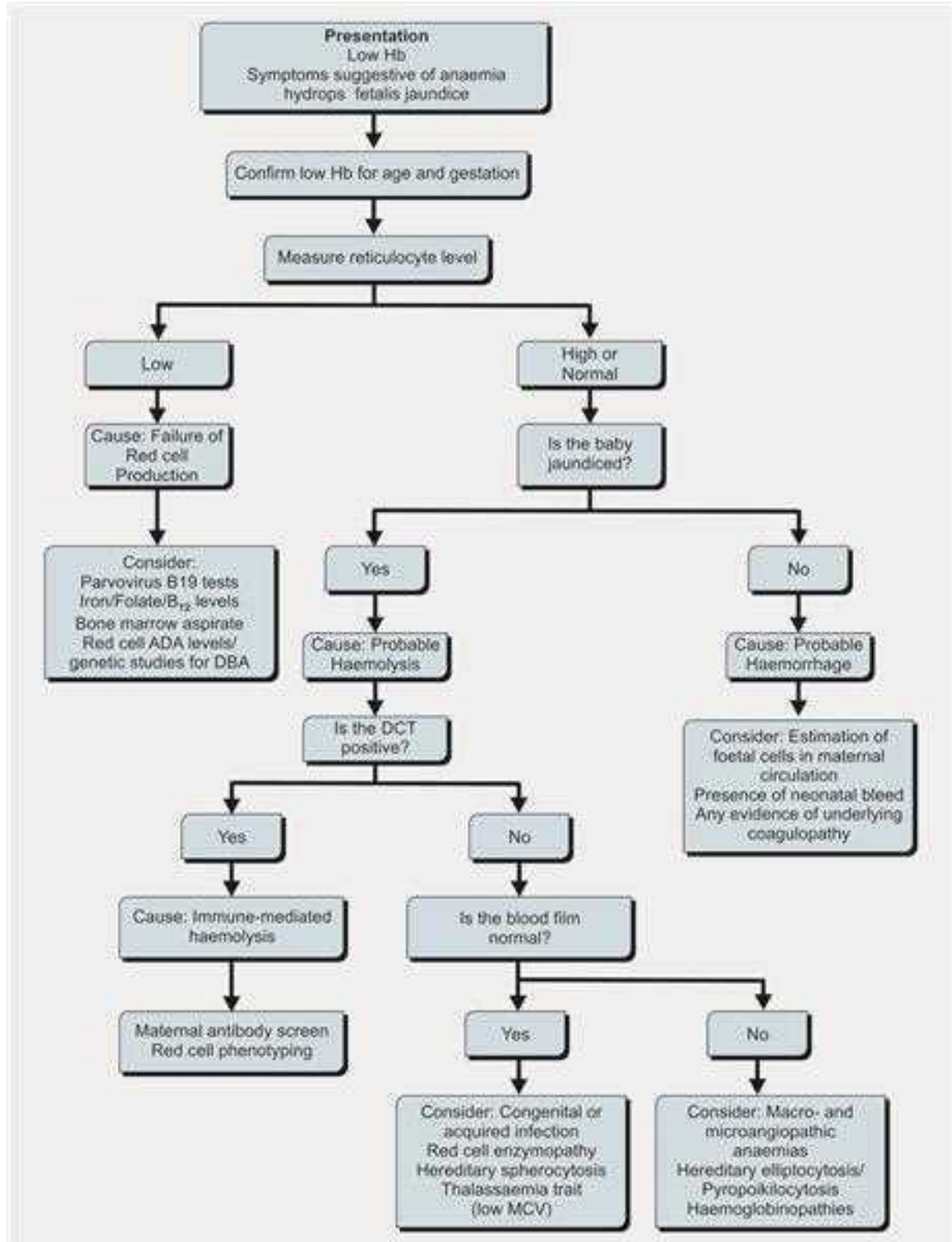


Fig. 28.6: Investigation and causes of neonatal anaemia

**Table 28.5:** White cell types and their disorders

Cell type	Function	Causes of increased count	Causes of decreased count
Neutrophil	Innate immunity, control of bacterial and fungal infection, Role in phagocytosis of dead and damaged cells as part of inflammation	Bacterial infection Inflammatory disorders and tissue necrosis Severe marrow stress- haemorrhage or haemolysis Steroid therapy Myeloproliferative disorder (rare in children)	Infection—viral or fulminant bacterial Autoimmune Marrow failure Drugs African race
Lymphocyte	Adaptive immunity Control of viral infection	Acute infection especially viral, e.g. Epstein Barr virus (glandular fever) Chronic infection—TB, toxoplasmosis Acute leukaemia	Acute stress including acute infection, burns, surgery, trauma Steroids, Cushing's syndrome Immunodeficiency—congenital and acquired including use of immunosuppressive drugs
Monocyte	Part of reticuloendothelial systemmacrophage precursors in transit	Chronic bacterial infections (TB) Lymphoma Juvenile myelomonocytic leukaemia Associated with neutropenia	Marrow failure Drugs
Eosinophil	Inflammatory responses Response to parasitic infection	Parasitic infection Allergy, atopy Skin diseases Hodgkin's disease	Marrow failure Cushing's syndrome Acute stress, e.g. burns Drugs
Basophil	Largely unknown, blood counterpart to tissue mast cell	Chickenpox Myeloproliferative diseases Hypothyroidism Ulcerative colitis	As above

blood cells (pancytopenia). Alternatively, neutropenia can result from peripheral destruction of neutrophils by antibodies or their redistribution to the tissues or sites of injury. Normal ranges for neutrophils vary between ethnic groups, and are particularly low in black Africans. This is thought to represent a different distribution of neutrophils between the tissues and the circulation, rather than an overall lower total body count. Neutrophil numbers circulating in the bloodstream rise after exercise, and as a stress response.

Lymphopenia can follow acute infections, or periods of immunosuppression. Lymphocyte counts are generally higher in neonates. In neonates with lymphopenia and serious infections, the possibility of an inherited immunodeficiency should be borne in mind.

### High White Cell Counts (Leucocytosis)

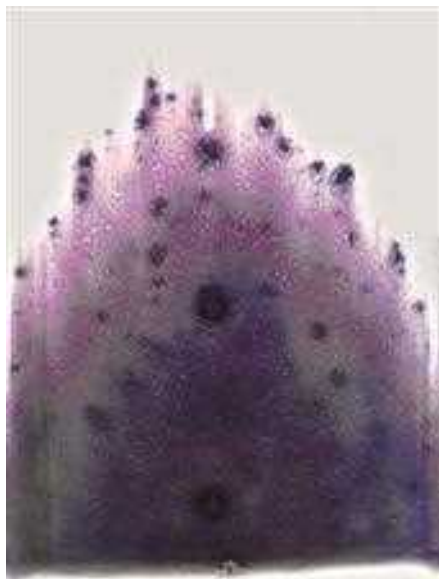
A high neutrophil count often accompanies infection (neutrophilia), and can be a useful marker of sepsis. Very high neutrophil counts, with evidence of immature precursors in the bloodstream, are sometimes called a leukaemoid reaction. This can be seen with overwhelming sepsis, marrow infiltration by a solid malignancy, a severe stress response, such as status epilepticus or burns. Leukaemia itself can present with high or low white cell numbers, and is usually suspected by the combination of an abnormal blood count (white cells high or low, usually with accompanying anaemia and thrombocytopenia) with a blood film that shows a population of immature precursors (blast cells). Blast cells vary in appearance with the different subtypes of leukaemia, but are generally larger than normal cells with a large nuclei

and open chromatin (see Chapter 15, Figs 15.15 and 15.16). Myeloid blast cells may have rod-like inclusions in their cytoplasm called Auer rods.

The definitive diagnosis of leukaemia usually requires bone marrow examination; this allows detailed study of the appearance of the cells (morphology) as well as analysis of various specific proteins expressed by the cells (immunophenotyping), and genetic abnormalities (molecular genetics and cytogenetics) which help classify the leukaemia further and guide treatment.

### BONE MARROW EXAMINATION

Bone marrow examination is performed for further assessment of haematological disorders where production of cells from the bone marrow is thought to be abnormal. In children, it is often performed under general anaesthesia, although, local anaesthetic can be used if appropriate. The usual site for aspiration is the posterior iliac crest. A large bore needle is used to penetrate the bony cortex, and enter the marrow cavity. Bone marrow is then aspirated and spread on glass slides, preferably immediately after. If a good specimen is obtained, then a granular appearance should be seen (Fig. 28.7). Further samples can be taken in appropriate anticoagulant or medium for cytogenetics, immunophenotyping, and molecular genetic tests. In many cases, a bone marrow trephine can also be taken—this involves introducing a longer needle below the cortex, and taking a core of tissue that can then be fixed and sectioned for pathological examination.



**Fig. 28.7:** Example of bone marrow aspirate specimen spread on a slide and stained with H&E; note the granular appearance at the top of the smear

## PLATELET DISORDERS

Platelets are small cytoplasmic fragments produced from megakaryocytes in the bone marrow and are important for the initiation of haemostasis, and may have as yet poorly understood roles in inflammation. As with white and red cells, platelet disorders can be subdivided on the basis of high and low numbers.

### High Platelet Counts (Thrombocytosis)

High platelet counts are usually reactive, i.e. not primary bone marrow disorders, but secondary to iron deficiency, ongoing inflammatory processes or infection. Very high platelet counts ( $>1500 \times 10^9/l$ ) can be associated with an increased risk of thrombosis. Primary thrombocytosis (essential thrombocythaemia) is rare in children.

### Low Platelet Counts (Thrombocytopenia)

Again, these can be classified according to the underlying problem, i.e., inadequate bone marrow production or peripheral destruction/consumption (see Table 15.3, Chapter 15). Unexpectedly, low platelet counts should always be confirmed by examination of a blood film as artefactually low platelet counts are not uncommon either due to partial clotting of the sample or platelet clumping; the latter is often an *in vitro* phenomenon due to EDTA dependent antibodies. The commonest cause of true thrombocytopenia in children is immune mediated peripheral destruction—idiopathic thrombocytopenic purpura (ITP). Unfortunately, there is no

diagnostic test for this condition; so, it remains a diagnosis of exclusion. It is characterised by the sudden onset of bruising and/or bleeding in an otherwise well child, often with a history of an antecedent viral infection, or more rarely post immunisation. There should be no other abnormalities in the blood count, and no lymphadenopathy or organomegaly on examination. In these cases, careful examination of a peripheral blood film is sufficient but in the presence of any abnormal or suspicious features, a bone marrow examination should be performed to exclude leukaemia. The bone marrow in ITP shows increased numbers of normal megakaryocytes (as shown in Chapter 15, Fig. 15.11). Although the disease is immune mediated, platelet associated antibodies show high false positive and negative results and are therefore, not useful in making or excluding the diagnosis.

Platelets may also be consumed in the periphery, and a low platelet count almost always accompanies established disseminated intravascular coagulation (Table 28.6). Giant haemangiomas (Kasabach–Merritt syndrome) or an enlarged spleen may also sequester and destroy platelets.

Lack of marrow production of platelets often accompanies marrow infiltration by diseases, such as leukaemia. Other bone marrow failure syndromes, such as Fanconi's anaemia can also present initially with low platelets.

It is also possible to have a platelet function disorder. The commonest of these are Glanzmann's thrombasthenia, usually associated with a normal platelet count, and Bernard-Soulier syndrome, associated with a moderate to severe thrombocytopenia. Both are due to different platelet glycoprotein defects, and can be diagnosed by platelet function testing and flow cytometry.

In neonates, causes of thrombocytopenia vary depending on the gestation and clinical condition of the baby. In well term neonates, alloimmune thrombocytopenia, due to the transplacental passage of maternal anti-platelet antibodies directed against foreign paternal antigens on the babies platelets (akin to the red cell disorder Rhesus haemolytic disease of the newborn), needs to be excluded. In preterm neonates, benign gestational thrombocytopenia may be seen soon after birth but later appearance of thrombocytopenia often heralds sepsis.

## COAGULATION TESTING IN INFANTS AND CHILDREN

Interpreting the results of coagulation screening requires some basic knowledge of the coagulation cascade. Coagulation tests are performed in the laboratory (*in vitro*), and do not faithfully replicate the circumstances seen in the body (*in vivo*). The interpretation of laboratory tests often places a lot of emphasis on extrinsic and intrinsic pathways but these sequences of activation probably do not play a major role in

**Table 28.6:** Haematological finding in disseminated intravascular coagulation

1. Prolonged APTT
2. Prolonged PT
3. Prolonged thrombin time
4. Low fibrinogen
5. Low platelet count
6. Raised fibrin degradation products or D-Dimers
7. Red cell fragmentation on the blood film

the initiation of clotting *in vivo*. Despite this, the concept of extrinsic and intrinsic pathways is useful to be aware of when faced with an abnormal coagulation screen, and is shown in Chapter 15, Figure 15.12.

It is now thought that the key initiating event *in vivo* is exposure of tissue factor in response to endothelial damage. Tissue factor activates factor VII to form a complex, TF-VIIa, which cleaves factor X to its active form Xa. Xa can convert prothrombin to thrombin with low efficiency but this generation of small amounts of thrombin then activates feedback loops to increase coagulation factor activation. Factor VIII (activated by thrombin) and factor IX (activated by TF-VIIa and factor XI) form a complex VIIIa-IXa known as tenase. Tenase generates activated factor X with great efficiency. Thrombin also activates factor V, and a Xa-Va complex is formed which cleaves prothrombin to form thrombin. Thrombin generation leads to conversion of fibrinogen to fibrin with subsequent crosslinking by factor XIII. This pathway is summarized in Figure 28.8.

### WHEN TO PERFORM A COAGULATION SCREEN

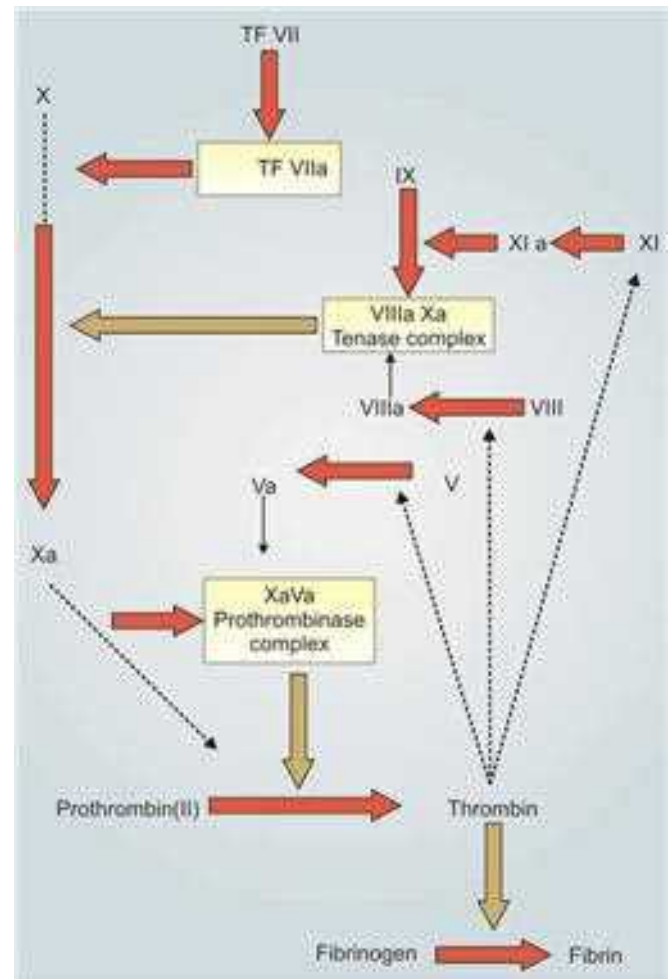
Coagulation screens should not be a routine blood test. They should be performed in any child with unusually severe or unexplained bleeding, or in very unwell children with suspected disseminated intravascular coagulation. They can also be performed prior to high-risk invasive interventions. A good bleeding history needs to be taken to determine the need for investigation, and to help guide appropriate tests. This includes a history of abnormal bleeding in the patient or relatives in response to haemostatic challenges, such as tooth extraction, cuts and minor operations, as well as a history of menorrhagia in older females. Some clinically significant bleeding disorders can have a normal coagulation screen (in particular, some von Willebrand's disease and Factor XIII deficiency; see Table 28.7), and some abnormal coagulation screens do not lead to a clinical risk of bleeding (e.g. Factor XII deficiency or lupus anticoagulant). Therefore, the results of testing always need to be interpreted in the light of a clinical history.

### Key Learning Point

- Do not rely on coagulation screening as the sole indicator of bleeding risk. History of bleeding in response to a haemostatic challenge is just as important.

### COAGULATION TESTS

When performing a clotting screen, care should be taken during venepuncture to avoid activation of clotting as this can produce artefactually low results. Samples should be from a free flowing vein; in particular, heel prick samples are unsuitable in neonates. Care should be taken to avoid contamination with heparin—a particular problem when sampling is from an indwelling venous catheter. Like the FBC, it is very important to be aware of normal ranges for the clotting screen especially in neonates who tend to have



**Fig. 28.8:** A revised coagulation cascade. Thick dashed arrows indicate low efficiency pathways. Thin dashed arrows indicate feedback activation loops. Boxes indicate complexes formed on phospholipid surfaces

**Table 28.7:** Bleeding disorders that may present with a normal coagulation screen and platelet count

- Factor XIII deficiency
- Glanzmann's thrombaesthesia/other platelet function disorders
- von Willebrand's disease
- Vascular disorders

significantly prolonged values compared to older children. In addition, values vary considerably between different automated analysers and may therefore, vary between hospitals; local normal ranges should always be used.

Initial screening tests should comprise of:

- *Prothrombin time (PT)*—this is a test of the overall activity of the extrinsic pathway. It measures the activity of factors II, V, VII and X, and is also dependent on adequate fibrinogen levels.
- *Activated partial thromboplastin time (APTT)*—this is a test for the overall activity of the intrinsic pathway and measures factors II, V, VIII, IX, X, XI and XII; it also requires adequate fibrinogen levels.
- *Thrombin time (TT)*—prolonged by quantitative and qualitative disorders of fibrinogen, the presence of inhibitory factors, such as fibrin/FDPs, and the presence of heparin.
- Fibrinogen level
- Platelet count.

Results of these tests along with clinical history can guide subsequent investigation. Bleeding times are generally unhelpful. A diagnostic algorithm is shown in Table 28.8.

The typical findings in disseminated intravascular coagulation are shown in Table 28.6; although coagulation screening is useful in this disorder, the primary therapy for DIC is treatment of the underlying cause. Replacement of coagulation factors with fresh frozen plasma or cryoprecipitate should be guided by the patient's clinical condition and presence of other risk factors for bleeding rather than treating the abnormal clotting screen *per se*.

## Factor Assays

Clinical aspects of inherited coagulation disorders are discussed in Chapter 15. Inherited factor deficiencies may initially be suspected on the coagulation screen, and confirmed by direct assay of the clotting factor. In the case of suspected von Willebrand's disease, von Willebrand Factor (vWF) should be measured both quantitatively (vWF antigen) and qualitatively (a functional test, such as a ristocetin cofactor assay). This is because low levels of vWF or normal levels of dysfunctional vWF can cause the disease. vWF can also rise with stress and therefore, repeated testing may be needed to exclude disease especially in young children who are difficult to venepuncture.

## Platelet Function Testing

Besides a platelet count and assessment of platelet morphology by light microscopy, it is possible to assess platelet function in a number of ways. Historically, a bleeding time has been used as a global test of platelet function but it is difficult to standardize, and not very predictive of bleeding risk. Currently, the three commonest techniques in use are platelet aggregation studies (looking at aggregation in response to various stimulants, such as epinephrine), flow cytometry (to assess expression of glycoproteins on the platelet surface), and use of a platelet function analyzer (PFA-100, an automated machine that measures the ability of platelets to form a plug under shear stress).

## Heparin

The presence of contaminating heparin in a sample is often initially suspected by the combination of a prolonged APTT with a significantly prolonged thrombin time (this test is exquisitely sensitive to heparin). A number of methods exist to try and confirm whether the abnormal result is due to heparin or not. These include a reptilase time (which measures the same pathway as the TT, but is unaffected by heparin), or methods to neutralize the heparin using protamine sulphate.

**Table 28.8:** Causes of abnormal coagulation tests

APTT	PT	TT	Fibrinogen	Platelets	Possible diagnosis
Prolonged	Normal	Normal	Normal	Normal	Factor VIII, IX, XI deficiency (Haemophilia A, B or C) von Willebrand's disease Lupus Anticoagulant Factor XII/ Contact factor deficiency
Prolonged	Prolonged	Prolonged	Normal or low	Normal or low	Heparin Liver disease Fibrinogen deficiency Vitamin K deficiency DIC
Prolonged	Prolonged	Normal	Normal	Normal	Vitamin K deficiency Warfarin Factor II, V, VII, X deficiency
Normal	Prolonged	Normal	Normal	Normal	Warfarin therapy Factor VII deficiency

## MONITORING OF ANTICOAGULANT THERAPY

Therapeutic anticoagulation in children is used to prevent or treat thrombosis. Heparin and warfarin are the two main agents in use. Heparin comes in two main formulations—standard unfractionated heparin and low-molecular weight heparin. The former is monitored by the APTT with a

therapeutic range of 1.5–2.5 times normal control values. Low molecular weight heparin therapy does not prolong the APTT, and needs to be monitored by anti-Xa levels. Warfarin therapy prolongs the PT but in order to standardize results between laboratories, this level is converted into an international normalized ratio (INR); the target INR varies depending on the indication for anticoagulation.

# Biochemical and Microbiological Investigations in Paediatrics

# 29

## INTRODUCTION

Most laboratory work is undertaken in laboratories whose principal workload is adult patients. There are specific issues, which can arise when the unwary consider children as small adults, e.g. inappropriate reference ranges and how the age of the child may change the nature of the sample submitted. This chapter aims to simply review key issues present in each of the core laboratory disciplines.

With the increasing range of laboratory tests, it is now estimated by the Royal College of Pathologists (UK) that 70% of all diagnoses depend upon laboratory results.

Before undertaking a clinical investigation, the clinician must consider two questions:

1. Will the chosen test confirm (or refute) a clinical suspicion, affecting alteration of management of the patient to obtain a clinical benefit (or avoid a problem), e.g. why identify hypercholesterolaemia in patients over 85? and
2. If the natural evolution of the condition is trivial or self-limiting, what additional information is obtained, e.g. stool culture in acute diarrhoeal illness.

This concept is best summarised in the quote:

"Before ordering a test, decide what you will do if it is either positive or negative and if both answers are the same and then don't do the test!"

## WHAT ARE THE ROLES OF DIAGNOSTIC TESTS?

There are only four specific reasons for doing a test. These are as follows:

### Screening

To take a population and pick out those with a disease with few false positive diagnosis. In certain circumstances, we

demand 100% sensitivity, i.e. all cases will be diagnosed, allowing a few false positives through and using a more specific confirmatory assay, e.g. neonatal thyroid stimulating hormone (TSH) screening using a cut off 30 mU/L on day 6 will identify all congenital hypothyroid cases and a number whose thyroid axis matures over first few weeks. This is necessary to avoid any missed cases.

Down's screening in pregnancy uses markers and maternal age to identify women at high enough risk (1 in 220) to justify amniocentesis with its concomitant 1% pregnancy loss. It fails to identify approximately a third of cases.

### Diagnosis

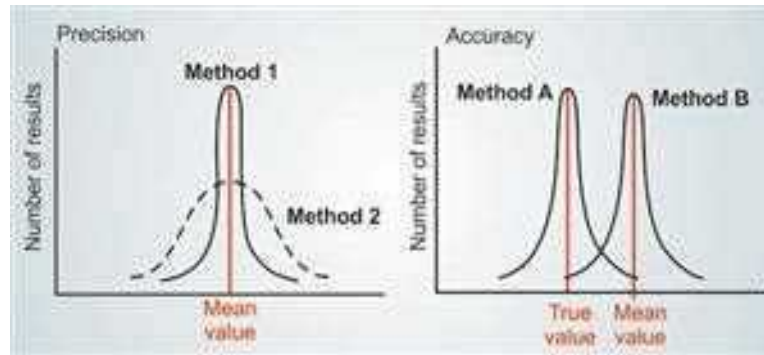
While some tests can specifically identify the illness (e.g. abnormal blood film in leukaemia), others may be less specific, e.g. aspartate amino transferase (AST) commonly used as a marker of liver disease is raised in muscle disease thus all 1–3 years old with a raised AST need a creatine kinase (CK) done concomitantly to exclude Duchenne's muscular dystrophy.

### Prognosis

This allows estimates of the likely outcome. For example, creatinine in renal impairment can act as a marker of degree of renal damage in an individual, or levels of  $\alpha$ -fetoprotein (AFP)/HCG are inversely proportional to outcome in non-seminomatous testicular tumours.

### Detection of Complications/Monitoring

With increasing laboratory use there is routine monitoring such as looking for side-effects from drugs. Identifying those with marrow suppression on immunosuppressants, e.g. azathioprine.



**Fig. 29.1:** Shows that precision is a measure of reproducibility with method 1 being more precise than method 2. From the second figure, both methods A and B are equally precise but method A is more accurate

## WHAT FACTORS ARE IMPORTANT IN INTERPRETING DATA?

### Quality of Information

The laboratory's role is to maximise accuracy and precision of a result (Accuracy is an indication of how close to the correct value; while precision is how reproducible a result is). To achieve this, laboratories carefully control as many factors as they can. They run quality controls, both internal (allowing regular precision) and intermittent external (to confirm accuracy) (Fig. 29.1).

The expansion of external quality control into rarer analytes has allowed laboratories to improve, particularly, inborn errors of metabolism investigations.

### Factors Occurring Before the Laboratory

Samples must always be collected under appropriate conditions. If the analyte is unstable, then appropriate preservative or rapid handling is required, e.g. fluoride oxalate tubes for glucose. They must be properly identified especially with multiple births.

More specific factors which can affect the result is to consider the biological diurnal variation in an analyte such as cortisol being higher in morning and lower in evening or over longer periods, such as gonadotrophin changes post puberty over a month in a female. Without considering the clinical features, interpretation is impossible.

A major effect on many analytes is the acute phase response to any illness. This physiological process identified by simple measures such as elevated C-reactive protein (CRP) is associated with widespread changes. There is vascular leakage of albumin into the extravascular space evident by reduced albumin levels and many micronutrient

measurements, such as iron and zinc fall rapidly as the body sequesters them to prevent them being available to bacteria. Prolonged inflammatory responses result in altered endocrine disturbances with, e.g. suppression of thyroid function (Sick Euthyroid syndrome).

Before being able to interpret a result, we need to be able to compare it to the normal homeostatic levels.

## WHAT IS NORMAL?

"Normal" is a term that is often used to include only "healthy" individuals. The term "normal range" encompasses a range from two standard deviations more and less than the median in a "healthy" population. This assumes the population data is Gaussian distributed (or mathematically transformed into Gaussian distributed) and encompasses 95% of these individuals.

Interpretation of laboratory data is then made against this healthy group of individuals. But they must be comparable if affected by sex, age, etc. But 2.5% lie above or below that range and are still healthy. The further they lie from the mean the more likely they are to be ill.

The second problem is best illustrated by cholesterol (Fig. 29.2). The normal UK range is 3.5–6.7 mmol/L. However, the risk of coronary heart disease increases progressively above 5.2 mmol/L doubling by 6.7 mmol/L. However, below 5.2 mmol/L the curve is not flat and there remains a shallow gradient of risk. Thus the idea of "normal" range may be less helpful. It follows that if 5% of normal results are outside the "normal" range, the chance of a healthy individual having one abnormal result is  $(1-0.95)^n$  where  $n$  is number of tests performed. When twenty tests are done, two-thirds will have one or more results out with the "normal range". In healthy individuals, chasing perceived abnormalities may not result in any clinical benefit.



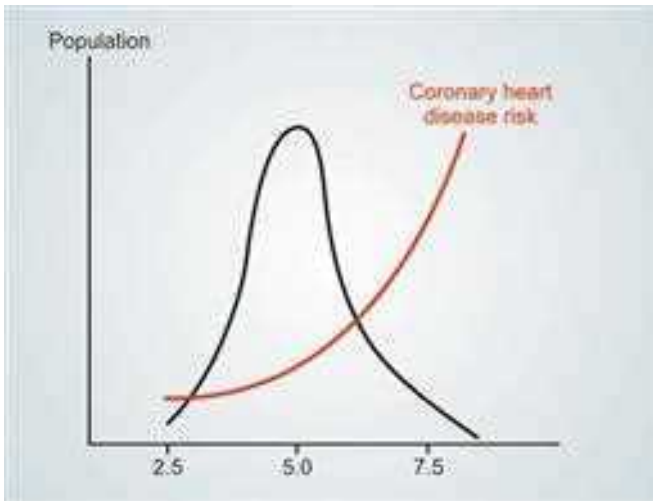


Fig. 29.2: Serum cholesterol concentration (mmol/L)

## WHAT DO YOU NEED TO KNOW ABOUT BIOCHEMICAL TESTS?

### Analytical

Major analytical advances occurred during the 70's from manual testing to automated analysers for common tests. The resulting reduction in sample volume requirements allowed biochemistry to support neonatal care.

Problems still remain, particularly in premature neonates where blood volume is more critical. Specific issues which can occur are excessive evaporation from small samples; concentrating the sample; problems if inadequate volume added to tubes containing liquid anticoagulant where there may be a direct dilution effect. With small sample volumes, it is important to discuss ones priorities with the lab to maximise the number of tests which will impact on that child/neonates care.

### The Assay Detection Limits

In paediatrics, different normal ranges are expected physiologically. A child with Thelarche will have an oestrogen level less than 100 pmol/L. The normal adult post-pubertal range being 150–1,000 pmol/L (depending upon day of cycle). Truly pre-pubertal children are less than 12 pmol/L. Most routine assay therefore fails to help in the clinical management of children, but highly sensitive radioimmunoassay (RIA) with detection limit of less than 10 pmol/L do offer advantages.

### Specific Sample Timing

An understanding of analyte stability and diurnal variation is required. Consideration of specific issues, such as only

measuring drugs, after adequate pharmacokinetic distribution has occurred, e.g. digoxin remains elevated till 6 hours post-dose, should be addressed prior to sample collection.

### Critical Difference Between Two Results

Particularly as more monitoring occur, it becomes important to be truly certain that a result has statistically changed. For this, the result must vary by 2.8 times the total variance [i.e.  $(SD \text{ Biological})^2 + (SD \text{ Analytical})^2$ ] where biological differences are the physiological variability in an analyte during the day and analytical refers to the imprecision in measurement (Table 29.1).

With increasing automation of analyses, the analytical imprecision has decreased. At present, typical critical differences for routine analytes are given at mid-point of adult reference range.

### Neonatal Reference Ranges

With modern ethical considerations, collecting blood to perform reference ranges in children is not possible. In premature neonates, one could even question if this is a pathophysiological state, so that there are no "healthy" comparable controls.

The ongoing maturation processes will affect the interpretation of results such as the progressive rise in glomerular filtration rate (GFR). Other physiological processes must be remembered such as the normal testosterone rise following birth in male infants, which disappears by 4 months of age.

Unfortunately most laboratories offer "adult reference ranges". The tables (Appendix A) demonstrate where this can cause particular issues in children. For simplicity, exact data for specific age ranges are not given. When interpreting an analyte, the pathophysiological process needs to be considered; particularly inflammation and the acute phase response such that some analytes increase, e.g.  $\alpha$ -1-antitrypsin and others decrease, e.g. zinc.

Table 29.1: Clinical difference between two results

Analyte	Biological variance (%)	Level (mmol/L)	Critical difference
Na	0.7	140	5
K+	5.1	4.2	0.6
Urea	13.6	5	1.9
Creatinine	4.6	60	14
Calcium	1.7	2.4	0.21
Phosphate	5.1	1.2	0.3
Alkaline phosphatase (IU/L)	6.7	60	20
Albumin (g/L)	3.1	40	4

## WHAT DO YOU NEED TO KNOW ABOUT MICROBIOLOGY TESTS?

### Urine

There are three major aspects to the microbiological analysis of urine:

1. Microscopy, culture and dipstick testing for leucocyte esterase
2. A surrogate for the presence of white cells and
3. Nitrite, a bacterial product

Urine can be collected from children at a variety of ages and in a number of ways. The age of the child and the method of collection and storage may affect the interpretation of the result.

### Methods of Urine Collection

#### Types of Sample

- Suprapubic aspirate (SPA): Urine is collected directly via a needle inserted through the skin into the bladder
- Clean-catch-urine
- Mid-stream specimen of urine
- Bag specimen of urine
- Catheter specimen of urine.

### Microscopy of Urine

Microscopy is performed to identify formed elements present within the urine; these include white cells (pyuria), red blood cells (RBC) (haematuria) bacteria and casts.

#### Pyuria

The excretion of 400,000 leucocytes/hour, which corresponds to more than 10 white cells  $\text{mm}^5$  correlates with the presence of urinary tract infection (UTI). However, pyuria in the absence of bacteriuria is not a reliable guide to infection as leucocytes can be found in all types of inflammation and in older females pus cells may come from the vagina. The amount of pyuria also varies with urine flow and pH.

#### Bacteriuria

The presence of organisms in unspun urine is highly suggestive of significant bacteriuria. Bacteriuria is demonstrable in unspun urine in over 90% of cases with  $10^5$  bacteria/ml or higher is present. However, a negative result does not rule out infection and has poor sensitivity at lower colony counts.

### Dipstick Testing

Dipstick testing can be performed for a number of analytes. In UTI the most useful are leucocyte esterase and nitrite.

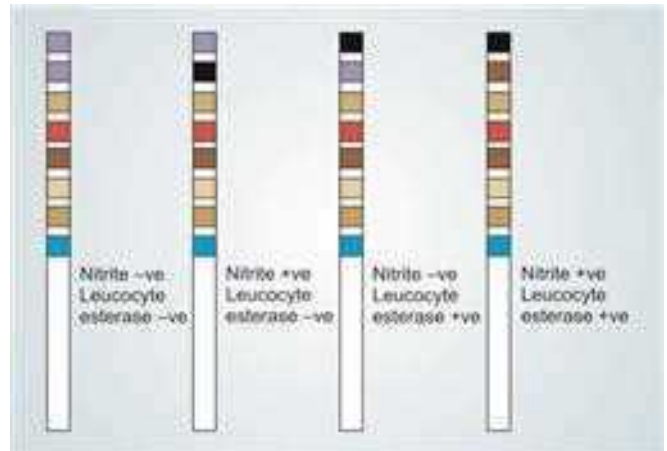


Fig. 29.3: Dipstick testing

Overall dipstick testing is less reliable in children under 2 years of age, in children over two if both leucocyte esterase and nitrite are positive it is suggestive of the presence of a UTI, if both leucocyte esterase and nitrite are negative it is useful to rule out a diagnosis of UTI (Fig. 29.3).

### Culture of Urine

Most urinary tract infections (UTI) are due to a single organism. Common organisms causing UTI in children include; *Escherichia coli*, which probably causes 75% or more of cases. *Klebsiella spp*, *Proteus spp* and *Staphylococcus saprophyticus*. Less common causative organisms include *Enterobacter spp*, *Citrobacter spp*, *Serratia marcescens*, *Acinetobacter species*, *Pseudomonas spp* and *Staphylococcus aureus*. The number of bacteria taken as significant bacteriuria varies depending upon the type of sample;

- Suprapubic aspiration of the bladder; significant culture if more than  $10^2$  colony-forming units per millilitre (CFU/ml)
- In-out catheterization of the bladder; significant culture if more than  $10^3$  CFU/ml
- Clean-voided urine; significant culture if more than  $10^4$  CFU/ml
- Carefully collected bag, nappy or pad specimen; significant culture if more than  $10^5$  CFU/ml

A false positive result due to contamination should be suspected when:

- Bacteria, but no leucocytes (except in immunocompromised patients)
- Multiple organisms cultured
- Blood and the specimen is from a menstruating girl
- Prolonged storage more than 8 hours at room temperature

A false negative result may be due to:

- Inadequate filling of a specimen bottle containing boric acid (the preservative is bactericidal at high concentrations)
- Antibiotics excreted in the urine
- Prolonged storage, i.e. more than 48 hours at fridge temperature.

### Cerebrospinal Fluid

Cerebrospinal fluid is examined microscopically then cultured. Examination for bacterial antigens and polymerase chain reaction (PCR) may also be performed. Meningitis can occur in children with normal CSF microscopy. If it is clinically indicated, children who have a "normal" CSF should still be treated with IV antibiotics pending cultures.

### Microscopy

Cerebrospinal fluid white cell count is higher at birth than in later infancy and falls fairly rapidly in the first 2 weeks of life. In the first week, 90% of normal neonates have a white cell count less than 18.

The presence of any neutrophils in the CSF is unusual in normal children and should raise concern about bacterial meningitis. Neither a normal Gram stain nor a lymphocytosis excludes bacterial meningitis; in fact a Gram stain may be negative in up to 60% of cases of bacterial meningitis even without prior antibiotics.

Cerebrospinal fluid findings in bacterial meningitis may mimic those found in viral meningitis particularly early on and neutrophils may predominate in viral meningitis even after the first 24 hours. Antibiotics are unlikely to significantly affect the CSF cell count in samples taken less than 24 hours after antibiotics (Table 29.2).

**Table 29.2:** Interpretation of CSF findings

	White cell count		Biochemistry	
	Neutrophils ( $\times 10^6/L$ )	Lymphocytes ( $\times 10^6/L$ )	Protein (g/L)	Glucose (CSF: blood ratio)
Normal ( $>1$ month of age)	0	$\leq 5$	$< 0.4$	$\geq 0.6$ (or 2.5 mmol/L)
Normal term neonate	0	$\leq 11$	$< 1.0$	$\geq 0.6$ (or $\geq$ 2.1 mmol/L)
Bacterial meningitis (but may be normal)	100-10,000	Usually $< 100$	$> 1.0$ (but may be normal)	$< 0.4$ (but may be normal)
Viral meningitis	Usually $< 100$	10-1000 (but may be normal)	0.4-1 (but may be normal)	Usually normal

### Traumatic Tap

In traumatic taps one can allow one white blood cell (WBC) for every 500–700 RBC however this is not entirely reliable and in order not to miss any patients with meningitis the safest way to interpret a traumatic tap is to count the total number of white cells and disregard the red cell count. If there are more white cells than the normal range for age, then the patient should be treated.

### Polymerase Chain Reaction

Polymerase chain reaction (PCR) is routinely available for *Neisseria meningitidis*, herpes simplex and enterovirus, but results are not usually available in a timescale, which informs immediate management decisions. Meningococcal PCR is particularly useful in patients with a clinical picture consistent with meningococcal meningitis, but who have received prior antibiotics. Enterovirus PCR should be requested on CSF from patients with clinical and/or CSF features of viral meningitis. HSV PCR should be requested for patients with clinical features of encephalitis.

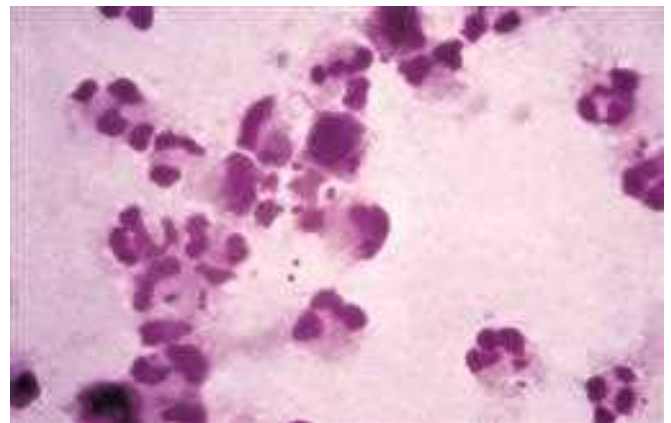
### Bacterial Antigens

Cerebrospinal fluid bacterial antigen tests have low sensitivity and specificity and have little role if any in management.

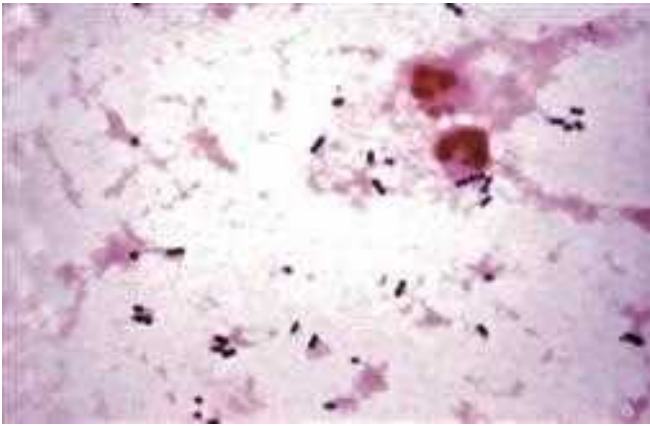
### Culture

The usual organisms causing bacterial meningitis in children over 2 months of age are *Neisseria meningitidis* and *Streptococcus pneumoniae*. *Haemophilus influenzae* type b (HiB) is much less common since the onset of vaccination for HiB.

In infants less than 2 months of age Group B Streptococcus, *E. coli* and other gram-negative organisms and *Listeria monocytogenes* should also be considered (Figs 29.4 and 29.5).



**Fig. 29.4:** Cerebrospinal fluid with pus cells and *Neisseria meningitidis*



**Fig. 29.5:** Cerebrospinal fluid with pus cells and *Streptococcus pneumoniae*

### Blood Samples

Most blood tests performed in microbiology measure the immune response to infection and the normal ranges are broadly the same as in adults. The major exception to this is streptococcal serology. Infection with group A *Streptococcus* results in the production of specific antibodies against streptococcal exoenzymes, the most important of which are anti-streptolysin O (ASO) and anti-deoxyribonuclease-B (ADB).

The ASO response is generally good in pharyngitis and tonsillitis but will not distinguish between infections with groups A, C and G streptococci, the response is generally poor in impetigo and pyoderma.

The mean ASO normal levels are age dependant:

Pre-school—less than 1:200 u/ml

School age—less than 1:320 u/ml

Adult—less than 1:200 u/ml

The ADB response is good in skin as well as throat infections and may be more specific for group A streptococci (GAS) infection. The ADB test shows elevated titres in more than 90% of clinically diagnosed cases of pyoderma, acute glomerulonephritis and acute rheumatic fever. ADB titres peak later than ASO levels and remain elevated for several months. The ADB can, therefore, be of value if there is a delay in diagnosis.

The mean normal ADB levels are age dependant:

Pre-school—1:60

School age—1:170

Adult—1:85

### Examination of Faeces

Pathogens found in the stools of children are broadly the same as those found in adults. However, the age of acquisition of such pathogens varies between developed and developing countries. In developing countries, *Campylobacter*, e.g. is

**Table 29.3:** Age of acquisition of *Campylobacter* in different countries

Countries (ref.)	Age of infection (months)
Nigeria	24
Tanzania	18
China	12–24
Thailand	< 12 (18.8%) 12–23 (12.3%) 24–59 (10.3%)
Bangladesh	<=12 (38.8%) > 12 (15.9%)
Egypt	0–5 (8%) 6–11 (14%) 12–23 (4%)

[Adapted from Emerg Infect Dis 8(3), 2002.]

the most commonly isolated bacterial pathogen from children less than 2 years old with diarrhoea. The disease does not appear to be important in adults.

In contrast in developed countries infection may occur in adults and children. Poor hygiene and sanitation and the close proximity to animals may all contribute to easy and frequent acquisition of any enteric pathogen. The age of acquisition of *Campylobacter* in a number of countries is illustrated below (Table 29.3).

Thus, the spectrum of pathogens sought in the microbiology laboratory for children of different ages will need to be determined by the knowledge of local epidemiology.

### Antibiotic Monitoring and Interpretation

#### Antibiotic Monitoring

It is necessary to monitor the levels of antibiotic for two major reasons. Some antibiotics have a narrow therapeutic range that is the ratio between therapeutic levels and toxic levels is so antibiotic levels are measured to reduce the potential for toxicity. For other antibiotics it may not always be possible to predict serum levels, in this case antibiotic levels are monitored to ensure efficacy. The antibiotics whose levels are most commonly measured are the aminoglycosides (gentamicin, tobramycin and amikacin) and the glycopeptide antibiotic vancomycin.

#### Aminoglycoside Dosing and Monitoring

Gentamicin should preferably be given as an intermittent IV Infusion with the antibiotic diluted with a maximum of 100 ml compatible infusion fluid and administered over 30 minutes. The undiluted solution may however be given as a slow IV Bolus injection administered over 3–5 minutes.

The dosage varies with the age of the child and the indication for gentamicin therapy. For most indications a

single daily dose regimen should be employed as it ensures effective peak levels and minimises side-effects. In this case the dose should be:

Neonate (< 32 weeks): 4–5 mg/kg every 36 hours

Neonate (> 32 weeks): 4–5 mg/kg every 24 hours

Child 1 month–18 years: 7 mg/kg every 24 hours

However, a single daily dose regimen is not appropriate for all patients and those with endocarditis, meningitis and cystic fibrosis should be managed with a multiple daily dose regimen. For endocarditis and meningitis the dose is as below:

Neonate (< 29 weeks): 2.5 mg/kg every 24 hours

Neonate (29–35 weeks): 2.5 mg/kg every 18 hours

Neonate (> 35 weeks): 2.5 mg/kg every 12 hours

Child 1 month–12 years: 2.5 mg/kg every 8 hours

Child 12–18 years: 2 mg/kg every 8 hours

For cystic fibrosis patients with Pseudomonas lung infection the dose should be:

1 month–18 years: 3 mg/kg every 8 hours

In patients with impaired renal function, the daily dose may need to be reduced and/or the intervals between doses increased to avoid accumulation of the drug.

### Gentamicin Monitoring Single Daily Dose Regimen

Plasma concentrations and renal function should be monitored to ensure efficacy and prevent toxicity. Frequency should be adjusted according to the results obtained.

Measure the first trough concentration immediately before the second dose and peak concentration (if required) 1 hour after second dose.

Neonates: Peak concentration (1 hour post-dose) should measure 8–12 mg/L and trough concentration (pre-dose) should measure less than 2mg/L.

Child 1 month–18 years: Trough concentration (pre-dose) should measure less than 1 mg/L. Peak concentrations are less critical with this dose regimen in this age group.

### Multiple Daily Dose Regimens

The first peak concentration should be taken 1 hour after third dose. Measure first trough concentration should be immediately before the fourth doses.

All age groups; peak concentration (1 hour post dose) should measure 8–12 mg/L and trough concentration (pre-dose) should measure less than 2 mg/L.

### Endocarditis

In endocarditis due to *Streptococcus viridans* gentamicin is used for its synergistic effects with penicillin and as such lower concentrations are acceptable.

The first peak concentration should be measure in 1 hour after third dose. The first trough concentration should be taken immediately before the fourth dose.

Peak concentration (1 hour post-dose) should measure 3–5 mg/L and trough concentration (pre-dose should measure less than 1 mg/L).

If there is no change in dosage regimen or renal function, repeat trough levels every 3 days.

### Vancomycin Therapy

Vancomycin is a glycopeptide antibiotic, which is active against gram-positive organisms. Critically ill children require higher doses of vancomycin to achieve therapeutic levels.

Trough levels should be taken any time after 2 hours before the next dose is due prior to the third dose.

The target trough level is 8–15 mg/L, however, the microbiologist may request higher levels in some infections. Peak levels do not need to be checked routinely.

If trough levels are within accepted range and there is no change in renal function no further monitoring is required.

- If trough levels are low (< 8 mg/L), increase the dosage interval to 6 hourly
- If trough levels are high (> 15 mg/L), reduce dosing interval to 12 hourly
- Re-check levels.

If renal function deteriorates (increase in creatinine more than 50% from baseline or 50% drop in urine output) during the course of vancomycin therapy recheck trough level as soon as possible. Adjust doses only if necessary, following the guidance above.

# Paediatric Emergencies

## INTRODUCTION

Paediatric patients who present to the emergency department pose extraordinary challenges to healthcare personnel. Faced with such a patient the situation can at first appear frightening and overwhelming. The purpose of this chapter is to give a brief account of common emergencies seen in the paediatric population and in the process provide a simplified, structured approach to the management of these children that can be applied to any situation. In the process outcomes for these patients can be improved and a stressful situation can be transformed into ultimately one of the most satisfying areas of paediatric medicine.

## DIFFERENCES BETWEEN ADULTS AND CHILDREN IN THE EMERGENCY DEPARTMENT

Children are not small adults. They demonstrate important differences in their size, anatomy, physiology and psychology that impact on management in the emergency setting.

### Size

Children are obviously smaller than adults and their weight changes as they become older. This is important as almost all drug and fluid calculations in paediatrics are calculated on a per weight basis. It is, therefore, essential to have a relatively accurate weight for any child presenting to the emergency department. Occasionally a parent or guardian may know the child's weight but this tends to be the exception. The most accurate means to assess the child's weight is to simply weight the child (either on their own or whilst being held by a parent) however, this is often impractical in the emergency setting. Other methods are, therefore, required.

The Broselow tape is a tape measure that is laid alongside the child and gives an estimate of the child's weight based on their height. It is easy to use, relatively accurate and requires minimal training in its use.

An alternative, if the child's age is known, is to use the following formula:

$$\text{Weight (in kg)} = (\text{Age} + 4) \times 2$$

This formula is relatively accurate for children between the ages of 1 year and 10 years and has the advantage that it can be used to plan drug and fluid doses before the child's arrival. For children less than 1 year, in general the birth weight becomes double at 6 months and triple at 12 months of age. If birth weight is not known, full term neonate can be considered to weigh 3–4 kg and 12-month-old infant as 10 kg.

## Anatomy and Physiology

Children have important differences in their anatomy and physiology to adults that impact on their emergency care.

### *Airway and Breathing*

Young children have relatively larger heads and shorter necks than adults and this can result in relative neck flexion. The face, mouth and jaw are small and the tongue large. The trachea is short and easily compressible. In combination this can result in an increased risk of airway obstruction and means that great care must be taken during airway positioning manoeuvres. In addition, children's lower airways are also small resulting in a greater propensity to obstruction even to relatively minor stimuli such as viral infections. Additionally, infants rely mainly on diaphragmatic breathing that tends to fatigue more easily than adults. Children's lungs are smaller and their respiratory rates faster—a respiratory rate of 40/min may be normal in an infant but signify severe respiratory distress in a 12 year old.

### *Circulation*

Infants have a relatively small, fixed stroke volume that relies on a tachycardic response to increase cardiac output. This means they tolerate bradycardia poorly. Stroke volume

**Table 30.1:** Normal range of respiratory rate, heart rate and blood pressure according to ages

Age in years	Respiratory rate	Heart/Pulse rate	Systolic BP
<1	30–40	110–160	70–90
1–2	25–35	100–150	80–95
2–5	25–30	95–140	80–100
5–12	20–25	80–120	90–110
>12	15–20	60–100	100–120

increases with age as the heart enlarges. This results in babies and young children having faster resting heart rates than older children and adults. It is, therefore, important to have an appreciation of the normal range of age specific heart rates (Table 30.1). A heart rate of 60/min in an adult can be normal, in an infant it is considered as a cardiac arrest. Young children have a relatively higher circulating blood volume per bodyweight (newborn 85 ml/kg, 1 year old 80 ml/kg, 10 year old 75 ml/kg) than adults (70 ml/kg) but the actual total blood volume is small. The young child does, therefore, not tolerate blood loss well, even when the amount appears to be relatively small. Similarly, even relatively small amounts of fluid loss, such as diarrhoea, can result in significant dehydration.

### Psychology

Children are often very frightened in the emergency department. The appearance of a large number of adults they do not know, no matter how well-intentioned, can at times be overwhelming and make the assessment of a child difficult. Young children are often non-verbal and find it difficult to express their emotions. In these settings the presence of tachycardia and tachypnoea can be difficult to distinguish between pathology and emotional distress. It is important, therefore, to attempt to minimise the distress caused to the child. The child should always be accompanied by their parents except in the most exceptional circumstances. The number of staff around the child and the background noise should be kept to a safe minimum whenever possible and a caring, gentle approach taken at all times.

### BASIC STRUCTURED APPROACH TO MANAGEMENT

A structured approach to any seriously ill patient allows appropriate early resuscitation and stabilisation to occur, even if the definitive diagnosis is complex or not known. It is highly reliant on adequate preparation and teamwork is essential. It is the approach recommended by resuscitation organisations such as the Advanced Life Support Group. Any emergency can be approached in this manner.

**‘Problem Recognition and Treatment have Higher Priority than Definite Diagnosis’.**

The structured approach relies on four basic principles:

1. *Preparation and teamwork:* It is of great benefit when a dedicated communication line from and to the Ambulance Service and the Emergency Medicine Department is available. Basic information can be gathered such as the patient’s age and current problems. This allows the team to develop a state of readiness. In particular two key areas can be prepared:
  - A. Calling for relevant help in advance, e.g. anaesthetic or intensive care support. Resuscitation is reliant on a team approach.  
*‘Blow the whistle first and assemble the players before starting the game’.*
  - B. Prepare appropriate equipment, drugs and fluids. In a resuscitation situation even simple calculations can prove challenging. Spending a few minutes before the arrival of the patient calculating the likely weight, drug doses, defibrillation charge, endotracheal tube size, etc. can prove extremely valuable and make any resuscitation run more smoothly.
2. *Recognise and treat immediate life-threatening situations (resuscitation):* This should be approached via a systematic Airway, Breathing, and Circulation (ABC) approach. Examples include obstructed airway requiring airway opening manoeuvres, apnoea or severely compromised breathing requiring oxygen or assisted ventilation, and circulatory collapse or cardiorespiratory arrest requiring fluid administration or CPR. At this stage recognition and management of the initial problem is more important than the underlying diagnosis.
3. *Identify key features that point to a likely working diagnosis so that early emergency treatment can be started:* For example, the presence of a rash and fever may point to the provisional diagnosis of sepsis and allow early use of appropriate antimicrobials. Recognition of a heart murmur in a collapsed infant may point to a diagnosis of a duct-dependent cardiac lesion and the initiation of a prostaglandin infusion. In both of these situations emergency treatments can be initiated before an absolute definitive diagnosis is arrived at.
4. *Stabilisation and transfer:* Once the patient has been resuscitated and emergency treatment has been started the next aim is to optimise the patient’s condition. This involves a thorough reassessment of the patient’s physiology and response to resuscitation, repeating the ABC approach, and may involve additional treatment. Examples include optimising electrolytes in a patient post-cardiac arrest or splinting a femoral fracture in a patient post-trauma. Arrangements can then be made for the safe transfer of the patient to an area where definitive treatment can be offered or ongoing resuscitation provided, e.g. operating theatre, ward or intensive care unit.

With practice this structured approach can be used quickly and effectively and allows a hierarchical approach to serious problems encountered rather than relying on establishing a definitive diagnosis before treatment is initiated. It can, therefore, be applied to any condition or situation and does not rely on specialist knowledge of at times complex conditions.

#### Key Learning Points

- ➔ Problem recognition is more important than establishing a definitive diagnosis.
- ➔ Always manage problems in an ABC approach. Life-threatening problems must be recognised and treated first.
- ➔ Be aware of age-specific normal ranges.
- ➔ Team work is essential in the emergency management of unwell children

## CARDIAC ARREST

The science underpinning guidelines on the management of cardiac arrest in children is constantly evolving. In response to this, new consensus guidelines have recently been published in 2010 by the European Resuscitation Council, the American Academy of Paediatrics, the American Heart Association and the International Liaison Committee on Resuscitation (ILCOR). References are provided at the end of the chapter for interested readers who wish to explore these guidelines in greater depth.<sup>1,2</sup> Drug doses are given in the algorithms and in Table 30.2. Full proficiency at these skills is best achieved by attending a course provided by organisations such as the Advanced Life Support Group, Resuscitation Council or

similar national resuscitation organisations within one's own country. In addition, hospitals and emergency departments can run their own in-house mock resuscitation-based scenarios where staff can practice their skills on resuscitation mannequins on a regular basis. The standard format as outlined by resuscitation manuals is documented below.<sup>3,4</sup>

### Mechanisms of Cardiac Arrest in Children

Children are usually healthy with excellent cardiac function, normal heart valves and patent coronary arteries that are not compromised by atherosclerosis. The mechanisms of cardiac arrest in children are, therefore, different from those of adults. In children cardiac arrest usually occurs secondary to either respiratory or circulatory failure (e.g. severe asthma, airway obstruction or septic shock) rather than a primary cardiac event such as arrhythmia due to myocardial infarction. This means that there may be a period pre-arrest in children that is amenable to intervention to prevent progression to cardiac arrest. It also means that when a cardiac arrest does occur the arresting rhythm is often asystole and the outcome is often poor. It is, therefore, important to realise the importance of recognition of the sick child to prevent cardiac arrest and the importance of following standard treatment algorithms when a cardiac arrest has occurred.

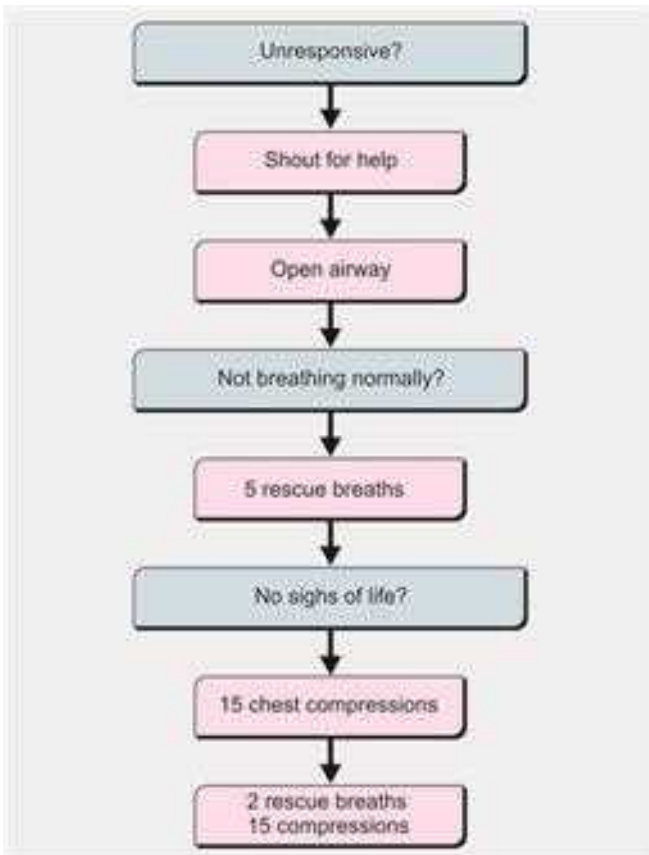
### Paediatric Basic Life Support

The algorithm for the management of paediatric basic life support is demonstrated in Figure 30.1. The sequence of actions is as follows:

**Table 30.2:** Emergency drugs and dosage

<i>Useful for resuscitation</i>		
Weight in kg = (Age in years + 4) × 2		
Initial fluid bolus for shock 20 ml/kg		
10% Dextrose (if Blood sugar < 3 mmol/L) 5ml/kg in 20 minutes		
Name	Dose	Route
Activated charcoal	1g/kg	Oral
Adrenaline—CPR	0.1 ml/kg of 1: 10,000	IV/IO/ETT
Adrenaline—anaphylaxis	0/0.1 ml/kg of 1:1,000	Deep IM
Adrenaline—croup	1–5 ml of 1:1,000	Nebulised
Aminophylline—acute asthma, anaphylaxis	5 mg/kg	Bolus IV Infusion over 20–30 minutes followed by continuous infusion 1mg/kg per hour
Cefotaxime	50 mg/kg every 6–8 hours	IV/IO
Dexamethasone—brain tumour	500 µg/kg	IV/oral
Diamorphine	0.1 mg/kg	Intranasal
Diazepam—status epilepticus	0.5 mg/kg	Rectal
Dopamine	1–10 µg/kg/min	Low cardiac output
Glucagon	500 µg if < 25 kg, 1 mg if >25 kg	IV/IO
Hydrocortisone	4 mg/kg (max 100 mg)	Severe asthma, shock
Insulin	0.1 unit/kg per hour	Infusion
Mannitol	20% 1.25–2.5 ml/kg	Infusion over 30 minutes
Morphine	100–200 µg/kg	IV/IO
Naloxone	10 µg/kg	IV/IO
Salbutamol	2.5–5 mg	Nebulised
Sodium bicarbonate	1–2 mmol/kg	Slow IV/IO





**Fig. 30.1:** Paediatric basic life support. (Copyright, European Resuscitation Council. Source: www.erc.edu, 2011/001, Reproduced with the kind permission of the Resuscitation Council, UK)

1. **SAFE approach:** Shout for help, Approach with care (ensure safety of rescuer and child), Free from danger (ensure no ongoing danger to child), Evaluate.
2. **Check for responsiveness:** Gently stimulate the child and ask loudly 'are you alright?'
3. **If child unresponsive:** Place child on back and carefully open airway using the following manoeuvres:
  - A. **Head tilt:** Gently tilt head backwards by placing rescuer's hand on patient's forehead.
  - B. **Chin lift:** Lift the chin by placing rescuer's fingers under bony part of chin and lifting. Be careful not to compress the soft tissues of the jaw or this may result in airway compression.
  - C. **Jaw thrust:** Push the jaw forward by placing fingers behind the angle of the jaw and pushing forward.
4. **Assess for normal breathing:** Place your face close to the child's face and look at the child's chest. Look for chest movement, listen for breath sounds coming from the mouth and nose, and feel for air movement on your cheek (Look, Listen and Feel).
5. **If child not breathing normally or if breathing is absent:**
  - A. Remove any obvious airway obstruction (e.g. foreign body) using a single finger sweep if an object can be seen but do not use a blind finger sweep as this may impact any hidden foreign body.
  - B. **Give 5 rescue breaths:** A rescue breath is a slow steady breath lasting 1–1.5 seconds that is designed to make the chest visibly rise. A rescue breath can be administered by mouth-to-mouth ventilation but is best achieved in hospital with a face mask and self-inflating bag and 100% oxygen. The mask should cover both mouth and nose. Ventilation using this mask/bag technique should be highly effective and it is important to note that resuscitation should not be delayed for endotracheal intubation if adequate chest movement is achieved using this technique.
6. **Assess circulation:** This should be done rapidly and take no more than 10 seconds.
  - A. Look for signs of life—coughing, gagging, and movement.
  - B. Check for pulse—brachial pulse in babies, carotid pulse for child (the femoral pulse can also be checked in infants and children). Assessing for pulses in babies and children can be very difficult, even to the most experienced clinicians. In the absence of signs of life if there is difficulty in feeling the pulse, or if there is any question as to whether it is present or not, then it should be assumed that the pulse is absent.
  - C. If the pulse is absent or less than 60 beats/minute then chest compressions should be commenced immediately and combined with rescue breathing. Fifteen compressions should be given before giving a further two rescue breaths. Chest compressions are achieved by compressing the lower half of the sternum in all age groups. The best landmark is one finger-breadth above the xiphisternum. This can be done using the heel of one or both hands in children, and by both thumbs using the encircling technique in infants.
  - D. **Emphasis must be placed on achieving adequate depth of compression:** at least one-third of the anterior-posterior chest diameter in all ages. After compressing the chest it is important to allow complete release (recoil) to allow adequate cardiac filling. The compression rate should be between 100/minute and 120/minute for all ages. Advice from the European Resuscitation Council is to 'push hard and fast'.<sup>1</sup>
7. **Ongoing resuscitation:** A compression ventilation ratio of 15:2 should be followed in all infants and children. If the rescuer is on their own a ratio of 30:2 can be used. Try to avoid any interruptions to ongoing CPR as this

may worsen outcome. Do not stop resuscitation unless there are definite signs of life or a definite strong pulse greater than 60 beats/min is detected.

### The Choking Child/Foreign Body in Airway

The algorithm for the management of the choking child is shown in Figure 30.2. Foreign body obstruction of the airway most commonly occurs in younger children when eating or playing with small toys. The onset of choking or stridor is usually very suddenly and the child is usually otherwise well with no prodrome. This distinguishes it from other causes of upper airway obstruction such as croup or epiglottitis in which the child usually has a prodromal illness. The treatment of airway obstruction due to other causes, e.g. croup or epiglottitis is different from that of foreign body obstruction.

The main feature of the algorithm is distinguishing between an effective and ineffective cough. The child who is alert and coughing effectively (loud cough, crying, fully responsive, able to take breaths) should be carefully observed until the foreign body is expelled or the child deteriorates. If the cough is ineffective (unable to vocalise, unable to breath, cyanosed, quiet or silent cough) then the child should be placed in a head down position over the rescuer's knee and back blows given (heel of one hand, blow directed between the scapulae). If the foreign body has not been expelled after five back blows then chest thrusts (same landmarks as for CPR) should be used in infants, and abdominal thrusts in children over 1 year old. Abdominal thrusts should not be used in infants due to the high risk of abdominal injury in this age group. If at any point the child loses consciousness then the rescuer should revert to the Basic Paediatric Life Support algorithm (Fig. 30.1).

### Advanced Management of Cardiopulmonary Arrest

The key difference between basic life support and advanced life support is the early assessment of underlying cardiac rhythm to identify whether defibrillation may be of benefit. Shockable rhythms are pulseless ventricular tachycardia (VT) and ventricular fibrillation (VF). They are most likely to occur in the context of a sudden, witnessed collapse and account for approximately 5–20% of paediatric cardiac arrests and are more likely the older the child. Non-shockable rhythms are pulseless electrical activity (PEA) [previously known as electromechanical dissociation (EMD)], bradycardia less than 60 beats/min and asystole. They account for the majority of paediatric cardiac arrests and are the usual arresting rhythm in cardiac arrest in children secondary to hypoxia of whatever cause. The algorithm for advanced paediatric life support is demonstrated in Figure 30.3 and a more detailed analysis of the management of shockable rhythms is shown in Figure 30.4. It is important to note that basic life support is initiated at the start of advanced resuscitation until monitoring has been established and the underlying rhythm analysed and as such it is important to emphasise that even advanced resuscitation practitioners should be fully competent in basic life support.

During cardiopulmonary resuscitation consideration should be given to possible reversible causes of cardiopulmonary arrest. These can be remembered by using the 4 Hs and 4 Ts approach:

<b>4 Hs</b>	<b>4 Ts</b>
Hypoxia	Tension Pneumothorax
Hypovolaemia	Toxins
Hyper/hypokalaemia	Tamponade (cardiac or pulmonary)
Hypothermia	Thrombosis (cardiac or pulmonary)

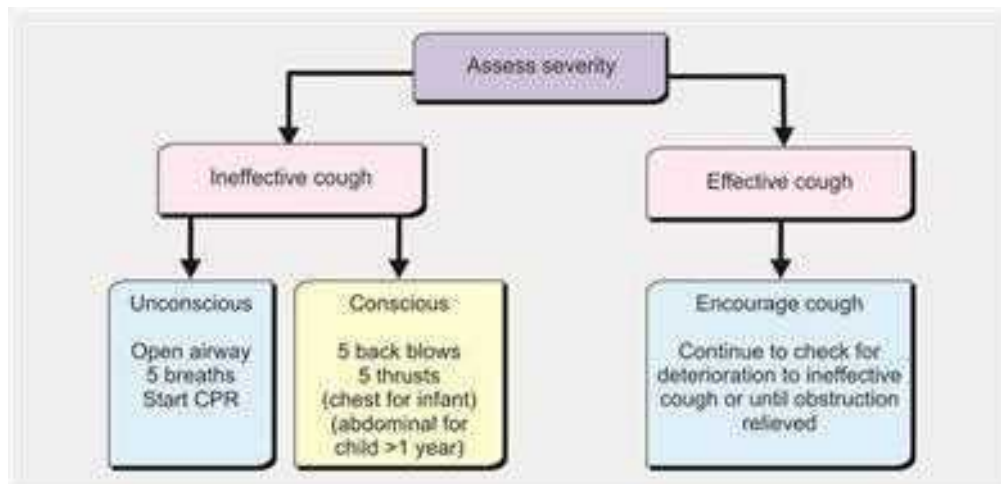


Fig. 30.2: Paediatric choking treatment algorithm. (Reproduced with the kind permission of the Resuscitation Council, UK)

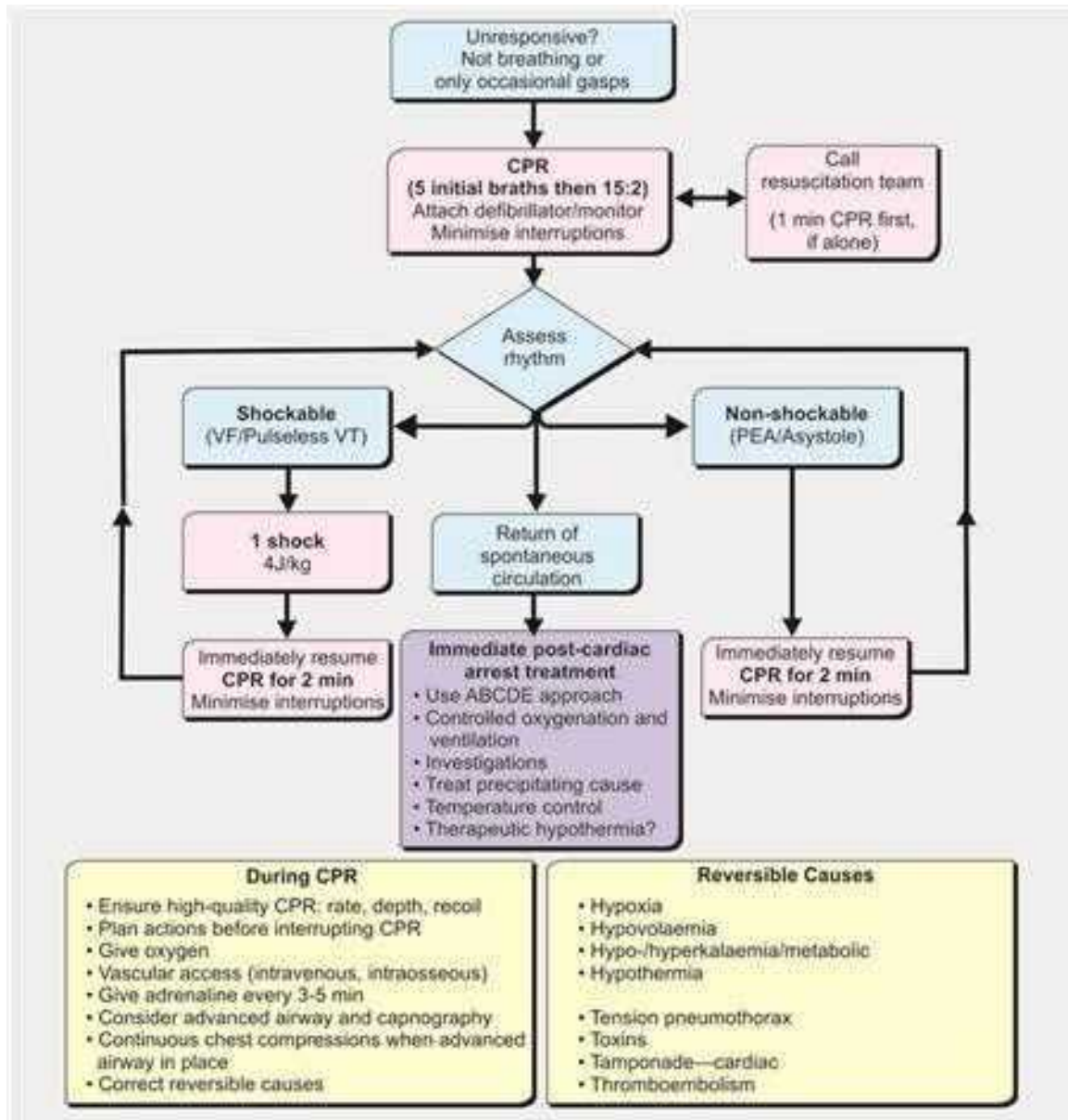


Fig. 30.3: Advanced paediatric life support (Copyright, European Resuscitation Council, www.erc.edu, 2011/001, Reproduced with the kind permission of the Resuscitation Council, UK)

The sequence of action in advanced paediatric life support is as follows:

1. Commence basic life support as above, providing a compression:ventilation ratio of 15:2.
2. *Establish cardiac monitoring and assess cardiac rhythm:* This should be done as soon as possible and can be done by the attachment of defibrillation pads that also assess rhythm.
3. Identify whether arrest rhythm is shockable (pulseless VT, VF) or non-shockable (pulseless electrical activity, bradycardia or asystole).
4. *Shockable rhythms:* The main determinant of outcome in cardiac arrest secondary to a shockable rhythm is the time to defibrillation. For every minute delay in defibrillation survival decreases. Defibrillation should, therefore, be attempted immediately upon identification. The defibrillation charge should be 4 J/kg for all shocks and the dose chosen should be rounded upwards in the event that the deliverable dose is not identical to that available on the defibrillator. Give one shock then immediately recommence CPR for 2 minutes before assessing rhythm on the cardiac monitor. If still in pulseless VT/VF then

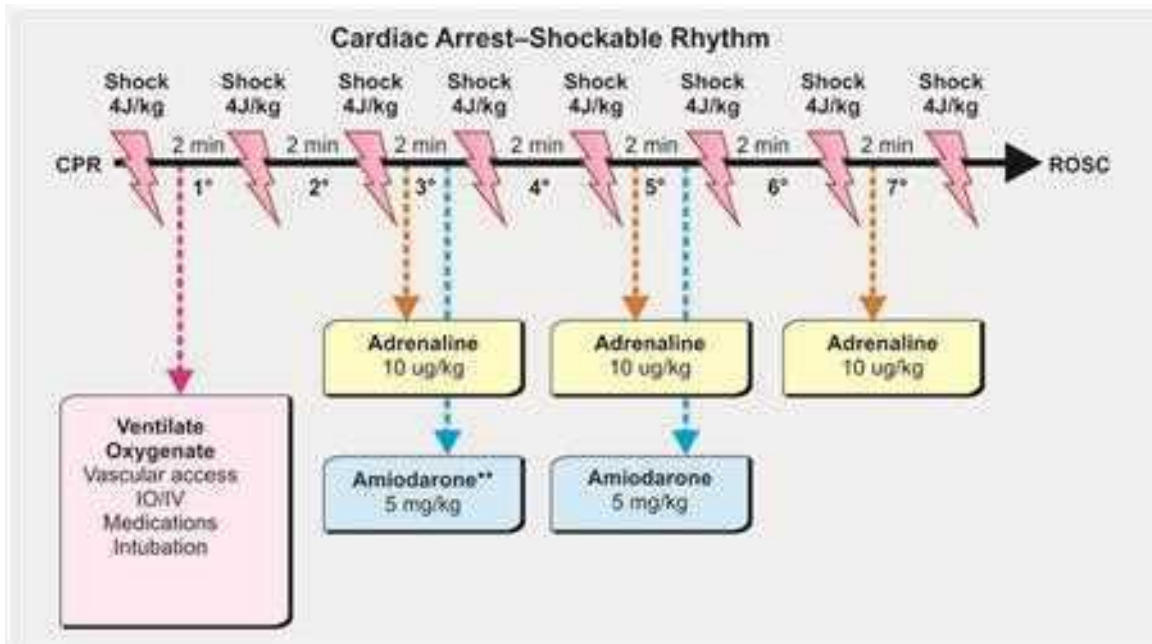


Fig. 30.4: Management of shockable rhythms

give a second shock and recommence another 2 minutes CPR. Recheck the rhythm again after completing 2 minutes CPR, if still in pulseless VT/VF give a third shock and recommence CPR. Following the third shock an intravenous or intraosseous dose of adrenaline [10 µg/kg (0.1 ml/kg of 1 in 10,000 adrenaline)] and a dose of amiodarone 5 mg/kg should be given. Cycles of 2 minutes CPR followed by defibrillation should continue until an organised rhythm is established. Further doses of adrenaline should be given every alternate cycle (every 3–5 min) and a second dose of amiodarone if still in pulseless VT/VF after the fifth shock.

5. *Non-shockable rhythm*: Continue CPR. Give adrenaline via the intraosseous or intravenous route [10 µg/kg (0.1 ml/kg of 1 in 10,000 adrenaline)] and repeat every 3–5 minutes.
6. Consider the reversible causes of cardiac arrest and treat if present.
7. Monitor blood sugar frequently and correct any hypoglycaemia.

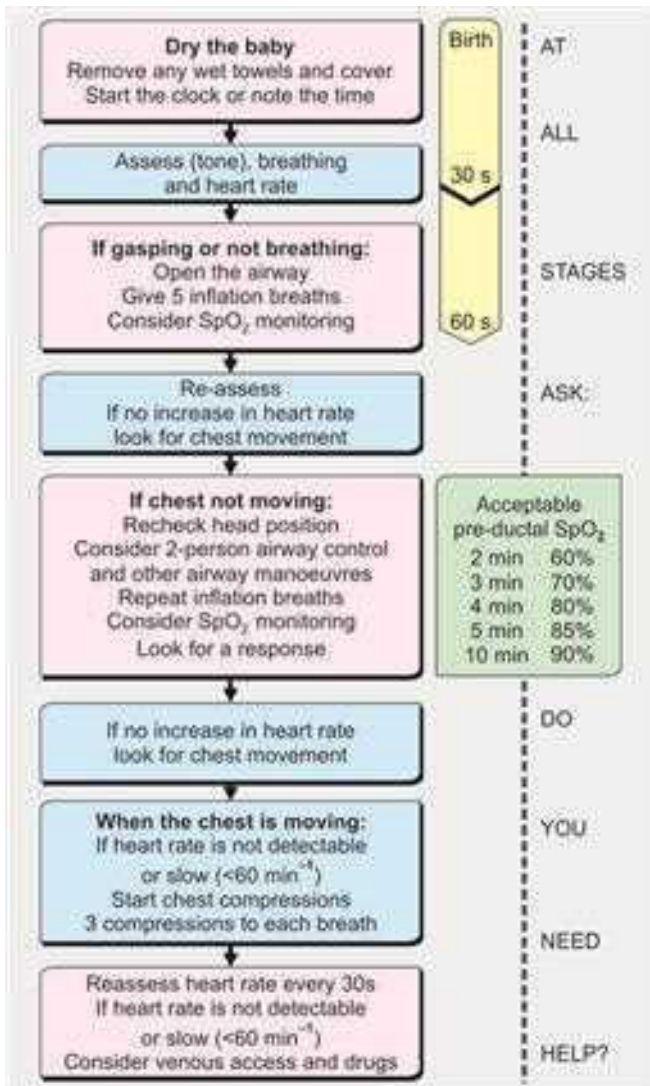
### Newborn Life Support

More information on the management of newborns is given in Chapter 3 'Neonatal Paediatrics'. There are a number of key differences between resuscitating newborn babies and children. When born the newborn baby is small, wet and naked, this means he is prone to hypothermia very quickly, even in warm climates. It is important, therefore, to dry and warm the baby as soon as possible as it is difficult to resuscitate a baby that is hypothermic. Additionally, the main

mechanism of cardiac arrest in newborn babies is usually asphyxia. The newborn infant's lungs are usually small and fluid filled. The emphasis is, therefore, upon delivering effective prolonged rescue breaths to allow adequate lung inflation thus permitting gas exchange and oxygenation to the oxygen starved brain and myocardium. The algorithm for newborn life support is shown in Figure 30.5.

### Post-arrest Management

Following cardiac arrest the patient should be referred to the intensive care unit for ongoing care. The key aims of management at this point are prevention of further cardiac arrest and minimisation of other end-organ damage, primarily protection of the brain. Cardiac dysfunction following cardiac arrest is common and is best managed by the use of vasoactive infusions of inotropes such as dopamine, adrenaline, noradrenaline and milrinone. The risk of further cardiac arrest in the setting of arrhythmia can be minimised by optimising serum electrolyte levels and possibly the addition of antiarrhythmics such as an amiodarone infusion. Maintaining an adequate blood pressure is important in ensuring an adequate cerebral perfusion pressure in a patient group that has experienced a period of compromised cerebral blood flow during the arrest period. In patients who remain comatose there is some evidence that a degree of neuroprotection may be afforded by avoiding hyperthermia and possibly inducing mild therapeutic hypothermia (32–34°C) for at least 24 hours with the use of external cooling combined with adequate sedation and muscle relaxants. Blood sugar should be monitored frequently and hypoglycaemia treated.



**Fig. 30.5:** Algorithm for newborn life support, Copyright, European Resuscitation Council, Source: www.erc.edu, 2011/001, Reproduced with the kind permission of the Resuscitation Council (UK)

### When to Stop Resuscitation?

The outcome following cardiac arrest in children is generally poor but is influenced by the situation of the arrest. A witnessed in-hospital VF arrest that is rapidly defibrillated may have a good outcome; an asystolic arrest out-of-hospital due to an obstructed airway generally has a poor outcome. When undertaking resuscitation it is important to be aware that the longer the resuscitation continues the less likely a favourable outcome becomes. In addition, it should be noted that survivors of prolonged resuscitations may be left with severe brain injury and significant neurodisability. Whilst every cardiopulmonary arrest is different consideration should be given to discontinuing ongoing resuscitation if the child is still requiring CPR beyond 20 minutes. The only

situation in which this does not necessarily apply is that of profoundly hypothermic children who have drowned in very cold water in which favourable outcomes have been documented in prolonged resuscitations.

### Key Learning Points

- Most cardiac arrests in children are due to respiratory failure/hypoxia or cardiovascular collapse rather than primary arrhythmia.
- The ABC approach should be used in the management of cardiac arrest and a team approach is essential.
- Five rescue breaths should be given to any child not breathing following airway opening manoeuvres.
- Bradycardia less than 60 beats/min is considered a cardiac arrest in children.
- Chest compressions should be commenced within 10 seconds of recognition of cardiac arrest—if in doubt, start chest compressions.
- Chest compressions should be 'hard and fast' and the importance of full release or 'recoil' noted following each compression.
- The compression ventilation ratio should be 15:2 in all age groups, except the newborn where it is 3:1
- Early defibrillation is critical in children with VF or pulseless VT.
- Practice using resuscitation mannequins and mock scenarios is an important for any clinician involved in the resuscitation of sick children.

### Recognition of the Sick Child and Prevention of Cardiac Arrest

It is important to be able to recognise when a child is seriously ill and therefore initiate appropriate therapy that may help prevent deterioration to the cardiac arrest situation. The process involved follows the 'Basic Structured Approach to Management' method outlined at the starting of the chapter and follows the principles of ABC. Once again it is emphasised that the key method is to identify and treat life-threatening abnormalities as they are recognised, using the ABC approach, rather than using precious time trying to identify the definitive diagnosis that can be established after the patient has been stabilised.

A, B, C is carried out in the standard format as in resuscitation manuals.<sup>1,2</sup> D for dextrose and disability and E for exposure are also added. For trauma, assessment and resuscitation are done as a primary and secondary survey and adding cervical collar for A and control of bleeding for C.

If there are enough persons available, several procedures can be done simultaneously. In the event that only one medical officer is available, it is vital to go through A, B, C, D, E in order and correct deficits as the problems are recognised (e.g. A should be satisfactorily corrected/completed before attempting to improve B and so on). Repeated assessments should be done after performing any action to note the

desired effect and if no/poor response, further treatment should be considered before proceeding to the next letter—all are recorded *in seriatum* and time oriented.

### Airway

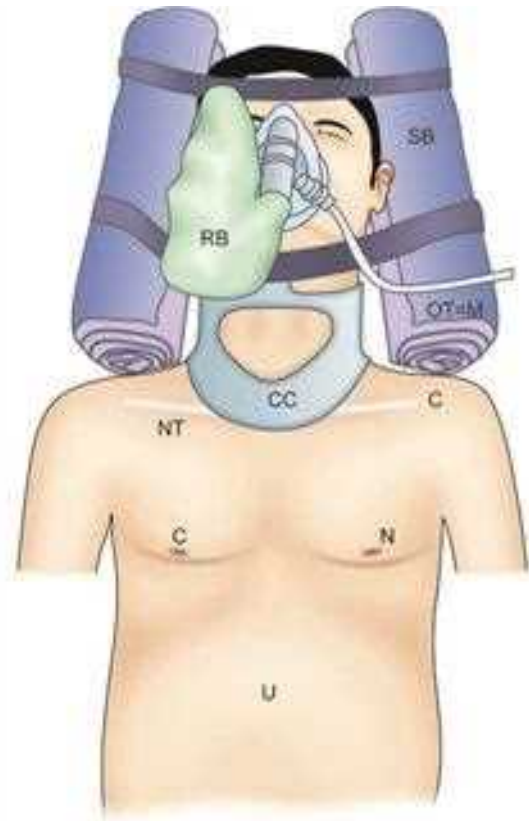
The airway is corrected with the patient in a neutral (infant) or sniffing position (children) with head tilt and chin lift (jaw thrust, without tilting, for trauma). Removal of secretions can be performed using a Yankauer sucker and visible foreign bodies in the mouth should be removed using Magill or similar forceps. Additional airway support, if necessary, can be given by the use of an oropharyngeal airway (Guedel airway) or nasopharyngeal airway. Nasopharyngeal airways should not be used in head-injured children who may have a basal skull fracture. If it is difficult to establish an airway despite these measures consideration should be given to either Laryngeal Mask Airway (LMA) placement or endotracheal intubation.

### Breathing

Oxygen should be delivered to all patients at maximum flow (15 L/min) via a face mask with a non-rebreathing reservoir bag until resuscitation is complete. The addition of an inflated reservoir bag allows oxygen concentrations close to 100% to be achieved. It is important to note that simple face masks and nasal cannulae can only deliver oxygen concentrations of between 24% and 50%, irrespective of oxygen flow rate and should not be used in the resuscitation environment. Continuous monitoring of oxygen saturation ( $SpO_2$ ) using a pulse oximeter applied to the finger or toe is useful to assess the severity of hypoxia and monitor response to treatment.

Air entry should be equal and adequate on both sides. Respiratory rate should be assessed as to whether it is within the normal range for a child of that age. Added sounds should be noted. Stridor suggests upper airway obstruction, wheeze suggests lower airway obstruction. Stridor should be managed with nebulised adrenaline and oral or IV dexamethasone if due to croup or antibiotics and nebulised adrenaline if due to epiglottitis. Stridor due to foreign body aspiration should be managed following the protocol documented above for Foreign Body Airway Obstruction and discussed with anaesthetic and ENT colleagues as a matter of urgency. Wheeze due to asthma should be treated with bronchodilators such as salbutamol and ipratropium with the addition of oral or IV steroids. Grunting suggests significant respiratory distress in an infant and its presence should alert the team that additional respiratory support may be required such as nasal CPAP or ventilation. Other signs suggesting significant respiratory distress include nasal flaring and subcostal, intercostal and suprasternal recession.

In the trauma patient if breathing is inadequate on one side, intrathoracic obstruction should be considered and



**Fig. 30.6:** Resuscitation of the trauma patient SB—SandBag, RB—Reservoir Bag, OT + M—Oxygen Tube and Mask, CC—Cervical Collar, NT—Needle Thoracocentesis, C—Clavicle, N—Nipple, U—Umbilicus

corrected. Tension pneumothorax should be managed with emergency needle thoracocentesis just under the midpoint of the clavicle followed by an intercostal drain [Fig. 30.6 (NT)]. Simple pneumothorax and haemothorax should be managed with an intercostal drainage placed in the fifth intercostal space (approximately the nipple line) in the midaxillary line. A sucking effect can be prevented with an occlusive dressing applied on three sides for open pneumothorax thus preventing progression to a tension pneumothorax. Endotracheal tube ventilation may be required for a flail segment when oxygen saturation cannot be improved.

### Circulation

Assessment of the circulation is based on heart rate, capillary refill time and blood pressure. Heart rate and capillary refill time are the most important of these variables. Tachycardia in children is an early sign of pending circulatory collapse and bradycardia should be treated as per cardiac arrest protocols. Unfortunately, the heart rate is also influenced by other variables such as pain, anxiety and pyrexia making its use in isolation problematic. Capillary refill time is another useful

measure of circulatory adequacy. Refill times greater than 2–3 seconds are suggestive of poor tissue perfusion, particularly if associated with tachycardia or bradycardia. Blood pressure is usually maintained in children until immediately prior to circulatory collapse and therefore the presence of a normal blood pressure does not exclude circulatory insufficiency. A dropping blood pressure is a late sign of shock and its presence requires immediate intervention.

Circulatory failure is initially treated with volume expansion. Venous access may prove difficult and if there is any delay in establishing venous access then the intraosseous route can be accessed easily and rapidly with an intraosseous needle. The fluid of choice for initial resuscitation is an isotonic crystalloid solution, e.g. 0.9% saline solution. Dextrose containing solutions should be avoided in the resuscitation phase unless hypoglycaemia is present as they fail to remain in the circulation and can cause hyponatraemia and cerebral oedema. Boluses of 0.9% saline (20 ml/kg) should be given rapidly over 5–10 minutes and response to treatment assessed after each bolus by assessing heart rate, refill time and blood pressure. Further, boluses should be administered up to 60 ml/kg total volume if necessary. If signs of circulatory failure persist despite 60 ml/kg of volume resuscitation then an inotropic drug infusions should be commenced. Dopamine, dobutamine or adrenaline infusions should be considered in the first instance. Dopamine and dobutamine have the advantage of being safely given via a peripheral line. Adrenaline should ideally be given via a central venous line but weak concentrations can be given peripherally in the resuscitation scenario. In the case of vasodilated septic shock the addition of noradrenaline may be useful. If more than 60 ml/kg volume replacement is required then the child should be intubated and ventilated. This is for several reasons. The administration of large volumes of fluid frequently results in pulmonary oedema which can be easily managed with mechanical ventilation. Positive pressure ventilation also provides additional inotropic support to a failing left ventricle by reducing after load. In addition, by removing the work of breathing positive pressure ventilation reduces the metabolic demand on the body and allows the cardiac output to redistribute to other organs such as the brain, kidneys and heart. If further fluid is required it can be administered as blood to increase the oxygen carrying capacity in addition to filling the vascular compartment. In the trauma patient attempts should be made to control any obvious source of ongoing haemorrhage.

### *Don't Ever Forget Glucose (DEFG)*

All patients should have a blood glucose level checked. This can usually be done quickly and accurately with a near-patient glucometer machine. Children have small livers and limited glycogen stores that are rapidly depleted when unwell and as

such are prone to hypoglycaemia. Additionally, infants can present collapsed with hypoglycaemia as part of a metabolic disorder. If the finger prick (BM) and/or laboratory blood sugar is below 3 mmol/L, a bolus injection of glucose should be administered. The dose is as follows.

*5 ml/kg of 10% dextrose (0.5 g/kg)*

Maintenance fluids should contain dextrose (e.g. 0.9% saline + 5% dextrose) to avoid hypoglycaemia and should be commenced as soon as possible if the child is not able to eat or drink.

### *Disability*

It can be assessed using Glasgow coma score (GCS) and/or alert, response to voice/pain or unresponsive (AVPU), size, reaction and equality of both pupils and neurological examination including the position of the patient (decorticate or decerebrate). Though many are important, oxygen and blood sugar are the two most vital elements to sustain some basic cerebral functions. The brain can be insulted by many different ways, but reduced oxygen and sugar will derange the brain sufficiently to disturb all other functions. Sufficient oxygen should be made available to the brain, by effective oxygenation and oxygen delivery using the ABC approach. Fixed pupils and abnormal posturing are ominous signs that suggest raised intracranial pressure. In their presence mannitol should be given and arrangements should be made for urgent transfer to the CT scanner whilst the neurosurgical team is contacted.

### *Exposure*

The team can cut the clothes and remove the footwear so that A, B, C, D can be assessed better. When the patient is lying, supine examination can be done for only 50% of the body. It should be remembered that there is another 50% to be examined on the dorsal aspect in case other significant injuries are missed. Coordinated effort to turn the patient as 'log roll' (three or four persons according to the size of the patient)<sup>1,2</sup> allow safe examination of the patients back and preserve the existing neurological function even in the presence of vertebral injury.

### **Key Learning Points**

- Recognition of the sick child is a critical component of emergency paediatric care.
- Management should be based on an ABC approach and problems dealt with as they are encountered.
- High flow oxygen should be given via a face mask with an inflated reservoir bag.
- A normal blood pressure does not mean that the circulation is adequate.
- Hypotension is a late, pre-terminal sign and needs immediate treatment.

- ➔ Volume resuscitation should be given with 0.9% saline or other isotonic fluid.
- ➔ Dextrose-containing fluids should not be given for volume resuscitation.  
Bolus IV dextrose should only be given if the child is hypoglycaemic.
- ➔ Hypoglycaemia is common in sick children. Blood sugar should be monitored frequently and treated if found to be low.
- ➔ Commence inotropes if > 60 ml/kg volume resuscitation is required and consider intubation and ventilation early if no response to therapy.
- ➔ An urgent CT head scan and neurosurgical referral is important in children

## PAEDIATRIC EMERGENCIES

### Sepsis

Infection and septicaemia are one of the leading causes of death in childhood. The range of organisms that cause septicaemia is wide and the initial presentation is often non-specific with parents reporting symptoms such as poor feeding, lethargy or irritability, fever and rash. The onset may be very rapid over the space of a few hours or more insidious over several days. Some organisms have a distinctive pattern of presentation, for example, meningococcal sepsis due to *Neisseria meningitidis* frequently presents with the rapid onset of a spreading, non-blanching purpuric rash making diagnosis relatively simple. Other organisms, particularly in young children, often present in a more non-specific manner, for example, Group B streptococcal infection in a newborn may present simply with poor feeding and lethargy. Fever in infants less than 3 months old should be assumed to be due to bacterial sepsis until proven otherwise. This means that the early initiation of a broad spectrum antimicrobial agent (for example, a third generation cephalosporin) is essential until culture results are available.

The approach to resuscitation in sepsis follows the ABC approach outlined above and is identical irrespective of the organism. The main system involved is often circulatory collapse and as such large volumes of isotonic fluid resuscitation are often required. Early, aggressive fluid resuscitation has been demonstrated to improve outcomes and is a priority. A low threshold for the early use of inotropes (if requiring more than 60 ml/kg fluid resuscitation) and referral to intensive care for mechanical ventilation is important as patients with sepsis can frequently deteriorate rapidly. Resuscitation efforts can be assessed by looking at factors such as heart rate, capillary refill time, blood pressure, urine output and blood parameters such as blood lactate levels and mixed venous saturation. The strategy of aggressive fluid resuscitation combined with the use of inotropes and mechanical ventilation if required is known as 'Early goal-directed therapy'. As mentioned above,

antibiotics should be given early (within minutes of arrival in the emergency department and absolutely within 1 hour) as any delay in their administration is associated with increased mortality. If possible blood cultures should be obtained prior to administration of antibiotics to guide later therapy although antibiotics should not be delayed if obtaining cultures is difficult. If the patient is first seen in the community, antibiotics (e.g. intramuscular benzylpenicillin) should be administered whilst waiting for the ambulance service.

A raised white cell count and C-reactive protein (CRP) level are often seen in sepsis, although in patients with severe sepsis the white cell count is frequently depressed and the CRP level may be unremarkable. If the focus of infection is unclear, particularly in infants, a septic screen including urine culture and lumbar puncture should be performed. In patients presenting unwell with shock, antibiotics should be given early and lumbar puncture should be delayed until they are stable.

#### Key learning points

- ➔ Presentation of sepsis in children is often non-specific.
- ➔ Fever in an infant less than 3 months old should be treated as bacterial sepsis until proven otherwise.
- ➔ Broad spectrum antibiotics should be given as soon as possible—do not delay therapy waiting for laboratory results.
- ➔ Resuscitation should follow the ABC approach.
- ➔ Early aggressive fluid resuscitation is critical in children with septic shock.
- ➔ A low threshold should exist for the use of inotropic drugs and early referral to intensive care.
- ➔ Once the definitive diagnosis has been established the antibiotics should be altered to a narrower spectrum.

### Diabetes

#### Hypoglycaemia

Symptomatic hypoglycaemia (confusion, jitteriness, seizures, coma) should be corrected when the glucose stick test (finger/heel prick BM) indicates blood sugar less than 3 mmol/L.

5 ml/kg of 10% dextrose, i.e. 0.5 gm/kg in peripheral IV/IO lines

#### Diabetic Ketoacidosis

The risk of diabetic ketoacidosis (DKA) in patients with known diabetes mellitus is 1–10% per patient per year. This risk is increased in patients with poor diabetic control. DKA at initial diagnosis of diabetes is more common in children less than 5 years old. The mortality rate in the developed world is approximately 0.13–0.15% and cerebral oedema is the mode of death in most instances.



The biochemical criteria for DKA are:

- Hyperglycaemia > 11 mmol/L
- Venous pH < 7.3 or plasma bicarbonate < 15 mmol/L
- Ketonemia or ketonuria.

The basic goals of therapy are to correct dehydration, correct acidosis and reverse ketosis, restore blood glucose to near normal and avoid complications of therapy. It is important to recognise that correction of DKA should be a gradual process over approximately 48 hours as rapid correction of blood glucose and excessive fluid administration is associated with an increased risk of cerebral oedema. National and international guidelines exist to aid the management of DKA.<sup>6,7</sup>

The key features of the management of DKA are as follows:

1. Initial fluid resuscitation over the first 1 hour with 0.9% saline if the patient is shocked. Usually the maximum fluid resuscitation should be 10–20 ml/kg and only exceptionally is more than this required as resuscitation fluid.
2. Commence insulin infusion at 0.1 units/kg per hour after fluid resuscitation has taken place over the 1st hour. This is because restoration of circulating blood volume often results in a significant reduction in blood glucose due to a combination of improved glomerular filtration rate and dilution. Commencing insulin early may accelerate the rapid drop in blood sugar and increase the risk of cerebral oedema. The aim is to reduce the blood sugar slowly and to prevent drops of greater than 5 mmol/L per hour. The insulin infusion should normally remain at 0.1 u/kg/hr to slowly normalise blood sugar and suppress lipolysis, ketogenesis and acidosis.

50 units soluble insulin added to 50 ml 0.9% saline = 1 unit/ml.  
Run infusion at 0.1 units/kg per hr (equivalent to 0.1 ml/kg per hr)

3. *Correct dehydration slowly:* Fluid replacement should take place over 48 hours. Usually the fluid deficit is calculated as 5% of total bodyweight in moderate DKA and 10% of bodyweight in severe DKA and is added to maintenance fluids. Resuscitation fluids administered should be subtracted from the total. Initial fluid management should be with 0.9% saline or Ringer's Lactate for at least 6 hours. Thereafter, the minimum tonicity of any replacement fluid should be 0.45% saline, although more commonly 0.9% saline is used throughout. Hypotonic fluids are not appropriate. When the plasma glucose is 14–17 mmol/L then 5% glucose should be added to the infusion fluid (i.e. 0.9% saline/5% dextrose or 0.45% saline/5% dextrose). The key principle of fluid replacement is to rehydrate whilst avoiding rapid changes in effective osmolality which may increase the risk of cerebral oedema.

Effective osmolality =  $[2 \times (Na + K)] + \text{Glucose}$ .

The effective osmolality should be protected and only allowed to drop slowly (1.5–2 mOsm/hr). Hyponatraemia is commonly seen in DKA due to osmotic shifts in water from the intracellular compartment to the extracellular compartment and due to an elevated lipid fraction that has a low sodium content. Plasma sodium levels are therefore unreliable at estimating levels of dehydration. As the plasma glucose falls the plasma sodium usually rises and effective osmolality should remain stable. If the effective osmolality falls rapidly then the sodium or glucose levels of the rehydration fluid may need to be changed e.g. increase glucose concentration to 10%. It may even be necessary to reduce the insulin infusion to 0.05 units/kg per hr if the blood glucose or effective osmolality continue to drop precipitously despite fluid alterations, although the insulin infusion must never be stopped.

4. *Potassium replacement:* Patients presenting with DKA typically have a low total body potassium level. As soon as it is established that the patient is passing urine and not in renal failure potassium replacement should be started early (add 40 mmol KCl/1000 ml of replacement fluid). ECG monitoring should be instituted due to the risk of arrhythmia.
5. *Avoid bicarbonate:* The acidosis seen in DKA is a result of ketoacid production and dehydration. It slowly resolves with the administration of insulin and fluid. There is no clinical benefit from the use of bicarbonate and its use may be associated with an increased risk of cerebral oedema. The only occasion when bicarbonate may be useful is in selected patients with severe acidosis (pH < 6.9) with resulting haemodynamic compromise.
6. *Be aware of cerebral oedema:* The mechanism of cerebral oedema in DKA is complex and not fully understood. It is associated with excessive fluid administration, rapid changes in blood glucose and effective osmolality although it is also seen in patients who have received no therapy. Cerebral oedema usually presents clinically 4–12 hours after starting treatment but can be seen at any time from diagnosis up to 48 hours later. Clinical features include headache, vomiting, altered level of consciousness, cranial nerve palsies and abnormal posturing. Management is with mannitol and referral to intensive care for intubation and ventilation.
7. *Treat underlying cause:* In some cases DKA may be precipitated by an underlying condition such as an infection. If such a cause is identified it should be treated.

**Key Learning Points**

- ➔ The aim is to correct blood sugar and dehydration slowly over 48 hours.
- ➔ Insulin should be run at 0.1 units/kg/hr.
- ➔ Avoid hypotonic fluids.
- ➔ Be aware of hypokalaemia.
- ➔ Do not routinely use bicarbonate therapy.
- ➔ The biggest risk of death is cerebral oedema.
- ➔ Look for and treat underlying precipitating reasons for DKA such as infection.

**Poisoning**

Iron, tricyclic antidepressants, opiates, paracetamol, salicylates, etc. are some of the commonly ingested medications with high fatality rates. In any unconscious child without a clear history suggestive of illness ingestions of medications or toxins should be considered. The patient should be stabilised and deficits of A, B, C, D, E addressed while waiting for the results of poison profile tests in blood and urine when the medications or toxins are unknown. Specific antidotes should be given in appropriate doses when the substance is identified. For example N-acetylcysteine in paracetamol overdose. Charcoal should be used carefully in certain indications and not as routine. It must not be used unless the airway is secure as aspiration of charcoal can result in significant lung injury.

Accidental ingestion is more common in infants and young children although deliberate ingestions are not uncommon in older/teenage children (Chapter 19 "Accidental Poisoning in Childhood").

**Seizures**

Seizures are common in childhood and a common cause of presentation to the emergency department. The commonest cause of seizures in childhood is a simple febrile convulsion which often resolves spontaneously without intervention. The differential diagnosis, however, includes hypoglycaemia, meningitis or encephalitis, epilepsy, hypertensive encephalopathy and raised intracranial pressure. It is important to note that whilst the differential may be diverse, the initial management is identical in all cases and involves following the ABC approach outlined earlier and the Emergency Treatment of Convulsion protocol outlined below (Fig. 30.7).

The key components of the Emergency Treatment of Convulsion protocol are as follows:

1. Commence high flow oxygen and check blood sugar as soon as possible. Treat any hypoglycaemia.
2. Insert an IV cannula and give IV lorazepam (0.1 mg/kg). If IV access is not possible then rectal diazepam

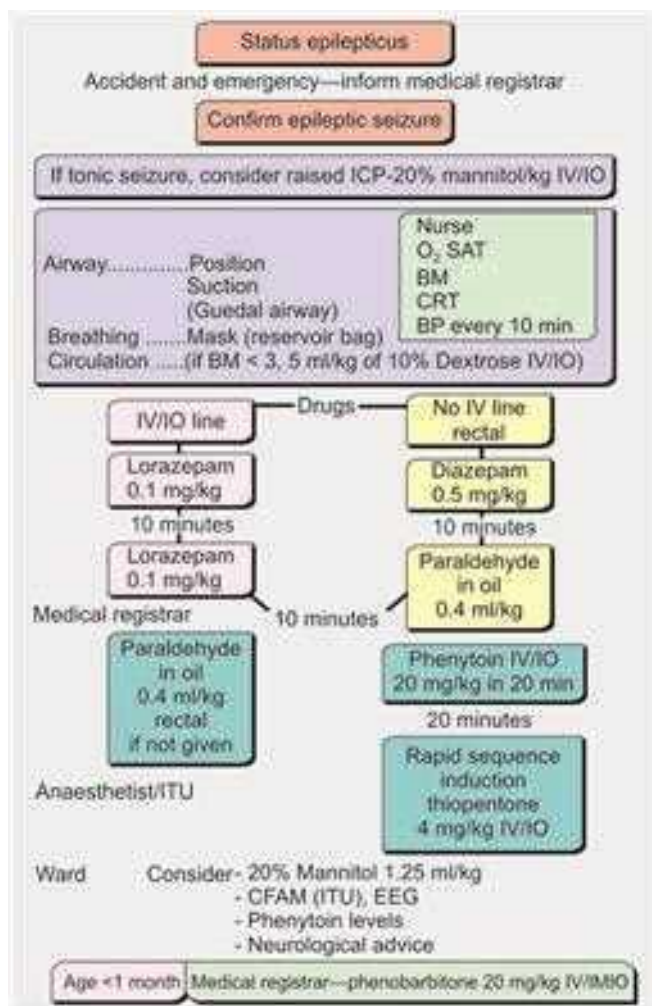


Fig. 30.7: Emergency treatment of the convulsing child

(0.5 mg/kg) or buccal midazolam (0.5 mg/kg) can be given. Lorazepam is the initial drug of choice if an IV line is available as it is equally efficacious as diazepam at terminating seizures but has a longer duration of action and causes less respiratory depression than diazepam. Buccal midazolam is fast-acting and effective but its duration of action is less than lorazepam. The correct dose can be drawn up from the IV preparation and injected (without an attached needle) into the buccal mucosa between the gum and bottom lip. This method of administration is easier and more socially acceptable than the rectal route for diazepam, although rectal diazepam remains an effective alternative.

3. *Wait for 10 minutes*: This is important as in many cases the seizure will terminate if the drugs are given time to work. If further doses of benzodiazepine are given before 10 minutes the chance of respiratory depression is increased. If this occurs it can usually be managed

with simple airway opening manoeuvres and bag or mask ventilation.

4. If vascular access is still not available a dose of rectal paraldehyde should be given. This should be made up in equal volumes of saline or olive oil. It is frequently stated that paraldehyde needs to be given in a glass syringe. This is not necessary and paraldehyde can be drawn up in a plastic syringe so long as it is not allowed to stand in the plastic syringe for more than a few minutes.
5. If venous access is available then a second dose of lorazepam should be given after 10 minutes.
6. If still seizing after another 10 minutes (total 20 minutes since first dose of lorazepam or midazolam/diazepam) then an IV loading dose of phenytoin should be given over 30 minutes. If paraldehyde has not been given at this stage it should be given whilst the phenytoin is being prepared.
7. If after administration of phenytoin the child is still fitting, then the child will required to be intubated and ventilated using thiopentone as an induction agent. Normally, this would not be done until approximately 40–50 minutes after the first dose of benzodiazepine as time must be given for subsequent doses of lorazepam, paraldehyde and phenytoin to work. An anaesthetist or intensivist should be involved at this stage as ongoing care will be required in the intensive care unit.
8. Treat the underlying cause, for example, antibiotics in meningitis (do not do a lumbar puncture in a fitting child or child with reduced level of consciousness!). Most cases of simple febrile convulsion require no further treatment once the seizure has been terminated.

It is important to recognise the difference between seizures and abnormal posturing (decorticate or decerebrate) due to raised intracranial pressure. In the event of raised intracranial pressure management should be directed towards reducing the intracranial pressure with intravenous mannitol, intubation or ventilation, urgent CT brain imaging and neurosurgical intervention.

#### Key Learning Points

- Approach the convulsing child with the usual ABC approach.
- Check blood sugar early as hypoglycaemia can result in seizures.
- Allow anticonvulsant drugs time to work—too rapid administration of further doses of benzodiazepenes are likely to cause respiratory depression.
- Be aware that abnormal posturing with reduced level of consciousness may result from raised intracranial pressure and may be confused with a simple seizure.
- Treat the underlying cause.

## Respiratory Distress

Reduction in the diameter of the airway is a common reason for acute respiratory distress in the paediatric age. Larger airways like the trachea and bronchi may be narrowed due to infection such as croup (laryngotracheobronchitis), epiglottitis or bacterial tracheitis as well as foreign bodies or tumours. Smaller airways may be narrowed in conditions such as asthma or bronchiolitis. It is important to remember that resistance to gas flow in the airway is inversely proportional to the airway radius to the power of 4 ( $1/r^4$ ) and as such even small reductions in radius can result in a significant reduction in gas flow. As a general rule, upper airway obstruction results in stridor and lower airway obstruction in wheeze. Severe infection like pneumonia affects the parenchymal function and reduce the airspace available for gas exchange.

## Epiglottitis

Due to compulsory vaccination against Haemophilus Influenza B (HiB) the incidence of epiglottitis is declining in many countries, but this remains a life-threatening disease in the unvaccinated childhood population. Acute respiratory distress not settling or rapidly progressing over a few hours accompanied by stridor, should alert the practitioner as to the possibility of epiglottitis. Other features such as a sick ‘toxic looking’ child, high fever and the inability to speak or whisper, especially if accompanied by drooling due to inability to swallow secretions should help differentiate epiglottitis from croup. In such a compromised airway, care needs to be taken to prevent progression to complete airway obstruction. As such, it is important to avoid upsetting the child. For example, no attempt should be made to examine the child’s throat or remove the child from their parent. Immediate explanation and oxygen by mask, held by mother, whilst administering nebulised adrenaline should be attempted while awaiting arrival of an anaesthetist and ENT surgeon to secure the airway with intubation or possibly tracheostomy or needle cricothyroidotomy. A cephalosporin, such as cefotaxime and steroids, should be given when the airway is controlled.

#### Key Learning Points

- Epiglottitis is a medical emergency.
- Give high flow oxygen and nebulised adrenaline.
- Do not examine the child’s throat.
- Call anaesthesia and ENT as an emergency.
- Start IV cefotaxime.

## Croup (Laryngotracheobronchitis)

In croup larger and proximal air passages are narrowed due to inflamed and oedematous mucosa of the respiratory tract.

The typical presentation is of a well-looking child with a barking cough and stridor and a prodromal upper respiratory tract infection. Occasionally, the child may be unwell when the diameter of the proximal passage is narrowed enough to result in hypoxia. In most cases, croup is self-resolving. Unwell patients should be given oral or intravenous steroids (dexamethasone). An alternative is nebulised budesonide. In the presence of stridor and respiratory distress the child should be given nebulised adrenaline. It is important to recognise that the presence of hypoxia suggest pending complete airway obstruction and is an emergency. If the child fails to respond promptly to steroids and nebulised adrenaline, endotracheal intubation and ventilation is required. Intubation should be attempted by expert anaesthetist, using the tube with considerably less diameter.

#### Key Learning Points

- Treat croup with oral, IV or nebulised steroids. If respiratory distress is present nebulised adrenaline may be useful.
- The presence of hypoxia is an emergency as it suggests pending complete airway obstruction.

## Asthma

Acute exacerbation of asthma is one of the commonest respiratory presentations to the emergency department. It is approached using the usual ABC approach. Assessment of severity is based upon respiratory rate, SpO<sub>2</sub>, peak flow and heart rate. Severe and life-threatening asthma are distinguished by an inability to feed or talk, exhaustion, reduced level of consciousness and a silent chest on auscultation. It is important to initiate early, aggressive therapy. If the patient responds favourably then treatment can be reduced. The key features of the management of asthma are as follows:

1. High flow oxygen via face mask and reservoir bag. Attach SpO<sub>2</sub> monitor.
2. Give short-acting beta-agonist (salbutamol). If the child is stable, this is best given as 10 puffs of a pressurised inhaler via a spacer. If the child is unwell and requires oxygen, it should be given via an oxygen-driven nebulizer (2.5 mg in under 5 year olds, 5 mg in over 5 year olds). If unwell, the nebulizer or spacer should be repeated at 20 minute intervals for the 1st hour and thereafter 1–4 hourly depending on response to treatment.
3. Give oral prednisolone (1 mg/kg) or IV hydrocortisone (4 mg/kg) if unable to use the oral route.
4. Add nebulised ipratropium bromide 250 µg if not responding to treatment. This can be repeated at 20 minute intervals.
5. If poor response to therapy or deterioration then add the following:
  - A. Bolus IV salbutamol followed by continuous infusion salbutamol.

- B. Bolus IV aminophylline followed by continuous infusion.
  - C. Bolus IV magnesium sulphate (25–40 mg/kg) over 20 minutes.
6. If not responding or deteriorating then refer to intensive care for trial of either non-invasive mask ventilation (mask BiPAP) or intubation and invasive ventilation. Investigations such as CXR are rarely helpful unless pneumothorax is suspected. Likewise, antibiotics are rarely indicated unless it is felt that the exacerbation has been triggered by a bacterial infection.

#### Key Learning Points

- The asthmatic child unable to talk in an emergency. Exhaustion is a preterminal event.
- Treat acute exacerbations of asthma aggressively then de-escalate therapy as the child improves.
- Start steroids early.
- Do not be afraid to use intravenous salbutamol, aminophylline and magnesium.
- Salbutamol administration via an inhaler and spacer is the delivery mechanism of choice in the non-oxygen-dependent child. If the child is oxygen-dependent, salbutamol should be given via an oxygen-driven nebuliser.

## Bronchiolitis

Hypoxia can be resulted when the small air passages are further narrowed due to inflammation in young babies and infants. Most of the patients can be managed at home but may require hospitalisation if hypoxia and/or feeding is sufficiently interfered. Moderately, ill infants can be treated with high flow oxygen (mask and reservoir bag) until stabilised when nasal prong oxygen usually suffices. Fluid and nutrition is best managed with nasogastric tube feeding, if too breathless to feed. Intravenous fluids are rarely required. It is important to realise that unwell infants with bronchiolitis tend to have raised levels of antidiuretic hormone (SIADH) and are, therefore, at risk of hyponatraemia. Once any element of shock has been reversed, it is important to moderately restrict fluid input (approximately 75–80% normal maintenance) until the child is well enough to feed themselves and thus regulate their own fluid balance. If the infant fails to respond to nasal prong oxygen the use of nasal CPAP is often useful. Patients who fail to respond to nasal CPAP should be treated with endotracheal tube ventilation and transferred to ICU after stabilising. Disappointingly, there is little evidence to suggest benefit of any other therapies. Antibiotics and steroids are not considered beneficial, although there is some emerging evidence that the combination of nebulised adrenaline plus oral dexamethasone may help reduce in-patient admissions from the emergency department.

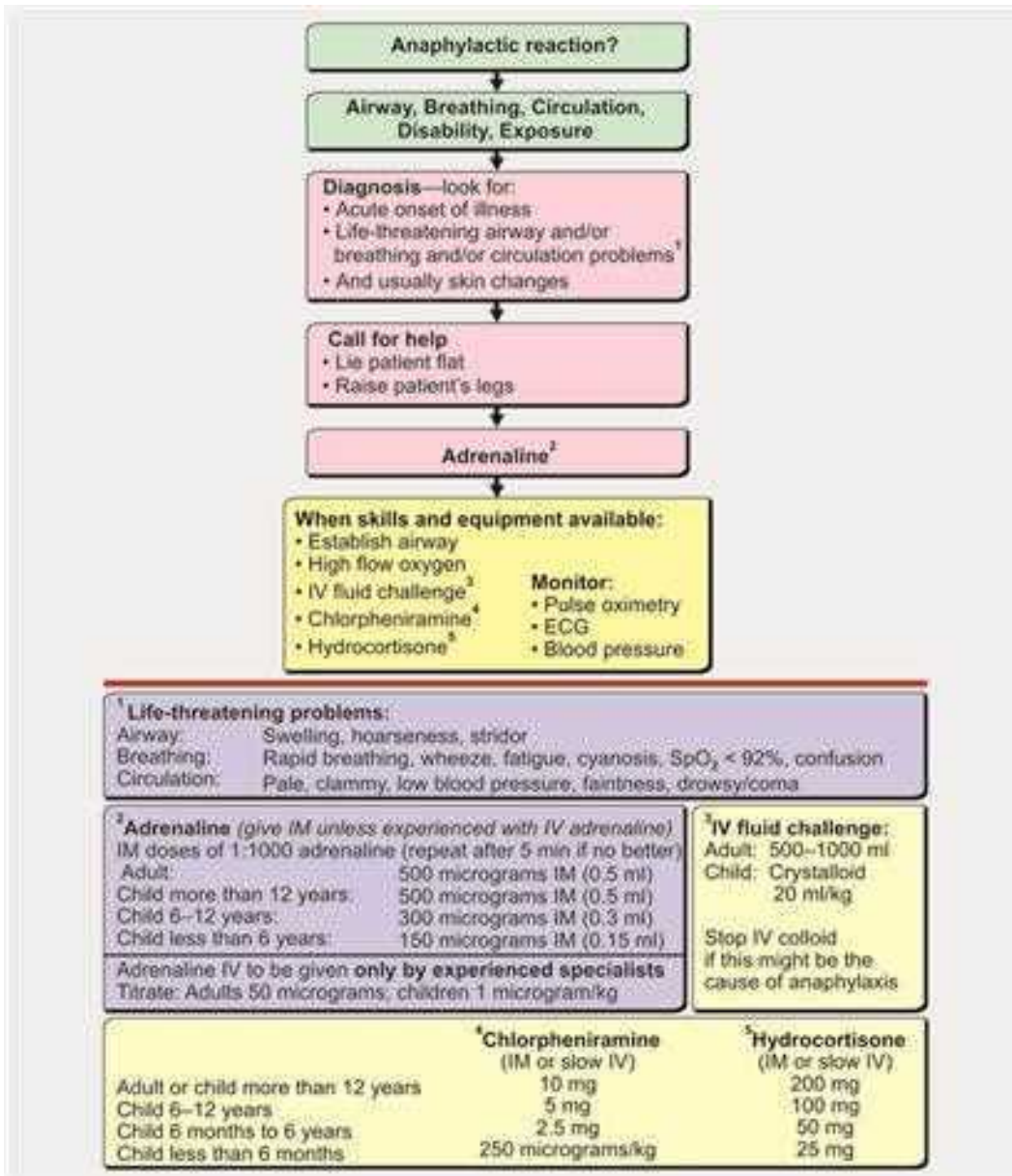


Figure 30.8: Emergency management of anaphylaxis (Reproduced with the kind permission of the Resuscitation Council, UK)

## Anaphylaxis

Anaphylaxis is a life-threatening allergic reaction that can occur to a wide variety of stimuli and may occur at any age. Common allergens that may precipitate anaphylaxis include nuts, milk, other foods and some common medications, e.g. penicillin. The management remains the same irrespective of the precipitating allergen and is shown in Figure 30.8. The key factors involved in any anaphylactic reaction are airway swelling and obstruction, and circulatory collapse. Airway swelling can occur at any level of the respiratory tract from the lips to the larynx (causing laryngeal oedema,

stridor and airway obstruction) to the distal airways causing wheeze identical to asthma. Circulatory collapse and shock occurs secondary to profound vasodilatation, secondary to the release of histamine and other vasoactive inflammatory mediators.

Treatment of anaphylaxis follows the standard ABC approach. Intramuscular adrenaline should be given early and can be repeated after 5 minutes if there has not been significant improvement. Anti-histamines (IM or slow IV chlorpheniramine) and steroids (IM or slow IV hydrocortisone) should be given. Once IM adrenaline has been given but

they may have a delayed onset. Stridor should be treated with nebulised adrenaline and steroids. Wheeze should be treated as per asthma. Shock should be treated with volume resuscitation and IM adrenaline. An adrenaline infusion may be required if the patient remains unstable despite these measures.

### Collapsed Neonate

Infants presenting collapsed in the first few days of life provide a unique challenge to the paediatrician. Common aetiologies in this age group include sepsis, duct-dependent cardiac lesions and inborn errors of metabolism. All can present in a similar fashion making early diagnosis challenging. It is, therefore, important to have a structured approach concentrating on ABC that covers the most likely diagnoses.

#### Sepsis

Sepsis causing organisms include Group B *Streptococcus*, *E Coli*, *Klebsiella* and *Listeria*. Antibiotics that cover these organisms should be given early to any collapsed neonate, e.g. cefotaxime plus amoxicillin.

#### Duct-dependent Cardiac Lesion

Pulmonary obstructive lesions, such as pulmonary atresia, critical pulmonary stenosis, tricuspid atresia and transposition of the great arteries, can present collapsed with severe cyanosis when the ductus arteriosus closes after a few days of life. Systemic obstructive lesions, such as coarctation of the aorta, critical aortic stenosis and hypoplastic left heart syndrome, can also present with collapse and may or may not be cyanosed depending on the general state of the child. Classically, infants with systemic obstructions present with absent femoral pulses, but it should be noted that in any collapsed neonate palpation of any pulse is often difficult if the patient is shocked. Infants with heart failure also frequently have a heart murmur and enlarged liver.

The treatment of a duct-dependent cardiac lesion follows the standard ABC approach. In addition, an infusion of prostaglandin should be started in any collapsed neonate in which a duct-dependent lesion is suspected. Inotropic support is also frequently required.

#### Maintenance of Ductal Patency

- Alprostadil (Prostin VR)—to open duct commence at 50–100 nanograms/kg per min then titrate to lowest effective dose (usually 5 nanograms/kg per min).

OR

- Dinoprostone (Prostin E2)—to open duct commence at 20–100 nanograms/kg per min then titrate to lowest effective dose (usually 5 nanograms/kg per min)

The most significant side effect of prostaglandin is the occurrence of apnoea. This tends to be dose-dependent. If apnoea is troublesome, intubation and ventilation may be required.

#### Inborn Error of Metabolism

These children may present after a period of apparent normality after feeding on breast milk or standard formula at home. They may present collapsed with a profound metabolic acidosis and hypoglycaemia. Management is with the ABC approach. Bicarbonate infusions may be required. The key is to properly resuscitate the infant and provide a source of glucose in the short term whilst feeds are stopped pending further investigations.

#### Key Learning Points

- ➔ In any collapsed neonate the possibility of sepsis, duct-dependent congenital heart disease or an inborn error of metabolism should be considered.
- ➔ Commence broad spectrum antibiotics in any collapsed neonate.
- ➔ Have a low threshold for commencing a prostaglandin infusion.
- ➔ Note that the dose of prostaglandin is in nanograms/kg per minute.
- ➔ Stop feeds and provide a glucose source if a metabolic disorder is thought likely.

#### Trauma

The child with trauma should be approached. Following the same ABC approach as described earlier. The only difference is that cervical spine control should be assessed and managed at the same time as the airway.

#### Radiological Investigations

Any child with significant trauma, particularly if they have a reduced level of consciousness or distracting painful injury, should undergo a number of standardised radiological investigations known as a 'trauma series'. These include plain radiographs of the cervical vertebrae (two views in children under 10 years, three views in children over 10 years), AP chest and pelvis. Time should not be wasted for X-ray chest, if tension pneumothorax is suspected and treatment (needle thoracocentesis, at the lower border of the midpoint of clavicle) should be carried out immediately.

#### Head and Neck Injury

In the head injured patient cerebral functions may be depressed due to raised intracranial compression secondary to oedema and/or bleeding. This can result from both

localised injury and bleeding as well as more diffuse head injury resulting in diffuse axonal injury. In head injuries with raised intracranial pressure and subsequent compression of the brain, Cushing's triad (altered consciousness, slow pulse rate and increased blood pressure) is often noted. Therefore, increased pulse rate and/or low blood pressure should raise the suspicion of trauma and bleeding elsewhere in chest, abdomen, pelvis or major bony injuries rather than concentrating on the head injury in isolation. The mechanism of injury may also indicate the potential severity of the injury. High speed impacts and road traffic accidents with fatalities point to a high likelihood of significant injury as do falls from a reasonable height. If there is any suspicion of head injury then an urgent CT head scan should be performed. A CT scan of the cervical spine may be done at the same time if there is a severe head injury (GCS < 8) or if the plain films are inadequate or there remains strong suspicion of injury despite normal plain films.

Patients who should undergo a CT head scan have been identified in the UK National Institute of Clinical Excellence Head Injury guidelines.<sup>8</sup> They are as follows:

#### Indications for urgent CT head scan:

- Witnessed loss of consciousness lasting greater than 5 minutes
- Amnesia lasting greater than 5 minutes
- Abnormal drowsiness
- Three or more discrete episodes of vomiting
- Clinical suspicion of non-accidental injury
- Post-traumatic seizure with no history of epilepsy
- Age greater than 1 year with GCS less than 14; age less than 1 year with GCS less than 15
- Suspicion of open or depressed skull fracture or tense fontanelle
- Any sign of basal skull fracture
- Focal neurological deficit
- Age less than 1 year with presence of bruising, swelling or laceration greater than 5 cm on the head
- Dangerous mechanism of injury

The key aspects of head injury management are as follows:

1. *ABC approach to management*: Ensure adequate oxygenation and blood flow to the injured brain. Apply high flow oxygen and resuscitate.
2. *Cervical spine control*: Apply hard collar and sandbag/tape head on spinal board at same time as performing ABC (Fig. 30.6).
3. *GCS less than 8*: Intubate and ventilate.
4. *Urgent imaging of brain*: Identify any surgically amenable lesion early.
5. Involve neurosurgeons early.
6. Search for and treat any other injuries.

All patients with significant abnormalities on CT scanning should be referred urgently to a neurosurgeon. In addition, regardless of the imaging findings, patients should be discussed with a neurosurgeon if significant clinical concerns continue despite adequate resuscitation.

When a head injury is severe enough to result in a depressed conscious level (GCS < 13), injury to the cervical vertebra should be presumed to be present until later neurological and radiological investigations (plain X-rays and, if necessary, CT or MRI) are proven to be normal. It is important to be aware that children are at risk of spinal cord injury without any apparent radiological abnormality (SCIWORA) and therefore the cervical spine cannot be cleared until neurological examination is normal even in the presence of normal radiological imaging. Therefore, it is important to immobilise the neck with a cervical collar, spinal board and sandbags on either side of the neck (the Ambulance Service personnel are trained to apply, from the initial scene). Controlled 'log rolling' (with three or four persons according to age) under the orders of the leader who stabilises head and neck, for any examination or procedure at the back, will minimise the risk of iatrogenic cord/nerve injury. It should be noted that any agitated child who struggles should not be head-blocked or sandbagged as the risk of the body struggling against a fixed head may increase the chances of a spinal cord injury.

Blood loss can be considerable due to cut injuries of scalp, especially in neonates and infants, as the blood supply to a unit area of scalp is similar to tongue and heart and considerably greater than many parts of the body. Hypovolaemic shock may result especially in babies, even with a haematoma (scalp, fracture femur) with loss of considerable amount of blood.

Consciousness should be assessed by GCS or quickly with AVPU scale. GCS of less than 14 indicates a serious problem, and head injury should be considered if the mechanism of injury is suspicious. Pupils are windows of the brain. Size, reaction, equality are under the control of sympathetic and parasympathetic fibres (in Oculomotor nerve). Alteration (Hutchinson's pupils) indicates intracranial compression and the side of the problem clinically, though CT scan is required to confirm and for further management.

If a significant brain injury has occurred that is surgically remedial then the patient should be intubated and ventilated and nursed in a head-up position. If there are signs of raised intracranial pressure, a dose of mannitol may be given whilst awaiting surgical decompression.

**Key Learning Points**

- ➔ Airway and cervical spine control take precedent in the trauma or head injured patient.
- ➔ ABC should be managed as normal to ensure adequate oxygenation and circulation to the injured brain.
- ➔ If GCS < 8 then involve anaesthetist or intensivist, and intubate and ventilate.
- ➔ Have a low threshold for CT brain imaging.
- ➔ Involve neurosurgeons early.

**Chest Injuries**

*Pneumo/haemothorax:* Acute respiratory distress developing after chest trauma can occur quickly due to the accumulation of air or blood in the pleural space with resulting acute compression of the lung(s). The child may become cyanosed, tachypnoeic, and demonstrate significant intercostal and subcostal recession. The injured side of the chest may have reduced movement on inspection and palpation, and reduced air entry or disparity of air entry on auscultation. Clinical findings are similar to both conditions except resonant or dull for percussion for air or blood trapped in the pleural cavity respectively. Due to the time taken to arrange for X-ray studies and imminent danger of death, an emergency needle thoracocentesis should be done immediately when the diagnosis of tension pneumothorax is considered. It is difficult to feel the menubriosternal angle or the second rib in children, but even in the most obese child, it is always easy to feel the lower border of the ipsilateral clavicle (Figure 30.6) (NT) and a needle with cannula should be introduced below the midpoint of the clavicle until a 'hissing noise' of air heard allowing a tension pneumothorax to be decompressed. This should be followed up with an urgent chest drain and underwater seal.

Intercostal drainage should be performed if acute lung compression is due to blood in the pleural cavity (haemothorax). Nipple line in children is an easy landmark for incision in the midaxillary line of the chest and the intercostal drainage tube should be inserted only after enlarging the opening in the intercostal space sufficiently enough and feeling with a finger inside. The sharp metal trocar should not be used for introducing the drainage tube lest injury may result to underlying structures (like stomach) if there were to be a ruptured diaphragm. It is wise to have two wide bore needles vascular access before inserting the drainage tube as sudden release of accumulated blood could release the tamponade effect and promote severe bleeding. In acute respiratory distress due to haemopneumothorax, immediate needle thoracocentesis should be done prior to intercostal drainage if there is only one rescuer available. Some practitioners prefer using the Seldinger technique for chest drain insertion.

*Open pneumothorax:* When the pleura from the skin side is cut, the air movement can be bi-directional resulting in a sucking effect on inspiration. Gauze sealed on three sides allows air to escape from the chest and prevents sucking air from the atmosphere, thus preventing tension pneumothorax until a definite action is planned.

*Lung injuries:* Injury to the parenchyma of lung (contusion) should be suspected in any child experiencing blunt or penetrating trauma to the chest. Lung contusion is managed in the same way as any trauma using an ABC approach. Significant lung contusion may cause considerable respiratory distress and may require intubation and mechanical ventilation.

*Rib injuries—flail chest—*When ribs are fractured at two sites of the same ribs, 'paradoxical movements' occur due to movement of the segment in the opposite direction of movement of the chest, resulting in poor oxygenation and ventilation. Endotracheal intubation may be required if ventilation is inadequate.

**Abdominal Injuries**

Emergency laparotomy is indicated when a hollow viscus, such as the intestine, is perforated. A plain lateral decubitus abdominal X-ray in the supine position is often enough to recognise free intraperitoneal gas. In children with intra-abdominal bleeding, conservative management is frequently satisfactory if the patient is otherwise haemodynamically stable. Unlike adults, when bleeding from a solid viscera such as the liver or spleen is suspected, peritoneal tapping or lavage is not usually performed in children. Abdominal ultrasound (US) followed by abdominal CT, if necessary, are the imaging modalities of choice. In general, very few children will require surgical exploration if the patient has responded satisfactorily to initial resuscitation. Emergency splenectomy is a rare procedure in modern trauma care in children. Renal US and CT may help to decide further management of renal injuries.

**Pelvic Injuries**

Run-over injuries typically result in pelvic injuries and genitourinary and other hollow visceral injuries may accompany. Immediate management is on general principles of standard resuscitation. Urethral catheterisation should be performed only after discussion with the surgical team. Stabilisation with sandbags on either side of pelvis is useful till orthopaedic team takes over the management.

**Limb Injuries**

Blood loss can be considerable for long bone injuries and circulation should be taken care of once A and B are satisfactory. Emergency action is required for neurovascular compromise in conditions like angulated or displaced



fractures, compound fractures and compartment syndromes. Immediate manipulation and reduction may restore blood supply, but exploration or adequate incisional release for compartment syndrome should not be delayed if there is no adequate improvement. When delay is anticipated to gain access to operation theatre, incisions deep enough to release acute compression should be done in the emergency room. Immobilisation and parental analgesia and/or nerve blocks (e.g. femoral nerve block for fracture femur) result in comfort for the child.

#### Key Learning Points

- ➔ The general approach to trauma follows the ABC approach.
- ➔ Tension pneumothorax should be managed with immediate needle thoracocentesis—do not wait for radiological confirmation.
- ➔ Small volumes of blood loss may result in significant haemodynamic compromise.
- ➔ Abdominal ultrasound followed by CT abdomen are the imaging modalities of choice in abdominal trauma.

## Thermal Injuries

Children up to 4 years of age represent 20% of burns patients. Most of these injuries are scalds. Risk factors for mortality are burn area greater than 40% body surface area and the presence of inhalational injuries. Following a burn injury both local and systemic reactions occur with the release of cytokines and other inflammatory mediators from the burn site. This can result in a systemic inflammatory response, particularly in burns greater than 20–30% body surface area. The systemic inflammatory response is similar to that seen in other critical illnesses, such as sepsis, and can result in capillary leak, myocardial depression, hypotension and reduced tissue perfusion, acute lung injury and impaired immune function.

Burns should be treated as any multitrauma with an ABC approach. It is important to remember that a burn is often accompanied by other injuries and a formal primary and secondary survey approach is essential. The size of the burn is best assessed in relation to body surface area. In children, the most accurate method to assess the burn area is by using a chart such as the Lund and Browder chart. Other methods such as ‘the rule of nines’ tend not to be accurate in children.

### Airway

Inhalation of hot gases can result in airway swelling and compromise breathing. Any suspicion that the airway may be compromised should lead to prompt intubation to protect the airway rather than allowing hypoxia to intervene.

### Breathing

Burns can affect the lower airways in a number of ways. Smoke inhalation can result in bronchospasm and acute lung injury. Burns to the chest can result in a restrictive lung defect. Carbon monoxide inhalation can result in hypoxia. Pulse oximetry cannot differentiate between oxyhaemoglobin and carboxyhaemoglobin and may falsely reassure. Blood gas analysis is important to assess carboxyhaemoglobin levels and reveal a low pO<sub>2</sub>. High flow oxygen is required to displace carboxyhaemoglobin. Carboxyhaemoglobin levels less than 7% are generally well-tolerated, levels greater than 15% are serious and levels greater than 20% require intubation and ventilation.

### Circulation

Fluid management is critical as significant fluid losses occur and must be replaced to maintain adequate tissue perfusion. A number of fluid resuscitation regimes exist to guide therapy. One of the most frequently used regimes is known as the Modified Parkland Formula.

$$\text{Volume of fluid to be infused} = (\text{Percentage of burn} \times \text{weight in kg} \times 4\text{ml}) + \text{standard maintenance fluid}$$

- Half the resuscitation fluid should be given in the first 8 hours since the time of burn and 50% in the next 16 hours.
- The choice of fluid to be infused should be an isotonic crystalloid such as 0.9% saline or Ringer’s Lactate.

#### Key Learning Points

- ➔ Approach a major burn as a multitrauma using the ABC approach.
- ➔ Fluid resuscitation is an essential part of burns resuscitation.

## Non-Accidental Injury

When the history is not consistent with duration and/or identified injuries or there is significant delay in presentation, non-accidental injuries should be suspected and investigated. The possibility of child sexual abuse should be considered when a child is presented with genital and/or anal injuries.

## Major Incidents

The hospital should have a well worked-out plan to deal with several children presenting at the same time, due to a disaster, such as a collapsed school building, drowning in floods, food poisoning or terrorist attack. Resources—manpower, equipments and materials—should be mobilised fast to the scene and all attendants are made aware of their duties and responsibilities. It is important that clear lines of leadership and responsibility are identified to ensure the best outcomes and maximise smooth running of the department during the incident.

## Transport

Quality rather than speed of transport is beneficial to the child with serious problems. Problems due to A, B, C, D deficits should be corrected or stabilised (including cervical collar and sandbags if required) and only then the child should be transported to ward or ICU or HDU or from hospital to hospital. Appropriate staff who could manage airway, drips, and monitors should accompany the child. All documentation, laboratory results, blood samples, medication, observation charts, X-rays should be transported with the child and the accompanying person should have the complete knowledge about the child and management since arrival in the department, for handing over. Whether parents should accompany the child, depends upon the policy of the hospital.

## REFERENCES

1. Biarent D, Bingham R, Eich C, et al. European Resuscitation Council Guidelines for Resuscitation 2010, Section 6. Paediatric Life Support. *Resuscitation* 2010;81:1364-88.
2. Kleinman ME, de Caen AR, Chameides L, et al. Pediatric Basic and Advanced Life Support: 2010 International Consensus on Cardiopulmonary Resuscitation and Emergency Cardiovascular Care Science with Treatment Recommendations. *Pediatrics* 2010;126:e1261-318. <http://www.pediatrics.org/cgi/content/full/126/5/e1261>.
3. Advance Paediatric Life Support—Practical Approach, 4th edition. London: BMJ Books; 2005.
4. European Life Support Course Manual, 1st edition. Paediatric Resuscitation Training Office, London. 2004.
5. Surviving sepsis Campaign: International guidelines for the management of severe sepsis and septic shock. 2008;36(1):296-327.
6. Dunger DB, Sperling MA, Acerini CL, et al. ESPE/LWPES consensus statement on diabetic ketoacidosis in children and adolescents. *Arch Dis Child*. 2004;89:188-94.
7. Wolfsdorf J. Diabetic Ketoacidosis. International Society for Paediatric and Adolescent Diabetes (ISPAD) Clinical Practice Consensus Guidelines. 2006-2007. *Paediatric Diabetes*. 2007;8:28-42.
8. Head injury. Triage, assessment, investigation and early management of head injury in infants, children and adults. NICE Clinical Guideline 56. 2007 ([www.nice.org.uk](http://www.nice.org.uk)).

# Disorders of Emotion and Behaviour

# 31

## AN INTRODUCTION TO CHILD AND ADOLESCENT PSYCHIATRY

Knowledge of the emotional processes of child development within a family, social and cultural context is essential in paediatric practice. These factors have a primacy in this chapter that may differ in many ways from others in this book. The disturbances discussed are generally not based upon easily defined "organic disease". Although, advances in brain scanning and neurochemistry are becoming more relevant, it is only in a minority of these disorders that laboratory investigations yield useful information. While there is a scientific basis to the measurement of symptoms like depression and there are real advances in quantifying parameters of family and social disturbance, the questionnaires or rating scales used may appear less objective than most clinical investigations. In organic disease, there is usually a primary cause such as an infective agent or a mutant gene. In psychological disorders, there is interplay of heredity and environment. Interaction within a culture, between the patient, the family and the school, contributes to the clinical presentation. When a diagnostic formulation is reached, although there is a good evidence base for some treatments, the management of disorder often varies in the hands of different physicians or psychiatrists and some factors are beyond the reach of medical intervention. The wide range of knowledge that contributes to an understanding of emotional and cognitive development goes beyond the scope of this chapter. Some discussion of development is given in the context of an overview of the mental health problems and psychiatric disorders that may present in paediatric practice.

There are difficulties in making a diagnosis of a behavioural/emotional disorder using the usual medical model. Diagnosis in medicine depends partly on a collection of symptoms and physical signs fitting into a pattern that is recognised, but the quality of diagnosis improves when the aetiology can be proved. For example, there may be

disagreement about a pain of acute onset in the left upper abdomen or lower chest where a patient may be in a state of collapse. One may vote for a myocardial infarct and another may claim an exacerbation of a peptic ulcer. Once the abdomen is examined and the electrocardiogram (ECG) done, opposing views will be reconciled. With emotional and behavioural difficulties, it is often difficult to get further than the grouping of signs and symptoms to make a diagnosis that does not generally include an assumption of causation.

Some attempt to deal with this complexity is found in classification systems using different axes for different aspects of a presentation such as the ICD-10 Multi-axial Classification. The first axis in ICD-10 is generally related to the presenting symptoms, e.g. encopresis or hyperkinesia. The second axis offers a range of specific developmental delays, e.g. reading retardation, developmental speech/language disorder. Axis third deals with grades of generalised learning disability, labelled as "mental retardation". Axis fourth labels any associated physical disorder in the child, e.g. asthma or epilepsy. Axis fifth lists categories of psychosocial difficulty, including mental disturbances in other family members, discordant intrafamilial relationships, inadequate or inconsistent parental control and familial over-involvement. This axis also includes social transplantation, stresses in school or work environment and other social problems including persecution or discrimination. A sixth axis enables a rating to be made for the degree of disability caused. It is only when all of these axes have been accounted for that a meaningful diagnostic formulation is produced. The skill of the clinician lies in deciding which factors are amenable to change.

While more severe disorders may require the involvement of a child psychiatrist, many can be dealt with by a family doctor or paediatrician. Often problems presenting at clinics in the United Kingdom relate to normal stages of child development, which are ill understood by over-anxious or depressed parents. More severe and intractable symptoms

may require a more detailed look at why a parent is finding the situation so difficult, and this may involve referral to a specialist service. A parent, who is angry, distressed or of limited ability, may be unable to take in and implement "good advice" until they see that the advisor has understood their difficulties. This process of listening and building-up an understanding of a child's problems in the family context requires inter-personal skills more than medical qualification.

The complexity of presentations to specialist child and adolescent mental health service (CAMHS) clinics requires a range of approaches to understand them fully. The child and adolescent mental health team usually includes psychiatrically trained nurses, psychiatrists and psychologists and may include occupational therapists, social workers, teachers, child psychotherapists, speech and language therapists and dietitians.

The style of taking the initial history is important in making the shift from the child's presenting symptom to finding out what has actually gone wrong in the family. According to the age of the child they may be seen on their own or with parents/carers, but the adult, who has usually initiated the consultation will require time to express their concern. It is important to begin with clarity about the reasons for consultation and the approach to be taken. Sometimes youngsters have been threatened with the clinic as a response to bad behaviour; they may sit in trepidation awaiting some imagined painful procedure. A child will usually talk readily about his or her interests, friends, school and relationships at home. A more direct discussion of the child's difficulties may be achieved once a shared understanding is established between interviewer and patient.

An attitude of non-judgemental empathy will often enable a child or parent to move from describing the complaint to feelings of despair and anger and then perhaps how unhelpful other members of the family can be. For example, it is not uncommon for a parent of a child with unexplained pain to move on to their own feelings of hopelessness and depression. At the end of half an hour or so, there may be tears, perhaps about marital difficulties. Although the first part of the initial interview can be time-consuming, it may save hours later on. Having allowed this time, the interviewer may ask a wide range of questions, perhaps including details of the child's eating, problems with elimination, pain, levels of activity, details about temperament and relationships, anti-social behaviour, sexual difficulties, episodic disorders and school progress. The usual run through of systems, cardiovascular, respiratory, gastrointestinal, neurological and urogenital are included as appropriate. The personal history pays particular attention to pregnancy, birth and post-natal period, as well as details of personal and social development and the relationship between child and parents during these stages. The family and social history may take more than

one interview to complete. It is important to know about the parents or the child's carers and also to obtain details about grandparents. Information about cultural factors, the parents' childhood experiences, social values and models from families of origin, leads to an understanding of the child's problem within the extended family context. Social inquiry includes details of peer group, education, housing, neighbourhood and finance. The potential impact of drug and alcohol use by the patient or family members in the recent past and also during pregnancy should be explored.

Apart from any physical examination determined by the complaint, it is important to assess the child's emotional state. One notes the child's appearance, communication, mood and self-esteem. The content and nature of the child's free play or creative behaviour during the assessment may be informative. More detailed approaches to observation may be indicated, for example one might make a modified adult style mental state examination or use structured observations, for example looking at behaviours suggestive of hyperactivity in the classroom.

Psychopathology in youngsters is often heightened by family conflict. Adult disharmony leads to inconsistent methods of discipline, which predispose to behavioural difficulty in the children. Children and adolescents can so easily be blamed or blame themselves for one or other parent's unhappiness. This can lead to anxiety and depression, school phobia and other psychogenic symptoms. As there are so often difficulties in family relationships even when there is an obvious physical component to the disorder; some CAMHS clinics begin with a family assessment. In this situation, all members of the family living at home are invited to a first appointment. The therapist joins the family, occupying one of a circle of easy chairs. The initial explanation involves an acceptance that the problem with the child or adolescent involves all members of the family. The aim is to help the family discover where the difficulties are so that, with the therapist, they can plan the changes needed to bring about a resolution. While family therapy techniques require special training, it is worth bearing in mind that involving more than just one parent in the interview can often yield here and now information about the family's style of communication and the degree of mutual support available.

To complete an assessment, consent may be obtained to seek information from third parties such as teachers or social workers. When all this is drawn together a multi-axial classification can be completed. This should lead to a formulation that summarises the various factors leading to the child's presentation and leads to a plan of action. There may be a need for further assessment that could be medical, neurodevelopmental, psychometric, psychotherapeutic and often involves further exploration of family relationships.

A range of treatment approaches exists. Some are focused upon the child, such as pharmacotherapy and various forms of psychological therapy, of which cognitive behavioural therapy has the strongest evidence base. Family interventions are common and the power of group based therapeutic interventions, especially in adolescence is well-recognised. Schools provide an opportunity for environmental management and specific supports for learning. Community projects are often geared to prevention and early intervention in support of parenting. At the other extreme, in-patient care and intensive out-reach or day services are used in the most severe and complex disorders.

There are social benefits arising from effective mental health interventions in childhood. Not only may cycles of abuse and parental failure be broken down but also there is a prospect of reducing the progression of childhood disturbance into adult disorder. For example, vulnerable children who present with anti-social behaviour may benefit from the collaboration of health and social agencies in a co-ordinated approach to reducing the risk of adult offending.

### PROBLEMS IN EARLY CHILDHOOD

Most people readily understand the bodily changes as children grow. The changes involved in intellectual and emotional development are less easily comprehended. The development of speech, with the skills of language amongst the complex tasks of social communication is a crucial factor in further learning and social interaction. A massive amount of learning takes place during the toddler years. By the time a normal child enters school he has a good grasp of language that underpins the development of social and emotional behaviour.

Adverse environmental circumstances can retard physical growth and cause children to function intellectually below their potential, but the greatest effects of adverse family relationships and social difficulties are generally upon children's feelings and behaviour. The first year of life or infancy is largely to do with the relationship between the caring adult or adults and the child. The infant needs to be kept warm, fed, clean, cuddled and interacted with. The beginning of shaping up vocalisation into speech involves eye-to-eye contact and social communication grows. A child should begin to feel secure in the knowledge of adult care and understanding of his or her needs. Important problems can arise during early development. The initial attachment of infant and caregiver may be adversely affected by maternal depression or illness in the child requiring long hospitalisation.

Pre-school behaviour problems usually start during the next phase of emotional development. During this phase children may appear defiant and demanding. The toddler

thinks as if he/she is at the centre of everything and there is little awareness of the needs of others. The toddler's timescale is poorly developed and there is little ability to tolerate frustration, to do it later, or wait until tomorrow. Temper tantrums are common and may be intolerable for parents who lack awareness of what is normal in this developmental stage.

A baby can be put away in a cot for periods of time but a toddler is mobile. Rapid cognitive development makes for a huge interest in exploring an environment that was previously inaccessible. Under these developmental conditions it is often a full-time job for the mother to keep the toddler safe and involved in learning social skills. Tables are pulled over, taps left running and electrical sockets interfered with. As speech develops there can be constant unanswerable questions, loud singing or protests if visitors or siblings interfere with activities or social discourse with the parent. Where the parent is feeling below par, perhaps living in a high flat where there is nowhere to go out to play or in an area which is clearly unsafe for youngsters to go out alone, the tension mounts. Where 2 or 3 youngsters are vying for attention in a family, the parent may be reduced to shouting, smacking or ignoring behaviour that requires attention or correction. In such circumstances, social programmes and parent support groups may be effective interventions. Although early childhood problems are often understandable in this way, a significant proportion of children presenting at this age will have temperamental characteristics or developmental disorders contributing to their difficulties.

Discipline should be firm, clear and consistent but also reasonable. It should relate to the child's developmental stage and understanding. A child will learn most easily when they feel secure with their parent or carer. Prompt positive reinforcement with respect, praise and love is the best way to modify behaviour. Punishment is not recommended but if rewarding experiences are to be withdrawn this should be carefully considered and quickly carried through to emphasise cause and effect. The more frequent the punishment the less its effect and too often threats are postponed until behaviour causes damage or an accident. Most importantly parents must not be split, with one colluding with behaviour, which the other is trying to correct.

A number of problems arise with failures of discipline. These include; feeding problems, temper tantrums, difficulty going to sleep and battles over toilet training. Sometimes a child has particular difficulties that challenge the most competent parent, but by the time professional help is sought, parents have usually become quite inconsistent in their management of the problem. Parents will often claim to have "tried everything". Similar themes are found in most discipline problems, but each type has particular features.

**Case Study**

A child of 4-year-old who will not go to sleep is told a story. Then he calls out, a reprimand is given and a testing cry tinged with uncertainty follows. Perhaps he will be given a drink and put back to bed. Opportunistically he cries again only to be given a severe telling-off by a mother who is beginning to be irate and exhausted. She says that she will go away if he is not good, so he cries again. Eventually after further loss of temper the mother feels guilty and upset that the child's shrieking will invite criticism. She brings the child back into the living area to watch the television. Another attempt is made to go to bed and the crying starts again. Night after night the situation worsens. Mother confides that she once put a pillow over the child's head momentarily and then became overwhelmed with guilt and took the child to bed with her.

A 2-year-old with food fads raises parental anxiety by refusing to eat and thus manipulates the situation so that their favourite baked beans or biscuits have to be eaten for breakfast, lunch and tea. All kinds of bribes, punishments and ultimata are given while the toddler resolutely refuses to comply with normal meals. There is inconsistency between anxiety that the child may become ill or even not survive and the adults' temper loss with sometimes severe smackings and episodes of rejection.

Distraught parents require a sympathetic ear with some exploration of why this stage of development is difficult. Reassurance is important (for example, a parent may fear that the child will grow up delinquent or anorexic). Where possible, the principles of appropriate discipline should be reinforced and some parents need referral on to social services for support and guidance.

**WORKING WITH PHYSICALLY ILL CHILDREN**

If a child becomes unwell for significant periods of time the task is not only to get them well but also to enable them achieve their developmental potential. Children grow in three ways: (1) they become physically taller, (2) heavier and (3) sexually mature; they increase in cognitive abilities; and they achieve social and emotional development. As children become more mature they are better able to handle extremes of feeling and to give and take in inter-personal relationships. The tasks of adolescence involve issues of separation and dependency as well as coping with adult values and sexual maturation.

The work of CAMHS involves the pathology of inter-personal relationships and any disability, inborn or acquired, will increase the risk of harmful attitudes in other family members, e.g. over-protection and rejection. Sometimes a parent's need to overindulge the child is based on (usually) irrational feelings of guilt about their disorder. It is also important to note that hospitals, like families, sometimes contain "sick systems" where anxieties, frustrations and inter-

personal difficulties of doctors, nurses and other therapists damage the effectiveness of professional networks.

Physical illnesses make children more vulnerable to psychological disorder and this effect is magnified in diseases affecting the brain such as epilepsy. Technical advances in treatment subject children to stressful situations. Family disruption with frequent hospital attendances, transport problems, the effects of boredom, pain and tiredness take their toll. Such stresses are particularly damaging for vulnerable families. Pre-school children do not always understand why they are being hurt or why their parents sometimes have to leave when they are scared and in pain. The sequence of angry protest followed by despair and then emotional detachment from parents is well recognised in association with hospitalisation of younger children without their parents. Children's hospitals encourage parents to stay with their children, but mothers sometimes have to go home to look after the rest of the family. This kind of separation can have harmful, albeit temporary, effects. Thus, a young child perplexed when the mother visited, turned to run towards the mother, halted and then ran to the comfort of the ward sister.

A child can often accept handicaps or painful treatments as long as all is explained honestly and at a level that can be understood. Anxiety increases if the parents do not appear to be at ease with the situation or if the child is told untruths or let down. It is helpful to listen to the child's worries and questions and then discuss with the parents how the questions should be answered in an understandable way. Children think in concrete practical terms and can be confused about illness and the possibility of dying. Death is seen as a reversible phenomenon by the very young. While it may well be unnecessary to trouble a child with details of a poor prognosis it is not helpful to ignore a child's concerns. When distressed children are told not to be silly or "let's see a smile", the anxieties, which are worrying them, are deflected and not dealt with.

**Case Study**

One young child almost died from a deliberate overdose. A much-loved relative had died and it appeared the only way to visit him was to go to heaven and the only way to heaven was to become dead. Having been told that medicine cupboard contained poison he carefully consumed some of its contents and waited for a "sort of aeroplane ride" to get to heaven. When it was explained that there was no way back and he would not see his friends and relatives again, he decided that he had been unwise.

**Coping**

There are predictable patterns in coping with bad news, for example that mild malaise is actually renal failure and a transplant is required, or that "anaemia" is really a cancer of the blood. Denial is a common mental mechanism, characterised

by disbelief. This may be helpful at times but sometimes its effect is that potentially successful treatment regimes are not adhered to, particularly in adolescence. Thus, denial becomes unhelpful when insulin injections penetrate the arm of the settee rather than the skin. Reaction formation occurs where there is opposition to the underlying feeling and there may be pressure on an ill child to achieve more than they are easily able to do. For example, small vulnerable children may need to be big and tough. Others may regress to infantile and dependent behaviour. Some youngsters develop rituals before treatment regimes and others dispel their anxiety in fantasy. In children's hospitals, there are a lot of bandaged teddies. Adolescents sometimes identify with medical staff by taking an intellectualised interest in their disorder.

All of these defence mechanisms can be helpful as well as destructive and if these defences fail too rapidly the youngster may be overcome with anxiety, become severely depressed or on occasion curl up in a foetal position and withdraw from treatment or refuse to eat. Guilt is anger turned inwards with soul-searching as to how the disease or accident could have been avoided. Sometimes this leads parents to become depressed with an escalation of guilt and sometimes-morbid thoughts with sleep and appetite disturbance. The marital situation can deteriorate and where one parent spends a long-time in hospital with the child, the other may be marginalised. Exhaustion and disruption of routine causes irritability and sometimes disagreements about the way the child is managed. The siblings are also compromised in that the parents do not always meet their basic emotional needs.

#### Case Study

A young child with a urinary tract infection was reassured that he would not need dialysis like his sister. In a temper, he slammed out of the room, saying, "Does that mean I am not getting the machine as well then".

The predicament of a sick child affects the whole family and all should benefit from a realistic acceptance of the disorder so that the child is neither over-protected nor expected to do more than he is able. To achieve such adjustment it helps to see both parents together. If the same person sees the parents on a number of occasions it is possible to check out what they took away from previous interviews. However, bad the reality, a child's fantasy may be worse. In general, a child's questions should be answered directly, honestly and in a way that is understandable. School attainments are important as long-term disorders can interrupt education, which is a major determinant of adult outcome in chronic childhood disease. Sick children need discipline as well as care, which can be difficult for any adult. A team approach ensures that communication is strong enough to avoid anxious parents inadvertently setting one professional up against another.

Sometimes anxious parents make staff feel ill at ease but parents should be given their place. Close relationships may develop with some staff. The work is multidisciplinary and all members of the team should feel appropriately useful and valued. Work will be stressful especially when children do not recover, but morale is helped by regular discussion both case centred and more informally so that anxieties are shared and treatment goals sustained.

## EMOTIONAL DISORDERS AND MEDICALLY UNEXPLAINED SYMPTOMS

Children express themselves in physical as well as psychological language and it is helpful to understand the different terms used in such presentations. Various terms may be found in the literature and the confusion of language reflects the complexity of the topic.

*Neurosis* is a term used to describe predominantly psychiatric disorders that nevertheless may cause a number of worrying and apparently "physical" symptoms including abdominal pain, headaches and limb pains, which sometimes can be severe and disabling. Thus, appetite disturbance, nausea and vomiting can be symptoms of anxiety.

*Somatoform disorders* include a range of stress-linked physical symptoms that may be the main presentation of emotional disturbance. For example, somatoform abdominal pain can be severe and although there is no real guarding or tenderness, some children appear exquisitely tender or find it difficult to relax to have their abdomens palpated. It is surprising how such pain can become localised to the right iliac fossa or epigastrium when various doctors have made repeated examinations querying acute appendicitis or peptic ulceration.

*Psychosomatic disorder* is a term sometimes used in illnesses with a known organic causation, where there are changes in tissue structure or function, but where the disorder or exacerbations of the disorder are partly or mainly induced by stress. A number of illnesses can be included in this category, for example some cases of asthma, migraine, skin disorders or bowel problems.

*Cyclical vomiting syndrome*, where attacks of prostrating vomiting occasionally needing intravenous fluids can last for 1 or 2 days, is a complex example, linked to migraine. As the child gets older, visual disturbance, photophobia and pulsating headache become more apparent and the vomiting less obvious. In some cases, the episodes are triggered or maintained by stress. Children with migraine disorders are often normal between episodes and these are best regarded as organic conditions, possibly with a psychosomatic element but they are not neurotic disorders.

*Conversion disorders* have been thought to involve the psychological mechanism of dissociation whereby the patient is not connecting emotions with experience and is unaware that the symptom is other than organic. Conversion symptoms include some disorders of movement, apparent paralysis of limbs and psychological seizures. Children presenting with these disorders may be in some kind of an emotional trap or predicament. Where conversion is suspected one should look at all aspects of the child's life situation and find out what purpose the symptom is serving or how it is protecting the child from whatever happens if the symptom goes away. Episodes of vomiting may keep together parents who are on the verge of separating. A girl's sore tummy may be stopping her highly esteemed father from trying to have sexual intercourse with her. The astute clinician sometimes sees something symbolic in the presenting complaint, as it is not just chance that certain symptoms are unconsciously selected.

"*Medically unexplained symptom*" is a description that helps to avoid problems in categorising such disorders. There are several pitfalls in attempts to distinguish the origin of such symptoms. Some symptoms can be frankly goal directed with conscious awareness of the gain involved, but the diagnosis of conversion disorder implies an element of dissociation or unawareness. A diagnosis of conversion requires a satisfactory formulation of the child's difficulty, and is confirmed when attempts to ameliorate that situation bring about a considerable improvement in the disorder. Children and families may resist a conversion diagnosis for many reasons and many find it hard to understand psychosomatic causation. Often there is dual pathology, e.g. psychological seizures are often found in children with epilepsy. Some cases of so-called psychogenic disorder turn out to have an organic basis when followed up. Unusual presentations of common disorder and sometimes extremely unusual disorders can appear within the course of time. For example, peptic ulcers are a more common cause of intermittent abdominal pain than perhaps one would expect and very rarely, peculiar panic attacks are due to cerebral tumours. Where there is doubt, a decision about diagnosis is best made using both paediatric and psychiatric expertise with a capacity for joint review when there is continuing uncertainty. Where there is no organic disease identified it is possible to make progress through psychological interventions geared to the individual presentation without requiring precision on the mechanism of symptom causation.

## Emotional Disorders

*Anxiety* and *depression* often co-exist and may be missed when they present in children, especially when expressed through somatic symptoms. More psychological signs of

emotional disorder include sleep difficulties with anxious or depressing thoughts keeping the child awake or preventing him/her going to bed. Early waking which is usually regarded as a symptom of endogenous depression can also occur, especially in older children. Poor concentration is frequently present and may have gone unnoticed in school, as children with emotional disorders do not usually present a behavioural problem in the classroom. Tearfulness, oversensitivity, agitation and irritability are common. Anxious toddlers and young children are unsettled and on the go and may be thought to be hyperkinetic. Where depression predominates the youngster will admit to feeling bad and guilty and sometimes overwhelming feelings of wretchedness can be associated with stealing, tearing up promising work, being unable to accept praise and wanting to die. In pre-school and young primary children, the ultimate depressive thought seems to be separation and abandonment from the parents or those looking after them. Emotional disorders occur in at least 2% of the population of late primary school children. Feelings of guilt leading to suicidal ideas have to be checked out in the older primary school child and certainly in the adolescent. One might ask, "Do you sometimes feel so bad or unhappy that you would like to run away from home or have a bad accident or die". A reply in the affirmative must be taken seriously and it is a myth that children who talk about harming themselves would not do so.

*Self-harming behaviour* and *attempted suicide* are common in adolescent populations although socio-cultural factors lead to varying prevalence across communities. Such presentations require urgent and careful attention to the range of individual and family factors that may have preceded the event. It is important to look for treatable disorders such as depression. Specific interventions may reduce the risk of recurrence and address the underlying difficulties revealed in the crisis.

*Phobic anxiety* presents where there is a specific anxiety in certain situations, e.g. thunderstorms, fear of dogs and being upset by insects. Often these fears are not generalised into other situations and the youngsters may in other ways be quite emotionally robust. Specific psychological intervention with the child can be most helpful. Phobias in children may be learnt from a parent, friend or relative. This is not always volunteered until asked about during a detailed history taking, but it is then useful to try and help the affected parents to try and overcome their own difficulties.

*Obsessive/compulsive disorder* is characterised by feelings of compulsion to carry out some action or repeatedly dwell on an idea that is difficult to resist. This leads to repetitive rituals, e.g. hand washing which has to be performed time and time again, despite the child and the parent wishing this not to happen. Obsessive/compulsive disorders are more common in children with neurodevelopmental impairments



and there is a genetic contribution to aetiology. In younger children, however, rituals can sometimes be a way of reducing anxiety, which may have its roots in disturbed family relationships, schoolwork that is too hard, or pressure from friends. Toddlers and young children love repetitive games and songs. They can exhibit ritualistic behaviour as part of normal development, e.g. needing to go round every lamp-post twice. These pre-occupations are usually short-lived unless re-enforced by an anxious parent, nevertheless it is important to remember that obsessive compulsive disorders are not so rare and as they are treatable conditions it is important to take parental concerns seriously.

*School phobia* and *school refusal* are terms used for children who develop emotional or unexplained physical symptoms in the morning before school. The symptoms ameliorate either when they have been at school for a while or when the decision is made that they are too ill to attend. Often symptoms are not due to a true phobia of school, but are caused by separation anxiety about leaving home and parents. Some school phobic children are depressed. Such children are often good achievers and although they may try to go to school, symptoms occur to prevent this happening. Their parent or parents are much in evidence, worrying about the child's pains, vomiting, or else being angry that he/she has failed to leave the home for school. These patterns of behaviour are totally different from truancy.

*Aetiology* of childhood emotional disorder is often multifactorial and is frequently bound up with family relationships that may include elements that are genetically inherited. In some cases, the mother of the affected child is frankly depressed or very anxious. In the seclusion of a one-to-one interview, mothers will often begin to cry and disclose morbid ideas. Doctors are thought to be missing a fatal disorder in the child and depressive thoughts become unwittingly projected onto the youngster. In school phobia, the parent feels worn out by the daily decision whether to send the child to school after being reassured he is physically well. Sometimes when asked, "Have you ever felt that you could not go any longer?" Mothers will disclose feelings of total hopelessness and frustration. If the child is asked if he/she worries that their illness upsets the mother, they may burst into tears. On questioning it emerges that he/she is worried that mother cannot cope. Occasionally, the mother has said she can go on no longer and she may leave home or try to "end it all". Separation anxiety is then only too real, the child is scared to allow the depressed parent out of their sight, and the parent requires the child to be around to help her get through the day. Frequently there are associated marital problems and the father may resent the over-closeness of the child and his spouse.

Emotional disorders can be triggered or maintained by stresses affecting the child, especially in school or with friends. Bullying is often a hidden problem in schools and stress may also arise if a child with specific learning difficulties is seen as lazy and ridiculed or punished when trying to do his/her best. Losses and separations can trigger depression. Illness or death of an important family member may cause a bereavement reaction in a parent for many months. The parent is reluctant to discuss this and the child patient feels blamed when his carer is irritable and unresponsive.

Many children are resilient and can adjust well to stress but some are more vulnerable due to constitutional factors and past experience. Stress may trigger a range of problems including *adjustment disorders* with conduct and/or emotional symptoms. Extreme stress can lead to *post-traumatic stress disorders* with characteristic avoidance of possible reminders of stress, nightmares and sleep disturbance and some re-experiencing of stress or "flashback" phenomena.

Classical adult presentations of *depressive illness* occur particularly in older children and young people. *Bipolar affective disorder* may have onset in adolescence but great care should be taken in the interpretation of symptoms in making this diagnosis.

A small proportion of children have *mixed conduct and emotional disorder*. These children are often brought up in disorganised, delinquent and socially deprived families with patterns of anti-social behaviour. If they become depressed, the symptoms are more likely to be difficult to contain and control. Children exhibit outbursts of self-destructive behaviour and anger with extreme sadness, guilt and feelings of hopelessness. Sometimes such a youngster will have trouble in trusting adults and needs to be contained and controlled due to the disturbed risk-taking aspects of their behaviour. While it may be difficult to understand such emotional symptoms, some children are so frequently undermined and put down by their parents, teachers and potential friends that they can only see themselves as inadequate and hopeless. Anyone trying to be nice to them feels like a phony. Children often exhibit their feelings in the way they behave. A happy child will be spontaneously bright, but a child who is feeling bad will sometimes be unable to stop itself from doing bad things.

First-line treatment of emotional disorders will generally be psychological and family based for the younger child. In older children and adolescents adult forms of treatment are more likely to be used. There is good evidence for the benefits of individual treatments, particularly cognitive behavioural therapy, which combines behavioural principles with strategies designed to alter thought content. Medication with specific serotonin reuptake inhibitors may be considered. The risks of heightened arousal and increased suicidality

may outweigh the benefits of such antidepressants especially in less severe disorders. Rarely treatment resistance in this group of disorders can lead to complex interventions including in-patient care.

## ELIMINATION DISORDERS

### Enuresis

Enuresis refers to the persistent involuntary or inappropriate voiding of urine. This can occur while the child is asleep (nocturnal) or during the day (diurnal). The disorder may have been lifelong (primary) or come on at a later stage (secondary). It is often useful to think of primary enuresis as a developmental delay, but like secondary enuresis it may have many physical causes. Nocturnal enuresis is a commonly occurring disorder that affects approximately 10% of United Kingdom children at the age of 5 and 5% at the age of 10 with 1% or 2% continuing to wet throughout the teens. There is frequently a family history and it is usually a mono-symptom with emotional factors being secondary. There is an increased incidence of wetting amongst children with child psychiatric problems, but no correlation with any specific emotional disorder. Enuresis more often occurs in children in poor social circumstances where early training has not been established. Some children have had disturbing life events at the time when night-time bladder control should be acquired and the symptom is more frequent in children with other developmental delays and with encopresis. Nocturnal enuresis is not primarily a child psychiatric problem and is generally managed by families with primary care support or in specialist nurse led clinics, with referral to CAMHS clinics restricted to cases where more complex problems are suspected. Associated urinary tract problems and other medical problems are unusual but should be borne in mind and investigated as necessary.

The simple technique of uplifting a child when the parents go to bed sometimes solves the problem at a practical level. The use of star charts should be reserved for those children who wish to fill them in. All too often there is an expectation that the star chart will work and when it does not there is loss of face for the child, the parent and the doctor. Where angry feelings underlie the problem the chart will merely emphasise difficulties, which may or may not please the youngster. If the child has regressed the chart will be meaningless. The chart can imply that the child has voluntary control; to be dry is "good" and to have accidents is "bad". Some children who wet are quite depressed and for them it feels appropriate to be smelly, damp and chastised; the chart may reinforce these feelings.

The best behavioural treatment is the enuresis alarm, designed to wake the child when voiding commences.

Attention to detail is important as false alarms can be caused. If there is no progress after 3 months, it is better to withdraw the apparatus assuming the child is not developmentally ready to benefit.

Antidiuretic hormone, in the form of nasal spray or oral preparations, leads to symptomatic improvement. One should be cautious if there is any renal or cardiac problem. Tricyclic antidepressants are as effective but have side-effects and are very dangerous in overdose. Bed-wetting often recurs when drugs are stopped, unless the child has grown out of the problem during the time of the prescription.

### Encopresis

Faecal soiling without physical cause is known as encopresis, sometimes it is most helpfully understood as a developmental delay. Soiling may be continuous or discontinuous.

*Continuous soiling* occurs where the problem has always been present. Affected children may come from families with low expectation, poor motivation and inconsistent attempts to start toilet training. Such families have other social difficulties and the carer may have a background with poor models of parenting or be depressed and pre-occupied with other problems in the family.

*Discontinuous soilers* may have been satisfactorily trained or may have been especially early trained in bowel control. A way of looking at the mechanisms and family attitudes of children with discontinuous soiling is to look for signs of *regressive behaviour* or an *aggressive toileting situation*.

*Regressive soilers* are usually reacting to stress and anxiety. Stresses arise within the family and may be made worse by the effects of soiling leading to a vicious cycle. Children feel criticised and scapegoated and some have been harshly disciplined when they are soiled. The soiling may not be the only developmental milestone that has slipped back. The child may be clingy, withdrawn and exhibit toddler-like temper tantrums. Such children are often difficult to engage in play and sit dull, poorly motivated and emotionally flat. Discussion about the bowel problem is useless at first as the mental mechanism of regression switches off understanding.

*Aggressive soiling*, the parent may at first describe reasonable attempts to toilet train, but if sufficient interview time is allowed, one becomes aware of considerable tension and anger regarding soiling. All too often a youngster is expected to perform by a harassed mother in a setting where relaxed toilet training cannot occur. The child may respond negatively and, either voluntarily or involuntarily, retains faeces. Megacolon is frequently associated with this situation.

*Megacolon* is a physical disorder that must be suspected in any child with a history of intermittent, runny stools

often with a fusty acrid smell, with overflow incontinence, especially if there is an intermittent history of extremely large bowel evacuations. The condition is frequently chronic with impaction of large faecal masses associated with dilatation of the rectum and colon. The bowel becomes flaccid and unable to pass stools in the normal way. As the situation progresses the child completely loses any sensation of needing to go to the toilet. It is often difficult to weight the physical and emotional maintaining factors. Children with lack of continence are not always treated sympathetically, because adults think the cause is behavioural whereas the child has no bowel control. Occasionally an anal fissure compounds the problem. Often family psychopathology appears secondary to physical problems and careful medical assessment is required. The details of such assessment and treatment are outwith the scope of this chapter. Dietary advice to increase fibre and fluids may be helpful. Laxatives of various kinds are the mainstay of management, but enemata and/or suppositories may be needed and rarely surgical manual evacuation is required.

#### Case Study

A 9-year-old boy, sexually abused as an infant, lived with adoptive parents. His discontinuous soiling had become entrenched and he had developed a megacolon. Attempts at paediatric treatment were complicated by his emotional reactions and adoptive parents feeling of failure. The family benefited from an approach that carefully presented the problem of megacolon in a cartoon form that the child could understand. As the child engaged with therapist and adoptive parents in the task of "beating his problem poo" his adherence to a laxative regime and toileting programme led to slow bowel retraining taking around 6 months.

In encopresis where there is no megacolon and where the child passes a normal consistency stool at regular intervals, there seems little value in using laxatives routinely. Excessive use of laxatives impairs function of a healthy bowel. A behavioural approach with the use of a star chart and simple educative advice may be helpful to a child who has not received basic toilet training. If a chart recognises success, but not failure this reduces false expectations. Positive reinforcement is always more acceptable than a programme that increases the parents anger or discourages the child especially where there is no voluntary bowel control. If possible, the child and family should be brought together as allies with the therapist in tackling the problem of soiling, which is helpfully thought of as a problem that is external to the child and family and nobody's fault. Where the child is under considerable stress, or where there is too much anger for co-operation with treatment, it may be helpful to review wider issues of family relationships. Psychotherapy often in the form of play therapy for the child can be helpful.

Where ongoing psychological treatment for soiling is needed it may be best to delegate physical treatment to a separate paediatric clinic. Therapy is undermined if the therapist plays the dual role of doctor and psychotherapist. A pre-school toddler, who soiled in anger, attacked a Daddy doll during therapy, buried him in the sand and beat the sand down with a shovel. The Mother doll was also given a hard time for sending the Daddy away. After 30 minutes of this distressing anger it would not feel right for the therapist, let alone the child, for the session to be followed by the therapist giving the child an enema.

## BEHAVIOUR DISORDERS

### Attention Deficit Hyperkinetic Disorder

Many people believe that attention deficit hyperkinetic disorder (ADHD) is a straightforward condition manifested by motor restlessness, distractibility, poor concentration, impulsivity and labile mood. The simple explanation of this disorder is caused by brain dysfunction and elegantly responds to Methylphenidate is much too neat and tidy a concept which bears only a limited relationship to the assessment of badly behaved, inappropriately controlled and under-stimulated children who are referred to paediatricians and child psychiatrists. As knowledge of developmental neuro-psychiatry has increased, so the simple story has seen to be flawed. It is important to realise that hyperactivity is not simply a manifestation of brain impairment. It is unlikely that hyperkinesis is a unitary condition and various aetiological theories have been put forward.

Specific learning difficulties not explained by global retardation are common in children with ADHD. Occasionally, ADHD may follow brain damage that is identifiable on scanning. This is a recognised outcome of low birth weight and is found in conditions arising from intrauterine adversity, such as foetal alcohol syndrome. The infant's brain is both vulnerable and plastic with an enormous capacity for function to develop in spite of areas of damage. Such damage may be generalised rather than localised, e.g. by anoxia, so that it is reasonable that some years on the effects of damage will be manifest by impulsivity and labile mood. The parents of children with ADHD have increased rates of alcoholism and sociopathy when compared with the relatives of normal children. Theories of disorders of monoamine neurotransmission are well supported and genetic effects have been robustly demonstrated, but the constitutional basis for this disorder remains unclear. While specific factors in heredity, pregnancy, delivery or neonatal period may correlate with dysfunction; it can be difficult to confirm such links when dealing with individuals.

Food allergy is considered important by some, but additive-free diets are often expensive and difficult to follow. If there is evidence that certain foods upset the child, a dietitian can devise a trial of diet that is sensible, within the grasp of the parent and unlikely to deprive the child of essential nutrition. Sometimes helpful results are obtained, although it is not always clear what is due to support and what is due to diet. It appears reasonable to keep an open mind and carefully accumulate data. While coeliac disease is considered a respectable paediatric diagnosis, the possibility of wheat allergy is often discounted. There is little doubt that some children are irritable and restless when they are itchy with eczema or frustrated by coryza and nasal stuffiness.

Whatever the underlying constitutional disturbance there always needs to be an emphasis on consistent and positive management. Children with ADHD generally struggle in a classroom, often receiving criticism and negative reinforcements, which alienate them from teachers and sometimes classmates. This leads to over-arousal, making distractibility worse and contributing to the development of poor self-esteem. Depressive feelings may further reduce motivation and there may be a defensive reaction "that teacher is always bugging me" or "I am not working for him". It can be difficult to sort out cause and effect when parents appear tired, angry or depressed. As the cycle of events winds up, parents become inconsistent being either inappropriately angry or at other times too negative and exhausted to intervene. Follow-up of children with ADHD shows a high-risk of developing conduct disorder in later childhood and anti-social behaviour and alcoholism in adult life.

Children with ADHD require a treatment plan. This will include advice on their management, often involving the educational psychologist working with the school and sometimes support to the family from a social worker. The neurostimulants, methylphenidate and dexamphetamine are effective with or without a wider treatment programme. Their use can cause appetite impairment and growth retardation, anxiety, sleeplessness and very occasionally psychosis. Where there is social deprivation, others may abuse stimulants. Other medications that can help include atomoxetine, clonidine and antipsychotic drugs. All drugs may have a potential for interactions and side-effects, in particular, antipsychotics present the long-term danger of tardive dyskinesia. There is limited evidence that tricyclic antidepressants may be helpful, although they are not widely used due to a poor balance of risk to benefit. Rarely, it may be useful to consider an admission to a child psychiatric unit to see how hyperkinesia responds to consistent care before embarking on many years of pharmacotherapy.

## Conduct Disorder

Although the management of children with aggressive and destructive behaviour giving rise to social disapproval usually falls to other professionals, doctors are bound to become involved as such problems are common. The incidence of anti-social disorders varies from around 2 to 10% in the mid-childhood years, depending on the kind of population being served.

There are two principal approaches to understanding the learning of social behaviour. First are the well-researched cognitive and behavioural models of social learning where consistent rewards and reprimands and exposure to pro-social attitudes and behaviours are needed to learn appropriate responses. Second, the psychodynamic approach concentrates on the quality of relationship between the child and the parent or authority figure. In both models, difficulties may arise in the family and/or in other areas of community life, especially in school.

Family norms may not be acceptable to society; many delinquent children have fathers and sometimes mothers with a criminal record. Some families issue no clear guidelines and throw their children into confusion by their response to behaviour, being very punitive on occasion and at another time amused when the youngster does something inappropriate. Some families have unclear roles with perhaps the elder sister taking over when the mother is not coping. The impact of personality disorder or substance misuse in the parent or parents must be taken into account with a range of other social factors.

The community can foster anti-social behaviour. Housing may be allocated so that families with social difficulties are housed together in unpopular housing schemes. Their children are exposed to a peer group with high delinquency rates and neighbours potentiate this downward cycle. The culture of a school can make or break a youngster who is not well supported at home. Children with conduct disorder often fall behind in reading and other school attainments; conversely children with learning difficulties have an increased rate of conduct problems. If the child is encouraged and made to feel an important individual in his own right within school, identification with the school system and certain teachers will exert a positive influence. Conversely if the child does not succeed in school he is much more likely to get recognition from other anti-social youngsters. If specific learning difficulties are missed a child who is of average intelligence is labelled as "lazy" or "not trying" in the area of disability. Motivation can fail due to a depressive or angry attitude towards school.

The medical skill lies in identifying conditions within the child that predispose to anti-social difficulties, especially treatable disorders such as ADHD. Children vary in

temperament and parents who have successfully reared one or more "easy" children may find that their methods do not succeed with a more challenging child. Children who are hyperkinetic with poor concentration and sometimes poor co-ordination are difficult to discipline. They easily get discouraged with repeated failure or develop negative ways of opposing those putting pressure upon them. Depression can sometimes give rise to stealing and under functioning as the "I am bad" guilt is sometimes acted out or the object stolen may be held for comfort. Lastly some children with long-term illness or handicap who are feeling vulnerable may need to overreact to show friends and teachers that they are a force to be reckoned with.

Conduct disorder may develop out of *attachment disorders*, where the effects of early emotional deprivation (for example, poor quality institutional care or care by a mentally disordered parent) can lead to profound difficulties in relationships, with striking abnormalities in social contact. Classically such children may be inhibited with "frozen watchfulness" or disinhibited and indiscriminately friendly. There are continuing rages and toddler-like behaviour sometimes for many years even though a child may be in an improved home situation.

#### Case Study

A 13-year-old boy was brought to the clinic by his social worker and his mother. He had been in trouble with gang related offences of violence, theft and possession of street drugs. His father, an aggressive man, had left home 4 years ago and his mother was an alcoholic, unable to give consistent care to her children. He was residing in a children's home but not able to relate well to staff, testing their commitment to him. If he began to feel secure he would do something bad. Thus, if he were moved on it would be on his terms, which he saw as better than being rejected "for no reason". Nevertheless after an incident he hoped to be allowed to stay. Similar testing behaviour occurred in school. Like his father he had specific learning difficulties as yet unappreciated by teachers who focused more on his behaviour. Unable to gain satisfaction in lessons, he found it more rewarding to truant and revelled in his role in the gang.

#### Truancy

This form of school non-attendance is more frequent in underachievers; from families who (rather than being over-involved with the non-attendance as in school refusal, above) are unconcerned or unaware of the situation until the authorities make contact. It is unusual for psychogenic symptoms to be found in truants who frequently go off to join friends in conduct disordered activity.

## EATING DISORDERS

A range of emotional and behavioral disorders lead to abnormal eating in childhood and unusual eating behaviours are commonplace in adolescence. Although eating disorders may be a focus of considerable parental concern, the insidious development of *anorexia nervosa* is still sometimes overlooked.

*Anorexia nervosa* has at its core a morbid fear of fatness and a distorted body image. Weight loss leads to a low body mass index (BMI), pubertal development and growth may be retarded. The disorder sometimes develops from dieting with selective rejection of calorific food. Various tactics to lose weight are displayed, the most dangerous of which is vomiting, sometimes done quietly and with remarkable ease. Bursts of frantic exercise may occur openly or in secret while increasing quantities of laxatives and purgatives may be consumed. Girls develop amenorrhoea and the disorder is typified by bradycardia, hypotension, a growth of fine hair, and increased pigmentation. Sometimes the parotid glands are swollen and the back teeth decayed due to acid reflux from vomiting. Baggy clothes often disguise weight loss. It is only when one has sight of the protruding ribs, scapulae, clavicles and the scaphoid abdomen with prominent iliac crests that the degree of starvation become apparent. Emotional state is adversely affected often with obsessive or depressive and suicidal thoughts. Some youngsters show attention seeking and confrontational behaviour, which may involve the family and therapists, who become fearful for the fate of the patient and also angry with them.

Aetiology remains a topic for debate. The disorder is more common in girls than boys and often appears during adolescence. Cultural factors may reinforce the fear of fatness and evidence suggests that *anorexia nervosa* is becoming more common in countries where traditional attitudes to weight are replaced by fashionable ideals of thinness. Neurodevelopmental disorders may precede *anorexia* and, in a small minority, *anorexia* follows sexual abuse. *Anorexia nervosa* still carries a significant mortality. While approximately one-third make a full recovery, many remain vulnerable, psychiatrically disturbed and requiring repeated periods of therapy; some require hospitalisation.

In treatment, prescribed food is taken regularly. This may involve the exhausting task of sitting with the patient until food has been finished and after that for at least another hour. Where the patient is very underweight, diet should be built-up gradually, with dietetic advice. In very severe cases, if re-fed too rapidly, acute gastric dilatation can develop and re-feeding syndrome can be fatal.

Family therapy approaches involve supporting parents in understanding the disorder and taking greater control at mealtimes. Cognitive behavioural approaches to anorexic beliefs are helpful once a patient has recognised their problem and can engage in individual work. Intensive day-patient programmes that involve group dynamics can enable youngsters to enforce their own dietary control. Sometimes antidepressants or neuroleptics are used, but dosage should be gradually built-up if the patient is frail.

Those who pursue a relapsing course often develop *bulimia nervosa*, where there is intermittent bingeing, often with very large amounts eaten, followed by self-induced vomiting or purging. As with anorexia, treatment plans must be clear, often with contracts drawn up so that therapy is underpinned with behavioural objectives.

## PSYCHOTIC DISORDERS

Symptoms such as hallucination which are suggestive of psychosis require careful assessment in childhood, but true psychoses are very rare in younger children and when they occur an organic cause should be suspected. Careful medical review is required including consideration of a range of disorders such as temporal lobe epilepsy, infectious, inflammatory and degenerative disorder as well as toxic effects of heavy metals and substance misuse. Mental state examination in children requires particular skill. Where children have not established good communication or clear boundaries between fantasy and reality, it is a highly complex task to use diagnostic criteria derived from adult psychiatry. Children with communication disorders and learning disability may present symptoms suggestive of psychosis, but are at particular risk of misdiagnosis, as well as being at increased risk of psychosis. Psychoses, such as schizophrenia and hypomania, become more prevalent in adolescence.

Treatment approaches need to take account of the young person's stage of development. Family involvement is important and, in particular, neuroleptic drugs have higher rates of side-effects in younger people and doses need careful consideration.

### Case Study

A 9-year-old living with socially isolated parents is seen by an education officer concerned about non-attendance. He has stopped sleeping at night and plays computer games for hours. He appears distracted by what he describes as "voices of aliens". He recovers quickly in a psychiatric unit, where MRI scanning shows cortical dysplasia, consistent with his abnormal pattern of cognitive skills. His psychosis is seen as a consequence of abnormal functioning within an abnormal environment and medication is not required.

## COMMUNICATION DISORDERS

Normally children are taught language by a two-way process of interaction with an adequately responsive mother or other caring adults. It is a pleasure to watch the intent eye-to-eye contact as the infant sits on the mother's knee while producing baby vocalisations that are praised by the mother as they approximate to some simple well-known word like "Mum". As the noises approximate to the word "Mum" the mother responds, the baby excites and the dialogue slowly and surely proceeds into a basic vocabulary where the child develops some understanding of the meaning of words as well as being able to articulate them. For this process to occur hearing must be intact, the auditory nerve functioning and incoming stimuli from the input side of the brain must work in harmony with memory so that messages can be devised in the output or expressive part of the brain and these coded into impulses going down the motor nerves to the larynx and pharynx. If a child presents with defective speech or language it is worth being satisfied that there is no deafness or even high tone deafness. Some children can imitate the alarm of a fire engine but the frequencies needed to imitate the human voice may not be received in which case incoming language can only be perceived as distorted. If hearing is unimpaired and there are no anatomical or neurological problems of sound producing organs, one can assume that the disorder is in the brain. In practice, most language disorders are not clearly defined, being mixed or central with both receptive and expressive difficulties, but it can be helpful to think separately of receptive or expressive language impairments.

Where there is delay in *expressive* communication, the child clearly understands what is being said and will obey verbal instructions, but has hesitancy in finding words to express him. Children with this problem are irritable and demanding, as they live in a frustrating world of adults moving on to the next topic before they have been able to join in. There is frequent gesticulating, pulling parents over to indicate their wishes by body language and general upset. Providing the child is socially aware and develops an understanding of language the problem may resolve with support and possibly speech and language therapy.

In *receptive language impairments*, impulses coming along the auditory nerve can be difficult to decode into anything meaningful. Some children appear to repress language to the extent that they may be thought to be deaf and on occasions it requires an audiogram to be performed with an electroencephalogram (EEG) machine set to give evoked response readings. In this way, it can be deduced that the brain receives noises coming into the child's ear. If little meaningful sense can be made of the spoken word the child becomes seriously socially disadvantaged and may begin to

withdraw from a world, which increasingly depends on social interaction through language. Children with severe receptive disorders require special education so that a language can be build-up with stimuli presented through visual or tactile routes.

*Autistic spectrum disorder (ASD)* is a concept that provides a useful way of thinking about various more severe disorders of communication that in ICD-10 are categorised as *pervasive developmental disorders*. The core of the difficulties faced in ASD lies in the *autistic triad* of impairments of communication, social development and behavioural rigidity. The recognition of ASDs is the first step towards ensuring that such children achieve their developmental potential. Specific treatments have a limited evidence-base, but early supports for parents, later educational and social interventions, individually tailored, can reduce the impact of a child's impairments.

The signs of *infantile autism* usually present within the first 30 months with abnormal responses to both auditory and sometimes visual stimuli. Speech is delayed and if it begins to develop it tends to be echolalic and later lacking in ability to use abstract terms. Autistic children appear detached socially and classically there is impairment of eye-to-eye contact and lack of ability to relate meaningfully to parents or age-mates. Autistic children frequently resist change and may have catastrophic rage reactions for minor causes, e.g. if an item in a room has been moved or if their transport to a school goes by an unusual route. Routines, rituals and obsessional behaviour are commonplace and if the disorder improves patterns of logically concrete thinking emerge with a lack of social empathy.

There are a number of theories of possible aetiology. The disorder is male predominant, but not X-linked. Whereas in the past family influences were suspected it now seems clear that genetic factors are highly relevant, with multiple interacting genes and high heritability. Associated medical disorders (e.g. specific disorders of the brain such as tuberous sclerosis) are found in more than 10%. Better prognosis is found where there are no signs of severe learning disability. Many require ongoing family, educational and social support with only a minority achieving more positive adjustment. A few truly gifted individuals achieve great success in areas less dependent upon their areas of difficulty, for example as musicians or scientists.

*Asperger's syndrome* has been conceptualised as high functioning autism, but this may be misleading as the social deficits of this condition can be as disabling as in infantile autism. The criteria for diagnosis of Asperger's syndrome in ICD-10 are open to debate, but the syndrome differs from infantile autism in that the level of speech and language impairment is much less obvious. Such children will still have marked impairments in language in areas such as

semantics (the construction of meaning) and pragmatics (the use of language in social interaction). There appears to be increased recognition of this disorder as more subtle social impairments are identified and labelled.

*Atypical autism* is a term that is sometimes applied to children with marked autistic features who do not fulfil criteria for another diagnosis, especially where there is learning disability.

*Rett's syndrome* is a rare genetic disorder leading to autistic regression with a characteristic pattern of abnormal hand movements.

## DISORDERS WITH MOTOR PRESENTATIONS

Children may present in paediatric clinics with a range of motor disturbances that are best managed with the skills of a child psychiatrist. Repetitive stereotyped movements are common features of autism and may need to be distinguished from self-stimulating behaviours, which are also common in developmentally impaired children. *Tics* are rapid repetitive movements that are driven by an internal compulsion that older children may describe as "like an itch", they are often self-limiting. Tics are usually motor phenomena, but can also be vocal, such as grunting or throat clearing. It can be helpful for children and families to understand that tics are basically involuntary although some children may learn to control some of their manifestations.

*Tourette's syndrome* is diagnosed when both motor and vocal tics occur for a sustained period; vocal tics may progress to explosive and sometimes culturally unacceptable utterances. In themselves tics rarely require treatment but when they cause significant impairment a child may benefit from psychological therapies or one of a number of medications, of which clonidine or guanfacine are the least likely to cause harmful long-term side-effects. Tourette's syndrome often co-exists with obsessive/compulsive behaviours or attentional problems and in a few children these difficulties may be triggered by group B streptococcal infection associated with Sydenham's chorea. The fascinating hypothesis that a range of psychiatric symptoms may be triggered by streptococcal disease without associated neurological signs reflects increasing interest in autoimmune processes within the nervous system.

Motor over-activity is a core feature of ADHD, but symptoms of motor restlessness or of immobility can more rarely be seen in childhood affective states and psychosis, including rare cases of childhood catatonia. Awareness of the link between specific disorders of motor development (dyspraxias) and other developmental and psychiatric disorders should lead to careful global assessment when problems in areas such as co-ordination and visuospatial capacity are identified.

## PROBLEMS OF LEARNING

Many disorders can directly or indirectly affect learning. Children with emotional disorders are frequently anxious and depressed. They find it difficult to concentrate in class if they are preoccupied by feelings of worthlessness and are worrying that their mother or father may be unwell or in the process of separation. Their distress and falling off of attainments may be missed by the teacher who is more preoccupied by disruptive behaviourally disturbed children. Somatic symptoms, including abdominal pains and headache, lead to frequent school absence and the continuity of learning is lost.

A child with a chronic or relapsing illness may find learning difficult because of malaise, pain, repeated time consuming or traumatic medical treatments and due to time lost from school. The side-effects of medications, e.g. anticonvulsants are important causes of cognitive impairment.

Attainments are frequently poor in conduct disordered children. The causes are multi-factorial. In areas of social deprivation, parents' attitude towards education is not always positive, homework is not encouraged and there is no space to work in overcrowded, noisy, disorganised households. A youngster, behind with his attainments is frequently criticised by teachers. If the child believes that he cannot learn, his motivation will be adversely affected. A mental process guarding against depression and poor self-esteem is to blame the system. It is safer to reject the school and denigrate the teachers than to accept criticism. This attitude can become the group norm and outshining truanting colleagues with anti-social behaviour can preserve self-respect. Under these conditions school attainments fall further and further behind.

In a number of cases, constitutional difficulties with attention, concentration or more specific learning skills precede behavioural difficulties. Where such difficulties are not discovered and educational help is not given, a child's self-esteem and motivation worsens and the situation escalates.

*Specific learning difficulty* is described when children with otherwise normal developmental capacity demonstrate defined problems in one area of learning or development, e.g. dyslexia is specific reading retardation and dyscalculia a similar problem with numbers. There has been enormous pressure from some professionals and parents to get such problems recognised by teachers. Specific learning difficulties may present with depression or conduct disorder. Impressed by a youngster's unhappiness or suicidal ideas, it is all too easy to miss the underlying stress of a child trying his/her hardest and never being able to succeed at school. If a child does not have the innate ability to cope with an aspect of learning it is often wrongly assumed that extensive practise will improve the situation but often the converse

is true. It is not surprising that such children may feel despairing and only careful attention to their specific needs will offer a way forward. However, the term "dyslexia" can give rise to confusion. Worried parents can be fearful that dyslexia is some frightful illness; others may use this as an explanation for a school failure that is rooted in other factors. The problem about this label is that it does not describe the precise nature of the underlying learning difficulty. Many professionals prefer to describe the nature of the problem in functional terms.

Three cognitive processes are often found to be affected in specific reading retardation. The first is a problem of short-term memory or a sequencing difficulty. This may be associated with difficulty of recall of information obtained through the auditory route, or the problem may be in recalling material, which has recently been read from writing or print (e.g. a person can be told a telephone number and not recall it, whereas they can retain the same number read from a book or vice versa). The second major difficulty is with spatial ability, for example some children have enormous difficulty in learning left from right. The third problem area may be visuomotor or perceptual difficulties. This is often associated with problems of putting thoughts into legible writing and decoding information from the written page. In some instances, a child may acknowledge that his written page is full of mistakes, but be unable to correct them.

Severe dyslexic problems may overlap with mild communication disorders and specific learning difficulties can be found in association with hyperkinesis or in children who are clumsy with poor motor control. Three disorders, namely: (1) ADHD, (2) specific learning difficulty and (3) specific disorder of motor development (dyspraxia) are sometimes grouped together. Aetiological theories are covered above in relation to ADHD.

Severe head trauma, cerebral tumours and other forms of brain injury in childhood may impair learning. Intellectual abilities may appear remarkably intact after marked anatomical damage has occurred, especially if early in the child's life. However, such brain-injured children may become more obviously disabled as the demands of development outstrip their capacity.

A child who has problems affecting all aspects of cognitive development is described in ICD-10 as "mentally retarded" although groups in the United Kingdom have campaigned effectively for the term "learning disabled" to be used as it is less stigmatising. Stigma is compounded when a child looks dysmorphic or has an associated movement disorder. Learning disability generally does not have an identifiable cause but various aetiologies are recognised. The commonest single cause is chromosomal disorder, e.g. Down's syndrome. There are a number of genetic disorders where an inborn error of metabolism can be proven; for example,



Wilson's disease, which is a defect of copper metabolism and the mucopolysaccharide disorders, which are progressive. Screening at birth allows for intervention to prevent the insidious mental retardation resulting from phenylketonuria and hypothyroidism. Children born with neurological impairments, such as spastic hemiplegia, frequently have learning disability. There are many rare medical causes of deteriorating cognitive capacity or dementia in childhood.

### WORKING WITH SOCIAL SERVICES AND POLICE

Professional responsibility in dealing with children includes a responsibility to work within a legal framework governing the acceptable treatment of children as well as attending to the childhood roots of adult criminality. It is important that doctors familiarise themselves with the social arrangements and statutory procedures for liaison with social work departments (or their equivalents) and where necessary with the Police and the Courts or equivalent legal bodies. In Scotland, the children's hearing system is designed to attend to youth offending as well as child welfare in the under eighteens.

In certain circumstances, a professional opinion is sought in relation to severe offending behaviour in children. Adult approaches to forensic examination need to be modified to take account of developmental factors and the influence of family and social factors must be acknowledged. Careful notes should be kept of forensic interviews and examinations. Cultures vary in their attitude to anti-social behaviour in childhood but it is generally accepted that the younger the child the more their behaviour must be seen in the context of age. Punishment may then seem less important than attempts to intervene to reduce the risk of further offending.

*Physical abuse* is often relatively easy to recognise and prove, while *sexual abuse* may be devoid of physical findings. The signs that arouse suspicion of sexual abuse are now legion. Apart from obvious trauma, infections or pregnancy, there is an increased incidence of psychogenic pains, often abdominal, and conversion symptoms that may indicate that a child is under stress which is too difficult to go on tolerating and too difficult to be disclosed. A range of psychiatric symptoms may occur or be made worse as a result of abuse.

The way in which the child behaves should be noted. Abused children may be fearful of adults and appear apprehensive or withdrawn; particularly where circumstances recall the abuse, e.g. a male doctor reminds the child of a male abuser. If a child is taken to a playroom and cowers in the corner when the therapist closes the door this can be very revealing. Children often replicate confusing or worrying incidents in their play. Children's drawings may also indicate fears of sexual objects or sexual knowledge beyond what is age-appropriate. Most of all it is important to listen to what

the child has to say. Although children can be regarded as manipulative, it is very unusual (but not unknown) for children to disclose abuse that has not actually occurred. They are more likely to remain mute or ill at ease in order to protect their perpetrators.

If sexual abuse is suspected, it is important that arrangements for paediatric examination give due weight to the emotional needs of the child. Provision of special units with quietness and appropriately comfortable furnishing is helpful. In this setting, full explanations can be given and trust built-up between the child and the examining doctor. The skills of being frank and open at a level the child can understand, seeking the child's permission and talking them through the examination go some way to reducing the secondary emotional damage from the fear resulting from disclosure. Attempts to tussle with the child to perform a physical examination must increase the horror of abuse. If a parent or relative has been the perpetrator and then doctors remove the child's clothes and intrude into the child's personal space, it must seem as if no adult can ever be trusted again.

Although dialogue with the child or interpretation of his/her behaviour sometimes leaves little doubt to the clinician that abuse has occurred, the legal system is not always well-equipped to cope so that a number of cases are not proven with resulting further difficulties for those managing the case. Perhaps most difficult of all are the categories of *emotional abuse* and *failure to thrive* where the parents contest the need for intervention. Close co-operation is required across the agencies involved.

*Factitious and induced illness (FII)*, formerly known as Munchausen Syndrome by Proxy or Meadow's Syndrome, is described when children are repeatedly brought to hospital with symptoms which tempt the physician or surgeon to subject the child to numerous investigations, sometimes of an increasingly intrusive, traumatic and expensive form. While many anxious parents unwittingly subject their children to the effects of their anxiety and over concern; in FII the problem is that the parent is usually doing something actively to produce the child's symptoms. Mothers have used their own blood to contaminate a child's urine specimen to precipitate investigations for haematuria and anoxic seizures have been deliberately produced by mothers partially suffocating their children. Such problems may be more likely in medical systems where care is compartmentalised by specialty and consideration of psychosocial mechanisms neglected. Surgical intervention or complex treatment regimes may be set-up but the problem fails to resolve. Mothers of children with FII often have personality disorders. They are often co-operative, adapt well to ward routine and are well-acquainted with hospital, where their emotional needs may be met. It is difficult to empathise with their psychopathology

and dissociation may be present. The ability to play the competent caring mother and yet behave destructively in order to gain input from doctors and nurses is hard to comprehend. Confrontation is often not met by an admission of guilt and it is important that appropriate child protection orders are sought. Sometimes after confrontation the parent may decompensate. A needy, distraught mother feels she has failed once again. Adult psychiatric intervention may be necessary as depressive feelings are mobilised when the mechanism of dissociation is broken down.

### ACKNOWLEDGEMENTS

The authors wish to acknowledge the published work of RS Illingworth and DW Winnicott, two paediatricians whose influence has shaped medical practice in support of children and young people's mental health.

### FURTHER READING

#### Reference Works

1. Garralda E, Hyde C. *Managing Children with Psychiatric Problems*. London: BMJ Books; 2002.

2. Green C. *New Toddler Taming: The World's Bestselling Parenting Guide*. Vermilion; 2005.
3. Goodman R, Scott S. *Child Psychiatry: Key Facts and Concepts Explained*. Blackwell Publishers; 2005.
4. Turk J, Graham P, Verhulst F. *Child and Adolescent Psychiatry, A Developmental Approach*. Oxford University Press; 2007.
5. Rutter M, et al. *Rutter's Child and Adolescent Psychiatry*, Wiley-Blackwell; 2010.

#### Background Reading

6. Illingworth RS. *The Normal Child*, 10th edition. Churchill Livingstone; 1991.
7. Fadiman A. *The Spirit Catches You and You Fall Down*. Farrar, Straus and Giroux Inc; 1998. (The experience of childhood epilepsy amongst the Hmong Chinese in USA).
8. Haddon M. *The Curious Incident of the Dog in the Night-time*. Vintage; 2004. (Growing up with Asperger's syndrome in England).
9. Dangarembga T. *Nervous Conditions*. England: Ayebia Clarke Publishing Ltd; 2004. (Developing eating disorder symptoms, caught between cultures in Africa).

# Paediatric Radiology

## GENERAL CONSIDERATIONS IN PAEDIATRIC RADIOLOGY

General considerations in paediatric radiology are as follows:

- Imaging has assumed an important role in the diagnosis, understanding and in certain cases, treatment of paediatric diseases.
- The availability of many imaging modalities [plain film, ultrasound, computed tomography (CT), magnetic resonance imaging (MRI), nuclear medicine, angiography, single photon emission computed tomography (SPECT) scanning] requires problem-oriented decisions to determine which techniques should be used or omitted in any given clinical situation.
- The radiologist plays a central role in the diagnostic imaging process and is actively involved in formulating an appropriate pathway of diagnostic evaluation to maximize the benefits from any imaging examination.
- Adequate clinical information should always be available on the radiology consultation in order to determine, what, if any, imaging modalities are indicated for diagnostic evaluation.
- Open communication between the referring physician and the radiologist improves quality of patient care.
- There is no place for routine radiological examinations.

## RADIATION EFFECTS ON CHILDREN

Effects of radiation on children are as follows:

- The biologic effects of radiation result primarily from damage to DNA and the effects are greatest on fastest growing organisms—the foetus, infant and the young child. All ionising radiations are potentially harmful.
- The consequences of radiation relate to both dose and time of radiation and may appear later in life. There is no existence of a threshold dose in unknown.
- The ALARA principle states that radiation dose of exposed individuals should be kept as low as is reasonably

achievable, with economic and social factors being taken into account.

- Medical diagnostic X-rays represent the largest source of radiation exposure resulting from human activity. The greatest source of background radiation is radon gas, a decay product in the uranium series.
- Imaging modalities which deliver ionizing radiation are plain films, fluoroscopy, CT and isotope studies. The modality which delivers the highest dose is CT and use of this modality is increasing with children (0–15 years) receiving 11.2% of all CT examinations.
- All effective methodologies to reduce radiation exposure in children should be employed. These include tailoring the examination to the child, adjusting technical factors for plain films, using pulsed fluoroscopy, screening of CT examinations, and utilizing other modalities which do not involve ionising radiation like ultrasound and MRI.
- Radiology consultation should be obtained to obtain a proper test. Factors utilized in determining the best test include sensitivity in diagnosis, cost, timeliness and safety.
- Dose may be decreased by performing only examinations that are clinically indicated.

## IMAGING MODALITIES USED IN PAEDIATRIC IMAGING

### Plain Film Radiography

Conventional radiography is based on the variable attenuation of an X-ray beam as it passes through tissue.

This modality is frequently a starting point for radiological investigations in a number of conditions. The radiology request should provide adequate clinical information and specify the views.

There are standard views for specific anatomic areas and specific conditions.

Head: Anteroposterior (AP), Towne and lateral

Spine: AP and lateral

Chest: Frontal and lateral

Abdomen: AP

Pelvis: AP

### Contrast Media

Contrast media are externally administered agents used to provide positive or negative contrast in certain areas of the body. Areas where contrast media are frequently used include gastrointestinal tract, genitourinary tract, and the vascular system. Barium compounds (Barium sulphate) are used for routine gastrointestinal studies. Water soluble iodinated compounds are used for assessing the gastrointestinal system in emergency cases or where perforation is suspected, for the genitourinary system, the cardiovascular system and CT scanning. Water soluble contrast agents contain iodine. Low osmolar iodinated contrast media should be used as a routine. High osmolar contrast media can have a profound effect on serum osmolality and the haemodynamics status of infants and children.

### Fluoroscopy

Indications include gastrointestinal, genitourinary studies, orthopaedic procedures, and diagnostic angiography and during IGT procedures. Image intensification is necessary for fluoroscopy of children and most procedures usually involve contrast medium administration. Techniques reducing radiation doses in children without any significant loss in image quality include pulsed fluoroscopy, last image hold and collimation.

### Ultrasound

Ultrasound is ideal for imaging children for a number of reasons:

- Uses no ionising radiation
- Sedation is almost never required
- There is no evidence that energy levels of diagnostic ultrasound used in humans are harmful to humans
- Examination can be performed at the bedside in sick children
- Paucity of fat in the paediatric abdomen and the smaller size of the patient allow detailed visualisation of the abdominal anatomy.

Indications include intracranial examinations in neonates, urinary tract infections, abdominal pathology, scrotal conditions, anomalies of soft tissues, and certain chest conditions and for interventional procedures.

### Computed Tomography

Computed tomography uses a radiation beam that is highly collimated through one cross-sectional slice of tissue from different angles. The data is then computed to record X-ray absorption in a specific volume element which is then converted to an image. CT has high spatial resolution and demonstrates anatomy as a two-dimensional image which

helps determine extent of disease. Recent advances in CT and software technology now allow CT imaging in a volume of tissue such as the abdomen in less than 5 seconds and also enable reconstruction of the image in any plane including 3-dimensions.

A major disadvantage in children is the radiation dose.

### Magnetic Resonance Imaging

Magnetic resonance imaging uses a strong magnetic field and radiofrequency energy to generate a synchronised precessional motion of protons in body tissues.

An MRI image reflects the distribution of protons in the section of the body.

Applications of MRI are gradually increasing in paediatrics. Reasons include lack of ionising radiation, multiplanar capabilities, superior contrast resolution and the ability to image blood vessels without using intravenous contrast agents. In addition to illustrating normal and pathologic anatomy magnetic resonance imaging (MRI) is also used to assess chemical composition and tissue perfusion.

Disadvantages include need for sedation or anaesthesia in younger children and the examination is contraindicated in children with pace makers and certain implants.

### Radio Isotope Studies (Nuclear Medicine)

The imaging energy source for scintigraphy is the isotope attached to a radiopharmaceutical injected into the body. The detection system, a gamma camera, uses a collimator and photo-multiplier tubes to detect the gamma rays emitted from the body to a scintillation crystal. The raw data from the scintillation crystal then yields a raw image after computer reconstruction and signal processing. Most radio isotopes are injected intravenously and the functional information provided by scintigraphy often complements the anatomic information provided by anatomical studies and may provide the only imaging evidence of pathology. Radiopharmaceuticals are given in small doses and are relatively innocuous, i.e. they do not produce significant pharmacologic, haemodynamic, osmotic or toxic effects. Radiation exposures from their use in diagnostic imaging usually fall in the lower range of radiation exposures from common radiological examinations.

The technique has high sensitivity but low specificity.

Common radio isotopes include  $^{99m}\text{Tc}$  DMSA,  $^{99m}\text{Tc}$  DTPA, and  $^{99\text{Tcm}}$  MDP.

### Image Guided Therapeutic Procedures

A steady increase in non-vascular and vascular image guided therapeutic (IGT) procedures has occurred in the last decade. This increase stems from the growing recognition that many paediatric interventional procedures like their counterparts in the adult world can achieve the same results as surgery without being as invasive and usually with less morbidity and more rapid recovery.

Most of the interventional procedures are performed with ultrasound and fluoroscopic guidance. Use of contrast media is made at every stage, if indicated, as an additional safety margin.

Non-vascular IGT procedures include biopsies, drainages, of pleural fluid, abscesses, other fluid collections, balloon dilatation of oesophageal strictures, percutaneous nephrostomy, pyeloplasty, percutaneous gastrostomy/gastrojejunostomy.

Vascular interventional procedures include image guided central and peripheral central venous catheter placement, sclerotherapy of vascular malformations, angioplasty, embolisation and trans-jugular liver biopsy.

## RESPIRATORY AND CARDIAC

### The Child with Cough and Fever

#### Common Causes

Acute pneumonias:

- Viral
- Bacterial
- Atypical organism.

Other pneumonias:

- Tuberculosis
- Aspiration
- Cystic fibrosis (CF)
- Opportunistic organisms.

#### Viral Pneumonia



**Fig. 32.1:** Viral pneumonias are mainly small and large airway disorders and radiological findings are due to partial and complete airway occlusion leading to atelectasis and hyperinflation. Chest radiograph in a month old baby with viral pneumonia showing hyperinflation and atelectasis of the lingula (seen as effacement of the left heart margin) and the middle lobe (seen as effacement of the right heart lobe)

#### Bronchiolitis



**Fig. 32.2:** Bronchiolitis is a serious manifestation of a lower respiratory infection occurring in infants in the first 2 years of life. Radiologically air trapping and atelectasis are the common features. The infection is caused by the respiratory syncytial virus (RSV). Bronchiolitis with air trapping and right apical pneumothorax (arrow). Additional findings include bilateral parahilar infiltrates and atelectasis

#### Bacterial Pneumonia



**Fig. 32.3:** Bacterial infections present as lobar or segmental consolidations or fluffy infiltrates. Even though consolidation may be extensive, volume loss may be minimal. The organisms are commonly *Haemophilus influenzae* in infants less than 2 years and *Streptococcus pneumoniae* in older children. Chest X-ray (CXR) showing segmental consolidation in the left upper lobe with air bronchograms (white arrow)

## Round Pneumonia



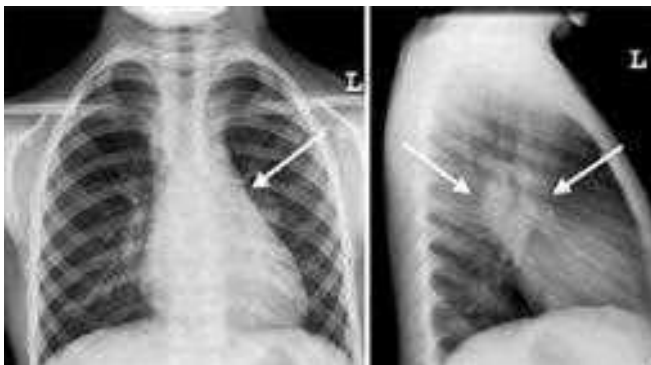
**Fig. 32.4:** A round pneumonia (arrow) is seen exclusively in children, usually in the superior segment of the lower lobes. Consolidations in the early phases may appear rounded and one should not be misled by their appearance which is strictly fortuitous. It can be mistaken for a neoplasm but a history of an acute illness and the extreme rarity of such neoplastic lung nodules in children should confirm the diagnosis. Causative organism is commonly *Streptococcus pneumoniae*

## Cystic Fibrosis



**Fig. 32.6:** An autosomal recessive error in chloride ion transport results in thick tenacious mucous. Clinical manifestations result from bronchiectasis, lung abscesses, air trapping, airway obstruction and right heart failure. On chest radiograph early CF can be seen as hyperaeration and bronchial wall cuffing. Mucoïd impaction is seen as finger like densities radiating from the hilum. Bronchiectasis is seen as tram tracks radiating from the hilum. Chest radiograph showing lung hyperinflation, patchy infiltrates and peribronchial thickening and dilatation in a 11-year old patient with cystic

## Primary Pulmonary Tuberculosis



**Fig. 32.5:** Primary pulmonary tuberculosis results from inhalation of the organism from an infected individual. The radiologic hall mark is unilateral hilar or paratracheal lymphadenopathy, very often accompanied by atelectasis due to compression of the bronchus by the enlarged nodes. Frontal and lateral CXR showing left hilar adenopathy in a patient with cough and fever (arrows)

## Bronchiectasis



**Fig. 32.7:** High resolution CT confirms the presence and extent of bronchiectasis. Evaluation of segmental/lobar involvement is important if surgery is contemplated. CT scan showing cystic bronchiectasis in the right lower lobe

## Inhaled Foreign Body



**Figs 32.8A and B:** Airway obstruction by foreign body (FB) usually affects toddlers and presents with stridor, wheezing, cough or pneumonia. The FB which can be radio or non-radio-opaque usually lodges in bronchi (right commoner than left) and can obstruct the airway. Total obstruction can cause collapse. Partial obstruction can cause ball valve effect permitting air to enter but not leave the lungs. The affected side will demonstrate air trapping made prominent on expiration. (A) Inspiratory and; (B) Expiratory radiographs showing air trapping in the right middle lobe on expiration (arrow)

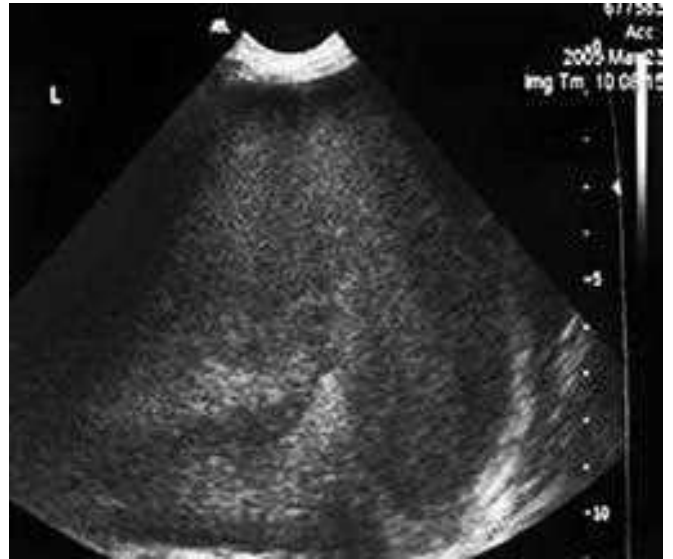
## Complications of Pneumonia

### *Empyema*

The appearance of pleural fluid in the setting of pneumonia suggests an empyema. Ultrasound (US) and CT scanning reveal helpful information such as depicting whether the effusion is loculated or free, clear or containing debris. Image guided drainage can be done using ultrasound and fluoroscopy to accurately place the drainage catheter.



**Fig. 32.9:** CXR of a 6-year-old girl showing an opaque left haemithorax due to a large empyema. Note the scoliosis concave to the left



**Fig. 32.10:** Ultrasound scan in the same patient as above shows debris in the pleural fluid

## Lung Abscess

Suppurative parenchymal complications represent a spectrum of abnormalities and include cavitory necrosis, lung abscess, pneumatocele, bronchopleural fistula and pulmonary gangrene. When lung first becomes necrotic, the necrotic tissue liquefies and forms fluid filled cavities. When portions of this necrotic fluid are expectorated via bronchial communications, the cavities may fill with air. CT is more sensitive to earlier detection of lung abscesses, can assess proximity to pleura and plan drainage.



**Fig. 32.11:** CXR showing an abscess in the right lower lobe containing an air fluid level

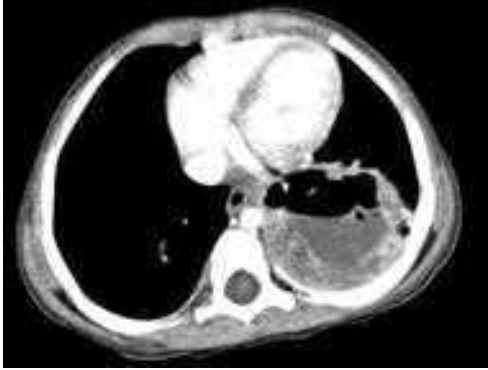


Fig. 32.12: CT scan in another patient showing left basal lung abscess

### Pneumatocoeles

Pneumatocoele is a term given to thin-walled cysts seen at imaging and may represent a later stage of healing necrosis.

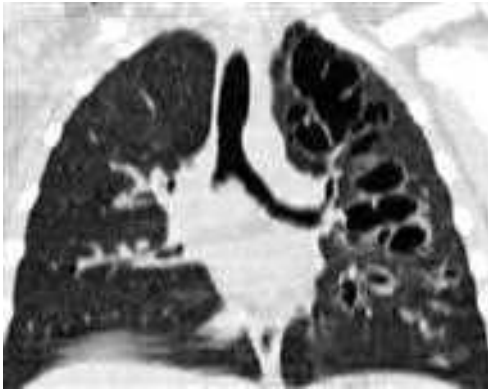


Fig. 32.13: Coronal CT reconstruction shows left upper lobe pneumatocoeles as thin-walled cysts containing air

### Bronchopleural Fistula

Bronchopleural fistula is identified on CT when a direct communication is visualised between the air spaces of the lung and the pleural space. There may be a chronic air leak.



Fig. 32.14: CT scan in a patient with necrotising right lower lobe pneumonia shows right basal consolidation (arrow) and a large right tension pneumothorax (asterisk). The site of the fistula is shown by the arrowhead

## The Neonate in Respiratory Distress

### Common Causes

1. *Medical:* Respiratory distress syndrome (Surfactant deficiency disorder), Transient tachypnoea of the newborn (retained foetal lung fluid), meconium aspiration, neonatal pneumonia.
2. *Surgical:* Intrathoracic air leaks, diaphragmatic hernia, Intrathoracic masses of the newborn (Congenital lobar emphysema, Congenital cystic adenomatoid malformation, sequestration, bronchogenic and gut duplication cysts).

Imaging: Chest X-ray, mainly frontal view. Lateral view to localise focal air collections/masses. Ultrasound for solid chest masses. CT/MRI for further assessment of radiologically detected masses.

### MEDICAL CAUSES

#### Respiratory Distress Syndrome or Surfactant Deficiency Disorder

Respiratory distress syndrome (RDS) results from a deficiency of pulmonary surfactant due to prematurity. Surfactant deficiency leads to instability and collapse of the alveoli producing diffuse micro-atelectasis, stiff lungs and impaired gas exchange with resultant respiratory distress radiologically, the lungs are diffusely involved with a granular pattern of opacification and abnormal air bronchograms.



Fig. 32.15: CXR on a premature baby with RDS done on day one shows generalised underaeration of the lungs, reticulogranular densities caused by acinar atelectasis and air bronchograms (arrow). Incidental note is made of the umbilical venous catheter lying at the inferior vena cava and right atrial junction (white arrow)





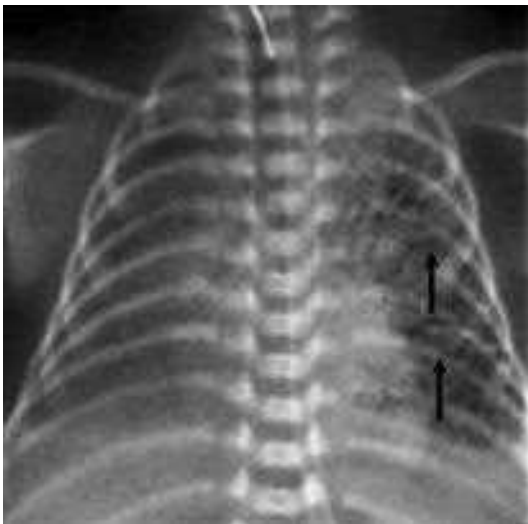
**Fig. 32.16:** Asymmetric surfactant deficiency disorder (SDD) in two patients due to administration of exogenous surfactant. CXRs show asymmetrical opacities in both lungs

Surfactant is now administered prophylactically in premature babies and in most infants the lungs clear rapidly. Since the surfactant is unevenly distributed throughout the lungs, the uneven distribution of surfactant leads to a radiographic appearance, which stimulates pneumonia or meconium aspiration syndrome.

### Complications of Respiratory Distress Syndrome

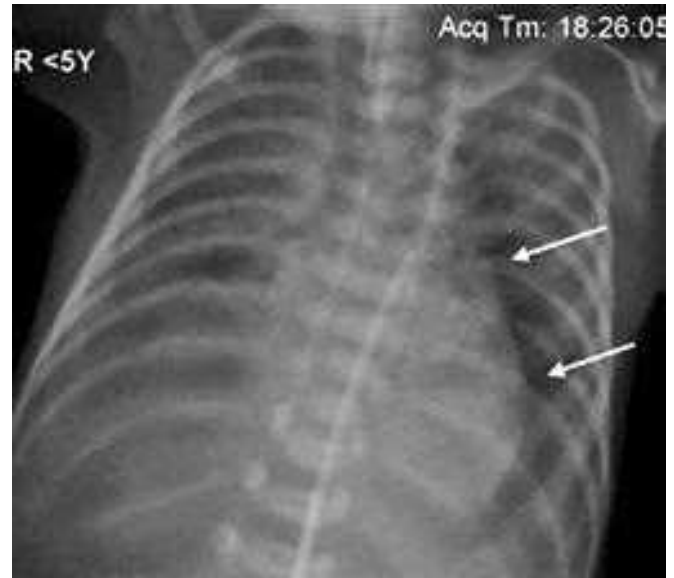
Iatrogenic or disease related complications might occur during the course of RDS. These include air leaks (pulmonary interstitial emphysema, pneumomediastinum and pneumothorax), tube malposition (Endotracheal, umbilical catheters), pulmonary haemorrhage and bronchopulmonary dysplasia.

### Pulmonary Interstitial Emphysema

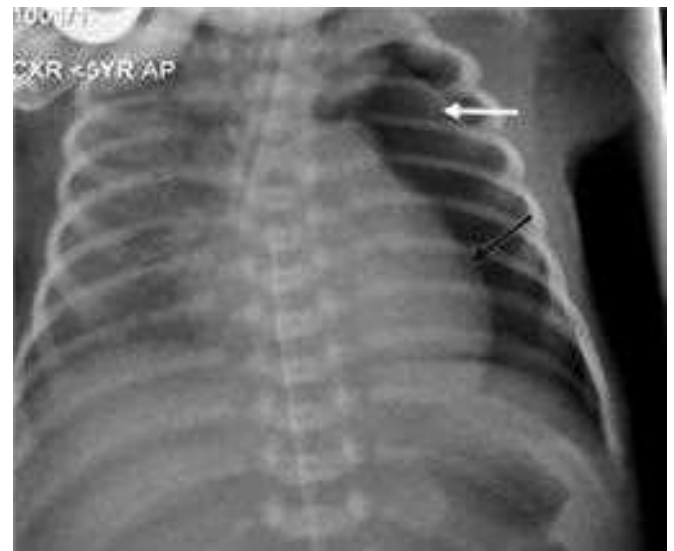


**Fig. 32.17:** Pulmonary interstitial emphysema (PIE) in the left lung. This often appears as pseudoclearing of SDD. Irregular and tubular densities (arrows) extending to the pleural edge are identified as pulmonary interstitial air. Peripheral PIE can produce sub-pleural blebs and can often rupture into the pleural space giving a pneumothorax or extend centrally to produce a pneumomediastinum or pneumopericardium

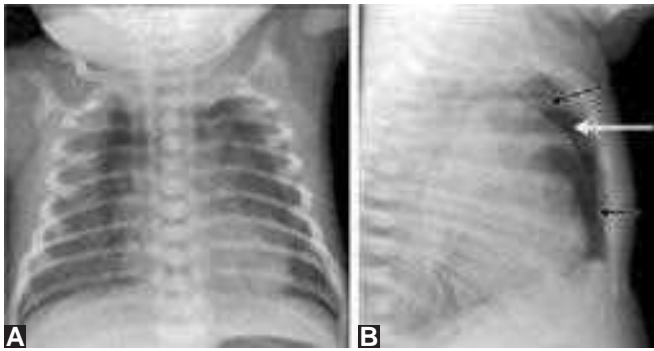
### Pneumothorax



**Fig. 32.18:** CXR showing an early left medial pneumothorax (arrows) in a 2 days old infant with RDS. When a pneumothorax collects medially, the findings must be differentiated from pneumomediastinum or pneumopericardium. Pneumomediastinal air tends to outline the thymus while pneumopericardium surrounds the heart entirely



**Fig. 32.19:** Anterior left pneumothorax in the same infant as above in a CXR taken about 10 hours after the above radiograph. In the supine position air accumulates over the anterior surface of the lung and produces a hyperlucent large hemithorax, increased sharpness of the ipsilateral mediastinal edge (black arrow) with a visible free edge of the left lung (white arrow). The thymus (T) may be compressed to form a pseudomass. Note the endotracheal tube (ETT) down the right main bronchus



**Figs 32.20A and B:** Pneumomediastinum: Frontal (A) CXR shows a large lucency overlying the mediastinum. Lateral view (B) shows the air collection in the anterior mediastinum (black arrows) lifting and outlining the thymus (white arrow)

### Bronchopulmonary Dysplasia

Bronchopulmonary dysplasia (BPD) is a distinct pulmonary disease affecting the developing lung after prolonged respirator or oxygen therapy of RDS. Also called chronic lung disease of prematurity, the radiological findings include bubbly appearance to the lungs, hyperaeration and cardiomegaly.



**Fig. 32.21:** CXR of a month old infant with BPD shows bilateral lung hyperinflation, bubbly appearance of the lungs and cardiomegaly

### Endotracheal Tube Malposition



**Fig. 32.22:** The ideal position of the ETT is 2.0 cm above the carina with the neonates head in a neutral position. CXR showing the ETT down the right mainstem bronchus with total atelectasis of the left lung and right upper lobe

### Umbilical Arterial (UAC) and Venous (UVC)

The umbilical arterial catheter (UAC) passes through the umbilicus, umbilical artery, internal iliac artery, common iliac artery and the abdominal aorta. It should ideally be placed away from the vessels to abdominal and pelvic viscera approximately at L3/L4 or T8/T10. The umbilical venous catheter (UVC) passes through the umbilicus, umbilical vein, medial part of left portal vein, ductus venosus, inferior vena cava (IVC) and right atrium.



**Fig. 32.23:** Chest and abdominal film showing UAC (black arrow) in distal thoracic aorta and UVC (white arrow) at the level of left portal vein

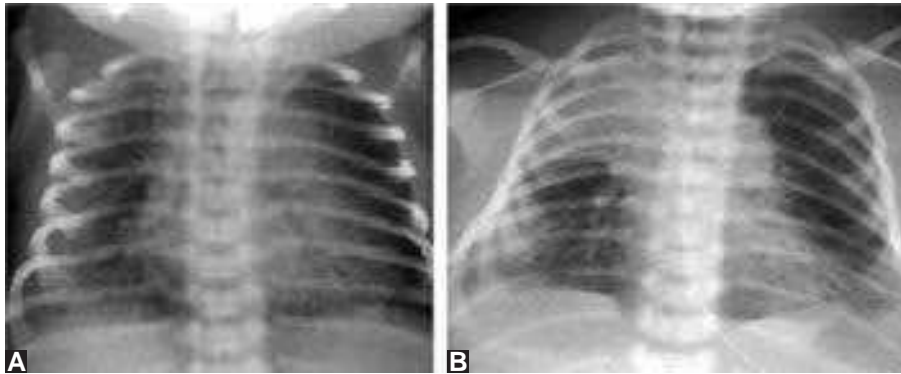
### Meconium Aspiration Syndrome

Meconium aspiration syndrome (MAS) is caused by the intra-uterine or intrapartum aspiration of meconium stained fluid in term or post-term infants. Aspiration of meconium into the tracheobronchial tree causes complete or partial bronchial obstruction leading to patchy areas of sub-segmental atelectasis and compensatory areas of hyperinflation. Meconium also causes chemical pneumonitis, which is complicated by bronchopneumonia.

Radiologically, there are patchy, bilateral asymmetric areas of rounded/linear opacities and marked hyperinflation. Air leaks such as pneumomediastinum, pneumothorax is seen in 25% of patients.

### Transient Tachypnoea of the Newborn (TTN)

Usually affects full-term infants, often following caesarean section or infants of diabetic mothers and is symptomatic within first 2–4 hours of life. It is caused by retained foetal lung fluid and treatment is supportive. CXR reveals normal lung volumes with interstitial oedema, which clears within 1 to 2 days.



**Figs 32.24A and B:** Term newborns with MAS. (A) CXR shows asymmetrical lung hyperinflation, patchy right basal infiltrates and areas of atelectasis; (B) CXR showing left and right upper lobe atelectasis and right basal infiltrates



**Figs 32.25A and B:** CXR in an infant with TTN taken day 1 (A) shows cardiomegaly and interstitial pulmonary oedema. Follow-up CXR day 2 (B) shows almost complete clearing of the lungs

## SURGICAL CAUSES

### Congenital Diaphragmatic Hernia

Left sided hernias, through the foramen of Bochdalek are commoner than right sided ones in the new-born. Variable quantities of intestinal contents, stomach and liver enter the chest during foetal life. The CXR shows an abnormal hemithorax, which is opaque initially but later, fills with bubbles representing gas filled bowel and contralateral mediastinal shift. The lungs are hypoplastic. The abdomen is small and narrow. Right-sided hernias are less common in the newborn and usually present later in life.

### Congenital Adenomatoid Malformation (CAM)

A congenital hamartomatous lesion characterised by proliferation of terminal respiratory bronchioles with no alveolar communication and usually presents in the neonate as respiratory distress. The lesion initially appears radio-opaque due to fluid filled cysts. As lungs aerate, these cysts



**Fig. 32.26:** Left diaphragmatic hernia: Many intrathoracic air-filled loops of bowel and absence of normal amounts of gas in the abdomen are seen in this neonate with severe respiratory distress. The prognosis correlates with the degree of underlying lung hypoplasia

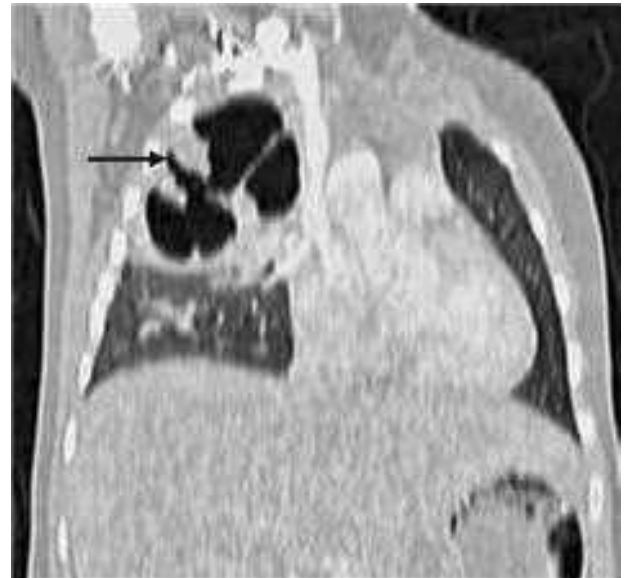


**Fig. 32.27:** CXR showing multiple cystic lucencies in the left hemithorax. There is mediastinal shift, which can cause progressive pulmonary hypoplasia. Note the multiple air filled loops of bowel in the abdomen and the intraabdominal nasogastric tube tip

gradually fill with air giving a 'cystic' appearance. The radiological appearance can mimic diaphragmatic hernia. A helpful differentiating feature is the presence of air filled loops of bowel in the abdomen. 10% of CAMs present after first year of life, often with recurrent pneumonias.

### Congenital Lobar Emphysema

Congenital lobar emphysema (CLE) initially appears as an opacification of one lobe or the whole lung due to partial bronchial obstruction causing retention of fluid. Over a period of few days the fluid is resorbed and replaced by air



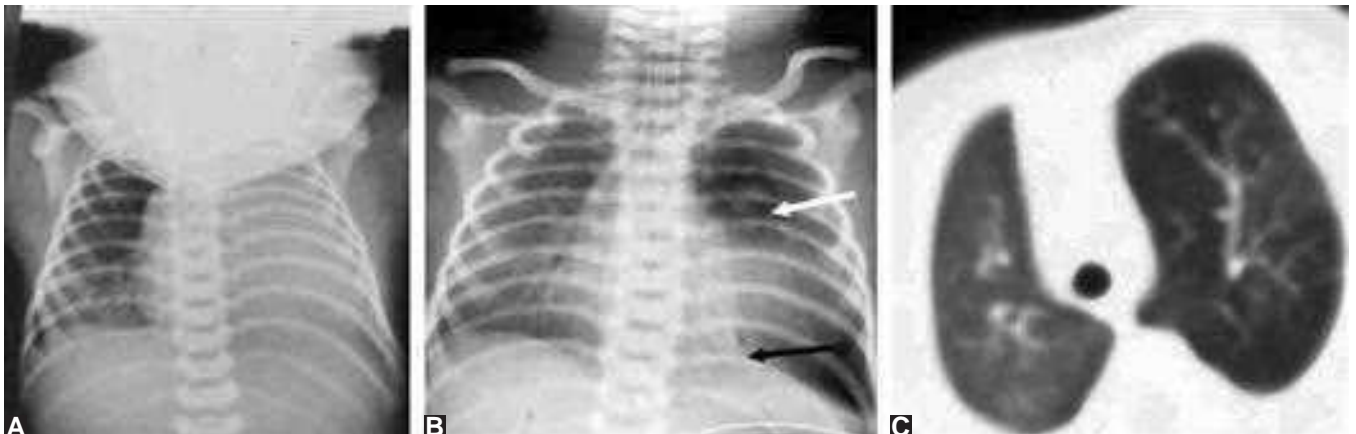
**Fig. 32.28:** Coronal CT reconstruction shows a CAM in the right upper lobe (arrow)

at which point the diagnosis becomes obvious. Progressive over distension results in air trapping and its consequences, namely mediastinal shift, compression of normal lung or lobes.

Common sites to be affected are left upper and right upper lobes.

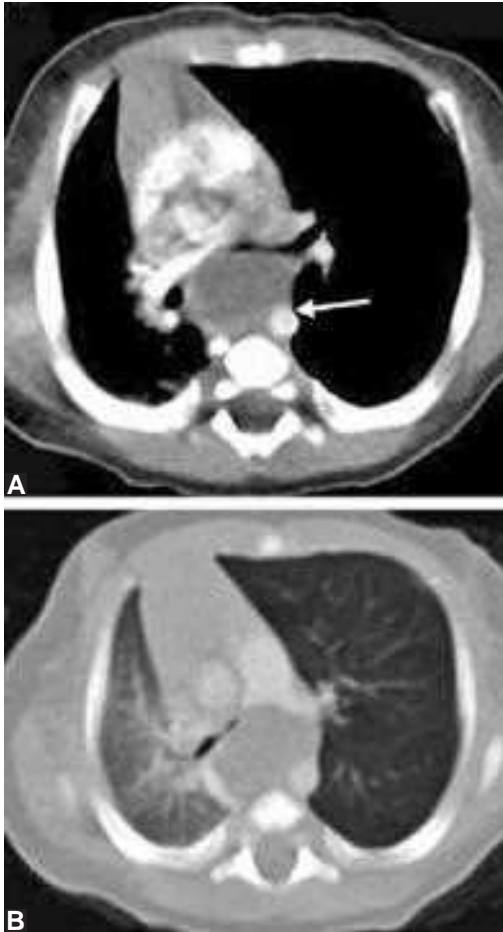
### Bronchogenic Cyst

Usually arise from an abnormal lung bud from developing foregut. The mediastinal form is usually asymptomatic but can present with respiratory distress if the major



**Figs 32.29A to C:** CXR (A and B) of a term neonate with respiratory distress. (A) Day 1 shows an opaque left hemithorax; (B) Day 2 shows a hyperinflated left upper lobe (white arrow) and compression collapse of left lower lobe (black arrow); (C) CT scan on day 3 shows an emphysematous left upper lobe and moderate mediastinal shift

airways are compressed due to gradual expansion over time. The cyst is often subcarinal in location and can be mistaken for a duplication cyst.



**Figs 32.30A and B:** (A) CT scans showing a posterior mediastinal cystic lesion (white arrow) causing compression of the left main bronchus (asterisk) and; (B) Hyperinflation of the left lung. Differential diagnosis includes duplication cyst of the oesophagus

### Neurenteric Cyst

Faulty neural tube closure results in abnormal mesenchyme leading to abnormal vertebral body formation and continued neural connection with endoderm. The abnormality is found most commonly in the thoracic spine with a cystic mass in the mediastinum and segmentation anomalies of the spine (butterfly vertebrae or hemivertebrae).

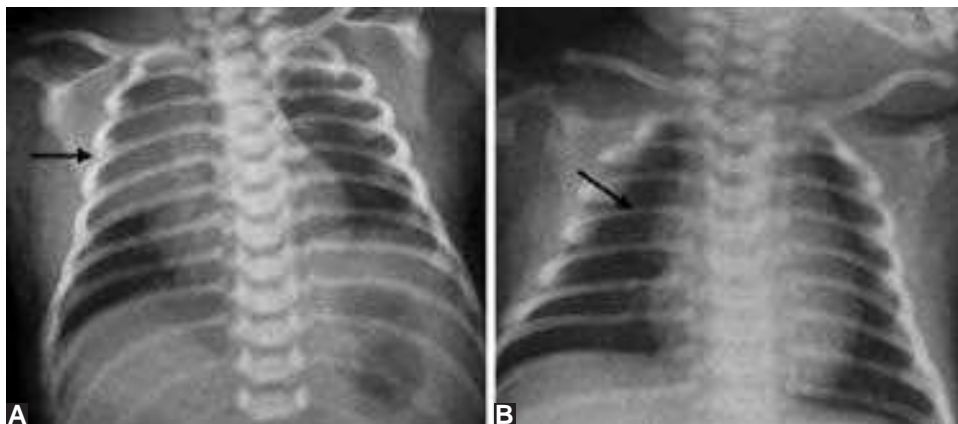


**Fig. 32.31:** CXR showing a soft tissue mass in the right hemithorax (black arrow) and multiple segmentation anomalies of the thoracic spine (white arrow). Differentials include a large intrathoracic meningocele

### A CHILD WITH A MEDIASTINAL MASS

#### Normal Thymus

The thymus gland is found in the anterior mediastinum and can have a variety of appearances. The 2 lobes of the thymus are often dense enough to obscure the upper and middle mediastinum. A thymus is recognised by its wavy margin from indentation by the ribs, by a sail configuration and by a notch where the thymic shadow intersects the cardiac margin.



**Figs 32.32A and B:** Radiographs of neonates showing a prominent normal thymus exhibiting the 'sail sign' (arrow in A) or the wave sign (arrow in B). It is often difficult to ascertain true heart size on the frontal radiograph. Mass effect or mediastinal shift is almost never seen with a normal thymus

A normal thymus can be a notorious source of difficulty when interpreting chest films. Sonography can be useful in thymic imaging especially to determine if the anterior mediastinal mass is a normal thymus.

### Thymic Sonography

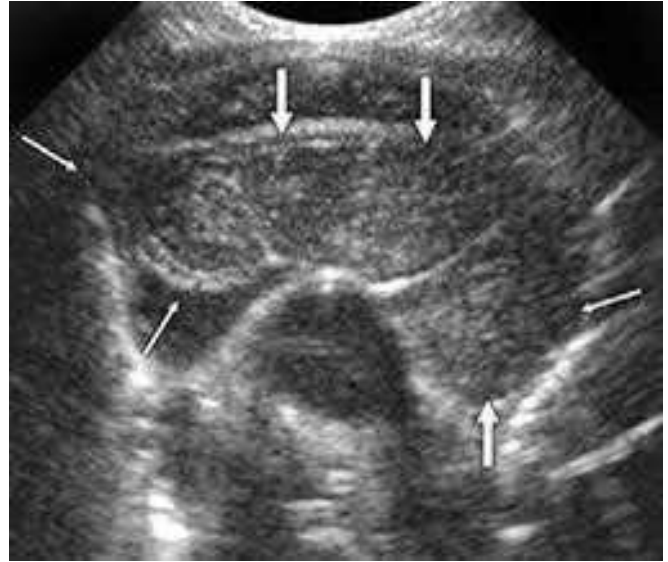
Sonographically the thymus has an echotexture similar to liver with punctuate echoes and echogenic lines. Real time sonography demonstrates normal thymic malleability during the respiratory cycle, helping in differentiating from a thymic mass. In the setting of a mass presence of cysts, calcification or heterogeneity of architecture can suggest thymic pathology.

### Lymphoma

Thymic involvement with lymphoma (Hodgkins and non-Hodgkins) can be multifocal or diffuse. With lymphoma, the age of the child and presence of other regions of adenopathy can be helpful in prioritising histology. If the lymphoma is confined to the thymus in an older child or adolescent, a Hodgkin's type lymphoma is likely. Non-Hodgkin's lymphoma can occur at any age. On CT, the appearances can be homogenous or heterogenous with areas of fibrosis, necrosis.

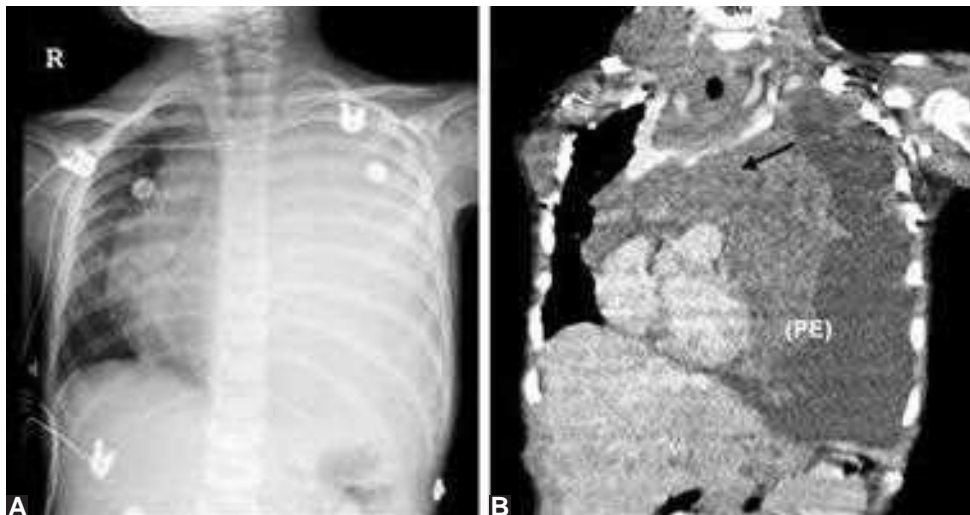
### Germ Cell Tumours

These tumours include teratomas, seminomas, dysgerminomas and choriocarcinomas. Second to lymphoma as a cause of mediastinal mass, most are located in the superior



**Fig. 32.33:** Axial ultrasound of the thymus at the level of ascending aorta (AA). The normal thymus (arrows) can have a bilobed appearance, homogenous texture and some echogenic strands

mediastinum and can be asymptomatic in up to half of the patients. Large tumours can cause tracheal and superior vena caval compression and are malignant in up to 10% of cases. Teratomas are the most common germ cell tumours and consist of ectodermal, mesenchymal and endodermal derivatives. On CT/MR they contain variable amounts of fat, calcium or soft tissue. Fat or calcium in an anterior mediastinal mass almost always indicates a germ cell tumour.



**Figs 32.34A and B:** CXR (A) and coronal reconstruction of a CT scan; (B) of a 5-year-old showing a large mediastinal mass (arrow) midline shift and a left pleural effusion (PE). Diagnosis at biopsy was of a T-cell lymphoma



**Fig. 32.35:** Mixed attenuation mass in the anterior mediastinum containing low attenuation areas representing fat (seen as low attenuation areas, arrow), in a child with chronic stridor from was airway compression



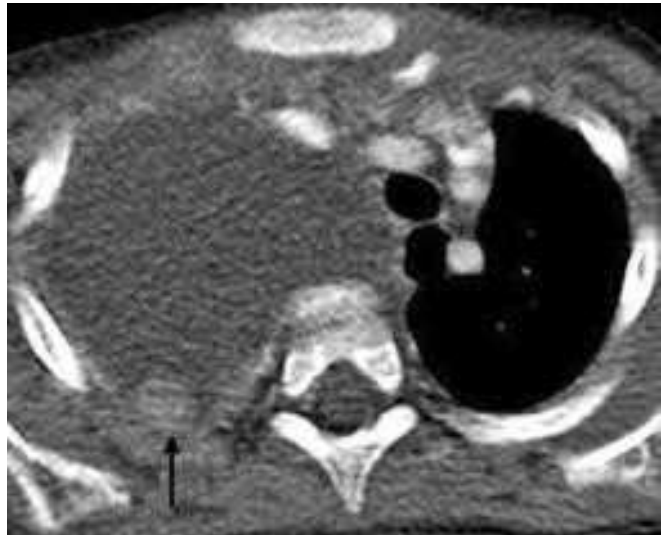
**Fig. 32.36:** CT scan in another patient with stridor shows a calcified anterior mediastinal mass (white arrow). The low attenuation areas within the mass represent fat

### Metastases

Most paediatric malignant tumours are pulmonary metastases, usually found during staging of a known or a new malignancy. Common paediatric tumours associated with lung metastases include Wilms' tumour, rhabdomyosarcoma, hepatoblastoma, Ewing's and osteosarcoma. CT is more sensitive than plain films in detecting metastases.



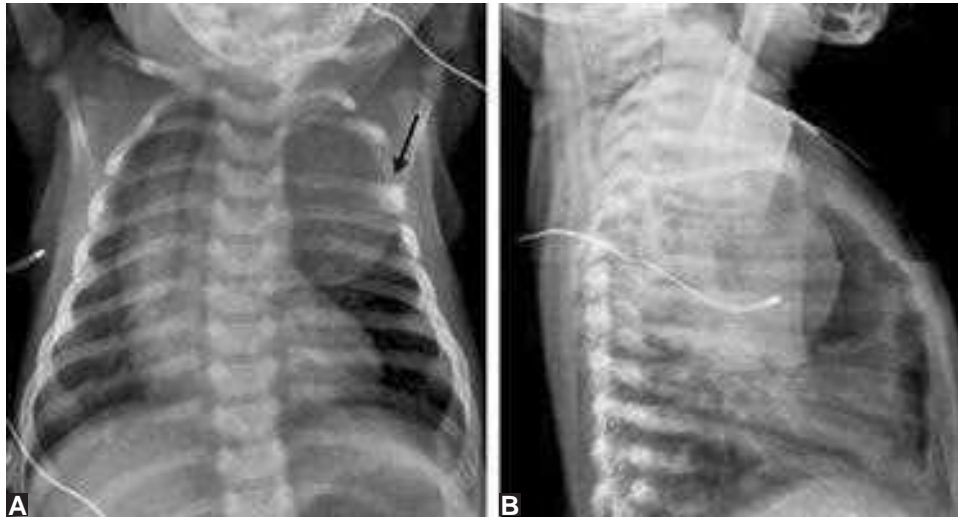
**Fig. 32.37:** Multiple intrapulmonary metastases from hepatoblastoma



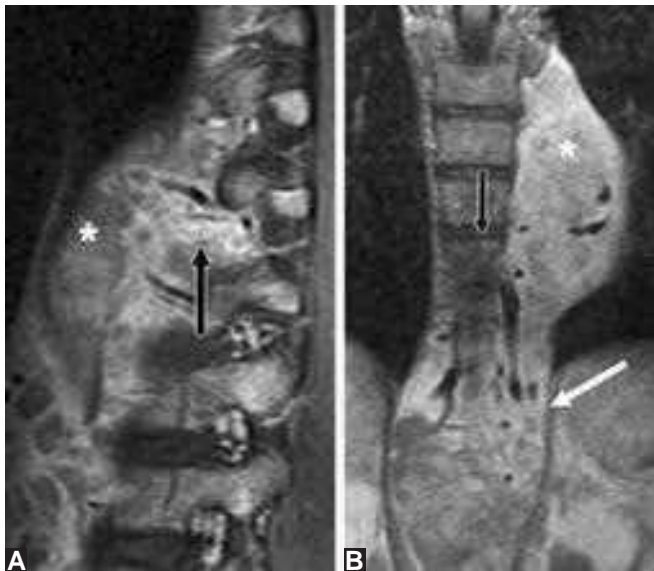
**Fig. 32.38:** Pleural based metastases (arrow) and effusion in a patient with Wilms' tumour

### Neuroblastoma

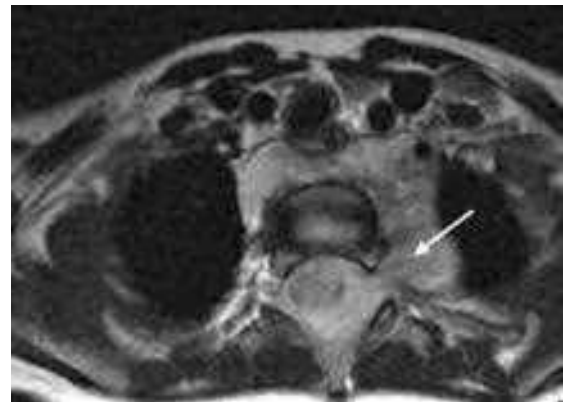
Majority of posterior mediastinal masses in children are of neurogenic origin, namely neuroblastoma, ganglioneuroblastoma and ganglioneuroma. Thoracic neuroblastoma has a better prognosis than abdominal neuroblastoma. The plain film suggests the diagnosis with posterior rib erosion and a mass, which may have some calcification. At CT most tumours are well circumscribed fusiform masses in the paraspinal location. Enlargement of the intervertebral neural foramina and spread into the abdomen via the aortic or oesophageal hiatus may be evident.



**Figs 32.39A and B:** (A) AP and lateral; (B) CXR in a child showing a well-defined left posterior mediastinal mass (arrow) with erosion, splaying and thinning of the posterior ribs



**Figs 32.40A and B:** (A) Sagittal and coronal; (B) MR images show a left paraspinal mass (asterisk) with extension into the intervertebral foramina (black arrows) and into the abdomen via the aortic hiatus (white arrow)



**Fig. 32.41:** Axial MR in a 6-year-old child showing a well-defined left paravertebral mass with extension into the intervertebral foramen (arrow)



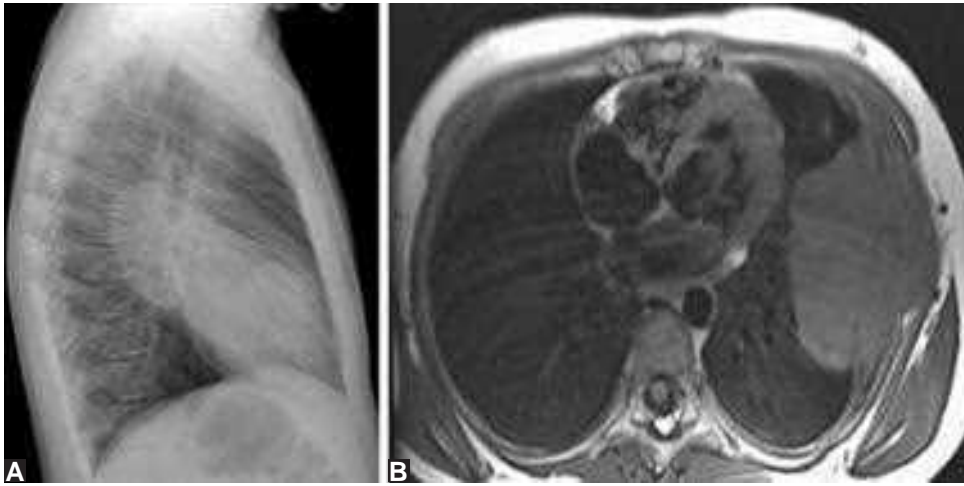
**Fig. 32.42:** Calcified neuroblastoma in the right paravertebral area (arrow) in 6 months old infant

## CHEST WALL MASSES

### Ewing Sarcoma

Ewing sarcoma is a malignant round cell tumour and is the most common malignant chest wall mass in children. It usually manifests as a peripheral chest wall mass with or without rib destruction. The CXR will show a mass with intrathoracic growth, rib and chest wall involvement and accompanying pleural effusion. MRI and CT play complimentary roles in staging these tumours.





**Figs 32.43A and B:** (A) Lateral CXR and T1-weighted MR; (B) showing a left chest wall mass following the rib contours and extending into the thoracic cavity

### Rhabdomyosarcoma

Rhabdomyosarcoma is the most common extrapleural chest wall tumour in children. The radiologic features are difficult to distinguish from Ewing sarcoma.

### Osteochondroma of the Ribs

Most common benign tumour of the chest wall, composed of cortical and medullary bone with a cartilaginous cap and usually continuous with the underlying bone.

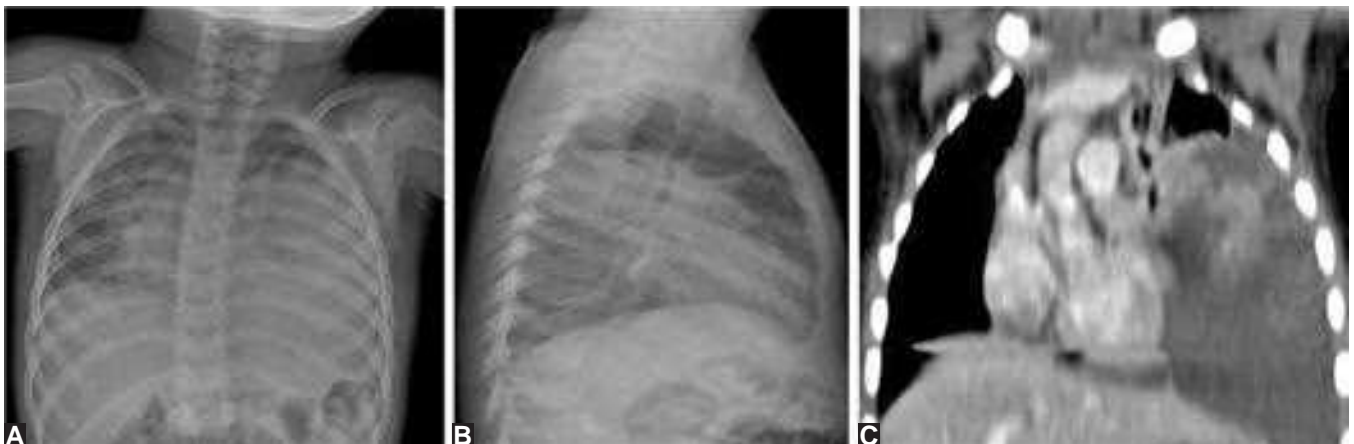
## CONGENITAL HEART DISEASE

Imaging approach:

1. Echocardiography
2. Chest radiography
3. Cardiac catheterisation
4. MRI



**Fig. 32.45:** Oblique view of the ribs shows bony lesion attaches to the ribs by a broad base (arrow)



**Figs 32.44A to C:** (A) AP and lateral; (B) CXR showing a left chest soft tissue mass and mediastinal shift. Coronal CT; (C) reconstruction shows a mixed density mass with fluid and solid components. These appearances may be confused with empyema

## Specific Chamber Enlargement on Plain Film

### Right Atrium



**Fig. 32.46:** The enlarged right atrium displaces the right heart border to the right, and increased curvature of the right heart border. A step like angle (white arrow) between the right atrium and the superior vena cava may be seen

### Right Ventricle



**Fig. 32.47:** The right ventricle occupies the front of the heart and is non-border forming in the frontal view. Enlargement of the right ventricle results in tilting up and posterior displacement of the left ventricle and a triangular configuration of the heart and elevation of the apex (block arrow)

### Left Atrium



**Fig. 32.48:** An enlarging left atrium may elevate the left main bronchus, and cause a bulge in the right heart border producing a double shadow seen through the right heart border. Particularly in rheumatic heart disease there may be left atrial enlargement seen as a discrete bulge on the left heart border below the pulmonary bay

### Left Ventricle



**Fig. 32.49:** The left ventricle forms the left border and the apex of the cardiac shadow on a frontal CXR. Enlargement leads to rounding of the apex of the heart and elongation of long axis of the left ventricle (arrow)

## Acyanotic Child with Congenital Heart Disease

Left to right shunts account for about half of all forms of congenital heart disease.

Three common diagnoses include.

1. Patent ductus arteriosus (PDA)
2. Ventricular septal defect (VSD)
3. Atrial septal defect (ASD)

### Ventricular Septal Defect

Ventricular septal defect (VSD) is the most common congenital cardiac anomaly, usually presenting in infants and toddlers. It may be isolated or associated with other congenital defects. Defects can occur in any part of the interventricular septum: Peri-membranous, muscular or trabecular, outlet or inlet. The haemodynamics of the VSD are determined by the size of the defect and the pressure difference between the left and right ventricle. In neonates with a high pulmonary vascular resistance significant left to right shunting is uncommon but in large defects congestive heart failure develops at 1–3 months of age due to normal decrease in pulmonary vascular resistance. The CXR in a VSD with a small left to right shunt is normal. In large shunts the main, branch and the intrapulmonary branches of the pulmonary arteries dilate. There is enlargement of the left atrium and the ventricles.



**Fig. 32.50:** Chest radiograph showing cardiomegaly, biventricular enlargement and increased lung vascularity

### Patent Ductus Arteriosus

The ductus arteriosus extends from the origin of the left pulmonary artery to the descending aorta just beyond the origin of the left subclavian artery and shunts blood from the main pulmonary artery to the aorta. In new-borns the PDA is a common cause of congestive heart failure. Small premature infants with a PDA and a left to right shunt may have evidence of left ventricular failure. Patients with small PDA have no radiographic abnormalities. Large PDAs show increased lung vascularity and enlarged left atrium and ventricle.



**Fig. 32.51:** Chest radiograph showing marked cardiomegaly with left ventricular enlargement (downward pointing apex, arrow), left atrial enlargement resulting in carinal splaying and areas of atelectasis interspersed with hyperinflation, and pulmonary oedema in a patient with a large PDA. Atelectasis is due to a large left atrium compressing the airways

### Atrial Septal Defect

Atrial septal defect (ASD) is commonly an isolated lesion. The shunt is from the left to the right atrium leading to enlargement of the right atrium, ventricle and the pulmonary arteries. Most children are asymptomatic and are usually diagnosed in older children or adults. The condition is usually undetected until a murmur is heard. A moderate sized ASD shows increased lung vascularity, an enlarged heart with prominent right atrium and pulmonary artery. Right ventricular filling may be seen as filling of the retrosternal space on a lateral CXR.



**Fig 32.52:** CXR showing enlarged right atrium and right ventricle (shown as filling of the retrosternal space on a lateral CXR, asterisk) main pulmonary artery (arrow) with increased pulmonary flow

## CYANOTIC CHILD WITH CONGENITAL HEART DISEASE

Common causes include Tetralogy of Fallot (TOF), transposition of great vessels and pulmonary atresia with intact ventricular septum.

### Tetralogy of Fallot

TOF is the most common cyanotic congenital cardiac disease in children. The four components of TOF are: Right ventricular outflow tract (RVOT) obstruction, subaortic VSD, over-riding aorta and right ventricular hypertrophy. The severity of RVOT obstruction determines the amount of left to right shunting across the VSD. The infundibular stenosis progresses with age and left to right shunting increases proportionately. The CXR shows a mild to moderate cardiomegaly, uplifted apex secondary to right ventricular enlargement and concavity in



**Fig. 32.53:** CXR showing a 'boot shaped heart', due to elevation of the apex secondary to right ventricular hypertrophy, right aortic arch (arrow) and pulmonary oligemia

the region of pulmonary artery segment giving a boot shaped heart. A right-sided aortic arch occurs in 25% of patients with TOF.

### D-Transposition of Great Vessels

Transposition of great vessels (d-TGV) is the most common congenital cardiac disorder causing cyanosis in the first 24 hours of life. The aorta and the pulmonary artery are transposed. The ascending aorta arises from the right ventricle and the pulmonary artery rises from the left ventricle giving two parallel circuits between the pulmonary and systemic circulations. Communications between the two circulations are vital for survival and include PDA, ASD and VSD. The CXR shows a narrow superior mediastinum due to decrease in thymic tissue and abnormal relations of the great vessels and lack of visualisation of the aortic arch which is mal-positioned and lack of normal shadow of the main pulmonary artery. The lung vascularity can be increased, decreased or normal.

### Pulmonary Atresia with Ventricular Septal Defect

There is severe hypoplasia or atresia of the main pulmonary artery leading to no forward flow from the right ventricle into the lungs. Blood supply to the lungs is usually via collaterals from the aorta. Most infants are hypoxic and cyanotic. Radiologically the heart is enlarged with an upturned apex secondary to right ventricular hypertrophy. There is marked concavity in the region of the main pulmonary artery because of under-development of the infundibulum and the main pulmonary artery. Pulmonary vascular markings have an unusual reticular appearance due to abnormal.



**Fig. 32.54:** (d-TGV). Newborn with marked cyanosis. The heart is enlarged and there is a narrow superior mediastinum (arrow). The pulmonary vascularity is increased despite an inconspicuous main pulmonary artery segment

## Truncus Arteriosus

An uncommon anomaly, truncus arteriosus is due to failure of division of the primitive truncus into the aorta and pulmonary artery. One large vessel originates from the heart to supply the systemic, pulmonary and coronary circulations. A large VSD is always present. Several types of truncus are described. Radiologically, cardiomegaly and increased



**Fig. 32.55:** Pulmonary atresia with VSD. Cardiomegaly with a markedly elevated apex, concavity in the region of the main pulmonary artery (arrow) and a right aortic arch with abnormal lung vascularity



**Fig. 32.56:** Contrast enhanced magnetic resonance angiography (MRA) shows multiple aortopulmonary collateral arteries (arrows) supplying the lungs



**Fig. 32.57:** A 2-month-old boy with cyanosis. The heart is enlarged, the main pulmonary artery segment is concave and the pulmonary vascularity is increased

pulmonary flow are seen at birth in a cyanosed infant. There is enlargement of the left atrium, pulmonary oedema and a prominent truncus. The main pulmonary artery segment is concave. The aorta is right sided in one third of patients.

## Total Anomalous Pulmonary Venous Drainage

Total anomalous pulmonary venous drainage (TAPVD) occurs when the common pulmonary vein fails to develop and the branch pulmonary veins connect to other venous structures such as superior vena cava (SVC), IVC, right atrium, or portal venous system. TAPVD is divided into four types: Supra cardiac, cardiac, infracardiac and mixed. The supracardiac type is the most common. All four pulmonary veins converge into a left vertical, which drains into the left innominate vein. Because both systemic and pulmonary veins drain into the right atrium there is increased volume overload of the right heart, which enlarges. Radiologically, the appearance of the mediastinum is likened to a snow man with the upper half of the 'snowman' consisting of the vertical vein and the dilated SVC.

## OTHER CARDIAC AND RELATED CONDITIONS

### Coarctation of Aorta

Coarctation of aorta (CoA) results from membranous infolding of the posterolateral wall of the thoracic aorta at the level of ligamentum or ductus arteriosus causing obstruction to forward blood flow. Poststenotic dilatation of the proximal descending thoracic aorta is present. Significant coarctation impairs blood flow into the descending thoracic aorta

necessitating the presence of collaterals to re-establish blood flow. The intercostal arteries are major collaterals resulting in rib notching along the inferior surface of 3–8th ribs in untreated patients usually by 10 years. Other collaterals arise from internal mammary, lateral thoracic and epigastric arteries. On a frontal CXR one can identify a high aortic arch, a reverse '3' indentation at the site of coarctation (reflecting pre-coarctation dilatation, the coarctation and



**Fig. 32.58:** CXR in a 14-year-old patient with a late diagnosis of coarctation shows a high aortic arch (black arrow), a reverse appearance at the coarctation site (white arrow), rib notching (small arrows) and left ventricular hypertrophy



**Fig. 32.59:** Contrast enhanced MRA of the aorta demonstrates the tight coarctation (arrow) and intercostal, internal mammary and lateral thoracic collaterals



**Fig. 32.60:** Post-balloon angioplasty of another patient with coarctation shows resolution of the stenosis with a small intimal flap from dissection (arrow)

postcoarctation dilatation and rib notching. The coarctation can be well demonstrated by MRA.

### Ebstein's Anomaly

An uncommon congenital abnormality in which the septal and posterior leaflets of the tricuspid valve are attached to the wall of the middle of the right ventricular chamber instead of the valve ring. This results in mild to gross tricuspid regurgitation and marked right atrial enlargement. The foramen ovale is patent and the raised right atrial pressure results in right to left shunt and cyanosis. The frontal CXR shows an enlarged globular or square cardiac silhouette and reduced pulmonary vascularity.



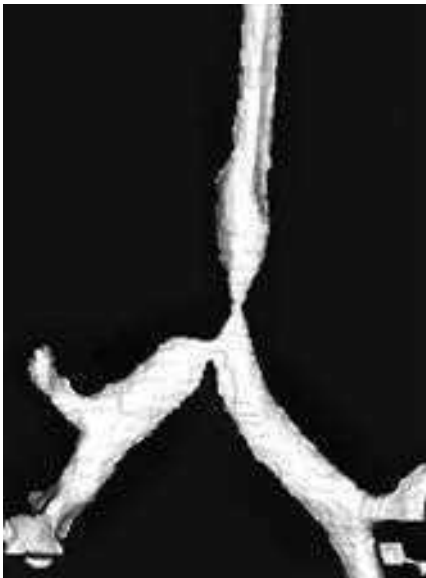
**Fig. 32.61:** CXR showing a globular cardiomegaly, enlarged right atrium and reduced lung vascularity

## Double Aortic Arch

In this type of anomaly the ascending aorta is anterior to the trachea bifurcating into two arches that pass to the sides of the trachea before joining posterior to the oesophagus to form the descending aorta. The double aortic arch forms a tight vascular ring that may present with severe stridor and requires surgical intervention.



**Fig. 32.62:** Three-dimensional reconstruction of a CT angiogram shows a double aortic arch (asterisks)



**Fig. 32.63:** Three-dimensional reconstruction of the airway in a patient with double aortic arch and stridor shows tight narrowing of the distal trachea by the complete vascular ring

## ABDOMEN

### A NEONATE WITH BILIOUS VOMITING

Common causes:

- Malrotation with or without small bowel volvulus
- Duodenal/small bowel atresias and webs
- Meconium ileus.

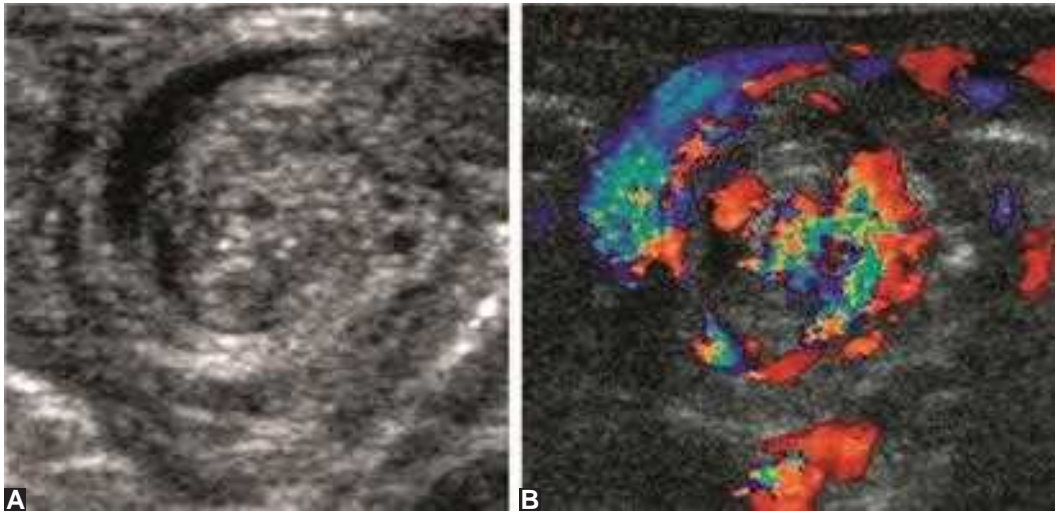
#### Malrotation

Malrotation is a general term for any abnormal variation in intestinal rotation. Any variety of malrotation seen in a child with abdominal symptoms should be assumed to be the cause of the symptoms unless proven otherwise. Malrotation of the intestines is accompanied by malfixation of the mesenteric root, which can have catastrophic consequences. The duodenal junction and the ileocaecal junctions are normal points of fixation of the mesentery, which has a broad base and unlikely to twist. When these points of fixation are not in their usual location the mesentery has a narrow base and there is a tendency for the intestines to twist around it. Abnormal peritoneal bands, Ladd's bands frequently accompany malrotation and can cause duodenal obstruction. Patients with malrotation can present at any age with bilious vomiting but most patients with symptomatic malrotation present in the first month of life.

Radiological investigations should include a plain film of the abdomen, which may show duodenal obstruction and an upper gastrointestinal studies which demonstrate malfixation of bowel, namely malposition of the duodenojejunal flexure (more accurate indicator of malrotation) and the caecum.



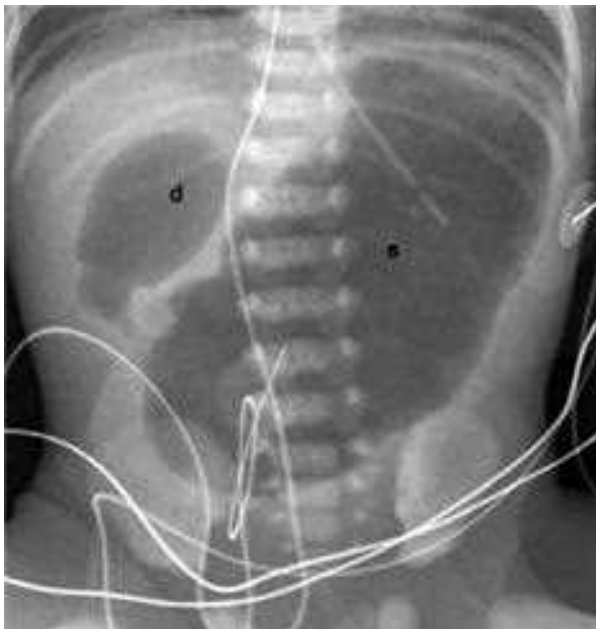
**Fig. 32.64:** Upper GI contrast exam in a newborn baby with bilious vomiting shows malrotation of the small bowel with the duodenojejunal flexure and jejunal loops lying to the right of the spine (arrow)



**Figs 32.65A and B:** Malrotation with volvulus in another patient: Sonography with colour Doppler shows (A) a 'whirlpool' appearance of the volved small bowel and; (B) Twisting of the superior mesenteric artery and vein

### Duodenal Atresia

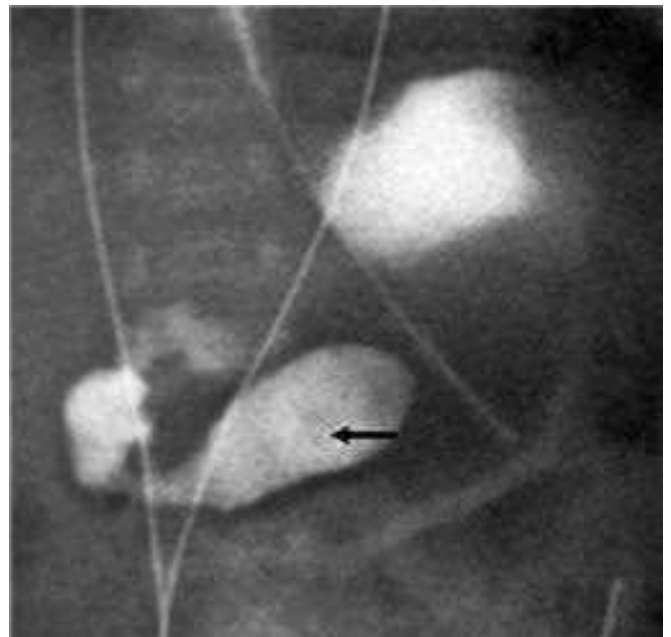
Infants with duodenal atresia (DA) present with bilious vomiting in the first few hours of life. The obstruction is usually below the ampulla of Vater. Plain abdominal film shows a characteristic double bubble sign. Once this pattern is seen there is no need for further contrast studies. DA is commoner in infants with trisomy 21.



**Fig. 32.66:** Abdominal film in a neonate with bilious vomiting showing a 'double bubble' appearance in DA due to a dilated stomach (s) and first part of duodenum (d). No air is present distal to the stomach

### Duodenal Diaphragm

Duodenal diaphragms usually occur in the descending portion of the duodenum and frequently the common bile duct is incorporated in the diaphragm. Vomiting is bile stained and plain abdominal films show obstruction at the level of descending duodenum. Definitive diagnosis is usually made with barium studies.

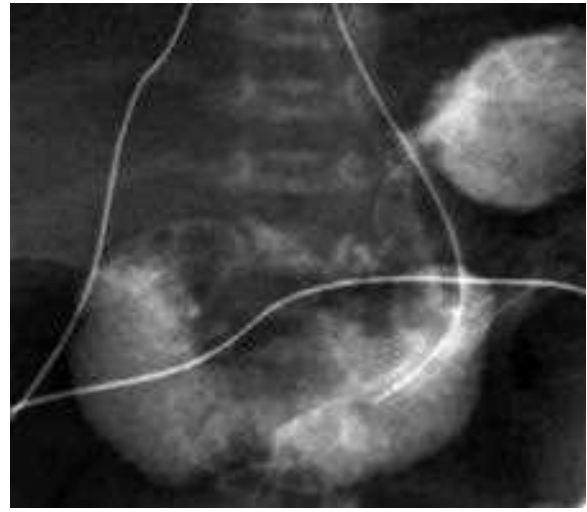


**Fig. 32.67:** Upper gastrointestinal contrast study in a newborn with bilious vomiting shows the duodenal diaphragm (arrow)





**Fig. 32.68:** Upper abdominal ultrasound in a neonate showing dilated and fluid filled first (1) and second (2) parts of the duodenum due to a web (arrow)



**Fig. 32.70:** Water-soluble contrast study showing a dilated duodenum and failure of passage of contrast beyond the duodenal jejunal flexure in proximal jejunal atresia

### Small Bowel Atresia

Small bowel atresia presents with abdominal distension and bilious vomiting condition is often not diagnosed until laparotomy. Radiographs show one or two dilated small bowel loops if the obstruction involves jejunum. If distal small bowel is involved multiple dilated loops of small bowel is seen with air fluid levels. A contrast enema is then necessary to assess for colonic obstruction.



**Fig. 32.69:** Plain radiograph in an infant with jejunal atresia showing dilatation of proximal bowel loops

### Meconium Ileus

Usually it is considered as a manifestation of CF in neonates. Obstruction results from impaction of thick tenacious meconium in the distal small bowel and complications such as ileal atresia, stenosis, ileal perforation, meconium peritonitis and volvulus with or without pseudocyst formation are common. Infants present with bile stained vomiting, abdominal distension and failure to pass meconium. Plain films show low small bowel obstruction with marked small bowel dilatation. Air fluid levels are generally absent due to tenacious mucous. A contrast enema demonstrates a micro colon. The enema can also be therapeutic.



**Fig. 32.71:** Abdominal film in an infant with meconium ileus shows marked small bowel dilatation



Fig. 32.72: A contrast enema shows a microcolon

## OTHER ABDOMINAL CONDITIONS IN CHILDREN

### Hypertrophic Pyloric Stenosis

Hypertrophic pyloric stenosis (HPS) is a common condition presenting between 2 to 6 weeks of life in predominantly male infants with non-bilious projectile vomiting. Severe cases also have weight loss and metabolic alkalosis of varying severity with potassium depletion. A small firm mass the pseudotumour of HPS may be palpable. Sonography is the modality of choice to diagnose HPS. The stomach is emptied prior to exam by inserting a nasogastric tube and aspirating the contents. Sterile water is then introduced under sonographic guidance. HPS is seen as enlarged hypoechoic



Figs 32.73A and B: (A) US showing an enlarged pylorus with hypoechoic muscle (arrow). Water introduced through a nasogastric tube is seen in the antrum (asterisk); (B) plain abdominal film showing a distended stomach (s)

pyloric musculature with minimal emptying of the water into the duodenum. A plain film done to assess for other causes of vomiting may show gaseous distension of the stomach with little gas distally.

### Acute Appendicitis

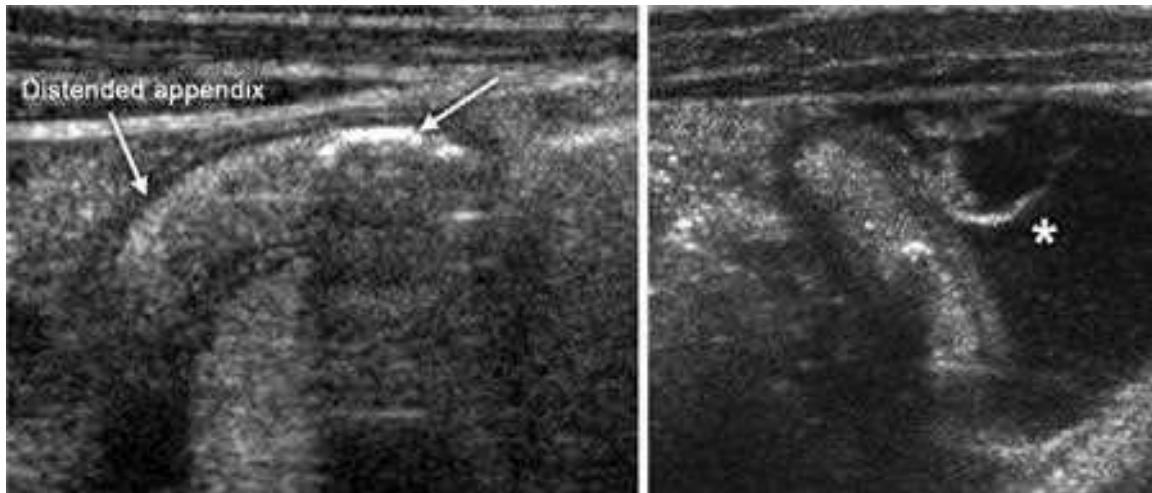
Acute appendicitis is the most common indication for emergency abdominal surgery in children. It is caused by obstruction to the appendiceal lumen commonly by a faecalith. The appendix distends with secondary bacterial inflammation, oedema and vascular engorgement. Compromised blood supply may produce necrosis, gangrene and perforation with



Fig. 32.74: Plain abdominal film shows a calcified faecalith (arrow) in the right iliac fossa and small bowel dilatation in a patient with appendicitis



Figs 32.75A and B: Appendicitis with obstruction: (A) Supine view of the abdomen shows small bowel dilatation and a gasless right iliac fossa; (B) Erect view demonstrates air-fluid levels in the small bowel



**Fig. 32.76:** Ultrasound of a patient with complicated appendicitis shows a distended appendix with a phlebolith (arrow). The phlebolith is seen as an echogenic curvilinear structure with posterior acoustic shadowing. There is a focal fluid collection near the appendix (asterisk)



**Fig. 32.77:** Sagittal reconstruction of a CT scan of the abdomen in a patient with complicated appendicitis shows a thick walled abscess (arrow) which was successfully drained transrectally

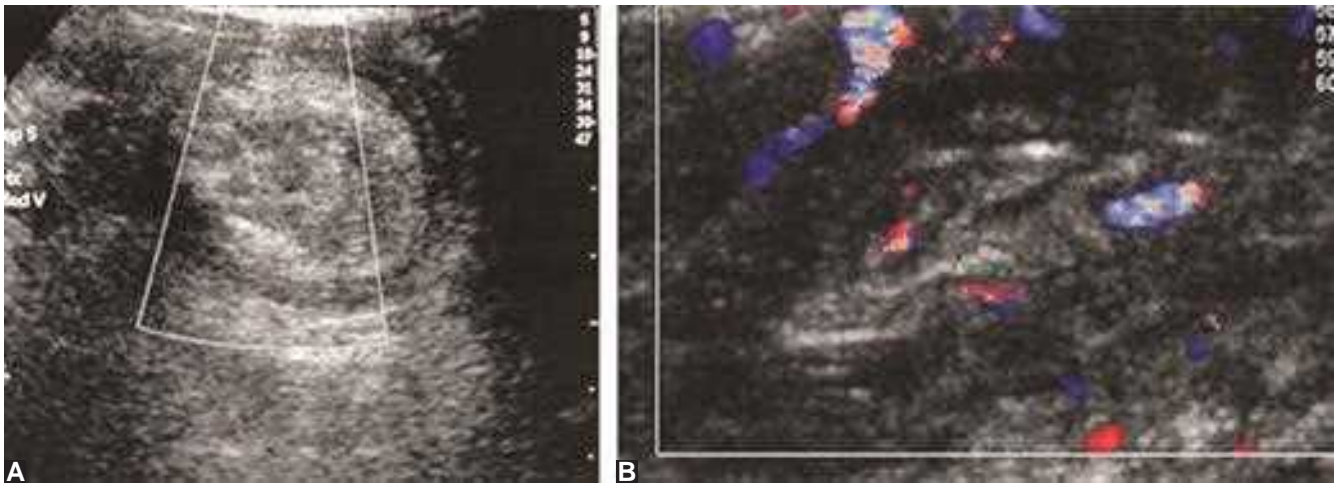
peritonitis. Complicated peritonitis can lead to a local walled off abscess or multiple intraabdominal abscesses. Plain abdominal films may be normal or demonstrate a gasless right iliac fossa and a calcified faecalith. Complicated cases may present with small bowel obstruction from the complex appendiceal mass with comprises of the inflamed appendix; adjacent loops of small bowel and inflamed mesentery. Sonography shows the inflamed appendix, abscess and the complex right lower quadrant mass.

### Intussusception

Intussusception is the invagination of the proximal bowel into its distal lumen. Ileocolic intussusceptions are most common (90%) and may or may not have a lead point which include Meckel's diverticulum, polyps, lymphoma or submucosal haemorrhage. Most intussusceptions are idiopathic and the clinical symptoms include intermittent abdominal pain, vomiting, bloody stools and palpable abdominal mass. The plain film is normal in 25% of patients or may show soft tissue mass or small bowel obstruction. Ultrasound helps in



**Fig 32.78:** Abdominal radiograph in a patient with typical clinical features of an intussusception shows a soft tissue mass in the right upper quadrant (black arrows)



**Figs 32.79A and B:** Ultrasound shows (A) concentric hypo and hyperechoic layers in the intussusception and; (B) A pseudokidney sign with preserved blood supply on colour Doppler

the diagnosis and shows a mass with alternating hypo and hyperechoic concentric rings axially and a 'pseudokidney sign' longitudinally.

Depending on the sonographic appearances and clinical state of the patient radiological reduction using air is attempted.

### Abdominal Trauma

Abdominal trauma in children can be penetrating or blunt. Blunt trauma is commoner in children and can cause solid

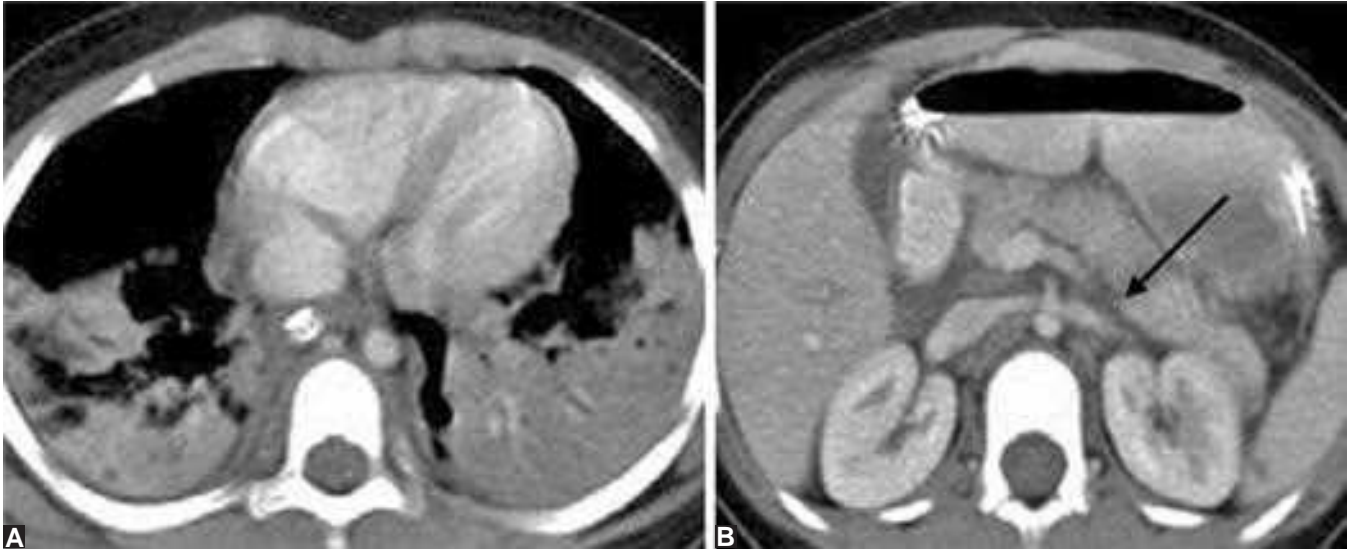
organ or bowel trauma. Various types of solid organ injuries like liver fractures and contusions, splenic fractures, pancreatic and renal injuries can occur. Bowel trauma with contusion and perforation can also occur. The main modality for investigating these surgical emergencies is CT scanning which should be done with intravenous and gut contrast enhancement as far as possible. Associated lung trauma like contusions, pneumothoraces and rib fractures may occur. Vertebral injuries like Chance fractures may also occur.



**Fig 32.80:** Air enema reduction shows the intussusception reduced to the cecum (arrow)



**Fig. 32.81:** CT scan of a child following a fall from a height shows a fracture of the right lobe of the liver (arrow)



**Figs 32.82A and B:** CT scan of a child with blunt trauma shows (A) Bilateral lung contusions; (B) Pancreatic fracture (arrow)



**Fig. 32.83:** Renal trauma: CT scan shows a left renal fracture and contusion with perirenal fluid (arrow). Note the normal right kidney



**Fig. 32.84:** Splenic fracture (arrow) seen in a 7-year-old after fall from a horse



**Fig. 32.85:** Jejunal contusion (arrow) and free fluid (FF) in the left flank in a patient with blunt trauma to the abdomen from fall from a tree

## THE CHILD WITH AN ABDOMINAL MASS

Common masses include:

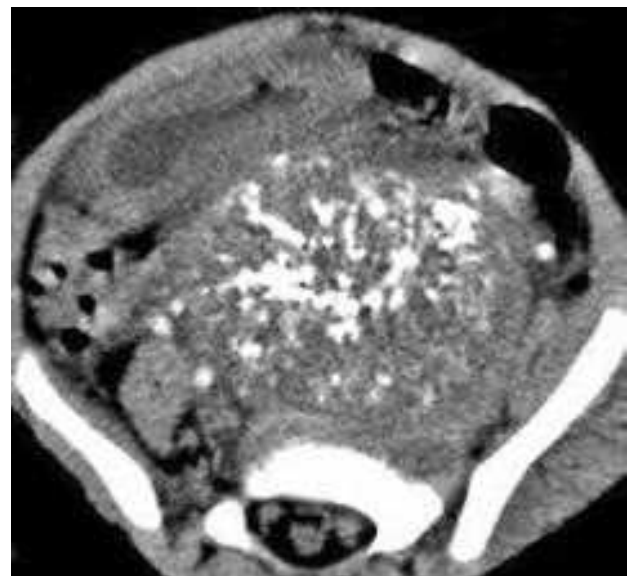
- Neuroblastoma
- Wilms' tumour
- Multicystic dysplastic kidney (MCDK)
- Hepatoblastoma
- Pelviureteric junction obstruction (PUJ)
- Lymphoma.

The differential diagnosis varies according to the age. An abdominal mass in the newborn is most commonly benign and of renal origin (neonatal hydronephrosis due to various causes). Renal neoplasms are unusual in this group but occasionally mesoblastic nephroma may be seen. Other masses include renal enlargement due to renal vein thrombosis, adrenal haemorrhage, bowel related masses and sacrococcygeal teratoma. In infants and young children the retroperitoneal masses are common. These include neuroblastomas and Wilms' tumour. Other masses include hepatoblastomas, lymphomas, teratomas and lymphangiomas.

### Abdominal Neuroblastoma

Most common extracranial solid tumour of childhood, and accounts for 10% of all paediatric neoplasms. Presentation is commonly with an abdominal mass. Other modes of presentation include cord compression, constipation, or as a paraneoplastic syndrome. Two of these syndromes are recognised, namely the opsoclonus myoclonus syndrome and the watery diarrhoea, hypokalaemia and achlorhydria syndrome. Radiological evaluation begins with a plain film, which shows a mass with calcification. Sonography shows

a tumour, which is in homogenous, echogenic and a poorly defined extrarenal mass. Hypoechoic regions may be due to haemorrhage, necrosis or cyst formation. Areas of calcification are echogenic. CT scanning accurately stages the tumour and demonstrates the primary tumour, contiguous spread, vascular encasement retroperitoneal lymphadenopathy and liver metastases. MRI is the imaging modality of choice and is superior in imaging adenopathy, vascular involvement, bone marrow metastases and intraspinal extension.



**Fig. 32.86:** Neuroblastoma: CT scan showing a calcified lower abdominal mass with presacral lymphadenopathy



**Fig. 32.87:** Neuroblastoma: 2 years old with neuroblastoma. An enhanced CT image shows a retroperitoneal mass with vascular encasement (arrows)



**Fig. 32.89:** Left sided Wilms' tumour (same patient as above). Coronal CT reconstruction shows a mixed density mass containing areas of necrosis and cysts

### Wilms' Tumour

Wilms' tumour is the most common renal tumour of childhood and presents mostly as an asymptomatic abdominal mass. Other symptoms include abdominal pain and haematuria. Plain abdominal radiography shows a soft tissue mass with calcification in about 5%. Sonography shows an intrarenal mass which is hyperechoic compared to normal renal parenchyma with areas of necrosis and cysts. Renal vein



**Fig. 32.88:** Left sided Wilms' tumour. Plain abdominal radiograph shows a left side soft tissue mass (arrow)



**Fig. 32.90:** Right side Wilms' tumour: Coronal MRI shows a large right sided mass containing areas of cystic degeneration

and inferior caval invasion occurs in 15%. CT scan shows a well-defined intrarenal mass distorting the collecting system and with inhomogeneous enhancement postcontrast. MRI is better than CT in the evaluation of the intrarenal mass, assessment of perinephric extension, contra lateral kidney and evaluation of the renal vein and IVC.



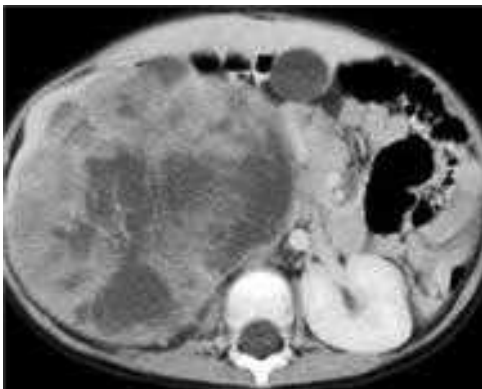
**Fig. 32.91:** Lung metastases from a Wilms' tumour. CT image showing a large right sided lung metastasis (arrow)

### Congenital Mesoblastic Nephroma

Most common renal tumour of neonates and the pathologic spectrum ranges from benign congenital mesoblastic nephroma to malignant spindle cell sarcoma. Plain radiographs show a soft tissue mass. Sonographically the mass is well-defined and hypoechoic or hyperechoic. CT demonstrates the intrarenal location of the mass.



**Fig. 32.92:** Mesoblastic nephroma: US shows a hyperechoic mass containing cysts in a newborn



**Fig. 32.93:** Mesoblastic nephroma (same patient as above). CT image shows a right renal mass of mixed attenuation

### Hepatoblastoma

Primary liver tumours account for 15% of abdominal neoplasms in children. Most children present with an asymptomatic abdominal mass. Others present with anorexia, weight loss, jaundice and pain. Alpha fetoprotein levels are raised in up to 90% of cases. Plain films reveal a soft tissue mass in the upper abdomen. Sonographically the lesion appears as a large, well-defined intrahepatic hyperechoic mass containing areas of cystic degeneration, necrosis and haemorrhage. Hepatic and portal venous invasion may occur. CT and MRI define the intrahepatic extent, extrahepatic spread and vascular invasion.



**Fig. 32.94:** Hepatoblastoma: Plain abdominal film shows a large upper abdominal soft tissue mass in a 3-month-old infant (arrows)

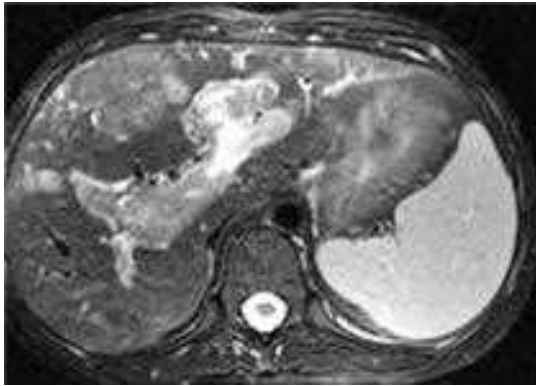


**Fig. 32.95:** Hepatoblastoma: US scan of a month old infant with an abdominal mass shows a large hyperechoic mass





**Fig. 32.96:** Hepatoblastoma: CT image shows a large well-defined in homogenous lobulated intrahepatic mass (arrows) with slightly lower attenuation and enhancement than the normal liver. Fibrous bands can be seen as unenhanced linear structures



**Fig. 32.97:** Hepatoblastoma with portal vein invasion: Axial MRI (T2-weighted) shows a distended portal venous confluence (arrows) and multiple tumour thrombi

### Burkitt Lymphoma



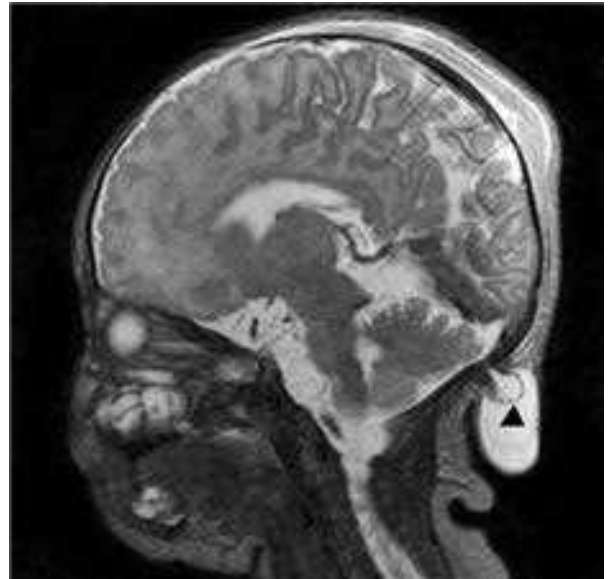
**Figs 32.98A and B:** Plain abdominal film (A) Showing upper abdominal fullness due to masses; (B) MRI showing diffuse bowel wall infiltration and a right renal mass (arrow)

## PAEDIATRIC NEURORADIOLOGY

### CONGENITAL BRAIN MALFORMATIONS

#### Cephalocele

A cephalocele is a defect in the skull and dura, through which intracranial structures (cerebrospinal fluid, meninges and brain tissue) can herniate. MRI is the study of choice for investigating this condition.



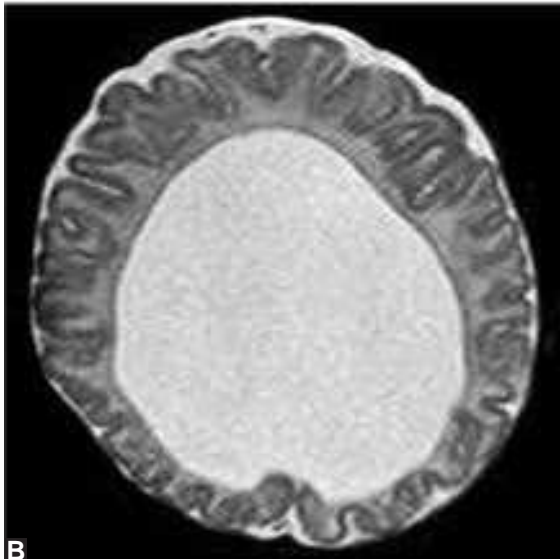
**Fig. 32.99:** Occipital cephalocele. Sagittal T2-weighted MR image shows a small occipital cephalocele with herniation of CSF and meninges (arrowhead)



**Fig. 32.100:** Occipital cephalocele. Sagittal T1-weighted MR image shows a large occipital cephalocele with herniation of cerebellar tissue (arrow) and CSF into the cephalocele

## HOLOPROSENCEPHALY

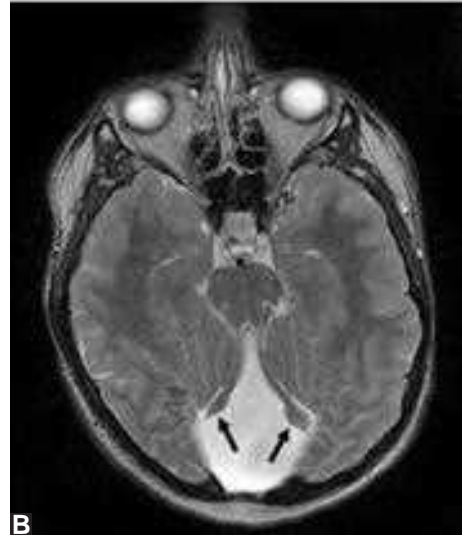
The holoprosencephalies are a group of disorders typified by failure of the embryonic forebrain (prosencephalon) to sufficiently divide into two cerebral hemispheres.



**Figs 32.101A and B:** Holoprosencephaly. (A) Coronal ultrasound scan shows a holovertricle due to absence of midline structures (septum pellucidum, corpus callosum and falx cerebri). The thalami (arrowheads) are fused in the midline; (B) Axial T2-weighted image shows a holovertricle

### Dandy-Walker Malformation

The Dandy-Walker malformation consists of complete or partial agenesis of the cerebellar vermis, an enlarged posterior cranial fossa and cystic dilatation of the fourth ventricle, which almost entirely fills the posterior cranial fossa.



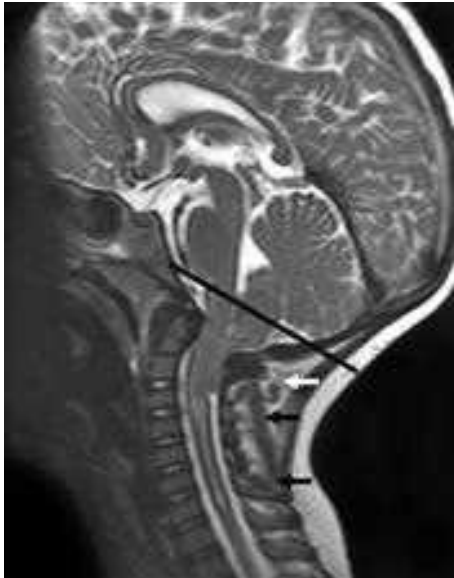
**Figs 32.102A and B:** Dandy-Walker malformation. (A) Sagittal T2-weighted MR image shows a markedly enlarged posterior fossa and cystic dilatation of the fourth ventricle; (B) Axial T2-weighted MR image shows the markedly hypoplastic cerebellar vermis (arrows)



**Fig. 32.103:** Dandy-Walker malformation. Sagittal T2 MR image shows enlarged posterior cranial fossa with mild hypoplasia of the cerebellar vermis (arrow)

### Chiari I Malformation

The Chiari I malformation is defined as caudal (downward) extension of the cerebellar tonsils below the foramen magnum. The cerebellar tonsils are elongated and pointed. There may be mild caudal displacement and flattening or kinking of the medulla. A syrinx is present in the spinal cord in up to 25% of patients.



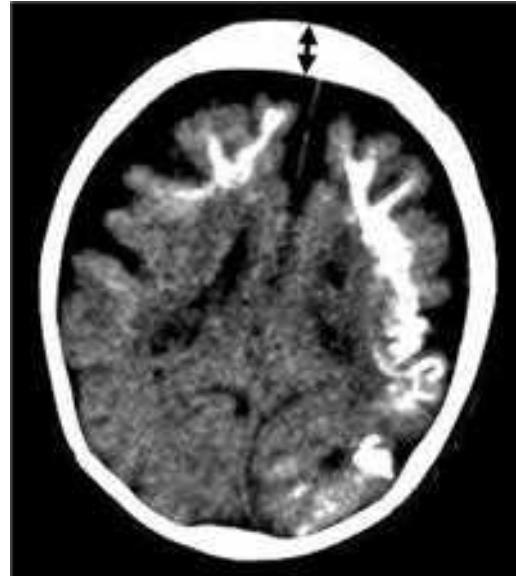
**Fig. 32.104:** Chiari I malformation on sagittal T2-weighted MR image. The cerebellar tonsil (white arrow) extends well below the foramen magnum (black line). The high signal within the cervical cord (arrowheads) indicates the presence of a syrinx



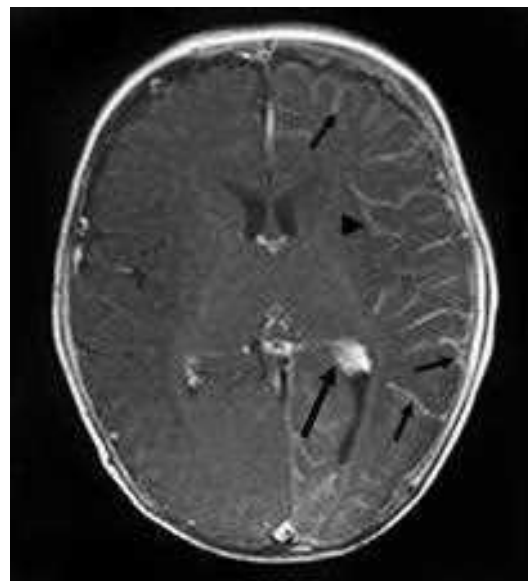
**Fig. 32.105:** Chiari I malformation. Sagittal T1-weighted MR image shows cerebellar tonsillar descent below the foramen magnum. There is a large syrinx in the cervical and thoracic spinal cord (arrows)

### Sturge-Weber Syndrome

The Sturge-Weber syndrome is a neurocutaneous disorder with angiomas involving the leptomeninges and the skin of the face (port wine stain). The syndrome can affect one or both cerebral hemispheres.



**Fig. 32.106:** Sturge-Weber syndrome. Axial unenhanced CT scan of brain shows marked subcortical and cortical calcification in both cerebral hemispheres in a gyriform pattern. The calcification is more extensive in the left cerebral hemisphere. There is evidence of cerebral atrophy with enlargement of the surrounding CSF spaces and thickening of the skull vault anteriorly (black arrow)



**Fig. 32.107:** Sturge-Weber syndrome. Post-contrast axial T1 weighted MR image shows pial enhancement which follows the gyral and sulcal contours of the entire left cerebral hemisphere (arrowheads). The choroid plexus in the left lateral ventricle is enlarged (arrow)—another feature of the syndrome

Contrast-enhanced MRI is the best imaging study for showing the extent of the pial angioma. After IV contrast administration, the angioma is identified as an area of enhancement following the contours of the gyri and sulci. Cortical calcification and cerebral atrophy is seen in long-standing cases. The cortical calcification is best demonstrated on CT scanning.

### Tuberous Sclerosis

Tuberous sclerosis is a genetic disorder which results in hamartoma formation in many organs, including the brain. Intracranial manifestations include:

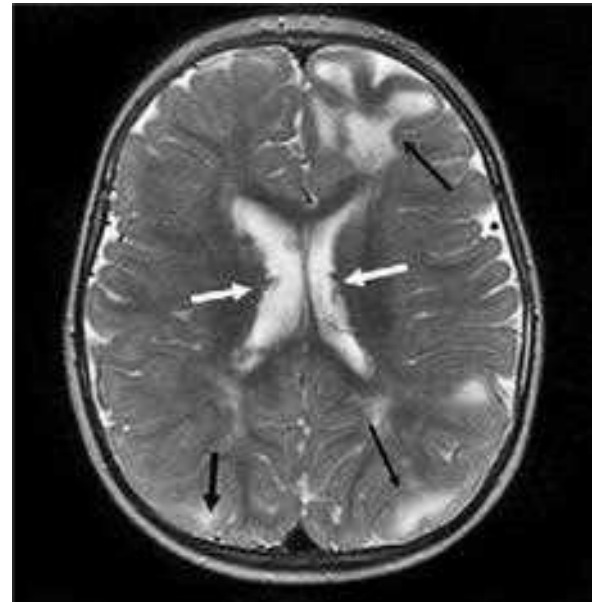


**Fig. 32.108:** Tuberous sclerosis. Axial unenhanced CT scan of brain shows calcified subependymal nodules within both lateral ventricles (arrows)

- Subependymal hamartomas—small nodules, which protrude into the ventricles (usually the lateral ventricles). These can be calcified.
- Cerebral hamartomas or cortical ‘tubers’—these hamartomas are identified as subcortical areas of abnormal signal intensity associated with adjacent gyral broadening. Cerebral hamartomas can also calcify.

### Vein of Galen Malformation

The malformation occurs because of a congenital connection between intracranial arteries and the vein of Galen or other primitive midline vein. On ultrasound, the malformation is

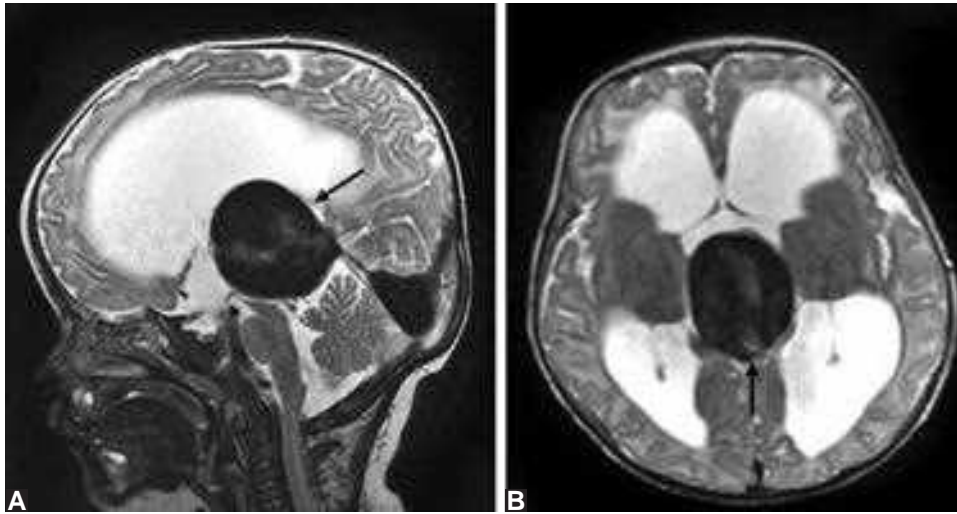


**Fig. 32.109:** Tuberous sclerosis. Axial T2-weighted MR image shows several subependymal nodules within both lateral ventricles (white arrows). The high signal intensity lesions within the cerebral hemispheres represent cortical tubers (black arrows)

usually identified as a round hypoechoic structure posterior to the third ventricle. Colour doppler studies can show the rapid blood flow within the malformation. On T2-weighted MR sequences, the malformation is identified as a low signal (black) structure posterior to the third ventricle. Intracranial complications include hydrocephalus and brain ischaemia.



**Fig. 32.110:** Vein of Galen malformation on ultrasound. Midline sagittal image shows blood flow within the malformation which lies posterior to the third ventricle (arrow)



**Figs 32.111A and B:** Vein of Galen malformation. T2-weighted MR sagittal (A) and axial; (B) Images demonstrating the malformation (black arrows). There is obstructive hydrocephalus involving the lateral and third ventricles

## TRAUMA, HYPOXIAISCHAEMIA AND HAEMORRHAGE

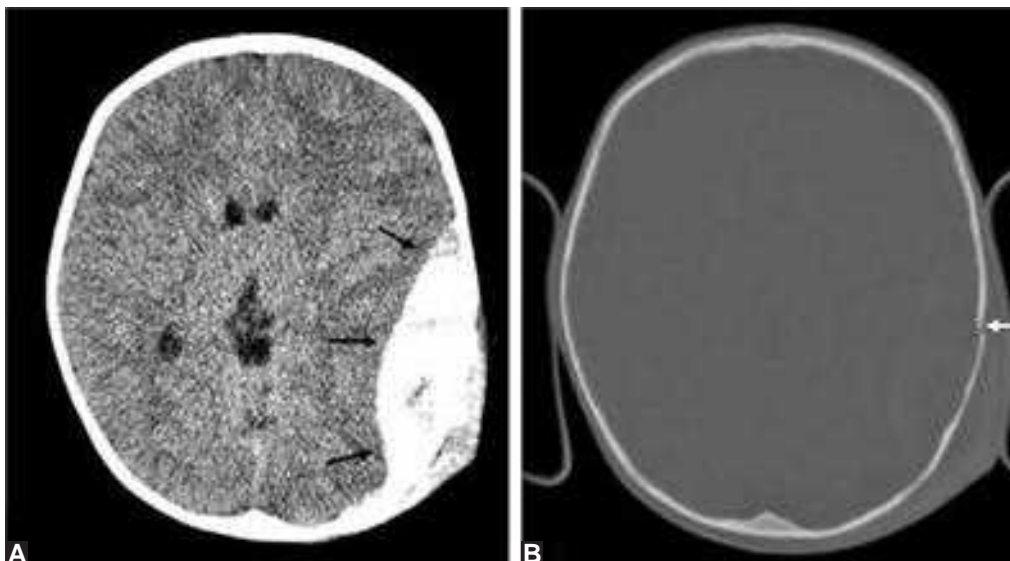
### Head Injury

As a general rule, CT is the initial study of choice for children who have sustained a head injury. Skull fractures, intracranial haemorrhage and any associated mass effect can be detected with CT.

On CT, an extradural haematoma is a biconvex collection of blood between the brain surface and the skull. The acute haematoma is of increased attenuation (i.e. appears white). A subdural haematoma is identified as a crescentic collection of blood between the brain surface and the skull.

### Periventricular and Intraventricular Haemorrhage in Premature Infants

Intracranial haemorrhage in the preterm infant has been divided into four grades:



**Figs 32.112A and B:** Left parietal skull fracture and extradural haematoma. (A) Unenhanced CT brain scan shows a large biconvex collection of blood adjacent to the left cerebral hemisphere (arrows); (B) The left parietal skull fracture is demonstrated (arrow)



**Fig. 32.113:** Acute left subdural haematoma. Unenhanced CT scan of brain demonstrates a crescentic collection of blood overlying the left cerebral hemisphere (arrow)



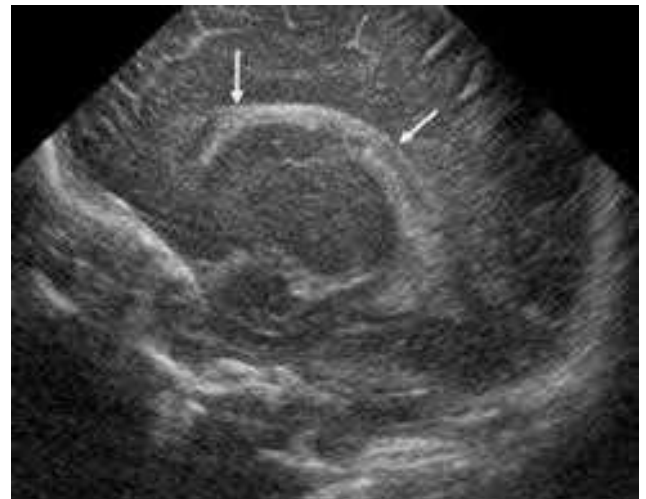
**Fig 32.114:** Normal parasagittal view of lateral ventricle (left). The head of the caudate nucleus (C) lies inferior to the body of the ventricle anteriorly. The thalamus (T) is located inferior to the body of the ventricle posteriorly. The echogenic choroid plexus (arrowheads) is seen within the ventricle. The caudothalamic groove is a small echogenic area, which lies between the head of caudate and the thalamus (arrow)

- Grade 1—subependymal haemorrhage only
- Grade 2—extension of subependymal haemorrhage into non-dilated ventricle
- Grade 3—intraventricular haemorrhage associated with ventricular dilatation
- Grade 4—periventricular parenchymal haemorrhage associated with intraventricular haemorrhage.

On cranial ultrasound, intraventricular haemorrhage is identified as echogenic material within the ventricle.



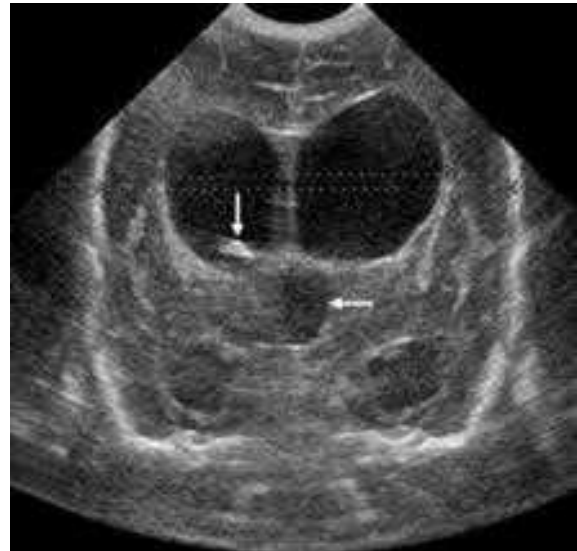
**Fig. 32.115:** Grade 1 haemorrhage. Left parasagittal ultrasound scan shows a focus of increased echogenicity in the caudothalamic groove in keeping with subependymal haemorrhage (arrow)



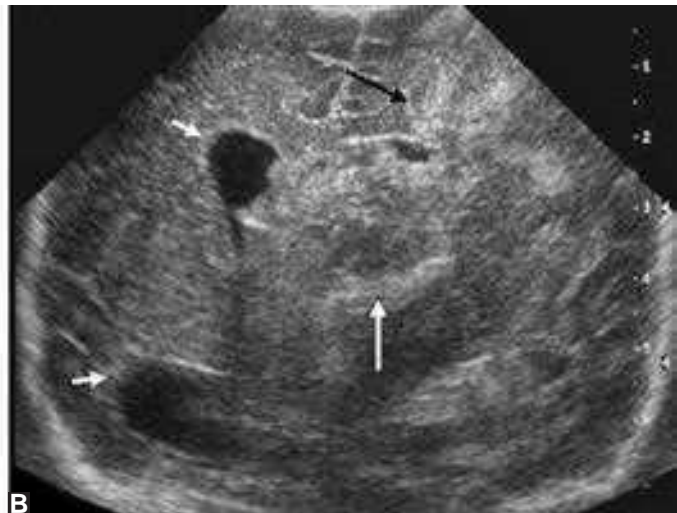
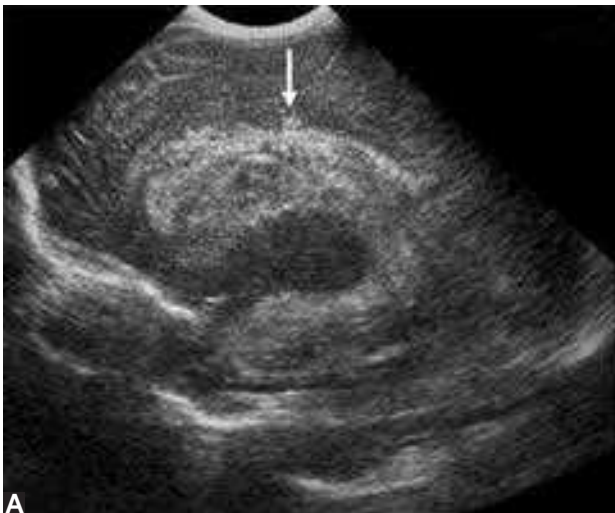
**Fig. 32.116:** Grade 2 intraventricular haemorrhage. Left parasagittal ultrasound scan shows blood within the left lateral ventricle (arrows). The ventricle is not dilated



**Fig. 32.117:** Grade 3 intraventricular haemorrhage. Right parasagittal ultrasound scan shows haemorrhage (arrows) in the right lateral ventricle which is dilated



**Fig. 32.119:** Post-haemorrhagic hydrocephalus. Coronal ultrasound scan shows marked dilatation of both lateral ventricles and the third ventricle (thick arrow). Some residual clot is present in the right lateral ventricle (thin arrow)



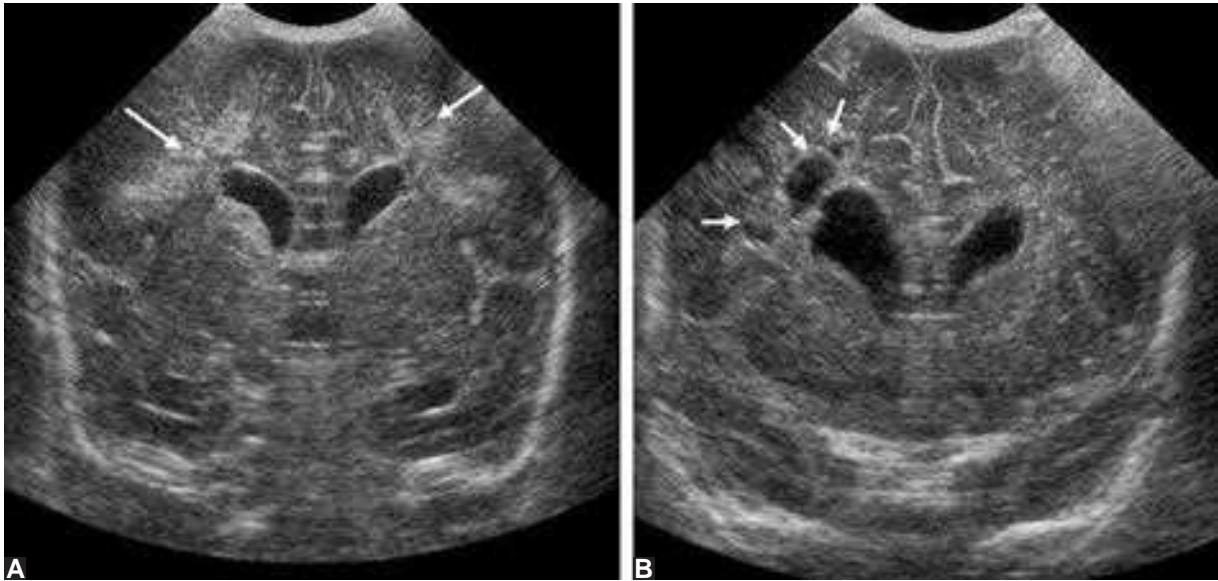
**Figs 32.118A and B:** Grade 4 haemorrhage. (A) Left parasagittal ultrasound scan shows haemorrhage in the parenchyma adjacent to the left lateral ventricle (arrow); (B) Coronal ultrasound scan shows extensive intraventricular haemorrhage (white arrow) and periventricular parenchymal haemorrhage (black arrow). Note the obstructive hydrocephalus of the right lateral ventricle (small arrows)

### Post-haemorrhagic Hydrocephalus

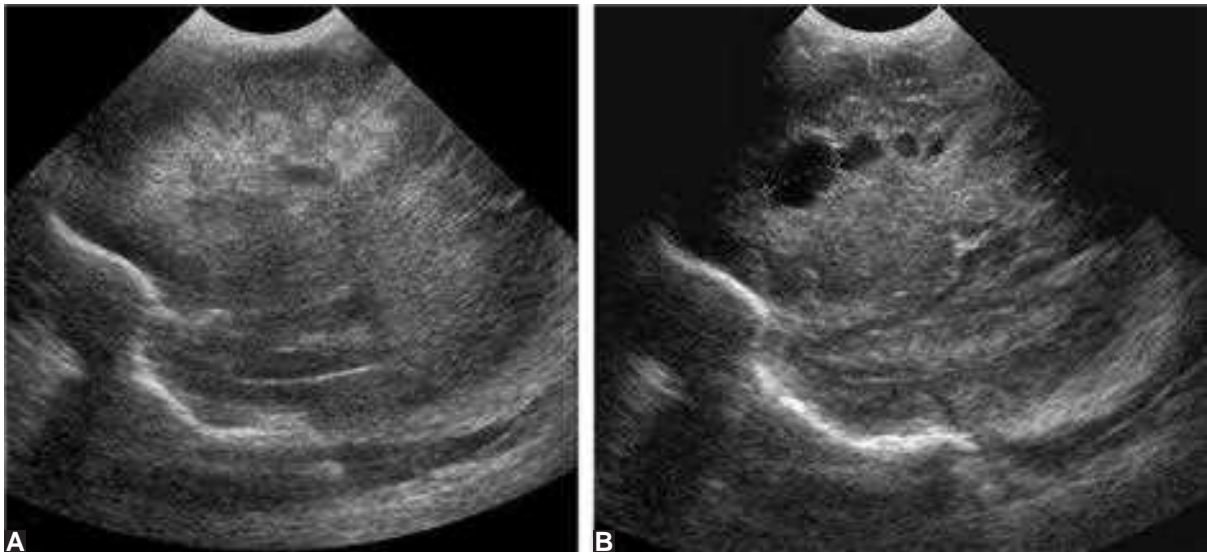
Ventricular dilatation after intraventricular haemorrhage occurs as a result of intraventricular obstruction by clot or septations or because of an obliterative arachnoiditis. The lateral ventricles usually dilate more than the third and fourth ventricles.

### Periventricular Leukomalacia

Periventricular leukomalacia (PVL) is an ischaemic brain injury in preterm infants affecting the deep white matter in the immediate periventricular region. The earliest sonographic sign is increased echogenicity in the periventricular white matter. Cystic change becomes evident within the injured periventricular white matter approximately 2–3 weeks following the ischaemic insult.



**Figs 32.120A and B:** Progression of PVL. (A) Coronal ultrasound scan at approximately one week of age shows increased periventricular echogenicity around the frontal horns of the lateral ventricles (arrows); (B) A follow-up ultrasound scan shows significant cavitation in the right frontal periventricular white matter (small arrows)



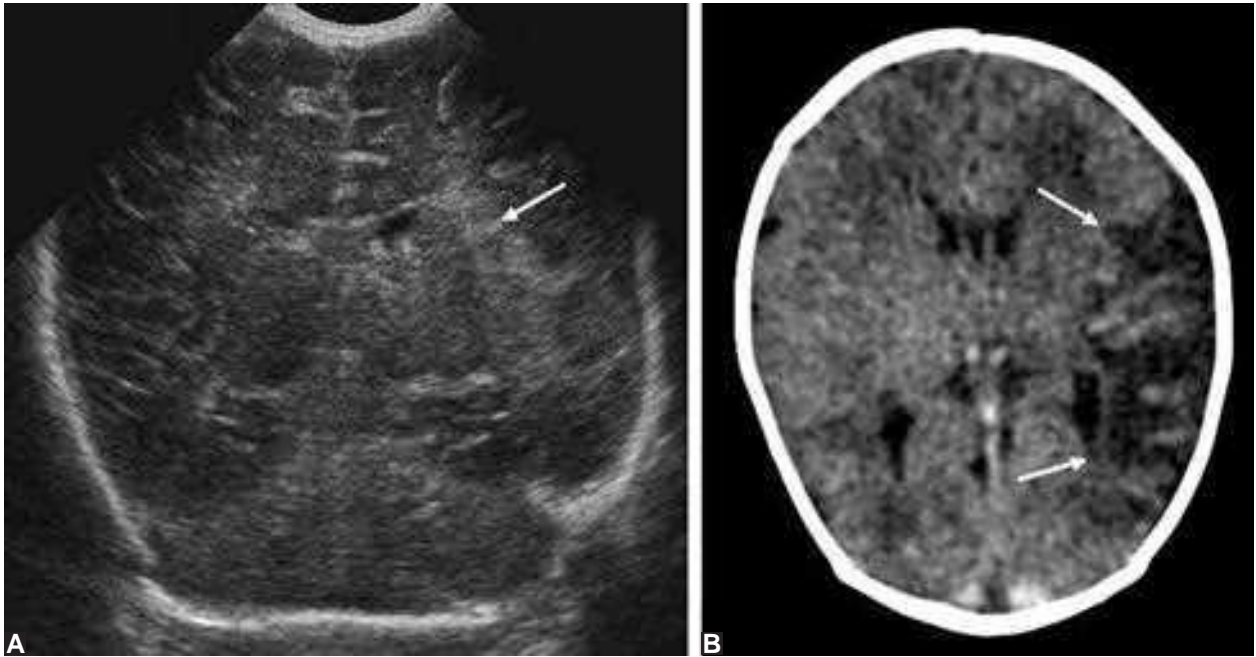
**Figs 32.121A and B:** PVL. (A) Parasagittal ultrasound scan shows increased echogenicity in the white matter adjacent to the right lateral ventricle; (B) Follow-up scan shows cavitation in the same area, consistent with cystic PVL

### Infarction

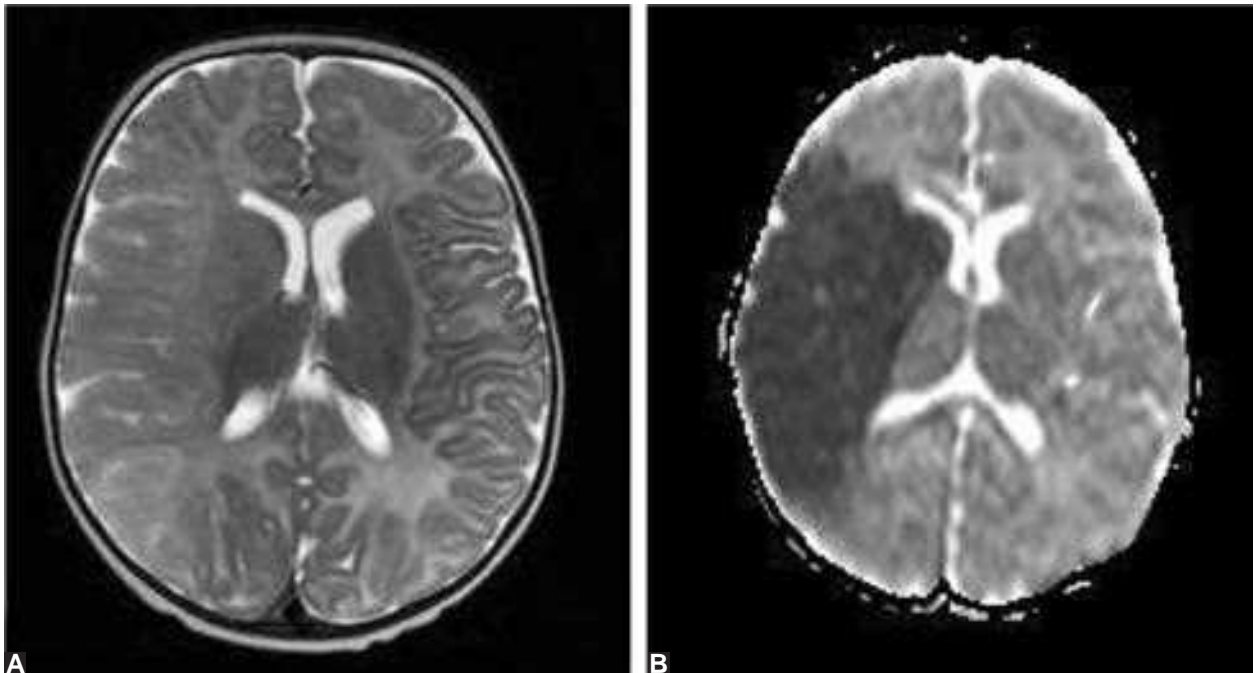
There are a number of causes of hypoxic-ischaemic brain infarction in infants and children. Cardiac causes, thrombotic conditions and metabolic diseases are a few categories of conditions responsible for strokes in the paediatric population.

Cranial ultrasound can be used to investigate neonates and infants in whom cerebral infarction is suspected. It is however less sensitive to CT and MR imaging in the detection of areas of hypoxicischaemic brain injury.

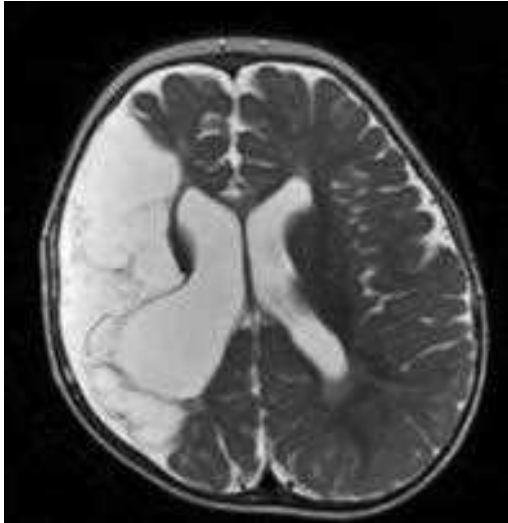




**Figs 32.122A and B:** Left middle cerebral artery (MCA) territory infarct. (A) Coronal ultrasound scan in a neonate shows subtle increased echogenicity in the left MCA territory (arrow); (B) Unenhanced axial CT scan shows decreased attenuation (dark area) in the left MCA territory, consistent with an infarct (arrows)



**Figs 32.123A and B:** Right middle cerebral artery (MCA) territory infarct. (A) Axial T2-weighted MR image shows subtle swelling and loss of grey-white matter differentiation in the right MCA territory, consistent with an acute infarct; (B) The ADC map of the diffusion sequence best demonstrates the acute infarct



**Fig. 32.124:** Established right middle cerebral artery (MCA) territory infarct. Axial T2-weighted MR image shows cystic change (encephalomalacia) in the right MCA territory, due to loss of brain tissue. The right lateral ventricle is enlarged due to the adjacent brain loss

## INFECTIONS, TUMOURS AND HYDROCEPHALUS

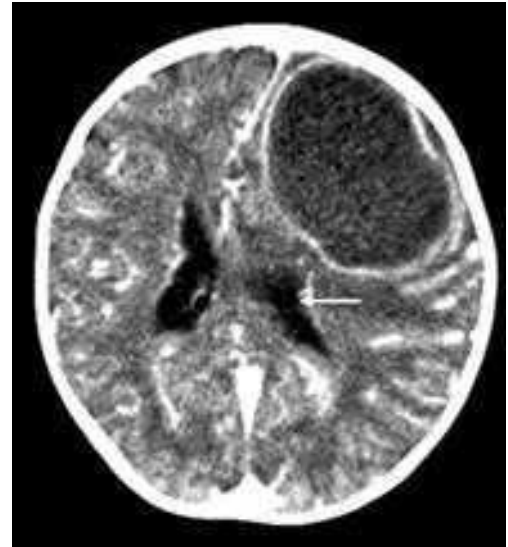
### Congenital Brain Infection

Congenital brain infection can be caused by cytomegalovirus, toxoplasmosis, herpes simplex virus, rubella, syphilis and human immunodeficiency virus. Radiological findings generally depend on the timing of the injury and the degree of brain destruction. Brain patterns identified include abnormal

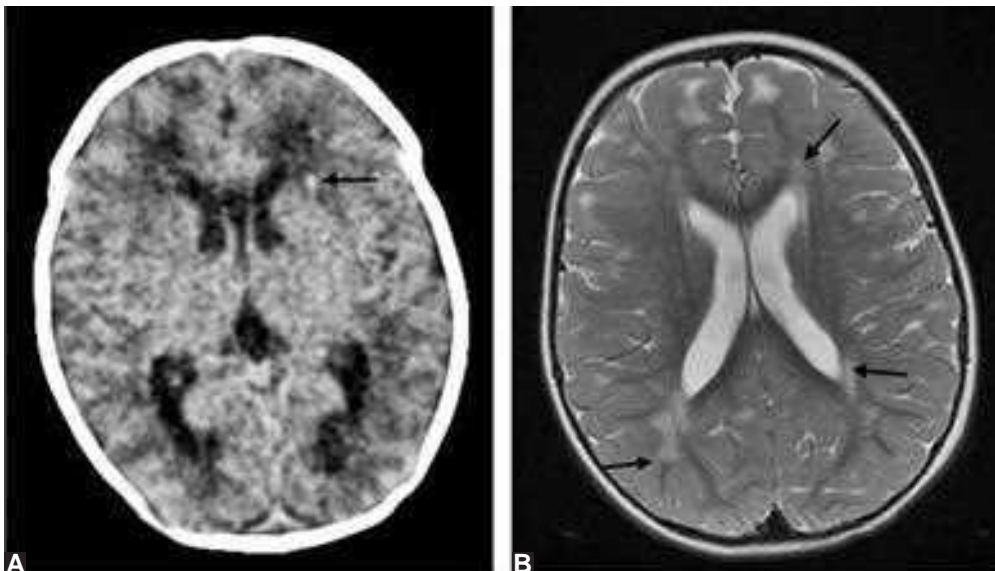
brain formation, periventricular white matter injury and intracranial calcification.

### Brain Abscess

Pyogenic organisms causing brain infection can reach the brain by haematogenous spread from a distant infection, extension of infection from adjacent sites (sinus or middle



**Fig. 32.126:** Left frontal lobe cerebral abscess in a child with congenital heart disease. Contrast-enhanced axial CT scan of brain shows a large low density lesion in the left frontal lobe, with an enhancing rim. Note the distortion of the anterior midline brain structures (arrowheads) and the left lateral ventricle (thin arrow)



**Figs 32.125A and B:** Congenital CMV infection of the brain. (A) Unenhanced axial CT scan of brain shows a tiny area of periventricular calcification (arrow) near the frontal horn of the left lateral ventricle; (B) Axial T2-weighted MR image shows abnormal areas of increased signal in the periventricular and deep white matter (arrows)

ear infection), as a result of congenital heart disease, or as a complication of a penetrating wound or sinus tract. Cerebritis is the earliest stage of purulent brain infection. If undetected or untreated, it can develop into an abscess.

### Tuberculous Meningitis

Central nervous system (CNS) manifestations of tuberculous (TB) infection include meningitis, tuberculoma, tuberculous abscess or spinal leptomeningitis.

In TB meningitis, a thick exudate fills the basal cisterns. The basal cisterns on contrast-enhanced scans shows the thick exudate blocks the subarachnoid space, causing hydrocephalus. Another complication is small vessel disease which results in basal ganglia and thalamic infarcts.

Tuberculomas are ring-enhancing lesions within the brain. They can be single or multiple.

### Hydrocephalus

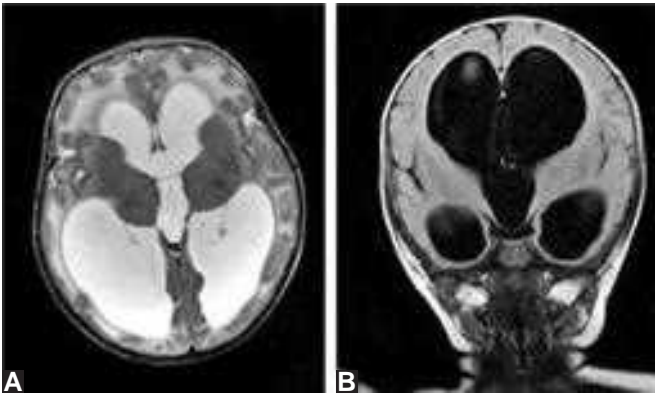
Hydrocephalus is a disorder where there is disturbance in the production, flow or absorption of cerebrospinal fluid (CSF). Consequently, there is increased CSF volume within the CNS, causing distension of the CSF pathways and increased pressure transmitted to the brain parenchyma.



**Fig. 32.128:** Hydrocephalus. Axial CT scan shows marked dilatation of both lateral ventricles



**Figs 32.127A and B:** Left frontal lobe tuberculoma. (A) Contrast enhanced axial CT scan shows a ring-enhancing lesion in the left frontal lobe of the brain. There is adjacent white matter oedema (arrow); (B) Axial T2 weighted MR brain image. The tuberculoma (black arrow) is isointense to brain. Note the adjacent white matter oedema (white arrow)



**Figs 32.129A and B:** Examples of hydrocephalus on MR imaging. (A) Axial T2-weighted MR scan demonstrates marked dilatation of both lateral ventricles and the third ventricle (arrow); (B) Coronal MR image from another patient also shows hydrocephalus involving both lateral ventricles and the third ventricle

### Tumours

Computed tomography (CT) is usually the imaging modality employed in the initial diagnosis of intracranial tumours. However, MR is becoming the preferred study because of its multiplanar imaging capability, which is useful for surgical planning. Furthermore, it can image the spine. This is a prerequisite for the staging of intracranial neoplasms which metastasise to the spine.

### Craniopharyngioma

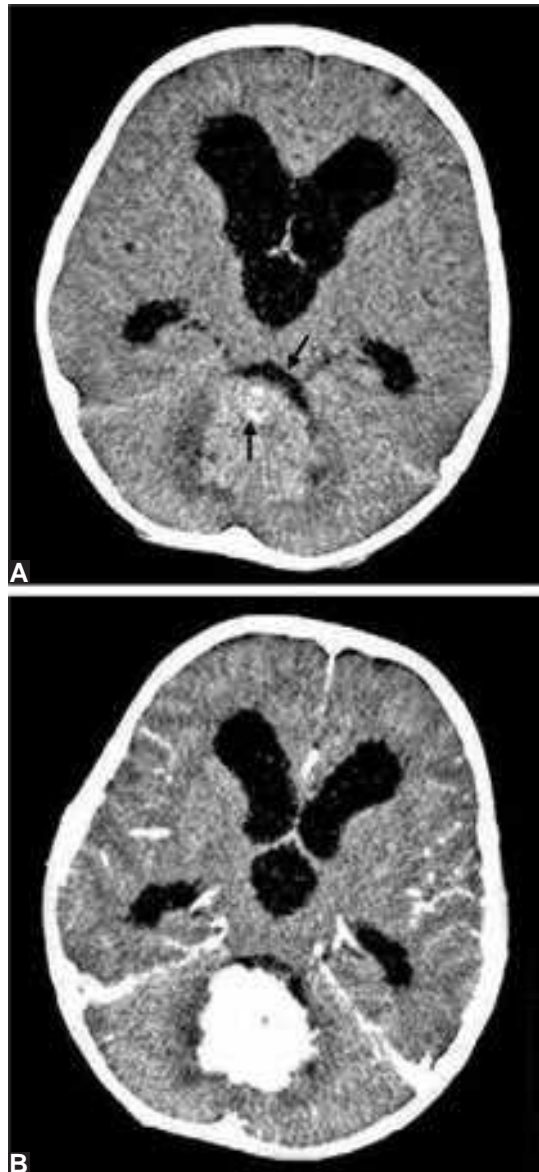
On CT scanning, craniopharyngiomas are identified as mass lesions in the suprasellar region, composed of cystic areas and calcification.



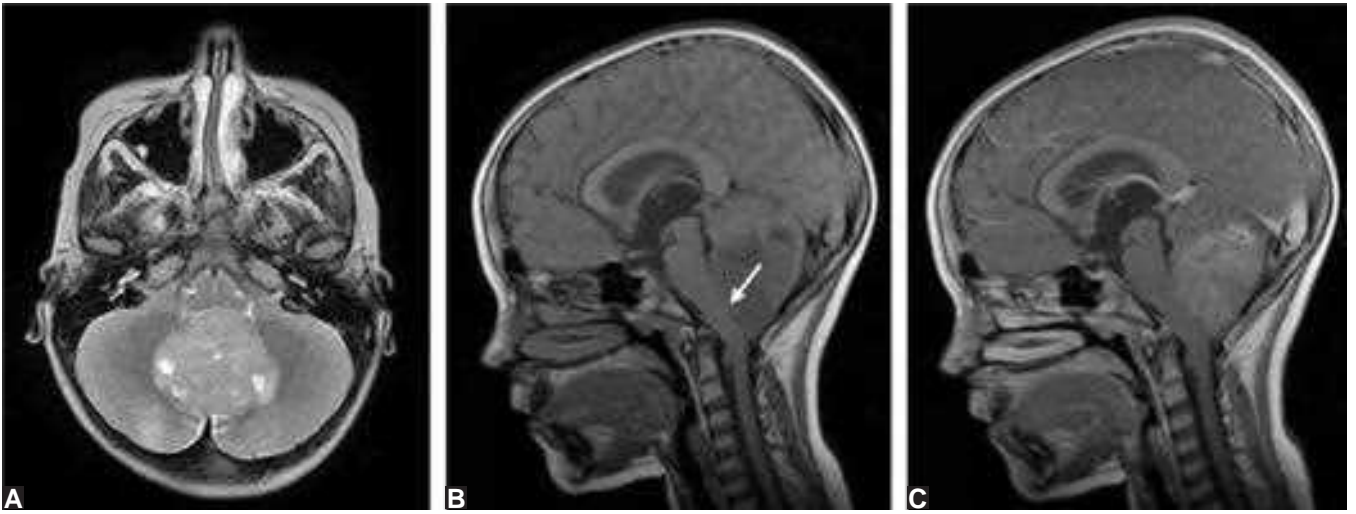
**Fig. 32.130:** Craniopharyngioma. Unenhanced axial CT brain scan shows a cystic (white arrow) and calcified (black arrow) lesion in the suprasellar region. Note the hydrocephalus affecting the lateral ventricles with marked dilatation of the temporal horns (small arrows)

### Medulloblastoma

A medulloblastoma on CT scanning is usually a dense neoplasm arising from the cerebellar vermis. Cystic change can be seen in approximately 50% of tumours and calcification in up to 20%. The tumours enhance with intravenous contrast. Hydrocephalus is usually present at the time of diagnosis.



**Figs 32.131A and B:** Medulloblastoma (A) Unenhanced axial CT scan shows a mass lesion situated within the cerebellar vermis, containing a small area of calcification (black arrow). The tumour is impinging upon the fourth ventricle, restricting CSF flow and consequently there is hydrocephalus of the lateral and third ventricles; (B) After injection of intravenous contrast, there is marked tumour enhancement



**Figs 32.132A to C:** Medulloblastoma. (A) Axial T2-weighted MR image shows a midline posterior fossa mass which is of increased signal intensity relative to the cerebellum; (B) Sagittal T1-weighted MR image shows the mass to be hypointense on this sequence. The mass is obstructing the fourth ventricle (arrow) and; (C) Sagittal T1-weighted MR image following intravenous contrast. The tumour demonstrates enhancement with contrast



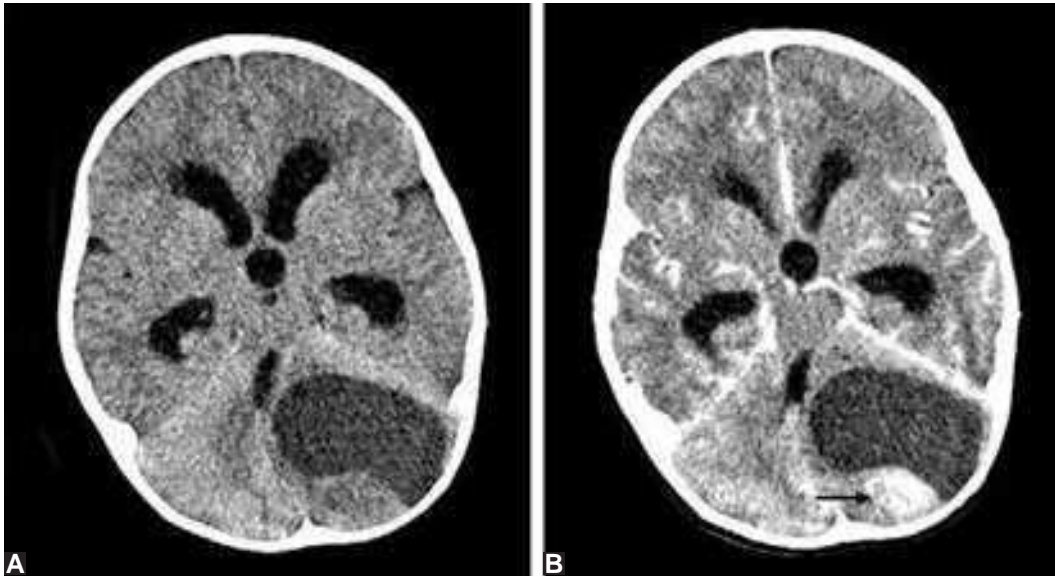
**Fig. 32.133:** Medulloblastoma spinal metastatic disease. Post-contrast T1-weighted sagittal MR scans of the whole spine show nodular tumour enhancement along the entire cord (arrows) consistent with spinal metastatic disease

### Cerebellar Astrocytoma

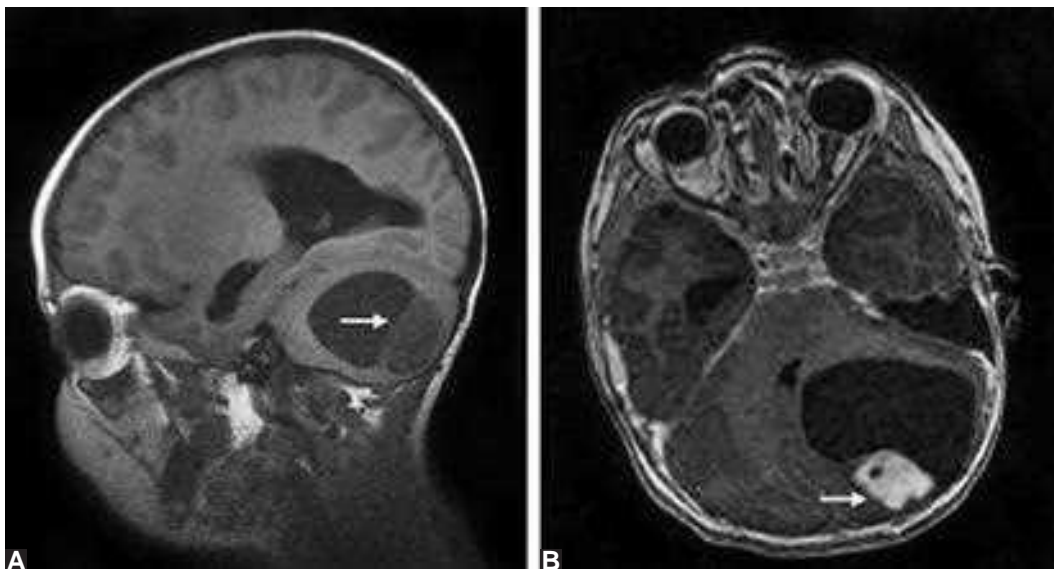
The cerebellar astrocytoma arises from the vermis or the cerebellar hemisphere. Most tumours are cystic with a tumour nodule located in the cyst wall. The mural nodule enhances with contrast. Hydrocephalus is usually present due to compression of the fourth ventricle.

### Ependymoma

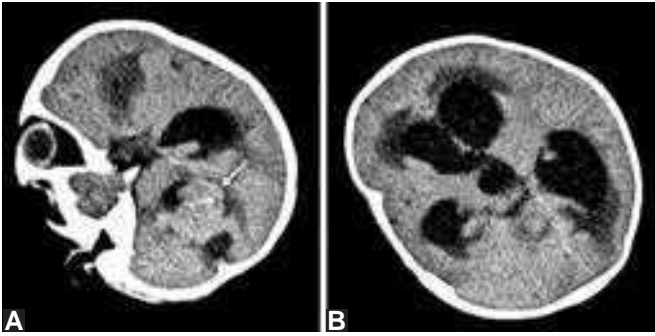
Ependymomas arise from the fourth ventricle and frequently grow out of the ventricle into the surrounding cisterns and foramina. Most ependymomas are solid in nature. Calcification is seen in up to 50% of tumours and cystic change in about 20%. Hydrocephalus is usually present at diagnosis.



**Figs 32.134A and B:** Pilocytic astrocytoma. (A) Unenhanced axial CT scan shows a cystic mass centred on the left cerebellar hemisphere. It distorts the fourth ventricle and there is hydrocephalus of the third and lateral ventricles; (B) Following intravenous contrast infusion, there is marked enhancement of a mural nodule in the posterior aspect of the cystic tumour (arrow)



**Figs 32.135A and B:** Pilocytic astrocytoma. (A) Sagittal T1-weighted MR image shows a hypointense cystic tumour in the cerebellum. The mural nodule is situated posteriorly within the tumour (arrow); (B) Axial T1-weighted MR image shows intense enhancement of the tumour nodule following intravenous contrast administration (arrow)



**Figs 32.136A and B:** Ependymoma. (A) Unenhanced axial CT scan through the posterior cranial fossa shows an isodense mass (arrow) containing punctuate calcification, arising from the fourth ventricle; (B) Axial image from a higher level shows hydrocephalus affecting the lateral ventricles and the third ventricle

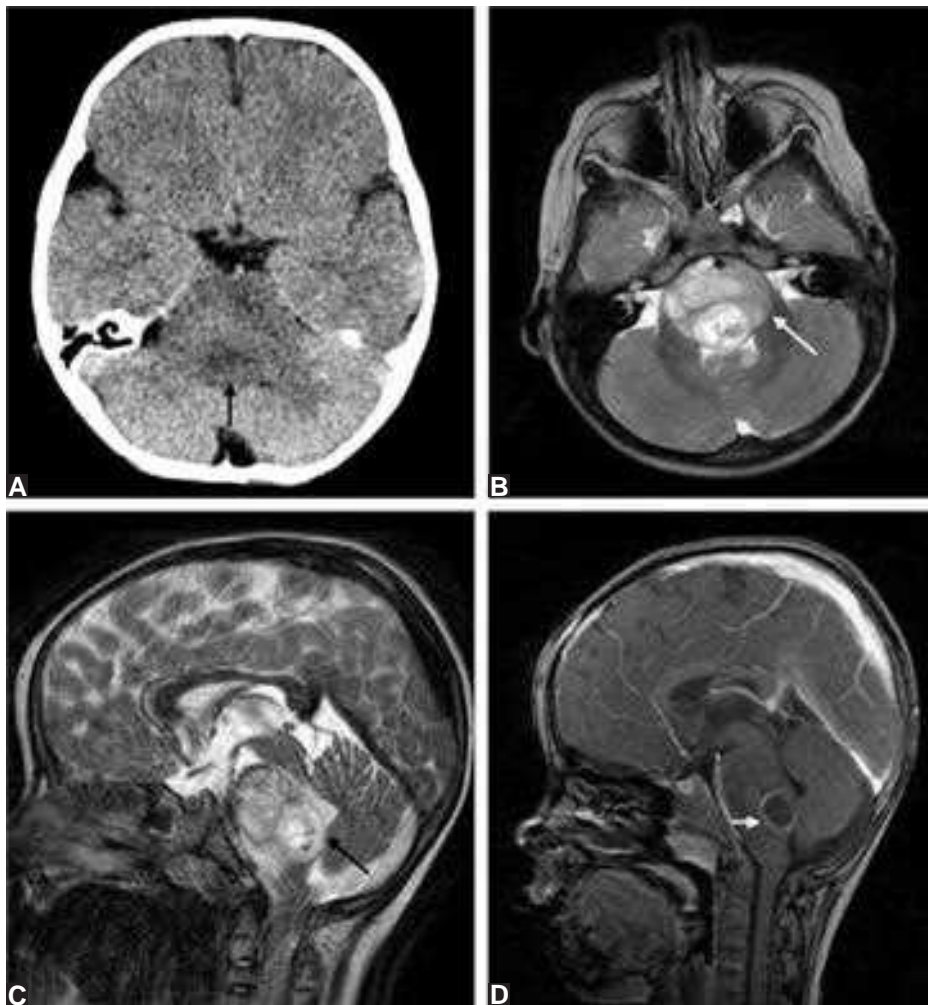
### Brain Stem Glioma

Because of its location, MR is the best imaging modality for assessing the brain stem glioma. It allows multiplanar assessment of the tumour. In contrast to CT scanning, there is no bony artefact from the adjacent skull base.

Most brain stem gliomas arise from the pons. The tumour may be focal or diffuse and typically expands the pons. Tumour enhancement with intravenous contrast agents is variable.

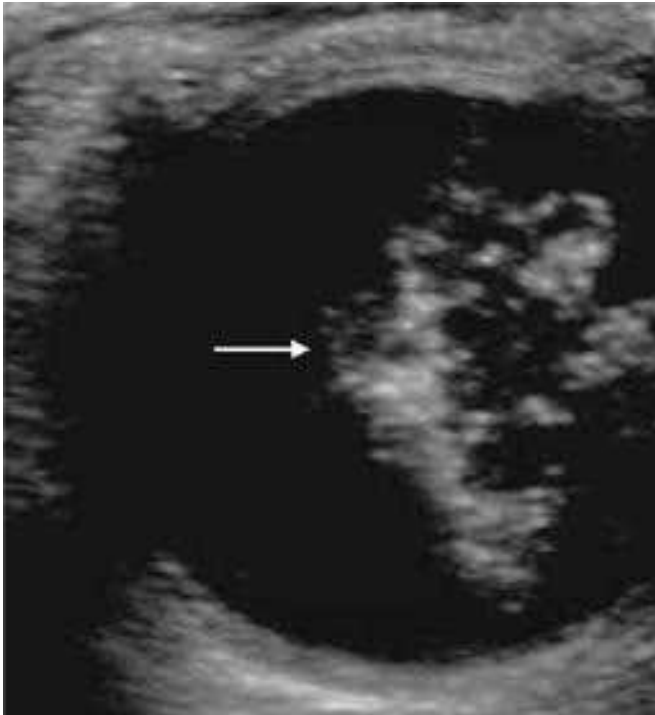
### Retinoblastoma

Retinoblastoma is the commonest orbital malignancy and is almost universally a tumour of infancy. The tumour can be unilateral or bilateral. Calcification is present in excess of 90% of tumours.

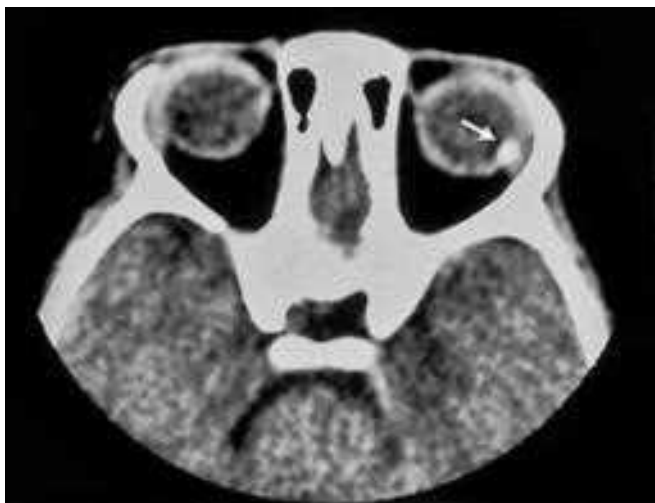


**Figs 32.137A to D:** Brain stem glioma. (A) Axial unenhanced CT scan shows a poorly defined low density mass in the pons (arrow); (B) Axial and; (C) Sagittal T2-weighted MR images show a heterogeneous mass of increased signal intensity expanding the pons (arrows). There is minor distortion of the fourth ventricle; (D) T1-weighted sagittal MR scan following intravenous contrast administration. There is peripheral enhancement of a cystic area posteriorly within the tumour (arrow). The remainder of pontine glioma is poorly enhancing

On CT scanning, the retinoblastoma is identified as a calcified mass within the globe, arising from the retina. It usually enhances with intravenous contrast.



**Fig. 32.138:** Retinoblastoma. Ultrasound scan of right globe reveals an irregular mass (arrow) containing multiple specks of calcification



**Fig. 32.139:** Retinoblastoma left orbit. Unenhanced axial CT scan through the orbits shows a small calcified lesion arising from the retina in the temporal aspect of the left globe (arrow)



**Fig. 32.140:** Left-sided retinoblastoma, axial T1-weighted MR image (fat saturated and post-contrast administration) shows an enhancing mass lesion situated posteriorly within the left globe (arrow)

## CONGENITAL SPINE LESIONS

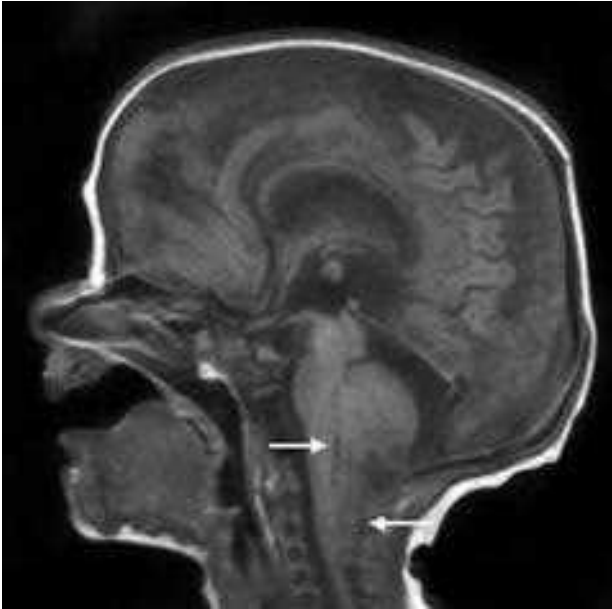
### Myelomeningocele

Myelomeningocele results from impaired closure of the caudal end of the neural tube. This results in an open lesion or sac containing abnormal spinal cord, nerve roots and meninges which herniate through a posterior defect in the vertebral column.



**Figs 32.141A and B:** Myelomeningocele and hydrocephalus. (A) Sagittal T1-weighted MR image of the lower spine shows a large lumbosacral meningocele. The spinal cord is stretched and can be identified passing through the posterior spinal defect (arrow); (B) Axial T2-weighted MR image of the brain shows marked dilatation of the lateral ventricles due to hydrocephalus





**Fig. 32.142:** Chiari II malformation. Sagittal T1-weighted MR image shows a small posterior cranial fossa and inferior displacement of the cerebellum through the foramen magnum (white arrow). The fourth ventricle is narrow and displaced caudally (white arrow)

Closure of the spinal defect is usually performed within 48 hours of delivery and consequently imaging studies of the spine are rarely performed preoperatively.

Myelomeningocele is associated with the Chiari II malformation. The malformation is associated with caudal displacement of the medulla, fourth ventricle and cerebellum into the cervical spinal canal. Consequently there is elongation of the pons and fourth ventricle. In combination, these features impede the flow and absorption of CSF causing hydrocephalus, usually after surgical closure of the spinal defect.

### Diastematomyelia

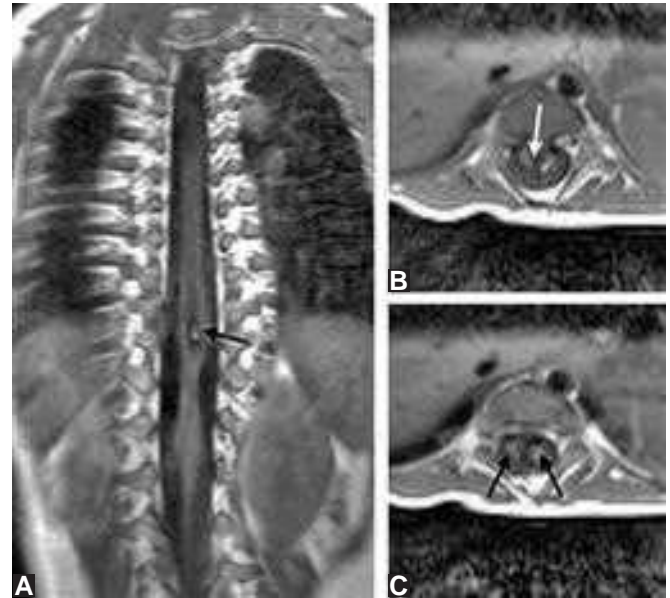
Diastematomyelia is the sagittal division of the spinal cord into two hemicords by a bony or cartilaginous spur, or fibrous septum. MRI is the preferred modality for imaging children with suspected diastematomyelia. The defect is most commonly found in the lumbar region.

### Sacroccygeal Teratoma

This is a rare congenital tumour that develops in the sacroccygeal region. The tumour usually presents as an external mass protruding from the gluteal cleft or the perineum. The tumour is divided into 4 types:

Type I: Tumours are predominantly external, situated posteriorly, and have only a minimal presacral component.

Type II: Tumours have significant pelvic extension but the external portion predominates.



**Figs 32.143A to C:** Diastematomyelia. (A) Coronal and; (B) Axial T1-weighted MR images show a bony spur (arrow) extending posteriorly from a vertebral body in the lower thoracic spine, splitting the spinal cord into two hemicords; (C) Axial T1-weighted MR image obtained above the level of the bony spur shows the hemicords (arrows)

Type III: Tumours have a predominant internal component although the external component is still visible.

Type IV: Tumours are entirely presacral without any external component.



**Fig. 32.144:** Sacroccygeal teratoma in a neonate. Lateral radiograph shows a large exophytic soft tissue mass arising from the gluteal region. The lower density area within the lesion represents fat



**Fig. 32.145:** Sacrococcygeal teratoma. Sagittal T2-weighted MR image demonstrates a large cystic structure in the presacral region. Some solid elements are present inferiorly within the lesion (arrow). There is significant anterior displacement of the rectum and bladder by the mass. This is a type III tumour since it has a small external component

Plain films will demonstrate a large soft tissue mass associated with the lower sacrum and coccyx. Approximately two-thirds of tumours will contain calcification.

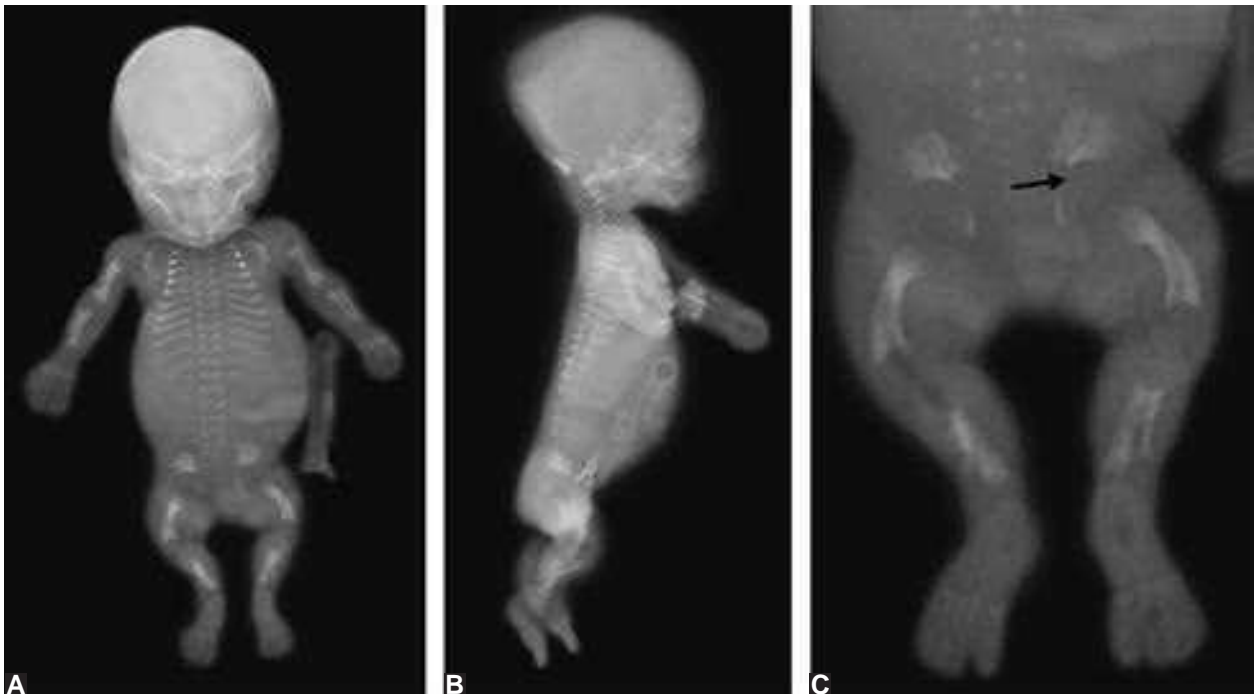
## PAEDIATRIC SKELETAL RADIOLOGY

### SKELETAL DYSPLASIAS

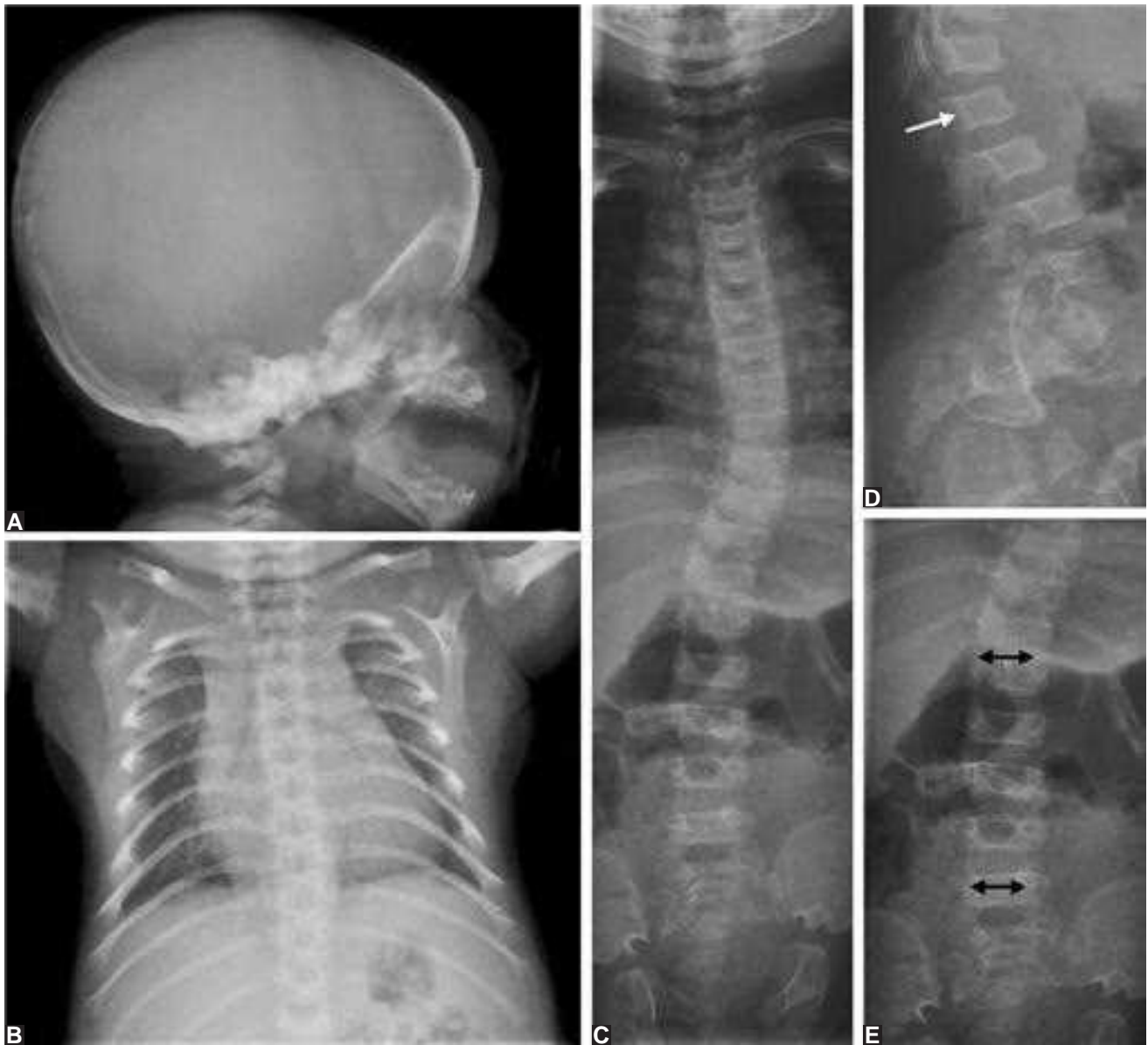
#### Thanatophoric Dysplasia

##### Radiographic Findings

- Skull: Proportionately large skull relative to trunk
- Thorax: Long narrow trunk with very short ribs, small abnormal scapulae
- Spine: Small, flat vertebrae with U or H shaped vertebrae in the AP projection
- Pelvis: Small flared iliac wings, narrow sacrosciatic notches and flat acetabula
- Limbs: Long bone shortening and bowing; French telephone receiver femurs
- Hands and feet: Marked shortening and broadening of the tubular bones.



**Figs 32.146A to C:** Thanatophoric dysplasia. (A) The head is proportionately large and the trunk is long and narrow. There is marked rib shortening and the scapulae are small. There is shortening of the long bones of the limbs (micromelia)-note the French telephone receiver femurs. The vertebral bodies are flat and H-shaped; (B) The lateral view shows the flattened vertebrae and the proportionately large skull and; (C) Coned view of the pelvis and lower limbs demonstrates small, flared iliac wings, narrowed sacrosciatic notches (black arrow) and horizontal acetabula



**Figs 32.147A to E:** Achondroplasia in newborn infant. (A) Large skull with midface hypoplasia; (B) Small thorax with short ribs; (C) AP and lateral views of spine show a thoracolumbar kyphoscoliosis. (D) The lateral view shows posterior vertebral body scalloping (arrow) and a horizontal sacrum and; (E) AP view of lumbar spine demonstrates gradual reduction in interpediculate distance caudally (arrows)

## Achondroplasia

### Radiographic Findings

- Skull: Large skull with relatively small base and midface hypoplasia
- Thorax: Small short ribs which are splayed anteriorly
- Spine: Short flat vertebral bodies. Short pedicles with decreasing interpedicular distance caudally in lumbar spine. Posterior scalloping of vertebral bodies
- Pelvis: Champagne glass appearance of pelvis. Flared iliac wings, narrow sacrosiatic notches and flat acetabular roofs
- Limbs: Short and thick tubular bones, flared metaphyses
- Hands: Shortening and broadening of metacarpal and phalangeal bones.



**Figs 32.148A to D:** Achondroplasia in neonate. (A) The pelvis X-ray shows flared iliac bones, flat acetabular roofs and narrow sacrospinous notches; (B) and; (C) Limb X-rays show shortening of the long bones; (D) Hand: Short and broad metacarpal and phalangeal bones

## MUCOPOLYSACCHARIDOSES

### Mucopolysaccharidosis 1-H (Hurler Syndrome)

#### Radiographic findings:

- Skull: Large skull with abnormal J-shaped sella
- Thorax: Short thick clavicles, broad 'oar-shaped' ribs and hypoplastic glenoid
- Spine: Antero-inferior beaking of thoracolumbar vertebral bodies, atlantoaxial subluxation due to hypoplastic dens
- Pelvis: Small, flared iliac wings; steep
- Limbs: Widening of the midshaft of long bones
- Hands: Widening of the diaphyses of the metacarpals and proximal and middle phalanges; phalangeal shortening; small and irregular carpal bones, pointed proximal ends of the metacarpals.



**Figs 32.149A to D:** Hurler's syndrome. (A) Lateral radiograph demonstrates an enlarged skull. The dens is hypoplastic (arrow); (B) Frontal chest X-ray shows thickened clavicles and broad ribs. The glenoid fossae are poorly formed (arrows); (C) The lateral spine film features a thoracolumbar gibbus, and anteroinferior beaking of the vertebrae at the apex of the gibbus (arrows) and; (D) The pelvic X-ray demonstrates small, flared iliac wings and steep acetabular roofs



**Fig. 32.150:** Hurler's syndrome: Hand radiograph. X-ray of right hand reveals widening of the diaphyses of the metacarpals and proximal and middle phalanges. The phalanges are short. The carpal bones are small and irregular. There is proximal tapering of the metacarpals. The distal radius and ulna tilt towards each other



**Fig. 32.151:** Morquio's syndrome. Lateral radiograph of lower thoracic spine demonstrates decreased height of the vertebral bodies (platyspondyly). Note the central anterior bony protrusion or beaking of the vertebral bodies (arrows)

### Mucopolysaccharidosis IV (Morquio Syndrome)

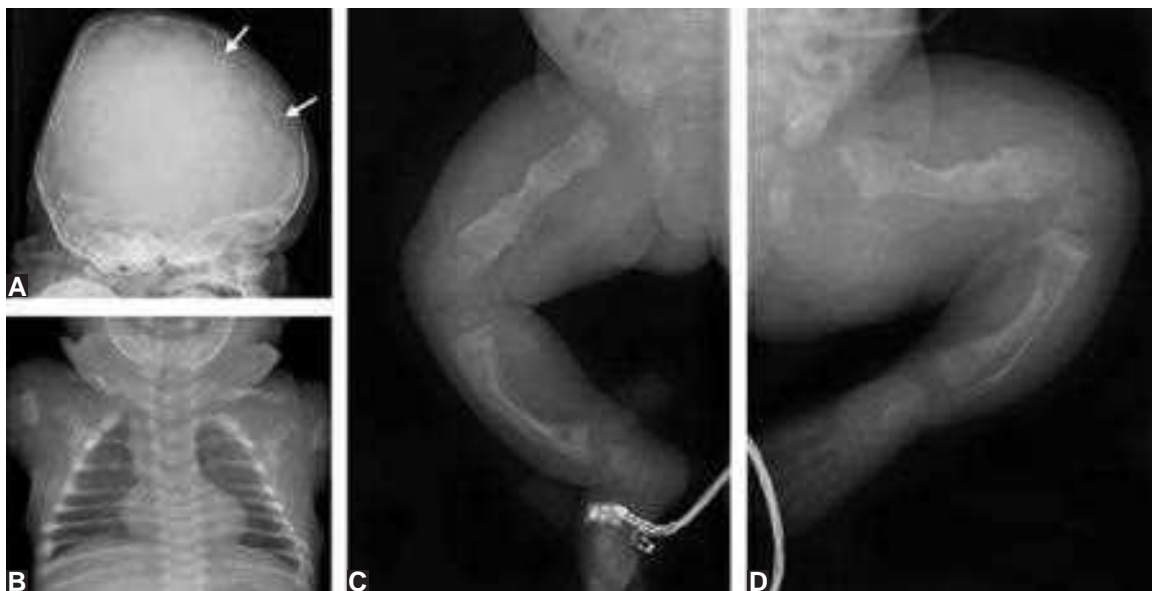
#### Radiographic Findings:

- Thorax: Flaring of ribs
- Spine: Platyspondyly within thoracolumbar spine; central anterior bony beaking; odontoid hypoplasia and atlanto-axial instability

- Pelvis: Steeply oblique acetabular roofs; defective irregular ossification of femoral heads leading to flattening
- Limbs: Widening of the long bone diaphyses; irregular metaphyses
- Hands: Small, irregular carpal bones; proximal tapering of metacarpals.

### Osteogenesis Imperfecta

There are a several types of osteogenesis imperfecta. The radiographic findings are variable and depend upon the type and severity of the disease.



**Figs 32.152A to D:** Osteogenesis imperfecta in a neonate. (A) Lateral skull film shows multiple intrasutural (Wormian) bones; (B) Chest radiograph demonstrates multiple healing rib fractures giving the ribs a beaded appearance. There is also a healing left clavicular fracture; (C) and; (D) There are multiple fractures within both lower limbs. The femurs are short and crumpled due to healing fractures and there is bowing deformity of the tibia and fibula bilaterally. The bones are osteopenic

**Radiographic Findings:**

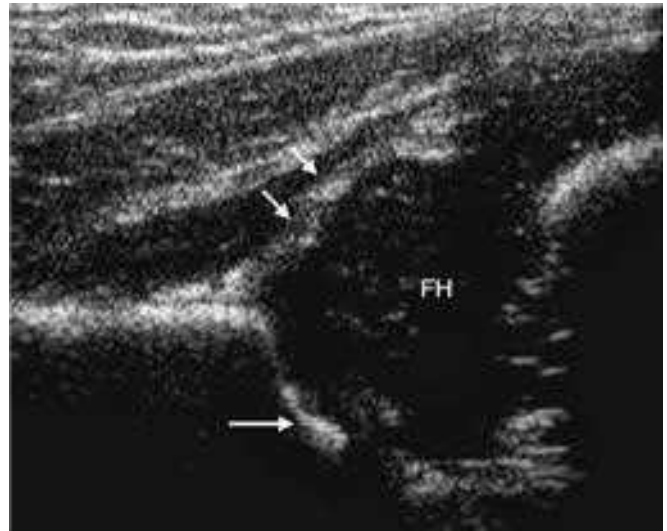
- Skull: Variable decreased ossification, abnormal number of wormian bones (small bones within the cranial sutures)
- Spine: Wedged or collapsed vertebrae, kyphoscoliosis
- Remainder of skeleton: Osteoporosis and fractures.

**PAEDIATRIC HIP ABNORMALITIES****Developmental Dysplasia of the Hip**

Developmental dysplasia of the hip (DDH) can be diagnosed radiologically using ultrasound or X-ray. Ultrasound is the preferred imaging modality in neonates since the neonatal hip is composed almost entirely of cartilage, thereby making it difficult to establish the relationship of the femoral head to the acetabulum on radiographs.

By 4 to 6 months of age, the femoral head ossifies and radiographs are then used to evaluate infants with suspected DDH. The radiographic findings in DDH are:

- Increased slope of bony acetabulum (acetabular dysplasia)
- Delayed growth of the femoral head ossification centre compared to the normal side
- A pseudoacetabulum, which is a late radiographic sign in DDH.



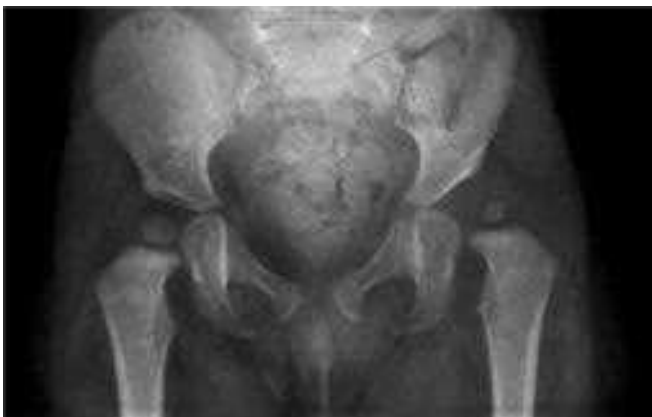
**Fig. 32.154:** Normal hip ultrasound. Coronal ultrasound scan of hip shows the femoral head (FH) covered by the bony acetabular roof (arrow) and acetabular labrum (arrowheads)



**Figs 32.153A to C:** Osteogenesis imperfecta in an older child. (A) The lateral spine X-ray shows wedging and collapse of several vertebral bodies. The child has a Portacath device in situ for intravenous biphosphonate treatment; (B) The right leg is in a plaster cast due to a recent midshaft spiral fracture of the right femur (arrow). There is also an older healing fracture in the proximal shaft; (C) There are fractures within the distal left tibia (arrows). Note the osteopenia. There is also lateral bowing of the distal tibia and fibula



**Fig. 32.155:** Decentred hip. Coronal ultrasound scan shows the cartilaginous femoral head (FH) lies out with the bony acetabular roof (arrow)



**Fig. 32.156:** Developmental dysplasia of hip and dislocation. There is increased slope of the left bony acetabulum. The left femoral head ossification centre is hypoplastic. The left femoral head is dislocated superiorly and laterally. The right hip is normal



**Fig. 32.157:** Late diagnosis of bilateral DDH in a four-year-old girl. Both hips are dislocated superiorly and laterally and articulate with pseudoacetabula (arrows)



### Legg-Calvé-Perthes Disease

Legg-Calvé-Perthes disease is avascular necrosis of the proximal (capital) femoral epiphysis. The peak incidence is 6-8 years of age. The disease can be bilateral.

The radiographic findings include flattening, sclerosis and fragmentation of the capital femoral epiphysis. Early subchondral fractures can be detected on frog lateral views as a curvilinear lucency within the epiphysis.

With progressive fragmentation and collapse of the femoral head, the femoral neck becomes short and wide. Eventually the epiphysis re-mineralises and heals. The healed capital femoral epiphysis is flat and wide.

### Slipped Capital Femoral Epiphysis

Slipped capital femoral epiphysis (SCFE) is a disease of the adolescent hip. The disease can be bilateral.

The radiographic findings of SCFE are:

- Widening of the epiphyseal plate
- Displacement of the femoral head posteriorly and medially.

Medial slippage can be identified on a frontal projection of the pelvis. Mild displacement, which may not be immediately apparent on the frontal projection, is best appreciated on the frog leg lateral view.



**Figs 32.158A and B:** Legg-Calvé-Perthes disease left hip. (A and B): Frontal and frog-leg lateral radiographs demonstrate flattening, irregularity, fragmentation and sclerosis of the left capital femoral epiphysis. The right capital femoral epiphysis is normal



**Figs 32.159A to D:** Serial radiographic changes of Legg-Calvé-Perthes disease of right hip. (A) Radiograph at presentation demonstrates flattening and sclerosis of the right capital femoral epiphysis; (B) Radiograph five months later reveals further loss of epiphyseal height; (C) Ten months later, there is marked fragmentation and flattening of the right capital femoral epiphysis; (D) Two and a half years after the onset, the capital femoral epiphysis has healed but is flatter and wider to fit the widened femoral neck



**Fig. 32.160:** Slipped right capital femoral epiphysis. Frontal radiograph of the pelvis demonstrates medial slippage of the right capital femoral epiphysis. A line drawn along the lateral femoral neck on the normal left side intersects a portion of the femoral epiphysis. However, a similar line drawn along the lateral aspect of the right femoral neck just misses the epiphysis



**Fig. 32.161:** Left slipped capital femoral epiphysis. Frog leg lateral view shows mild slippage of the left capital femoral epiphysis (arrow)

## METABOLIC BONE DISORDERS

### Rickets

There are a number of clinical conditions which can lead to the development of rickets. The radiographic features of this metabolic disorder are shared, whatever its underlying cause.

#### Radiographic Findings:

- Demineralisation
- Widening of the growth plate
- Cupping, fraying and splaying of the metaphysis, which is of reduced density
- Thin bony spur extending from the metaphysis to surround the uncalcified growth plate
- Indistinct cortex because of uncalcified subperiosteal osteoid
- Poorly ossified epiphyses with faint, indistinct borders.



**Fig. 32.162:** Rickets. Radiograph of the left wrist shows a wide distal radial growth plate. Note the cupping, fraying and splaying of the distal radial and ulnar metaphyses. There is a prominent bony spur extending from the distal radial metaphysis (arrow). The distal radial epiphysis is poorly ossified and has an indistinct contour. The forearm bones are demineralised with coarsened trabeculae and indistinct cortices

### Scurvy

Scurvy is the result of vitamin C deficiency.

#### Radiographic Findings:

- Generalised osteopenia
- Dense zone of provisional calcification due to excessive calcification of osteoid
- Metaphyseal lucency
- Metaphyseal corner fractures through the weakened lucent metaphyses (Pelkan spurs)
- Periosteal reaction due to subperiosteal haematoma
- Loss of epiphyseal density with a pencil thin cortex.



**Fig. 32.163:** Scurvy. AP radiograph of the knees. Transverse bands of metaphyseal lucency lie adjacent to dense zones of provisional calcification (white arrows). There are metaphyseal corner fractures through the weakened metaphyses (white arrows)

### Lead Poisoning

Lead intoxication may occur by ingesting or inhaling the metal. Lead is present in many products including leaded petrol, old water pipes and lead paint. Exposure to lead can lead to anaemia, abdominal symptoms (abdominal pain, vomiting, diarrhoea), a blue line around the gums and encephalopathy. In the skeletal system, lead intoxication causes widening of the cranial sutures (due to increased intracranial pressure) and dense transverse lines in the metaphyses of tubular bones. Opaque lead particles can be seen within bowel on abdominal radiographs.



**Fig. 32.164:** Lead poisoning. AP radiograph of the knees reveals transverse bands of increased density in the metaphyses of the long bones (arrows)

## INFLAMMATORY JOINT AND MUSCLE CONDITIONS

### Juvenile Idiopathic Arthritis

Plain radiography in the early stages of juvenile idiopathic arthritis (JIA) is usually unhelpful. Soft tissue swelling and periarticular osteopenia may be visible. Late findings include joint space loss (due to cartilage loss), bony erosions and joint subluxation or dislocation. In children, growth disturbance can occur with epiphyseal overgrowth and premature growth plate fusion.



**Fig. 32.165:** Juvenile idiopathic arthritis of both knees. The bones are osteopenic and there is significant joint space loss at the femorotibial joints. Subarticular bony erosions are present (arrow). The epiphyses are enlarged (overgrowth). There is slight lateral subluxation of the tibia in relation to the femur bilaterally



**Fig. 32.166:** Juvenile idiopathic arthritis of the left hand and wrist. There is osteopenia, especially in a periarticular distribution. There is significant joint space loss at the radiocarpal and carpal joints. Note the irregularity of the carpal bones. Joint space loss is also present at the metacarpophalangeal and the interphalangeal joints. There is soft tissue swelling of the fingers proximally

## Dermatomyositis

Juvenile dermatomyositis is the most common idiopathic inflammatory condition of muscle in children.

MRI is helpful in establishing the diagnosis of dermatomyositis and is also useful in assessing the response to treatment.

Soft tissue calcification is best demonstrated on plain films. Calcium deposition in soft tissues usually occurs around pressure-point sites: the buttocks, knees and elbows. Calcium deposition occurs in the cutaneous and subcutaneous tissues, muscles and fascial planes.



**Fig. 32.167:** Dermatomyositis. Coronal T2-weighted MR sequence through the thighs with fat saturation shows diffusely abnormal increased signal intensity within the muscles of both thighs and also within the subcutaneous tissues

## BONE INFECTIONS

### Congenital Syphilis

Congenital syphilis is caused by transplacental spread of *Treponema pallidum*.

The radiographic features in infants include:

- Metaphyseal lucent bands
- Metaphyseal serration (sawteeth)
- Metaphyseal bony destruction on the medial aspect of the proximal tibia
- Periosteal reaction
- Diaphyseal destructive lesions.



**Fig. 32.169:** Congenital syphilis. Radiograph of left forearm in a neonate shows metaphyseal lucency within the long bones, best demonstrated in the distal radius and ulna (arrows)



**Figs 32.168A to C:** Dermatomyositis. (A) AP radiograph of both knees shows amorphous calcification mainly in the cutaneous tissues bilaterally; (B and C) AP and lateral radiographs of right elbow. There is extensive calcification in the cutaneous tissues and in the muscles around the elbow joint



**Fig. 32.170:** Congenital syphilis. There are bilateral symmetric destructive metaphyseal lesions on the medial aspect of the tibiae. There is also significant periosteal reaction along the diaphyses of the femurs and tibiae (arrows)

The radiographic features of congenital syphilis in childhood are:

- Periosteal and cortical thickening
- Focal destructive lesions.

## Osteomyelitis

Osteomyelitis is an acute or chronic inflammatory condition of bone and its adjacent structures due to pyogenic organisms. Radiographs often show no bony abnormality in the early stages, although soft tissue swelling may be evident. Bony involvement is often not detected on radiographs until the second week of the disease. This is manifest as radiolucent areas, usually in the metaphysis, where bony destruction has occurred. Periosteal reaction is also evident. If treatment is delayed or ineffective, there is an increase in the amount of periosteal reaction to form an involucrum around the fragments of dead bone (sequestrum).

## HAEMOLYTIC ANAEMIAS

### Thalassaemia

#### *Skeletal Findings:*

- Skull: Osteoporosis; expansion of the diploic space, especially in the frontal bone; thinning of the outer table of the skull; hair-on-end appearance. Hypoplasia of the paranasal sinuses due to expansion of the facial bones; malocclusion of the jaw
- Trunk: Osteoporosis, coarse bony trabeculae and cortical thinning. Accentuation of vertical trabecular pattern in the vertebrae; biconcave vertebral bodies
- Tubular bones: Widened medullary cavity and cortical thinning.



**Figs 32.171A and B:** Osteomyelitis proximal right humerus. (A) AP radiograph at time of presentation shows patchy radiolucency within the proximal right humeral shaft and faint periosteal reaction (arrow); (B) Follow-up radiograph one month later with treatment. The lucent area within bone is smaller and well-defined. The periosteum has produced new cortical bone (arrows)



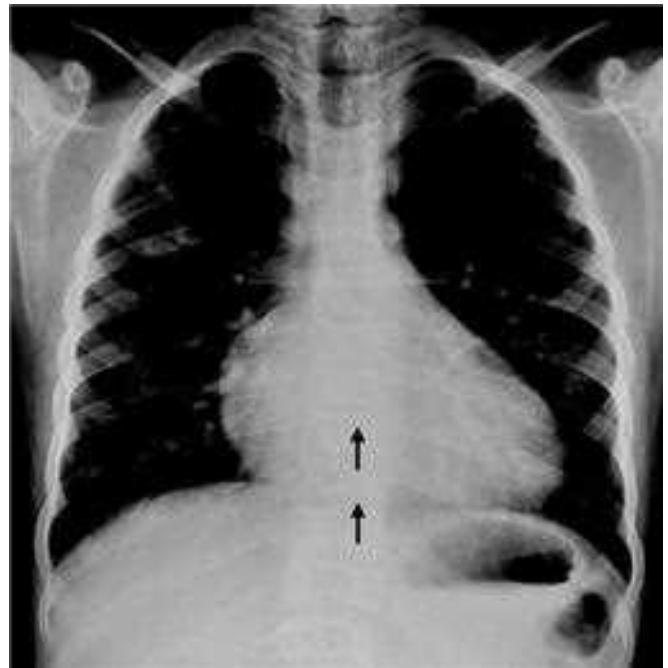
**Fig. 32.172:** Thalassaemia. There is widening of the diploic space and thinning of the outer table of the skull. Note the hair-on-end appearance in the frontal region on this lateral skull radiograph



**Fig. 32.173:** Thalassaemia. Radiograph of the left hand demonstrates widening of the medullary cavity and thinning of the cortex within the tubular bones

### Sickle Cell Anaemia

The skeletal findings in sickle cell anaemia are similar to those in thalassaemia. The skull changes are less severe.



**Fig. 32.174:** Sickle cell disease. There is central endplate depression within some of the thoracic vertebrae (arrows) due to focal fractures resulting from local vascular occlusion. There is also cardiomegaly due to anaemia

Compression fractures of the spine can occur due to loss of bony support resulting from marrow hypertrophy. Vertebral fractures however can also be due to infarcts involving the blood vessels supplying the central portions of the superior and inferior endplates. This latter feature results in a depression of the central portion of the vertebral endplate.

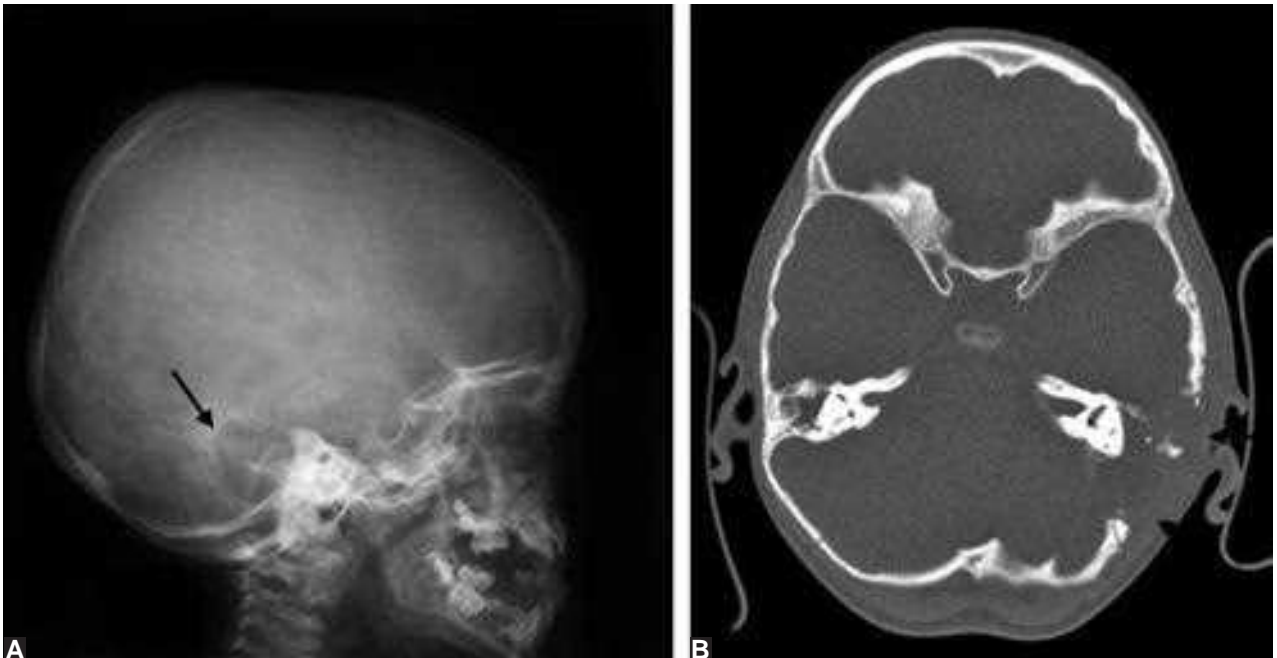
Vascular occlusion due to sickling also results in osteonecrosis in other bones. Diaphyseal or epiphyseal infarcts can occur in the long bones. In young children, the bones of the hands and feet can be affected. This is known as sickle cell dactylitis or hand-foot syndrome. Patients with sickle cell disease are also at risk of osteomyelitis and pyogenic arthritis.

### LANGERHANS' CELL HISTIOCYTOSIS

Langerhans' cell histiocytosis (LCH) in the skeleton can be unifocal or multifocal. The commonest affected site is the skull. Other frequent locations include the femur, ribs mandible, pelvis, and spine.



**Fig. 32.175:** LCH proximal right femur. AP radiograph demonstrates a well-defined, ovoid lytic lesion in the proximal right femur. The margins of the lesion are slightly sclerotic. There is cortical expansion and periosteal reaction



**Figs 32.176A and B:** LCH of skull. (A) Lateral skull radiograph shows a large, well-defined lytic lesion within the temporal bone region of the skull (arrow); (B) Axial CT scan through the skull on bone window settings. This confirms the presence of an extensive destructive process involving the left petrous temporal bone (arrows)

Langerhans' cell histiocytosis lesions in the skull are usually well-defined lytic lesions with sharp margins. In the spine, the disease causes lytic destruction and collapse of the vertebral body. Elsewhere in the skeleton, LCH lesions are usually well-defined with minimally sclerotic borders.

## PAEDIATRIC BONE TUMOURS

### Osteoid Osteoma

The osteoid osteoma is a painful lesion, with patients classically complaining of night pain. The commonest sites for osteoid osteoma are the femur and tibia. The typical



**Figs 32.177A and B:** Osteoid osteoma of the left tibia. (A) AP radiograph of left lower leg demonstrates dense sclerosis and focal cortical thickening along the medial aspect of the proximal left tibia; (B) The lateral radiograph shows the small radiolucent nidus within the bony lesion (arrow)



**Fig. 32.178:** Osteoid osteoma on radionuclide bone scan. Image taken from the front shows increased tracer uptake medially within the proximal right tibia which corresponds to the sclerotic component of the lesion. The smaller more focal area of intense uptake corresponds to the nidus (arrow)

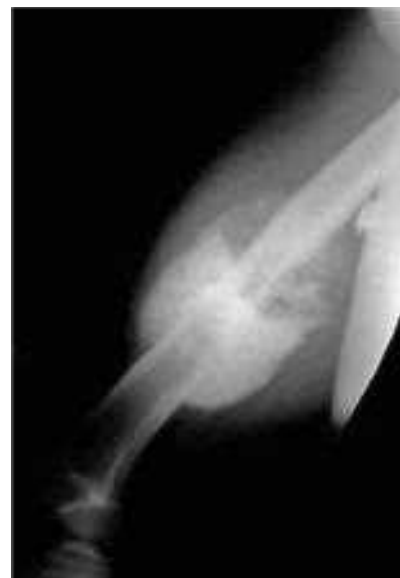
radiographic appearance is a cortically based sclerotic lesion in a long bone, which has a small lucent area within it known as the nidus.

### OSTEOSARCOMA

Osteosarcomas can occur anywhere in the skeleton. Frequently encountered sites are the distal femur, proximal tibia, proximal humerus and pelvis. Long bone tumours usually arise from the metaphysis. On X-ray, a typical osteosarcoma is identified as a mixed lytic and sclerotic lesion involving



**Figs 32.179A and B:** Osteosarcoma of distal left femur. (A and B) AP and lateral radiographs of left knee show a sclerotic lesion arising from the distal left femoral diaphysis. Spiculated periosteal reaction is present (white arrow) and there is also elevated periosteal reaction (Codmans triangle) at the superior margin of the lesion (white arrow)



**Fig. 32.180:** Osteosarcoma of femur. Lateral view of the femur shows marked-sunray-periosteal new bone formation associated with the mid femoral shaft tumour. Osteosarcoma was confirmed pathologically at biopsy



the long bone metaphysis. There is usually cortical erosion and destruction, often with a spiculated 'sunburst' periosteal reaction. Elevated periosteal reaction is also demonstrated at the tumour extremities (Codman's triangle).

### Ewing Sarcoma

The commonest site for Ewing sarcoma is the long bone diaphysis. Flat bones (pelvis and ribs) are also commonly involved.

The typical radiographic appearance of Ewing sarcoma is a 'moth eaten' lesion (due to multiple small holes) in the diaphysis or, less commonly, the metaphysis of a long bone. There is usually an 'onion skin' type of periosteal reaction.



**Fig. 32.181:** Ewing sarcoma left femur. AP and lateral radiographs show a mixed lytic and sclerotic lesion in the diaphysis of the left femur resulting in a 'moth-eaten' appearance. There is 'onion-skin' type periosteal reaction (arrow)

### Non-accidental Injury

#### *Skeletal Findings:*

- Multiple fractures in varying stages of healing
- Diaphyseal fractures, especially in the non-ambulatory infant/child
- Metaphyseal fractures: The classic metaphyseal fracture is often described as a corner or bucket-handle fracture
- Rib fractures: Posterior rib fractures have a higher specificity for inflicted injury than anterolateral fractures
- Scapula fracture: Fracture of the acromion is highly specific for abuse
- Spinal fractures
- Skull fractures.

Other types of injury encountered in this situation include intracranial and visceral trauma.



**Fig. 32.182:** Frontal chest radiograph shows healing posterior rib fractures involving the left seventh, eighth and ninth ribs (arrows)



**Fig. 32.183:** Lateral view of ankle demonstrates metaphyseal corner fractures of the distal tibia (arrows)

## PAEDIATRIC RENAL IMAGING

### CONGENITAL ANOMALIES

#### Ureteral Duplication

Ureteral duplication may be partial or complete. In partial duplication, the ureters unite anywhere along their course and then continue inferiorly as a single structure. In completely

uplicated systems, the two ureters are separate throughout their entire course. The ureter draining the upper moiety usually inserts into the bladder ectopically, below and more medial to the insertion of the ureter, which drains the lower renal moiety. The ectopic ureter is more likely to become obstructed, sometimes due to an associated ureterocele. The lower-moiety ureter is more prone to reflux. When renal function is adequate, duplication of the pelvocalyceal system and ureter can be visualised on excretion urography. It is sometimes difficult to establish if the ureteric duplication is partial or complete on this study.



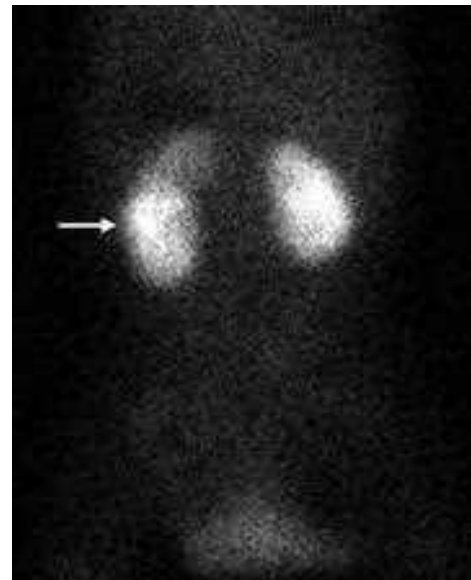
**Fig. 32.184:** Left-sided upper ureteric duplication. Excretory urogram shows two left-sided pelvocalyceal systems (arrows). The separate proximal ureters are visible. There is a filling defect in the left side of the bladder due to a ureterocele (arrowhead). This is causing some obstruction to the upper renal moiety which demonstrates clubbing of its calyces



**Fig. 32.185:** Uncomplicated ureteral duplication. Parasagittal ultrasound scan of left kidney shows two echogenic renal sinuses (arrows). The kidney is also enlarged. These findings are typical for an uncomplicated duplex kidney



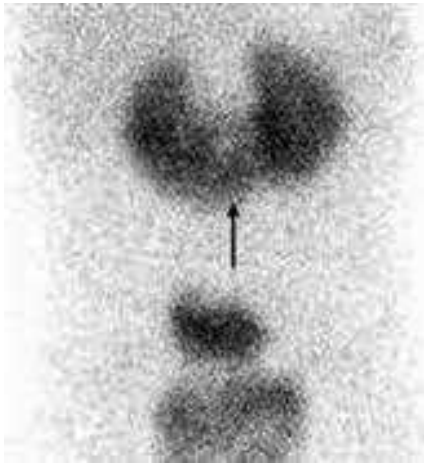
**Fig. 32.186:** Ureteral duplication with obstructed upper renal moiety. Longitudinal ultrasound scan of left kidney shows a hydronephrotic upper moiety renal pelvis (white arrow) and its associated hydroureter (white arrows)



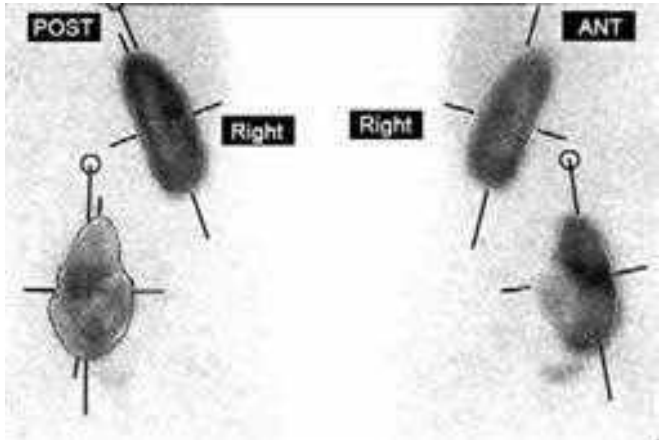
**Fig. 32.187:** Duplex left kidney. Renal radionuclide study using technetium 99 m dimercaptosuccinic acid (DMSA). This image taken from the back, shows an enlarged left kidney consistent with a duplex kidney (arrow)

### Horseshoe Kidney

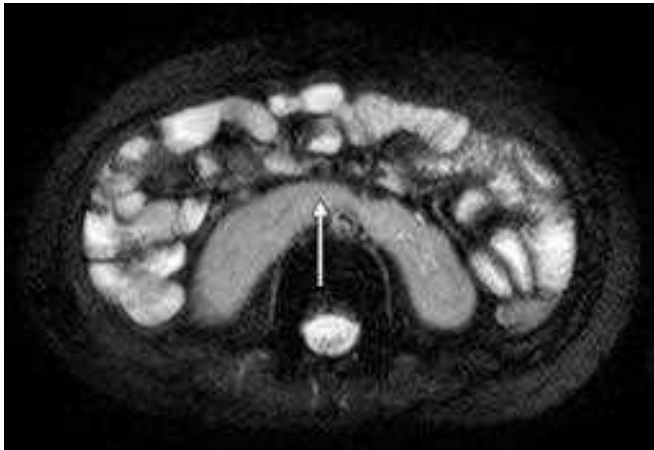
The horseshoe kidney arises because of fusion of the lower poles of the kidneys across the midline. This fusion produces an abnormal renal axis, which may be detected on ultrasound. The fused portion of the kidney (known as the isthmus) may also be visualised on ultrasound as renal tissue which overlies the spine. The horseshoe kidney is best demonstrated in its entirety on renal scintigraphy (DMSA scan) and abdominal CT or MR scans.



**Fig. 32.188:** Horseshoe kidney. DMSA scan demonstrates uptake within both kidneys and within the renal isthmus (arrow)



**Fig. 32.190:** Pelvic kidney on DMSA scan. The right kidney is located in a normal position. The left kidney is ectopic, lying within the pelvis



**Fig. 32.189:** Horseshoe kidney on abdominal MR scan. Axial T2-weighted (fat saturated) image demonstrates fusion of the lower poles of the kidneys anterior to the spine (arrows)



**Fig. 32.191:** Pelvic kidney. Coronal T2-weighted MR scan shows an ectopic left kidney above the bladder (arrow). The renal pelvis and calyces are dilated

## RENAL ECTOPIA

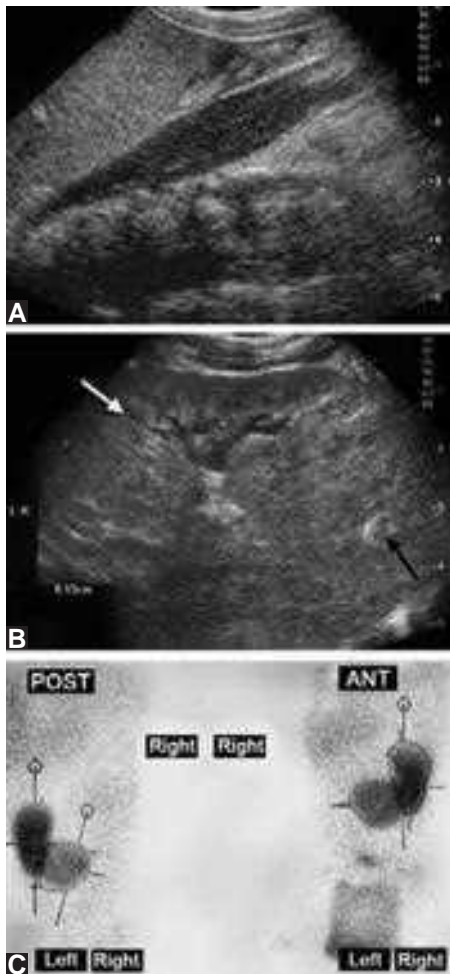
### Ipsilateral Renal Ectopia

In the foetus, the normal migration of the kidney from the pelvis to the renal fossa may become interrupted. Consequently the kidney can be located anywhere along the migrational path. When a kidney cannot be found in its usual position on ultrasound, the pelvis should be closely scrutinised to see if there is an ectopic pelvic kidney. Pelvic kidneys are more prone to vesicoureteric reflux than normal kidneys. They have an abnormal rotation and are also more likely to have ureteropelvic junction obstruction.

### Crossed Fused Renal Ectopia

This is a condition where the bulk of both kidneys are on one side of the spine. Part of the ectopic kidney may extend across the spine. The ectopic kidney is usually smaller than normal and malrotated. It usually lies below the normally-sited kidney. The kidneys are usually fused and surrounded by a common renal fascia; hence the given term crossed fused renal ectopia. The ureter from the ectopic lower kidney usually crosses the midline to insert into the bladder in its normal position.

Abdominal ultrasound will reveal an empty renal fossa on one side and an apparently enlarged kidney on the other side, with two renal sinuses. The ectopic kidney is generally



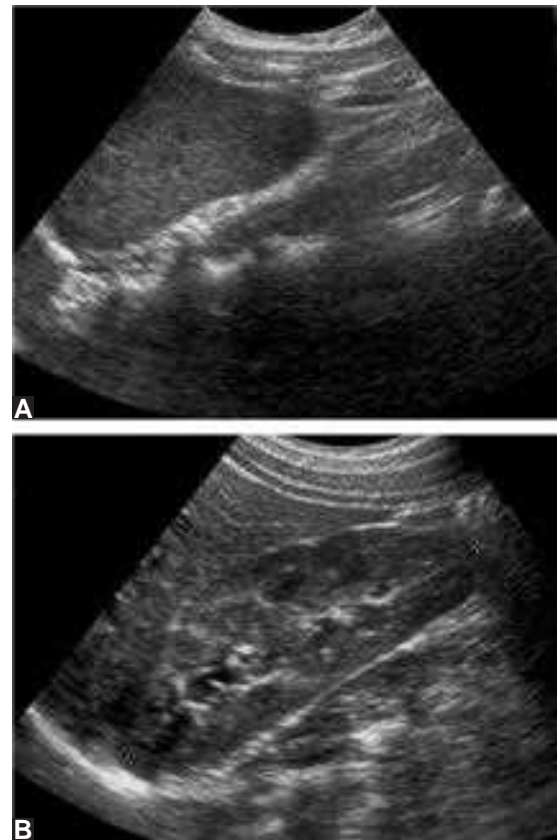
**Figs 32.192A to C:** Crossed fused renal ectopia. (A) Parasagittal ultrasound scan of right flank shows absent right kidney; (B) Parasagittal scan of left flank shows a normally positioned left kidney (white arrow) with an apparent mass of renal tissue at its lower pole (black arrow). This is the ectopic right kidney; (C) DMSA renal scan demonstrates the ectopic right kidney lying medially and horizontally, attached to the lower pole of the left kidney

positioned medially, extending anteriorly across the spine. Nuclear scintigraphy can also be used to confirm the presence of crossed fused renal ectopia.

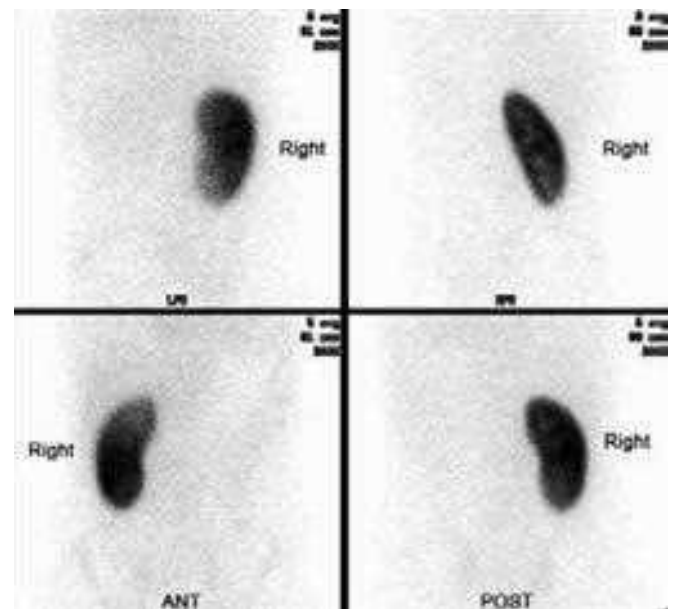
### Renal Agenesis

Bilateral renal agenesis is a lethal anomaly. If the diagnosis is not made until birth, the infant will have features of Potter's sequence. A renal ultrasound scan in the early neonatal period usually confirms the diagnosis by showing no renal tissue in the renal flanks or in an ectopic location.

Unilateral renal agenesis is sometimes detected antenatally or on postnatal ultrasound because of anomalies elsewhere. It is also associated with anomalies of the genital tract.



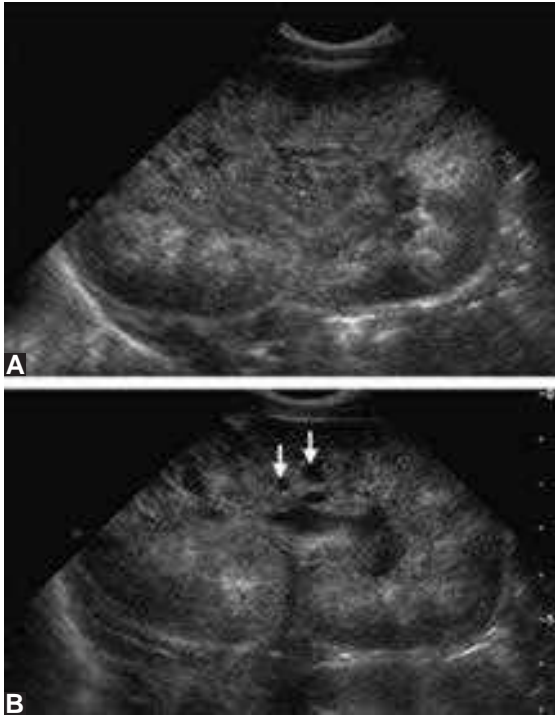
**Figs 32.193A and B:** Agenesis of left kidney. (A) Left parasagittal ultrasound scan shows no kidney in the left flank; (B) Right parasagittal ultrasound scan demonstrates a normal appearing right kidney which is larger than usual due to compensatory hypertrophy



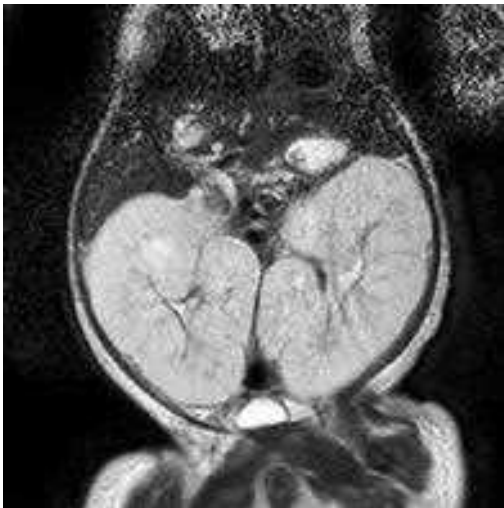
**Fig. 32.194:** Agenesis of left kidney. Radio-isotope study (DMSA) shows a solitary right kidney. No left kidney or ectopic renal tissue is identified

### Autosomal Recessive Polycystic Kidney Disease

This is a rare disorder involving both kidneys and the liver. The disease causes ectasia of the renal collecting tubules and this is manifest pathologically as numerous tiny cysts in the cortex and medulla.



**Figs 32.195A and B:** Autosomal recessive polycystic kidney disease in a newborn infant. (A) Longitudinal ultrasound scan of right kidney demonstrates a markedly enlarged, echogenic kidney; (B) Longitudinal ultrasound scan of the left kidney also shows an enlarged, echogenic kidney. There are a few small discrete cysts within the renal parenchyma (arrows)



**Fig. 32.196:** Autosomal recessive polycystic kidney disease on abdominal MR scan. Coronal T2-weighted abdominal MR image from the same patient, shows the extent of the bilateral nephromegaly

The ultrasound appearances of autosomal recessive polycystic kidney disease in neonates are bilateral enlarged kidneys which are diffusely echogenic. Discrete small cysts may be visible.

### Multicystic Dysplastic Kidney

Multicystic dysplastic kidney is a severe form of renal dysplasia which is associated with obstruction of urinary drainage on the affected side, probably occurring in utero. The sonographic features of classic multicystic dysplastic kidney are multiple cysts of variable size which do not communicate with each other. There is absent or dysplastic renal parenchyma and no renal pelvis is identified. There is no function in a multicystic dysplastic kidney.



**Fig. 32.197:** Multicystic dysplastic kidney. Longitudinal ultrasound image of the left kidney reveals several cysts of different size within the kidney. The cysts are non-communicating. No normal renal parenchyma is identified



**Fig. 32.198:** Multicystic dysplastic kidney. DMSA study performed in the same patient. This image, taken from behind, shows tracer uptake only in the normal right kidney. There is no uptake in the dysplastic left kidney

## URINARY TRACT STONES AND NEPHROCALCINOSIS

### Urinary Tract Stones

Causes of renal tract stones in children include:-

- Infection
- Developmental anomalies of the urinary tract
- Immobilisation
- Metabolic disorders such as hypercalcaemia and hypercalciuria
- Idiopathic.

Calcium stones are radiopaque and therefore can be identified on X-ray. Cystine stones are poorly opaque. Uric acid stones are radiolucent.



**Fig. 32.199:** Bladder calculus. AP radiograph shows a large, radiopaque structure projected over the pelvis, consistent with a bladder calculus (arrow)



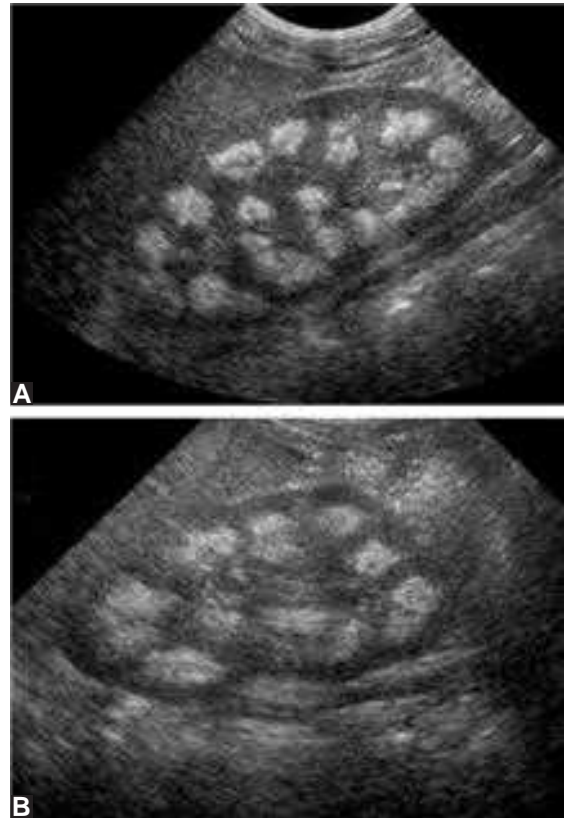
**Fig. 32.200:** Calculus within lower pole of the left kidney. Longitudinal ultrasound scan of left kidney shows a bright (hyperechoic) structure at the lower pole of the kidney (arrow), consistent with a small renal calculus

### Nephrocalcinosis

Nephrocalcinosis is the deposition of calcium in the renal medulla or cortex. Calcium deposition is more common in the medulla than in the cortex.

Causes of medullary nephrocalcinosis include:

- Hyperparathyroidism
- Renal tubular acidosis
- Medullary sponge kidney
- Causes of hypercalcaemia or hypercalciuria
- Hyperoxaluria
- Frusemide.



**Figs 32.201A and B:** Medullary nephrocalcinosis. (A and B) Longitudinal ultrasound images of right and left kidneys respectively. The renal pyramids are markedly hyperechoic due to medullary calcinosis

### DILATATION OF URINARY TRACT

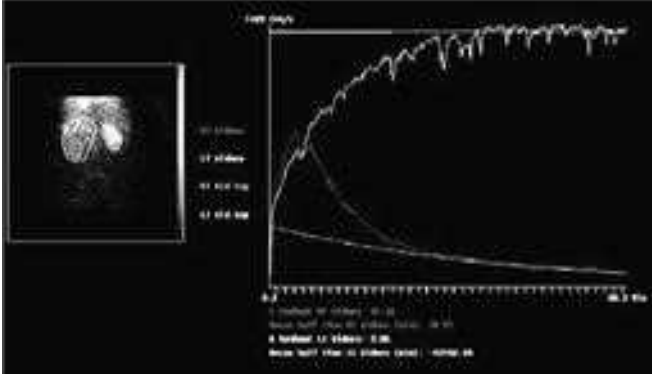
Dilatation of the urinary tract can be due to one of three general problems:

- Obstruction
- Vesicoureteric reflux
- A combination of both.

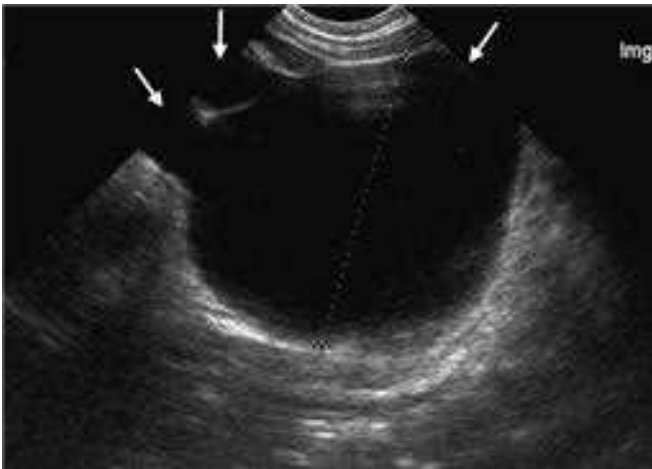
Ureteropelvic Junction Obstruction

Ureteropelvic junction (UPJ) obstruction is the most common cause of upper urinary tract obstruction in infants and children.

The characteristic ultrasound findings include dilated calyces with a moderate or large renal pelvis. The renal parenchyma is of varying thickness depending on the degree of pelvocalyceal dilatation. Diuretic renography is commonly performed to assess UPJ obstruction.



**Fig. 32.202:** Left-sided ureteropelvic obstruction. On this diuretic renogram study using technetium-99m mercaptoacetyltriglycine (MAG 3), there is normal excretion of radioisotope from the right kidney. There is no excretion of radioisotope from the left kidney, even after the administration of frusemide at 20 minutes



**Fig. 32.203:** Ureteropelvic junction obstruction. Longitudinal ultrasound scan demonstrates markedly dilated renal pelvis and moderately dilated calyces (arrows)

### Posterior Urethral Valves

Posterior urethral valves are the most common cause of urethral obstruction in males and the diagnosis is usually confirmed with a micturating cystourethrogram. The features of posterior urethral valves on this study are:-

- Dilated posterior urethra
- Visualisation of valves
- Trabeculated bladder with wide neck
- Usually reflux of contrast into dilated, tortuous ureters.



**Fig. 32.204:** Posterior urethral valves. Micturating cystourethrogram study after urinary catheter removed. There is a filling defect in the posterior urethra due to posterior urethral valves (arrow). The posterior urethra proximal to this is dilated and the bladder neck is wide. There is reflux of contrast into both ureters

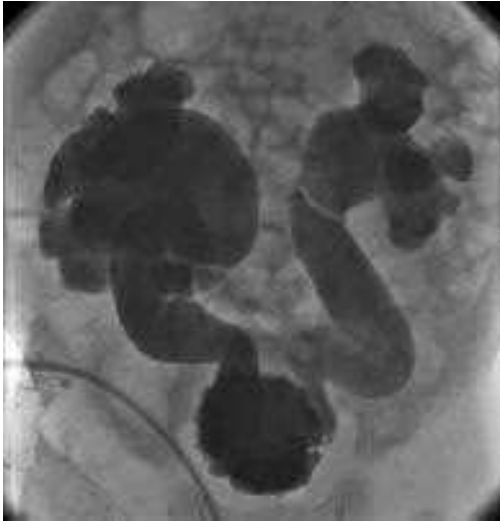
### Vesicoureteric Reflux

The severity of vesicoureteric reflux is graded according to the degree of upper renal tract dilatation on the micturation cystourethrogram:

- Grade 1: Reflux into ureter only
- Grade 2: Reflux into ureter, renal pelvis and calyces which are preserved



**Fig. 32.205:** Bilateral grade 2 vesicoureteric reflux. Micturating cystourethrogram study demonstrates reflux of contrast into the pelvocalyceal system and ureter bilaterally. The calyces are preserved

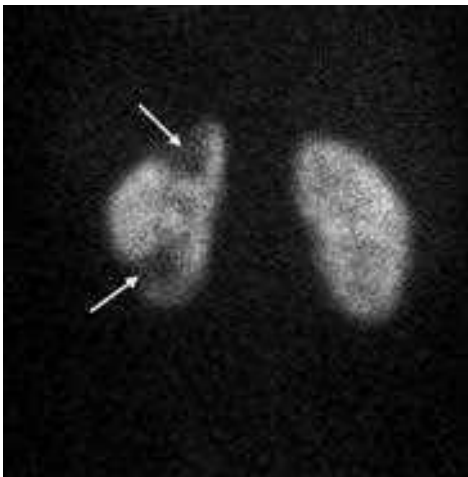


**Fig. 32.206:** Severe bilateral vesicoureteric reflux. There is grade 5 reflux on the right. The right ureter is dilated and tortuous. There is marked dilatation of the right pelvocalyceal system with severe calyceal blunting. The appearances are slightly less marked on the left side and represent grade 4/5 vesicoureteric reflux

- Grade 3: Reflux into mildly dilated ureter and renal pelvis; the calyces are slightly blunted
- Grade 4: Reflux into moderately dilated ureter and renal pelvis; moderately blunted calyces
- Grade 5: Reflux into tortuous dilated ureter and markedly dilated renal pelvis; severe calyceal blunting.

### Renal Tract Infection

Urinary tract infection can involve the kidney, bladder or both areas. The role of imaging in the child with a proven urinary tract infection is to diagnose underlying conditions which predispose to infection such as hydronephrosis and reflux, and to detect renal scarring.



**Fig. 32.207:** Cortical scarring left kidney. This DMSA study reveals photopenic areas (arrows) in the upper and lower poles of the left kidney, consistent with renal cortical scarring. The right kidney is normal

The ultrasound scan often appears normal in uncomplicated cases of pyelonephritis. Renal cortical scarring is usually detected using renal scintigraphy.

## NEOPLASTIC DISEASES

### Wilms' Tumour

Wilms' tumour is the commonest abdominal malignancy of childhood. Radiologic examinations help to stage the disease in order to assist surgical planning and treatment, and to evaluate response to treatment. The tumour is usually identified as an intrarenal mass. It can extend via the renal vein into the inferior vena cava and right atrium and it can metastasise to the lungs. Bilateral Wilms' tumours can occur.

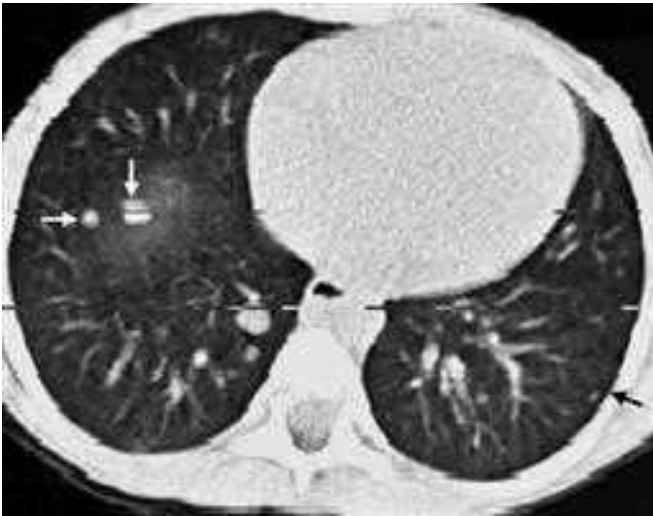


**Fig. 32.208:** Wilms' tumour of the left kidney. Contrast-enhanced axial CT scan through the abdomen demonstrates a large mass arising from the left kidney. There is a thin rim of normal renal parenchyma around the tumour anteriorly (arrow)



**Fig. 32.209:** Bilateral Wilms' tumour (stage V). Coronal T2-weighted scan (fat saturated) shows a bilobed mass within the left kidney. There is normal left renal tissue laterally (arrow). There is a smaller mass within the right kidney (arrow)





**Fig. 32.210:** Lung metastases from Wilms' tumour. Axial CT scan through the chest on lung window settings. There are a number of intrapulmonary nodules within both lungs on this image (some of which are arrowed), consistent with intrapulmonary metastases

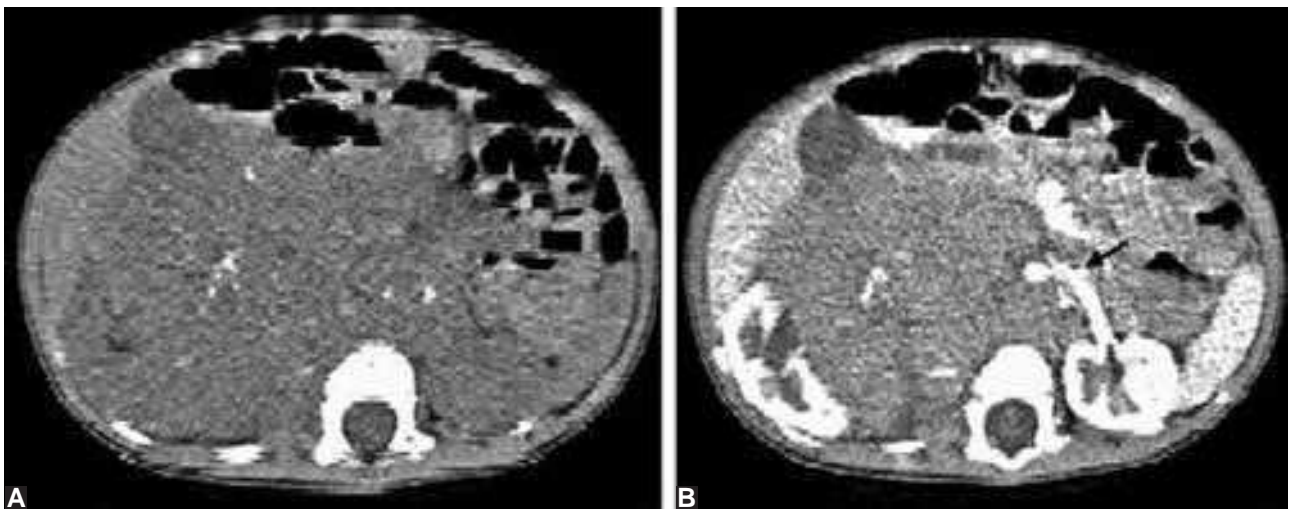
Where possible, an MR scan of the abdomen should be used to stage Wilms' tumour since this avoids ionising radiation. CT scanning however is required to image the chest.

### Neuroblastoma

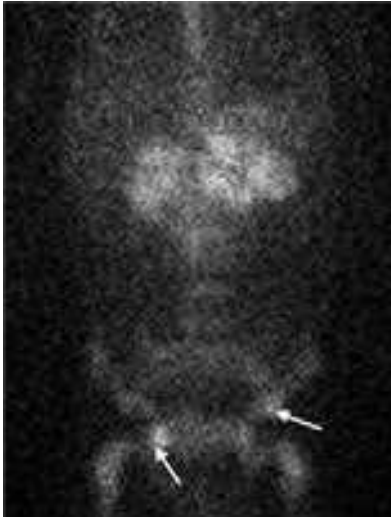
Among paediatric abdominal neoplasms, neuroblastoma is the second most common after Wilms' tumour. Neuroblastomas which arise within the abdomen are staged with an abdominal



**Fig. 32.211:** Right adrenal neuroblastoma. Coronal T2-weighted (fat saturated) MR scan of abdomen demonstrates an ovoid mass situated above the upper pole of the right kidney in the right adrenal gland (arrow)



**Figs 32.212A and B:** Right adrenal neuroblastoma with nodal metastases. (A) Unenhanced axial CT scan through the upper abdomen demonstrates a large low density mass in the right flank which crosses the midline. The mass contains small areas of increased density, which are flecks of calcium. This is a feature in up to 90% of tumours on CT scanning; (B) Contrast-enhanced axial CT scan through the same region shows the conglomerate mass of tumour and retroperitoneal lymphadenopathy. The lymphadenopathy is displacing the aorta and left renal artery anteriorly (arrow)



**Fig. 32.213:** Abdominal neuroblastoma with metastases on MIBG scan. There is increased tracer uptake in the upper abdomen at the site of the tumour and nodal disease. There are also other areas of increased uptake in the pelvis, consistent with skeletal metastases

MR scan (where possible) and a CT scan of the chest. Neuroblastomas arising from the adrenal gland can invade the adjacent kidney. The tumour spreads to lymph nodes, bone, bone marrow, liver and skin. Bone metastases are best identified with radionuclide bone studies.

I-131-metaiodobenzylguanidine (MIBG) scintigraphy assesses functional uptake by the tumour and metastases.

### ACKNOWLEDGEMENTS

The authors are grateful to Dr Ruth Allen, Consultant Paediatric Radiologist, Dr Greg J Irwin, Consultant Paediatric Radiologist, Dr Andrew J Watt, Consultant Paediatric Radiologist, Mr Rod Duncan, Consultant Orthopaedic Surgeon and Mrs Morag Attaie, Lead Sonographer at Royal Hospital for Sick Children, Glasgow for providing some images.

# Paediatric Maxillofacial Surgery

## INTRODUCTION

Although the maxillofacial area is relatively small at birth in relation to the head and cranium, its development started in the embryo at around 4 weeks. All the facial parts are fully developed at birth but are small but rapidly grow in size during the first year of life (Fig. 33.1). The maxillofacial area is complex because it involves the airway, deglutition, mastication and the dentition. Developmental anomalies, particularly clefting defects are not uncommon and they involve not only the lip and palate but may relate to orbits, nose and early developmental failure of fusion of

the branchial arches as well as malformations of the skull related to craniosynostosis. They also may involve the eyes and ears. Interference with growth and neurological function of the cranial nerves not infrequently occurs and because the face is always visible with facial expression and oral function is affected, when appearance is abnormal there is a major problem for the child and family, often with significant psychological effects on the child especially when there is interference with speech, hearing, vision and aesthetics are affected. Normal development of the dentition is very important to the child for mastication, speech and aesthetics.

The principal areas in which the maxillofacial surgeon can be of help to the child, family and paediatrician will be in the management of:

- Congenital deformities with cleft lip and palate followed by craniofacial microsomia (CFM) and craniosynostotic deformity where the face is significantly affected. There are many other rarer syndromic and non-syndromic deformities which present with aesthetic and functional problems, the majority of which when severe will require maxillofacial surgery.
- Trauma in the maxillofacial area is another major problem especially in the developing world where childcare is more difficult. Management of maxillofacial trauma especially for children often occurs late after healing has started to occur. The mid-face is relatively small at birth, but as the paranasal sinuses develop and increase in size there is an increased risk of trauma but even then it tends to affect principally the mandible and frontal areas during the first few years of life. Management of fractures affecting the mandible and maxillae is complicated by the presence of developing teeth in the mandible as well as in the mid-face. Minor discrepancies in the position of jaw fragments are normally self-correcting with growth except in the naso-orbital area.
- Infection in the head and neck area is not uncommon

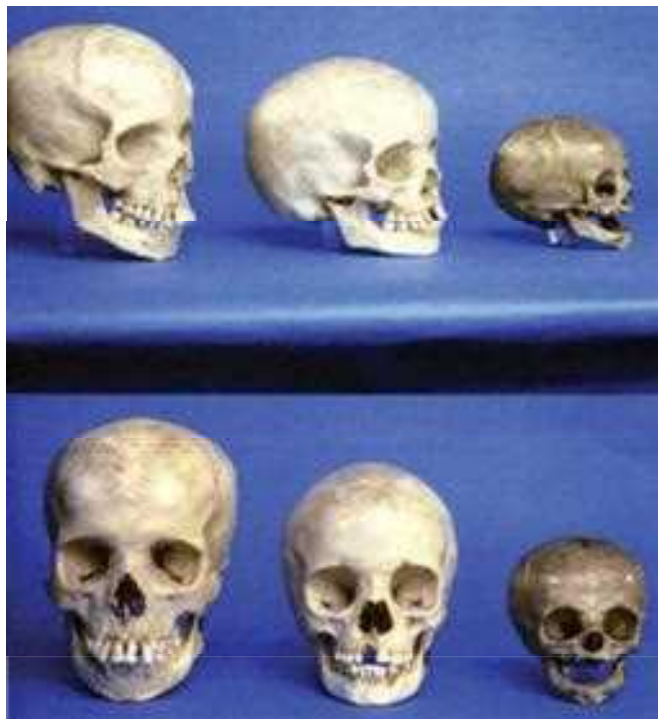


Fig. 33.1: Oblique view/AP view of dry skulls of various ages: 6

developing world where caries and poor oral hygiene are commonplace. Life-threatening spread of infection may occur from the oral cavity into the pharynx with lethal consequences if not well-managed by the surgeon.

- Maxillofacial pathology and oral manifestations of systemic disease often present in the face with characteristic stigmata as well as in a unique way in the oral cavity and pharynx. Early recognition is helpful as this is an accessible area and easily visible to the clinician. There are a variety of benign and malignant tumours which may present in the head and neck and many of the commoner ones are associated with the teeth as well as other dysplastic conditions peculiar to the jaws and oral mucosa. Oral ulceration is common and various dermatological conditions present characteristically in the oral cavity.
- The age of the child is an important factor as growth may be rapid, for example, with bony lesions, e.g. cherubism and vascular anomalies. Others involute and cease as growth completes. With discrepancies in jaw size and some bone dysplastic conditions it may then become worthwhile to wait until growth has ceased before correcting those deformities. Other conditions require early correction otherwise normal growth may be affected when the temporomandibular joints are involved. When conditions such as aggressive fibromatosis and cystic hygromata present they require early major surgical procedures to reduce the risk of residual deformity (Box 33.1) and involvement of the airway or major neck vessels.

#### Box 33.1: Paediatric maxillofacial surgery

##### *Favourable aspects*

- Good blood supply
- Rapid healing
- Growth adaptation of bone form and occlusion.

##### *Unfavourable aspects*

- Small dimensions
- Bone weakness
- Close location of tooth buds and inferior dental and infraorbital nerves
- Interference with growth.

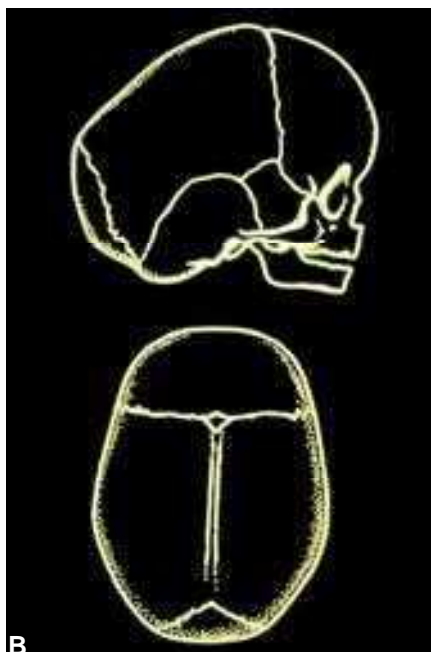
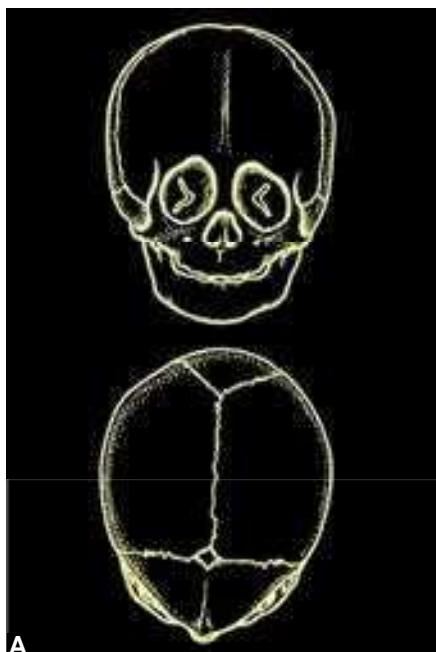
## CONGENITAL DEFORMITY

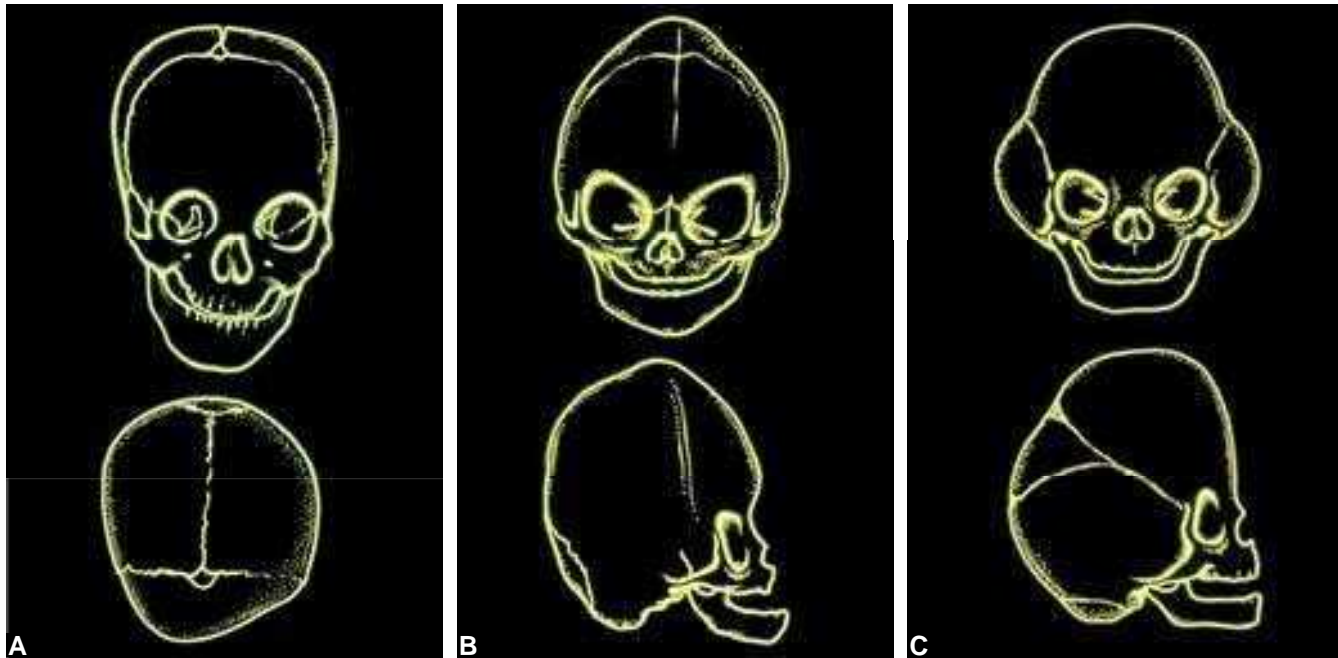
### Craniofacial Deformity

After cleft lip and palate probably the most important conditions to consider are the craniosynostotic deformities (Box 33.2.1). These primarily affect the cranium but when the base of skull is involved growth of the mid-face is impeded. Premature fusion of the sutures may occur prior to birth and when a single suture is affected such as the sagittal suture an increase in length of the head (dolichocephaly) will occur with growth of the brain continuing until approximately 15 months postpartum (Figs 33.2A to C and 33.3A to C). If the coronal suture is affected then

#### Box 33.2.1: Craniofacial deformity

- Craniosynostosis and related syndromes
- Craniofacial clefting defects
- Craniofacial microsomia
- Treacher-Collins syndrome
- Other malformations.





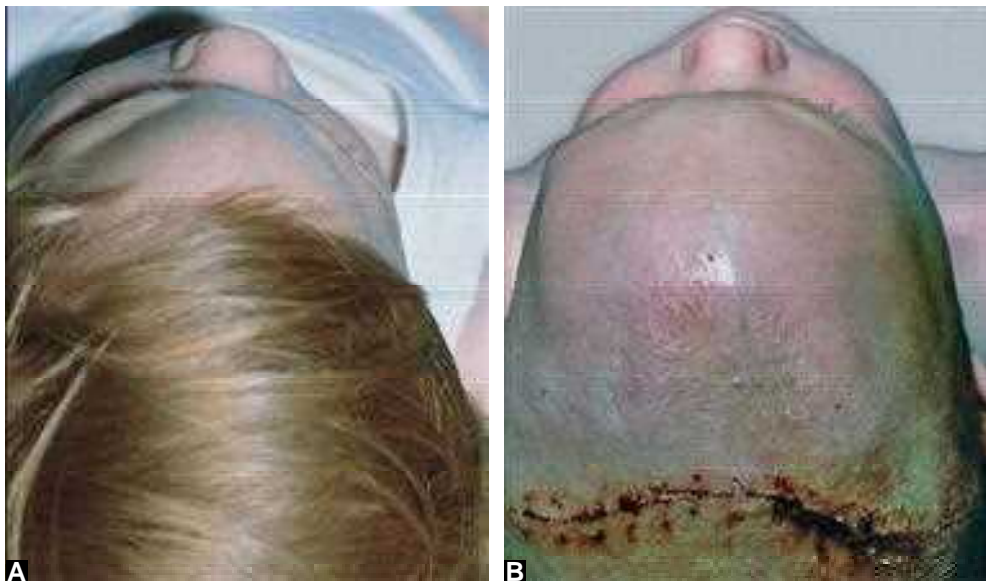
**Figs 33.3A to C:** Craniosynostosis: (A) Plagiocephaly; (B) Coronal; (C) Kleeblattschädel



**Fig. 33.4:** Plagiocephaly—facial deformity—unilateral right coronal synostosis

there tends to be a brachycephalic deformity and various combinations of premature fusion will result in abnormal cranial development, for example, with early fusion of the coronal and sagittal suture, there is likely to be a degree of turricephaly and when just one-half of a coronal suture

growth of the face (plagiocephaly) (Figs 33.4 and 33.5A and B). Growth will cause deviation of the face towards the unaffected side which is particularly difficult to correct at a later stage, whereas if release of the suture can be achieved before 1 year of age, this deformity can be circumvented



**Figs 33.5A and B:** Metopic synostosis correction

**Box 33.2.2:** Plagiocephaly—unilateral coronal synostosis

*Features*

- Axis of cranium altered
- Recession of affected supraorbital ridge
- Altered shape of orbit
- Nose deviates to unaffected side
- Maxilla larger—affected side.

*Treatment*

- Bilateral release of coronal suture
- Asymmetric frontal advancement
- Supraorbital ridge advancement
- Surgery at 6 months or weight of 5 kg.

**Box 33.3:** The commoner craniofacial dysostoses encountered

- Crouzon syndrome
- Apert syndrome
- Saethre-Chotzen syndrome
- Carpenter syndrome
- Pfeiffer syndrome
- Kleeblattschadel anomaly.

example, when associated with Crouzon syndrome there is also premature fusion occurring in the cranial base this results in severe underdevelopment of the mid-face which is accompanied by proptosis of the eyes, often a degree of hypertelorism and a very short retruded mid-face height. Early release of the affected cranial sutures will allow the brain to grow normally and will improve the appearance of the skull but it has little effect on the development of the mid-face (Figs 33.6A to D). It is difficult to provide a good early correction of the mid-face deformity by an advancement of that and where possible if not too severe

this is best corrected towards the end of the growth period. However, if the deformity is gross then correcting it at around 10–12 years of age is often necessary and prevents the child from being teased or bullied at school, which is particularly likely to occur when moving from primary to secondary education. If there is a residual discrepancy in size this may be treated, again towards the end of the growth period with mid-face osteotomies (Figs 33.7A and B) usually at the Le Fort III level (Figs 33.8A to C).

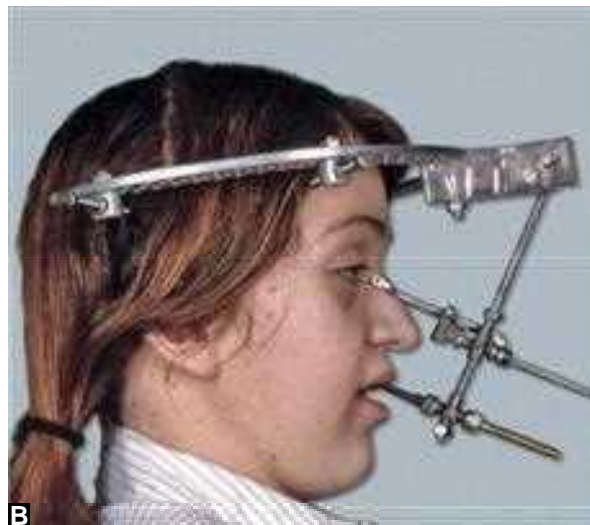
The same is true for some of the other syndromic conditions such as Apert (Fig. 33.9) and Pfeiffer syndromes. These are accompanied by digital deformities and have a different appearance from Crouzon syndrome. Other rarer anomalies, such as Saethre-Chotzen and Carpenter syndromes, have similar facial deformities. Very often these are accompanied by a degree of hypertelorism and sometimes by a clefting defect in the orbital and mid-face areas. The initial correction of the cranial deformity often makes the facial deformity look worse as the cranial cavity tends to expand forwards with release of the coronal suture but the mid-face is left behind due to the premature base of skull fusion. Both corrections may now be achieved with surgery towards the end of the growth period. This may be either sub-cranial or where it involves also the forehead and vault of the skull, this can be corrected also as a craniofacial procedure with advancement of the mid-face and frontal bones. At the same time, in some cases where the mid-face is short in height then this can be increased by a low level osteotomy involving the dentoalveolar complex at the Le Fort I level. This will also achieve often a better dental occlusion. The lower half of the maxilla can be stabilised



**Figs 33.6A to D:** Crouzon deformity—early treatment and late result



**Figs 33.7A and B:** Le Fort III sub-cranial (red) and trans-cranial (blue) and Le Fort (green) osteotomies



**A**

**B**

**C**



Fig. 33.9: Apert deformity

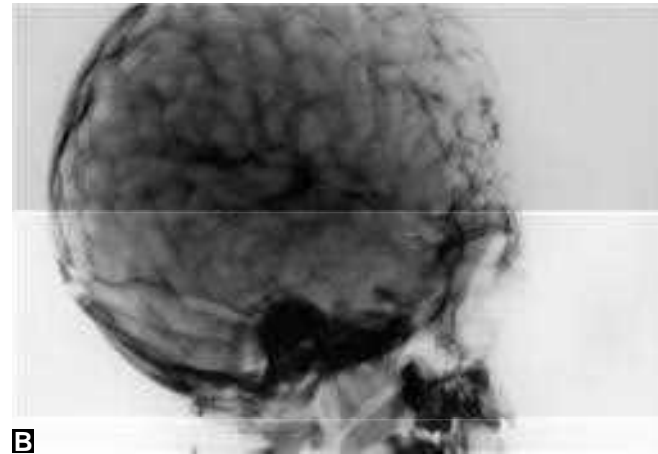
with small bone plates and the defect filled in with a cranial bone graft. Generally speaking in the older child the aim will be to correct finally all deformity problems with one single procedure. Another troublesome feature may be obstructive sleep apnoea when this is presenting, advancement of the mid-face at the Le Fort III level will relieve this and avoid the necessity for a long-term tracheostomy. Gross ocular proptosis likewise is a strong indication for early surgery if vision is at risk especially if there is any tendency for the lids to close behind the globes. Similarly, if there is a tendency to raised intracranial pressure with pansynostosis, further advancement of the frontal bone with release of all the major sutures and with skull expansion may be necessary (Figs 33.10A to C). Occasionally a permanent shunt will be required.

### Craniofacial Clefting Defects

Most of these clefts are rare. In the midline of the face, they are usually associated with meningoencephalocoeles (Figs 33.11A to D) and involve the orbits and nasoethmoid complex and result in hypertelorism. Transcranial approach is required for treatment in most cases but a few milder forms may be treated sub-cranially.

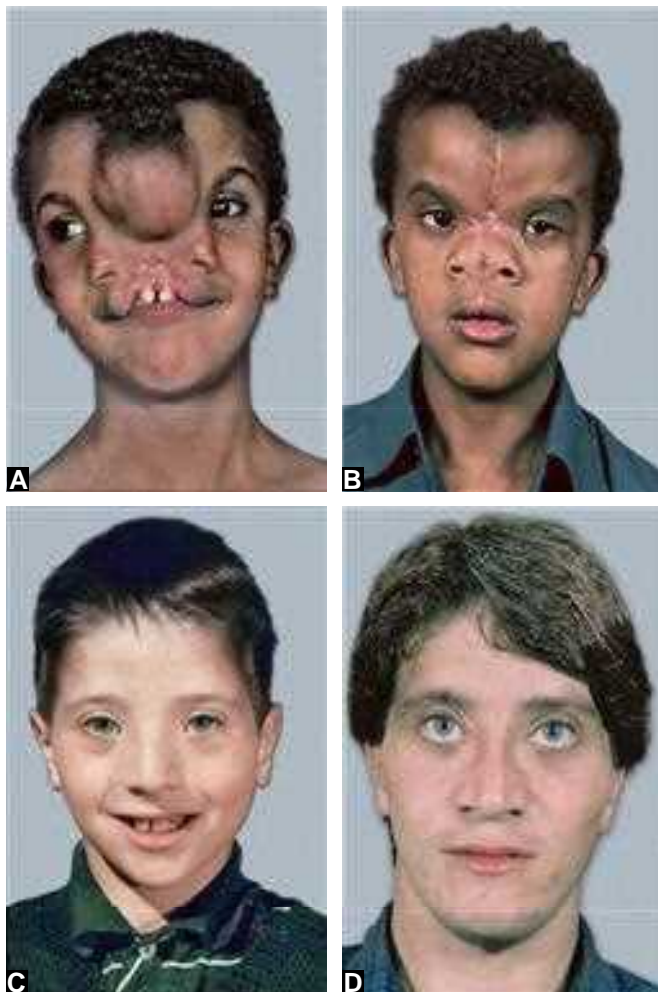
### CRANIOFACIAL MICROSOMIA

This is typically a combined first and second branchial arch defect which is thought to result from a failure of the neuroectoderm to migrate. It has been shown experimentally in mice that haemorrhage from the primitive stapedia artery



Figs 33.10A to C: Pansynostosis—copper beaten skull deformity prior





**Figs 33.11A to D:** (A and B) Hypertelorism with encephalocele corrected, viewed 2 years later (for further surgery); (C and D) Mild hypertelorism—seen again as an adult

result in defective development of the pinna and middle ear, mandible, parotid gland, temporomandibular joint and muscles of mastication. In severe forms, all these structures will be affected and be either absent or rudimentary. The mid-face sometimes will also be affected with a clefting defect into the orbit and posterior maxilla. There will be a conductive deafness on the affected side (Figs 33.12A and B). In the relatively rare bilateral cases, for example, Goldenhar syndrome instead of a gross unilateral asymmetry, there will be bilateral or a symmetrical lack of growth occurring in the lower face. It also may be associated with vertebral defects as well as dermoid cystic lesions in the superolateral orbital areas. Obstructive sleep apnoea may be an indication for early surgery in the severer forms of this condition as it is in craniosynostotic syndromes. There are a number of classifications of CFM which are principally based on the range of defects and the

The cases tend to be sporadic and appear not to have a true genetic basis, less than 1% of parents will have a second affected child and there is a 3% chance of it being passed on. The incidence is variably quoted at 1:3,000–1:5,600, males are more commonly affected. The right side of the face is more frequently affected (Figs 33.12C and D) (Box 33.4).



**Figs 33.12A to D:** (A) Severe hemifacial microsomia (HFM); (B) Goldenhar syndrome; (C) Pre-surgical HFM; (D) 10 years post-surgical

#### Box 33.4: Craniofacial microsomia

- Hemifacial microsomia
- First/second branchial arch syndrome
- Goldenhar syndrome (Oculo-auriculo-vertebral dysplasia)
- Incidence 1:5,600—sporadic, rarely familial
- Second commonest congenital facial anomaly after cleft lip and palate
- Areas affected—craniofacial skeleton, neuromuscular tissues, skin structures, salivary glands, 0.5 branchial arch structures, e.g. ears

## CLINICAL FEATURES

These features can be divided into skeletal and soft tissue

## Skeletal Defects

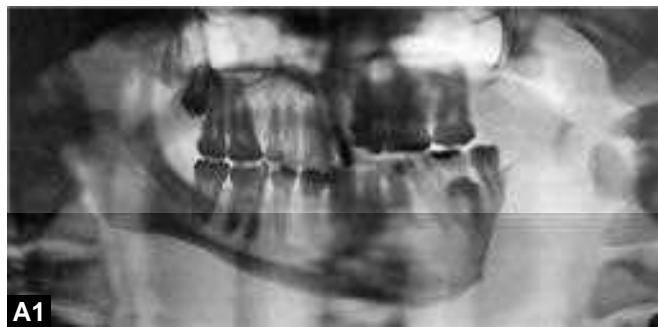
Skeletal defects essentially involve the mandible which on the affected side will be short, narrow and normally retrusive from birth. Increasing asymmetry occurs with growth due to the lack of growth potential on the affected side. In the mildest of cases, there may only be a slight failure of growth but in severe cases the temporomandibular joint and ramus of the mandible will be missing and there is then a three-dimensional (3D) failure of growth on the affected side which is accentuated by the lack of overlying soft tissues, muscles and salivary glands. In the severer forms, there is a failure of vertical growth which affects the maxilla and the chin point will tend to deviate markedly towards the affected side. In addition, there is often hypoplasia affecting the temporal bone with a less prominent mastoid process and an absence of the external ear and external auditory meatus and more rarely major orbital defects on the affected side. Teeth may also be missing posteriorly on the affected side (Figs 33.13A to C).

## Soft Tissue Defects

Soft tissue defects arise from the poor development of the first and second pharyngeal arches. The pinna of the ear may be absent as well as the external auditory meatus. There may be a facial nerve paralysis affecting the muscles of facial expression and there is also absence or poor development of the muscles of mastication on the affected side and a lack of overlying soft tissue accentuated by the absence of the parotid gland in some cases and by the loss of subcutaneous fat. Preauricular skin tags are often present. There is an associated degree of macrostomia at the commissure of the lips on the affected side which is laterally displaced and canted upwards. Usually the trigeminal nerve is unaffected. The external ear deformity varies from a complete absence of the ear and external auditory meatus to a mild degree of hypoplasia and this does not correlate in many cases with the lack of mandibular development. The poor development of the muscles of mastication tends to vary and affects the severity of bone development. The chin and midline is markedly deviated to the affected side. Correction of the mandibular and maxillary skeletal deformity will improve the symmetry and dental occlusion but frequently the lack of soft tissue bulk is accentuated by the stretching and tightness of the soft tissues over the facial bones. In the more severe cases, correction of the soft tissue defect with a microvascular free flap will improve the appearance and the use of muscle flaps and de-epithelialised skin flaps is required for the more severe defects using a composite flap of bone, muscle, fat and skin. In severe cases, excess is usually inserted because atrophy of the muscle tends to occur due its lack of nerve

liposuction at a later stage. Cranial nerve abnormalities most critically affect the facial nerve and at an early stage incompetence of eye closure needs to be checked otherwise following corneal exposure blindness may result. The use of free micro-neurovascular bone or muscle can be helpful and in the older child the use of botulinum toxin may be helpful when given into the muscles of facial expression on the unaffected side, this can improve the symmetry of the face. There may be abnormality of function of the soft palate due to a facial nerve paresis as there is a dual innervation in that area.

It is helpful to consider the classifications of hemifacial microsomia (HFM) in order to standardise treatment. In most cases, the basis of treatment is management of the mandible. The Pruzansky's classification identifies type 1 as a small mandible with a reduced size of the temporomandibular joint and a simple hinge movement. The muscles of mastication are present but small. The type 2 mandible is small, abnormal in shape and has a poorly developed displaced temporomandibular joint and is characteristically subdivided into type 2a the joint is morphologically abnormal and tends to be anteromedially placed in relation to the glenoid fossa. The muscles of mastication are hypoplastic with poor function of the lateral pterygoid. In type 2b, there is no articulation of the condyle and the temporal bone. The coronoid process varies in size and the condyle is rudimentary. The muscles of mastication are deficient and poorly functional. In the severest forms of HFM type 3, there is a complete absence of the mandibular vertical ramus including the condyle and coronoid process. The muscles are very hypoplastic and not attached to the mandible. In type 2, muscle action is not normal but, in type 3, excessive freedom of movement is evident. As far as growth is concerned if HFM is a progressive condition interceptive surgery is worthwhile for the child. Others believe that there is some proportional growth on the affected side. Due to the 3D failure of growth on the affected side, early treatment is advocated for type 1 and type 2a. Distraction osteogenesis is often effective in the ramus of the mandible to increase the size of the ramus and thus allow for growth of the maxilla whereas in type 2b and type 3 grafting of bone into the ramus area and reconstruction of the joint with a costochondral graft together with limited reconstruction of the temporomandibular joint itself is helpful. This may be done from 5 to 7 years of age, other vascularised grafts have also been used for reconstruction but the morbidity associated with that has not been balanced by good growth of the mandible and now with distraction osteogenesis, it is possible to usefully carry-out further surgery on a reconstructed ramus when thought appropriate. To reduce the soft tissue deficiency free—vascularised grafts are often useful in the ramus area (Figs 33.13A to C). Soft tissue reconstruction of the mouth to correct the macrostomia may be carried out early from 1 year



Figs 33.13A to C: Severe HFM types: A1, A2, B1, B2, B3, C1 and C2

As far as reconstruction of the ear is concerned this is frequently possible if there is a rudimentary ear present and this is usually undertaken with rib and costal cartilage. If there is no ear present and no external auditory meatus sometimes it is better to consider a prosthetic reconstruction of the ear which is held in place with osseointegrated implants behind which a bone anchored hearing aid may also be inserted. To correct any residual canting of the dental occlusion a Le Fort I osteotomy of the maxilla may be required once the mandible has been correctly placed but this is usually left until the teenage period. Again sometimes distraction of the affected maxilla is possible and this may avoid further bone harvesting.

To summarise treatment for the HFM child, careful planning is required and surgery should be limited to three or four episodes if at all possible with the final correction towards the end of the growth period. It is essential to correct the vertical position of the ramus of the mandible early so that the maximum amount of unimpeded growth can be achieved for the maxilla as this is often not adequate without additional ramus lengthening surgery. Where there are defects in the orbit and zygomatic bone these can be corrected at the same time as other surgery is being carried out and usually this is in the early teens. To improve the final appearance after insertion of a free flap the use of liposuction is often helpful if over corrected or if under corrected the insertion of a de-epithelialised flap or a small dermal graft and finally removal of the ectopic skin of the free flap replacing it with adjacent facial or neck skin. The timing of surgery is important and some advocate this being done early during growth others late to reduce the number of procedures during childhood. This depends on the severity of the deformity if mild it can be left until later particularly if it is only to correct chin and midline asymmetry. Severe hearing defects especially in bilateral cases should be corrected early with bone anchored hearing aids. Severe deformity will require interventional surgery on a number of occasions during childhood usually with distraction osteogenesis, costochondral grafts and osteotomy surgery with soft tissue and ear reconstruction.

### TREACHER COLLINS SYNDROME

Treacher Collins syndrome (mandibulofacial dysostosis) condition has been known since ancient times and has been well depicted in American pre-Columbian carvings and pottery (Box 33.5). It has an incidence of 1:50,000 live births and is an autosomal dominant condition (chromosome 5 within q31q35) with a variable degree of penetrance and expression and this can be compared with the incidence of facial microsomia which is almost twice as common 50% are spontaneous mutations. In Europe, it is known as the Franceschetti-Zwahlen-Klein syndrome. It is characterised

#### Box 33.5: Mandibulofacial dysostosis

- Also known as Treacher Collins syndrome
- Franceschetti-Zwahlen-Klein syndrome
- An autosomal dominant inherited condition with variable penetrance, sporadic mutations also occur—incidence 1:10,000
- Areas affected: Skull vault, malars, maxilla and nose with orbital and palatal clefts.

by clefting defects. Using the Tessier classification these are type 6, 7 and 8 and involve the orbit either at the infraorbital margin or at the lateral border of the orbit together with a cleft of the zygomatic arch. The clefting defects tend to be symmetrical and extend into the maxillae from the infraorbital area or from the frontozygomatic (FZ) suture down to the inferior orbital fissure. The mandible is always abnormal and is hypoplastic and joint development is poor. There is also sometimes an associated cleft palate. The clinical features are characteristic with an anti-mongoloid slant to the eyes (Figs 33.14A and B). The skull tends to be shorter anteriorly and often smaller than normal. The posterior cranial length may be increased. The orbits themselves are shallow. The malars are markedly hypoplastic and the overlying skin and soft tissues are reduced in volume and the nose appears to be more prominent in relation to the rest of the face. There is a hair bearing tongue, which extends onto the cheeks from the temporal area in 25% of cases. As far as the eyes are concerned, three-quarters of all cases have either true or pseudocolobomata affecting the lower eyelids and there is a lack of eyelashes (cilia) on the lower eyelids. Often, ophthalmic abnormalities occur extending into the globes. The ear pinnas are abnormal, often asymmetric and they tend to have a crumpled appearance and may be accompanied by ear tags. The external auditory meatus if present are rudimentary and are often stenosed leading to a severe conductive deafness as a result of developmental defects of

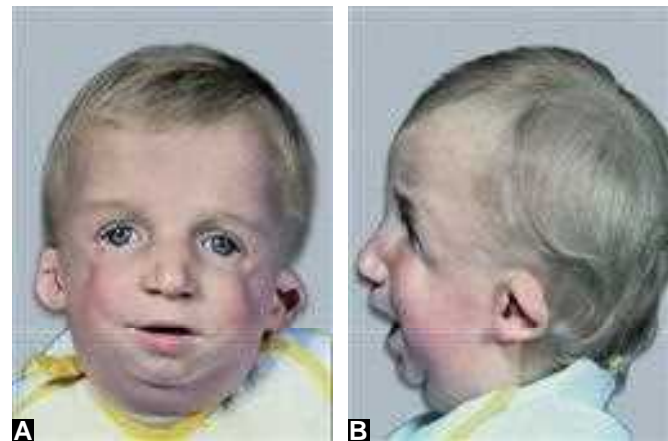


Fig 33.14A and B: Treacher Collins syndrome, clinical appearance

**Box 33.6:** Reconstruction—Treacher Collins syndrome

- Normal airway increase in "pharynx" as well project mandible and chin
- Reconstruct/derotate orbit and malar bones
- Normalise dental occlusion
- Reconstruction of ear
- Correct conductive hearing defect—implants

**Methods:**

- Orbital osteotomy
- Maxillomandibular osteotomies
- Genioplasty and orthodontics
- Ear reconstruction and implant prostheses
- Bone-anchored hearing aids
- Soft tissue surgery
- Distraction osteogenesis.

the ossicles. The mandible is bilaterally hypoplastic with shortening of the ascending rami and body as well as severe genial retrusion. The muscles of mastication are present and this results in a prominent antegonial notch and obtuse gonial angle. There tends to be some malpositioning of the muscles of mastication in the ramus area. The maxilla tends to have a high arch palate and may be cleft. Although it appears to be prominent, this is essentially in relation to the very small mandible and its antero-posterior position is usually acceptable. There are other defects that sometimes occur (Box 33.6). Most troublesome is post-nasal choanal atresia particularly in the infant where there may be severe symptoms of obstructive sleep apnoea. An early tracheostomy may be necessary especially in Nager syndrome which otherwise facially closely resembles Treacher Collins Syndrome. Usually, this is now improved by distraction osteogenesis of the angle region of the mandible (Figs 33.15A and B).

This will also bring the mandible forward to improve the occlusion of the teeth where there is often an anterior open bite (AOB). Advancement of the chin with a genioplasty is helpful also in repositioning the hyoid and it increases the size of the oro- and hypopharynx. Due to the severe hearing defect there tends to be a delay in speech development and a secondary effect on mental development if early correction of hearing is not undertaken. Usually, in the first instance this can be with simple conductive hearing aids with a band across the head but as soon as there is sufficient thickness of bone in the temporal bone, bone anchored hearing aids should be inserted.

This condition can be diagnosed prenatally especially when there is a family history so that at birth the airway can safely be maintained and if necessary an early tracheostomy can be undertaken. There also needs to be good support for the family. With modern surgery, a very good reconstruction of the defects can be anticipated but surgery needs to be carefully timed taking into account the necessity for correction of hearing and cleft palate at an early stage. A good ophthalmic assessment is also essential post-natally during the first few months. As soon as there is some growth of the mandible and when there are airway problems early distraction osteogenesis in the angle region of the mandible is required so that the tracheostomy may be closed at an early stage. Further lengthening of the mandible may be required from 5 years onwards. This would depend on the severity of the condition and this may be combined with reconstruction of the malar defects and bone grafting of those areas. Insertion of bone anchored hearing aids is also important and can usually be timed with other surgery. With repositioning



Fig. 33.15A—A. B. Frontal and lateral views of a child with Treacher Collins syndrome, showing the BAHA device.

of the mandible, orthodontic treatment is frequently required due to crowding of the arches and the steep mandibular plane angle to achieve a satisfactory occlusion with the maxillary teeth. Ear reconstruction may be timed with the move from primary to secondary school and similarly rhinoplasties. A few years after reconstruction of the malar defects it is often advantageous to osteotomise the reconstructed malars and to bring them into a more forward position to provide more normal cheek prominences for the face. Finally, towards the end of the growth period orthognathic surgery should be considered to correct discrepancies in jaw size and the dental occlusion. In some cases, the temporomandibular joints are grossly abnormal and the condyles are virtually absent and there is very poor growth in these areas and it is usually advantageous to reconstruct the condylar heads with a costochondral grafts on both sides and follow that a few years later with distraction of the mandible. However, there are some risks attached to advancement of the mandible and applying significant pressure in the temporomandibular joint area as this can lead to ankylosis of the temporomandibular joint with the consequent necessity later of further reconstruction in that area. The facies of Treacher Collins syndrome are very similar to that seen in Nager syndrome but that tends to be a more severe autosomal recessive condition. It is also associated with limb abnormalities. Very severe airway problems tend to occur and early tracheostomy followed by distraction of the mandible is essential. Both these conditions are best treated in specialised craniofacial units. It is also important to consider genetic counselling for the older child and family.

There are many other conditions associated with discrepancies in jaw size such as the Pierre Robin anomalad

and juvenile idiopathic arthritis (JIA) which result in severe under development of the mandible. As far as the Pierre Robin anomalad is concerned, this often appears severe at birth but this is often followed by quite rapid growth whereas in JIA this usually occurs at an older age and results in severe mandibular retrusion and airway problems. As a result of that there may also be ankylosis of the mandible which will require joint reconstruction.

It is also important to consider in trisomy 21 (Down syndrome), for the high grade patient, correction of the deformity. Although this is controversial tongue reduction followed by simple mandibular surgery and onlay grafts of the nose and reconstruction of the eyelids will render the patient more normal in appearance and as a result of that they are treated more normally and appear to be more intelligent. This should only be considered where the parents strongly request consideration and this should be done with a full psychological assessment and in the absence of any other significant life threatening pathology.

## INFECTION

### Acute Infections

Suppurating infections and large abscesses will spread into the spaces in and around the pharynx, maxilla and mandible these are almost always dental in origin and require to be treated urgently to prevent compromise of the airway or spread into the retropharyngeal and mediastinal areas. The essence of treatment is drainage of the infection and treatment with antibiotics (Figs 33.16A and B). When it is principally a cellulitis spreading across the floor of mouth this is extremely dangerous (Ludwig angina). This needs to



be treated aggressively with drainage from the submandibular areas and often intraorally to prevent further spread of infection. It is important to explore all the loculi and this is most easily done with a gloved finger through the incision into the cavity and drains need to be inserted and a careful watch on the airway during the immediate post-operative period is essential. A tracheostomy should be undertaken whenever there is doubt about compromise of the airway. Swelling in the post-operative period can be severe. Usually, a 5-day period of appropriate antibiotics is all that will be required after drainage. A microbiology report is essential as resistance to widely used antibiotics is common place. Details of the possible spread of infections into the parapharyngeal areas are illustrated (Box 33.7).

#### Box 33.7: Orofacial infection

- May be bacterial, viral, mycotic or parasitic
- Most serious acute infections around the jaws and face are odontogenic in origin
- May be localised or spreading. Treated by: (A) removal of the cause; tooth, (B) drainage of abscess, (C) prevention of spread and any necessary and (D) restoration of function
- If systemic side-effects treat with antibiotics, analgesia and rehydration may be required
- If there is trismus, dysphagia or dyspnoea surgical treatment under general anaesthesia is urgent
- Other specific infections—actinomycosis, tuberculosis, syphilis, protozoal infections may be complicated by HIV infection
- Spreading streptococcal cellulitis and staphylococcal infections require specific parenteral antibiotics and often fascial space surgical drainage
- Infections spreading into the mid-face may lead to cavernous sinus thrombosis and intracranial spread.

## Osteomyelitis

Types of osteomyelitis are shown in Box 33.8.

#### Box 33.8: Bone infections and related conditions

- Acute osteomyelitis
- Sub-acute osteomyelitis
- Chronic osteomyelitis
- Garrés osteomyelitis
- Chronic sclerosing osteomyelitis
- Osteoradionecrosis

Acute infections are rare in the neonatal period; these can result in osteomyelitis of the mandible or maxilla. In the case of the maxilla, it is almost always haematogenous in origin. In the mandible, especially around the temporomandibular joint, it may be due to ear infection or possibly a septicaemia and usually this would be either a streptococcal or staphylococcal infection. Failure to recognise and treat this with antibiotics early on can result in ankylosis of the temporomandibular joints and in the maxilla loss of teeth and bone from the area (Figs 33.17A to D). The child will present with a pyrexia,

cultures and monitoring with C-reactive protein (CRP) levels are helpful guides to the effect of intravenous antibiotic therapy. This can safely be started before culture results are available with intravenous penicillin and metronidazole. If there is pus or significant swelling, then urgent surgical intervention and drainage will be required.

Usually, in a child over 4–5 years of age sub-acute osteomyelitis will present following dental infection with swelling and pain over the mandible and breathing difficulties and with numbness of the lower lip when the body of the mandible is affected. This condition is rare in the maxilla but acute purulent infections are not uncommon and are usually dentally related and require drainage. More commonly, they present as a sub-acute bony infection in the body of the mandible as a result of dental sepsis and carious teeth especially in the malnourished child and there may be severe trismus, swelling, sinuses in the submandibular or cheek region (Figs 33.16A and B). Usually, there are mobile teeth present and there is expansion of the mandible. Radiographs will show a marked periosteal reaction with new bone formation, sequestra and radiolucencies in the body of the mandible. If present for a considerable time, a fracture of the mandible may occur and it can be the presenting feature. Almost always the organisms are oral organisms which respond to treatment with penicillin and metronidazole given intravenously in high doses. Surgical drainage will also need to be established with decortication especially when there are sequestra and sinuses present. Curettage and removal of the sequestra are essential as well as open drainage of the area. Where a fracture occurs and there is much loss of bone it is often helpful to put pins into the adjacent normal mandible on either side of the affected area to hold the mandibular fragments in the best possible position while healing occurs. A spontaneous fracture may also occur when treatment is undertaken with exploration of the affected area. It is important to preserve the inferior dental bundle and nerve to maintain sensation to the lower lip and chin. In tropical areas tuberculosis is common and may also be the cause of a more chronic osteomyelitis as may other infections local to the area, e.g. syphilis and HIV associated infections. These will need to be identified and treated accordingly. Care should be taken to avoid involvement of the temporomandibular joint if at all possible to prevent ankylosis. In the older child more chronic forms of osteomyelitis may occur and non-suppurative forms such as Garrés osteomyelitis occurs in children sometimes following dental extractions a possible initiating factor, with a proliferative osteitis. On radiographs punctate granulomata are frequently seen in the mandibular rami in association with a marked periostitis and loss of normal bony trabeculation. A local lymphadenitis is usually present. This would appear possibly due to an autoimmune process but that is not proven. Decortication of the affected



**Figs 33.17A to D:** Mandibular ankylosis right side from early acute middle ear infection

treatment. In the older child a similar chronic form occurs known as chronic sclerosing osteomyelitis again of unknown aetiology possibly dental. Steroids and decortication of the affected mandible may be helpful at the time of more acute exacerbations.

## TRAUMA

Paediatric fracture considerations are shown in Box 33.9.

### Box 33.9: Paediatric fracture considerations

- Bone healing and remodelling potential—good
- Shorter time to unite
- Treatment choices—ORIF—risks; intermaxillary fixation (IMF)—difficulties
- Jaw function modulates mandibular growth
- Generally, conservative treatment favoured
- Greenstick fractures—remodelling very effective
- Early treatment required to prevent malunion
- Dental factors—shape of teeth, resorption, position of permanent tooth buds
- Supplemental fixation, pyriform aperture, splinting and circumferential wiring
- Be circumspect with mini/micro-plateing

## Aetiology

Maxillofacial trauma is common in children, more so in boys than in girls. Most of the simple fractures seen are due to falls and bicycle injuries and tend to involve the primary dentition in the under 5 years of age group and the permanent dentition from 7 years onwards. More severe injuries tend to be related to road traffic accidents and these may be as a pedestrian or cyclist or with the unrestrained child in a car and also commonly with scooter and motor cycle passengers. As far as the latter are concerned, they are usually accompanied by friction burns and lacerations which may involve the eyes and ears and not infrequently there will be a skull fracture as well as fractures of the mid and lower face. In the very young child, the mid-face is very small and rarely injured and the mandible is also relatively small. As the child grows the mandible becomes increasingly fractured but it is not until the sinuses are significant in size that one sees fractures occurring more commonly in the mid-face. Most mid-face fractures are orbital and in the older age group, that is in the teens, when they become a prominent





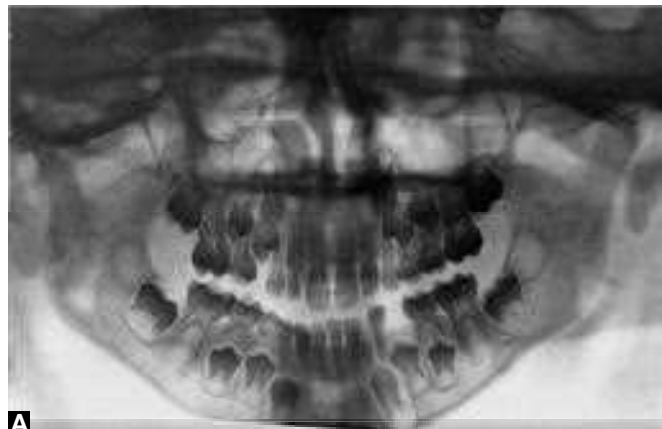
**Fig. 33.18:** Examination (with a good history)—gentle examination  $\pm$  restraint; look for signs, bruising, bleeding, occlusal changes and lacerations (chin). Avoid manipulation

the back seat of a car. There are distinct dangers from airbag damage when they are either restrained or unrestrained in the front seat. There may also be eye injuries as a result of this and the chemical substances in the airbag. Ideally no child under 12 years of age should be restrained in the front seat. As far as cycling is concerned, helmets do protect the skull and to some extent the face. The other sources of injury in the west are skate boarding and sports injuries. In most cases, these are relatively simple fractures and may be treated conservatively. Minor discrepancies are usually well corrected with healing in the younger child and it is often only in the teens that more complex forms of treatment are required in the form of plating and jaw fixation. Very often the teeth are loosened or fractured and every attempt should be made to retain teeth with appropriate dental treatment. If the teeth have been avulsed if reinserted within an hour they will usually be retained and eventually will become firm. They may require root treatment (Fig. 33.18). Perhaps most importantly in all cases of trauma, especially in young children, they require careful examination to exclude non-accidental injuries and where there is the least suspicion of non-accidental injury a full examination of the child must be undertaken looking specifically for other injuries. This has already been alluded to elsewhere and when a full paediatric assessment must be made.

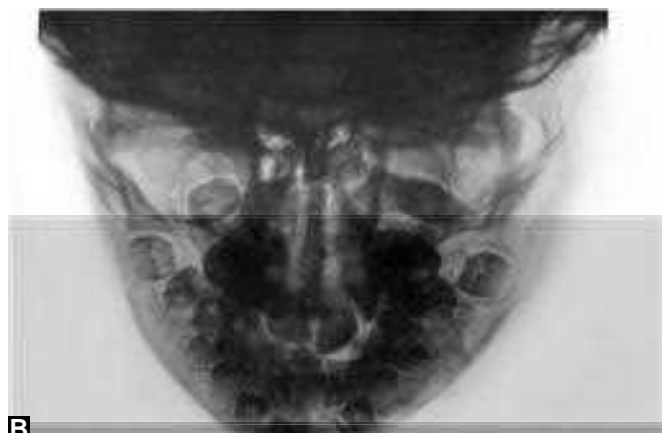
Facial bone fracture imaging is shown in Box 33.10.

**Box 33.10:** Facial bone imaging

- Conventional radiographs
- Orthopantomogram (Mandible/Maxilla)
- PA view (mandible)
- Intraorals (teeth) as required
- Mid-face—occipito-mental views 10°, 30° and CT scan (3D)



**A**



**B**



**C**

**Figs 33.19A to C:** Radiography: (A) Orthopantomogram—right condyle and left body fractures; (B) PA view—left mandibular condylar neck fracture; (C) CT scan—right condyle and condylar neck comminuted fractures

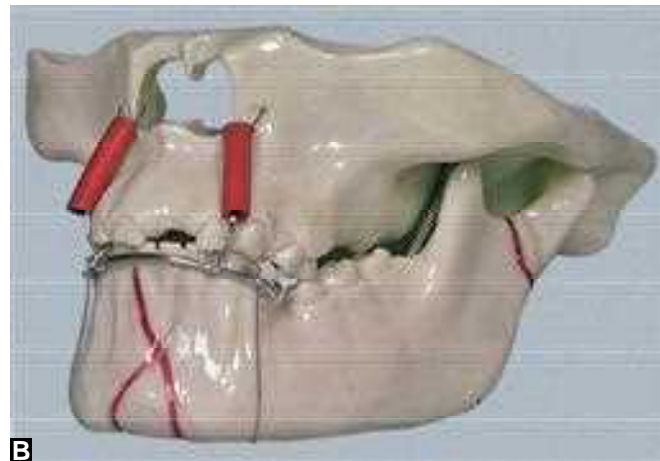
### Condylar Fractures

One area where there is some controversy over the management is that of fractures of the mandibular condyle or more commonly fractures of the condylar neck. Radiography is always required for suspected facial bone fractures, both

Most of these mandibular fractures, heal with very simple treatment if they are undisplaced and usually no fixation will be required and only maintenance of a soft diet and the avoidance of further trauma. Condylar fractures tend to be caused by falls and may be accompanied by a fracture in the symphyseal region of the mandible. Not uncommonly they are bilateral. Since the anterior fracture in the mandible is prominent and often pain is principally in that area it is easy to miss an associated condylar neck fracture. There is usually trismus and palpation of the condylar areas will tend to be painful. In the case of unilateral fractures, the mandible will tend to deviate towards the affected side. Lacerations and abrasions are often seen on the chin or adjacent to the chin area. The incidence of this type of mandibular fracture varies from 43% to 72% and tends to occur 2.5 times more commonly in males than in females in the 6–12 years of age group. Intracapsular fractures tend to occur in the younger age group notably under 7 years of age. They occur because the condyle itself is very soft and there is only a thin lining of cortical bone and it is very vascular. There is no neck to the condylar head and it appears to arise from the ramus itself. Therefore, it tends to shatter when traumatised. In the older child, most fractures are extracapsular and are of the condylar neck. In the older child, this tends to be lower in the neck where it is attached to the ramus. The condylar head has become much denser and the weakest part of the mandible is then the condylar neck. Some 58% of all fractures in the under 6 years of age will be intracapsular, whereas in the older child 78% are extracapsular at the condylar neck. The intracapsular fracture should be treated conservatively with gentle mobilisation, whereas the condylar neck fracture, if it is undisplaced, is treated with a soft diet and initially restriction of mouth opening. The consensus view for treatment of the condylar neck fractures in the under 10 years of age group is to treat them all conservatively. Even if they are slightly displaced the mandible itself regrows in that area and there is no long-term deformity present and the occlusion of teeth is maintained. An adaptive process of healing occurs in the condylar area. The problem with condylar head fractures in the younger age group is that they were more often missed and due to pain and discomfort the child does not open or move their jaws. They were given a semi fluid diet and no exercise. This can lead to ankylosis of the temporomandibular joint and it is primarily in this young age group that ankylosis occurs, especially in developing countries, where often treatment and recognition of the fracture does not occur until late on (Box 33.11).

#### Box 33.11: Condylar fracture

- Condylar head (< 6 years) comminuted—ankylosis risk
- Condylar neck fractures (> 6 years)—displacement and deformity occur with growth, deformity on the affected side of body comprises a bowed bone, shortening of ramus height and deviation of chin to affected side. On the unaffected side, the mandible appears



Figs 33.20A and B: Maxillomandibular fixation

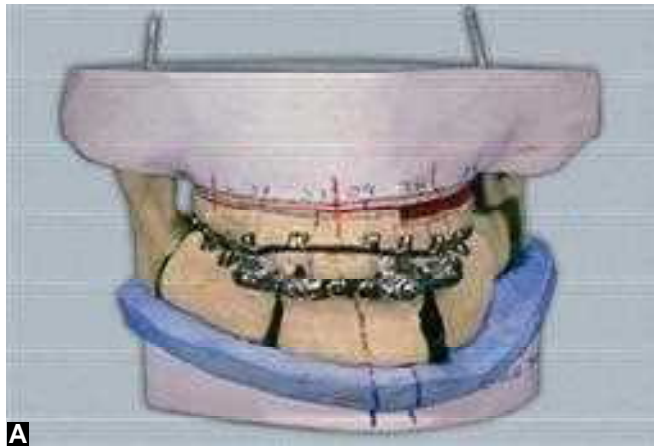
In the older age group, temporary immobilisation is sometimes required, especially when there is an undisplaced symphyseal fracture or a fracture in the anterior mandible. Arch bars or acrylic splints may be applied to the teeth to maintain the occlusion but open reduction and internal fixation (ORIF) has little place in the management of paediatric fractures and the consensus view now is that a closed functional treatment is the best (Figs 33.20A and B) (Box 33.12). Ankylosis leads to significant jaw deformity which requires complex osteotomy surgery for correction (Figs 33.21A and B).

#### Box 33.12: Maxillary-mandibular fixation

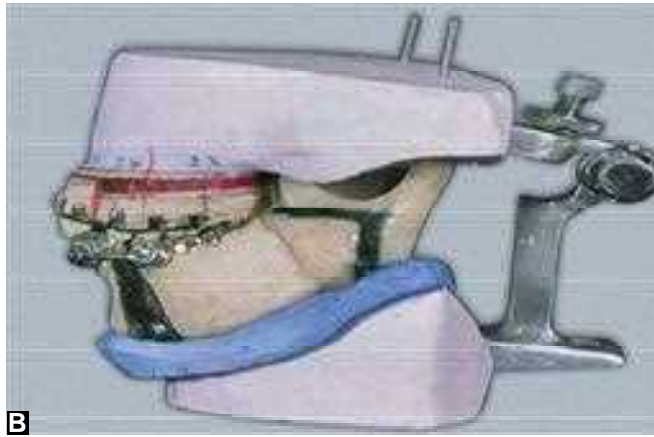
- At 2 years 20 teeth available for IMF
- Arch bar can be used with circum-mandibular support
- Before age of 2 and after age of 6 inadequate dental support therefore, use dental occlusal or orthodontic splinting
- Limited anatomical reduction often acceptable as remodelling will occur.

### Mandibular Fractures in General

Fractures in the over 10 years of age group may be treated



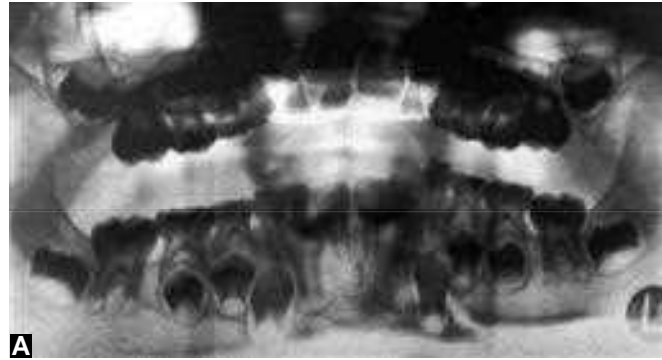
A



B

**Figs 33.21A and B:** Complex osteotomy model surgery for post-ankylotic deformity correction

this is the best approach. It should also be pointed out that any form of plating or fracture in the under 6 years old is fraught with danger in the body and symphyseal regions of the mandible because there are permanent tooth germs in the bone which may be damaged as they lie close to the lower border of the mandible. If there is displacement of a body fracture anteriorly, then small plates placed close to the lower border may be necessary preferably only into the outer bone plate. Often simple intermaxillary fixation (IMF) and an arch bar attached to the teeth is all that is required. If there is severe pain and multiple fractures, immobilisation of the jaws with IMF is often effective in relieving that pain. Compound fractures, i.e. all those that involve the teeth, require prophylactic antibiotic therapy for 3 days. Normally, penicillin or metronidazole is the most effective and least likely to cause complications. In the older child, the indications for ORIF (Figs 33.22A and B) tend to be failed conservative treatment, overriding of fragments with opening and closing of the jaws, severe loss of ramus height, displacement of the condyle into the middle cranial fossa



A



B

**Figs 33.22A and B:** Body fracture mandible. Internal fixation—advantages—open approach, sub-periosteal dissection, anatomic reduction and improved nutrition. No airway compromise. Increased of compliance

of that area. Compound fractures require copious irrigation and cleansing of the area. Removal of any non-viable bone may be undertaken although if clean as much as possible should be preserved. For multiple fractures, a simple splint over the teeth and placement of circumferential wires around the mandible to hold the splint in place and the fracture fragments is often the simplest effective treatment. Elastic IMF for traction may be applied between the mandible and maxilla if there is a significant malocclusion, especially straddle if there is an anterior open bite (AOB). Long-term follow-up is necessary to ensure growth occurs normally and the occlusion is maintained without the development of an AOB in bilateral fractures. It is also important to keep a watch on the teeth as damage to them, especially when they are displaced or depressed into the bone may result in failure of eruption and infection. It is also essential to identify fractured teeth which may initially not be obvious especially in the molar region but they are painful or rapidly become so. Consideration should be given also to the use of resorbable (polylactide plates) in children.

### Complications of Mandibular Fractures

The common fracture complications in the child are

the jaw and dysfunction sometimes related to a degeneration or severe damage to the condyles. There is a necessity to maintain good oral hygiene otherwise caries and periodontal disease lead on to dental infections. Where there is gross malunion and displacement of the mandible posteriorly there is a risk of impairment of the airway. Damage to the inferior dental nerves may occur and with an external approach there is a risk of damage to the facial nerve and persistent fistulae and occasionally Frey's syndrome (gustatory sweating). Severe injuries and post-traumatic stress syndrome may occur, especially when there is residual deformity which will require psychosocial support. It is important to take radiographs post-operatively to ensure reduction of the mandible has been effective and especially when closed management has been undertaken. The usual radiographs required pre- and post-operatively are an orthopantomogram (OPT) and a postero-anterior (PA) view of the mandible; occasionally coronal computed tomography (CT) scans for condylar fractures, and appropriate intraoral views of damaged teeth.

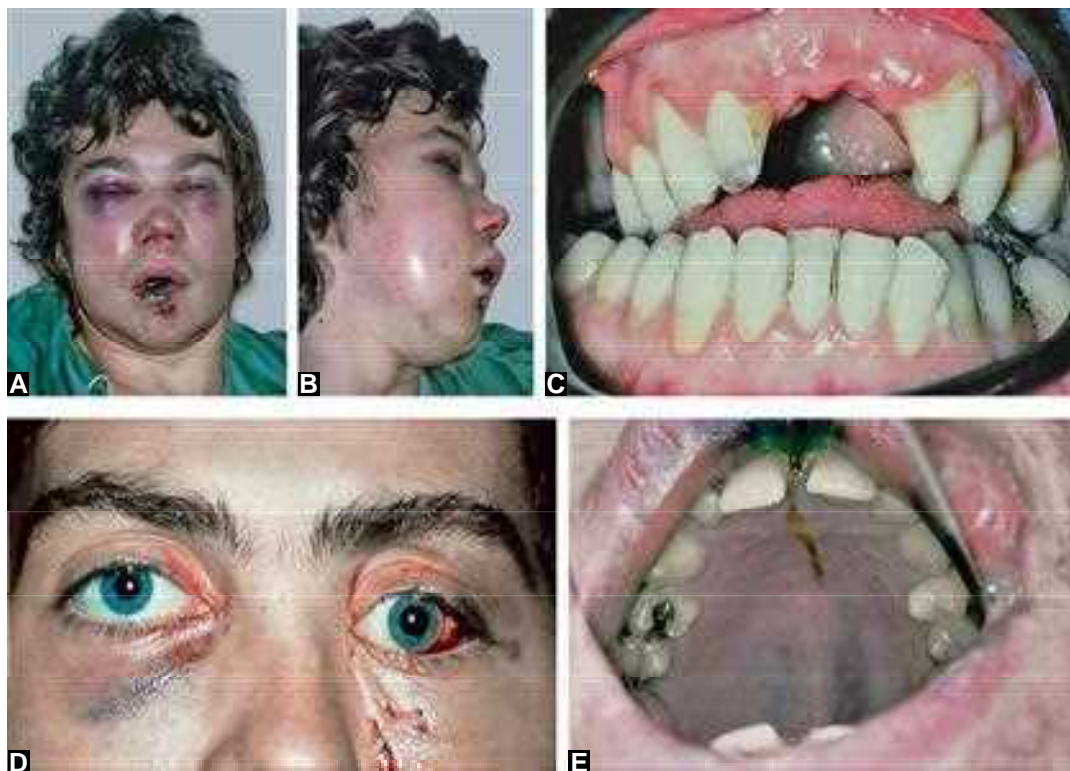
### Nasal Bone Fractures

The other fractures that sometimes cause significant problems are nasal bone fractures when they occur early in life. With simple breaks, there is no problem but when

there has been road traffic trauma and severe displacement of the nasoethmoid, this may cause significant deformity, especially when accompanied by craniofacial injuries. This is uncommon except in major high velocity injuries and occasionally in a sporting injury. As most of the nose is cartilaginous fractures are often difficult to diagnose and they are easily missed. Simple elevation of the nasal bones is usually all that is needed to avoid nasal obstruction and significant deformity. There may be overlying skin damage. Sometimes intranasal Gelfoam packing is helpful for a week. Follow-up should continue over at least 1 year. Only rarely is open reduction appropriate but septal straightening may be required. Care should be taken not to remove any bone fragments in that situation. Epistaxis may be treated with an intranasal pack and any septal haematomata should be evacuated. Infection rarely occurs. Occasionally, synechiae may require treatment. Diagnostically conventional radiographs are unhelpful but for the more severe injury CT scanning should be undertaken.

### Mid-face (Maxillary) Fractures

Mid-face and panfacial fractures are rare in young children due to the lack of sinus cavities and the smallness of the mid-face. They are in the older child (Figs 33.23A to E) (Box 33.13) usually associated with the orbits and nasoethmoidal



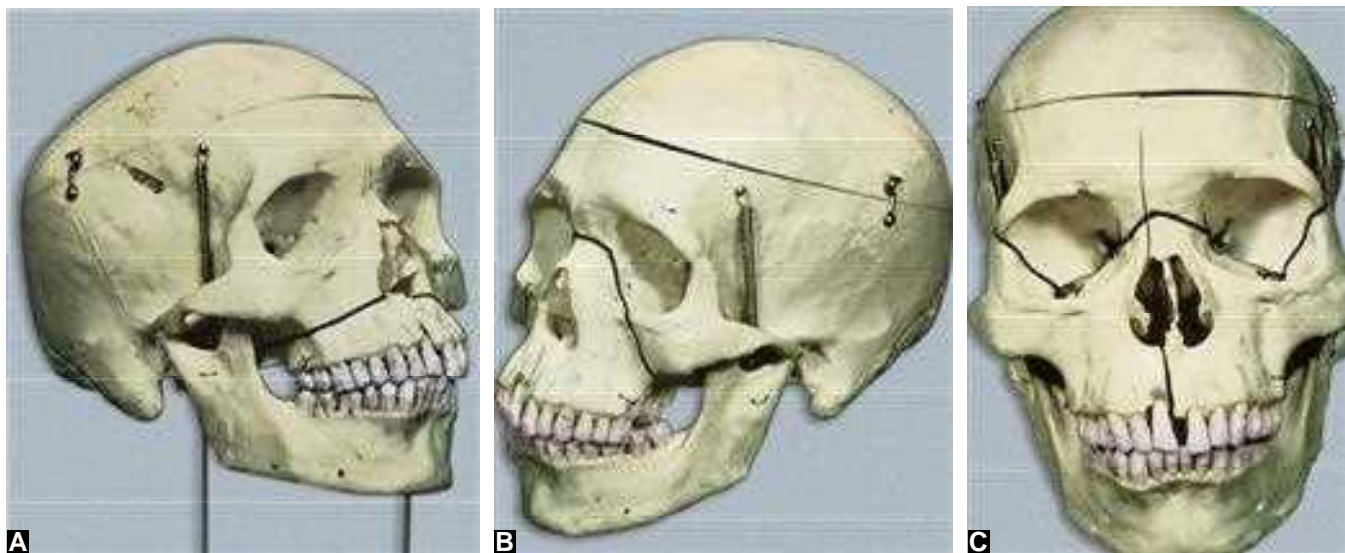
**Figs 33.23A to E:** (A and B) Clinical features— Le Fort III fractures with anterior open bite: (C) Anterior open bite: (D) Left orbital displacement

**Box 33.13:** Central middle-third clinical features

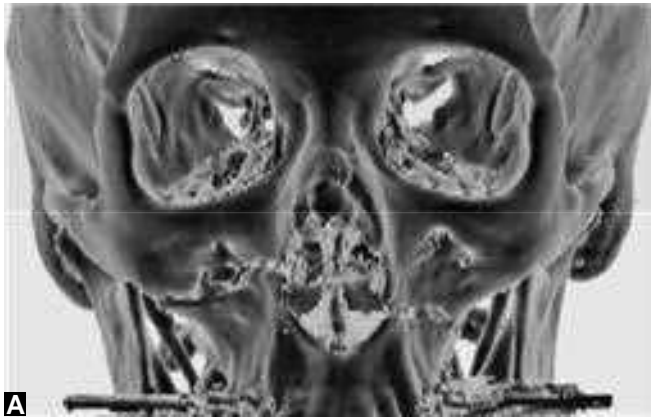
- Dish face deformity
- Bilateral periorbital haematoma
- Sub-conjunctival haemorrhage
- CSF rhinorrhoea
- Diplopia
- Infraorbital anaesthesia
- Anterior open bite (AOB)—retroposition of maxilla and trismus

complex and these need to be carefully assessed and reduced, avoiding generally open reduction of the nasoethmoidal complex. There may be airway problems and haemorrhage and there is commonly an associated head injury. Cervical spine injuries must be excluded. CT scanning is essential for diagnosis whereas conventional radiographs may be taken and used for the mandible and mid-face, CT scanning in the coronal and axial planes will give details of all the fractures present. It is normal to wait a few days, up to 7 days, before exploration of the fractures by which time most of the swelling should have settled. For Le Fort II and III fractures (Figs 33.24A to C), Cerebrospinal fluid (CSF) leaks need to be identified, must stop following fracture fixation, but prophylactic antibiotics are given to prevent meningitis. With severe craniofacial injuries, a coronal flap is required to expose the frontal region and to deal with any intracranial problems. This gives good exposure also to the lateral, superior and medial orbits and plate fixation is widely used and in young children usually micro- or mini-plates will be required (Figs 33.25A and B). As far as IMF is concerned, this should be avoided unless there are also fractures of the

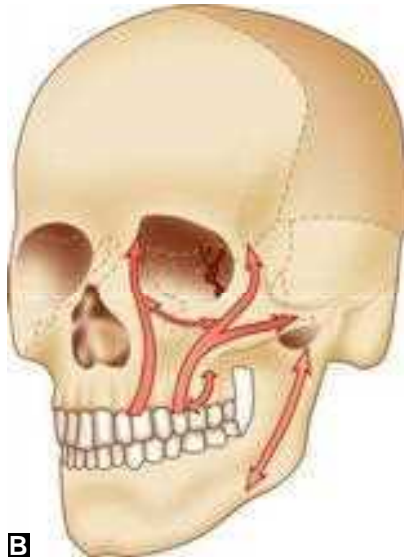
mandible in which case it may be necessary. Healing is very rapid with fractures involving the dentoalveolar complex and they may require a Le Fort I incision to expose the fracture sites in the buccal and labial sulci. It is important to retain the teeth and limit the periodontal damage as far as possible. Plating should be considered carefully to avoid damage to the roots of the teeth as well as any underlying unerupted teeth. It is important with high impact trauma when there are major facial injuries to assess the extent of the comminution and to suspend the soft tissues as there can be significant soft tissue damage in these cases. Otherwise, they tend to drag down the lateral canthi and the medial canthi may become detached and need repositioning with screws and micro-plates. As far as gun shot wounds in children are concerned, these are rare in the western world but they need to be treated with care, preserving all bone fragments, removing only foreign bodies and usually waiting before exploration for at least 48 hours for the swelling to settle. Any necrotic tissue will need to be identified and removed and frequently suction drainage will also be necessary. Where there is bone loss after limited debridement, the removal of dead tissue must be undertaken as far as possible, ideally with primary closure and with the later opportunity for secondary repair of any major defects in the oronasal cavities. With orofacial injuries, careful soft tissue repair is necessary with the preservation of all viable soft tissue. Where there is doubt about the vitality of tissue it is important that there is good drainage and the dead spaces are eliminated to prevent infection and antibiotic cover is given in that situation.



**Figs 33.24A to C:** Le Fort maxillary fracture lines (adult skulls)—vertical and horizontal mid-face fracture patterns: (A) Le Fort I (Guerin fracture)



A



B

**Figs 33.25A and B:** CT scan—Le Fort I fractures. Maxillary bony buttresses distribute forces through the facial skeleton and cranium and can be used for siting bone plates

### Zygomatico-Orbital Injuries

Zygomatico-orbital injuries (Box 33.14) are uncommon in young children (Fig. 33.26) but become increasingly frequent over the age of 12 to 13 years as the zygoma or malar bone is traumatised in sports injuries, road traffic accidents and assaults (Figs 33.27A to D). Clinically there will be loss of the cheek prominence, swelling, unilateral epistaxis, infraorbital anaesthesia (Figs 33.28A and B) usually a segmental subconjunctival haemorrhage, often diplopia, either proptosis initially sometimes followed by enophthalmos when the orbit is enlarged or orbital contents are lost out of the orbit in a blow-out fracture; less commonly with a blow in fracture the reverse occurs. Investigations undertaken include radiographs 10° and 30° occipito-mental views and CT Scanning ocular injury must be excluded with a check on acuity, field eye movements and fundi. Comminution and orbital floor blow-



**Fig. 33.26:** Very small maxillary sinus in a young child

outs can be identified on the CT and magnetic resonance imaging (MRI) scans. Treatment of the fractures usually at the FZ suture, zygomatic arch and infraorbital margin, is by reduction and fixation with titanium mini-plates. Blow-out defects can be covered with cranial bone graft or titanium mesh; post-operatively eye observations are essential to identify early retrobulbar haemorrhages (Figs 33.29A to C) (Box 33.15).

#### Box 33.14: Orbital and frontal fractures

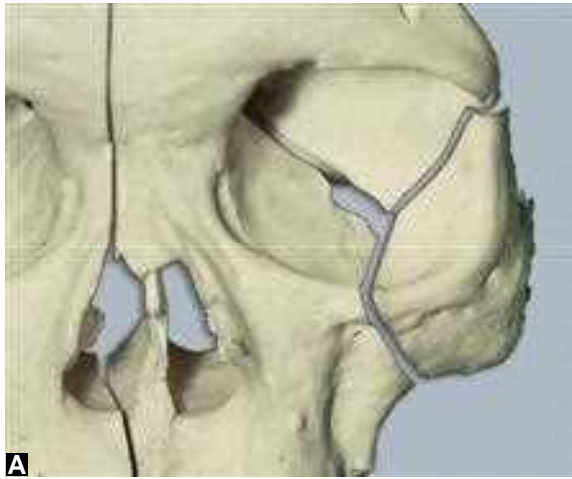
- After age 7 years, major growth of the sinuses occurs
- Orbital growth is then complete
- Traumatic floor and medial wall defects are not common

#### Box 33.15: Henderson's classification—malar fractures

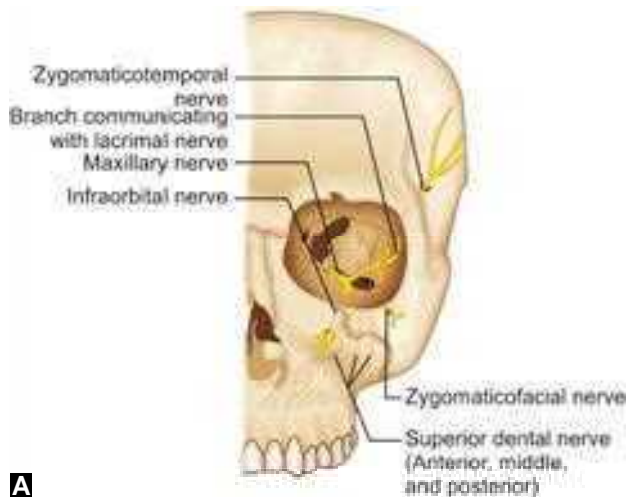
- Common fractures sites
- Type 1: Undisplaced
- Type 2: Arch fracture
- Type 3: Tripod fracture with intact frontozygomatic (FZ) suture
- Type 4: Tripod fracture with distraction FZ suture
- Type 5: Orbital floor blow-out with type 3, 4 or 7
- Type 6: Orbital rim fracture
- Type 7: Comminuted and complex fractures

### Soft Tissue Facial Injuries

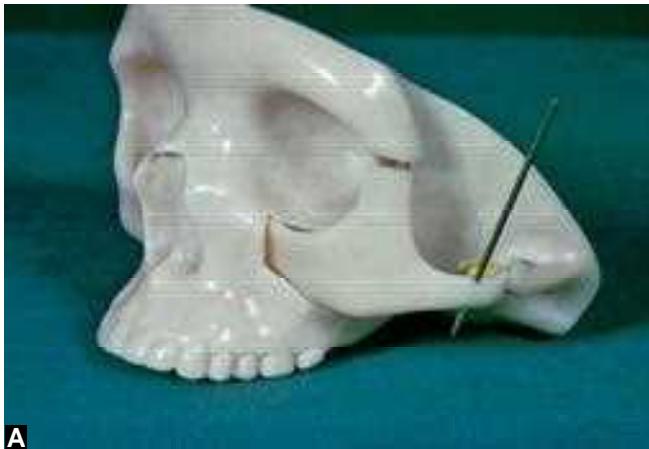
Soft tissue injuries, particularly dog bites, are not uncommon in children. Sixty per cent occurs in children under 15 years of age and in 84% the animal is well known to the child. These require careful debridement, preservation of tissue and suturing with antibiotic cover. Other injuries need to be excluded such as damage to nerves, blood vessels and ducts. A tetanus toxoid booster should be given unless they have been immunised for a shorter period than 5 years. In most cases, the severe soft tissue injury will be repaired under general anaesthesia. There should be an appropriately wide exploration of the wound. Management of lacerations in an excised wound requires an understanding of the relaxed skin



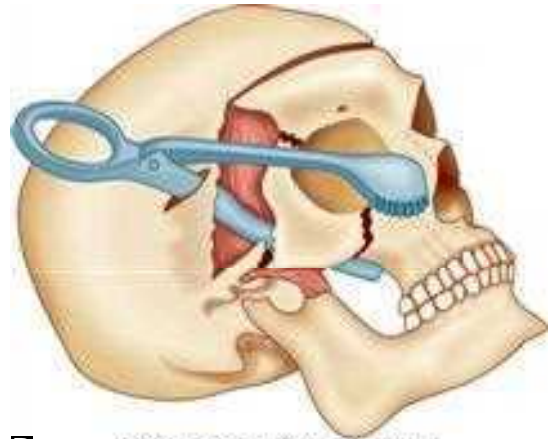
**Figs 33.27A to D:** Malar complex fractures right sub-conjunctival haemorrhage and left orbital floor blow-out fracture



**Figs 33.28A and B:** Sensory changes can affect the infraorbital, zygomatico-facial/temporal nerve branches

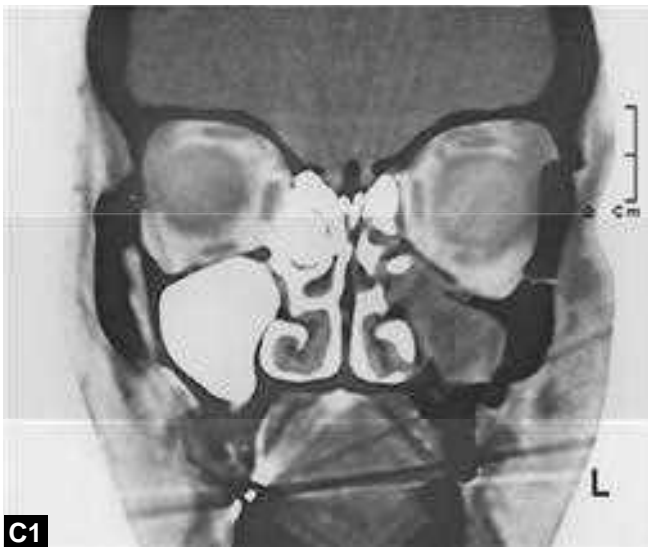


A



B

Malar elevation (Rowe's elevator)



C1



C2

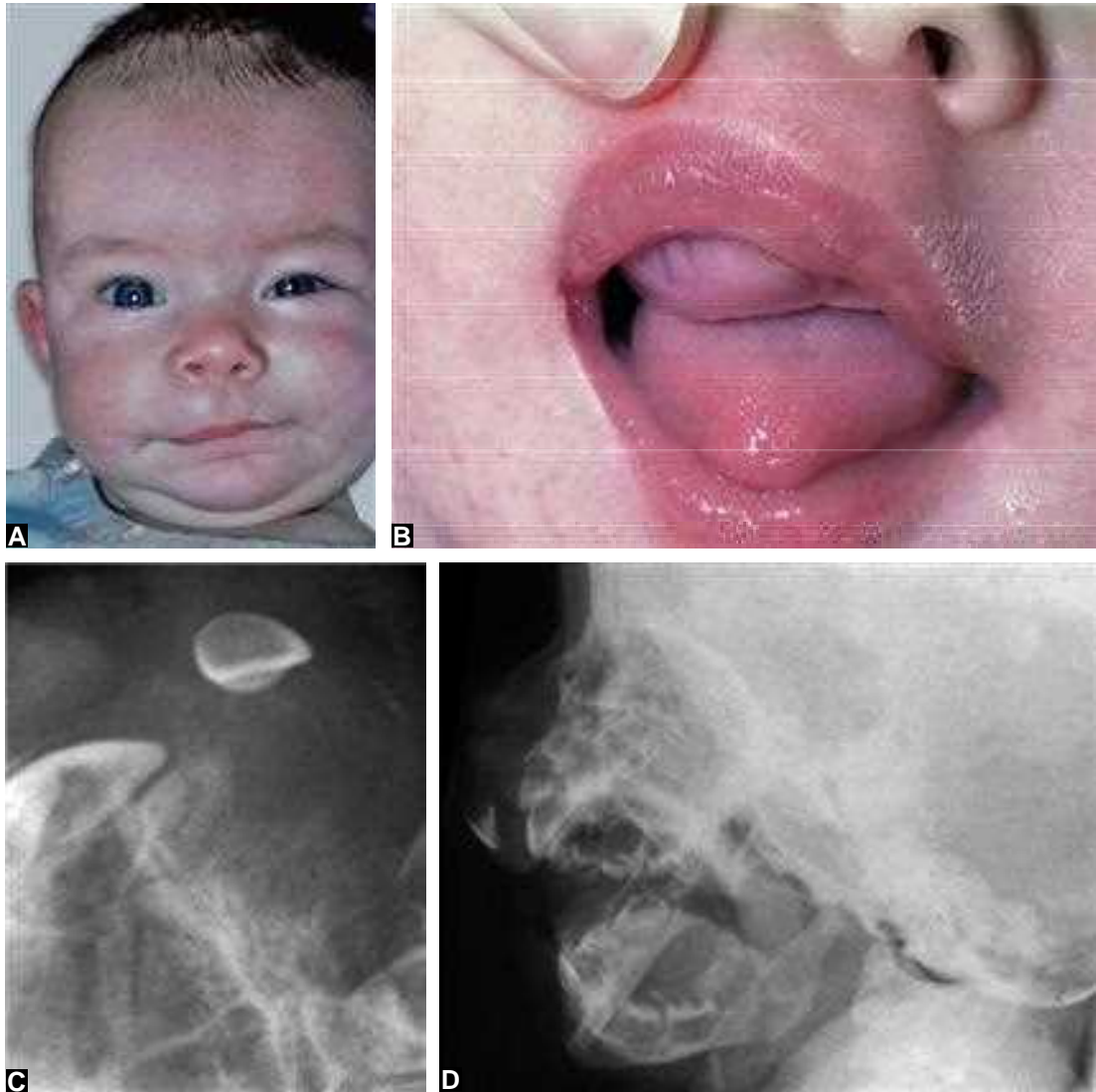
**Figs 33.29A to C:** (A) Common fractures sites; (B) Reduction of fractured malar; (C1 and C2) CT/MRI orbital blow-out fracture

tension lines of the face and using them to one's advantage. Scars along these lines have a better prognosis than when perpendicular to them. A ragged laceration along the skin tension line can be excised safely but if perpendicular to that minimal excision should take place. Primary closure should be undertaken within 24 hours. Animal bites tend to be potentially infected with polymicrobial bacteria. Human bites tend to have more anaerobic organisms and *Bacteroides*, *Staphylococcus aureus* and  $\alpha$ -haemolytic streptococci. These again require antibiotic prophylaxis. Careful washing of the tissues, no scrubbing but washing with betadine, and a thorough irrigation of the area is very important, with closure in layers. Sutures or cyanoacrylate should be used for skin closure. Sutures should be removed by 5 days and where necessary supported with steri-strips.

### PATHOLOGY OF THE JAWS AND ADJACENT STRUCTURES

Finally, there are a number of conditions related to the jaws which are pathological in nature which are developmentally related to the teeth and their supporting structures. Cysts are common in relation to teeth and these are frequently periapical cysts associated with dental infection. They may also be developmental such as keratocysts and dentigerous cysts which tend to surround the crowns of unerupted teeth. These erode the bone of the maxilla and mandible and may be quite large in size before they give any symptoms. Often only when they become infected they will start to leak into the oral cavity. Most of these are benign and adequate drainage and removal of the cystic lining of the dentigerous cyst will

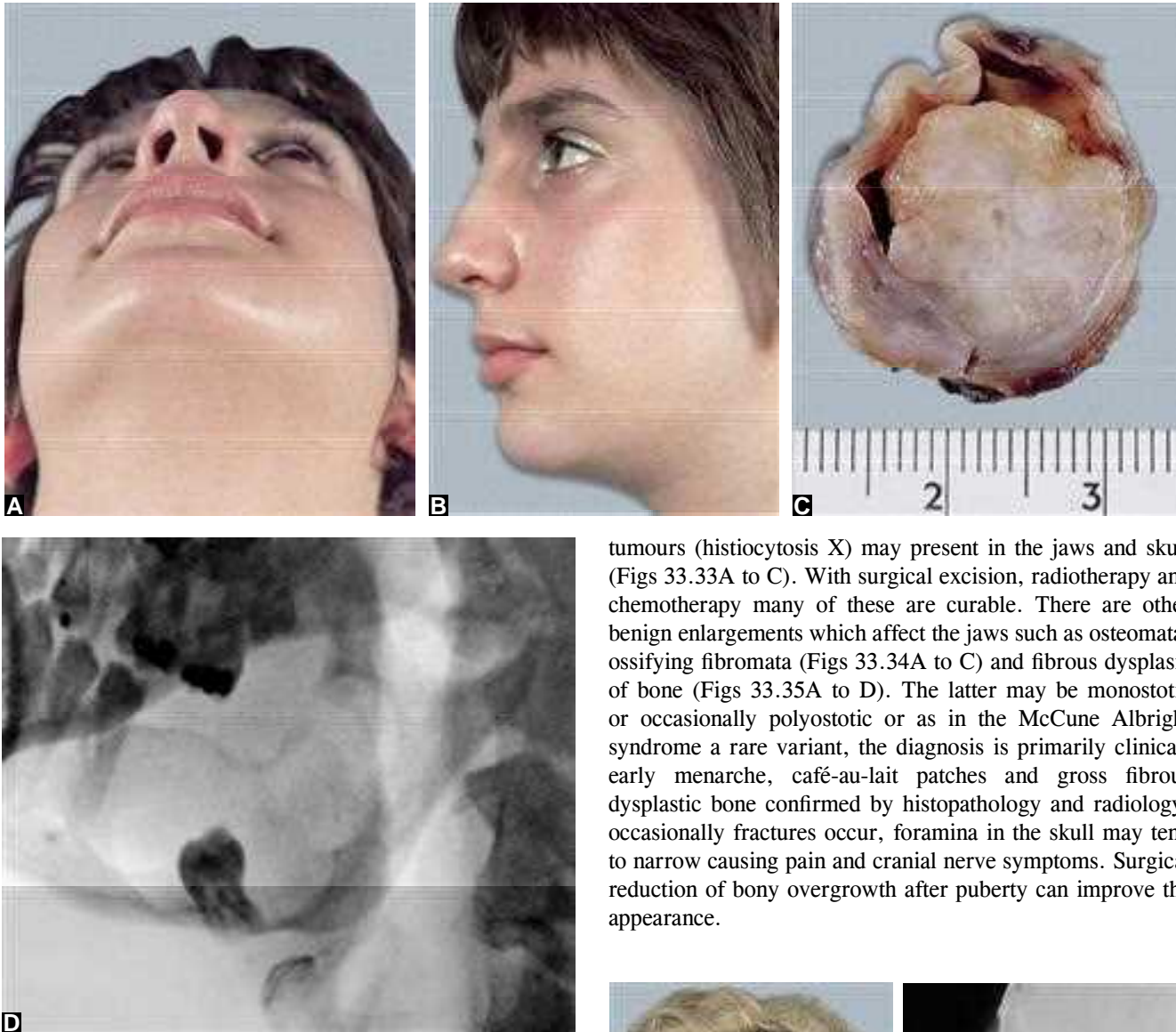




**Figs 33.30A to D:** Neuroectodermal tumour of infancy. Benign aggressive lesion in anterior maxilla at 6 months

allow that tooth to erupt into the oral cavity. Keratocysts are often found at the sites of teeth particularly in the ramus of the mandible. They tend to erode the inner portion of the mandible and require careful removal as they tend to recur. All tissue removed should be sent for histopathology. When keratocysts are multiple, they may be associated with the Gorlin-Goltz syndrome or basal cell naevus syndrome. At puberty they start to develop basal cell carcinomata particularly on the face and upper half of the body. These are normally rare at a young age group but by 25 years they are commonly seen in this condition. It is, therefore, important to recognise this syndrome in children early so that long-term follow-up may be carried out. Another syndrome that may present in children is Gardner's syndrome where there are multiple osteomata, often affecting the jaws and

teeth. There are often soft tissue lesions in the skin, e.g. fibromata, lipomata, and epithelial cysts but more seriously it is associated with polyposis coli with adenomatous polyps which eventually become malignant after puberty and a total colectomy is required. There are few rare tumours in early life affecting the jaws. In the midline of the anterior maxilla, the neuroectodermal tumour of infancy is occasionally seen during the first year of life as a bluish soft tumour displacing erupting teeth and here surgical excision is curative (Figs 33.30A to D). One serious and more common tumour is the ameloblastoma which arises from ameloblasts cells associated with the development of the enamel of the teeth (Figs 33.31A to D). These are locally invasive jaw tumours which may become quite large. They do not normally metastasise but are locally invasive and can



**Figs 33.31A to D:** Ameloblastoma arising from a dentigerous cyst

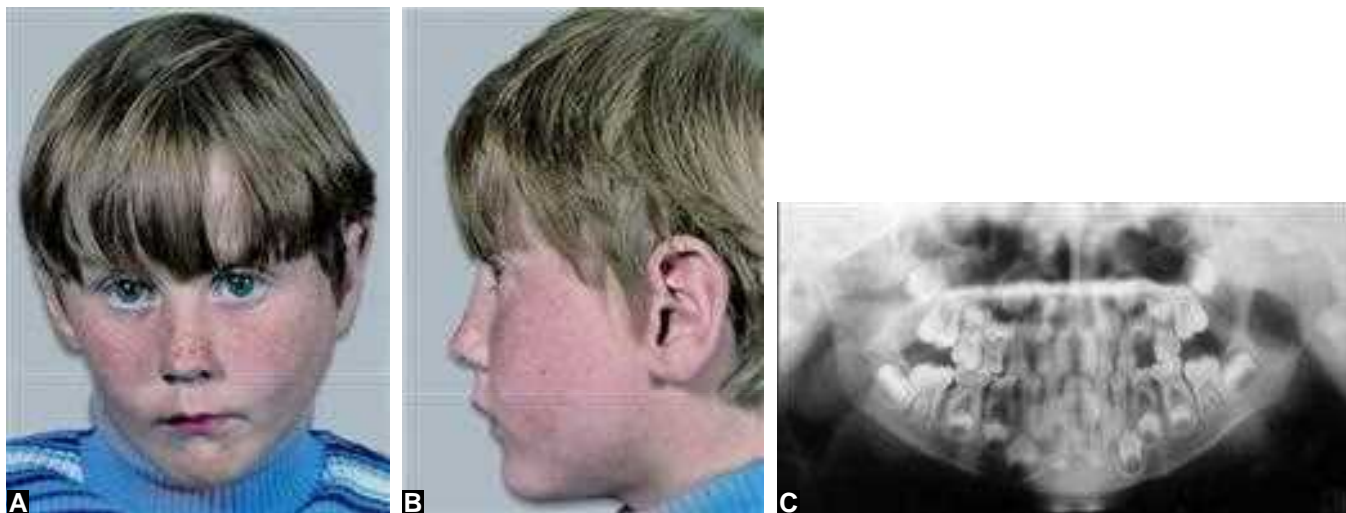
into the temporal region and medial to the mandible in the ramus area and can invade the middle cranial fossa. If they remain within bone they can be removed by a segmental excision, followed by bone grafting of the mandible. For the maxilla excision with at least 1 to 2 cm margin is essential as it is for the mandible. Ameloblastomata may arise in keratocysts and they may be associated with unerupted teeth treatment remains the same.

True malignancies of the jaws are rarely seen in children, for example osteosarcoma, chondrosarcoma, rhabdomyosarcoma and condylar synovial sarcoma. Occasionally, secondary tumours present in the jaws (Figs 33.32A and B). Langerhans

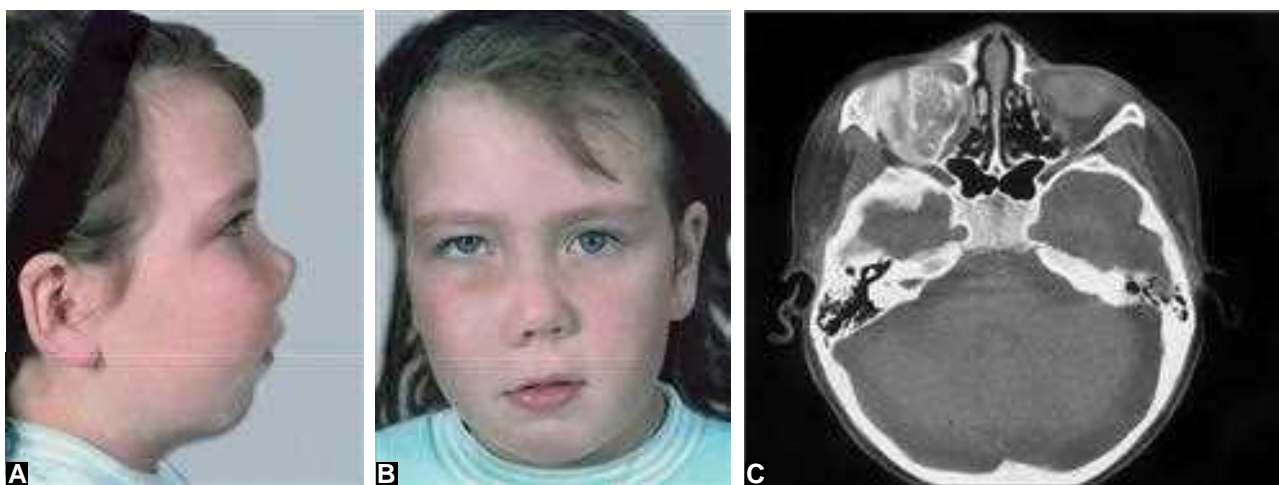
tumours (histiocytosis X) may present in the jaws and skull (Figs 33.33A to C). With surgical excision, radiotherapy and chemotherapy many of these are curable. There are other benign enlargements which affect the jaws such as osteomata, ossifying fibromata (Figs 33.34A to C) and fibrous dysplasia of bone (Figs 33.35A to D). The latter may be monostotic or occasionally polyostotic or as in the McCune Albright syndrome a rare variant, the diagnosis is primarily clinical, early menarche, café-au-lait patches and gross fibrous dysplastic bone confirmed by histopathology and radiology, occasionally fractures occur, foramina in the skull may tend to narrow causing pain and cranial nerve symptoms. Surgical reduction of bony overgrowth after puberty can improve the appearance.



**Figs 33.32A and B:** Secondary neuroblastoma mandible



**Figs 33.33A to C:** Hand-Schuller-Christian disease—lesion in left mandibular ramus (histiocytosis X)



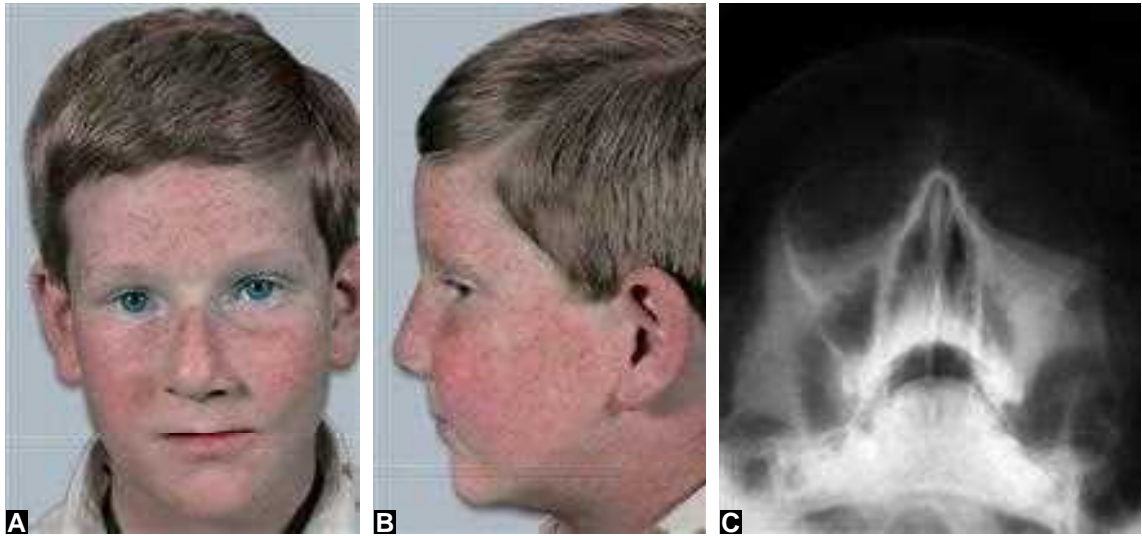
**Figs 33.34A to C:** Ossifying fibroma—rapidly growing benign neoplasm of the right mandible

Following resection for locally invasive lesions, reconstruction of the defect may either be by bone graft usually from the ileum or alternatively by the use of distraction. Sizeable bony defects may be closed in the mandible in this way. It is helpful to maintain the normal position of the fragments after resection has been undertaken so that the form/shape of the mandible may be maintained and this is most easily achieved with the use of pins into the adjacent normal bone prior to the resection or by reconstruction plates. There are other rare lesions of the jaws such as giant cell tumours, aneurysmal bone cysts and other growth abnormalities. The latter is seen occasionally with gigantism and acromegaly. From time to time, a meningocele and craniofacial clefting defects involve not only the naso-orbital area but also the mandible itself. Management of these conditions is largely in

the province of the neurosurgeon but reconstruction will be needed by the maxillofacial surgeon.

## VASCULAR ANOMALIES

They are common in children and frequently affect the face and oral cavity. They are dynamically classified into low-flow haemangiomas and high-flow arteriovenous malformations (AVMs) and there is an intermediate group. The difference between them is that haemangiomas histologically show an increase in endothelium and mast cells whereas malformations have normal endothelium and mast cells. In addition to that, there is a tumour group of haemangiopericytoma, chemodectoma, glomus tumours and angiosarcomata. AVMs include port-wine stain, Sturge-Weber, Beckwith-Wiedemann and Maffucci syndromes, a



**Figs 33.35A to D:** Fibrous dysplasia of left maxilla—continues to grow usually till growth has ceased



**Fig. 33.36:** Haemangioma of the left mandible

well as post-traumatic malformations. In infants the first sign may be a red mark on the face which develops into a strawberry naevus which grows rapidly, stabilises and in 70% involutes around 7 years of age leaving a small scarred area. Treatment is usually not required unless, for example it presents on an eyelid and interferes with vision or is on the lips/nose and ulcerates, bleeds, or becomes painful or infected, when treatment with cryo/laser therapy or excision can be helpful. Other rarer lesions are Kasabach-Merritt syndrome and haemangiomatosis which can be complicated by disseminated intravascular coagulation problems. The jaws (Fig. 33.36) are relatively rarely involved in AVMs. Investigation of these by CT scanning, angiography and MRI will identify high flow lesions these require embolisation of the affected vessels and surgical removal 48 hours later. A variety of agents are available for highly selective embolisation, e.g. gelatine sponge, collagen, alcohol, PV (polyvinyl) particles, coils and balloons. For other lesions, e.g. haemangiomas intralesional steroids, hot hypertonic saline, sclerotherapy, laser therapy and tattooing with titanium oxide are widely used.

## CONCLUSION

Paediatric maxillofacial surgery is an area of special interest which requires the close co-operation of several paediatric specialties, anaesthetists and a committed maxillofacial surgeon who frequently needs the help of the paediatrician and the skills of ophthalmic, neurosurgical and ENT colleagues.

# A Prescription for Play

## INTRODUCTION

Play! What a wonderful word—the very essence of childhood! For those whose family saw the importance of play, it calls up memories of our own childhood years when playing was the main focus of our waking hours. ‘Will you play with me?’ is one of the most expressive, expectant questions asked. The query carries with it a hope and anticipation about a time of fun and make-believe, a world of adventure and exploration, the world of the child. Play becomes an activity in which the child takes control, is motivated from within and uses his or her imagination. The absence of play is viewed as an obstacle to the development of healthy and creative individuals. For this reason, play is important for health care providers to consider and prescribe play as a vital intervention that facilitates healthy childhood development and learning.

## DEFINING PLAY

Play for children has been likened to work for an adult. It is what they do. Through play children learn about their world and the things in it.

Play also has been likened to a child’s rehearsal or practice for life since through play a child finds the root of future successes. During play children can switch roles, control situations and experiment with a variety of scenes where they can be the authors, stars and directors of their world. Research has shown that if children can play well, they will adjust well as adults.

The dynamic process of play develops and changes, becoming increasingly more varied and complex. Considered a key facilitator for learning and development across domains, play reflects the social and cultural contexts in which children live.

Play is a window to the child’s world and the adult who knows the value of play is committed to learning about children while they play. Play tells us much about children’s

lives, health and level of development. From observing their play we learn how children think, feel and believe. Play also can tell us of a child’s pain, conflict and insecurity. Those who value the personhood of children should also value the play of children.

## IMPORTANCE OF PLAY

Play allows children the chance to explore their environment, to learn how it works and how they relate to it. A child can express feelings and emotions through various types of play activities (games, art, stories, etc.) far earlier than they can express them in words. For older children, play may be the outlet through which they convey emotions that they are either unwilling to share verbally or do not have the sufficient vocabulary to express. Through play children can be anyone, at anyplace, at anytime.

Play is how children reconstruct their world in order to understand and master it. To be a child is to be little and powerless; someone big always has charge, telling you what to do.

In play children are autonomous; they are independent. They make the decisions, solve the problems and deal with the consequences. As Piaget<sup>1</sup> has said, autonomy should be the aim of education and to understand is to invent. In play, children are autonomous inventors.

## DESCRIPTION OF FORMS OF PLAY

Play takes many forms. Children play when they sing, dig in the mud, build a block tower or dress up. Play can be purely physical (running, climbing, ball throwing) or highly intellectual (solving an intricate puzzle, remembering the words of a song). Play also can be creative using crayons, clay and finger-paint. Play’s emotional form is expressed when children pretend to be mummies, daddies or babies. Skipping rope with a friend or sharing a book are examples of the social side of play.

## Sensorimotor Play (Baby and Toddler Play)

Even infants and toddlers enjoy play and develop through it. Babies spend lots of awake time exploring the world through play. To adults, it might look like the baby is 'just playing around.' In fact, the baby is learning many new skills. For a baby, play is the best time for learning.

In what Piaget<sup>2</sup> aptly described as sensorimotor practice play, infants and toddlers experiment with bodily sensation and motor movements, and with objects and people. By 6 months of age, infants have developed simple but consistent action schemes through trial and error and much practice. Infants use action schemes, such as pushing and grasping, to make interesting things happen. An infant will push a ball and make it roll to experience the sensation and pleasure of movement.

As children master new motor abilities, simple schemes are coordinated to create more complex play sequences. Older infants will push a ball, crawl after it and retrieve it. When infants of 9 months are given an array of objects, they apply the same limited actions to all objects and see how they react. By pushing various objects, an infant learns that a ball rolls away, mobile spins around and a rattle makes noise. At about 12 months, objects bring forth more specific and differentiated actions.

A toddler's second year brings a growing awareness of the functions of objects in the social world. The toddler puts a cup on a saucer and a spoon in his/her mouth. During the last half of this year, toddlers begin to represent their world symbolically as they transform and invent objects and roles. They may stir an imaginary drink and offer it to someone. Adults initiate and support such play. They may push a baby on a swing or cheer its first awkward steps. Children's responses regulate the adult's actions. If the swing is pushed too high, a child's cries will guide the adult towards a gentler approach. In interactions with adults such as peek-a-boo, children learn to take turns, act with others and engage others in play.

Toddlers play well on their own (solitary play) or with adults. They begin solitary pretend play around 1 year of age. During the toddler years, as they become more aware of one another, they begin to play side by side, without interacting (parallel play). They are aware of and pleased about other persons, but are not directly involved with them. During this second year, toddlers begin some form of coordinated play, doing something with another child. This form is similar to the preschooler's associative play.<sup>3</sup>

## Early Childhood (Pretend Play)

As children develop the ability to represent experience symbolically, pretend play becomes a prominent activity. In this complex type of play, children carry out action plans,

take on roles and transform objects as they express their ideas and feelings about the social world.

Action plans are blueprints for the ways in which actions and events are related and sequenced. Family-related themes in action plans are popular with young children, as are action plans for treating and healing, and for averting threats.

Roles are identities children assume in play. Some roles are functional, necessary for a certain theme. For example, taking a trip requires passengers and a driver. Family roles such as mother, father and baby are popular and are integrated into elaborate play with themes related to familiar home activities. Children also assume stereotyped character roles drawn from the larger culture, such as nurse, and fictional character roles drawn from books and television such as Spider Man. Play related to these roles tends to be more predictable and restricted than play related to direct experiences such as family life.

By the age of 4 or 5 years, children's ideas about the social world initiate most pretend play. While some pretend play is solitary or shared with adults, preschoolers' pretend play is often shared with peers in the school or neighbourhood. To implement and maintain pretend play episodes, a great deal of shared meaning must be negotiated among children. Play procedures may be talked about explicitly, or signalled subtly in role-appropriate action or dialogue. Players often make rule-like statements to guide behaviour ('You have to finish your dinner, baby'). Potential conflicts are negotiated. Though meanings in play often reflect real world behaviour, they also incorporate children's interpretations and wishes.

Preschoolers learn differently from school-age children. Play is essential to their early learning and is the main way by which children learn and develop ideas about the world. It helps them build the skills necessary for critical thinking and leadership. It is how they learn to solve problems and to feel good about their ability to learn.

Children learn the most from play when they have skilled teachers who are well trained in understanding how play contributes to learning. Most child development experts agree that play is an essential part of a high-quality early learning programme. Play is not a break from learning—it is the way young children learn.

The preschool years bring many changes for children in relation to social development. Children have more quality relationships outside the home and have a growing ability to play with other children. When children verbalise, plan and carry out play, cooperative play is established. This is the most common type of peer interaction during a child's preschool years.<sup>4</sup>

Construction play with symbolic themes is also popular with preschoolers, who use blocks and miniature cars and people to create model situations related to their experiences. Rough and tumble play with a lot of motion is

popular with preschoolers. In this play groups of children run, jump and wrestle. Action patterns call for these behaviours to be performed at a high activity level. Adults may worry that such play will become aggressive and they should probably monitor it. Children, who participate in this play become skilled in their movements, distinguish between real and pretend aggression and learn to regulate each other's activity.

### School-Age Play: Structured or Spontaneous

School-age children's playful activities can occur in two forms: (1) structured and (2) creative. Structured play tends to focus on a child's physical skill, natural talent or mental abilities to successfully engage in or with the game. Therefore, structured play is extremely beneficial to the physical, mental and social development of a child and should be encouraged and practiced. Such a plan enables a child to gain skills, knowledge and self-confidence.

Structured play includes sports, board games and simple fun events such as jump rope or marbles. Regardless of the game's complexity or intensity, set rules govern the proper way to play. A child's unique personality is confined within the boundary of the rules.

Most play is unstructured and happens naturally when opportunity for play arises. Such spontaneous play is the unplanned, self-selected activity in which children freely participate. Children's natural inclinations are towards play materials and experiences that are developmentally appropriate. Therefore, when children are allowed to make choices in a free play situation, children will choose activities that express their individual interests, needs and readiness levels.

Dramatic play or imaginative play is a common form of spontaneous play. Here children assume the roles of different characters, both animate and inanimate. Children identify themselves with another person or thing, playing out situations that interest or frighten them. Dramatic play reveals children's attitudes and concepts towards people and things in their environment. Much play of this sort addresses a child's sense of helplessness and inferiority. Through dramatic play, they are the big superhero, capable of any feat!

Creative play engages the imagination. Creative play is the natural childlike ability to express one's personality, feeling and attitudes with imaginative words and actions. This play focuses on having fun and sharing in a relationship by using the imagination. A child's ability to make-believe adventures, activities or events—not game rules—sets the limits of the game. Participants win by playing with imagination rather than by competing successfully against each other. A child's skill, strength, intelligence or age is of no consequence.

## PLAY: AN ESSENTIAL ELEMENT IN CHILD DEVELOPMENT

Practices and paradigms of what would be considered good child rearing and teaching have been debated, shifted, embraced and discarded over the years, yet basic concepts still remain. One of them is the child's intrinsic desire and tendency to play, which transcends age, time, culture, ethnicity, geography, socio-economic circumstances and abilities.<sup>5</sup> Acknowledging the child's inherent need to play, and that it effectively fulfils his desire to explore, learn and discover, is key to understanding that play is a building block as essential to healthy child development as are food and rest.

According to early childhood specialist, Eric Strickland 'Play involves the whole child. Play builds physical skills (such as balance, agility, strength and co-ordination), cognitive skills (including language, problem solving, strategising and concept development), social skills (sharing, turn-taking, cooperation and leadership) and the components for emotional well-being (joy, creativity, self-confidence and so on). It is the fundamental process underlying most of the learning children do before they come to school'.<sup>6</sup>

### Physical Development

Because play often involves physical activity it aids in the development and refinement of both gross and fine motor skills for children of all ages. This process can be observed as infants playfully begin to explore their world and are given room to roll, scoot and eventually crawl. Babies enjoy reaching for small objects like mobiles, streamers, rattles and small toys and as a consequence even begin to develop some of the finer motor skills like hand-eye co-ordination.

Throughout childhood, as children vigorously and joyfully use their bodies in physical exercise—running, jumping, skipping, climbing or throwing a ball, etc.—they are simultaneously releasing energy and developing muscles, balance and skills that will help them feel confident, secure and self-assured. As they gain increasing control over their bodies, and develop awareness of the space around them they learn to move safely and confidently in their environment.

In addition, during play children gradually become more adept at actions that involve different parts of the body. As they increase their skill at manipulating malleable materials and small items of equipment, they are also aiding the development of their small muscles. Fine motor control and hand-eye co-ordination are needed, for example, to build a tower of blocks, complete a jigsaw puzzle, draw a picture, manipulate play dough or interact with small toy figures. Large construction toys can help children's muscular development through any lifting, carrying, stretching or balancing they may do, and throwing and catching a ball will develop fine gross motor skills.<sup>7</sup>

No one is more convinced of the effects of play on learning and a child's physical development than education officials in Wales who introduced a play based curriculum for 3–7 years old in 40 schools throughout the country with physical activity as the foundational phase. According to Wales' officials, who see play as a vehicle for learning, the physical activity phase is of prime importance because it impacts all other areas of learning. For example, they consider activities like legos, painting and pegboard as prewriting experiences, since fine motor control is prerequisite to holding a pencil properly in order to make marks on a paper and later produce precise writing patterns, letters and number.<sup>8</sup>

Recent findings from research on the brain and learning have bolstered the importance of play as having a physical impact on children. It is well known that active brains make permanent neurological connections that are critical to learning, and inactive brains do not make the necessary permanent neurological connections. Research on the brain demonstrates that play is a scaffold for development, a vehicle for increasing neural structures, and means by which children practice skills they will need later in life. These findings raise the importance of play to a more serious exercise that has a powerful impact on physical as well as cognitive development.

### Cognitive Development

Have you ever watched children at play? If the answer is no, then try it some time. You will notice how totally absorbed they become in what they are doing, and their vivid imaginations and clever ideas will amaze you. They approach play with intense focus and inquiring minds.

No wonder then that practically all forms of play engage and enhance the development of cognitive related skills including imagination, creativity, problem solving, sorting and using information, and negotiation skills with peers. For example, block building, and sand and water play lay the foundation for logical mathematical thinking, scientific reasoning and cognitive problem solving.

Play fosters creativity and flexibility in thinking. Play has no right or wrong way to do things; a chair can be a car or a boat, a house or a bed. Pretend play fosters communication, developing conversational skills, turn-taking, perspective taking, and the skills of social problem solving or persuading, negotiating, compromising and co-operating. Pretend play requires complex communication skills; children must be able to communicate and understand the message, 'this is play.' As they develop skill in pretend play, they begin to converse on many levels at once, becoming actors, directors, narrators and audience, slipping in and out of multiple roles.<sup>9</sup>

We can see that play can have a beneficial effect on a child's development in the area of language. Through play children learn to ask questions or to develop an understanding

of a new set of rules in a game. For example, in the case of construction play when children are building something with others, they need to be able to form an understanding of instruction. The same can be said of board games, where the explanation and understanding of the rules or instructions can aid the development of language skills.

Finally, research indicates a strong relationship between play and cognitive development. In her extensive study on the effects of pretend play and cognitive development, Doris Bergen of Miami University concluded, 'There is a growing body of evidence supporting the many connections between cognitive competence and high-quality pretend play. If children lack opportunities to experience such play, their long-term capacities related to metacognition, problem solving and social cognition, as well as to academic areas such as literacy, mathematics and science, may be diminished. These complex and multidimensional skills involving many areas of the brain are most likely to thrive in an atmosphere rich in high-quality pretend play'.<sup>10,11</sup>

### Social and Emotional Development

The American Medical Association believes that the majority of a child's social skills come as a result of play since play enables children to interact and respond to others from an early age.<sup>12</sup> Children, like all human beings, have a basic need to belong to and feel part of a group and to learn to live and work in groups with different compositions and for different purposes. Play serves as a wonderful avenue for children to satisfy these needs and to develop social and emotional life skills. Children of all ages need to be socialised as contributing members of their respective cultures, and playing with others gives children the opportunity to match their behaviour with others and to take into account viewpoints that differ from their own.

Through play children can develop social skills, such as sharing with others, waiting their turn to do something, learning how to co-operate and how to lead and follow.

Children learn about themselves and others through play. By pretending, daydreaming, imitating others and having a good time, children learn to recognise their feelings and how to deal with them. In pretend play, children can be disobedient or uncooperative without getting in trouble. They can confront and overcome fears and, when under stress, play helps them forget their worries and gives them a chance to feel more in control of their world. At all levels of development, play enables children to feel comfortable and in control of their feelings by: (i) allowing the expression of unacceptable feelings in acceptable ways and (ii) providing the opportunity to work through conflicting feelings. In fact, children who play more seem to be happier and healthier.<sup>13</sup>

More than a respite from structured learning experiences, play is the cornerstone of learning and an integral link in



the chain of healthy child development. As Dana Johnson, leading child play therapist puts it, ‘Play fosters the growth of healthy children in every aspect of development—physically, cognitively, socially and emotionally. It really is food for children’s bodies, minds and spirits’.

## THE DANGERS OF PLAY DEPRIVATION

Sadly, in many parts of the World children are losing, and many have lost, the opportunity to engage in the crucial activity of play. Child soldiering, trafficking, exploitation, abuse and abandonment are just some of the reasons that children, even at an early age, are being stripped of the fundamental rights and necessities of a meaningful childhood. In the United States, and many other countries, the emphasis on academic achievement and testing, the predominance of computer and electronic games, and the increased incidence of highly scheduled children in extra-curricular activities have diminished the importance of, and time allotted for, adequate and purposeful play experiences both in the classroom and at home. The effects of this could be far reaching.

### No Time for Play

According to a study published by Dr Kenneth R Ginsberg and the American Academy of Paediatrics in 2006, a survey conducted by the National Association of Elementary School Principals in 1989 found that 96% of surveyed schools had at least one recess period. A decade later it was found that only 70% of even kindergarten classrooms had a recess period. In addition, since the introduction of the ‘No Child Left Behind Act’ of 2001, the amount of time committed to recess, the creative arts and even physical education has been reduced considerably.

‘This change may have implications on children’s ability to store new information’, stated Ginsberg, ‘because children’s cognitive capacity is enhanced by a clear cut and significant change in activity’. In addition, the reduced time for physical activity may also account for the present discordant academic abilities between girls and boys, since boys find it more difficult to navigate in that environment.

The Academy recognises that play is important for optimal child development. It further endorses the position that every child deserves the opportunity to develop their unique potential and urges all children to advocate to press for circumstances that allow each child to reap the advantages of play.<sup>14</sup>

The American Academy of Paediatrics has the following advice that can be applied worldwide:

- Promote free play as an essential part of childhood
- Emphasise the advantages of active play and discourage parents from the overuse of passive entertainment

- Emphasise that active child-centred play is a time-tested way of producing healthy, fit young bodies
- Emphasise the benefits of ‘true’ toys such as blocks and dolls, with which children use their imagination fully, over passive toys that require limited imagination
- Educate families regarding the protective assets and increased resiliency developed through free play and some unscheduled time
- Reinforce that parents who share unscheduled spontaneous time with their children and who play with their children are being wonderfully supportive, nurturing and productive
- Support parents to organise playgroups beginning at an early preschool age
- Support children having an academic schedule that is appropriately challenging and extra-curricular exposures that offer appropriate balance.

## ADVICE FOR PARENTS (OR CAREGIVERS)

- *Allow for exploration:* Children play using their entire bodies and all of their senses. Let them see, hear, touch, smell and feel things to try them out. This means lots of supervision and regular checks to make sure they are exploring safely.
- *Watch your child play:* Be prepared for surprises! While watching your child play, you learn a lot about their interests, attention span and skills. Your observations tell you how to play with your children and when to offer new playthings as they grow. You’ll also find the best time to join in.
- *Accept invitations to play:* Young children usually spend most of their time with parents and caregivers. Children may include you in their play naturally. Be ready to join in, but avoid taking over. Remember that children learn and enjoy more when they stay in charge of their own play. When adults respect children as they play with them, children play longer. This increases their attention span. Children learn more and show more advanced play when they have chances to play with adults.
- *Provide play space:* Small children need room to play. If your home or yard is unsafe or too small, find a park to play in several times a week. At home, teach your child the house rules and allow him to play in spaces where he can jump, climb, crawl and creep safely.
- *Provide playtime:* Young children play all the time. Routines like bathing, eating and dressing can be just as much fun and adventurous as trips to the park. Allowing a little extra time for everyone to have fun during these routines helps children develop a sense of time management and responsibility. This can help them now with their play skills and later in school and at work.

- *Provide play materials:* Children can create their own fun with crumpled paper, pots and pans, large cardboard boxes, play dough, paper, crayons and bubbles. Arrange a place for playthings where children can select them. A shelf is better than a clothes basket so children don't have to search for playthings. It also makes it easier for them to learn clean-up skills. When children lose interest in certain toys and other play materials, put those objects out of sight. Bring them back out a few weeks or months later. You may notice the children now use the toys differently because they have learned new skills.
- *Encourage different types of play:* Young children learn from many kinds of play. Encourage both quiet and active play. Encourage your children to play outdoors as well as indoors. Find ways to let them use their big muscles (legs, arms) and small muscles (fingers, toes). Let your children practice and repeat activities. Use words to explain what is happening when they play.

Through creative play, health providers and parents are given the unique opportunity to speak to a child in the language he or she understands and loves. Speaking in their language results in strong bonding and building of relationships.

## PLAY'S ROLE IN EMOTIONAL HEALTH

We have had an in-depth look at play's role in contributing to children's healthy growth and development. It has been well documented that therapies using play also have a vital role in children's recovery from the deep emotional pain they suffer from traumatic situations encountered in their homes or communities. Medical providers often witness firsthand the consequences of children's traumatic experiences when they are brought in for treatment after witnessing or having been a victim of a traumatic event.

Children's trauma symptoms are often compounded from a variety of abuses stemming from experiences such as becoming orphaned through their parents' deaths, being abandoned to live on danger-filled city streets, forced to participate in girl child practices, working in dangerous child labour situations, being sexually exploited, witnessing acts of domestic or community violence, or being involved in war or natural disasters. The resulting fear or terror resulting from such traumas is so overwhelming that it impacts the child's thoughts, feelings, behaviour and even body functions. Trauma greatly affects the emotional health of every child.

The fundamental basis of successful emotional healing in these children is directed towards one basic principle—restorative intervention should begin where the child is emotionally, cognitively and spiritually traumatised. To obtain this information about a child, it is critically important to have knowledge of healthy childhood development and to remain aware that play is the primary form of communication

for all children. For a child to be restored to emotional health, they need to communicate their trauma stories and their feelings surrounding the event. Play is a major key in facilitating a child's communication.

## EMOTIONAL ISSUES STEMMING FROM TRAUMA

Trauma-produced emotional problems, along with the resulting losses and stress, lead to behavioural and emotional issues including psychosomatic illnesses such as headaches or stomach aches. Often the physical symptoms are the body's last attempt to communicate when all other channels of communication are blocked. The children are attempting to convey their need of someone to understand that they are hurting, sad or afraid. Children have a tolerance level for just how much sadness they can deal with before the body reacts. Because emotional symptoms can cause real pain within children, they often are misdiagnosed as having a physical illness. Emotional pain, however, won't go away just by giving a child medicine.

Normally, children who experience or witness extreme threat or trauma respond with symptoms that fit into four general categories:

1. Having strong memories that repeatedly intrude on their normal functioning.
2. Engaging in endlessly repeated behaviours.
3. Developing trauma-specific fears.
4. Changing their attitudes about friends, family, life in general and the future.

Children who have trauma-related symptoms need opportunities to express their feelings of anger, fear and sadness. Often, however, children do not have the words to relate what has happened or to express how they feel about what they experienced. One prevalent trauma that is difficult for a child to verbalise is sexual abuse. In this kind of situation play activities can become a direct substitute for words, giving children the opportunity to search for and experiment with alternative solutions for resolving their emotional pain.

## DEFINING ORGANISED PLAY ACTIVITIES (PLAY THERAPY)

Organised play for emotional healing entails purposeful, guided play (not random play on a playground) that involves keen observation of what is being acted out and a sensitive interpretation. Although play therapy requires professional training, special training is not necessary to assist a child in a play situation if the adult has an open respect for children and their play does what seems or feels helpful for the child. As in observing emotionally healthy children, much can be learned by watching a child at play, looking at his drawings or watching a child-produced drama.

## PLAY: A MEDIUM OF COMMUNICATION

Children who have experienced deep trauma must be able to talk about their feelings before healing can occur. Talking is the starting point of a child's healing process. Children's ability to talk about the trauma implies that a trusting relationship has been established. If children do not express their feelings of insecurity, anxiety, fear, terror, distrust and sadness, they may bury these feelings deep inside, preventing their emotional healing. Children who have the opportunity to express their feelings become stronger and more resilient, feeling more secure, valued, loved and loving.

'Talking' does not just occur when a child uses words! Talking with children may be through words or through play activities. Play activities are a natural medium for self-expression, facilitating a child's communication. Play, being the developmental language of a child, provides children whose traumas have overwhelmed their emotions and ability to cope to have a medium for communication and expression of their feelings. For children whose trauma has left them stuck in a level of development, guided play can enable them to move on to the next crucial stage in the cycle of their development. Also since play is a normal part of a child's life and development, children who engage in play therapy are able to deal with the emotions that are experienced after the traumatic event in a way that is developmentally appropriate for them.

## METHODS OF PLAY THERAPY

All children have different needs and different ways of expressing those needs. To accommodate these differences, a variety of play activities can be utilised as a means of communication and expression of thoughts and feelings. Some activities, such as a playroom, can facilitate one-on-one or group sharing. Often a group of children are involved in an activity such as drawing pictures that depicts the traumatic event and provides clues on how the children feels about what happened.

The method utilised is determined by culture, the enormity of the crisis (such as a natural disaster that affected a whole village), the type of activity planned or a child's preference. For all methods children are invited to express their feelings through an assortment of art media: role play, drama, drawing, music, sand tray, storytelling, etc. Having an equipped play room or use of games and sports are also effective forms of play. The following describes two commonly used activities.

### Playroom

A playroom is a room or area that has been especially designed and furnished. Children can use toys and equipment as tools to

express their emotions and to engage in drama, art (drawing, painting or colouring) or other forms of expression such as dancing or singing. In the playroom, toys are viewed as the child's words and play as the child's language - a language of activity. Therefore, a careful selection of play materials that allow children to express themselves is a priority. Emotionally significant experiences can be expressed more comfortably and safely through the symbolic representation the toys provide.

The use of toys enables children to transfer anxieties, fears, fantasies and guilt to objects rather than people. In the process children are safe from their own feelings and reactions because play enables them to distance themselves from traumatic events and experiences. There they do not become overwhelmed by their own actions because the act takes place in fantasy. By symbolically acting out a frightening or traumatic experience or situation through play, and perhaps changing or reversing the outcome in the play activity, children move towards an inner resolution. They then are better able to cope with or adjust to problems.

### Art

Art is a wonderful medium for children to express feelings and thoughts too difficult to talk about. Since creating is a less direct means of expression, it provides a way for children to communicate confusing or hurtful thoughts through imagination rather than words. Drawing pictures depicting their trauma produced feelings of fear, anger and anxiety not only helps children identify these feelings but also can lead to the development of healthy coping skills. The goal of art activities is for children to better understand themselves through self-exploration and a shared interpretation of their own art.

## BENEFITS OF ORGANISED PLAY

Children need time to open up and share their pain. They also need a trusted person who will listen. Play provides for both of these needs. A bond of trust between a caregiver and a child can be developed through interest and involvement in a child's play at his or her level. Once the child has established a safe relationship with the caregiver, the child will begin to go directly to his or her area of pain and concern through play. Therefore, play can be used to help a child 'talk' about the traumatic experiences with someone they trust.

'Talking' helps children process their trauma produced feelings and re-enter their developmental cycles that were interrupted by what they experienced. The sooner a child can appropriate the healing effects of a play environment the sooner hope re-enters the child's world of experience. Play activities are the main restorative approach for children experiencing trauma. Research has shown that if children can play well, they will adjust well as adults.



Fig. 34.1



Fig. 34.2



Fig. 34.3



Fig. 34.4



Fig. 34.5



Fig. 34.6



Fig. 34.7



Fig. 34.8



Fig. 34.9



Fig. 34.10



Fig. 34.11



Fig. 34.12

Figs 34.1 to 34.12: Games children play for fun and enjoyment

Such activities enable children to express what is going on inside of them: their fears and anxieties, anger, hurts and feelings about the traumatic event that has occurred. Play activities also allow children to work through the grief process with a trusted adult.

### Play Activities: A Restorative Approach

Realising how important play is for the development of the child, we must also recognise the need for providing traumatised children with a safe place to play, an opportunity to play and suitable materials for play—those that will stimulate fun and creativity for the child.

Play activities are the main restorative approach for children experiencing trauma because they:

- are a natural medium for self-expression, facilitating a child's communication;
- allow for a healing release of feelings;
- can be renewing and constructive; and
- allow the adult a window to observe the child.

A child-centred play activity also is one of the most powerful ways to help children recapture what was taken away from them during the trauma. The losses include a sense of:

- Control (in play they are given choices)
- Power (they can choose the story line)
- Safety (they are gaining control of their situation)
- Trust in adults (when adults honour and value children's play, the children are empowered to open up and share)
- Hope (play can create, re-enact and recreate situations in a way that helps children know things can be different, giving them hope for the future).

In summary, play gives children the opportunity to share their stories through their natural means of communication. Play also is a child's natural method of learning, developing and expressing their feelings. Play becomes a window both to look into and to observe what is going on inside the child. Given the opportunity, children will play out their feelings

and needs in a manner or process of expression similar to adults. Although the dynamics and means of communication are different for children, the expressions (fear, anger, happiness, frustration) are comparable to adults. However, unlike adult therapy that is based on cognitive knowledge, children's play activities trade experiences for learned knowledge. Figures 34.1 to 34.12 show games that children play for fun and enjoyment.

### REFERENCES

1. Gordon, Ann Miles, Kathryn, et al. *Beginning and Beyond: Foundations in Early Childhood Education*. NY and Canada: Delmar Publishers; 1989;p.32.
2. Piaget, J. *Play, Dreams and Imitation in Childhood*. New York: Norton.
3. Available from [www.kidsource.com/nature of child's play](http://www.kidsource.com/nature_of_child's_play).
4. Gordon AM, Browne KW. *Beginnings and Beyond: Foundations in Early Childhood Education*. California: Delmar Publishers; 1989;p.324.
5. *Playing for keeps*. Available from [playingforkeeps.org](http://playingforkeeps.org) [Accessed 2005].
6. Strickland, Eric. *Power of Play*. *Early Childhood Today*. 2000.
7. Rise, Gabriel. *Play and Child Development*. 2006. *Ezine @ articles*.
8. *Teacher's TV. Learning Through Play*.
9. *Lessons in Learning; Canadian Counsel on Learning early Childhood Research and Practice*. 2006.
10. Bergen, Doris. *The Role of Pretend Play in Children's Cognitive Development*. *Early Childhood Research and Practice*, volume 4. 2002.
11. American Medical Association. Available from [www.medem.com](http://www.medem.com)
12. *Children at Play*. The Creativity Institute. Available from [www.creativityinstitute.com](http://www.creativityinstitute.com)
13. Johnson, Dana. *When is Play Not Playing*. *Natural Family Online*. 2007.
14. Ginsberg, Kenneth R. *The importance of play in promoting healthy child development and maintaining strong parent-child bonds*. *American Academy of Paediatrics*. 2006.

# Paediatric Rehabilitation

## INTRODUCTION

Disability in childhood can result from multiple conditions. The two main groups are a problem that arose before or as the child was born including genetic problems and those acquired after birth. These are listed in Table 35.1

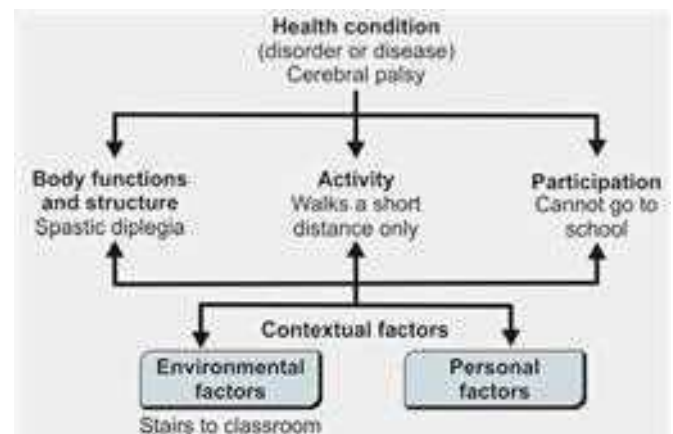
In medicine, doctors are trained to identify the medical problem and to manage that problem. “Suresh cannot walk very well and so cannot go to school.” Reading this statement it looks like it is Suresh’s problem and his fault that he cannot go to school. However, in recent years there has been a change in how we can look at a person. So, Suresh can walk using his walker but needs the ground to be smooth with no steps. Suresh’s classroom is on the first floor and the stairs stop him from going to school. Here we see that Suresh does have a problem. He also has equipment to aid him but the environment is a major barrier for Suresh.

The International Classification of Functioning, Disability and Health, also abbreviated as “ICF”, was approved by

the WHO in May 2001. The ICF recognises the complex dynamic interaction between the health of the child and environmental and personal factors (Fig. 35.1). This has replaced the previous classification of ICIDH (International Classification of Impairment, Disability and Handicap). The ICF enabled the focus to be shifted from ‘disability’ (cannot do) to ‘activity (ability to perform a task appropriate to age)’ and from ‘handicap’ to ‘participation’. The emphasis is taken away from the disease to its impact on what the child can do, “functioning” and the child’s ability to take part in everyday activities, in play and school. Both factors, the child’s functioning and participation, will determine the goals of rehabilitation. This information is used to determine the extent to which a child’s abilities can be improved through therapy and to what extent the environment can be changed to facilitate the child’s performance. Hence, disability in the above example does not reside in Suresh but in his environment, which prevents his participation in his community and school.

**Table 35.1:** Disability in children can result from the following conditions

<i>Acquired conditions</i>	<i>Developmental delay/ Congenital deficits or deformity</i>
Traumatic/Acquired brain injury (Hypoxia, infections)	Cerebral Palsy, Seizure disorder Hearing, visual, speech, learning deficits
Traumatic/Acquired (Demyelination/tumours) Spinal cord injury	Neural tube defects, Meningomyelocele, Hydrocephalus
Neuromuscular disease (Poliomyelitis, Guillain Barré Syndrome, Myaesthesia Gravis, Polymyositis)	Neuromuscular disorders (Spinal Muscular Atrophy, Duchenne Muscular Dystrophy, Becker’s dystrophy.)
Nerve injuries, e.g. Erb’s palsy	Hereditary sensory motor neuropathy
Juvenile arthritis, Haemophilic arthropathy	Joint deformities, e.g. Club feet, Arthrogryposis
Amputations due to trauma, tumours, burns	Congenital Limb deficiencies



**Fig. 35.1:** The International Classification of Functioning, Disability and Health (ICF)

## THE REHABILITATION PROGRAMME

Multipronged interventions aimed at various components of a child's disability (physical, cognitive, behavioural and psychosocial) can influence the outcome of a rehabilitation programme. Hence the rehabilitation team consists of the medical doctor (physiatrist/paediatrician), nurse, physiotherapist, occupational therapist, speech therapist, psychologist, special educator, social worker and orthotic/prosthetic depending on the nature of the condition.

In the *interdisciplinary* model of care, professionals from different disciplines perform evaluations independently and work towards the goals set in collaboration with the parents. In a child with multiple disabilities, various professionals provide therapy in their area of expertise, e.g. speech therapist for communication and swallowing, the physiotherapist for head, trunk and limb control and balance, occupational therapist for participation in daily activities and special educator for learning. However, in the *transdisciplinary* approach each of these members can interact jointly in way that any one of the therapist can provide the training needed.

The *collaborative* model of service delivery is based on being family-centered, integrating services and promoting outcomes that are meaningful to the child and family in daily life. This incorporates therapy into the natural learning environment (in the setting where children live, learn and play) which is based on the assumption that motor learning is optimised by frequent and varied practice within the context of daily activities and routines.

Interventions can be directed towards the child to:

- Optimise the abilities of the child
- Prevent/Reduce the secondary disabilities that occur due to the primary condition, such as contractures, dislocation of a hip, pressure sores and behavioural disturbances
- Enable the child to participate in life tasks and interact with his/her environment at home, school and at play
- Provide support and training to the family to continue therapy in the home setting.

### Rehabilitation in Brain Injury

An assessment of the child by the various team members helps in planning therapy and making goals for the child. Clinical assessments look at the child's performance in various domains. These include vision, hearing, speech, cognition, behaviour, motor and sensory system. The examination of each system is important, but the main purpose of assessment is to find out what the child can do and not do and the reason for it. Observing a child play by herself, with toys or with people is a quick and pleasant method of evaluating the child's motor control of their head, trunk, upper and lower limbs, hand functions, their eye hand co-ordination, cognition and behaviour.

### Developmental Delay

Early intervention refers to a programme which is implemented between birth and 3 years of age in those who have an established risk and have a delay in their development. This programme focuses on optimising the child's development milestone and includes the support of the family's ability to help their child. Two intervention models described are— activity focused and impairment focused intervention.

#### Impairment Focused Interventions

Impairment focused intervention includes sensory motor approaches, positioning to prevent contractures, range of motion exercises, strength, endurance and balance training.

##### (a) Sensory-motor approaches

The most common physiotherapy approach used in cerebral palsy is the Bobath Neurodevelopmental approach. Advances have been made in the Bobath approach, and it is currently regarded as a "concept" rather than a technique. The basic concept involves the inhibition of abnormal movement patterns and the facilitation of automatic postural reactions (righting and equilibrium reactions). The therapist/mother's hands are used for guided control of body parts along with other stimulation techniques to reduce the abnormal postural tone, improve postural alignment and control. This provides age appropriate sensori-motor feedback and encourages the appearance of mature reflexes which in turn will help in the development of functional abilities sequentially, such as head control (Fig. 35.2C), rolling (Fig. 35.2A), prone on elbows (Fig. 35.2B), sitting (Fig. 35.3A), standing and walking. This should be incorporated throughout the day by the parents in the way the child is positioned, carried and assisted for daily activities.

Therapy progresses according to the normal developmental milestone with a focus on functional performance, e.g. trunk control can be facilitated once head control is achieved (Figs 35.3B and 3C). Similarly, standing and ambulation can be facilitated once child has adequate trunk and hip control in sitting (Fig. 35.3D) and kneeling (Fig. 35.3E)/half kneeling.

##### (b) Management of impaired motor control

Deficits in the voluntary muscle contraction in children with cerebral palsy are thought to be due to decreased motor recruitment centrally and changes in the muscle morphology. Impaired voluntary control is also seen due to abnormality in motor tone resulting in *spastic* or *dyskinetic* cerebral palsy (also includes *athetoid*, *choreoathetoid*, and *dystonic* cerebral palsies). Goals are made with the family towards improving voluntary control, reducing spasticity and improving functional abilities.

The child must be able to understand the instructions to effectively participate in a programme aimed at improving voluntary control in the weak muscles. A progressive training





**Fig. 35.2A:** Early intervention where rolling is facilitated by the therapist's hand. Rolling is assisted by moving the pelvis and encouraging the child to turn his head and shoulders



**Fig. 35.2B:** Early intervention encouraging prone lying on the elbow, which encourages head control. Therapist assists the child to prop up on his forearms



**Fig. 35.2C:** Early intervention to facilitate head control. A rolled up towel is used to prop up the upper body and the child's head is supported by the therapist's hand. Mother uses a toy to get the attention of her child



**Fig. 35.3A:** A 4-year-old child with cerebral palsy. Facilitating symmetrical sitting position: Initially manual support will be needed along with verbal and visual (using mirror) feedback. The legs are positioned to stretch and reduce the tone in the adductors



**Fig. 35.3B:** Therapy on a rocker board to improve trunk control. The child learns to initiate balance strategies by adjusting her position to maintain her centre of gravity over the moving base of support



**Fig. 35.3C:** Using a therapy ball to improve trunk control. A slight movement in the ball will encourage the child to adjust her posture and trunk alignment and thus facilitate equilibrium and righting reactions to improve balance



**Fig. 35.3D:** Activities to improve standing balance with a walker—both ankles are supported with AFO's and knees with braces/gaiters



**Fig. 35.3E:** Kneeling with support to improve control of hip and trunk extensors. The support required to kneel can be gradually reduced as hip and trunk control improves



**Fig. 35.3F:** Gait training in parallel bars with ankle and knee supported with AFO and braces/gaiters. An adductor board is used to prevent scissoring



**Fig. 35.3G:** Gait training with a walker. Ankle and knees are supported with AFO and knee braces, and partial assistance is needed to propel the walker. A rod is placed between the legs, during the training period, to reduce scissoring

schedule is planned and this involves initially isolating the contraction of the desired group of muscles and then increasing its strength and endurance. Selective strengthening of antigravity muscles in the lower limb especially hip (Fig. 35.4A) and knee extensors helps to improve the gait pattern and efficiency. Strength training involves exercises against a particular resistance, e.g. free weight, resistance band, which load the muscle. The strength programme can also be

carried on through activities in occupational therapy, e.g. ball kicking for quadriceps strengthening. The endurance of these muscles is improved by increasing the number of repetitions of the activity. A record is made of the progress with therapy. Upper limb strengthening helps with performing transfers, wheelchair propulsion and use of assistive mobility device. Strengthening truncal muscles (Fig. 35.4A) help with static and dynamic (during activity) postural control in sitting and standing.

Neuromuscular electrical stimulation (NMES) is the transcutaneous application of an electrical current to elicit repetitive muscle contractions by stimulating the motor nerves or motor endplates. This helps in maintaining the muscle bulk, but is particularly effective when the child is able to initiate and enhance the muscle contraction voluntarily during the stimulation.

### (c) Management of impaired muscle tone

1. *Hypotonia*: This is seen commonly in congenital conditions like Down's syndrome, metabolic syndromes and occasionally in cerebral palsy. Therapy involves encouraging weight bearing and improving muscle power across the joints to help with stability. In cases with severe loss of tone, appropriate seating supports will be needed for head and trunk control.
2. *Spasticity*: An increase in the tone of muscles can negatively affect the child's functional abilities, such as sitting, standing, walking and other activities of daily living. It can be one of the most difficult aspects to manage and the cause of much disability due to pain, functional limitations, difficulty with maintaining hygiene and resulting complications like contractures, dislocations and pressure sores. An algorithmic approach to the management of hypertonia is presented in Figure 35.5. Specific interventions may include the following:
  - i. *Stretching programme*: Spasticity in muscles can be reduced by stretching them and strengthening their antagonistic muscles, e.g. strengthening of the hip abductors brings about a reciprocal inhibition in the adductors, so reducing tone in the adductors. Stretching can be maintained with an abduction pillow placed between the knees and used to keep the knees apart. Orthoses on the lower and upper limbs can be used to maintain a good range of movement in the presence of spasticity, e.g. resting splints for the hands provide a continuous stretch to extend the finger and wrist flexors and thus help in reducing tone.
  - ii. *Serial casting and orthoses*: Sometimes stretching is not enough to correct the contracture secondary to spasticity. Plaster of Paris casts are used to maintain a continuous stretch on the spastic muscles. Tone inhibition is also facilitated by hyperextension

of the toes, pressure under the metatarsal head, medial arch, a stable ankle position and deep tendon pressure along the tendoachilles. For example, to stretch the gastrocnemius, a cast is applied below the knee, keeping the ankle as close to neutral position as possible with the toes in 30 degrees of dorsiflexion with gentle moulding of the cast in the region of the medial arch and tendoachilles, before it sets. This enables the child to have a stable base to work on their standing balance and proximal muscle control. In the presence of hamstring tightness, the next cast should be reapplied extending above the knee; this will stretch both the gastrocnemius and the hamstrings. The casts have to be changed every week till the desired correction is obtained. Each new plaster is placed so the contracture is stretched more each time (Fig. 35.4B). Once neutral position is achieved, this is replaced by a tone inhibiting ankle foot orthosis (AFO) with a wedge of microcellular rubber added in the AFO to keep the toes dorsiflexed and another wedge to support the medial arch, or an AFO with a knee gaiter (Fig. 35.3F) or a KAFO (knee ankle foot orthosis) (Fig. 35.4C) if the knee extensors are weak, often in the presence of spastic hamstrings, to prevent a crouched gait.

- iii. *Pharmacological management*: Oral medications can be given to control spasticity, when a muscle or group of muscles are involved, causing functional limitation or difficulty with skin hygiene, e.g. when the fingers are clenched so the hand cannot be cleaned or the hips are adducted preventing perineal care and dressing. Oral medications are beneficial when a large group of muscles are involved but produce systemic side effect, such as fatigue and



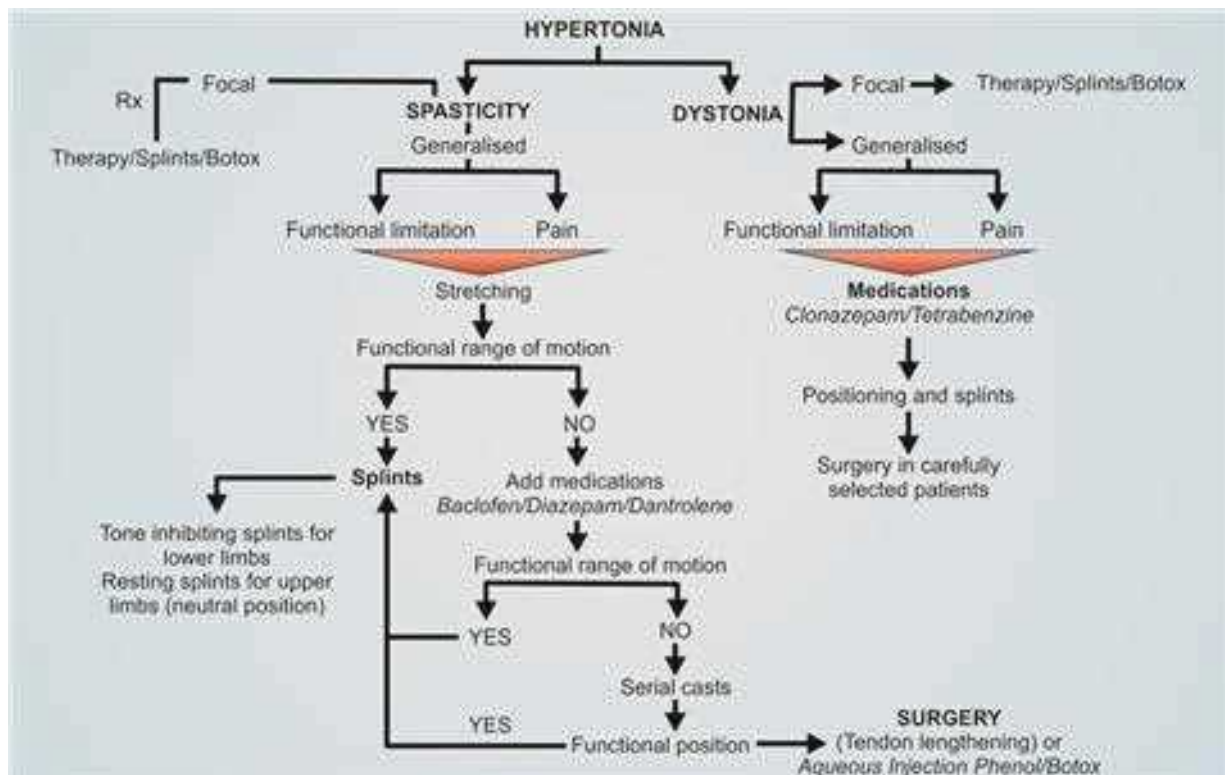
**Fig. 35.4A:** Pelvic bridging exercises by a 14-year-old boy with spastic diplegia, to improve strength of paraspinals and hip extensors



**Fig. 35.4B:** Serial above knee casts for correction of knee flexion deformity resulting from uncontrolled spasticity. Ambulation within parallel bars is started once the knee deformities are corrected below 30 degrees



**Fig. 35.4C:** Standing balance training with KAFO and elbow crutches



**Fig. 35.5:** Algorithmic approach to the management of hypertonia

**Table 35.2:** Pharmacotherapeutic options in the management of spasticity in children

Medication	Mechanism of action	Dose	Side effects
Dantrolene	Decreases the release of calcium into the sarcoplasmic reticulum of muscles	0.5 mg/kg BID, Max: 3mg/kg QID or less than 100 mg QID	Drowsiness, dizziness, fatigue, weakness of muscles causing impaired function, e.g. swallow, diarrhoea, hepatotoxicity
Benzodiazepines (a) Diazepam (b) Clonazepam	Facilitates the postsynaptic action of GABA	(a) 0.1–0.8 mg/kg/day in 2–3 divided doses (b) 0.01–0.03 mg/kg/day in 2–3 divided doses	Sedation, ataxia, fatigue, confusion
Tizanidine	Central $\alpha$ 2 receptor agonist	1–2 mg OD Max 36 mg /day	Hepatotoxicity, drowsiness
Baclofen	Analog of GABA, binds to GABA B receptors and decreases spinal stretch reflex	2.5–5 mg/day Max: 30 mg/day (2 to 7years), 60 mg/day (above 8 years)	Muscle weakness, drowsiness, fatigue, confusion, ataxia

drowsiness. These drugs can occasionally reduce the useful tone which helps the child in doing activities. For example, if the tone in the quadriceps is reduced, the child can experience difficulty with standing and walking. At times, children with an abnormal swallow and drooling may develop some worsening in these symptoms on starting antispasticity medications, with risk of aspiration. Table 35.2 shows a list of commonly used antispastic medications, their mechanism of action, doses and adverse effects.

Often oral medication is inadequate, cause unwanted side effects or seem excessive when only one muscle group is being problematic. Five percent aqueous phenol can be used for motor point block in muscles or for blocking accessible motor nerves by causing chemical denervation. Nerves with no sensory component are preferred to avoid dysesthesia following the injection. This is an economical and effective treatment, but the effects are very often permanent so care needs to be taken when deciding whom to treat with this modality. Commonly employed motor nerve blocks in the treatment of hypertonia are summarised in Table 35.3.

**Table 35.3:** List of commonly done motor nerve blocks

Nerve blocked	Joint effect and spastic muscle (supplied by Nerve)
Obturator nerve block	Hip adduction from adductor spasticity
Sciatic nerve block	Knee flexion and plantar flexion from hamstring and gastrosoleus spasticity
Peroneal nerve block	Ankle equinus from gastrosoleus spasticity
Femoral nerve block	Knee hyperextension or impaired knee flexion from Rectus femoris spasticity
Median nerve block	Wrist and finger flexor spasticity (FCR, FCU, FDS, FDP)
Musculocutaneous nerve	Biceps for elbow flexor spasticity

*Abbreviations:* FCR, flexor carpi radialis; FCU, felxor carpi ulnaris; FDS, flexor digitorum superficialis; FDP, flexor digitorum profundus

Intramuscular botulinum blocks the release of acetylcholine into the neuromuscular junction. This is beneficial in localised muscle group spasticity with the goal of improving a specific function, e.g botulinum injection into the wrist and finger flexors can help improve voluntary release of objects by reducing flexor spasticity. Parents need to be explained regarding the potential risk of local overflow causing dysphagia and dyphonia and systemic effects causing dyspnoea one to several weeks after the injection. The effects of botulinum toxin injections appear in 1–3 weeks and wear off by 6 months. The high cost and need for repeated injections makes this option viable only for a select group of children.

Subdermal implantation of an intrathecal baclofen pump enables direct delivery of the drug avoiding the general effects of sedation. However, this is expensive and at least 5% develop infection or other complications, such as pump failure.

(d) Management of movement disorders

Dystonia is the abnormal posturing of the any of the limbs, head or trunk due to sustained or intermittent involuntary co-contraction of muscles. Dystonia involving the muscles of the face, mouth, and oropharynx may result in dysarthria and/or dysphagia. Speech therapy will teach children how to make the sounds of letters and words and give them exercises to improve oropharyngeal muscle control. In children with dysphagia, optimal positioning in a supported seat with neck in neutral or slight flexion is required for safe swallowing. Consistency of the food is altered to thick fluids which are easier to swallow as compared to thin fluids. In those with oral hypersensitivity, the material of the spoon/cup should be gentle and smooth.

1. *Positioning:* Therapy involves looking for body positions and sensory inputs which can reduce the dystonia. The ataxic arm will show the greatest degree of past pointing when the hand is the greatest distance away from the trunk. Children soon learn this and are very reluctant to

stretch their arms far from their trunk! This is because the past pointing of the finger is the sum of the abnormal movements across each of the joints that are moving. So if the shoulder component moves 3 cm, the elbow 3 cm, the wrist 3 cm, etc. so the hand will move 9 cm. Treating ataxia is about providing a stable base of support to reduce the involuntary movements. A child will be sat in a chair and given support to the trunk and head, the arm will be supported on a table so the only part moving is the hand itself (Fig. 35.6). Eliminating the need to move parts of the body allows them to do tasks with less shaking and is a compensatory strategy, but also allows training to control the distal part. As the child learns to control the hand better, less support is given to the wrist and once this is better controlled, support is removed from the elbow.

2. *Therapy for balance and co-ordination:* The visual, vestibular and joint proprioception systems provide the sensory feedback required to achieve postural stability. Therapy for balance should also progress in a sequential manner, i.e. once head and trunk control is obtained then sitting balance can be worked on (Figs 35.3 A to C). Therapy is then progressed to balance in standing (Fig. 35.3D) and kneeling (Fig. 35.3E), and then standing on a single leg and then walking with a broad base to walking on a straight line. Frenkel's exercises are a series of exercises for co-ordination which begin



**Fig. 35.6:** Supported seating for a child with generalised dystonia involving head, neck, trunk and limbs. Supports are given to hold the head, trunk and feet in position. This chair will also require an abductor wedge to keep the legs apart. The child is now being trained to improve the control in his upper limbs

as simple movements in the direction where gravity has been eliminated and that gradually progress to more complex movements against gravity.

3. *Pharmacological management:* Oral medications used to reduce dystonia include tetrabenazine (synthetic benzquinolizine), trihexiphenidyl hydrochloride (anticholinergic) and clonazepam (Benzodiazepine). Tetrabenazine acts by inhibiting the uptake of monoamines into synaptic vesicles and hence diminishes their output at the synapses. Injection botulinum can be used, if there is localised dystonia as in spasticity with a goal of improving a specific function. Caution should be exercised in the surgical intervention for regional dystonia as it may cause a worsening of deformity in the opposite direction.

#### *Activity Focused Intervention*

This involves structured practice and repetitions of functional actions that increase independence in daily tasks.

##### (a) Self Care

The things that we do everyday to get washed, dressed, comb our hair, shave, eat and walk are called activities of daily living (ADL). It is important to remember the developmental stage of a child to identify and analyse the tasks which are difficult but meaningful for the child. The components of the task are then improved through specific therapy aimed at reducing impairments and activity based task with repetition, physical guidance and feedback.

A child learning to feed him/herself needs to be able to take the spoon to the plate, angle the wrist to then load the spoon, lift the spoon up to the mouth and put the spoon in the mouth. The child may have a problem lifting up the spoon. So exercises can be given to strengthen the ability to lift the arm. The child can practice feeding using a table that is higher than normal so the hand does not need to be lifted up so high. The child may be given a plate with "mock food" to practise lifting the spoon without actually eating the food. The challenge with these activities, is keeping them interesting. For teaching these skills each component of the task can be taught through techniques like chaining, modeling and prompting. In chaining, the child is enabled to perform one step of the task and the rest are completed by the caretaker. When the child becomes successful in one step the child is encouraged to attempt the next step in the sequence and so on till the whole task is mastered. Prompting involves use of physical or verbal assistance to help the child to learn a task. For example the mother holds the child's hand over the spoon to help him or her to learn to bring food to his/her mouth. In modeling the parent demonstrates how a task should be done and the child learns through imitation.

For toilet training the parents can be taught to make a schedule according to the child's frequency or pattern that has

been observed over a period of time. The child is taken to the toilet according to this schedule and rewarded appropriately.

#### (b) Behaviour modification

Behaviour modification techniques are used for both promoting adaptive behaviour like—learning to dress oneself, feeding, toilet training and for reducing maladaptive behaviour like head banging, biting or hyperactivity. Rewarding the child according to specific principles helps to develop acceptable behaviour in the child. Examples of reward include a favourite snack, toy, activities like—a trip to the park or lavish praise. Behaviour modification can also be used for teaching the child social skills and communication.

#### (c) Positioning

Appropriate positioning of children with equipment to hold the child's trunk, head and limbs, promotes their function and participation within the environment. This improves head control, permits greater freedom in use of upper extremities, improves ability to perform ADL, such as eating and dressing; improves postural alignment and decreases fatigue. Seating systems include—high chairs, strollers, static chairs, car seats, floor seats and wheelchair. These components which provide support in any seating system include arm rests, foot supports, lap tray, abductor wedge, pelvic belts, calf straps, head rest and cushions which also relieve pressure. The aim is to support the child in a position that makes it easier to do things and/or prevents complications. So the child is sat with the head supported and looking forward so they can see what is going on and to help communication (Fig. 35.7). The



**Fig. 35.7:** A 9-year-old child with cerebral palsy (total body involvement) using a wheelchair (which provides head, trunk and feet support) for mobility in and out of home. Her upper limbs are well supported on the lapboard and can be used for placing her food, play or learning activities

legs are held slightly abducted to reduce adductor spasms and reduce the chance of contractures. A child with complex physical disabilities needs their positioning to be controlled 24 hours a day.

Upright standing systems usually have a table or tray attachment that allows the child to play while standing. There are many varieties all with similar components. The feet are held in place with straps or blocks; the child's knees are kept extended with a strap in front of the knees, the hips are kept extended with a strap behind the hips and the body supported with a strap to a table anteriorly. Standing helps reduce tone, prevent contractures, improve bone density, facilitate the development of normal alignment and ankle, knee and hip joint development. Children should be encouraged to experience upright weight bearing position as close to the typical age of standing as possible if they have sufficient head and trunk control to be aligned correctly.

#### (d) Hand skills

Hand skills are essential for interaction with the environment. They are required for self care, learning, communication and playing. The following are the general methods for intervention:

- If a child has poor sitting balance, provide adequate trunk control through appropriate seating devices. Then the child's arms need not support the child and can be free to engage in play, writing, eating etc.
- Help the child to integrate tactile and proprioceptive stimuli through graded exposure to different shapes, textures, sizes and a variety of objects. Articles that can facilitate grasps are spoons, lids, balls, brushes, etc. Commonly available materials at home that can facilitate pinches are dry pulses, bottle caps, beads, coins and pebbles. The various components of hand function are tabulated in Figure 35.8 with illustrative examples in Figures 35.9A and B and 35.10.
- Reduce impairment in tone, range of motion and muscle strength, where possible.
- Introduce objects early through play. Do these using objects appropriate to the child's developmental status and in the sequence that parallels how hand function develops.
- Constraint induced therapy can be used in hemiplegics where the normal limb is restrained from functional use so that the child is forced to use the affected limb.

#### (e) Play

Play is a powerful therapeutic tool as it is the best way a child learns. Any activity or exercise can be turned to play with some aspect of adventure, surprise and freedom in it. The play activity should be chosen as per the child's level of development with a goal of moving him one step further. Toys provide stimulation for a child to play alone or

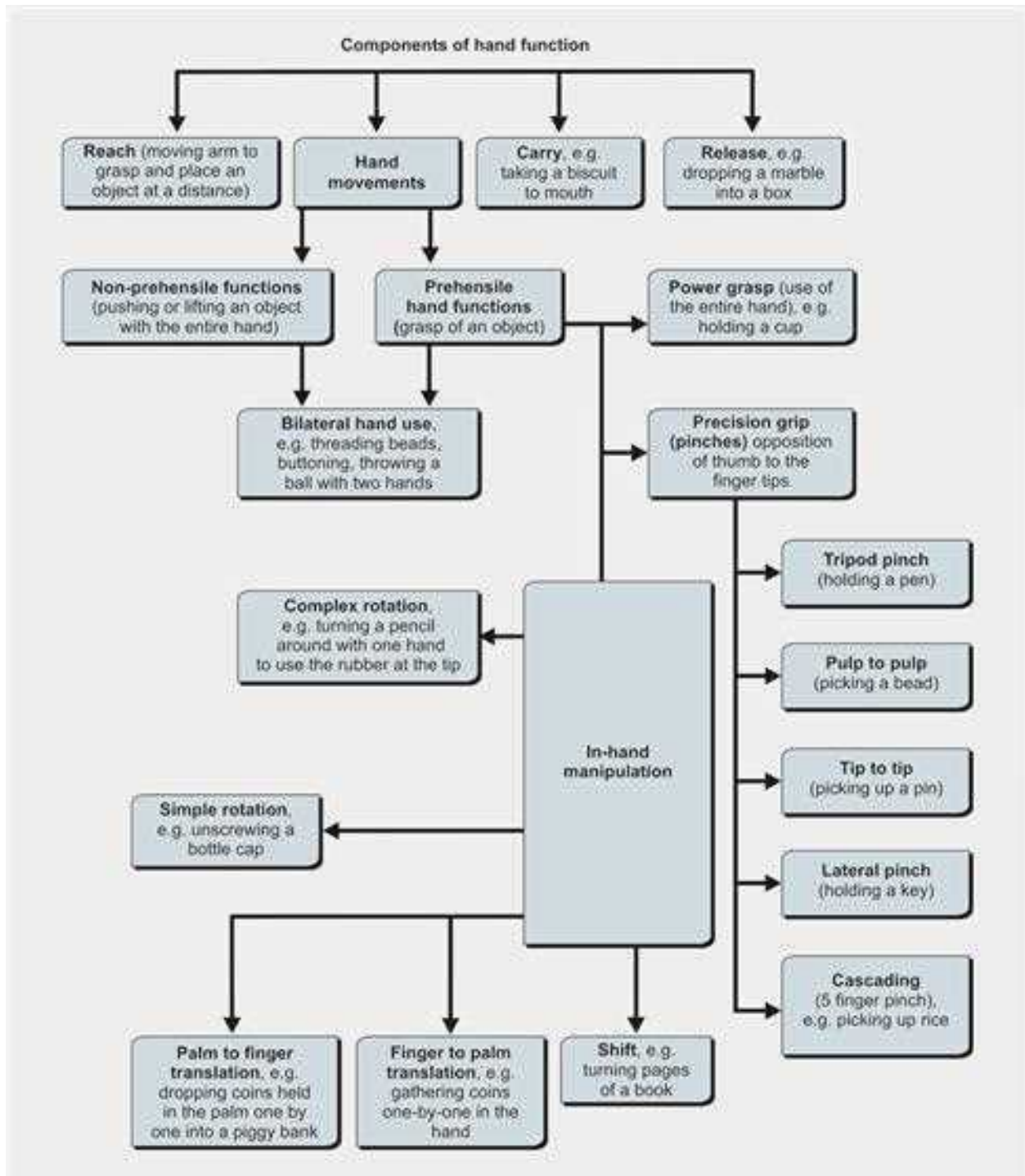


Fig. 35.8: Components of hand function





**Fig. 35.9A:** A boy with intrinsic muscle weakness of his hand, due to hereditary motor sensory neuropathy, is able to hold objects with a hook grasp



**Fig. 35.10:** A girl with cerebral palsy, practicing bimanual tasks (threading a string through cylindrical blocks/reels)



**Fig. 35.9B:** A splint which supports the thumb in opposition helps in achieving tripod pinch

with others. Play activities like dropping rings on to pegs, matching of shapes; jigsaw and block puzzles also enhance the development of eye, hand co-ordination and cognitive skills. Play activities like ball throwing enhances the use of both hands, as well as helps to improve trunk control.

#### (f) Assistive mobility

Mobility training is initially done in the parallel bars (Fig. 35.3F). An anterior or posterior walker can be used with or without wheels depending on the stability and the ease with which the child propels the walker. Energy expenditure as measured by oxygen consumption and oxygen cost is lower with the posterior walker as compared to the anterior walker. The posterior walker also facilitates a more upright walking and decreases the amount of double support time (Fig. 35.3G).

With improvement in the balance, gait pattern and endurance of walking, the child can progress to walking with elbow crutches (Fig. 35.4C) and subsequently with sticks.

Gait analysis is an important part of rehabilitation as it assists with planning intervention to optimise gait pattern and efficiency. Qualitative gait analysis involves observing the gait pattern in a clinical setting and analysing video in slow motion recording. Quantitative gait analysis looks at the range of motion (kinematics), moments of force and power generated or absorbed at each major lower limb joint and through the various phases of gait cycle (kinetics). Clinical decisions regarding interventions, e.g. whether AFO (ankle foot orthotics) is needed for ambulation, can be taken by comparing the gait parameters with and without AFO. Energy cost of ambulation or the physiological cost index (PCI) calculated from the gait analysis also assists with these decisions. Gait analysis is particularly helpful when planning for surgical intervention in children with spasticity as it helps in identifying the primary and compensatory gait abnormalities.

#### Assessment Tools

An assessment tool can be used to monitor progress and to communicate this with the family. Scales need to measure what you want them to measure (construct validity) and be reliable between different people (inter-rater reliability) and at different times by the same person (intra-rater reliability). These tools meet these criteria and are used by many rehabilitation facilities around the world. Responsiveness is another criterion that is needed for many patients. Small changes can make a big difference to a child and their family. The difference between walking 5 m and 50 m can make the

**Table 35.4:** Five dimensions with scoring key to measure gross motor function

Items	Scoring Key
(1) Lying and rolling	0 = does not initiate
(2) Sitting	1 = initiates
(3) Crawling and kneeling	2 = partially completes
(4) Standing	3 = completes
(5) Walking, running and jumping	NT = not tested

difference from needing someone to push a wheelchair to being independent walking at school. These tools can also be used as outcome measures in research.

The *gross motor function measure* (GMFM) is a standardised observational instrument designed and validated to measure change in motor function over time in children with cerebral palsy. The items are grouped into five dimensions with the scoring key shown in the Table 35.4.

The *gross motor function classification system* (GMFCS, expanded and revised, 2007) focuses on the motor performance in home, school and community settings (i.e. what they actually do) rather than what they are known to be able to do at their best (capability). These take into consideration the environmental and personal factors that impact the child's functioning. The GMFCS is a reliable and valid system that classifies children with cerebral palsy on the basis of the major age-appropriate gross motor activities, with particular emphasis on functional mobility.

Level I — Walks without limitations

Level II — Walks with limitations

Level III — Walks using a hand-held mobility device (Cranes, crutches, anterior and posterior walkers that do not support the trunk during walking).

Level IV — Self mobility with limitations; may use powered mobility.

Level V — Transported in a manual wheelchair.

The functional independence measure in children (WeeFIM) is a scale used to assess the daily functional performance of the child in three domains, i.e. cognition, mobility and self care. WeeFIM is categorised into two main functional streams: "Dependent" (i.e. requires helper; scores 1–5) and "Independent" (i.e. no helper; scores 6–7).

Scales that measure social functioning, participation in leisure and learning activities include the *paediatric evaluation of disability scale*, the Canadian Occupational Performance Measure (COPM), the Caregiver Priorities and the Child Health Index of Life with Disabilities (CPCHILD), and the Cerebral Palsy Quality of Life Questionnaire for Children (CP-QOL)

### Acquired or Traumatic Brain Injury

Interventions are decided according to the severity and type of neurological/musculoskeletal involvement. Early

intervention enables to optimise response to therapy and prevents complications which further delay rehabilitation. Severity of the Brain Injury is assessed by the Glasgow Coma Scale, which rates the eye opening, motor and verbal response on a scale of 3–15. In severe brain injury (GCS  $\leq$  8), look for response over time to various stimuli like visual, auditory, tactile, olfactory and proprioception. Multimodal stimulation programme involves observation of response to these, to see if child has the ability to localise or discriminate these stimuli. Movements are categorised as reflexive, spontaneous (without stimuli) or purposeful. Sensory Modality Assessment and Rehabilitation Technique (SMART) is a tool designed to assess the patient's response on a daily basis to optimise opportunity to observe the potential for functional and meaningful interaction with the environment and plan therapy accordingly. If child is unable to vocalize, but has consistent voluntary motor responses, these can be used as a method to communicate with the child, e.g. one blink of the eye can be used to indicate 'Yes' and two blinks as 'No'.

#### (a) Recovery continuum

COMA → Vegetative state → Minimal conscious state → Cognitive impaired states → Normal. Child is said to be in coma if eyes are closed all the time and reflexive movements are present only to noxious stimuli. A diagnosis of vegetative state is made if eyes are open with sleep-wake cycles, reflexive and withdrawal responses are present to stimuli. If there is any awareness of self or the environment a diagnosis of minimally conscious state is made.

#### (b) Management of respiratory system

Positioning for swallowing is crucial for prevention of aspiration. Elevation of the head end of the bed also reduces the risk of regurgitation at night. Chest physiotherapy which involves tapping the chest wall beginning laterally going to the midline and from below going up towards the sternum, enables the child to clear his/her secretions.

#### (c) Posttraumatic seizures

There is an incidence of 20–39% in the development of early seizures (i.e. within the first week of trauma) and antiepileptics are beneficial. Lower GCS and younger children are more prone for early seizures. However, there is no evidence for using prophylactic antiepileptics in the prevention of late onset seizures expect, in penetrating brain injuries.

#### (d) Cognitive/Motor deficits

The impairments following a brain injury will depend on whether the damage is focal or diffuse and the site involved. The goal of rehabilitation is to prevent secondary impairments like contractures and to help the child attain the maximum possible age appropriate function physically, cognitively and socially. As children become more responsive and

interactive specific therapy is given in the area of cognitive need (Speech, attention, memory, executive function, visuospatial functioning) or physical need (weakness, spasticity, hand functions, balance, gait). Concepts for therapy for these deficits are similar to what is practiced for children with congenital brain injury as mentioned in the section, Developmental delay.

Rehabilitation has become a continuum of care, being provided right from the acute care setting till transfer into the rehabilitation setting or the community and follow-up thereafter to facilitate acquisition of physical and cognitive skills. Early return to school is encouraged. Strategies need to be planned for the child with learning difficulties. An individual education plan can be made with help of the teachers who regularly communicates with parents regarding the child's overall performance.

### Rehabilitation in Spinal Cord Injury

Rehabilitation goals include prevention and management of secondary complications and maximising age appropriate functional independence as per the level of spinal cord injury.

#### *Spinal Cord Injury Due to Neural Tube Defects*

Spinal cord injury due to neural tube defect results in asymmetric motor sensory deficits. Muscle imbalances can result in deformities which can worsen as the child grows. Kyphosis, lordosis, scoliosis are commonly seen in those with thoracic lesions. This is controlled by positioning in bed with cushions and with a molded seat or a Thoracolumbosacral corset in sitting. Deformities in the lower limbs can be prevented by passive range of motion exercises, splints to maintain joints in neutral position (e.g. AFO) and active exercises to strengthen the weak muscles. The management of pressure sores, neuropathic bowel and bladder; self care and mobility issues are discussed in the section below.

#### *Traumatic/Acquired Spinal Cord Injury*

Patients with spinal cord injury present with specific issues which require attention from the rehabilitation perspective. These issues include:

##### (a) Autonomic dysreflexia

Noxious stimuli results in this autonomic dysfunction in those with spinal cord lesion at or above T6 level. Sympathetic over activity takes place below the level of injury resulting in hypertension. This in turn brings about vasodilatation above the lesion resulting in pounding headache, sweating, hot flushes and bradycardia due to vagal activity from the baroreceptor stimulation in the carotids. This is managed by sitting up the child and removal of the inciting factors for pain, as with a blocked catheter, anal fissure or in growing

toe nail. If high blood pressure persists with these measures, an antihypertensive like Nifedipine is given.

##### (b) Pressure sores

Pressure sore can be prevented by regular position change every 2 hours in the lying position and lifting up body with the support of hand (or by family) every 10–15 minutes while sitting to relieve pressure. Pressure areas like the region of the occiput, sacrum, ischial tuberosity, trochanter, both knees, heel and scapula should be examined daily. If there is any sign of redness or warmth, immediate measures should be taken in order to provide complete pressure relief in that area till the redness disappears. Nursing in prone position with foam/pillows to prevent pressure on the knees and genitalia is what works best when there are pressure sores in the posterior aspect of the body. Pressure relieving orthosis allows ambulation in a patient with chronic heel ulcer secondary to meningocele (Figs 35.11A to C).

##### (c) Deep venous thrombosis

Deep venous thrombosis is a complication seen spinal cord injury and presents with swelling of the leg. Elevated D dimer level is sensitive indicator but a color Doppler is needed to diagnose DVT. Pulmonary embolism is a life threatening complication of this and anticoagulants are started at the earliest.

##### (d) Heterotrophic ossification

Heterotrophic ossification (HO) is the abnormal calcification and ossification of soft tissues following a neurological insult. This presents as swelling, warmth and tenderness around a joint with limitation of range of motion. Aggressive therapy should be avoided till these acute signs of HO are



**Fig. 35.11A:** A chronic foot ulcer in a patient with meningocele



B



C

**Figs 35.11B and C:** Pressure relief is provided during ambulation with a PTB (patellar tendon bearing) Bohler orthosis. Height correction is provided in the footwear on the opposite side

present. This is managed with an analgesic (Indomethacin) or a Bisphosphonates (DiSodium etidronate). Serum Alkaline phosphatase is used to monitor activity of the heterotrophic ossification.

#### (e) Osteoporosis

Correction of vitamin D deficiency is important to prevent osteoporosis. Encouraging weight bearing also protects children from this long term complication

#### (f) Neuropathic bowel

Neuropathic bowel occurs due to impairment in the awareness of a full rectum and the ability to voluntarily

control bowel movements. Fecal incontinence occurs in a lower motor neuron (LMN) bladder in conditions like meningomyelocele, conus medullaris/cauda equina lesions due to a denervated anal sphincter resulting in dribbling of stools. Spinal cord lesions above the conus medullaris, results in an increased tone in the colonic wall and a anal sphincter (UMN bowel) causing constipation. Chronic constipation will result in spurious diarrhoea due to bacterial liquefaction of stools proximal to the obstruction.

A bowel programme is planned with the aim of attaining a predictable and adequate bowel evacuation. Digital stimulation (inserting a gloved finger into the anal sphincter and making gentle rotatory movements) or suppositories/enemas are used to empty the bowel by relaxing the anal sphincter and causing a local reflex due to the intrinsic colorectal nervous supply. However, in a LMN bowel this is absent and digital evacuation is used where the bowel is manually emptied. High fibre diet or substitutes are important to keep the stool soft and firm. A regular schedule is the key to success in a bowel programme which should be planned at the same time every day. The daily timing can be decided as per the pre-morbid timing if present or after a hot drink or a meal in the morning, which triggers the gastrocolic reflex.

#### (g) Neuropathic bladder

Neuropathic bladder resulting from spinal cord injury is best managed by Self Intermittent Clean Catheterization (SICC) which involves emptying the bladder at regular intervals by inserting a catheter into the bladder. This reduces the incidence of complications seen with the indwelling catheter, such as urinary infections and calculi formation. Other methods of emptying bladder include Credes (emptying by applying suprapubic pressure), Valsalva (straining by contracting abdominal muscles) and reflex voiding (local sacral reflex triggering uninhibited bladder contraction). These are regarded as unsafe if there is high post void residual urine, as this can result in recurrent infections and hydronephrosis.

#### (h) Self care

A child becomes independent in most of his/her activities of daily living by 5 years of age and this has to be gradually restored following a spinal injury or achieved in children with meningomyelocele. Learning of self-care activities requires adequate trunk control and hand functions. In tetraplegic children, supported seating and adaptive devices are given to assist with activities, e.g. universal cuff with a palmar pocket in the hand to hold a spoon to feed independently, place a pencil to write or to use a toothbrush.

#### (i) Mobility

Children with tetraplegia or high level thoracic lesions have poor trunk control and need a wheelchair for mobility. With training, a child is able to become independent on a manual

wheelchair on all terrains, including use of ramps and clearing of small thresholds. Children, whose level of injury is at C6 level or above, can be independent with a motorised wheelchair, although they will need assistance with their transfers from and onto the wheelchair.

Children with the level of injury between T4 and T10 will still require a manual wheelchair for community ambulation, but can use KAFO (knee ankle foot orthosis) for therapeutic walking within the house with the aid of a walker. A KAFO is made of light weight polypropylene to support the ankle in neutral position and metal uprights with a drop lock for the knee joint (Fig. 35.4C). Functional ambulation with KAFO and elbow crutches is the goal of rehabilitation for children with level of injury below T10. Stability in the absence of any hip muscles is provided by hyper extending the hip which makes the anterior iliofemoral ligament of hip taut. Ambulation with KAFO is started within parallel bars where hip hiking is used to forward the leg. Child then gradually progresses to gait training with a walker and then with elbow crutches. If child has adequate knee extension then ambulation can be achieved with an AFO.

### Rehabilitation in Neuromuscular Diseases

Nonprogressive neuromuscular disorders, such as Erb's palsy and poliomyelitis are characterised by lower motor neuron injury. Rehabilitation process involves range of motion exercises, positioning to prevent contractures and activities/therapy to improve/strengthen the weak muscles with the goal of improving functional performance and participation in home and school.

Duchenne muscular dystrophy is an example of a progressive neuromuscular disease where inherent sarcolemmal instability predisposes it to injury with mechanical loading. Here, a submaximal strengthening programme is recommended and these are incorporated into activities which children enjoy doing. Improvement in strength should translate in improvement in function and mobility or else compensatory strategies and adaptive devices are used (Figs 35.9A and B).

Aerobic exercises like walking, swimming, cycling, help to improve the cardiopulmonary system. These also have an effect on the muscles by increasing capillary density, mitochondrial size and density, oxidative enzymes and efficiency in utilisation of fat as an energy source for muscular activity.

### Management of Limb Contractures and Deformity

Contracture is the limitation in the passive range of motion of a joint and can be arthrogenic or myogenic in nature. These can result from the fatty infiltration and fibrosis seen in dystrophic myopathies along with muscle imbalance across

joints. Early diagnosis of contractures is important to initiate stretching exercises and the desired position is maintained with the help of resting splints. Encouraging weight bearing by standing and walking also helps in delaying the development of contractures in the lower limbs.

Correction of deformities should be pursued only if it results in a functional limitation. For example, an elbow contracture of more than 30 degrees can affect ambulation with elbow crutches and pronator tightness will limit supination which is required to bring food to the mouth and hence these need correction. In the presence of quadriceps weakness, the equinus deformity assists with ambulation by creating an extension moment at foot contact. Hence, the equinus deformity commonly seen in muscular dystrophies should not be corrected, except if the goal of rehabilitation is to provide gait training with knee ankle foot orthosis (KAFO) which helps in supporting the ankle and knee in neutral. Assistive devices like a walker or elbow crutches enable the children to walk longer than they would without them.

### Seating and Respiration

Supported seating in progressive conditions is essential to prevent or delay scoliosis. When functional ambulation is no longer possible, training in a wheelchair equips the child with skills needed to become as independent as possible. Spinal orthoses are usually ineffective in preventing progression of scoliosis and can restrict breathing. However, braces can be used temporarily to improve trunk control and sitting. Surgical correction of scoliosis by posterior arthrodesis is done after skeletal maturity when the growth of the vertebral column has been completed.

Progressive muscle weakness can lead to restrictive lung disease and ultimately to hypoventilation, hypercarbia and respiratory failure. Inability to clear secretions due to an ineffective cough results from weak expiratory muscles and this can lead to respiratory infections. Deep breathing exercises with or without an incentive spirometry and assisted cough techniques are used to ameliorate the effects of respiratory muscle weakness. Non invasive ventilation is an option in the later stages of respiratory difficulty due to low vital capacity and hypercarbia.

### Rehabilitation in Musculoskeletal Conditions

Joint damage and deformity occurs in conditions like juvenile idiopathic arthritis (JIA) and severe hemophilia (secondary to bleeds in the joints and muscles). In the acute phase, the goal of rehabilitation is to provide pain relief and rest the joint in a functional position by providing a splint, if needed. Ice is used in the acute phase for pain relief. Factor replacement is crucial for a child with acute hemarthrosis secondary to

hemophilia. A joint distension results in a flexed joint which is not functional and hence plaster of paris is used to make a splint to keep the knee, wrist and ankle in as much neutral position as possible. Stretching and mobilisation exercises are required for deformity correction particularly when functioning is affected (Fig. 35.13).

Heat is the modality chosen for pain management during the subacute phase in JIA as it is thought to improve the joint range of motion, by improving the tissue elasticity and reducing the muscle spasm from pain. Daily activity and ambulation are encouraged as early as possible. Progressive strengthening exercises are also initiated to reduce muscle wasting and osteoporosis (Fig. 35.12). This can be



**Fig. 35.12:** A girl with juvenile idiopathic arthritis does resistive quadriceps strengthening exercises



**Fig. 35.13:** A 10-year-old boy with haemophilic knee arthropathy, undergoes mobilisation and stretching for correction of a fixed flexion deformity. Serial casting was also used for correction of deformity and the right knee correction is now supported with a knee brace/gaiter

incorporated into play and recreational activities. Adaptive devices are advised for joint protection, e.g. built up pens/pencils, long handle brushes for bathing, large buttons, velcro straps for dressing, footwear made of microcellular rubber to support feet and reduce ground reaction forces proximally.

### Rehabilitation in Paediatric Limb Deficiency

The goal of prosthetic fitting and training in congenital or acquired limb deficiency is to achieve age appropriate milestones. Prosthetic fitting as early as 6 months of age helps in achieving sitting balance and training towards bimanual tasks and crawling. Early prosthetic fitting and training also helps with its acceptance by reducing stump dependence (Figs 35.14A and B). Parents should be involved in prosthesis decision making in order to ensure better acceptability, so that they encourage the child to use the prosthesis.



**A**



**B**



**Figs 35.14A to C:** A 13-year-old bilateral upper limb trans-radial amputee (post electrical burns) undergoing training to use a mechanical prosthesis for eating (A), building blocks (B), and right electric prosthesis for writing (C)

Once the child is cognitively ready for training, the passive prosthesis can be changed to provide the child simple control with hand opening and closing using cables or by switches within the socket of the prosthesis (electric hand) (Fig. 35.14C). Acceptance of upper limb prosthesis is lesser than that for lower limbs. This is due to the absence of sensory feedback and the inability to control the intensity of the grasp and manipulate objects. Very often children learn to use their stumps or their feet to do all their activities.

In lower limb deficiency, prosthetic fitting is started at 10 months of age when the child is ready to stand and then is subsequently made to walk. Knee joints are added at 3–5 years of age with a manual locking mechanism. In acquired amputations, preprosthetic training aims at improving range of motion, strength across the joint and reducing the postoperative swelling by rigid (plaster of paris) or

semirigid (elastocrepe bandage) dressings. Gait training is initiated with a temporary prosthesis till the stump edema has resolved. Good socket fitting and early ambulation with prosthesis improves compliance with its use. The prosthesis should be designed to accommodate for growth.

## SUMMARY

The concept of disability has undergone a paradigm shift in recent times. From being viewed as ‘disabled’ persons, it is now recognised that the ‘disability’ is in the environmental barriers and often in the way society responds to these people with special needs that limit their participation. A simple modification like a ramp with side rails instead of steps at school or moving the class to one on the ground floor, can improve accessibility for a physically challenged child like Suresh (Fig. 35.1).

Children with rehabilitation needs due to developmental or acquired pathologies require detailed evaluation and assessment by a comprehensive rehabilitation team which should include a psychiatrist, paediatrician, physiotherapist, psychologist, occupational therapist, rehabilitation nurse and social worker, among others. Realistic goals should be decided upon after discussions with the family and other caregivers. An individualised treatment plan can then be formulated based on the prioritized goals, taking into consideration the child’s emotional, social, as well as physical needs. All interventions that are considered should be with the aim of improving function as well as promoting integration into the family and community, maximising their potential for developing into productive members of society.

## ACKNOWLEDGEMENTS

We acknowledge the comments and suggestions of Dr Ashish S Macaden, DNB, PhD, and Dr Debbie Skeil, MRCP, FRCP, DM, in the preparation of this manuscript. Our heartfelt gratitude also goes out to our patients and their families who teach us through their struggles, and remind us of our common humanity.

# Prescribing for Children

## THE CHALLENGE

Prescribing for children presents a number of challenges. Children are not 'little adults' and should not be treated as such. Their bodies handle medicines differently to adults and the response of young children differs from older ones. Detailed care and attention is needed when making prescribing decisions for children, taking into account their developmental stage. Yet they experience the same range of illnesses that can affect adults. Children can require both specialised care for serious conditions such as cancer or transplantation and general care for more common complaints like asthma and diarrhoea. The paediatric prescriber requires a sound knowledge of the concepts of care within the whole age range of paediatrics. Neonatology can probably be regarded as a specialty in its own right with different clinical situations and huge differences in pharmacokinetics and dynamics.

The Table 36.1 below defines the descriptors commonly used for the different age groups, and the key stages, which define the development of a child.

Lack of evidence on the use of medicines in children leads to uncertainty in dosing and increases the risk of medication errors. Even the most appropriate dose may lead to differences in effectiveness and adverse effects to

**Table 36.1:** Descriptors used for different age groups

Descriptor	The age of the child	Key stages
Pre-term neonate	23–37 weeks	a. Rapid growth, fully formed gestation b. Most systems not fully developed.
Neonate	Birth to one-month	Normal initial period of human development and growth
Infant	One month to one-year	High growth rates and rapid changes
Child	One to 12 years	Slower growth and development
Adolescent	12–18 years	Final period growth and puberty, stretching into adulthood

those seen in adults. The evidence suggests that medication safety needs to be improved, particularly in babies and young children. Medication errors occur in children in hospital at similar rates to adults but have three times the potential to cause harm.

It is worth remembering that medicines are an important part of treatment strategies but a holistic approach to care of the child is required. Consideration also needs to be given to other approaches where possible including, for example, psychological management and nutrition.

Many changes occur in the way infants and children handle drugs in the period from birth to adulthood. They are important to take into consideration terms of understanding how doses are derived.

## PHARMACOKINETICS

### Absorption

Absorption of both orally and parenterally administered drugs is similar in children and adults. The exceptions to this are:

- Increased oral absorption of penicillin antibiotics
- Reduced oral absorptions of phenobarbitone, phenytoin and rifampicin in infants.

This is mainly due to decreased gastric acid secretion and an increased gastric emptying time at birth. Normal emptying times and pH are reached at about the age of three years.

Absorption from intramuscular (IM) administration is erratic, just as it is in adults, and the same types of drugs should be avoided with this route, i.e. phenytoin, digoxin and diazepam. The relatively small amount of muscle in neonates and infants means that IM injections are not only painful but relatively ineffective at achieving adequate drug levels. This route is, therefore, avoided whenever possible.

Percutaneous absorption is enhanced in infants and children. Their skin is much thinner and better hydrated than



adults' and this can lead to problems with topical steroids. This is particularly the case if the skin is broken or burnt. Potent topical steroids should be avoided as systemic adverse effects have been reported in infants. The skin is so thin in neonates (especially pre-term) that some substances designed for skin application in adults and older children may actually cause harm. This is true of some skin disinfectants such as Chlorhexidine 2% in ethanol which burns a premature baby's skin.

Rectal administration is particularly useful in infants and children who are vomiting or are reluctant to take oral medication. However, as in adults, there is considerable variation in individuals' blood supply to the rectum, causing variation in the rate and extent of absorption of rectally administered drugs. Diazepam can be given rectally and this is often the most convenient route in a child who is fitting. Paracetamol is also given rectally to treat pyrexia usually in children who are too ill to take their medication orally.

### Distribution

The two main factors influencing drug distribution are body composition and plasma protein binding.

#### Body Composition

Extracellular fluid volume is much higher in newborn infants (50%). It decreases gradually with increasing age, 25% at one year of age and 20–25% by adulthood. More importantly, total body water is much higher in premature infants (85%) than term infants (75%) and adults (50–60%). In addition, the body fat content changes dramatically with age, from 3% in a premature newborn to 12% in full term infants, 30% at one year and 18% in adulthood.

This tends to mean greater doses of water-soluble drugs, e.g. penicillin and aminoglycosides on a weight-for-weight basis are required. For example, the normal dose of IV flucloxacillin for a premature neonate is 25 mg/kg. If you were to give this to a 70 kg adult the dose would be 1.75 gm.

#### Protein Binding

In premature babies, plasma protein binding is reduced resulting in higher concentrations of free (active) drug. This is due to reduced levels of circulating proteins and a reduced ability to bind. Thus these patients have a higher apparent volume of distribution than adults. Phenytoin is an example where the increased proportion of free drug in the overall plasma level means that the therapeutic window in neonates (6–15 mg/L) is lower than in older children (10–20 mg/L).

### Elimination

The neonatal liver and kidneys are immature in their capacity to eliminate drugs. Both hepatic metabolism and

kidney function are reduced in premature babies resulting in increased plasma half-lives of both hepatically and renally cleared drugs.

This leads to longer plasma half-lives and increased plasma concentrations. The more premature the infant, the more depressed is the hepatic metabolism.

### Hepatic Metabolism

Enzyme systems in the liver are immature in newborn and pre-terms infants, particularly oxidation and glucuronidation. In the past this led to the 'grey baby' syndrome when large doses of chloramphenicol were administered to infants with meningitis. It also accounts for the much longer half life of diazepam in neonates.

In older children, hepatic function is greater than in adults. Most anti-epileptics and theophylline require a larger dose per kilogram than in adults to achieve therapeutic plasma concentrations. This is thought to be due to the fact that, relative to body size, the liver is larger than in adults.

### Renal Excretion

Renal excretion is the most important parameter, which affects dosing of children of any age. Renal function is immature in premature infants, leading to extended half-lives of drugs such as aminoglycosides or penicillins. Dosing changes are made in the same way as adults with poor renal function, i.e. increasing the dosing interval or decreasing the dose.

Conversely, patients with cystic fibrosis are able to clear aminoglycoside at a much higher rate than normal children of the same age. The reasons for this have never been fully explained but theories include enhanced tubular secretion, increased extra-renal clearance and increased volume of distribution.

These patients nearly always require much higher doses of aminoglycosides to achieve therapeutic plasma concentrations.

GESTATION (weeks)	GFR (ml/min)	GFR (ml/min/m <sup>2</sup> )
26	0.6	2
34	1	4
>34 to term	2–4	7–13
Term	4	13
Adult	120–140	70–80

## COMPLIANCE AND CONCORDANCE

Medicines should only be prescribed for children when absolutely necessary and always after careful consideration of the benefits of administering the medicine versus the risk involved from side effects and adverse drug reactions. It is important to discuss treatment options carefully with the child and the child's carer.

## Compliance

Factors that contribute to poor compliance with prescribed medicines include:

- Difficulty in taking the medicine, (e.g. inability to swallow tablets)
- Unpalatable formulation (e.g. unpleasant taste or unwillingness to administer medicines rectally)
- Purpose of medicine not clear
- Perceived lack of effectiveness
- Real or perceived side effects
- Difference between the carer's or child's perception of risk and severity of side effects from that of the prescriber
- Unclear instructions for administration.

## Concordance

The concept of compliance (the extent to which the prescriber's instructions are followed) is now giving way to that of concordance, where the patient is an active participant in decisions about treatment. Concordance is paramount between the health care professional, the child and the family. Time, effort and understanding are needed to achieve effective use of medicines in children. Children and parents need to be empowered to become active partners in discussions about the risks and benefits of their medicines. Their values and beliefs need to be taken into account as well as the effects of the proposed treatment on daily living.

## THE ISSUES IN PRACTICE

### Dosage Dilemmas

Choosing the most appropriate dose for children is no easy task. Their weight can range from around 0.5 kg for the very young to 120 kg for adolescents. However, adults' weight can also vary from 40–120 kg and no prescriber would think twice about giving any adult a 150 mg dose of ranitidine, for example, even though the plasma concentrations obtained will vary enormously. The difference is that we know this dose is safe and effective for most adults—there is less certainty in prescribing for children.

Most paediatric formularies will state that the ranitidine dose in children is 2 mg/kg, making a 26.4 mg dose for a 13.2 kg child. Ranitidine suspension comes as 15 mg/ml requiring the carer to draw up 1.76 ml. We know that decimal points are a major area of risk so would it be appropriate to give 2 ml (30 mg) to this same child?

The answer in this case is 'yes' as ranitidine has a wide therapeutic range in children just as it does in adults. Good practice would be to round the dose and avoid decimal points. The skill is to know when this is appropriate with individual drugs and how far rounding can be taken.

Although few drugs are licensed for children, we need to look at what the license really tells us. Let us take the example of aciclovir, which has a licensed dose for children of 10 mg/kg tds for under three months; 500 mg/m<sup>2</sup> tds for three months up to 12 years and 10 mg/kg tds for 12 years and over. (Note here that this particular license has different units of measurement for these age groups, depending on how trials were carried out). There is good evidence that these doses are safe and effective for these age groups. But should an 11-year-old be treated differently than a 12-year-old? How rigidly should these age-related criteria be applied? In practice an 11-year-old is often given a higher dose than a 12-year-old. It is important to ensure that whatever dose, and whatever source of information is being used, that treatment meets the needs of the individual child.

### Information Sources

Prescribers should always use reliable sources of paediatric dose information where these are available. However, the lack of paediatric data means that prescribers are occasionally left to extrapolate information from adult doses. Although this is plausible, it can also be dangerous. The metabolism and dynamics of babies, for instance, may be totally different to those in adults and may have unpredictable and serious adverse effects.

### Dose Calculation

Many methods have developed over the years for calculating doses in paediatrics. The percentage method and the mg/kg method are the only two that should be used.

#### Percentage Method (Surface Area Method)

The percentage method for estimating doses is calculated as follows:

$$\frac{\text{Surface area of child (m}^2\text{)}}{1.76 \text{ m}^2} \times 100 = \text{Percentage of adult dose}$$

(1.76 m<sup>2</sup> being the average adult surface area)

#### Weight Height and Body Surface Area

The Table 36.2 shows the mean values for weight, height and body surface area by age; these values may be used to calculate doses in the absence of actual measurements. However, the child's actual weight and height might vary considerably from the values in the table and it is important to see the child to ensure that the value chosen is appropriate. In most cases the child's actual measurement should be obtained as soon as possible and the dose recalculated.

Children are often said to tolerate or require larger doses of drugs than adults based on mg/kg basis. The percentage method helps explain this phenomenon.

**Table 36.2:** Mean values for weight, height and body surface area by age

Age	Weight kg	Height cm	Body surface m <sup>2</sup>
Full-term neonate	3.5	50	0.23
1 month	4.2	55	0.26
2 months	4.5	57	0.27
3 months	5.6	59	0.32
4 months	6.5	62	0.34
6 months	7.7	67	0.40
1 year	10	76	0.47
3 years	15	94	0.62
5 years	18	108	0.73
7 years	23	120	0.88
10 years	30	132	1.05
12 years	39	148	1.25
14 years	50	163	1.50
Adult male	68	173	1.80
Adult female	56	163	1.60

[Source: Reproduced by the kind permission of: Paediatric Formulary Committee. BNF for Children (edition, 2006) London: BMJ Publishing Group, RPS Publishing, and RCPCH Publishing Ltd; 2006].

Body water (total and extracellular) is known to equate better with surface area than body weight. It therefore seems appropriate to prescribe drugs by surface area if they are distributed in the extracellular water.

### Example

Iain is a three-month-old baby. He weighs 5.23 kg. His body surface area is 0.31 m<sup>2</sup>. Calculate the dose of aciclovir required for him using the percentage method (the adult dose is 800 mg).

$$\frac{0.31}{1.76} \times 100 = 17.6\%$$

Dose is  $0.176 \times 800 = 140.8$  mg

Use 140 mg = 3.5 ml of 200 mg/5 ml aciclovir suspension.

### Mg/kg Method

$$\frac{\text{Adult dose (mg)}}{70 \text{ kg}} = \text{mg / kg dose}$$

(70 kg being the average adult weight).

This method will give lower doses than the percentage method using surface areas. It is far less accurate in clinical terms but much easier to use since weights are usually more accessible than surface areas. Within limited age bands it

is appropriate to state doses on mg/kg basis. This form of extrapolation from adults is usually inappropriate for accurate therapeutic dosing, although it is unlikely to lead to toxic dosing.

### Example

Iain is a three-month-old baby. He weighs 5.23 kg. His body surface area 0.31 m<sup>2</sup>. Calculate the dose of aciclovir required for him using the mg/kg method (the adult dose is 800 mg).

$$\frac{800}{70} = 11.4 \text{ mg / kg}$$

Dose is  $11.4 \times 5.23 = 59.6$  mg

Use 60mg = 1.5 ml of 200 mg/5 ml aciclovir suspension.

Using body surface area to calculate drug dose is the most accurate method, because it reflects cardiac output, fluid requirements and renal function better than weight-based dosing. In practice, however, it is impractical and necessary for only a limited number of drugs, e.g. cytotoxic agents. Weight-based doses are mainly used. Doses based on age bands may be used for some drugs with a wide therapeutic index.

## PRESCRIBING IN PAEDIATRICS

### General

Good prescribing is essential in all patients. However there are key points of good practice in prescribing for children. They can be summarised as follows:

- Always prescribe so that anybody can read it
- Never prescribe or administer without knowing the allergy status of the child
- Always be as clear as you can with units: mg, micrograms, nanograms, units are acceptable: mcg, ng, ug, iu are not acceptable
- Decimal points must always have a number in front of them even it is a '0'
- Try to be logical with doses. There are a few drugs that need precise prescribing on mg/kg basis. Most drugs however can be rounded up or down with no clinical consequences (this reduces the use of decimal points and aids administration)
- Only medication with no strength (e.g. lactulose) or with multiple components (e.g. Abidec) can be prescribed in ml. All others must be in mg, micrograms or mmol for all electrolytes.

### Practical Issues

The lack of licensed drugs for children causes practical problems every day for the paediatric pharmacist, doctor, nurse, family and patient. These include a lack of dose information. Prescribing too small doses may result in

sub-optimal therapy, or over-dosing may lead to adverse drug reactions. Many paediatric dose reference sources are available but, in some cases, they provide conflicting advice. They tend to be based on local practice and experience rather than hard evidence. A reputable paediatric dose reference source should be used.

### Lack of Suitable Formulations

Children are often unable to swallow tablets or capsules and may be in danger of aspiration if they are pushed to do so. Palatable liquid formulations are needed to facilitate administration and accurate measurement of paediatric doses. Often these are not commercially available.

Suitable products such as oral liquid, powders or capsules may therefore have to be prepared extemporaneously. Little information may be available on the bio-availability of the drug or the physical, chemical and microbial stability of the preparation. The result is often unpleasant to take and the preparation will have a short shelf life.

### Extemporaneous Dispensing

Extemporaneous dispensing should be seen as a last resort. Standards of extemporaneous dispensing are extremely variable and mistakes have happened with devastating consequences. Currently there are no common regulations or guidelines to regulate extemporaneous dispensing. It may be performed in a highly equipped laboratory, in a licensed 'specials' manufacturing unit or in a hospital. In such areas, good manufacturing practice guidelines must be met and are enforced by regulatory authorities. This will involve trained personnel who are using strict checking and documentation procedures, suitable equipment and ingredients of a high standard, and are supported by appropriate quality assurance facilities. The whole production process is auditable in terms of ingredients used and personnel involved.

By contrast, extemporaneous dispensing can also be carried out on the dispensary bench in a community pharmacy, often with little equipment and documentation available. There are many variations between these extremes. Although some countries are developing, or have introduced, guidelines and standards, adherence is usually not a requirement. There needs to be a professional, ethical and legal obligation on practitioners to observe uniformed consistent standards in all areas where extemporaneous dispensing is performed.

Extemporaneous preparation also carries a health risk to pharmacy personnel. An extreme example is infertility and miscarriage in relation to cytotoxic drug handling. Measures are usually taken to ensure the safety of hospital and community pharmacy staff but much better facilities and standards of preparation are required in industry. It would be preferable for all such products to be prepared in a high quality environment to protect the staff involved, the product and the patient.

### Alternatives to Extemporaneous Dispensing

A range of options to extemporaneous dispensing is available including:

- Choosing an alternative drug that is commercially available in a more suitable form for administration
- Obtaining a paediatric formulation for a 'specials' manufacturer
- Using solutions prepared for injections by the oral route. This must be done with care as different formulations may include different salts and therefore have different bioavailability and stability. The pH of some injection solutions can cause problems and other excipients must be checked to be safe. The taste of many injections is problematic and the cost of using an expensive injectable form orally must be considered
- Cutting tablets to half or quarter size with a tablet cutter. This may help though it is inaccurate and dose equivalence is unlikely to be achieved
- Dissolving or dispersing tablets in water to make doses of less than a full tablet. Doses can be made up by dissolving a whole tablet in a specified volume and administering an aliquot of the resulting liquid with an oral syringe. Some tablets are soluble or dispersible even if they are not marketed as such. Having a list of such tablets can be helpful. There is a lack of research however to confirm the drug contents of aliquots of liquids when doses are measured in this way
- Importing licensed formulations from other countries may be a preferable alternative. However, difficulties around importation of free movement of medicines between countries can make this a complicated process. It is also expensive and gaining access to information on such product availability is not always easy.

### Excipients

It is important to be aware of inappropriate excipients in some medicine formulations (including some licensed products). The existence of colourings and preservatives has been highlighted in the press. Other examples include:

- A commercial formulation of Phenobarbital elixir containing 38% alcohol, which is clearly undesirable for children. It has been estimated that if a 5 ml (15 mg) dose was given to a 3 kg baby, this would be equal to an adult swallowing a couple of glasses of wine.
- Phenobarbital injection (200 mg in 1ml) contains 80–90% propylene glycol that can cause hyperosmolality if the injection is not diluted appropriately. The potential for toxicity is increased with babies and infants.
- Some excipients are undesirable in children with specific disorders. Children with phenylketonuria must avoid aspartame, for instance.

An EC Directive issued in 1997 stated that ‘benzyl alcohol is contraindicated in infants/young children’. This has implications for formulation of medicines used in children. Summary of Product Characteristics (SPCs) for amiodarone and lorazepam injections now both state that they contain benzyl alcohol and are contraindicated in infants or young children up to three years old. This poses a dilemma given the lack of more appropriate alternatives for these patients.

The sugar content of medicines must also be considered, particularly with long-term treatment. However, it is unlikely to be a major issue in short-term medication.

---

## OTHER ISSUES

### Medication Errors

The lack of suitable, licensed formulations for children increases the risk of medication errors by complicating administration. Frequently, a small proportion of the content of an injection vial is required to administer a calculated dose. Miscalculation can lead to a ten-fold or even a 100-fold overdose for a small baby from one vial. Dilution of adult strength injections is also often needed which can involve complex calculations. Fatal errors have indeed occurred.

Other complications are that displacement values must be taken into account and syringes have to be used carefully to avoid administration of the contents of the ‘dead space’ and overdosing with a concentrated drug.

Different reference sources quote doses in different ways. Some provide dose information as the total daily dose per kg bodyweight, which should then be divided into

the appropriate number of doses per day. Others give the individual dose per kg bodyweight and the number of times daily this should be administered. Errors are common due to confusion between these systems. It is therefore essential that prescribers are familiar with the way the reference works to minimise the risk of prescribing errors.

### Advanced Formulation

More advanced formulations are becoming increasingly available for adult patients, such as transcutaneous delivery system, fast dissolving drug formulations and multiple unit dose systems, which all offer potential major improvements. Generally, however, this new technology has not benefited children to a major degree so far. It is hoped that recent US and EU legislation will encourage research leading to the development of medicines and formulations designed specifically for children.

---

## ACKNOWLEDGEMENTS

Thanks are due to NES (Pharmacy), the Scottish Neonatal Paediatric Pharmacists Group, and particularly to Steve Tomlin and Sharon Conroy for permission to use and adapt their material for this chapter.

---

## BIBLIOGRAPHY

1. An Introduction to Paediatric Pharmaceutical Care. NHS Education Scotland (Pharmacy) 2009.
2. The British National Formulary for Children. BMJ Publishing Group Ltd/RPS Publishing/RCPC Publications Ltd 2006.

# Child Abuse and Neglect— How do We Protect these Children?

# 37

*“Investigation and management of a case of possible harm to a child must be approached in the same systematic and rigorous manner as would be appropriate to the investigation and management of any other potentially fatal disease.”*  
*The Victoria Climbié Inquiry 2003:*  
*Report of an Inquiry by Lord Laming, Para 1153*

## INTRODUCTION

Children, wherever they live, have the right to be protected from all forms of child abuse, neglect and exploitation. This should not be dependent on gender, race or culture. All human beings, including lay persons, professionals, business employees, politicians and governments, have an obligation to ensure that protection.<sup>1</sup> All have a responsibility for the welfare of children and should raise concerns speedily with appropriate persons or authorities should they believe or know that a child is being inappropriately cared for by their parents, carers or others.

## VARIOUS FORMS OF ABUSE

### Child Neglect

Aspects of neglect include:

- Neglect of a child’s physical needs for e.g. nutrition/hygiene/clothing.
- Not providing the child with opportunities to socialise with peers. This can be associated with attachment disorders.
- Scapegoating of one child over and above another, e.g. child constantly being unkempt and smelly and being told they are “useless” whilst other siblings are being complimented and are dressed in clothes acceptable to social norms.

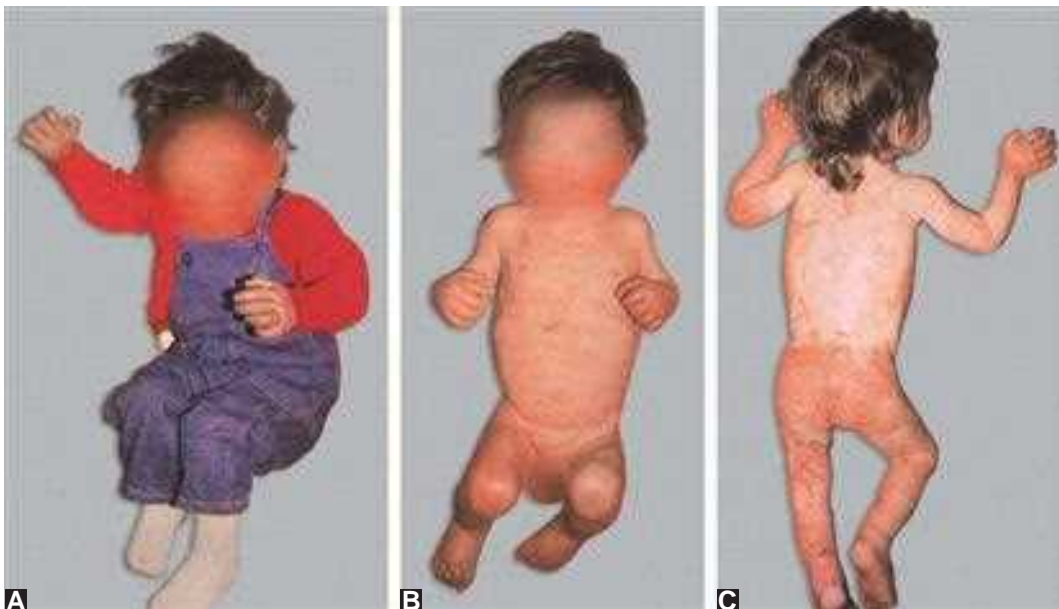
Neglect is usually a chronic or long-term situation which can have major consequences for the child’s self-esteem, development and life chances in general but episodic “acute” neglect can occur, especially at times of crises in the family or in escalation of parental issues such as mental wellbeing, domestic violence and addiction problems.

Neglect tends to be associated more with poverty and with lower social classes but it certainly occurs also in affluent families, particularly where children are left isolated, unsupported or unsupervised due to parents’ work commitments or even resentments at having to look after the children and care for them rather than their priority of life ambition and career.

### Recognition of Child Neglect

Health professionals can become concerned or suspicious of child neglect (Figs 37.1A to C) over a range of contacts with children and families e.g. concern may be raised from:

- A poor uptake of assessment of the child’s development at appropriate appointments or parents’ attitude to the child’s immunisations.
- Leaving diagnosed medical conditions untreated and not responding to sustained medical advice or giving what appears to be essential treatment regularly for a range of health problems.
- Frequent attendance at emergency departments (ED) with unusual injuries or other presentations which appear to be associated with accidents. These may have been preventable in the household setting or have occurred through a lack of supervision.
- A child being presented either at nursery or school or in other social environments dressed unacceptably, e.g. in a nightie walking outside late at night in cold weather unaccompanied.



**Figs 37.1A to C:** (A) Small unkempt child in a flexed position with red swollen hands (B) Note the same posture is maintained when undressed (C) How the child is emaciated—note the wasted buttocks and severe chronic nappy rash extending down the leg. Swollen lower legs are also seen. (Source: Hobbs C. *Physical Signs of Child Abuse*. London: WB Saunders, Co. Ltd; 1996.)

### Assessment of the Extent of Child Neglect

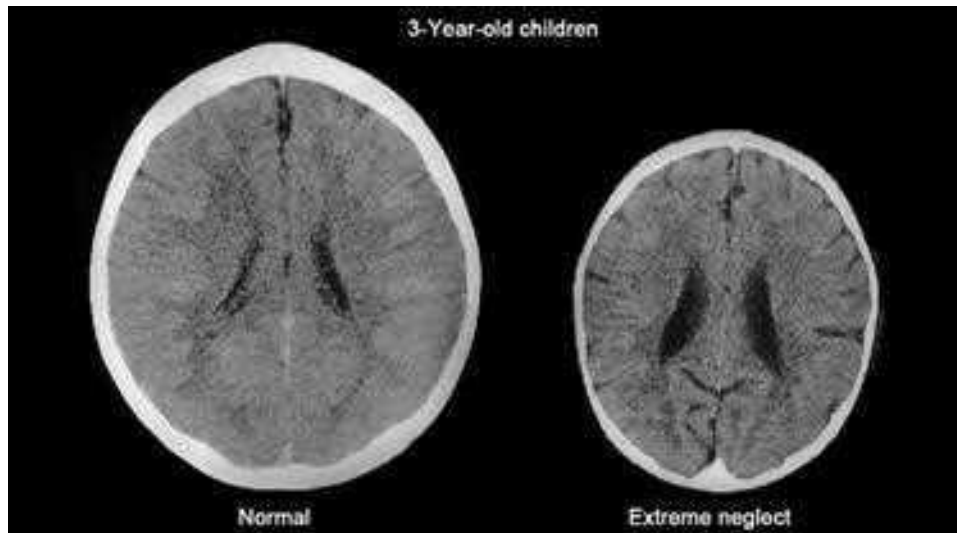
Many standardised tools can be used but the essential element is to gather all information from professionals surrounding and working with the child and family including the family practitioners, health visitor, school nurse, psychologist, school teacher, social worker and sometimes police if they have already been asked to attend due to the family, e.g. the child being left alone or found wandering without supervision at a young age. Other information must also be gathered particularly by social workers and police from neighbours, community volunteer workers or extended family members (Fig. 37.2).

The integrated assessment framework "triangle" assists all practitioners, including medical practitioners to glean robust detailed information about the individual child's needs, including the child's development, details with regard to parenting and whether there is adequate parenting capacity and/or appropriate standards of care as well as the social environmental circumstances within which the child lives. Key factors, such as poverty, unemployment and overcrowding, can contribute markedly to the chronic neglect of a child. The neglect is not necessarily a deliberate act, but may be the consequence of parental risk factors such as mental health problems or lack of capacity to parent. Other examples or risk factors are parental addiction to drugs or alcohol, domestic violence (gender-based violence) within the home or learning disability in parent or carer. In these situations, the neglect of the child can be by omission (not

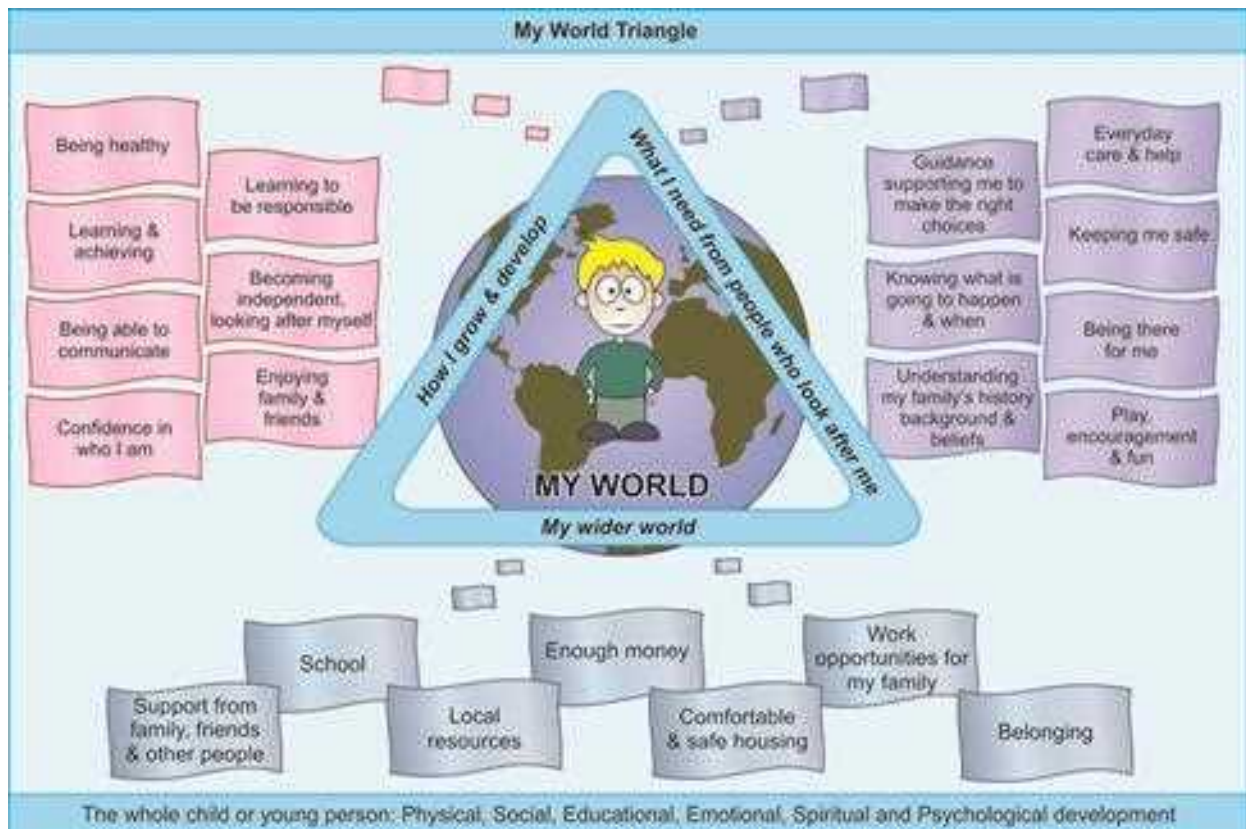
intended) or by commission. Nevertheless, it is the impact on the child in any case which must be seriously taken into account. Supportive intervention early and/or intervention to remove the child (at the most extreme end of circumstances) can be actioned but the child often lives for years in the context of neglect which has a major detrimental effect on emotional, cognitive and physical development. There is often a future generational impact and if the child has not been parented appropriately or has been abused, they often learn not to parent and the cycle is perpetuated throughout many future generations. That in itself leads to addictions, self-harm, low self-esteem and criminal behaviours. The following diagram shows the importance of the early detection and appropriate intervention in neglect cases (Figs 37.3 and 37.4).

The sharing of information between professionals involved with the child or families is critical. This should not be obstructed by simply bureaucratic notions of "confidentiality". Confidentiality must be in the best interest of the children as our patients. That is between professionals involved in children's services but also professionals involved in adult services, particularly those of mental health learning disability, addictions and where adult practitioners such as the general practitioner may become aware, e.g. that there is violence within the family home. There is substantial evidence that children living within violent homes are at very high risk of physical abuse and sustained impact on their emotional development.

It is absolutely essential that professionals have a low threshold of suspicion for neglect of a child's welfare (Fig. 37.5)



**Fig. 37.2:** Abnormal brain development following sensory neglect in early childhood. The image on the right is from a three-year-old child suffering from severe sensory-deprivation neglect. This child's brain is significantly smaller than average and has enlarged ventricles and cortical atrophy. (Source: Bruce D Perry. Childhood experience and the expression of genetic potential: What childhood neglect tells us about nature and nurture. *Brain and Mind*. 2002;3:79-100.)

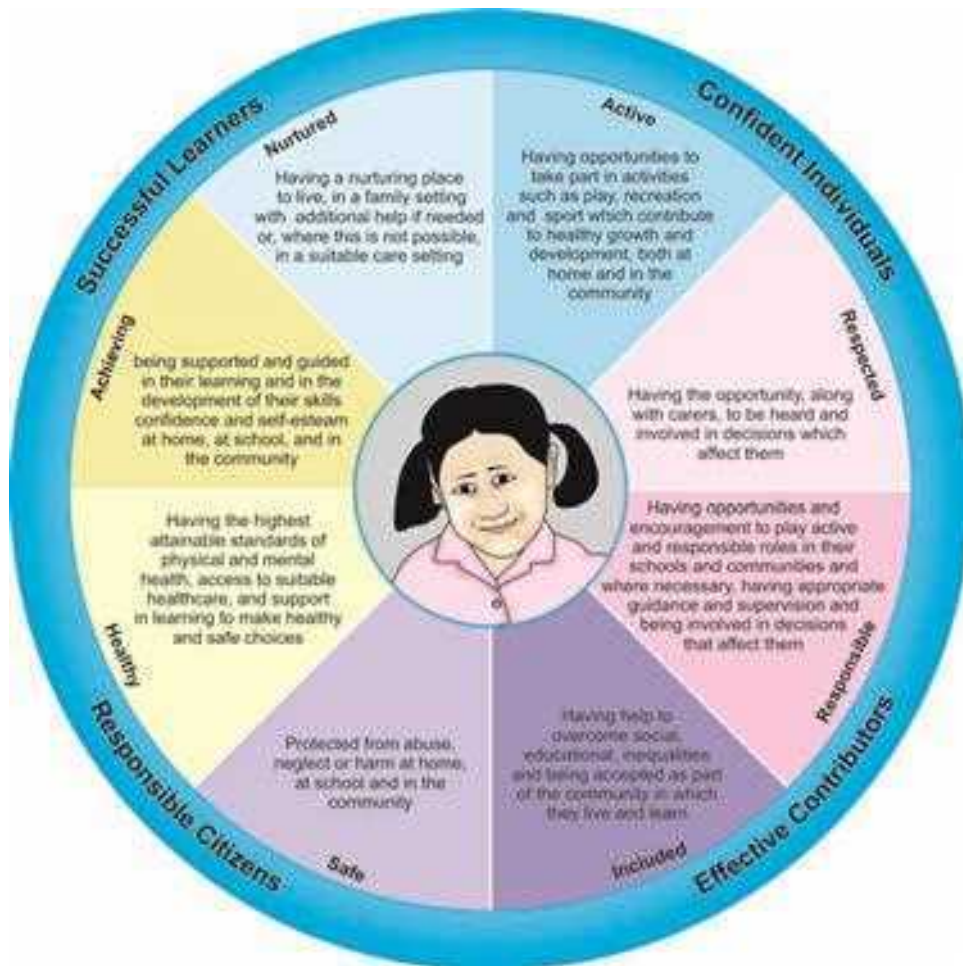


**Fig. 37.3:** My world triangle

[Source: Getting it right for every child (GIRFEC), Scottish government, 2009]

[www.scotland.gov.uk/Topics/People/Young-people/Childrenservices/Girfec/Practitioners/Tools](http://www.scotland.gov.uk/Topics/People/Young-people/Childrenservices/Girfec/Practitioners/Tools) Resources





**Fig. 37.4:** Factors that contribute to children developing into successful learners, confident individuals, responsible citizens and effective contributors

[Source: Getting it right for every child (GIRFEC), practitioner tools and resources, 2008]

such that their analysis and assessment can occur and appropriate interventions and support can be implemented early in the child’s life to enable the family to encourage nurturance of the child and ensure optimal physical and emotional development in the future. Where that is not sustainable, then local child protection statutory measures (dependent on different procedures in different countries) must be enacted to ensure the child’s safety and further development. This requires a dynamic process of assessment and the ability to intervene in a range of ways which fit every individual and child’s needs in the context of their family and community setting.

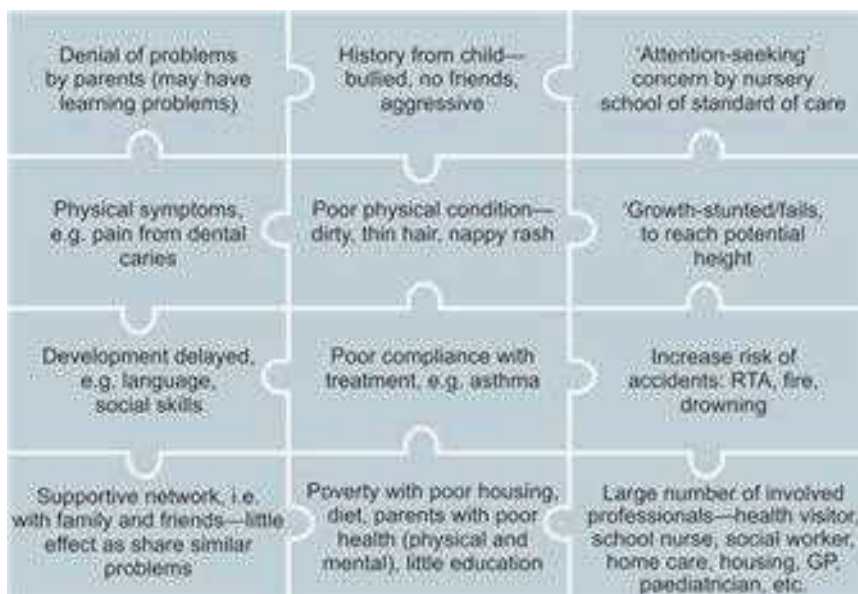
Often families will be resistant to these measures and there must be legal fallback position to ensure that the child is at the heart of interventions. Continuing neglect has such a profound impact on their longer-term development and on future generations. The Figure 37.6 shows impact of neglect on child’s growth.

## Parental Risk Factors

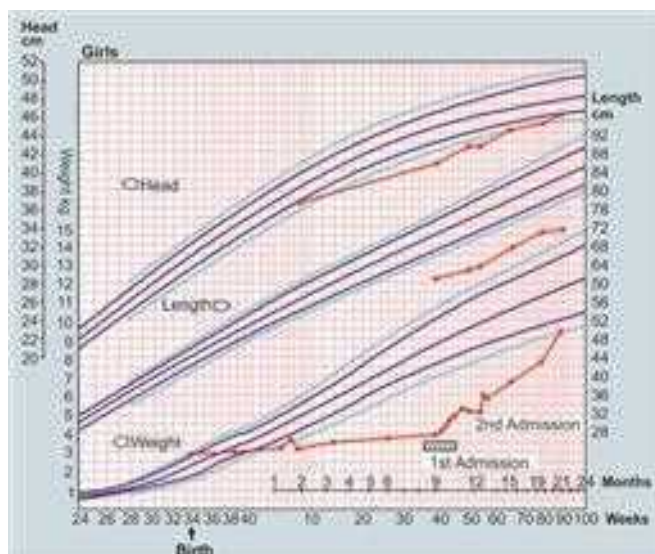
### Parental Substance Misuse

Parental substance misuse is associated with a range of potential risk to children including:

- Harmful physical effects on unborn and new-born babies.
- Impaired patterns of parental care with a higher risk of emotional and physical neglect or abuse.
- Chaotic lifestyles which disrupt children’s routines and relationships, leading to early behavioural and emotional problems.
- Family income may be diverted to buy alcohol or drugs, leading to poverty, debt and material deprivation.
- Unstable accommodation or homelessness as a consequence of anti-social behaviour orders, rent arrears or conviction for alcohol or drugs related offences.



**Fig. 37.5:** A range of factors can contribute to the picture of child neglect—often there is accumulative concern with regard to one factor or several



**Fig. 37.6:** This growth chart shows rapid increase in weight of a child following two separate admissions to hospital

- Children having inappropriately high levels of responsibility for social or personal care of parents with problem substance use, or care of younger siblings.
- Isolation of children and inability to confide in others for fear of the consequences.
- Threat of domestic abuse.
- Disrupted schooling.
- Children's early exposure to and socialisation into, illegal substance misuse and other criminal activity.

- Parents' reduced awareness or loss of consciousness may place children at physical risk in the absence of another adult who is able to supervise and care for them.
- Careless storage of medication and disposal of needles and syringes may cause accident or overdose.
- Repeated separation from parents when parents attend detoxification or rehabilitation facilities, or are in prison, or leave children looked after by multiple or unsuitable carers.
- Multiple episodes of substitute care with extended family or foster carers.

All agencies supporting adult alcohol or drug users should ask new attendees:

- Are you a parent?
- How many dependent children live with you?
- Do you have any children who live with others or are in residential care?
- What is your child(ren)'s age and gender?
- Which school or nursery or other pre-school facility do they attend?
- Are there any other relatives or support agencies in touch with your family who are supporting the child(ren)?
- Do you need any help looking after children or arranging childcare?

### *Parental Mental Health*

Parental mental health problems have a significant effect on the wellbeing of children and can lead to harm. In a report of 100 cases of fatal child abuse, there was parental psychiatric

morbidity in 32% of the cases which included depression, post-natal depression and personality disorder.<sup>2,3</sup>

The crossing bridges family model is a useful framework that can help staff to consider the parent, the child in the family as a whole when assessing the needs of and planning care packages for families with a parent suffering from a mental health problem.<sup>4</sup>

- Parental mental health problems can adversely affect the development and in some cases the safety of children.
- Growing up with a parent who experiences mental health problems can have a negative impact on the young person's adjustment into adulthood including their own transition to parenthood.
- Children, particularly those with emotional, behavioural or chronic physical difficulties, can precipitate or exacerbate the mental ill health in their own parents, therefore, increasing risks.

Public concern has arisen because of a number of high profile cases where children have been directly harmed, sometimes fatally because of the mental health problems of their parents or carers. Common themes emerging from these cases include:

- Lack of professional awareness of the impact of parental mental health problems on children.
- Individual agencies and their staff being unaware of, the presence of children within households.
- Lack of any clear assessment of the needs, situation and circumstances of children. In addition, services being too focused on the needs of adults and ignoring or lacking sensitivity to the needs of children and families.
- Ineffective communication between professional staff and between agencies including lack of interpretation of the health information provided with clarity to other agencies.
- Inconsistent recording linked to the issue of poor assessment of children.
- Poor evidence as to why decisions to act or more importantly not to act have been taken.
- Professionals not acting to help children soon enough resulting in crises arising and actual harm or tragedies happening.

### *Domestic Violence*

Domestic violence is a term describing a continuum of violent behaviour within an intimate relationship or close family situation. It can include verbal, financial, sexual, emotional or physical abuse. Domestic violence and child abuse, whether physical or emotional, often co-exists. In a National Children's Home (NCH) Charity Study from 1994, 75% of

mothers in homes where domestic abuse was occurring said that their children had witnessed violent incidents and 33% of the children had seen their mothers beaten. Ninety percent of children were present in the same or the next room at the time of the assault.<sup>5</sup> Quite a number of women are abused in pregnancy and in a study by McWilliams et al. in 1993, in relation to 127 women in refuges in Northern Ireland, 60% had been abused in pregnancy, 13% had lost their babies as a result and 22% had threatened miscarriages.<sup>6</sup> There are many effects on the child including lacking in self-confidence, withdrawn, constantly anxious, constantly fearful, difficulties in forming relationships, sleep disturbances, post-traumatic stress disorder, non-attendance or poor attendance at school (NCH, 1994).<sup>7</sup>

Health professionals have a key role in recognising domestic abuse and in referring appropriately to other agencies so optimal and sensitive assistance can be offered to the child and non-abusive parent.

### *Parental Learning Disability*

People with a learning disability need help with everyday living. This means that people with a learning disability need help in at least one of the following skill areas:

- Conceptual skills—receptive and expressive language, reading and writing, money concepts.
- Social skills—interpersonal, responsibility, self-esteem.
- Practical skills—personal activities of daily living (eating, dressing, mobility and toileting). Instrumental activities of daily living (preparing meals, managing money, housekeeping activities).

The prevalence of communication difficulties is estimated at between 50% and 80% in people with a learning disability.

Forty percent to sixty percent of children born to parents with a learning disability are removed from their care.

Learning disabled parents are 30–60 times more likely to be subject to a care order application than their numbers in the community would predict.

Parents with intelligence quotient (IQ) less than 60 experience more difficulty in cognitive functioning and social skills.

What do we know about parents with learning disabilities?

- Purposeful abuse by parents is infrequent.
- Neglect—omission not commission. Family pattern is repeated "I don't know what I'm doing wrong."
- Cognitive functioning and ability to learn
  - Uncertainty in literature regarding the effectiveness of training
  - Input needs to be longer-term
  - Maintaining skills, forgetting, failure to generalise, adjusting parenting styles as child grows

- The greater the discrepancy between parents' knowledge, skills and experience and the needs of the children, the higher the degree of risk.<sup>8</sup>
- Vulnerability to psychopathology.<sup>9,10</sup>
- Forty five percent depression and anxiety.
- Obsessive compulsive disorder (OCD) in females more severe.
- Study by McGaw looking at high-risk versus low-risk parents found experience of trauma by mothers to be significant for child protection registration for emotional abuse in children (79%).
- Health
  - Mothers with learning disabilities are at particular risk for poor health status.
- Common health problems in learning disability (LD)-department of health (DOH)
  - Mobility problems
  - Respiratory problems
  - Psychiatric disorders
  - Behavioural problems
  - Obesity
  - Eyesight problems
  - Health problems
  - Communication problems.

It has been stated that often the presence of a major medical condition in mother is one of the prime reasons for removal of a child from a family.

The difficulties experienced by parents who have a LD often overlap with those experienced by families of poor economic status.

Mothers with LDs tend to be isolated from their local communities.

Key risk factors for abuse where parents are learning disabled are:

- Presence of male IQ more than 70. Two LD parents were of less note in terms of risk to child than where male in household had IQ more than 70
- Higher risk are:
  - Previous children on child protection register
  - Mother had history of trauma (physical, emotional, neglect)
  - Physical/sensory impairment p more than 0.5
  - Special needs in children.

Improving outcomes for disabled parents and their children:

- Accessible information and communication.
- Clear co-ordinated referral and assessment procedures, processes, eligibility criteria and care pathways.
- Support designated to meet the needs of parents and children based on assessments of their needs and strengths.

- Long-term support where necessary.
- Access to independent advocacy.

## EMOTIONAL ABUSE AND NEGLECT

This must be considered when there is concern that the parent or carer-child interactions may be harmful. Examples include:

- Negativity or hostility towards a child or young person.
- Rejection or scapegoating of a child or young person.
- Developmentally inappropriate expectations of or interactions with a child, including inappropriate threats or methods of disciplining.
- Exposure to frightening or traumatic experiences, including domestic abuse.
- Using the child for fulfilment of the adult's needs (for example, children being used in marital disputes).
- Failure to promote the child's appropriate socialisation (for example, involving children in unlawful activities, isolation, not providing stimulation or education).

Suspect emotional abuse when persistent harmful parent or carer child interactions are observed or reported. Consider child maltreatment if parents or carers are seen or reported to punish a child for wetting despite professional advice that the symptom is involuntary. Consider emotional neglect if there is emotional unavailability and unresponsiveness from the parent or carer towards a child and in particular towards an infant. Suspect emotional neglect if there is persistent emotional unavailability and unresponsiveness from the parent or carer towards a child and in particular towards an infant.

Consider child maltreatment if a parent or carer refuses to allow a child or young person to speak to a healthcare professional on their own when it is necessary for the assessment of the child or young person.

Additionally, consider child maltreatment if a child or young person displays or is reported to display a marked change in behaviour or emotional state, as per the examples below:

- Behavioural change which is a departure from what would be expected for their age and developmental stage and which is not explained by a known stressful situation, e.g. bereavement or parental separation or a medical cause.

Examples of where child maltreatment should be suspected include:

### Emotional States

- Fearful, withdrawn, low-self esteem

## Behaviour

- Aggressive, oppositional
- Habitual body rocking.

## Interpersonal Behaviours

- Indiscriminate contact or affection seeking
- Over-friendliness to strangers include healthcare professionals
- Excessive clinginess
- Persistently resorting to gaining attention
- Demonstrating excessively "good" behaviour to prevent parental or carer disapproval
- Failure to seek or accept appropriate comfort or affection from an appropriate person when significantly distressed
- Coercive controlling behaviour towards parents or carers. Very young children showing excessive comforting behaviours when witnessing parental or carer distress.<sup>12</sup>

## Assessment of Emotional Abuse

Neglected children may present with:

- Failure to thrive through lack of understanding of dietary needs or a child or inability to provide an appropriate diet; or they may be present with obesity through inadequate attention to the child's diet.
- Craving attention or ambivalent towards adults, or may be very withdrawn.
- Being too hot or too cold—check hands/feet for cold injury with red swollen and cold hands and feet or they may be dressed in inappropriate clothing.
- Consequences arising from situations of danger—accidents, assaults, poisoning, other hazards (lack of safeguarding).
- Delayed development and failing at school (poor stimulation and opportunity to learn).
- Difficult or challenging behaviour (failure of parenting).
- Unusually severe by preventable conditions owing to lack of awareness of preventive health care or failure to treat minor conditions.
- Health problems associated with lack of basic facilities such as heating.

Additional risk of neglect may be present for children with disability and chronic illness. These may be associated with the child's environment, lack of service provision, family circumstances and society's attitude towards disability.

Parenting issues may impact on the parent/carer's ability and motivation to meet the needs of the child. These include:

- Learning disabilities
- Mental health problems

- Substance or alcohol abuse, including binge drinking
- Domestic violence
- Disability
- Chronic illness
- Unemployment or poverty
- Homelessness
- Young lone parents.<sup>13</sup>

## PHYSICAL ABUSE

Physical abuse (inflicted injury) otherwise known as "non-accidental injury" (NAI). Types of injuries in infants that may cause concern:

"Those who don't bruise, rarely bruise".<sup>14</sup> A systematic review of the international literature in infants under the age of 6 months suggests that any bruise in an infant under 6 months must be fully evaluated and a detailed history taken to ascertain consistency with the injury. The under one's in general are a particularly at risk group for various physical injuries. Non-mobile children should not have bruises without a clear and usually observed explanation. Certain areas are rarely (less than 2%) bruised accidentally at any age including neck, buttocks and hands in children less than 2 years (Fig. 37.7).<sup>13</sup>

Common and Important Sites for Non-accidental Bruises are:

- Buttocks and lower back
- Slap marks on side of the face, scalp and ears
- Bruises on external ear
- Neck, eyes and mouth
- Trunk, including chest and abdomen
- Lower jaw.

The face is the most commonly bruised site in fatally abused children (Figs 37.8A and B to 37.11). It is important on all parts of the body to look for patterns such as fingertip marks, implement marks, belt, stick or other object marks (Figs 37.8A to D to 37.11). Obviously differential diagnosis includes bleeding disorder, drug induced bruising either accidentally or deliberate, birth mark including Mongolian blue spot, cultural practices including cupping or coining.

## Bites

Bites are always non-accidental, though they can be animal or human (adult or child). Human bites are mostly paired crescent shaped arches of bruises (Fig. 37.12). Since a set of crescentic marks are small it should not be assumed that it is a child bite mark as they can be due to the contact, simply being from the upper and lower incisors of an adult. Individual teeth marks may be seen, the marks may be distorted by the contours of the area bitten.

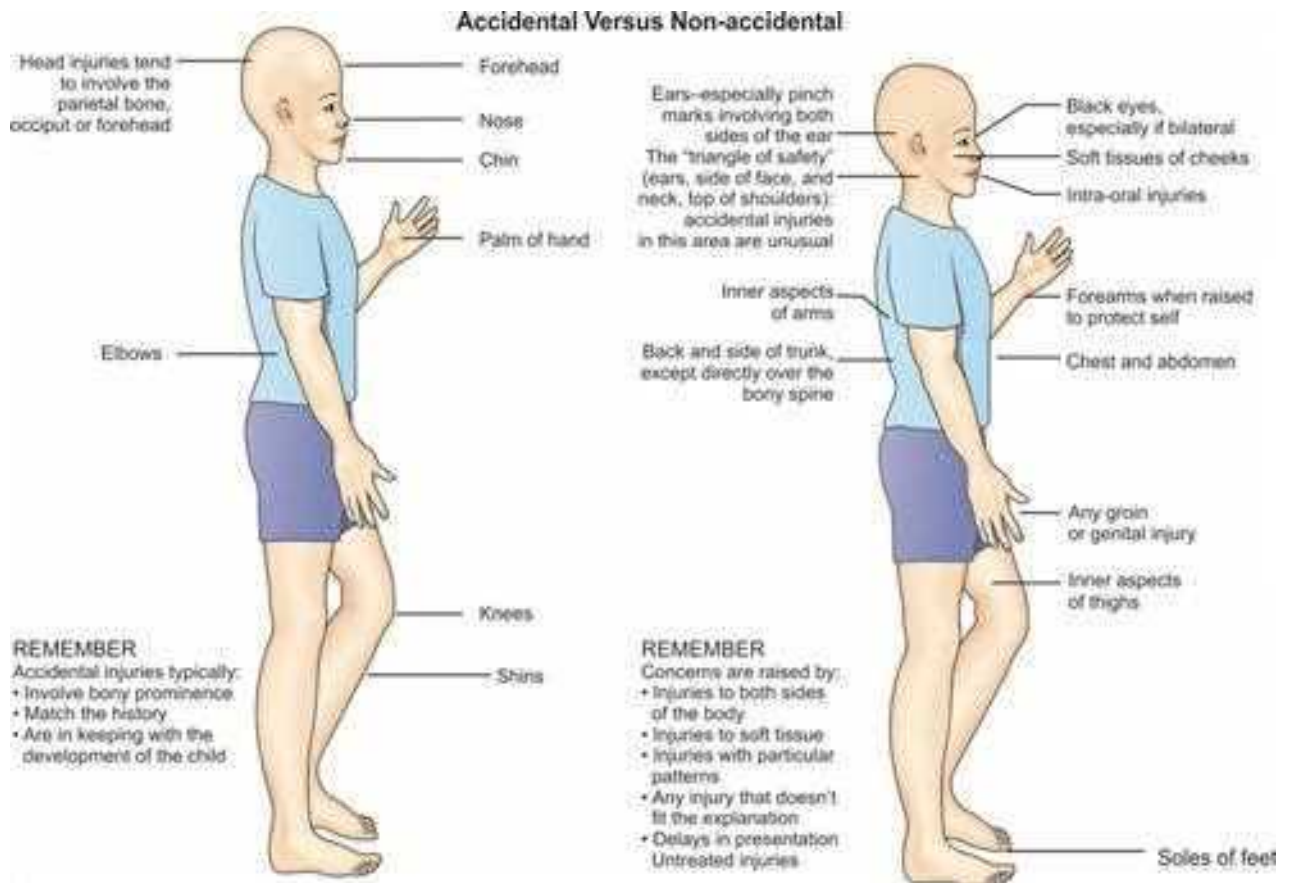


Fig. 37.7: Shows common sites of accidental versus non-accidental bruising



Figs 37.8A and B: (A) Well demarcated bruise demonstrating blunt force trauma by object. On this occasion, the buckle of a belt (B) Forced hand slap injury (or could have been face forcibly impacting on ridged object)



**Fig 37.8C:** Marks produced by forced trauma using a range of objects



**Fig. 37.8D:** Well demarcated outline left by object following forced trauma



**Figs 37.9A and B:** (A) Fingertip marks due to forceful gripping (B) Multiple unexplained bruises including finger tip bruise to soft tissue area of left cheek



**Fig. 37.10:** Recent horizontal linear bruises extending across the cheek consistent with an adult hand slap. (Source: Hobbs J, Wynne JM. Physical Signs of Child Abuse, 2001)



**Fig. 37.11:** Forced impact trauma often includes the upper aspect of the ear—this is rare in accidental trauma but is highly correlated with non-accidental trauma



**Fig. 37.12:** Adult bite marks on upper left chest of a baby. Teeth marks are also seen. Confirmed by forensic dentistry. The outline of dental arch is evident

## Fractures

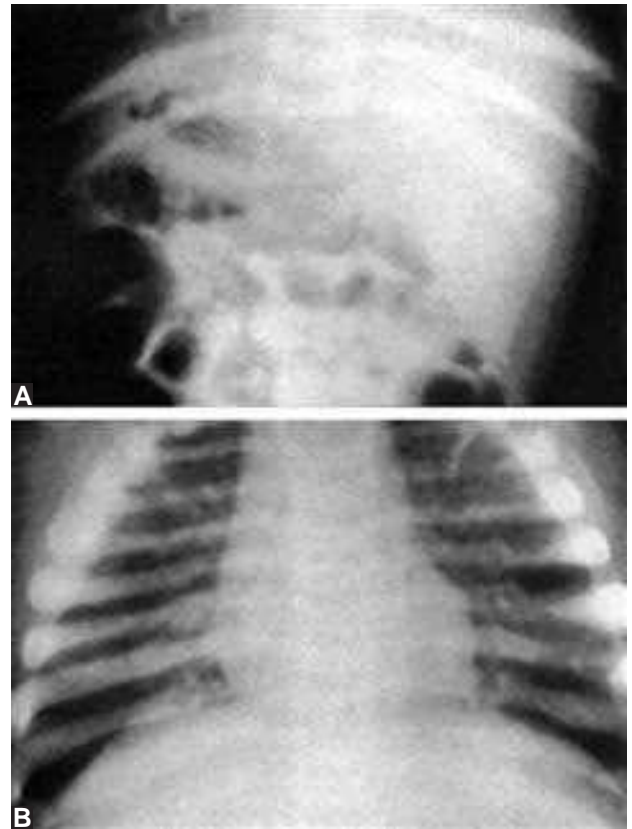
It takes considerable force to produce a fracture in a child. Any explanation must be consistent with the child's developmental age and with the type of fracture. The younger the child with the fracture the greater the likelihood of abuse. Eighty percent of abused children with fractures are less than 18 months old whereas 85% of accidental fractures occur in children over 5 years.

The following types of fracture are more suspicious of abuse in infants:

- Spiral fractures of the humerus are uncommon and strongly linked to abuse. Any humerus fracture other than a supracondylar fracture is suspicious of abuse in children. All humeral fractures in a non-mobile child are suspicious if there is no clear history of an accident.

Multiple fractures are far commoner in abused children:

- Ribs—in the absence of underlying bone disease or major trauma (such as a road traffic accident), rib fractures are highly specific for abuse and may be associated in some cases with shaking (Figs 37.13A and B). It has been suggested that rib fractures can be caused by the resuscitation process (where there has been an arrest) but posterior rib fractures have never been described following resuscitation. Anterior or costochondral rib fractures have been described extremely rarely in 0.5% in resuscitation.
- Femoral fractures in children who are not independently mobile are extremely suspicious of abuse regardless of the type. Once a child is able to walk they can sustain a spiral fracture from a fall while running, so once again it is exceptionally important that a clear history is obtained.



**Figs 37.13A and B:** Multiple rib fractures of different ages—different stages of callous formation, follow several episodes of abuse

A transverse fracture of the femur is the commonest presentation and can be found in accidental and non-accidental injuries.

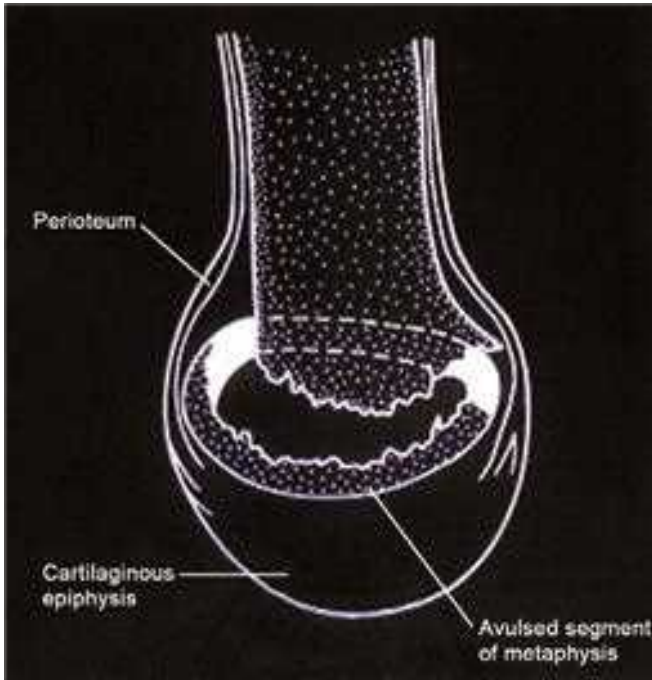
- Metaphyseal fractures—these are relatively rare fractures. In the neonatal period they can be related to birth injury, but outside the neonatal period under the age of 2 years are suggestive of abuse particularly if femoral. Epiphyseal fractures will only be found if looked for carefully and always require paediatric radiological opinion (Fig. 37.14).
- Skull fractures—a history of a fall less than 3 feet—this rarely produces a fracture.

A linear parietal fracture is the commonest fracture and can be accidental or non-accidental. It is always crucial to obtain a clearly history which has been witnessed (Fig. 37.15). Particularly concerning skull fractures are:

- Occipital fractures
- Depressed fractures
- Growing fractures
- Fractures complex or multiple in severely injured or fatally injured children. It is twice as likely to be due to abuse.



- Wide fracture (with an X-ray 3.0 mm or more)
- A fracture which has crossed the suture line or multiple or bilateral
- A fracture with associated intracranial injury
- A history of a fall less than 3 feet—this rarely produces a fracture.



**Fig. 37.14:** Metaphyseal fractures in under 2's can be identified during skeletal survey and are highly correlated with twisting/pulling type injuries in the context of abusive trauma



**Fig. 37.15:** Boggy swelling over the right parietal area. X-ray confirms parietal fracture. In this case, an inconsistent history was provided for the injury describing a 4 months infant rolling from a bed which the infant was incapable of doing

### Intra-Abdominal Injury

Intra-abdominal injury is very uncommon and, when abusive, typically occurs in young children, and under 3 years of age has a high mortality rate especially if the diagnosis is missed or delayed. Diagnosis can be difficult with delay in presentation and no history of trauma provided by the carer. There may be no signs of external injury and therefore one must have a low threshold of suspicion particularly if there are any other injuries in a child under 1 year of age. This should always include a search for internal injury.

### Thermal Injuries

Patterns that suggest abusive burn and scald injuries include:

- Glove and stocking circumferential scalds of limbs/buttocks from (forced emersion) (Fig. 37.16)
- Deep cratered circular burns, which heal to leave scars (cigarette burns) (Fig. 37.17A to C)
- Clearly outlined brand marked contact burns (hot objects—e.g. clothes, iron, fire grid, cooker/hot plate).
- Poured scald
- Friction or carpet burns (e.g. from dragging child across the floor).

Common sites for abusive burns include:

- Feet and hands, especially the backs of hands
- Buttock
- Face
- Multiple Sites.

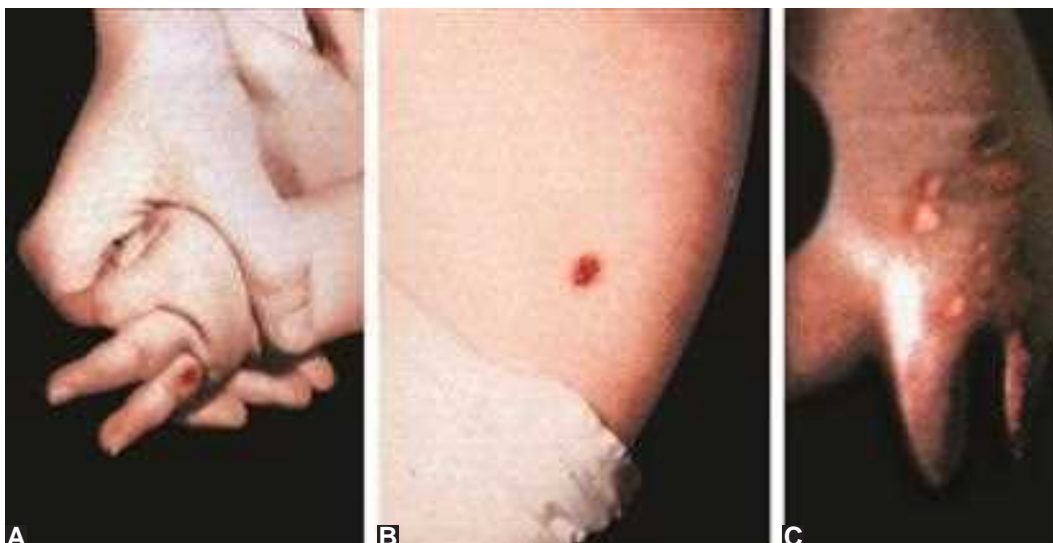
### Other Potential Non-Accidental Injuries

A variety of other injuries are encountered in abusive circumstances. These include:

- Scratches, abrasions, incised wounds.
- Mouth injuries, for example fractured teeth, lacerations and bruises to lips and tongue, torn labial frenulum in infant or toddler, palatal burns from hot food or



**Fig. 37.16:** Forced dipping of arm into hot water of a toddler



**Figs 37.17A to C:** (A) Punched out "crater-like" burn 0.8 mm–1.0 cm diameter illustrating inflicted cigarette burn. (B) Cigarette burn healing—can be confused with impetigo at this stage. (C) Full thickness cigarette burns going on to scar formation

lacerations from cutlery or objects forced into the mouth. Needles forced into skull or other tissues in context mainly of induced illness.<sup>13</sup>

*Brain injury* subsequent to trauma can be due to direct blows angular forces or due to hypoxic ischaemic injury sometimes due to shaking of the child or shaking plus impact injuries (even onto soft surfaces following, e.g. a throw). Retinal haemorrhages can also be associated commonly with inflicted brain injury (IBI) also known as non-accidental head injury involving angular forces. This can be in one or both eyes but classically involves all layers of the retina. It is important that a paediatric ophthalmologist uses indirect ophthalmoscopy to establish the findings (pictures should be taken via retcam if possible) and provide a specialist opinion in such cases. Inflicted head injury can be accompanied by other injuries on other parts of the body. Although only in approximately half of cases, a range of fractures can be found when further investigation is instigated (full skeletal survey).

## CHILD SEXUAL ABUSE

Sexual abuse happens when a child or young person under the age of 16 is used for the sexual gratification of an adult. More than 95% of cases present as historical abuse rather than acutely. Child sexual abuse (CSA) is often associated with other forms of abuse including physical abuse, emotional abuse and physical neglect.

The child sexual abuse accommodation syndrome, i.e. impact on children of sexual abuse:<sup>15</sup>

- Secrecy
- Helplessness

- Entrapment and accommodation
- Delayed, conflicted and unconvincing disclosure
- Retraction.

### *Sexual Abuse Recognition*

Recognition of sexual molestation of a child is entirely dependent on the individual's inherent willingness to entertain the possibility that the condition may exist. Unfortunately, willingness to consider the diagnosis of suspected child abuse molestation frequently seems to vary in inverse proportion to the individual's level of training.<sup>16</sup>

### *Behavioural Indicators*

None of these are pathognomonic but raise suspicion requiring further detailed enquiry and analysis:

- Regression
- Sleeping disturbances
- Eating disorders
- School problems
- Social/peer problems
- Poor self-esteem
- Sexualised behaviours.

### *Medical Indicators*

- Very few single "diagnostic" signs
- Sexually transmitted diseases
- Bloodstains on underwear
- Bruising or swelling of genital area (history important)
- Grasp marks
- Soiling enuresis

- Anogenital pain
- Various types of penile/vaginal discharge
- Hymenal/anal findings (vulvoscopy).

Further detailed information on the physical signs of child sexual abuse can be found in the RCPCH publication "The Physical Signs of Child Sexual Abuse. An evidence-based review and guidance for best practice, March 2008."

### Child Sexual Abuse Health Consequences in Adulthood

- Gastrointestinal problems such as ulcers, irritable bowel syndrome and chronic abdominal pain; pelvic pain
- Gynaecological problems
- Chronic headache
- Psychological effects
- Emotional effects
- Physical effects
- Social effects.

### Child Pornography

This refers to images or films (also known as child abuse images) and in some cases "writing" depicting sexually explicit activities involving a child. As such, child pornography is a record of child sexual abuse.

Child pornography is among the fastest growing criminal segment on the internet and producers of child pornography try to avoid prosecution by distributing their material across national borders. Pre-pubescent pornography is viewed and collected by paedophiles for a variety of purposes ranging from private sexual uses, through to trading with other paedophiles. Children of all ages, including young infants, are abused in the production of pornography. The United States Department of Justice estimates that pornographers have recorded the abuse of more than 1 million children in the United States alone. There is an increasing trend towards younger victims and greater brutality. According to the world congress against commercial sexual exploitation of children "while impossible to obtain accurate data, a perusal of the child pornography readily available in the international market indicates that a significant number of children are being sexually exploited through this medium."<sup>17</sup>

### Child Sex Tourism

One source of child pornography distributed world-wide is created by "sex tourists." Most of the victims of child sex tourism reside in developing countries. Interpol works with its 188 member countries to combat the problem.<sup>18</sup>

## FABRICATED AND INDUCED ILLNESS

Fabricated and induced illness (FII) is a form of abuse, not a medical condition. Previously known as Munchausen

syndrome by proxy, this label applies to the child, not the perpetrator. The label is used to describe a form of child abuse.

There is a spectrum of fabricated illness behaviour and FII may co-exist with other types of child abuse. The range of symptoms and systems involved is very wide and it is usually the parent or care giver who is the perpetrator. FII includes some cases of suffocation, non-accidental poisoning and sudden infant death.

### Features

- A child is presented for medical assessment and care, usually persistently, often resulting in multiple procedures.
- Mismatch or incongruity between symptoms described by parent/carer and those objectively observed by medical attendants.
- The perpetrator denies knowledge of the aetiology of the child's illness.
- Acute symptoms and signs cease when the child is separated from the perpetrator.
- Intention or non-accidental poisoning often presents with bizarre symptomatology—a range of substances are involved (e.g. methadone, salt).

Think of Fabricated and Induced Illness When:

- Inconsistent or unexplained symptoms and signs
- Poor response to treatment
- Unexplained or prolonged illness
- Different symptoms on resolution of previous ones, or over time
- Child's activities inappropriately restricted
- Parents/carers unable to be assured
- Problems only in the presence of parent/carer
- Incongruity between story and actions of parents/carers
- Erroneous or misleading information
- Family history of unexplained illness or death
- Exaggerated catastrophes or fabricated deaths.

The paediatrician is usually the professional who suspects FII. This hinges on taking very detailed histories from all adults who may have information to give, careful checking of aspects of history which can be corroborated and, if necessary, a period of admission or specific tests, constantly weighing up the balance between needing to confirm the abuse and avoiding necessary harm to the child. The production of a detailed chronology is essential in the investigation of this form of abuse.<sup>19</sup>

## CHILD TRAFFICKING

The illegal trading of people is a world-wide problem and is thought to be the third largest illegal trade after drugs and weapons trafficking. Globalisation has contributed to the growth of trafficking. The US Department of State estimates

that 800,000 people are trafficked across national borders annually, nearly 50% of these being children. That figure is considered to be a minimum with some estimates ranging up to 2 million people. There are no clear estimates about the numbers of children trafficked around the world, but UNICEF described the numbers as "enormous." Whilst in Western Europe women are the most numerous victims, globally children constitute the largest numbers.<sup>20-22</sup>

Children are often exploited in relation to:

- Child labour e.g. cannabis farms
- Debt bondage
- Domestic servitude
- Begging
- Benefit fraud
- Drug trafficking/decoys
- Illegal adoptions
- Forced/illegal marriage
- Sexual abuse.

## Recognising and Identifying Trafficked Children

### *High Level Concerns*

- Claims to have been exploited through sexual exploitation, criminality (i.e. cannabis farms, petty street crimes, begging etc.), labour exploitation, domestic servitude, forced marriage, illegal adoption and drug dealing by another person.
- Is located or recovered from a place of exploitation and/or involved in criminality that highlights the involvement of adults, e.g. is recovered from cannabis farm/factory, brothel, street crime, petty theft, pick pocketing, begging.
- Claims to be in debt bondage or "owes" money to other persons/has to pay of large debts.
- Has entered the country illegally.
- Has no passport or other means of identification.
- Has false documentation or genuine documentation that has been altered or fraudulently obtains' or the child claims that their details (name, DOB) on the documentation is incorrect.
- Claims to have been in the country for years but has not learned the local language or culture.
- Is unable to confirm the name and address of the person meeting them on arrival.
- Has had their journey or visa arranged by someone other than themselves or their family.
- Is unable, or reluctant to give details of accommodation or other personal details.
- Reports from reliable sources suggesting the likelihood of involvement in sexual exploitation.
- One among a number of unrelated children found at one address.

- Person in control of/with the child has applied for acted as guarantor for visas on behalf of others.
- Person interpreting for the child at interviews and meetings was previously known to them (i.e. not appointed or approved by authorities).

### Concerns

- On arrival in the country or when attending meetings/ interviews is accompanied by an adult who may not be legal guardian and who insists on remaining with the child at all times.
- Has a prepared story very similar to those that other children have given perhaps hinting they have been coached.
- Leaving home/care setting in clothing unusual for the individual child (inappropriate for age, borrowing clothing from older people).
- Returning after having been missing, look well cared for despite having no known base.
- In a private fostering arrangement which has not been registered or child being cared for by adult(s) who are not their parents (except those in social work care).
- Is permanently deprived of a large part of their earnings by another person/no control over earnings.
- Goes out the same hours everyday (unless legitimate, verified work).
- Works in various locations.
- Has limited freedom of movement.
- Is excessively afraid of being deported.
- Indicators of working (tired in school, condition of hands etc.).
- Does excessive housework around the house.
- Appropriate adult cannot provide photo ID.
- Involved in underage marriage.

### General Concerns

- Significantly older boyfriend/girlfriend
- Placement breakdown
- Has gone missing from local authority care
- Is registered at a number of different addresses
- Is malnourished
- Is withdrawn and refuses to talk or appears afraid to talk to a person in authority
- Exhibits self-assurance, maturity and self confident not expected to be seen in a child of such age
- Does not appear to have money but does have a mobile phone
- Has not been registered with or attended GP practice
- Has not been enrolled in school
- Truancy/disengagement with education

## Child Abuse and Neglect—How do We Protect these Children?

- Receives unexplained/unidentified phone calls whilst in placement/temporary accommodation
- Shows physical or emotional signs of physical or sexual abuse
- Has a history of missing links and unexplained moves
- Evidence of sexually transmitted infection or unwanted pregnancy
- Known to be sexually active
- Evidence of drug, alcohol or substance misuse
- Adults loitering outside the child's usual place of resident
- Accounts of social activities with no plausible explanation of the source of necessary funding
- Pattern of street homelessness
- Acquisition of money, expensive clothes, mobile phones or other possessions without plausible explanation
- Low self-image, low self-esteem, self-harming behaviour including cutting, overdosing, eating disorder, promiscuity
- Entering or leaving vehicles driven by unknown adults
- Possible inappropriate use of the internet and forming on-line relationships, particularly with adults
- Known to beg for money.<sup>23</sup>

### CHILD PROTECTION STANDARDISED PROCEDURES

Roles and responsibilities of various professionals and agencies and that everyone is clear about what everyone does in protecting a child. Where the responsibilities lie and who has responsibility to act often is not clear—so children fall through gaps with professionals thinking it is someone else's job.

Inter-agency and inter-professional case discussions or planning meetings are essential to ensure that information is shared in detail and the child is helped throughout the whole process of assessment and investigation and that they are not further traumatised throughout this time by the process itself.

Clearly standardised documentation is critical. It must be contemporaneous, i.e. written as soon as is possible on speaking with the child/family or child or with others. It is best to document everything clearly, preferably in typed reports which have adequate analysis and conclusions (Appendices 37.1 to 37.6).

### LEGAL SYSTEM

There are various legal systems throughout the World. In Scotland, the Child Protection Children's Hearing System is a "tribunal" system involving lay members of panels deciding on interventions on advice of multi-agency assessments. There is also an adversarial criminal process to decide upon

whether individuals are culpable specifically for the crime of abuse of children.

### ACKNOWLEDGEMENTS

1. Hobbs C. Physical Signs of Child Abuse. London: WB Saunders Co, Ltd; 1996.
2. Elsevier Publications.
3. Perry BD.
4. Scottish Government Department of Health.
5. RCPCH Child Companion Document, RCPCH 2006.
6. McNamee P. Personal Assistant to Dr Jean Herbison and to the staff of the Child Protection Unit, NHSGCC.

### REFERENCES

1. Scottish Executive. (2002). It's everyone's job to make sure I'm alright. [online] Available from [www.scotland.gov.uk/Publications/2002/11/15820/14009](http://www.scotland.gov.uk/Publications/2002/11/15820/14009) [Accessed November 2002].
2. Falkov. Study of Working Together 1996, Part and Report. Fatal child abuse and parental psychiatric disorder. An analysis of 100 area Child Protection Committee Case Reviews conducted under the terms of part 8 of the Working Together under Children Act 1989. London, Department of Health 1996.
3. Rederand Duncan. Adult Psychiatry—a missing link the child protection network. Comments on Falkov's Fatal child abuse and parental psychiatric disorder. *Child Abuse Review*, 1997;6:35-40.
4. Social Care Institute for Excellence (2009). SCIE Guide 30: Think child, think parent, think family: a guide to parental mental health and child welfare. [online] Available from [www.scie.org.uk/publications/guides/guide30](http://www.scie.org.uk/publications/guides/guide30).
5. Hughes H. Impact of spouse abuse on children of battered women—Violence Update. 1992;1:9-11.
6. McWilliams M, McKiernan J. Bringing it out into the open: Domestic Violence in Northern Ireland. Belfast: HMSO;1993.
7. National Children's Home. 1994. [online] Available from [www.nch.org.uk](http://www.nch.org.uk)
8. Bakken J, Miltenberger RG, Schauss S. Teaching parents with mental retardation: knowledge versus skills. *Am J Ment Retard*. 1993;97(4):405-17
9. Tymchuk AJ. Symptoms of Psychopathology in Mothers with Mental Handicap. *Mental Handicap Research*. 1993;Vol 6(1):18-35.
10. McGaw S, Newman, T. What works for Parents with learning disabilities? 2005. Ilford: Barnardo's.
11. Department of Health and Department for Education and Skills. (2007). Good Practice Guidance on Working with Parents with a learning disability. [online] Available from [www.dh.gov.uk](http://www.dh.gov.uk). [Accessed June 2007].
12. National institute for clinical excellence (NICE) Guideline. (2009). When to Suspect Child Maltreatment. [online] Available from [www.nice.org.uk](http://www.nice.org.uk). [Accessed 2009].
13. RCPCH. 2006. Child protection companion. London [online] Available from [www.core-info.cf.ac.uk](http://www.core-info.cf.ac.uk). [Accessed 2006].

14. Sugar NF, Taylor JA, Feldman KW. Bruises in infants and toddlers: Those who don't bruise rarely bruise. *Arch Paediatric Adolescent Medicine*. 1999;53:399-403.
15. Summit RC. The child sexual abuse accommodation syndrome. *Child Abuse Negl*. 1983;7(2):177-93.
16. Sgroi SM. Sexual molestation of children: The last frontier in child abuse: *Child Today*. 1975;4:18-21.
17. Healy MA. Child Pornography: An international perspective. 1996.
18. [online ] Available from [www.interpol.int/Public/Children/Default.asp](http://www.interpol.int/Public/Children/Default.asp).
19. RCPCH. (2009). Fabricated or Induced Illness by Carers (FII): A Practical Guide for Paediatricians. [online] Available from <http://www.rcpch.ac.uk/Health-Services/Child-Protection/Child-Protection-Publications>. [Accessed 2009].
20. ILO. (2002). Every Child Counts. New Global Estimates on Child Labour ILO/PEC Geneva. [online] Available from [www.ilo.org/ipeinfo/product](http://www.ilo.org/ipeinfo/product). [Accessed 2002].
21. UNICEF. (2005). Combating Child Trafficking: Handbook for Parliamentarians. [online] Available from [www.unicef.org/publications](http://www.unicef.org/publications). [Accessed March 2005].
22. United Nations Office on Drugs and Crime. (2006). Trafficking in Persons: Global Pattern. [online] Available from [www.unodc.org/documents/human-trafficking/HT/globalpatterns/en\\_pdf](http://www.unodc.org/documents/human-trafficking/HT/globalpatterns/en_pdf) [Accessed April 2006].
23. Glasgow Child Protection Committee. (2001). Glasgow Child Protection Committee Inter-agency Guidance for Child Trafficking. [online] Available from [www.glasgowchildprotection.org.uk/NR/rdonlyres/AADFD622-A183-4B96-9D5E-D6F3C2C37A79/0/GLASGOWCHILDTRAFFICKINGGUIDANCESept09.pdf](http://www.glasgowchildprotection.org.uk/NR/rdonlyres/AADFD622-A183-4B96-9D5E-D6F3C2C37A79/0/GLASGOWCHILDTRAFFICKINGGUIDANCESept09.pdf) [Accessed June 2001].

## APPENDIX 37.1

### Child Protection/Child Welfare Documentation

This divider should be inserted into the medical notes once child protection or child welfare concerns are identified and an initial telephone referral to social work has been made. (Yorkhill Child Protection Procedure and Guidance, held in blue folders on all wards or on the Yorkhill Intranet for further guidance).

This section must be retained behind the identification labels at the front of the case notes.

All staff involved in the child’s care, who have information related to the child protection concern, must use this section to keep a record of their involvement and concerns, ensuring that a chronological, complete and integrated review is possible. (There can be cross-reference to more complete entries in the medical notes or in locally held files.)

Record keeping must comply with professional standards: All information must be factual, clear, succinct, contemporaneous, dated and timed and the person completing the entry must sign the records and print their name and designation clearly.

**What to file in this section:**

#### SECTION 1

- Comprehensive Health Evaluation—this evaluation to be conducted and recorded by paediatrician at specialist registrar (SPR) grade in full collaboration with receiving consultant paediatrician/surgeon. To be signed off by consultant staff only.
- All subsequent medical notes for the child must be documented in this section (Appendix 37.2).

#### SECTION 2

- The standard operating procedure—this is for child protection and should be activated and completed during child’s stay as in-patient (Appendix 37.3).

#### SECTION 3

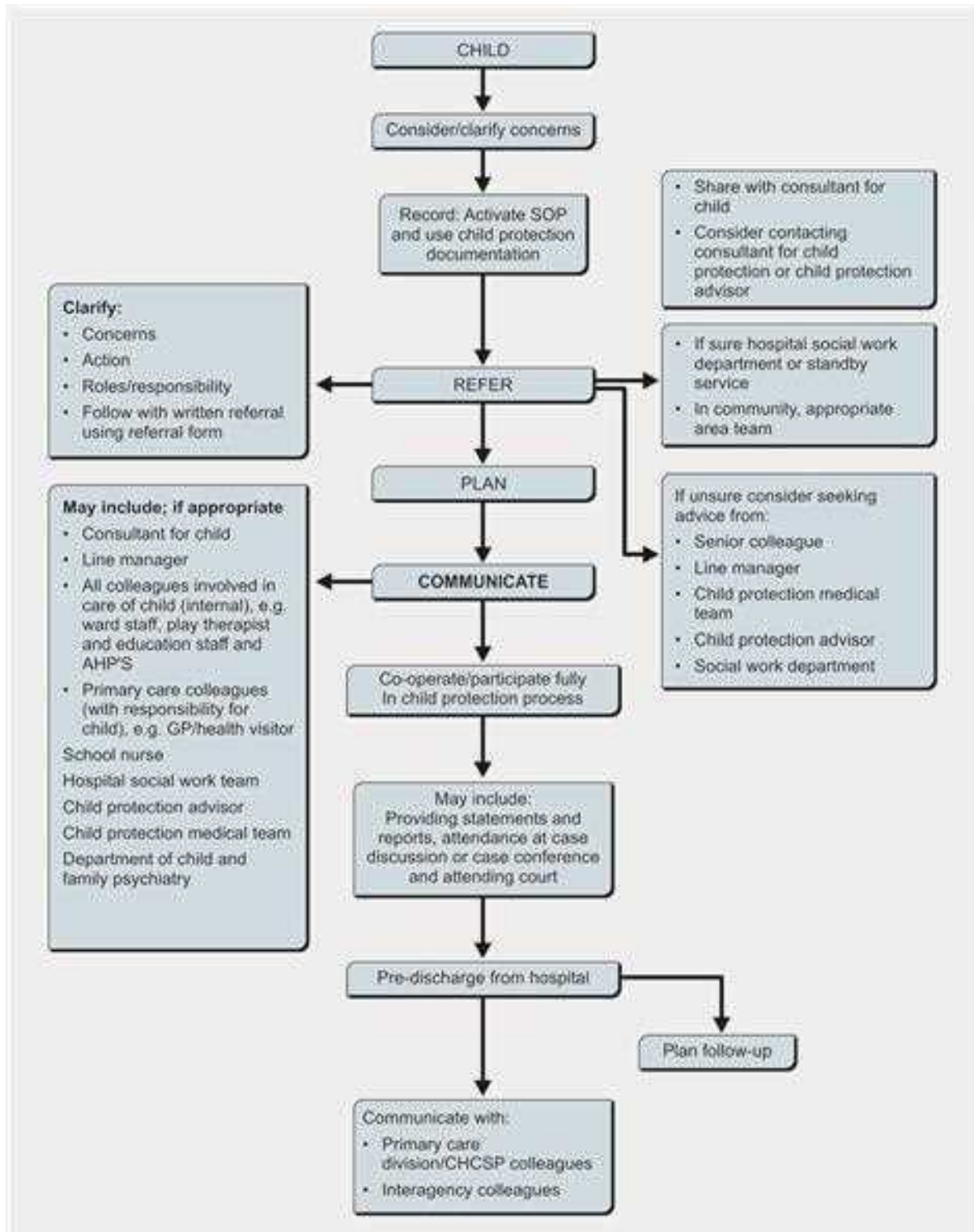
- Multi-disciplinary chronological record and continuation sheets as necessary (Appendix 37.4).
- Action plan(s) as many as necessary should be completed at point of contact or as concerns are identified (Appendix 37.5).
- Conclusion to child protection/child welfare concerns—this should be completed prior to discharge (Appendix 37.6).

The lead consultant will be responsible for maintaining an overview of this section.

Prior to discharge, agreement for the child to be discharged must be confirmed with the lead consultant and the relevant social worker in the social work department (this may be by fax) and documented in this section. Plans for the protection of the child post-discharge must also be briefly recorded together with the name and designation of the person to contact in the event of a query.

If following assessment, no child protection concerns are substantiated; this should be clearly recorded by the lead consultant and agreed by the social worker involved. However, this section is retained in the notes.

## CHILD PROTECTION PROCESS FOR ALL STAFF





## SECTION 1 Comprehensive Health Evaluation

### APPENDIX 37.2

#### Child Protection/Child Welfare Documentation Comprehensive Health Evaluation of a Child Where There are Welfare Concerns

Child's Surname		Forename(s)	
Known As		DOB	Sex:
Address			CHI No
			Postcode:
Siblings		DOB	
		DOB	
		DOB	
		DOB	
		DOB	
		DOB	
Unborn Child			
Mother Name:		Father Name:	
Address (if different)		Address (if different)	
DOB:		DOB:	
GP		Referrer	
Address		Address	
		Home Tel No:	
		Designation:	
School/Nursery Attended:		School Nurse/HV:	
Date of Examination:	Time of examination:	Emergency <input type="checkbox"/>	Planned <input type="checkbox"/>
Location of Examination:			
Paediatric Ward	<input type="checkbox"/>	Specialist CP Unit	<input type="checkbox"/>
GP Surgery	<input type="checkbox"/>	Police Medical Suite	<input type="checkbox"/>
Community Paediatric Clinic	<input type="checkbox"/>	Other (specify)	<input type="checkbox"/>

Person/s Accompanying Child _____		
Relationship to Child		
Mother in attendance?	Yes <input type="checkbox"/>	No <input type="checkbox"/>
Father in Attendance?	Yes <input type="checkbox"/>	No <input type="checkbox"/>
Consent to Health Assessment and Information Sharing (source i.e. parent, young person, person holding parental rights)		
Parent's signature: _____		
Young person's signature: _____		
Name	Relationship	Date
Witnessed By:		
Name	Position	Date
Referrer's concern: CSA <input type="checkbox"/> /Physical Injury <input type="checkbox"/> /Emotional abuse <input type="checkbox"/>		
Physical Neglect <input type="checkbox"/> /Non-organic failure to thrive <input type="checkbox"/>		

Name:	Date of birth:
Account of Circumstances leading to referral	
(a) From Referrer	
Name:	Position:
(b) From accompanying adult	
Name:	Position:
(c) From Child:	
Background Information already available from notes (e.g. previous concerns re-developmental delay, poor growth, possible episodes of NAI)	

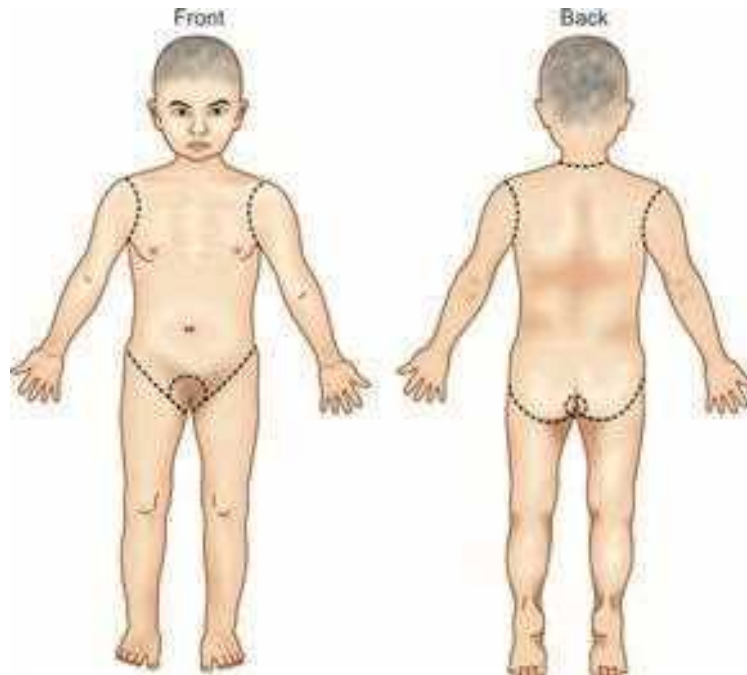
Name:	Date of birth:
<b>Concerns Raised by Child/Parent/Carer/Social Worker</b> (Tick box if problem raised and discussed)	
Illness <input type="checkbox"/>	<input type="checkbox"/> Vision <input type="checkbox"/>
Diet/Feeding <input type="checkbox"/>	<input type="checkbox"/> Child substance abuse <input type="checkbox"/>
Energy <input type="checkbox"/>	<input type="checkbox"/> Carer's Mental Health <input type="checkbox"/>
Emotional Health <input type="checkbox"/>	<input type="checkbox"/> Carer substance abuse <input type="checkbox"/>
Other (specify) _____	
Comments:	
<b>Birth Details</b>	
Antenatal Problems: Maternal drug/alcohol misuse, pregnancy induced hypertension, limited/no antenatal care.	
Hospital/Place of Birth:	
Birth Weight:	Neonatal Hearing Test: YES <input type="checkbox"/> /NO <input type="checkbox"/>
Gestation:	PASS <input type="checkbox"/> /FAIL <input type="checkbox"/>
Type of Delivery:	Guthrie: YES <input type="checkbox"/> /NO <input type="checkbox"/>
<b>Any Neonatal Problems:</b> (Give brief description, e.g. SCBU, Jaundice, drug withdrawal, etc.)	
<b>Family History</b> Include any Significant Family History	

Name:		Date of Birth:				
<b>Significant Health Problems</b> Include allergies, current medication if known, details of any pharmacy equipment required by the child e.g. nasogastric tubes, catheters.						
<b>Hospital Admissions/A&amp;E Attendances/Appointments</b> Give details if known						
<b>Child Health Surveillance</b>						
	Yes	No	Comments			
6–8 weeks	<input type="checkbox"/>	<input type="checkbox"/>				
13 months	<input type="checkbox"/>	<input type="checkbox"/>				
2 years	<input type="checkbox"/>	<input type="checkbox"/>				
3–5 years	<input type="checkbox"/>	<input type="checkbox"/>				
School Entry	<input type="checkbox"/>	<input type="checkbox"/>				
Unscheduled	<input type="checkbox"/>	<input type="checkbox"/>				
Comments:						
<b>Immunisations (Schedule requires to be kept up-to-date)</b>						
	Due	Yes			Date	No
Diphtheria, tetanus, pertussis, Hib and Polio	2, 3 and 4 months old	1	2	3		<input type="checkbox"/>
		<input type="checkbox"/>	<input type="checkbox"/>	<input type="checkbox"/>		
Meningitis C		1	2	3		<input type="checkbox"/>
		<input type="checkbox"/>	<input type="checkbox"/>	<input type="checkbox"/>		
Measles, Mumps and Rubella (German Measles) (MMR)	At around 13 months	<input type="checkbox"/>				<input type="checkbox"/>
Diphtheria, tetanus, pertussis, Hib and Polio	3–5 years (pre-school)	<input type="checkbox"/>				<input type="checkbox"/>
Measles, Mumps and Rubella (German Measles) (MMR)		<input type="checkbox"/>				<input type="checkbox"/>
Diphtheria, tetanus, pertussis, Hib and Polio	13–18 years	<input type="checkbox"/>				<input type="checkbox"/>
Other:		<input type="checkbox"/>				<input type="checkbox"/>

Name:		Date of Birth:
<b>Clinical Examination</b> General physical appearance of child (note especially any evidence of infection, neglect or injury)		
Demeanour/behaviour/impression of developmental/maturation status and emotional health		
<b>Measurements</b>		
Weight	kg	centile
Height	cm	Centile
Head circumference	cm	Centile
<b>Findings on external physical examination</b>		
	Comment	
Skin and hair		
Teeth		
Eyes		
Ears, nose and throat		
Cardiovascular system		
Blood pressure (if applicable)		
Respiratory system		
Alimentary system		
Genitalia/testes		
Nervous system		
Locomotion/posture		
a) Visual acuity	R	
	L	
b) Hearing	R	
	L	

Name:

Date of Birth:



Please indicate on the charts any areas of abrasions

Name:		Date of Birth:	
Involvement with Other Health Professionals			
	Name	Base	Next appt (if known)
Paediatrician			
S & L Therapy			
Occ. Therapy			
Physiotherapy			
CAMHs			
Other, e.g. eyes, dietician, ENT.			
CONCLUSION/OPINION			



Name:		Date of Birth:	
Summary of Findings (Please report on each item)	Mild (M) Moderate (Mod) Severe (S)	Newly identified at this assessment (tick)	Currently under treatment (tick)
Developmental delay/learning difficulties		<input type="checkbox"/>	<input type="checkbox"/>
Motor difficulties		<input type="checkbox"/>	<input type="checkbox"/>
Speech difficulties		<input type="checkbox"/>	<input type="checkbox"/>
Visual difficulties		<input type="checkbox"/>	<input type="checkbox"/>
Hearing difficulties		<input type="checkbox"/>	<input type="checkbox"/>
Missed immunisations (tick if yes)		<input type="checkbox"/>	<input type="checkbox"/>
Asthma/Allergies		<input type="checkbox"/>	<input type="checkbox"/>
Epilepsy		<input type="checkbox"/>	<input type="checkbox"/>
Growth faltering		<input type="checkbox"/>	<input type="checkbox"/>
Obesity/Overweight		<input type="checkbox"/>	<input type="checkbox"/>
Tooth decay		<input type="checkbox"/>	<input type="checkbox"/>
Mental health concerns		<input type="checkbox"/>	<input type="checkbox"/>
Substance misuse		<input type="checkbox"/>	<input type="checkbox"/>
Enuresis/Encopresis		<input type="checkbox"/>	<input type="checkbox"/>
Sexual health concerns		<input type="checkbox"/>	<input type="checkbox"/>
Other (specify)		<input type="checkbox"/>	<input type="checkbox"/>

**ACTION/CARE PLAN**

Further investigation of possible abuse requiring:

Joint Paediatric/Forensic examination	<input type="checkbox"/>	Specialist Paediatric examination	<input type="checkbox"/>
Need for further assessment/treatment of medical/developmental problems. Refer child to:			
Child development centre	<input type="checkbox"/>	GP	<input type="checkbox"/>
Community paediatrician	<input type="checkbox"/>	Ophthalmology	<input type="checkbox"/>
Audiology	<input type="checkbox"/>	Dietician	<input type="checkbox"/>
ENT	<input type="checkbox"/>	Sexual health	<input type="checkbox"/>
Speech therapy	<input type="checkbox"/>	OT	<input type="checkbox"/>
CAMHS	<input type="checkbox"/>		<input type="checkbox"/>
Physio	<input type="checkbox"/>		<input type="checkbox"/>

Other Action Required:

Refer to SWD	<input type="checkbox"/>	Refer to Reporter	<input type="checkbox"/>	Refer to Special Needs System	<input type="checkbox"/>
Signed	_____	Date	_____	Time	_____

Name in Block Letters	Designation	Review	Weeks
-----------------------	-------------	--------	-------

Copy this assessment to:

File	<input type="checkbox"/>	Police	<input type="checkbox"/>	School nurse	<input type="checkbox"/>
Parents	<input type="checkbox"/>	GP	<input type="checkbox"/>	Audit office	<input type="checkbox"/>
Social work	<input type="checkbox"/>	HV	<input type="checkbox"/>	Other	<input type="checkbox"/>
		Paediatrician	<input type="checkbox"/>	Please state	

## SECTION 2

### Standard Operating Procedure

#### STANDARD OPERATING PROCEDURE IN RELATION TO CHILD PROTECTION CONCERNS

This standard operating procedure (SOP) is in relation to the management of child protection concerns when a child is in A and E, short stay ward or an inpatient within the general wards in the Royal Hospital for Sick Children (RHSC) Glasgow, Scotland (UK). The general principles can apply to all children in all departments; however, some specialist services may require to develop further guidance.

This has been designed to equip staff with a process to follow, which will support communication both intra and inter agency inform the management of the child in relation to child protection concerns, and ensure prior to discharge, that processes are in place to protect the child. It is not a stand-alone procedure and must form part of a larger framework for all staff in relation to their child protection practice.

This SOP should be activated when child protection concerns are first identified. This may be either at the point of admission to hospital or at a later stage in the child's stay when concerns become apparent. This SOP should be activated when:

- A child is brought to hospital by the police and/or social work in relation to child protection concerns.
- A child is transferred from another hospital with identified child protection concerns.
- Another professional alerts the hospital that the child would be attending with child protection concerns.
- On admission staffs identify child protection concerns.
- As an inpatient staff identifies child protection concerns. This may be because:
  - There are concerns regarding the child
  - Behaviour of the parents
  - Other information becoming known
  - Child (or adult) discloses abuse.

#### Parents

Wherever possible we would strive to work in partnership with parents, maintaining an open and honest approach in relation to any concerns noted and subsequent actions taken. This information should be shared with parents (and child if appropriate) at the earliest opportunity. In exceptional circumstances, there would be a delay in sharing information if it was felt that to do so would place the child or staff member (s) at further risk.

Regular updates to the child, if age appropriate and the parents should be made by both social services and the child's consultant as to the progress of any child protection investigation.

Communication is a key in effective child protection work. It is essential to record fully all concerns and assessments and subsequent decisions and actions. This SOP does not replace this process but rather compliments fuller documentation in relation to child protection concerns (comprehensive health evaluation and multi-disciplinary record). When referring to social work department follow-up telephone referral using multi-agency referral form.

#### Note

The child protection unit operates monday to friday 8.30 am–5.00 pm. Child protection advisors are available within these times to offer information, advice and support in relation to child protection concerns. Tel: Child protection medical team may be contacted at any time for advice, to assist with assessment or to share the clinical management of a child where there are child protection concerns: monday to friday 9 am–5pm, Telephone: Out of hours, the on-call consultant can be obtained through hospital switchboard

In All Child Protection Cases, Social Work Must be Informed at the Earliest Point:

- If Monday–Thursday between 8.45 am and 4.45 pm and Fridays between 8.45 am and 4. Contact the hospital social work team on Telephone
- If out of hours/weekend/public holiday, contact social work standby services on Telephone
- If a child is brought in by the area social work, or area social work is investigating an incident, please inform the hospital social work team for information only
- Identify the named social worker for the child and record it in the casenote.

#### Who Can Use Standard Operating Procedure

Any member of staff can activate SOP. This would normally be following discussion with the consultant in charge of the child's care and/or the nurse in charge. The documentation will be widely available in clinical areas and thereafter kept in the child's medical case notes and reviewed on ward round. If SOP is activated, child protection documentation should also be activated to fully record issues.

**APPENDIX 37.3**

**Standard Operating Procedure for Child Protection Concerns**

<i>Inform</i>		<i>Date/Time</i>	<i>Signature/Initials</i>
Social Work Department informed.	Hospital		
	Local (please specify area team)		

If you are referring a child to social work, you should also inform—

<i>Inform</i>	<i>Date/Time</i>	<i>Signature/Initials</i>
The child’s admitting/deputising consultant (Insert name)		
The nurse in charge of the ward/department (Insert name)		
The child protection unit— (Insert name)		
The identified Liaison Health Visitor for the ward/department (Where applicable) (Insert name)		
Inform the child’s GP (Insert name)		
If the child is under 5 years, inform the child’s health visitor (Insert name)		

This second section addresses issues of the management for the child’s care—

<i>Safety</i>	<i>Yes</i>	<i>Date/Time Achieved</i>	<i>Signature/Initials</i>
Place the child’s bed in a ward where he/she can be observed by staff. (As appropriate to child’s clinical care).			
Have the child’s parents been informed (if appropriate) of the actions taken? Consideration must be given to the timing of this, and as to whether it places the child or staff in any danger—usually senior nursing/medical staff will do this.			
Where appropriate ensure staffs are aware that the child should not be removed from the ward whilst the child protection investigation is ongoing or if subject to a child protection order without discussion with senior staff and social work colleagues.			

If the child is subject to a child protection order or supervision order requirement, the following procedure must be followed–

	<i>Yes</i>	<i>Date/Time Achieved</i>	<i>Signature/ Initials</i>
Obtain a copy of the child protection order from social work and place in case notes			
Be aware of and document fully any restrictions on the family regarding contact with the child (either in the ward or in removing the child from the ward).			
Has a discussion with social work taken place as to how restrictions will be managed? And is this recorded in the child's child protection documentation?			

#### Inter-agency Collaboration and Communication

	<i>Yes</i>	<i>Date/Time Achieved</i>	<i>Signature/ Initials</i>
Are the names and telephone numbers of key personnel involved with the investigation contained within the child's notes?			
Has a case discussion/conference been arranged?			
Is there a record of the date/time/place of case discussion/conference?			
Names of ward staff attending:			
Has a written report been provided (Medical)?			
Has a written report been provided (Nursing)?			
Inform social work team if child is moving ward/department.			
Have medical staff informed social work team of results of medical investigations or change in circumstances.			
As early as possible, discussions should have taken place with social work regarding discharge arrangements in relation to the child. Have discussions taken place?			

Once the child is medically fit for discharge -

	<i>Yes</i>	<i>Date/Time</i>	<i>Signature/ Initials</i>
Ensure update from social work as to progress of the investigation prior to discharge.			
If the child is in receipt of a "Health Record booklet" ensure this is appropriately completed and returned to child/carer.			
Clarify whom the child is being discharged to. Name:  Address:  Relationship to child:			
If the child has identified health needs, does there need to be direct contact from ward to carer. Is this required?			
Ensure primary care is notified of concerns and actions. (This may differ from the family GP/HV if child is being discharged to other care). Have primary care been informed. Carers GP Name: Carers GP Address:			
If unable to identify relevant primary care practitioners (GP/HV) contact child protection advisor within Child Protection Unit. Tel: -			
If arranging nursing follow on, inform community nurses of the child protection concerns and actions.			
Has case discussion/conference taken place/been arranged?  Date: Time: Place:			
Staff members identified to attend: Names:			
If child is going into foster care, please notify looked after and accommodated children health team.  Contact details:			



APPENDIX 37.5

Child Protection/Child Welfare Action Plan

The action plan will be completed by key health professionals and placed into the child protection/child welfare section of the child’s medical notes.

Childs Name:		
Hospital Number:		
Allocated Social Worker:		Date:
Base:	Tel:	Fax:

Key Points/Issues:

Action Plan:

Lead Consultant/delegated doctor:

Print Name:

Signed:

Date:

Senior Nurse:

Print Name:

Signed:

Date:

Social Worker:

Print Name:

Signed:

Date:

## APPENDIX 37.6

**Conclusion to Child Protection/Child Welfare Concerns**

This form to be jointly completed by social worker and lead consultant in all cases where a child about whom there has been child protection concerns is being discharged where child protection concerns have been investigated and no longer remain. In these circumstances, both the social worker and the lead consultant must be satisfied that the child will be protected or is no longer in need of protection.

Child's Name: \_\_\_\_\_ Ward: \_\_\_\_\_

Hosp. No: \_\_\_\_\_ Date: \_\_\_\_\_

DOB: \_\_\_\_\_

Please Tick as Appropriate:

Child is being discharged with child protection plan in place.

Please give brief details of plan and local contact number (e.g. follow-up by child's local authority):

Child Protection concerns have been investigated and no longer remain:

Please give brief details:

Social Worker:

Print Name: \_\_\_\_\_

Signed: \_\_\_\_\_

Date: \_\_\_\_\_

Social Work Manager:

Print Name: \_\_\_\_\_

Signed: \_\_\_\_\_

Date: \_\_\_\_\_

Lead Consultant:

Print Name: \_\_\_\_\_

Signed: \_\_\_\_\_

Date: \_\_\_\_\_

A copy of this form to be kept on both the medical notes and in the child's social work file. If further concerns arise in the future, please contact the social work department and refer the case using the multi-agency child protection referral form.



# Practical Paediatric Procedures

# 38

## INTRODUCTION

Success and confidence in the skilled performance of practical procedures come from frequent repetition. These are best learned by demonstration followed by practice under supervision. This chapter gives practical details which may reduce the period of learning and increase the chances of success. The chapter has been divided into two sections: (1) routine practical procedures and (2) other practical procedures.

## PREPARATION FOR PRACTICAL PROCEDURES

Before performing any procedure on a child it is essential to obtain consent from the child's parents or guardians. Older children who are deemed competent may give their own consent. Consent should be fully informed allowing time for questioning and be obtained by the person performing the procedure. The only exception to this is in the life-threatening emergency situation if a parent or guardian is unable to be contacted in time. In this situation, it is justifiable to offer immediate life-saving treatment whilst attempts are made to contact the parents.

Performing practical procedures in children can be challenging. It is essential that the operator safely carry out the procedure without causing injury to the child or staff members. The child may be frightened or in pain and will often resist any attempts at even relatively simple procedures making the process potentially difficult and hazardous. It is, therefore, important to recognise that whilst performing any procedure a balance must be struck between the necessity to carry out the procedure versus the risk of distressing or injuring the child.

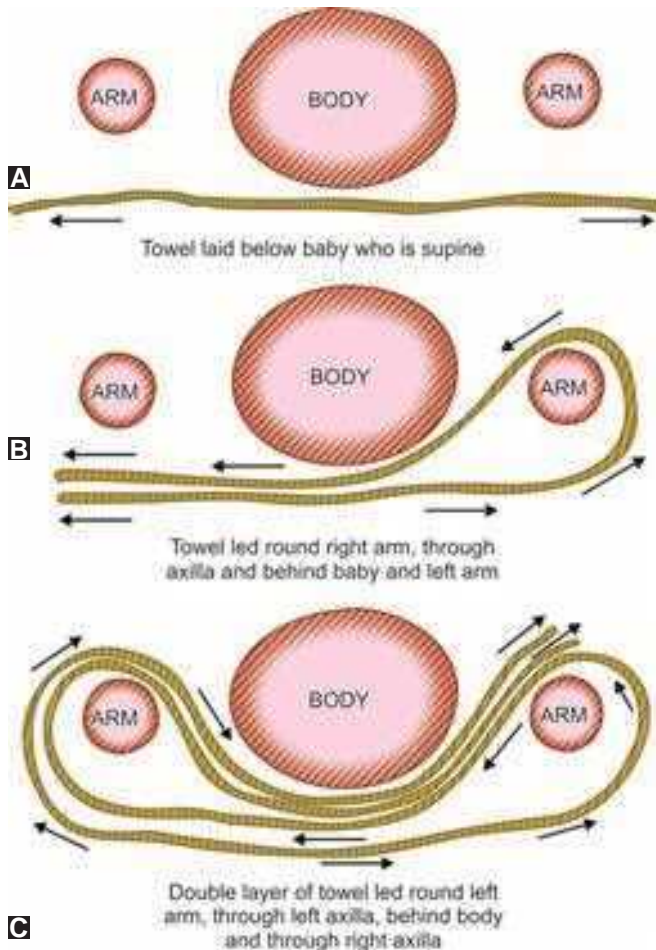
Simple techniques are often successful at reducing the child's anxiety and thus facilitating any procedure. Parents should usually be encouraged to remain as their presence frequently reduces any distress felt by the child.

Distraction methods can be used with toys or visual/auditory stimulation such as lights, gentle music or blowing bubbles. The involvement of a play specialist can be very helpful depending on the situation. The use of a dummy to promote non-nutritive sucking can help calm infants. Procedures should usually be performed in a fully equipped specialised area that allows privacy and minimises excessive noise and interruptions. Staff members present should be kept to a safe minimum.

## RESTRAINT

When considering physical restraint of children to facilitate practical procedures consideration must be given at all times to the risks versus benefits experienced by the child. Gentle protective physical containment to allow quick, simple procedures may be acceptable when balanced against the risks of sedation. Examples of this are venous cannulation and lumbar puncture (LP) in acutely unwell children when a combination of simple techniques as described above combined with gentle restraint may reduce or negate the need for sedation. Procedures that potentially take longer or are more painful require more formal sedation or anaesthesia as the potential distress experienced by the child outweighs the risks of sedation or anaesthesia when performed properly. Forcible restraint is never acceptable.

Providing gentle protective physical containment is often best achieved by the child's parent firmly but gently holding the child. This can be achieved with the child sitting on the parent's lap, facing the parent with the child's arms protruding under the parent's axillae and being gently cuddled by the parent. This allows the operator access to the child's arms and legs for procedures such as venepuncture or venous cannulation whilst the child is comforted by their parent. Some children prefer to sit facing forward and observe the procedure themselves, whilst being held by their parent, as not being able to see what is happening to them may in



**Figs 38.1A to C:** Restraining a baby

itself be anxiety provoking. Light straps to protect children from hurting themselves are also acceptable for very brief procedures where it is deemed sedation is not necessarily required and a description follows:

With a towel or sheet and a capable nurse an infant's arms may be restrained so that the head, neck or the femoral area can be safely and easily acupunctured (Figs 38.1A and C). A rectangular sheet is spread out on the table with the short edges of the sheet to the left and right of the nurse. The infant is laid in the centre of the sheet at right angles to its long axis, with feet pointing to the nurse and only the head and neck projecting beyond the upper border of the sheet. The nurse then straightens the infant's right arm adducted beside his trunk and folds the sheet on that side so that the short edge passes in front of the right arm, down through the right axilla and across behind his back. This end of the sheet is then pulled tightly so that its short border is close to the short border on the infant's left hand side with the upper corner level with the infant's shoulders. This holds the adducted right arm close against the chest. The procedure

is then repeated for the left arm, using the double layer of sheet which now lies on the infant's left side. Finally it is important to pull the two upper corners, which have been passed behind the back, firmly up through the right axilla. For further control, a second sheet can be wrapped round the infant's legs. This method of restraint will sometimes permit the paediatrician to perform practical procedures single-handed, very much a second best choice.

## SEDATION AND ANALGESIA FOR CLINICAL PROCEDURES

The child's anxiety about a clinical procedure to be carried out can be minimised by administering a sedative drug for its anxiolytic and amnesic effect. For a painful procedure, the sedative should be given with an appropriate analgesic such as a local anaesthetic (given topically by infiltration or as a nerve block as appropriate) or non-opiate or opiate analgesic.

### Sedation

The purpose of sedation is to induce a transient state of minimal or moderate drug-induced depression of consciousness in the child whilst the child still responds purposefully to verbal commands or gentle tactile stimulation and maintains a patent airway, spontaneous ventilation and normal cardiovascular function. Levels of depression of consciousness beyond this should be considered as general anaesthesia and require the presence of a fully-trained anaesthetist. Procedures lasting more than 45 minutes should also be considered for general anaesthesia. Extensive guidelines for the safe sedation of children exist and are referred at the end of this chapter.

Sedation may be unnecessary for brief practical procedures in young infants. The use of sweet oral solutions of sucrose administered prior to painful procedures has been demonstrated to have a powerful analgesic and calming effect in infants and when combined with other simple measures such as a soothing voice and dummy may pacify an infant for short periods. Sucrose oral solution (approximately 0.25 ml of 33% solution) should be administered 2 minutes before a painful procedure and can be repeated up to a total of 2 ml during the procedure. Sucrose is only effective when given orally and has no effect when given via a gastric tube.

Sedative drugs can at times produce unexpected or unwanted effects, particularly excessive sedation and respiratory compromise from either airway obstruction or hypoventilation. At times a paradoxical hyper-excitability state may arise rather than the desired sedative effect. As such the administration of sedative drugs should be taken seriously and the person administering the drug be prepared to deal with any potential side effects as they arise.

- **Patient selection:** High-risk patients who require sedation should be referred to a fully trained anaesthetist. Such patients include patients with potential difficult airways (e.g. Pierre Robin syndrome, Treacher Collins syndrome), children at risk of hypoventilation (e.g. children with obstructive sleep apnoea, neuromuscular disorders) and patients with respiratory or cardiovascular compromise (e.g. bronchospasm, cardiomyopathy, significant congenital heart disease). Younger children and infants have a higher risk of complications, particularly those under 1 year, and consideration should be given to the appropriateness of sedation in all children under 5 years of age.
- **Patient preparation:** Due to the risk of excessive sedation and possible aspiration children should be fasted prior to the administration of sedative drugs (6 hours for solids or bottle milk, 4 hours for breast milk, 2 hours for clear fluids) unless nitrous oxide (N<sub>2</sub>O) is the only sedative used when 2 hours is acceptable.
- **Environment preparation:** Sedation should be performed in an area fully equipped for all resuscitation scenarios. This should include immediate access to oxygen (O<sub>2</sub>), airway adjuncts, bag/mask ventilation, intubation equipment and a defibrillator.
- **Monitoring preparation:** Patients undergoing sedation should be monitored using a chart documenting level of consciousness, heart rate, respiratory rate, blood pressure and colour. Infants should have their temperature monitored. The patient should have a pulse oximeter and ECG monitor attached to them.
- **Staffing preparation:** At least two staff are required to be present at all times. One staff member must be responsible for administering the sedative and monitoring the patient solely (that is not performing the procedure as well).

The following are appropriate sedative drugs:

- **Nitrous oxide (inhaled gas):** Self-administration using a demand valve may be used in children who are able to self-regulate their intake (usually over 5 years of age). Usual dose 50% N<sub>2</sub>O/50% O<sub>2</sub>. Maximum dose 70% N<sub>2</sub>O, 30% O<sub>2</sub>. Rapid onset/offset with full recovery in 5 minutes. Contraindicated in pneumothorax, bowel obstruction and intracranial air (skull fractures) as may diffuse into air pockets causing them to expand.
- **Midazolam (oral/buccal or IV):** Oral (0.5 mg/kg) maximum effect in 15–60 minutes but absorption may be erratic. IV (0.1–0.15 mg/kg) maximum effect in 1–5 minutes. Major risk of respiratory depression and occasionally cardiac depression. May paradoxically cause agitation.

- **Chloral hydrate (oral):** Unpredictable absorption. May cause hyperactivity. Dose 10–50 mg/kg.

Multiple sedative drugs should not be used in the same patient as they may cause potent respiratory or cardiovascular compromise.

## Analgesia

**Local anaesthesia:** Topical anaesthesia is available in the form of a lidocaine 2.5%/pilocarpine 2.5% cream (EMLA, Astra Zeneca pharmaceuticals Ltd), which is applied to a small area of skin 1 hour before the procedure under occlusive dressing. It is not recommended for preterm neonates. The area is then cleaned with alcohol and a needle can then puncture the skin painlessly. This method is especially suitable for recurrent procedures. An alternative is amethocaine gel (Ametop) which appears to be equally efficacious but has a slightly faster onset of action (30 minutes). Both are suitable for venepuncture and LP analgesia.

The most common type of local anaesthesia used for local infiltration is lidocaine which is manufactured in 0.5%, 1% and 2% strengths. The dose is calculated on the bases of the patient's age and weight. The two best methods of infiltration or administration of local anaesthesia is either a field block or a regional nerve block. There is also a lidocaine and adrenaline mixture which can be used as a local agent with the adrenaline, a local vasoconstrictor helping to maintain a longer lasting effect of the anaesthesia and to decrease capillary bleeding. This should never be used in areas supplied by end-arteries, e.g. digits, ears, nose, penis, etc. where it can cause ischaemia.

**Non-opiate analgesics:** Paracetamol and non-steroidal inflammatory drugs (e.g. ibuprofen) are useful analgesics but tend to have slow onset of action and are, therefore, not particularly useful for procedural analgesia although provide good ongoing post-procedure analgesia. For the use of sucrose in infants see earlier.

**Opiate analgesics:** Intravenous morphine is the standard opiate analgesic of choice for severe pain. The dose is 100–200 µg/kg (max 10 mg) and subsequent doses can be titrated to effect. Intranasal diamorphine is also being increasingly used (0.1 mg/kg) as a single dose. Fentanyl and remifentanyl should not be used by non-anaesthetists. Opiates should not be used for sedation unless an analgesic effect is also required. The combination of sedative drugs and opiates can lead to profound respiratory depression and immediate access to naloxone should be available.

For very painful, frightening or multiple procedures general anaesthesia may be necessary. For the administration of a general anaesthetic, a trained paediatric anaesthetist should be present.

**Key Learning Point**

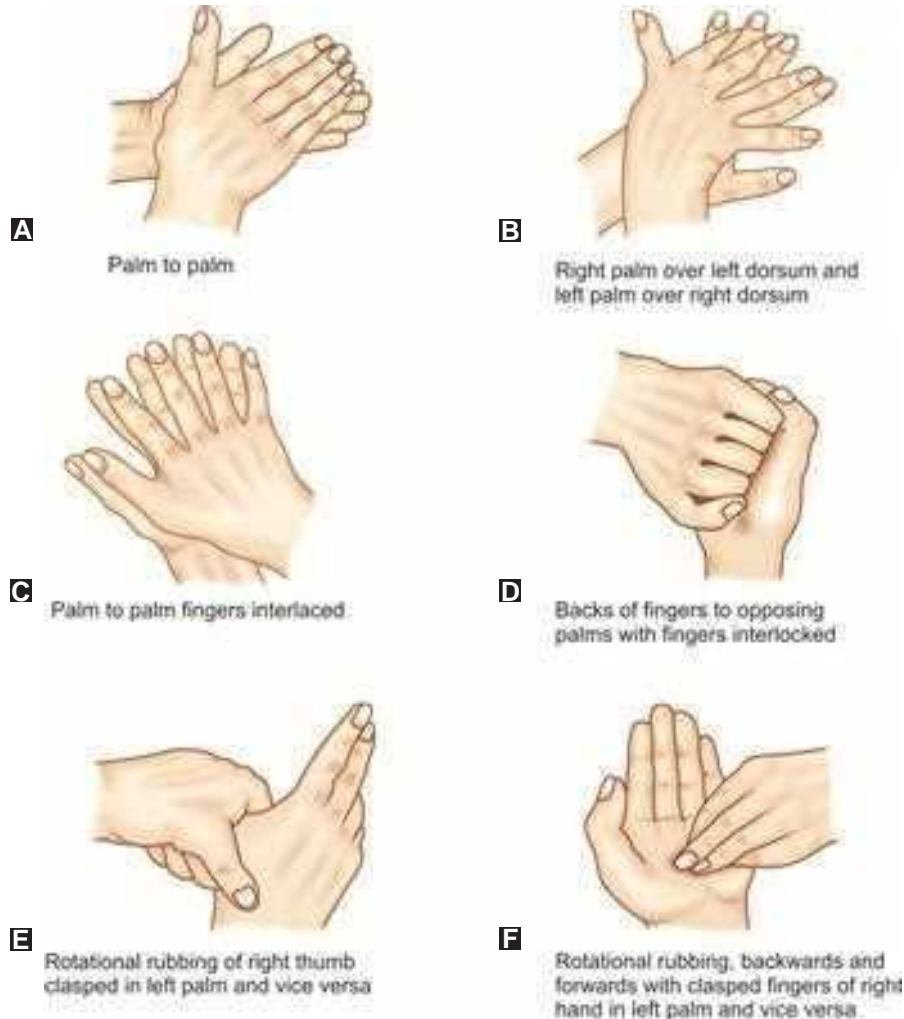
→ The child under sedation for clinical procedure should be monitored carefully as soon as the sedative is given until recovery after the procedure; concomitant use of sedatives potentiates the central nervous system (CNS) depressant effects of analgesics.

**ROUTINE PRACTICAL PROCEDURES****Handwashing**

Infection control is an important service within any health care system in any part of the world. As a health care worker you will be expected to act in a manner that ensures the safety of you, your work colleagues, visitors, parents and most importantly, the vulnerable patients we care for.

**Hand Hygiene**

- Why decontaminate your hands?  
Hand hygiene is the single most important procedure for the prevention of health care associated infection. The principles of hand hygiene reduce the levels of transient and resident organisms on the hands. Handwashing is a process that removes dirt and potentially pathogenic organisms from hands. When hands are visibly clean, the use of alcohol hand sanitising products can be used (Figs 38.2A to F).
- When to perform hand hygiene?  
Choosing the right time to decontaminate your hands is very important and should be based on the potential level of contamination. As a basic rule, hands should be decontaminated:
  - On entering and before leaving the work area



**Figs 38.2A to F:** Effective handwashing

**Table 38.1:** Hand hygiene summary

Hand hygiene procedure	Products	Duration of technique	Clinical procedures
Social hand hygiene	Plain soap and running water	15 seconds	Non-clinical procedures
	Or Alcohol hand sanitiser (visibly clean hands only)		Handling or eating food After a visit to the toilet
Antiseptic hand hygiene	Antibacterial soap	15–30 seconds	Before and after aseptic procedures
	Or Plain liquid soap to wash, followed by an application of alcohol hand rub/gel		Following microbial contamination of hands Care of patient in source or protective isolation
Surgical scrub	Antibacterial soap Or Plain liquid soap to wash, followed by an application of alcohol hand rub/gel	2–5 minutes	Before surgical interventions

Before and after:

- Patient contact
- Contact with body fluids, your own or patients'
- Wearing gloves
- Isolation nursing
- Food handling
- Invasive procedures
- Contact with contamination sources
- Caring for susceptible/high-risk patients

### Hand Hygiene Products

There are many hand hygiene products available for health care staff. It is important to choose the correct product at the appropriate time (Table 38.1).

### Types of Hand Wash

- Social hand wash: 10–15 seconds
- Hygienic/antiseptic hand disinfection: 15–30 seconds
- Surgical scrub: 2–5 minutes

### Points to Consider

- Wet hands before applying liquid soap
- Work up a soapy lather at start of technique
- Cover all areas of hands, including backs of hands, finger tips and between fingers

- Do not wear nail varnish, artificial nails or extensions
- Keep nail tips short and clean
- Remove stoned rings and wrist items before procedure
- Cover all cuts and abrasions with water-proof dressings

### Blood Sampling

Blood sampling or venepuncture is a frequently carried out procedure of entering a vein with a needle, usually to obtain a sample of blood.

### Equipment Required

- Tourniquet
- Vacutainer and double ended needle or needle and syringe
- Alcohol swabs or chlorhexidine/alcohol
- Cotton wool
- Micropore or plaster
- Collection of tubes
- Re-sheathing device
- Kidney dish
- Sharps container
- Gloves
- Relevant forms.

### Method

Welcome patient, check identity and explain procedure (if child, earlier use of EMLA/Ametop cream may be required).

Identify tests required and associated requirements, e.g. fasting status, timing of medication.

Select correct tubes and forms; fill in form accurately and clearly. Remember a group and save or crossmatch sample must be handwritten rather than using an addressograph label.

1. Support patient's arm comfortably
2. Select a vein
3. Prepare needle holder and needle out of sight of child
4. Apply tourniquet or ask member of staff to apply pressure to arm
5. Put on gloves
6. Cleanse skin
7. Steady vein with left hand and palpate above point of entry as guide. Insert needle under skin-keeping angle low and bevelled edge uppermost
8. Attach vacuum tube and advance needle into vein. Wait for tube to fill up and change to next tube, as necessary
9. Release tourniquet before removing final tube, cover needle site with swab and remove needle, apply gentle pressure
10. Discard needle holder and attached needle in a sharps bin. Do not re-sheath

11. Ask patient or parent to apply pressure, while labelling tubes and completing forms
12. Check puncture site and apply dressing. Check patient has no allergies prior to applying dressing.

## Collection of Blood Samples

### *Capillary Sampling*

Improved techniques of microanalysis allow many investigations on blood to be carried out on capillary samples. A drop of capillary blood contains at least 50 microlitres. A heel is the most useful source in the newborn whereas in older infants and children a digit is satisfactory. If the heel is used it is important to lance the fleshy side of the heel rather than the midline as midline puncture may damage the calcaneum and lead to osteomyelitis. The ear lobe is said to be less painful and flow can be speeded and "arterialised" by rubbing alcohol on the skin. The skin should be warm. The cleaned skin is pricked with a cutting stylet. A single vertical prick may produce a good flow in a child but to obtain a large volume from a neonate a slit should be cut in the heel a few millimetres in length. The cut need not be deep. This method is valuable when repeated capillary samples are required over a short period when only an initial cut is required. Further bleeding is stimulated at intervals by cleaning away the clot. A disadvantage of capillary sampling is that haemolysis of some degree is likely. This can be reduced by ensuring a fast flow and using siliconised tubes. Frothing or drying of the sample is potent causes of haemolysis. For certain investigations the capillary blood can conveniently be taken directly into glass capillary tubes (e.g. for gas analysis) or spotted onto special filter papers (e.g. for chromatography).

### **Venepuncture**

Sampling is always more successful if a good fit between syringe and needle is ensured before puncture and if blood is withdrawn slowly with moderate suction.

### *Superficial Veins*

The puncture of superficial veins is the safest type of venepuncture. No complications are to be expected if the skin is cleaned and pressure applied to ensure haemostasis. Any visible vein in the back of the hand, the dorsum of the foot, the antecubital fossa, or the scalp may be used. Scalp vein sets (21, 23 or 25 gauge) are often used.

### *External Jugular Vein*

A superficial vein often visible in the infant is the external jugular. It is often reserved for when attempts at all other veins have failed and capillary blood sampling is inappropriate.

The operator sits at the baby's head and rotates it through 90 degrees and extends the neck where it is maintained by the assistant. The external jugular vein can then be seen crossing the sternomastoid muscle and it is punctured at this point. Puncture is easier when the infant distends the vein by crying, as is not uncommon. Care should be taken not to allow air to enter these veins. Sometimes the shaft of the needle has to be carefully bent to an angle from its butt to allow easy access for the syringe and needle. Sterile care and gentle handling are required to keep the needle safe.

### *Femoral Vein*

The hips are fully abducted and the knees flexed to 90 degrees are held onto the table surface by the nurse. The femoral artery pulse is palpated and the femoral vein entered just medially to this in the inguinal crease. The needle should enter the skin at 45 degrees. Blood is often more easily obtained when the needle is withdrawn whilst gently aspirating. A needle finer than 21 gauge might be ineffective. It is easy to produce a haematoma and transient cyanosis of the leg if the adjacent artery is accidentally punctured. Application of firm pressure for at least 2 minutes after venepuncture is, therefore, an important precaution. Rare complications include spasm of femoral artery with ischaemia of the foot, infected haematoma, and osteitis of the femur and arthritis of the hip. If the artery is accidentally punctured pressure should be maintained for 5 minutes or longer if blood continues to ooze from the puncture site.

### *Fontanelle Tap (Sagittal Sinus-Tap)*

Fontanelle puncture and aspiration of blood is not routinely recommended due to the risk of complications. It may be used, however, in the emergency setting when other attempts at venous access have proven unsuccessful. The sagittal sinus is easily punctured in any infant whose anterior fontanelle is still patent. The anterior fontanelle may not close until well past the age of 18 months, although this delay can also occur in hypothyroidism, rickets, hydrocephalus and even in some healthy children. The infant is held in the supine position, the occiput just inside the edge of the table and the face pointed to the ceiling held firmly by the nurse's thumbs against his temples. The operator sits facing the top of the head and cleans the area around the proposed puncture with iodine or alcoholic chlorhexidine. An especially hairy head may mandate local shaving. The site of entry of the needle is the posterior angle of the anterior fontanelle in the midline (either at right angles to the scalp in all directions or angled backwards toward the occiput but in the sagittal plane) to a depth of approximately 2 mm. Steadying the hand on the scalp and the needle against the forefinger of the other hand makes it less easy for the point to penetrate too deeply

from the initial force necessary to pierce the scalp. A brief resistance is felt as the fontanelle is penetrated and blood is freely aspirated if positioning is correct. It is easy to go too deep if the hand does not steady the needle. As soon as the needle has been removed the child is sat up and pressure applied to the puncture site with a swab. When crying stops, the pressure in the sinus is no longer great enough to cause bleeding and haemostasis results.

It is important that the head is held firmly throughout. If the operator misjudges the position of the sagittal sinus cerebrospinal fluid (CSF) may be aspirated from the adjacent subarachnoid space. Occasionally CSF leakage may follow causing oedema of the scalp. If the needle is inserted too deeply it will enter the brain with the small but potentially important risk of local bleeding. Sagittal sinus thrombosis is a serious possible complication of fontanelle puncture. It is, however, often more likely to be a consequence of underlying disturbance (such as severe dehydration) than the needling. Inability of skilled hands to obtain blood by this route from an ill dehydrated baby suggests that thrombosis of the sinus has already occurred.

### *Repeated Venous Sampling*

When serial samples of venous blood are required (as in “tolerance” tests) only one venepuncture is essential and specimens may be obtained at regular timed intervals. Patients tolerate this procedure well and it is less painful than repeated capillary stabs. Heparin is diluted to 100 units per ml saline. A syringe is attached to a scalp vein needle set and the system filled with heparinised saline. The needle is inserted into a convenient superficial vein (not the sagittal sinus) and the needle and a loop of cannula taped to the skin in the usual manner. When a blood sample is required 0.3 ml of solution filling the dead space in the scalp vein set is withdrawn into the syringe containing heparinised saline. A second syringe is then used to aspirate the blood for analysis and the scalp vein set again filled with 0.3 ml of the dilute heparin. Multiple samples may be obtained for periods of more than 1 hour. The technique may be used in patients of any age.

It must be remembered that the blood samples obtained by this method are inevitably heparinised and are a source of plasma and not serum. It is desirable to ascertain the volume of the scalp vein set in advance so that the injected heparin solution just reaches the tip of the needle. This prevents clotting and ensures that the small infant is not heparinised.

### **Blood Culture**

Blood culture is so important in paediatric practice that a short account is included. At any age blood culture is only justifiable if carried out with rigorous precautions against

contamination and under optimal conditions for harvesting the offending organism.

Employ at least two culture bottles containing different media from your laboratory. The risk of contamination is increased if blood is not drawn cleanly on the first insertion of the needle. The skin is first cleansed with iodine in spirit. An alternative that may reduce the risk of contamination further is 2% chlorhexide in 70% ethanol solution. The cap of each of the culture bottles is also wiped with 2% iodine in 70% ethanol solution. The iodine or chlorhexidine on both skin and bottle caps is allowed to dry. With the infant suitably held the chosen vein is punctured through the iodine stained skin. The needle should either be sterile and disposable or autoclaved. The shaft must not come in contact with the finger before introduction into the vein. After the sample is obtained the original needle is removed from the syringe and a second needle is used to inject the blood into the culture bottles. The iodine or chlorhexidine should be washed from the infant’s skin with 70% alcohol. The blood culture bottles are immediately placed in the incubator. Further processing is handled by the microbiologist.

### **Measurement of Blood Pressure**

Measurement of blood pressure is an important part of routine clinical examination. Pressure is taken in one limb only (the right arm) but if coarctation of the aorta is suspected the pressure in both upper limbs and one lower limb is measured.

### *Sphygmomanometry*

In the older infant and child satisfactory assessment of the blood pressure may be obtained using the auscultatory method of sphygmomanometry. The patient should lie in the supine position with the head resting comfortably on a pillow. The arm should be free of restrictive clothing or even better, undressed. A sphygmomanometer cuff suitable to the size of the child’s arm should be chosen, the breadth of the cuff being about two-thirds of the length of the upper arm, too large a cuff cannot be smoothly applied to the limb and overlap interferes with adequate auscultation. Too small a cuff results in artificially and often strikingly—high—pressures. The cuff is applied so that the inflatable inner bag is centred over the medial aspect of the arm where it will compress the brachial artery and wrapped firmly but not tightly round the arm. There should be no folds or wrinkles.

Sit comfortably beside the patient and palpate the radial pulse while inflating the cuff. The point of disappearance of the radial pulse gives an indication of the level of the systolic blood pressure. The cuff is inflated a further 30–40 mm Hg and a stethoscope applied over the brachial artery in the cubital fossa. The cuff is slowly and steadily deflated whilst systolic and diastolic pressure points are auscultated.

If lying and standing measurements are required as when assessing the effect of hypotensive agents it is easier to measure the pressure in the arm in the supine position first and then allow the child to stand with the cuff still in position. The blood pressure in the leg is taken in a similar fashion except that the child lies comfortably prone with head turned to one side or supine with the knee slightly flexed. The cuff is applied to the thigh and again should be of a size that covers two-thirds of the length; auscultation is made over the popliteal artery in the popliteal fossa.

For the blood pressure measurement so obtained to be at all accurate the child should be co-operative and at ease. If he is crying or restless then the record will obviously be worthless although it is often useful to apply the cuff and go through the motions in the hope that future attempts may be accepted with less apprehension. It is useful to place the manometer in such a position that the patient may watch the rise and fall of the mercury column (without raising his head!) since this may gain his quiet interest.

### *The Flush Technique*

Difficulty in auscultating the artery and in obtaining the required degree of co-operation often makes the sphygmomanometer method impracticable in the infant. A suitable alternative is the 'flush technique' which allows reasonably accurate determination of a single blood pressure point considered to be somewhere between systolic and diastolic levels. The advantages of this technique are that it requires minimal equipment and can be performed in a noisy environment. The main disadvantage is that the measurement is often only a crude estimate of the mean blood pressure.

The equipment is the standard mercury manometer, a small cuff (to cover at least two-thirds of the upper part of the appropriate limb), a length of thin rubber bandage about 2.5 cm broad, a pacifier or feeding bottle to keep the infant quiet, and two observers, e.g. doctor and nurse. The infant should be placed unclothed, supine on a comfortable flat surface in a warm, well-lit room. The sphygmomanometer cuff is applied firmly in the normal manner on the upper arm but is not inflated. The infant's hand is then grasped and the rubber bandage wound tightly round the arm from hand to elbow so that the blood is expelled from the arm. When the bandage has been wound to the elbow the sphygmomanometer cuff is inflated to 200 mm Hg (this level is suggested since the actual height of the blood pressure is not known and may be well above normal for the infant's age). The rubber bandage is then quickly unwound. The lower arm should now be white in colour. Once this uncomfortable stage has been reached, if required, the pacifier or feeding bottle may be used to quieten the infant. When he is quiet, one observer (usually

the nurse) observes the white arm and the other observer slowly but steadily deflates the cuff while watching the manometer. When the end-point is reached a distinct pink flush spreads down the arm and the level of mercury in the manometer indicates the blood pressure. The flush may occur suddenly so that the observers must be consistently attentive or the end-point may be missed. Once the flush has occurred the technique cannot be reapplied satisfactorily to that limb for 15 minutes or more. The technique is used in the same manner to obtain the pressure in the leg.

### *Automated Blood Pressure Measurement*

Many hospitals now use automated blood pressure measurements that are derived from either a Doppler or oscillometric measurement from an inflated cuff. This removes the need for a mercury sphygmomanometer and allows for repeated, safe, accurate blood pressure measurements.

### **Intravenous Cannulation**

As with any procedure you must always introduce yourself and ask permission from the patient or parent before attempting the procedure. Intravenous cannulation is one of the most frequent procedures you will be expected to perform as a junior doctor. A "cannula" (from the latin meaning "little reed") is tube which can be inserted into the body for the delivery or removal of fluid. In children, consider whether EMLA cream or other dermal anaesthesia is appropriate prior to procedure as this needs to be applied about 45 minutes prior to the procedure to achieve adequate analgesia. Cannulae come in different sizes that are usually colour coded and an appropriate sized cannula should be selected (Fig. 38.3).



**Fig. 38.3:** Intravenous cannulae in different sizes



### Indication

- Administration of intravenous drugs, fluids or total parenteral nutrition.

### Equipment Required

- Intravenous cannulae
- Alcohol swabs
- Sterile drape
- Sterile gloves
- Extension set ( $\pm$  3-way tap)
- 5 ml syringe and flushed with saline
- Adhesive dressing
- Sharps bin.

### Method

1. Select a vein
2. Clean area and allow alcohol to dry
3. Restrain the extremity
4. Apply tourniquet (in children this is usually performed by another member of staff)
5. Pull skin taut to help stabilise the vein
6. Insert the needle through the skin a short distance prior to the chosen entry point of the vessel
7. Advance the needle until a 'flashback' is obtained
8. Slowly withdraw introducer needle a short distance
9. Advance cannula
10. Remove introducer
11. Connect extension set and flush cannula to ensure patency
12. Secure cannula using adhesive tape, bandage and splint if necessary
13. Dispose of sharps safely.

### Complications

- Infection—need sterile technique
- Phlebitis—increased risk with prolonged use (> 72 hours)
- Vasospasm—rare
- Haematoma—common if unsuccessful! Apply pressure
- Embolus air or clot—ensure extension set is flushed through fully
- Infiltration of subcutaneous tissue—can cause damage to tissue, e.g. TPN 'burn'.

### Intravenous Infusion

A scalp vein needle set is frequently of use and its advantages include rapidity of insertion, minimal trauma, and preservation of veins for future occasions. Alternatively it may be necessary to cut down on a vein (e.g. the saphenous at the ankle) of a shocked infant with collapsed scalp veins.

When a cannula is tied into a vein one may be confident that very rapid infusion can be given when necessary. For older children an arm vein or wrist vein may be cannulated using a plastic cannula set in preference to allowing a needle to traumatise the vein.

### Scalp-Vein Infusion

The scalp vein needle set is attached to a syringe containing physiological saline and air expelled from the dead-space of the set. The infant is restrained and the head held by the assisting nurse. Sedation at this time is not advisable since the distension of veins produced by crying makes entry of the needle easier. The scalp veins most constantly suitable for entry are on either side just behind or in front of the pinna of the ear or running down the middle of the forehead. In the shocked infant it is easy to mistake a scalp artery for a vein but the temporal arteries run in front of the ears rather than behind.

When a suitable vein is discovered the overlying hair should be shaved if necessary. The skin may be sterilised by 2% iodine in 70% ethanol which is removed with 70% ethanol to allow easier visualisation of the vein. A combination of stimuli may be required to distend the vein adequately. Venous return may be obstructed by having the nurse press her finger over a proximal segment. Tapping the vein sharply with the finger tends to relax it.

Enter the vein where there is a good length of straight vein downstream. Piercing the skin with the scalp vein needle may be difficult if the skin is tough. It may be easier to pierce the skin beside the vein and insert the needle a short distance under the skin before completing the venepuncture. Venous spasm and vein rupture may thus be avoided. When the vein is entered blood flows back into the plastic tubing. This may not happen in the collapsed infant. Small quantities of fluid are injected from the syringe believed to be in the vein and if the needle is not in situ a subcutaneous bleb appears.

After the vein has been entered it is easy for a restless infant to dislodge a scalp vein needle. The needle should be inserted as far as possible into the vein. With the needle adequately in the vein, tape it to the scalp with paper tape, plaster of Paris, or sterile adhesive spray. Also tape a loop of the connecting tube to the adjacent scalp.

Usually fluid administration is by gravity controlled drip. Drops-per minute may be converted to millilitres per hour depending upon the calibration of type of set used. Axiomatically the quickest way to stop a drip is to slow it excessively which leads to clotting in the needle and the end of that drip. Nursing staff must realise that excessively rapid infusion cannot safely be compensated for by severely slowing the drip. Volume may better be controlled by using a peristaltic or other controlled pump. A number of adjusting

volumeters which give an accurately dispensed volume per unit times are available. Membrane filters with controlled dimension micropores are available as a final filter for air bubbles and other particulate matter. The accidental entry and subsequent growth of micro-organisms converts the infusion fluid pathway into a potential vehicle for infection with micro-organisms. Therefore, strict aseptic procedure should be followed.

### *Cut-Down Infusion*

Cut-down techniques are widely known. The important point for the paediatrician is to ensure that the instruments are of appropriate size, are sterile and the scissors sharp. In a general hospital with central services, it is commonplace to find sets with large forceps and scissors totally unsuitable for delicate work on an infant. The infant should be kept warm and oxygenated. The leg is externally rotated and bound to a padded splint. The incision is made above the medial malleolus and at right angles to the vein which is freed from surrounding tissue by dissection. A ligature tied distally round the vein occludes venous return and a small transverse incision on the upper surface of the vein allows insertion of a plastic cannula. The cannula is passed well up the vein and a second ligature just above the site of insertion secures it in place. The wound is then closed with two stitches or adhesive strips. The handling necessary and the infusion of cold fluid may result in venous spasm and poor initial flow through the cannula. This needs not mean unsuccessful technique and patience and warmth will allow venous spasm to resolve. Imaginative and dexterous use of the scalp vein sets in a variety of non-scalp areas (e.g. wrist, elbow, arm, ankle, foot) greatly reduces the need for cut-down procedures.

### **Intraosseous Needle Insertion**

In a shocked patient when a pulse is feeble or not palpable and blood pressure is very low or not recordable then it maybe that all peripheral veins are so collapsed it is difficult or not possible to get access quickly. It is suggested by the Paediatric Life Support Manuals that intravenous access can be tried for a maximum of three attempts or up to 60 seconds. If access could not be achieved by this, time should not be wasted anymore and an intraosseous route should be obtained for a quick and efficient infusion to fill the vascular tree.

#### *Indication*

- Failed intravenous access in a shocked patient.

#### *Contraindications*

- Fracture of that bone—absolute contraindication (e.g. fracture tibia)

- Fracture of a long bone proximal to the location (i.e. fracture of femur with large haematoma which might interfere venous drainage for infusion in tibia—relative contraindication)
- Unhealthy skin condition or loss of skin (e.g. burn) is not contraindications.
- Bone marrow depressant drugs should not be infused.

#### *Equipment Required*

- Appropriate size sterile gloves
- Cleaning agents, towels
- Local anaesthetic drug (e.g. 1% lidocaine)
- 5 ml and 20 ml syringes
- 20–22 gauge needles
- Intraosseous needle (Fig. 38.4)
- Thread or tape to fix the needle
- 3-way tap and tube
- Splint
- Infusion fluid.

#### *Method*

1. Wash and dry hands with sterile towels
2. Wear gloves, non-touch technique
3. Clean and towel the area, exposing from the patella to about proximal  $\frac{1}{4}$  of leg on anterior and medial aspect
4. Identify tibial tuberosity (run your finger in the midline from below the patella, the first bony prominence on the proximal part of tibia) (Fig. 38.5).
  - If the child is conscious enough to feel the pain, inject local anaesthetic agent on the medial side, about 1–2 finger-breadths below the horizontal line from the tibial tuberosity and wait for about 15–20 minutes
  - Take the intraosseous needle



**Fig. 38.4:** Intraosseous needle

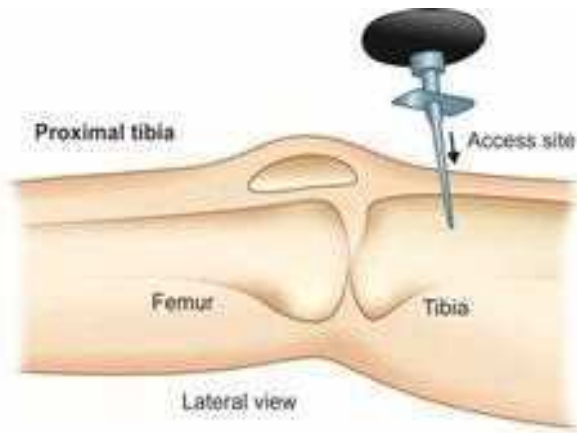


Fig. 38.5: Intraosseous needle insertion

- Rough estimation of the depth to reach the centre of the bone (i.e. bone marrow) and keep the needle, with head against the head of index finger metacarpal and three fingers gripping the needle for the estimated depth
- By clock and anticlockwise screwing movements, at right angle (90 degrees) to the surface of the bone, introduce through the cortex to the marrow (considerable force may be required when the cortex is thick). The needle should stand at 90 degrees when left free.
- Attach a tube with 3-way tap
- Fix the needle and the tube with thread or tape and then splint the joint
- Inject or infuse the fluid (warm enough)

### Pitfalls

- The infused fluid is drained by the veins supplying the marrow. If that bone is fractured, all/most of the fluid will be drained through the fracture site.
- This is an intraosseous infusion and needle should be introduced into the bone (i.e. on the medial side of tibia). It becomes intramuscular route if injected on the lateral side of the proximal part of the leg.
- Oblique insertion will result in the bone entering in the subcutaneous area.
- Too strong a force, not limited to the estimated depth, may result in penetration of the opposite cortex and the technique will fail (becomes intramuscular infusion) and that bone cannot be used again.
- The patient may lie down still when shocked, but when the circulating volume improves, the child may regain conscious state and start kicking the legs with the possibility of dismantling the needle—a good splinting may avoid this problem.

### Complications

- Infection
- Septicaemia
- Fat embolism.

### Suturing

Suturing of wounds is a basic practical procedure that any doctor must be competent in. The basic steps are described below and illustrated in Figures 38.6A to F.

### Wound Preparation

Every wound should be assessed in terms of its location, its margins, injury to, and viability of deeper structures and tissue, the presence of foreign body in the wound and the degree of contamination. The location of the wound could well dictate the type of anaesthesia, wound washout required and the type of sutures and suturing needed. The margins of the wound should be healthy and viable, and should come together without undue tension. If the margins or wound edges are ischemic or necrosed they need to be debrided and freshened. It is also important to exclude either by direct visual examination or by radiology the presence of any kind of foreign body in the wound. The degree of wound contamination could well decide whether a general or local anaesthesia would suffice, the type of wound toilet and washout and the type of sutures and suturing required. The wound needs to be thoroughly cleaned with sterile saline or an antiseptic solution under anaesthesia.

### Local Anesthesia

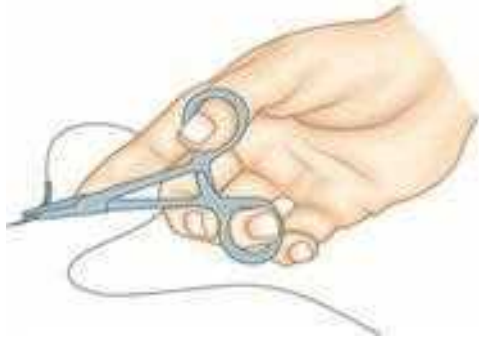
See section on sedation and analgesia.

### Sutures Including Type and Size of Sutures

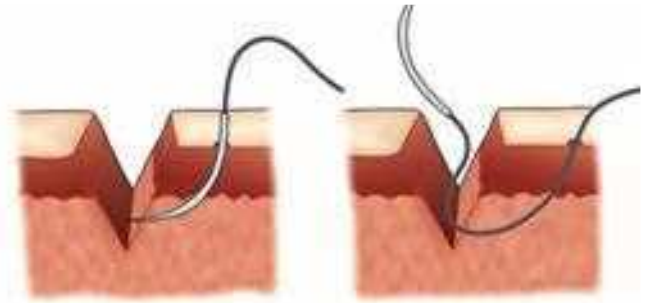
Basically suture materials come with two very important characteristics. They are either Absorbable or Non-absorbable. Absorbable sutures are absorbed by the body after several weeks or months. These include Polyglactin 910 (Vicryl, Ethicon), PDS II (Polydioxanone, Ethicon), Polyglycolonate (Maxon, USS/DG), Poliglecaprone 25 (Monocryl, Ethicon), etc.

Non-absorbable monofilament and multifilament include silk, braided synthetics, monofilament synthetics including prolene, ethibond, nylon, etc.

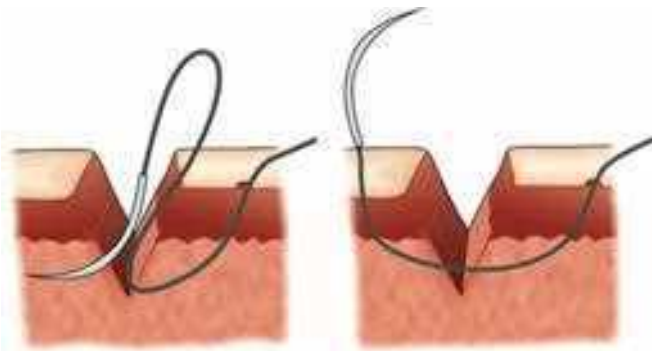
Absorbable sutures are used when continued strength is not important. It is also an important advantage in paediatric patients where sutures are absorbed and do not require to be removed. They are used for subcutaneous tissues and subcuticular skin closures. The non-absorbable suture is used when continued strength is important, and when minimal reaction is important. These include uses in skin and fascial closure and for vessel anastomosis.



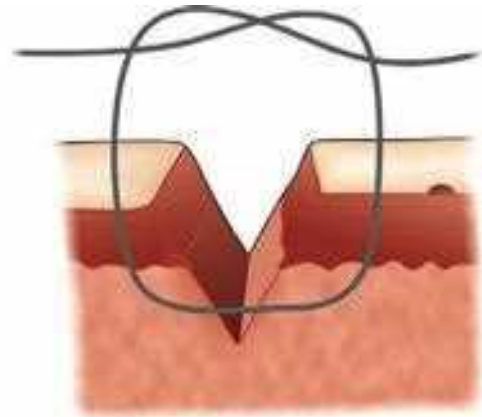
**Fig. 38.6A:** Gripping a suture needle with a needle driver



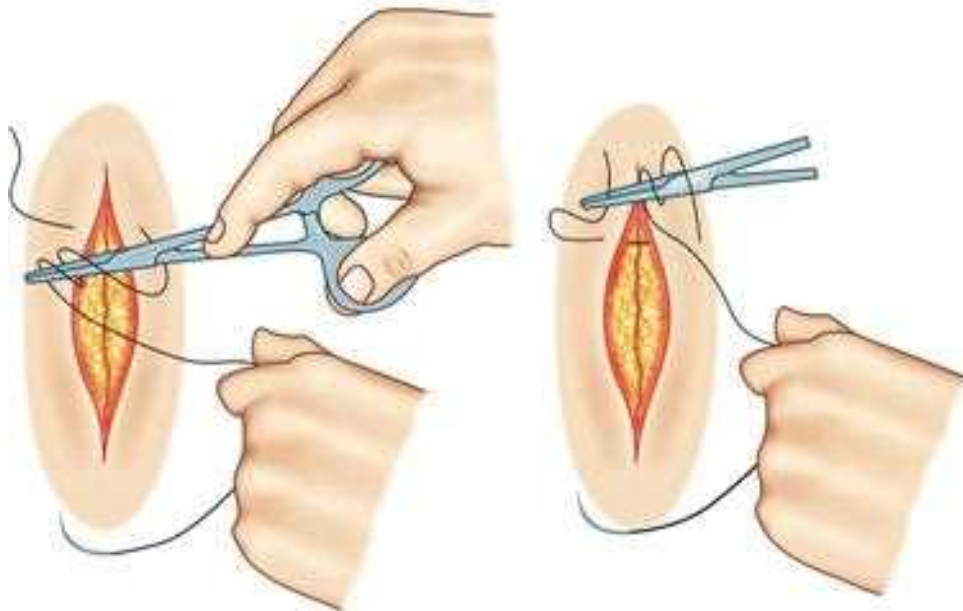
**Fig. 38.6B:** Needle pushed through skin and out into the base of the wound. Suture pulled through first side of wound



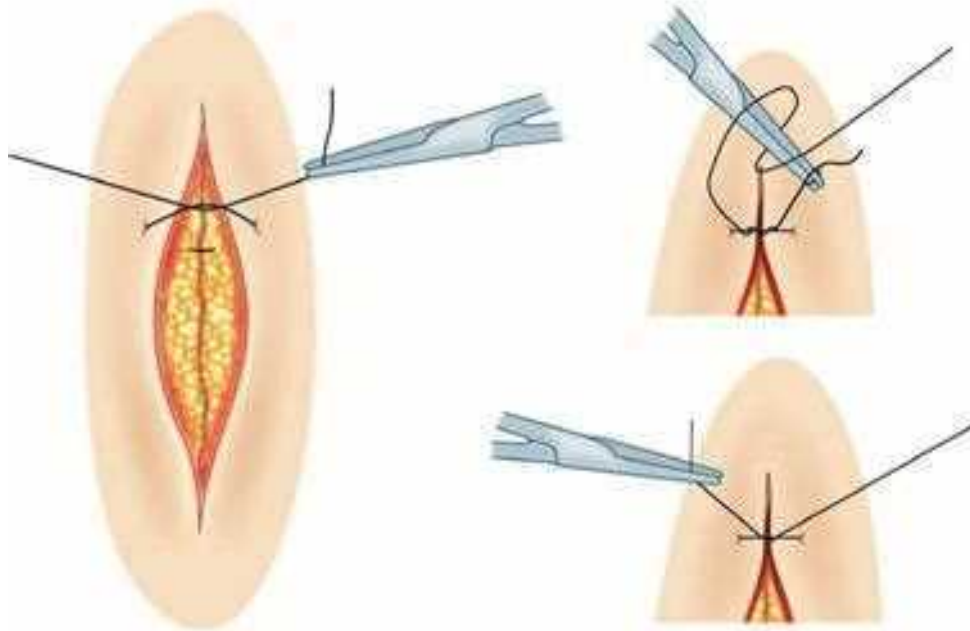
**Fig. 38.6C:** Needle pushed into the base of the opposite side of the wound. Needle rotated out through second side of the wound



**Fig. 38.6D:** The U shape of proper suture placement



**Fig. 38.6E:** Loop the suture twice around the needle driver. Grab the short end of the suture with the needle driver



**Fig. 38.6F:** Laying down first loop of a knot. Create second single loop in opposite direction. Square knot complete

Size of suture starts with 0 as the heaviest and works down to 7/0 which is very fine. The smaller the gauge the heavier the suture and the greater the strength.

### Types of Needle

Different types of needles are available including round tapered, conventional cutting, reverse cutting, tapercut, etc.

Needles used in deeper tissues including vessels, subcutaneous tissues, etc. include cutting and reverse cutting needle. Needles used for skin closure should be cutting and reverse cutting, as they are atraumatic and pierce the skin easily.

### Instruments

Basic instruments required for suturing include the needle holder, tooth forceps, non-tooth forceps, scalpel and suture cutting scissors. Other requirements including cleaning and preparation of solution, gauze swabs and drapes.

Handling of instruments: Knowledge of technique and instruments allows for a safe and competent procedure. Sutures are placed on wounds with the use of tissue forceps either tooth or non-tooth forceps and a needle holder. Needle holders are like artery forceps except their tips are shorter with a grooved jaw to hold a needle securely. The usual method to mount a needle is two-thirds of the way proximal on the needle with its axis perpendicular to

the long axis of the needle holder. Once used the needle should be moved along the side of the needle holder tip to sheath the tip of the needle. Once the suture is placed the redundant suture is cut above the knot using two hands for better control.

### Basic Techniques Including Interrupted and Mattress Sutures

Basic suture patterns include interrupted, mattress and continuous sutures.

An interrupted suture consists of single stitches placed in a row and each stitch had its own knot. A continuous suture begins with an initial knot and runs continuously to the other end of the wound before the finishing knot is tied.

The most useful mattress suture is the vertical mattress suture which takes deep and superficial bites providing maximum suture strength and everting the wound margins. Common practice is to remove sutures from the face in 3–5 days whereas sutures on the limbs, hands, knees, elbow and trunk after 7–10 days.

### Nasogastric Tube

A nasogastric tube is inserted for urgent or elective reasons. The tube is introduced through either of the nostrils and is negotiated through the oesophagus so that the tip is lying in the stomach (Fig. 38.7).

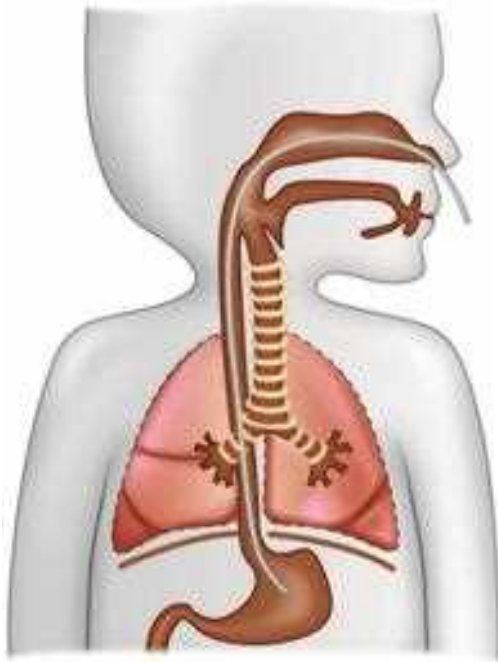


Fig. 38.7: Nasogastric tube

### Indications

- For drainage of gastric content, for example intestinal obstruction (pre- and post-operative)
- For feeding in medical and surgical patients when the patient is not allowed or not able to eat/drink through the mouth.

### Contraindications

- Trauma to nose/oro-pharynx/oesophagus/stomach
- Basal skull fracture
- Thermal/caustic injuries to nose/oro-pharynx/oesophagus/stomach
- Oesophageal obstruction/perforation

### Equipment Required

- Appropriate size sterile gloves
- Cleaning agent
- Nasogastric tube appropriate size (8–12CH for children, 6CH feeding tube for preterm)
- Neonate/baby—with green line (if X-ray is required)
- Lubricant (e.g. sterile K-Y jelly)
- 5 ml and 20 ml syringes
- Stethoscope
- Litmus paper or pH reaction chart
- Adhesive plaster

### Method

1. Introduce yourself to the patient and explain the procedure
2. Keep the head straight, facing the roof
3. Measure the length of the tube to be kept in (lying position—from the nostril to the angle of the jaw posteriorly and turn vertically till the epigastrium)
4. Lubricate to the measured length
5. Clean the nostril
6. Pass the tube gently through the nasal passage to the measured length, without any resistance (patient will cough or pull the tube if it enters respiratory tract)
7. Inject air and listen to the sound in the epigastrium (not in the chest)
8. Aspirate the content and test with litmus paper or pH reaction chart (should be acidic, if the tube is in stomach)
9. Use adhesive plaster to stick the tube on the ipsilateral cheek
10. X-ray to confirm the position of the tube (green line), if necessary.

### Pitfalls

- Basal skull fracture—the tube can enter the cranial cavity
- The tube should not be pushed forcibly if there is resistance (obstruction) or cough (wrong passage)
- The tube may coil in the pharynx (without any resistance) and can come out through the mouth!

### Complications

- Perforation (especially after thermal/caustic injuries)
- Too large size can traumatise the nostril and proximal nasal passage

## Urinary Catheterisation in the Male and Female

Urethral catheterisation is a useful procedure in emergency and elective situations so that hydration status of the individual can also be ascertained. A sample of urine can be obtained for urinalysis at the bedside as well for laboratory investigation. Strict antiseptic and atraumatic procedure should be carried out to avoid complications. It is important to explain the procedure to the child and child carers before starting.

### Indications

- In an emergency situation, e.g. multi-trauma patients, for noting hourly urinary output
- For major operative procedures in bladder, urethra, penis
- To relieve acute retention of urine

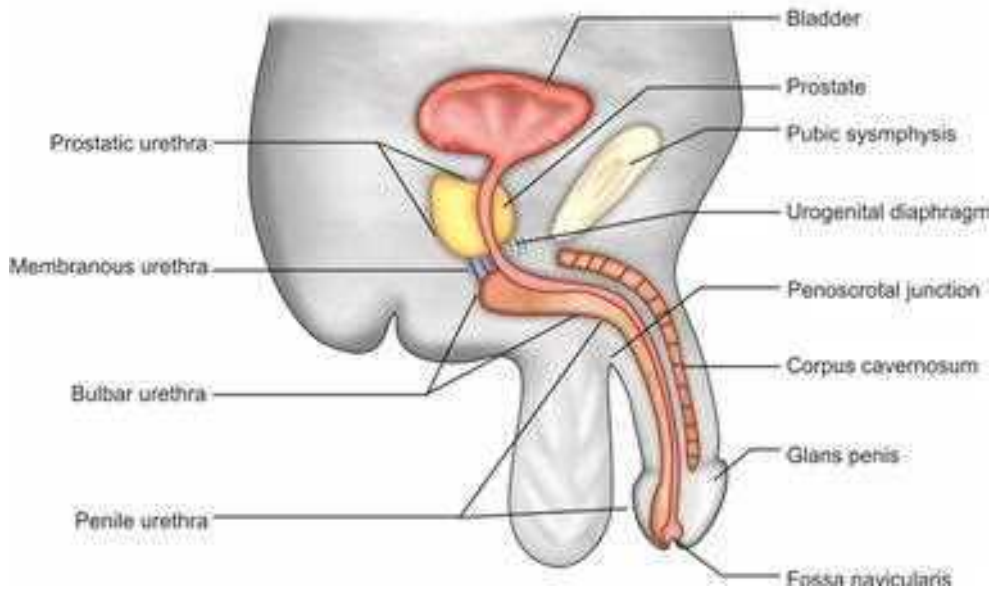


Fig. 38.8: Male urethra

- To obtain a urine sample for laboratory investigations—rarely done
- For 24-hour collection of urine for various laboratory investigations.

**Contraindications**

- Urethral injuries
- Infection of the distal urethra, glans, prepuce (infection may be introduced proximally into the sterile bladder during catheterisation)
- Post-operative hypospadias repair.

**Relevant Anatomy**

Male urethra (Fig. 38.8).

**Equipment Required**

- Appropriate size sterile gloves
- Foley catheter (8, 10, 12 CH size for children, 6 CH feeding tube for small/preterm babies/neonates)—silastic catheter if the catheter has to stay for longer period
- Cleaning agents, towels
- Sterile lubricant (e.g. K-Y jelly, lidocaine gel)
- Sterile container to receive urine sample
- Sterile water and 10 ml syringe
- Urinary bag
- Adhesive plaster.

**Method (Boys)**

1. Wash and dry hands with sterile towels.
2. Wear gloves, non-touch technique.
3. Take the appropriate size Foley catheter from the sterile inner cover (size is printed in the limb of the catheter).
4. Inject 2–3 ml sterile water in the short limb of the catheter and check balloon for any leaks and deflate.
5. After cleaning, draping with towels should be done exposing the suprapubic and genital area.
6. Estimate the length of the tube required to be in, from the tip of penis to just above the symphysis pubis.
7. If prepuce is intact, retract and expose glans and clean
8. Open the external urethral meatus and clean.
9. Insert instill a gel/lidocaine gel.
10. Introduce the Foley catheter gently and smoothly through the urethra to the bladder till urine escapes through the long limb of the catheter.  
You may encounter resistance at the prostatic/external sphincter. If this occurs:
  - Stop and allow the sphincter to relax
  - Lower the penis towards the perineum and continue to advance the catheter.
  - Abandon the procedure if the catheter did not advance or if the patient is in discomfort and seek senior advice. Never inflate the balloon unless you get urine from the catheter.
11. Once you are happy the catheter is in place, inject 5–10 ml of sterile water through the short limb of the

catheter (to inflate the balloon—maximum for injection is printed adjacent to the catheter size).

12. With a gentle pull, the inflated balloon will move to the bladder neck and is self-retaining.
13. Use the adhesive plaster to fix the catheter on the thigh or suprapubic area.
14. Connect the long limb of the catheter to a urinary bag for continuous drainage.
15. Fix the tube to thigh with adhesive plaster.
16. Always replace the foreskin to prevent paraphimosis.

### Method (Girls)

- 1 to 5 (Same as the method of boys mentioned above)
6. Estimate the length of the tube required to be in, from the tip of urethra to just above the symphysis pubis (Fig. 38.9)
7. As above
8. Clean labia majora, open labia and clean urethral meatus and labia minora
- 9 to 15 (Same as the method of boys mentioned above).

Always document in the patients notes a procedure note, carefully dated and stating size of catheter and amount of water in the balloon, and the residual urine volume.

### Complications

- Infection
- Trauma to urethra/external urethral meatus (Fig. 38.10)
- Bleeding
- Blockage of catheter and bypassing of catheter
- Paraphimosis from failure to protract foreskin
- False passage creation and stricture formation.

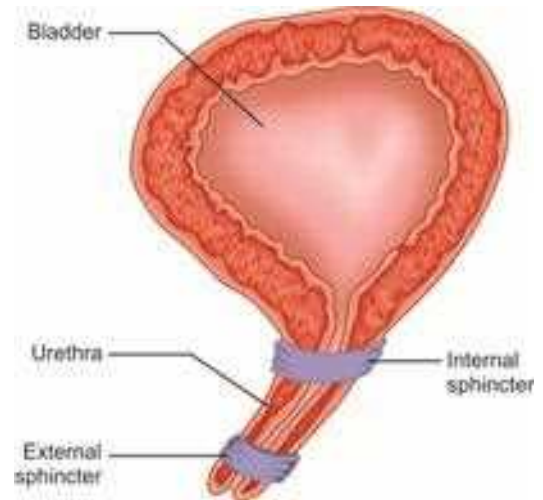


Fig. 38.9: Female urethra

### Urinalysis

Bedside chemical analysis of urine can be done using chemical strips. The manufacturing company indicates the details of when to read the results after dipping the strip in the urine and to match the colours against various constituents of urine.

For bacteriological and other special studies such as urgent microscopy, the urine sample should be sent to the laboratory immediately, as long standing exposure to the atmosphere may cause contamination.

The common reagent strips are used to identify the presence and amount of constituents of urine—protein, pH, blood, specific gravity, ketone and glucose.

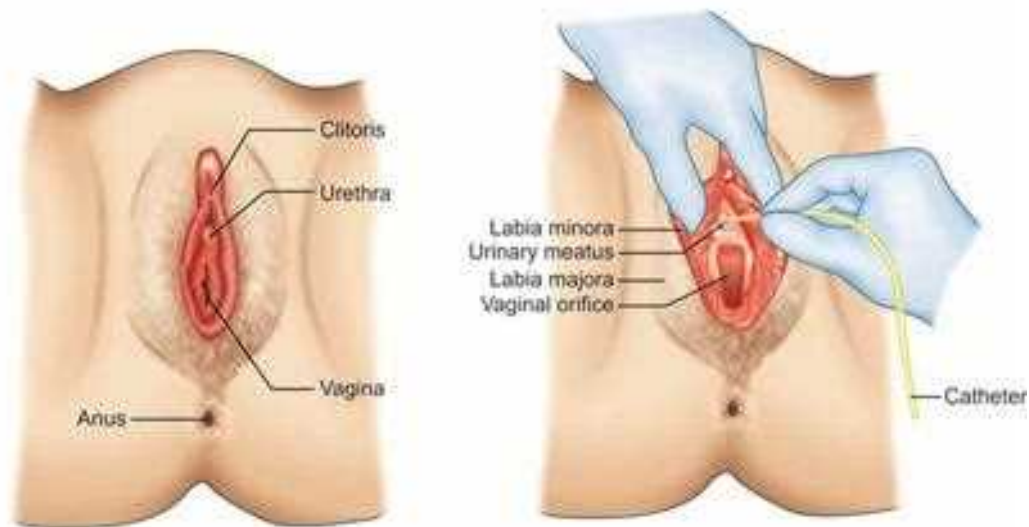


Fig. 38.10: Female external urethral meatus



**Method**

1. After taking samples for microbiological study and other special tests, dip the strip till all the reagents are smeared with urine
2. Keep the strip on table or sink, reagents facing upwards
3. After the appropriate time (as mentioned by the company leaflet) match the colours of the reagents against the colours on the container. Note the results for each chemical constituent (Fig. 38.11).

**Urinalysis Interpretation**

**Urine pH:** Normal range is from 5.0 to 9.0. Normally, if the serum is acidic, the excess cations will be excreted in the urine, driving the pH down. Similarly, excess anions of alkalemia drive the urine pH up.

**Ketones:** They are elevated in dehydration, fasting, or DKA (diabetic ketoacidosis—seen in Type I diabetics).

**Hemoglobin** if elevated, without red cells present: Haemolytic anaemia (transfusion reaction?); error caused by lysing of old sample. With red cells present: Bladder

trauma; tubular damage. With red cell casts present: Glomerulonephritis.

**Bilirubin:** This refers to conjugated bilirubin. This is elevated in post- or intra-hepatic obstruction.

**Urobilinogen:** This is elevated in conditions with high unconjugated bilirubin, such as hemolysis or Gilbert's disease.

**Nitrite:** This is elevated when bacteria (particularly gram negative organisms, generally faecal) are present in the urinary tract. The organisms that convert nitrate to nitrite are *Escherichia coli*, *Enterobacter*, *Citrobacter*, *Klebsiella* and *Proteus*. They take about 4 hours to do the conversion, so your best bet is a urine that's been waiting at least that long such as a morning void.

**Leukocyte esterase:** This enzyme is made by neutrophils as a response to the presence of bacteria and is an indicator of UTI.

**Glucose:** Glycosuria means a serum glucose of greater than 180. It is not normal.

**Protein:** Usually albumin more than other proteins. If elevated, urinary protein indicates UTI, recent exercise or renal disease.

**Specific gravity:** This is used to infer volume status, which you should be able to assess clinically with more accuracy than this test will provide. If specific gravity is elevated, that means the urine is concentrated, suggesting a hypovolaemia. If the specific gravity is low, that means the urine is dilute, suggesting hypervolaemia.

**Casts:** They are associated with the collection of cells in the distal tubule, which become concretions after sufficient time has elapsed. They are generally associated with different conditions dependent on their colour: red—nephritic syndrome; white—pyelonephritis; muddy brown—renal failure; crystals—seen in gout, kidney stones, or in the presence of some drugs.

**Blood Glucose**

A glucose meter (or glucometer) is a medical device for determining the approximate concentration of glucose in the blood. A small drop of blood, obtained by pricking the skin with a lancet, is placed on a disposable test strip that the meter reads and uses to calculate the blood glucose level. The meter then displays the level in mg/dl or mmol/L. The size of the drop of blood needed by different models varies from 0.3 to 1 µl. Most glucometers today use an electrochemical method. Test strips contain a capillary that sucks up a reproducible amount of blood. The glucose in the blood reacts with an enzyme electrode. The total charge passing through the electrode is proportional to the amount



**Fig. 38.11:** Analysis of urine using chemical strips



Fig. 38.12: A selection of glucometers



Fig. 38.13: Pulp of finger and spring loaded lance to the site

of glucose in the blood that has reacted with the enzyme (Figs 38.12 and 38.13).

### Causes of Hypoglycaemia and Hyperglycaemia

The list of causes of hypoglycaemia and hyperglycaemia are extensive; some are listed in the Table 38.2.

#### Indications

- Used to monitor glucose level in patient with diabetes
- Used to monitor glucose level in patient receiving TPN
- Used in emergency to rule out hypoglycaemia

#### Equipment Required

- Glucose meter
- Testing strip
- Alcohol swab

- Lancet
- Cotton wool
- Gloves
- Sharps bin

#### Method

1. Choose injection site; pulp of finger in older children; heel in younger children and babies
2. Clean site with alcohol swab and allow to dry
3. Apply the spring loaded lance to the site and warn the patient they will feel a sharp scratch
4. Fire the lancet
5. Express a droplet of blood by squeezing the finger or heel. Express the droplet onto the test strip and insert into glucometer. Ensure it signals it is analyzing.
6. Apply pressure with cotton wool to the puncture site
7. Apply a dressing if required.

A normal reading is 4 mmol/L or 72 mg/dl. It is widely accepted; however, that glucometers have a nationally accepted standard error of  $\pm 20\%$  and, therefore, if there is any doubt regarding the reading a serum glucose sample should be sent.

## OTHER PRACTICAL PROCEDURES

### Central Venous Access

Central venous access provides venous access as well as measurement of central venous pressure. The aim of central

Table 38.2: Causes of hypoglycaemia and hyperglycaemia

Hypoglycaemia	Hyperglycaemia
Transient neonatal hypoglycaemia	Diabetes mellitus—type I and type II
Prolonged fasting	Drugs—e.g. $\beta$ -blockers, epinephrine, thiazide diuretics, corticosteroids
Congenital hypopituitarism	Physiological stress
Congenital hyperinsulinism,	Critical illness
Inborn errors of carbohydrate metabolism	Infection
Insulin-induced hypoglycaemia	Inflammation
Insulin-injected for type 1 diabetes	
Munchausen syndrome	
Insulin-secreting pancreatic tumour	
Reactive hypoglycaemia and idiopathic postprandial syndrome	
Addison's disease	
Sepsis	

venous catheterisation is to insert a large bore catheter into a large central vein. Strict asepsis during insertion is essential and many centers now utilise a “central line bundle” approach during central line insertion to improve adherence to aseptic technique and therefore minimise the risk of infection. During the procedure, a needle is placed in the vessel and an internal guide wire inserted into the vein first. This is known as the Seldinger technique. The needle is then removed over the guidewire, the track into the vessel lumen dilated and the cannula threaded along the wire into the lumen. This involves the subclavian or internal jugular vein. The femoral vein also may be used and preferred by many. The indications of central venous catheterisation are:

- Measurement of central venous pressure
- Infusion of drugs
- Total parenteral nutrition.

The equipment required for central venous line is available in pre-packaged central line sets. These central venous lines are, as time goes by, increasingly difficult to protect from the entry of bacteria, sepsis is likely after 5–10 days, although careful care and strict asepsis decreases the incidence. However, some paediatric intensive care units (PICUs) judge it wise to change all central venous lines every 5 days. If the line is needed for long-term therapy (e.g. chemotherapy or TPN) then a subcutaneously tunnelled line should be used. An alternative for intermittent therapy is to place a port with venous access subcutaneously (Portacath).

Central venous line landmarks:

- Femoral vein—one fingerbreadth below midpoint of the inguinal ligament just medial to the femoral artery
- Internal jugular vein—junction of the sternal and clavicular heads of sternocleidomastoid muscle, just anterior and lateral to the carotid artery. Aim needle towards ipsilateral nipple.

### Complications of Central Venous Access

These include pneumothorax, haemothorax, hydrothorax, air or catheter embolism, and brachial plexus injury. Preparations always should be made to treat them and a chest X-ray should be performed after internal jugular or subclavian line insertion. Cervical haematomas are common, and although bleeding is usually trivial, it can produce occlusion of the airway. The biggest risk however is that of central line infection which usually mandates removal of the line.

### The Sweat Test (Chloride Sweat Test, Cystic Fibrosis Sweat Test)

Analysis of sodium and chloride content of sweat is indicated in the diagnosis of cystic fibrosis (CF). Normally, sweat on the skin surface contains very little sodium and chloride.

People with CF have 2–5 times, the normal amount of sodium and chloride in their sweat. Generally chloride (sweat chloride) is measured.

### The Iontophoretic Method

This is a convenient method in that only a small area of skin is sweated. It may thus be used on patients of all ages including small infants.

### Requirements

- The sweat box unit supplies a small current to the appropriate skin area via two terminals.
- Magnesium sulphate solution, 0.1 N.
- Aqueous solution of pilocarpine nitrate, 0.2%.
- Lint, “Sleek”, polythene sheeting and de-ionized water.
- A piece of filter paper previously weighed in a container labelled with the patient’s name.
- Forceps
- A warm room.

The child’s limbs and trunk are exposed. For each terminal a piece of lint is cut slightly broader than the terminal: it is folded twice to give thickness and placed on the terminal. The black lead (negative pole) lint is thoroughly dampened with magnesium sulphate solution: the lint is placed on the anterior aspect of the child’s thigh and the terminal placed over it (i.e. the lint is between skin and terminal) and taped firmly in place with a strip of Sleek or other suitable adhesive.

The red lead (positive pole) lint is thoroughly dampened with pilocarpine and applied in a similar manner to the area of skin which is to be sweated. The scapular area is found to be satisfactory in most cases. The terminal wires are attached to the appropriate buttons on the sweat box unit and the unit switched on. The current control is slowly increased until a steady current of between 4 and 5 milliamperes is reached and this current is maintained for 5 minutes after which the unit is switched off and the lint and terminals removed. The skin area to which pilocarpine was applied is now thoroughly washed with deionised water and carefully dried. The weighed filter paper is removed from its container with forceps and placed on the skin area: a piece of polythene sheet, slightly larger than the filter paper is placed over it and taped firmly in place with Sleek which should seal the edges of the polythene to prevent leakage. It is useful to apply the Sleek in four strips leaving a ‘window’ in the centre of the polythene. The child may now be dressed and may resume his ordinary ward activities. The polythene window is examined 30 minutes later—if sufficient sweat has been collected then the filter paper becomes almost transparent, if this is not apparent it is worth leaving the paper in situ for a further 30 minutes.

The polythene and Slick are then removed—the paper carefully placed in its weighed container using forceps and sent to the laboratory for analysis together with a control piece of filter paper. The minimum weight of sweat required for electrolyte analysis by this method is 100 mg. When the current is being applied the child may experience a tingling sensation but provided no more than 5 milliamperes is used this should not be uncomfortable. Sometimes the area of skin under the terminals becomes reddened or may even show an urticarial eruption but this will readily settle. The only complication we have experienced with this method has been a small skin burn due to careless application of a terminal which touched the skin. This is avoided if the lint is of larger area than the terminal, but even so care should be taken with a wriggling child lest the terminal slip during this stage of the procedure.

#### Key Learning Point

##### Chloride sweat test

- ⇒ Sweat chloride concentration greater than 60 mmol/kg is diagnostic of CF.

### Radial Artery Puncture

The skin is cleansed in the usual manner. A suitable size needle (gauge 21 usually) is attached firmly to a syringe and the dead space filled with heparin. The infant's hand is supinated and held so that hand and forearm are straight, i.e. no wrist flexion or extension. The needle is inserted through the proximal wrist skin crease over the radial pulsation and at an angle of about 60 degrees to the skin—it is pushed thence till it just touches the radius whence with slight negative pressure on the syringe it is slowly withdrawn along its line of entry, withdrawal ceasing when blood is obtained. After arterial puncture the syringe is sealed, e.g. with a syringe cap or portion of plasticine. An assistant maintains firm and unvarying pressure on the puncture site for 5 minutes or till unvarying pressure on the puncture site for 5 minutes or till all bleeding has ceased. In the older child a small dose of local anaesthetic may be injected at the site of puncture before the procedure is performed.

### Arterialised Capillary Blood

A satisfactory alternative to arterial puncture is the use of arterialised capillary blood. It has the advantage that blood is always obtained and that sampling may be freely repeated as often as required. In the infant the heel is the best site to prepare; in the older child the ear lobe or digital pulp is used. The skin is cleaned in standard fashion. If the site is flushed and warm no further preparation may be needed. Squeezing the site is obviously contraindicated in obtaining samples for PO<sub>2</sub>. Following preparation the skin is incised

briskly with a sterile lancet and blood collected in heparinised glass capillary tubes whose ends are sealed with plasticine. The analysis for PO<sub>2</sub> should be made within 15 minutes of sampling.

### Haematological Procedures

#### *Precautions in Patients with Haematological Disorders*

To patients with haemophilia or leukaemia their veins are their 'lifelines'. Venepuncture should be kept to a minimum and laboratories dealing with children should be geared to perform their tests upon capillary samples of blood unless this is not practicable. When venepunctures are unavoidable (usually due to the need for therapy or for transfusion) it is best not to use the antecubital fossae since extravasation of blood or infused drug can easily occur undetected. Perivenous haematoma are a potent source of infection and of great hazard in either leukaemia or haemophilia. The veins on the back of the hand (or foot) can be used with far less chance of undetected extravasation during injection and easier control of haemostasis by subsequent application of pressure using sterile cotton wool. Scalp veins provide similar access in infants but tests using capillary samples are particularly important for this age group.

#### Key Learning Points

- ⇒ In absolutely no circumstances should any intramuscular injection be given to a child with haemophilia or Christmas disease.
- ⇒ Likewise, no intramuscular injections should be given to children who are grossly thrombocytopenic or are receiving heparin therapy.

### Marrow Aspiration

It is convenient to perform the whole procedure 15 minutes after the patient has been sedated. With the patient in the 'LP' position the posterior superior iliac spine located at the lower end of the crest. It is helpful to mark the line of the crest with the iodine used as a skin antiseptic. With the crest grasped between thumb and forefinger the skin, subcutaneous tissue and periosteum is infiltrated with 2 ml of 1% xylocaine (or equivalent) at a point 1 cm above the spine in young children and 2 cm above it in older children using a fine needle. During infiltration move the point of the needle a few millimetres first one way and then the other across the surface of the crest so as to define the exact limits of its subcutaneous surface. Allow 2 minutes for the local anaesthetic to become effective and then using strict aseptic technique push a marrow puncture needle and trocar of relatively wide bore (1.5 mm) through the skin with a rotating action down to

the periosteum and locate the most central subcutaneous portion of the crest. The needle and trocar are then directed in a strictly anterior direction (in all planes) and pressed into the bone with an alternate clockwise and anticlockwise boring action with a firm movement. As soon as the needle is sufficiently inserted into the bone to remain fixed by itself without support the trocar is briskly withdrawn. A fleck of pink marrow may be seen on the tip of the trocar confirming that the needle is within the marrow cavity. Strong suction is then applied with a 20 ml sterile syringe and stopped after about 0.2 ml of blood (and marrow) enters the syringe. If nothing can be aspirated the trocar is replaced, the needle advanced a further 1–2 mm and aspiration repeated. If still unsuccessful the procedure is repeated 1–2 mm on either side of the original position. After obtaining aspirate the trocar is replaced and the needle withdrawn covering the puncture site with a sterile dressing. The aspirate is expelled in equal amounts on to 8–10 microscope slides in succession and the surplus fluid blood is sucked back into the syringe. Smears are made of the sedimented marrow cells and particles and the slides waved in the air to achieve rapid drying. The remaining iodine is removed from the skin with surgical spirit and a sterile adhesive and occlusive dressing placed over the puncture site.

#### Key Learning Point

##### Marrow aspiration

- Marrow puncture is contraindicated in haemophilia or Christmas disease but is safe in the presence of even severe thrombocytopenia, when care is taken to ensure continued firm pressure after the procedure.

### Marrow Trepine

This is performed at the site as above in children aged more than 1 year. A Gardner bone marrow trephine needle and trocar used. The trocar locates the bone and the saw-toothed needle is then rotated down to the surface of the bone and thereafter rotated in one direction with steady pressure. As the needle cuts into the bone the head of the trocar is gradually pushed back out of the needle helping to indicate the depth to which the needle has penetrated. When this is thought to be 5 mm a syringe is attached so as to exert gentle suction while the needle is withdrawn, after which a slender cylinder of bone and adjacent marrow can be extruded from the needle into a suitable histological fixative such as used in the local laboratory.

### Tibial Puncture

This site is used for marrow puncture in preference to the iliac crest for an average child up to 6 weeks or in very small babies up to the age of 3 months. It is important to

avoid damaging the epiphysis in the region of the tibial tubercle since a disturbance of bone growth could occur in later life. The subcutaneous antero-medial surface of the tibia is palpated and the tibial tubercle identified. A site in the middle of the subcutaneous surface 2.5 cm (1 inch) below the tubercle is chosen. A needle with a guard is used to puncture the skin and then the bone with a ‘boring’ motion keeping the needle strictly at right angles to the subcutaneous surface of the bone. When the needle point touches the periosteum before entering the bone the guard is adjusted to allow bone penetration to a depth of 2–3 mm. In other respects the procedure is as described for the posterior iliac crest puncture.

### Stains in Common Use

In the side room or laboratory, which should be attached to every ward, a number of simple stains should always be available and should be kept fresh. These would certainly include methylene blue, carbol fuchsin and Gram’s stain.

#### *Methylene Blue Stain (0.5% Aqueous Solution)*

Methylene blue films can be made so rapidly that it is surprising that this procedure is not used freely and widely. Scrapings of the buccal mucosa (for thrush), a faecal smear (for deposit of polymorphs seen in bacterial dysentery), or a single loop-full of the centrifuged deposit of CSF from a case of suspected meningitis (for bacteria and leucocytes) may be applied thinly to the slide and to dry and then fix by passing three times through a Bunsen flame. The slide is then stained with methylene blue for 1 minute, washed in water, dried and examined under oil immersion. The whole procedure need takes no more than 5 minutes. The ease with which the candida and mycelia of moniliasis or bacteria such as the coccobacilli of *Haemophilus influenzae* meningitis may be seen, lends strong support to the routine use of methylene blue film.

#### *Carbol Fuchsin Stain*

Dilute carbol fuchsin (10% aqueous solution of concentrated carbol fuchsin, see Ziehl-Neelsen method below) is used in a similar fashion to methylene blue as described above. In a suitably purpuric fevered child a smear of ‘juice’ from a purpuric blob pricked with a needle, or the buffy layer of cells on centrifugation of blood may be stained after fixation to show diplococci of the *Neisseria meningitidis* type with a duplex rather than lanceolate (pneumococcal) appearance. This immediately suggests meningococcal septicaemia and mandates parenteral antimicrobial treatment whilst Gram’s stains, culture and other procedures continue.

Ziehl-Neelsen method: Concentrated carbol fuchsin (1 g basic fuchsin in 10 ml absolute alcohol made up with 100 ml,

5% aqueous phenol) is the basis of Ziehl-Neelsen method used for mycobacterium tuberculosis and other mycobacteria. This is a rather complex procedure but one which may be applied to sputum, centrifuged fasting gastric juice, pus from a cold abscess or sinus or to CSF. The concentrated carbol fuchsin solution is applied and the slide warmed a number of times until the stain begins to steam. It must not be allowed to evaporate. After 5 minutes the solution is poured off, the slide washed in water and then immersed in 20% sulphuric acid for 1 minute, the slide is washed and the acid application and washing repeated several times until the film is only faintly pink. After the acid is washed off and the slide washed in water, 95% alcohol is applied for 2 minutes. These last two steps may be combined by the use of acid-alcohol (3.0% hydrochloric acid in absolute alcohol) until the smear is faintly pink. The film is examined for red acid and alcohol-fast *M. tuberculosis*. It may be counterstained with methylene blue for 1 minute to give a colour contrast. The findings of such acid and alcohol fast bacilli are highly suggestive of *M. tuberculosis* but not specific without more sophisticated techniques or even culture.

### Gram's Stain

There are many modifications of this staining procedure. Advice on the staining technique should be obtained locally and the necessary solutions made available in the ward test room.

1. Stain with methyl violet 6B or crystal violet (0.5% in distilled water) for 30 seconds. This solution of stain should be filtered immediately before use.
2. Pour off excess of stain, hold the slide on a slope and wash away excess stain with Gram's iodine (1 g iodine, 2 g potassium iodine and 300 ml distilled water).
3. Wash iodine off with absolute alcohol and repeat until colour ceases to come out of the preparation.
4. The slide is washed with water for 1 minute.
5. Apply a suitable counter stain such as dilute carbol fuchsin (10% aqueous solution) for 1–2 minutes.

This stain is particularly important in dealing with CSF. The gram positive lanceolate and encapsulated diplococcus of *Streptococcus pneumoniae* (pneumococcus) are sharply differentiated from the duplex pattern of gram negative *N. meningitidis*. The most awkward problem is with *Haemophilus influenzae* which is gram negative and pleomorphic and gram negative rods of *E. coli* (Figs 38.14 and 38.15).

However, polymerase chain reaction (PCR) is an emerging technology that is based on the ability to detect DNA of pathogens, living or dead. The advantages of PCR testing include rapidly available results, often within hours, and the detection of organisms even if they have been killed by prior antimicrobial administration.

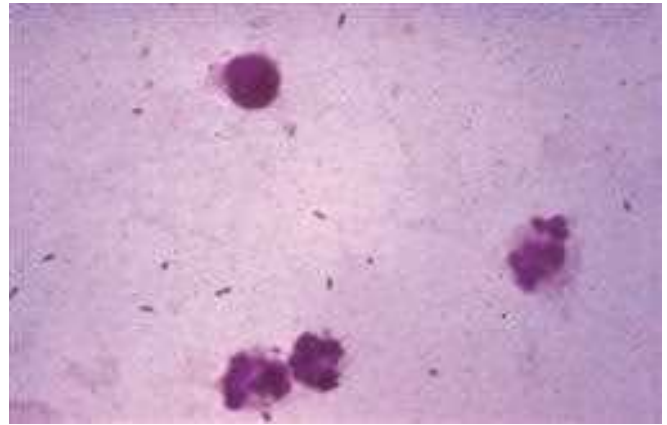


Fig. 38.14: Cerebrospinal fluid with pus cells and *H. influenzae*

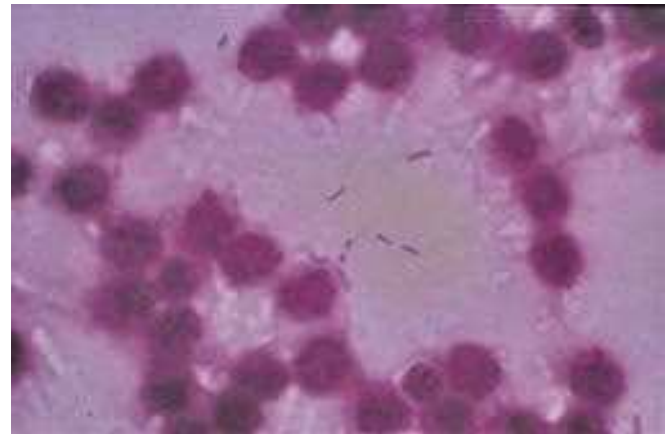


Fig. 38.15: Cerebrospinal fluid with pus cells and *E. coli*

## Central Nervous System

### Transillumination

This simple and safe method of examination of the infant head is too often neglected. A case can be made for its routine use in the neurological examination of an infant during the first year of life, and in selected cases at later age. Careful technique is essential. The infant is taken into a totally blacked-out room. The examiner uses a strong torch fitted with a black rubber adapter which prevents the escape of stray light when it is pressed against a flat or convex surface. He begins by testing his own dark adaption by attempting to transilluminate the palm of his hand. The infant's head is then systematically explored by switching on the torch when it is pressed against the frontal, central and occipital regions on each side, and also in the midline posteriorly over the posterior fossa. Normally there is a narrow rim of transillumination around the adapter, the precise diameter of which depends on the characteristics of the light employed. The rim is greater in the frontal regions, and is inversely related to age. Abnormalities include generalised transillumination in hydranencephaly or

aqueduct stenosis, unilateral increases in subdural effusion or porencephaly, posterior fossa glow in the Dandy-Walker syndrome or some arachnoid cysts, and multiple illuminated regions in cystic encephalomalacia (Fig. 38.16). Suspected abnormalities may sometimes be more precisely defined by directing the light serially through them from more than one direction. The findings could be confirmed by cranial ultrasound.

### Lumbar Puncture (Spinal-Tap)

This is most commonly carried out to determine whether meningitis is present. The technique is easier for the operator and much to be for the child if sedation is used sufficient to induce amnesia. Most operators prefer the lateral decubitus position, with the child's knees held in a flexed position near his face (Fig. 38.17). It is wise to ensure that an experienced assistant is able to hold a flexed infant firmly immobile before beginning the LP proper otherwise struggling may spoil the procedure at a critical moment should the sedation

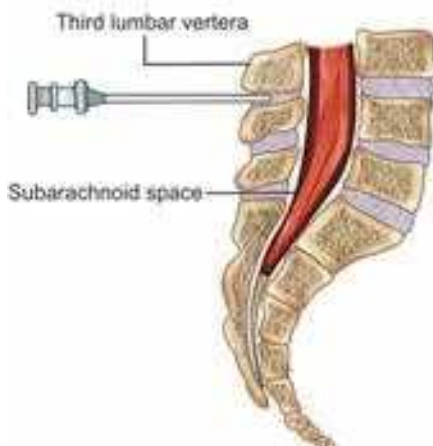


**Fig. 38.16:** Positive transillumination in an infant with hydranencephaly. The entire head "lights up" in hydranencephaly

prove inadequate. After skin preparation (2% iodine in 70% ethanol is effective) local anaesthetic such as 1% lignocaine may be infiltrated at the chosen site between the second and third lumbar spines. This level is approximately indicated by a line joining the superior iliac crests. Many omit the local anaesthetic for rapid punctures not involving pressure measurements. A short fine LP needle with a stillete (for instance, a No. 22 needle which has a very short bevel) is pushed through the skin and then slowly advanced anteriorly and very slightly cephalad with a slight rotator motion until a barely felt click sensed through the tips of the index finger and thumb signals the penetration of the ligamentum flavum and dura mater. In small children the first appearance of CSF is less likely to be missed if the stillete is withdrawn after the skin has been punctured and reinserted briefly from time to time with each small movement deeper. Otherwise the narrow subarachnoid space may be crossed unwittingly, the anterior plexus of veins transfixied, and a bloody tap result. The use of a small (No. 23) butterfly scalp-vein needle with its attached tubing has been advocated for LP in the newborn to reduce the chance of such a 'bloody tap' but there is a small risk of implantation spinal epidermoid tumours and leading to paraparesis some years later if a needle without a stillete is used to penetrate the skin.

### Equipment Required

- Spinal or LP tray (including the items listed below)
- Sterile gloves
- Antiseptic solution with skin swabs
- Sterile draps
- Lidocaine 1% without epinephrine
- Syringe 5 ml and 10 ml
- Needles 20 gauge and 25 gauge
- Spinal needles 20 gauge and 22 gauge
- 3-way stopcock



**Fig. 38.17:** Lumbar puncture child in the lateral recumbent position

- Manometer
- Four plastic test tubes or universal containers
- Sterile dressing.

#### Key Learning Point

##### Lumbar puncture needle without stilette

- The LP needles must contain stilettes to avoid the possibility of inducing implantation dermoids and leading to paraparesis some years later.

#### Key Learning Points

##### Contraindications to lumbar puncture

- Suspicion of an intracranial or spinal mass lesion
- Raised intracranial pressure
- Brain swelling
- Obstructive hydrocephalus
- Congenital lesions in the lumbosacral region (e.g. meningomyelocele)
- Platelet count below  $40 \times 10^9/L$  and other clotting abnormalities.

Some CSF is allowed to drip into sterile centrifuge tubes and a few drops added to 5 ml of dilute (15%) phenol solution in water in a test tube for Pandy test. Cloudiness appearing when the CSF is added to the phenolic solution indicates an excess of globulin. Any cloudiness in untreated CSF means an increased cell count. Xanthochromia may be obvious in clear CSF. If the CSF is bloody and a streaming effect from a punctured vein is not obvious, traditionally three tubes of CSF are taken to be compared, and later centrifuged to look for xanthochromia in the supernatant fluid. Xanthochromia of the supernatant may reflect bleeding several hours previously. It must be admitted that the distinction cannot always be made with certainty. This underlines the need for good positioning and assistance with great care to avoid such a traumatic bloody tap. In circumstances where measurement of the pressure is important a spinal manometer is attached as soon as CSF is seen to flow. It is a common fallacy that the pressure can be guessed by watching the rate of flow from the needle; it cannot, and a few trials with the manometer will soon convince the sceptic. The normal CSF pressure in a neonate is in the range 0–5.7 mm Hg (0–7.6 cm H<sub>2</sub>O). The upper limit of the CSF pressure in older children is said to be similar to the adult value of 14 mm Hg (19 cm H<sub>2</sub>O). The protein in the CSF consists mostly of albumin and immunoglobulins. The normal protein concentration may be over 1 g/L in the newborn, but it then falls to low levels, with an upper limit of about 200 mg/L later in infancy with only a gradual increase towards the adult upper limit of 400 mg/L throughout childhood. Interpretation of the glucose

concentration depends on the level of the blood glucose, which should ideally be measured at the same time. The cell count should also be determined and a methylene blue and Gram stain made from some of the centrifuged deposit. CSF should always be sent to the microbiological and biochemical departments.

#### Key Learning Point

##### Complications of lumbar puncture

- Infection, leakage of CSF, headache, nausea, vomiting, signs of meningeal irritation occur in approximately 25% of children.

### Subdural Puncture (Subdural-Tap)

This is carried out for the diagnosis and treatment of subdural haematoma or effusion. It is sufficiently safe to be recommended at an early stage when such a condition is suspected, provided that it is remembered that it is not entirely without risk. It is usually carried out by a neurosurgeon whilst the patient is anaesthetised. Haemorrhage and persisting effusion may be induced and if the brain is punctured the possible complications are similar to those described under ventriculography. Infection including the very serious subdural empyema is possible if technique is grossly lax.

The site of puncture is the lateral angle of a large anterior fontanelle or just lateral to it (in the coronal suture) if it is small. After shaving, preparation of the skin with 2% iodine in 70% ethanol and draping with the infant securely held supine, the skin is displaced and punctured by a fine short bevelled needle (No. 22, 3.8 cm long) with a stilette before being released into its normal position. This Z-track technique reduces the likelihood of continued fluid leakage and infection later. The needle is then advanced caudally, laterally and obliquely until a 'give' is felt as the skull is penetrated. It should then be advanced not more than 2 or 3 mm with the stilette withdrawn. Normally no advance of the needle is necessary. If a few drops (sometimes more) of clear fluid are obtained it is likely that the subarachnoid space has been traversed and that one is sampling subarachnoid CSF. This will have protein content higher than lumbar CSF but not the very high concentration characteristic of subdural effusions.

If subdural fluid is encountered (proteinaceous, cloudy, yellow, brown or red) it is allowed to drain into a centrifuge tube or test tube, removing a maximum of 20–40 ml (Fig. 38.18). Large quantities of CSF should not be aspirated with a syringe. Firm pressure is applied with a cotton wool ball after the needle has been withdrawn. Some operators put a silk suture around the skin puncture, but this should not be required with the technique described. Whether or not the diagnostic tap is negative or positive it is always repeated on the other side. After any such subdural puncture there





**Fig. 38.18:** Xanthochromic subdural fluid from an infant who had subdural haemorrhage

is commonly some seepage of CSF under the scalp and so transillumination becomes falsely positive.

### Ventricular Puncture

This procedure is used to obtain CSF in suspected ventriculitis when the lumbar route cannot be used, to introduce air for ventriculography and for emergency decompression when the intracranial pressure is dangerously high due to obstruction to outflow from the ventricular system. While it may be life-saving in the latter situation, it should not be thought of as harmless. If the ventricular pressure becomes or remains high after the procedure, cystic expansion may occur along the needle track with associated brain atrophy. Porencephaly may result. Induced bleeding into the ventricular system is sometimes fatal; on other occasions the intraventricular haematoma can be demonstrated by contrast radiography or cranial CT. Such remarks serve as a reminder that ventricular puncture is ideally a neurosurgical procedure and should not be used lightly.

Commonly the right lateral ventricle is chosen for entry to avoid damage to the presumptive speech-dominant hemisphere. The head is prepared as for subdural tap, but after the same valvular approach through the skin at the same site the needle is advanced at right angles to the tangent of the skull at its point of entry. A fine LP needle with stilette is commonly used although neurosurgeons would prefer a method employing the use of a proper brain needle. It is likely that CSF will be reached at a depth of 3 cm or less, for unless the ventricle is dilated the procedure is seldom indicated or indeed likely of success. It is not usually possible to detect by feel the entry of the needle into the

ventricle, so the stilette must be withdrawn to see whether CSF escapes.

### The Urinary Tract

#### *Suprapubic Aspiration (Bladder-Tap)*

The suprapubic aspiration is a very safe procedure to obtain urine from the newborn and infants under 2 years of age, because the distended bladder in this age group is primarily intra-abdominal. For this procedure to be successful it is essential that the bladder is full. Dehydration reduces the success. Ultrasonographic confirmation of the bladder would be helpful. The site of the needle puncture is 2 cm above the symphysis pubis.

#### *Procedure*

The procedure is as follows:

- Cleanse the suprapubic area with betadine (povidone-iodine)
- Locate the pubic bone
- Insert a one inch 22 gauge needle attached to a 5 ml syringe at midline, angling the needle 10–20 degrees cephalad and pushing it through the skin under negative pressure at all times
- Entry into the bladder is indicated by return of urine.

#### *Complications*

- Although complications are rare but include haematuria, anterior abdominal wall abscess and bowel puncture. Peritonitis is uncommon.

### Percutaneous Renal Biopsy

#### *Procedure and Complications*

Percutaneous renal biopsy has been commonly used since 1954. It is tricky and requires deft fingers. It should not be undertaken without instruction from an expert paediatric nephrologist. It is usually performed under general anaesthetic. Two specimens containing cortical tissue are generally required to obtain adequate material for light: (1) immunofluorescence and (2) electron microscopy.

Prior to renal biopsy the following investigations are advised:

- Check haemoglobin level, platelet count and coagulation screen
- Real-time ultrasound control is optimal
- Ensure, adequate monitoring of the patient, including continuous pulse oximeter, recording during and following procedure
- Biopsy is usually done with sedation and under a local anaesthetic, but in some cases it may be performed under a general anaesthetic

- Ensure sedation and analgesia has adequate time to take effect prior to commencing procedure
- Ensure EMLA cream is applied to the biopsy site at least 90 minutes prior to the procedure
- The kidneys lie on either side of the spine just below the muscles of the back. The technique involves inserting a needle down through the back muscles and into the kidney (usually the left), and the removal of some very small pieces of kidney
- An ultrasound scanning machine is used during procedure to ensure the correct positioning of the needle
- Ensure adequate resuscitation equipment is readily available
- Aim to biopsy the lower pole of left kidney (unless contraindicated); ensure biopsy is away from vessels
- Position patient prone (supine for transplanted kidney)
- Generally use 16G needles (18G for transplant biopsies)
- Following procedure monitor vital signs.

After the biopsy the blood pressure and pulse rate are monitored closely, the urine is tested, and the patient is kept in bed for at least 6 hours. There may occasionally also be some bleeding around the kidney or blood in the urine. Once fully awake after the renal biopsy, the patient is encouraged to drink fluids to help flush away blood from the kidney. Vigorous activity is discouraged for 1 week after the biopsy. Similar procedure is carried out to biopsy a transplanted kidney.

When it is considered that percutaneous renal biopsy involves, an undue risk, an open surgical renal biopsy can be considered. This technique always provides an adequate specimen of the renal cortex.

## Renal Biopsy

### Indications

- Atypical nephrotic syndrome
- Persistent hypocomplementaemia and nephritis
- Acute nephritis not resolved in 1 month
- Anaphylactoid nephritis not resolved in 1 month
- Persistent undiagnosed haematuria
- Persistent undiagnosed proteinuria
- Persistent undiagnosed renal failure.

### Contraindications

May be as follows, none absolute in a desperate situation:

- Single kidney
- Hydronephrosis
- Systemic hypertension
- Uraemia
- Haemorrhagic diathesis.

## Respiratory System

### Pleural Aspiration

Aspiration of a pleural effusion may be indicated for diagnostic or therapeutic reasons. It is an unpleasant procedure and in most instances the child should be sedated. In all instances local anaesthesia should be used. The infant or child should preferably be seated on a firm surface sitting upright with his arms placed forward over pillows. Sufficient pillows should be employed to make his back as nearly perpendicular as possible. Standard aseptic technique is employed. The optimal site can be identified by US.

When the effusion is large the site of entry is in the sixth intercostals space in the scapular line. When the effusion is localised, as indicated by clinical and radiological examination, the site of entry is best made over the area of maximum dullness on percussion.

A large bore needle or suitably sized trocar (12–18 gauge: 7.5 cm length) is employed: if thick pus is expected then a wide bore instrument is essential. A bone-marrow aspiration needle may be very useful in tapping a thick empyema. A suitable size syringe and 2-way tap is attached to the needle before the skin puncture—a length of plastic tubing should lead from the side arm of the tap to a receptacle for collecting the aspirate. Sterile containers for bacteriological specimens should be to hand.

The needle is inserted in the sixth intercostal space just above the seventh rib and slowly advanced in a forward and slightly medial direction. If slight negative pressure is maintained on the syringe then fluid will be drawn off as soon as the effusion is entered. If much fluid is to be withdrawn, aspiration should be performed fairly slowly. Antibiotics may be instilled if indicated at completion of aspiration before the needle is withdrawn. The site of the puncture may be covered with a sterile swab to avoid leakage from the wound. Repeated aspiration may be performed in this manner though it is best not to use precisely the same puncture wound each time.

If drainage of a tension pneumothorax is required then the tense gas should be released slowly through polyvinyl tubing which is left in situ and connected with an underwater seal drain. Care should be taken to ensure that no fluid can return through the tubing into the chest by positioning the bottle well below the level of the patient.

## Bronchoscopy

Bronchoscopy may be an elective or an emergency procedure. Flexible bronchoscopy is used for diagnostic purposes and obtaining broncho-alveolar samples. Removal of foreign bodies requires rigid bronchoscopy. In either case it is performed under general anaesthetic with the use

of a short-term muscle-relaxing agent. Prior to the elective procedure the patient should not be given anything to eat or drink for a period of at least 4 hours. In the emergency situation, the stomach contents should be removed as far as possible by aspiration through a wide-bore nasogastric tube before anaesthesia is required.

A bronchoscope of a size suitable for the child is chosen. Following induction of anaesthesia the bronchoscope is inserted, with the patient's neck and head fully extended. The maintenance of respiration during the procedure is usually constant or intermittent via the side arm of the bronchoscope. Suction may be used to extract suitable foreign bodies such as a disintegrating peanut but expertise is required for even this moderately simple manoeuvre and certainly for any more complex.

### Tracheostomy

Tracheostomy may be either an elective or an emergency procedure. It should be performed under general anaesthesia in an operating theatre if possible but in the emergency situation an asphyxiated patient who is unconscious and deeply cyanosed does not require the former and usually cannot wait for the latter.

The trachea is intubated with the patient's neck fully extended. The cartilages of the third and fourth tracheal rings are located by palpation and a midline vertical incision is made through them. A tracheostomy tube of suitable size for the patient (it should fit snugly but not tightly to avoid pressure necrosis of the tracheal mucosa) is selected and inserted. The tracheostomy tube is fixed firmly but not tightly in place by the use of tapes attached to its lateral flanges and tied around the neck. Maintenance care of the tracheostomy must be constant to keep it clear. Initially the patient should be observed for evidence of complications consequent to the procedure, e.g. haemorrhage or pneumothorax. Throughout its period of use in the emergency situation care must be taken, that bronchial secretions do not dry within and therefore block the tube. This is avoided by ensuring high humidity of inspired air.

The trachea and bronchi should be aspirated of secretions at frequent regular intervals with sterile technique—it may be helpful to instil 1–2 ml warm sterile saline into the tube prior to aspiration if secretions are particularly viscid. The skin around the tracheostomy wound should be carefully cleansed and dressed (with sterile gauze swab or sterile vaseline gauze) to avoid its becoming infected.

The decision to remove the tracheostomy tube permanently depends on a number of factors including the reason for its initial insertion and the patient's ability to maintain adequate ventilation without it. The orifice of the tube may be partially

blocked by gauze swab to encourage oral and nasal breathing and then closed completely, but intermittently, for short periods. Once the tube may be dispensed with the neck wound is covered with sterile dressings until healing has occurred.

#### Key Learning Point

##### Tracheostomy

- ➔ In gross emergency before formal tracheostomy is performed, insertion of a wide-bore short bevel needle into the trachea may be life-saving.

Indications of tracheostomy are given in Box 38.1.

#### Box 38.1: Tracheostomy indications

- Upper airway obstruction
- Angioneurotic oedema, anaphylaxis (if conventional airway management has failed)
- Prolonged endotracheal tube requirement
- Vocal cord paralysis
- Choanal atresia
- Subglottic stenosis
- Assisted ventilation and pulmonary toilet
- And others.

### Laryngoscopy

This manoeuvre may be required for viewing the larynx directly, e.g. as a diagnostic procedure or for removing foreign material and is an integral part of endotracheal intubation. General anaesthesia is required in all cases except the cardiac arrest situation.

#### Requirements

- A functioning laryngoscope with a blade straight or curved as appropriate to the patient's size
- A well-lit room
- Full monitoring.

The patient is laid supine on a firm flat surface. The operator positions himself at the patient's head with his eyes level with the head. The patient's neck is fully extended. The laryngoscope handle is grasped dagger fashion and the blade inserted along the side of the mouth and pushed back to the root of the tongue: it is then positioned centrally so that its point is towards the oesophagus and the tongue is held firmly beneath the blade. By pronating the hand holding the handle of the laryngoscope the point of the blade is made to pass anteriorly and the operator views the oesophageal orifice and then the larynx. Gentle elevation of the tip of the blade allows the point to slip between the epiglottis and the root of the tongue. By lifting the laryngoscope forward an adequate view of the larynx is now obtained.

### *Endotracheal Intubation*

In emergency situations such as cardiac arrest, intubation is performed without sedation or anaesthesia—the elective procedure is always performed under general anaesthetic. Intubation may be performed via the mouth or via the nose. The former route is simpler and is the method of choice where intubation is likely to be temporary—the nasal route offers greater stability for the tube.

## **Cardiovascular System**

### *Pericardial Paracentesis*

Accumulation of fluid in the pericardial space of sufficient quantity to cause cardiac embarrassment and necessitate aspiration is rare in the paediatric age group.

Pericardiocentesis may be required as a diagnostic procedure, e.g. in purulent pericarditis or therapeutically as for instillation of appropriate antibiotics, or as an emergency procedure in haemorrhagic tamponade.

The decision to use sedation should rest with the operator and his assessment of the condition of the patient: it should probably be used in most instances unless the child is collapsed. Ultrasonographic monitoring during the procedure is advised.

The infant should be laid supine: the older child may have a pillow as a head rest. Local anaesthesia should be used in all instances. A wide-bore needle (12–18 gauge, 7.5 cm, short bevel) may be used. Full aseptic technique is employed. The usual site of entry is the angle between the left costal margin and the xiphoid process whence the needle should be directed upwards, backwards and to the left. An alternative approach is via the fifth left intercostal space anteriorly, 2 cm within the area of cardiac dullness, with the needle pointed slightly upwards and medially. The needle should be advanced cautiously and may be felt to penetrate the pericardium usually at a distance of 2–4 cm from the skin surface. If a diagnostic tap only is required a 5 ml volume syringe should be firmly attached to the needle before insertion.

In most instances it is best to attach a 2-way tap to the needle especially if the effusion is large or if antibiotics are to be instilled; the tap also helps to avoid the introduction of air. If the effusion is large aspiration should be performed with careful observation of the patient's condition.

## **Exchange Transfusion**

### *Equipment Required*

- Sterile equipment
- Polyvinyl catheter for the umbilical vein (No. 6 or 9)
- Two 2-way taps

- Four (at least) 10 ml (disposable) syringes
- Donor set
- Catheter to connect to receive or plastic bag for the reject blood
- Umbilical vein marker
- Calcium gluconate—10% and sodium bicarbonate—8.4%
- Scissors, mosquito forceps and towel clips
- Gown and drapes
- Fresh blood compatible with the baby and cross-matched against the mother's serum. Prepacked sets of disposable equipment are available.

### *Preparation*

A preterm, or ill infant, should have his acid-base state measured and any metabolic acidosis corrected by intravenous sodium bicarbonate. Gastric contents are aspirated. Oxygen, suction and a good light are essential. Sterile towels are positioned, leaving the abdomen and chest clear. If the infant is small or ill, the procedure may be done within an incubator, otherwise in a baby-warmer or under a phototherapy unit.

### *Procedure*

There are several techniques utilised for this procedure so it is important to use that which is traditional for the locality. These include using simultaneously, arterial and venous catheters. The technique described is based on the original method.

The cord is cut 2 cm from the skin junction and the edge gripped with mosquito forceps. The catheter is advanced into the vein until a free flow of blood is obtained, and is then attached via the two 2-way taps to a 10 ml syringe. The donor blood set is attached to one side arm and the reject catheter to the other.

Initially ten millilitres of blood are withdrawn and disposed of or sent for biochemistry, the syringe is then filled with 10 ml donor blood which is slowly injected—taking 1–2 minutes. The aliquot volume can be slowly increased as tolerated to a maximum of 20 ml in a term infant. This cycle is repeated until the desired volume has been exchanged (150 ml/kg). The attendant charts the quantities of blood flowing in and out and observes the infant's condition closely. Evacuated blood may be measured in a suitable cylinder.

In most centres, citrate-phosphate-dextrose (CPD) blood is used in which case no additional drugs are necessary. If acid-citrate-dextrose (ACD) blood is being given then 2 ml of 4.2% sodium bicarbonate is given at the same time, but only during a first exchange transfusion. (This is not required during subsequent exchanges since the citrate will be metabolised).

At the end of any exchange, the catheter is left in situ until the need for further exchange has passed.

## Alimentary System

### Endoscopy

Endoscopy is one of the most important technical advances in paediatric medicine. Endoscopy is of help as a diagnostic tool, particularly when used in conjunction with cytology or biopsy. There are mainly two types of endoscopes: (1) rigid and (2) flexible. The rigid type of instruments are usually more basic in design, e.g. proctoscope, sigmoidoscope. Rigid bronchoscopes and oesophagoscopes are now rarely used.

The modern flexible endoscopes are used in the investigations of upper GI endoscopy, sigmoidoscopy, colonoscopy, bronchoscopy and arthroscopy. Because endoscopy can be physically and emotionally unpleasant for the child, most of these procedures are performed under general anaesthetic. Diagnostic endoscopy is usually a very safe procedure provided the endoscopist is well trained.

### Paracentesis Abdominis

This may be required for diagnostic or therapeutic reasons. Diagnostic puncture may be required to ascertain the nature of the fluid causing ascites or more usually to define whether peritonitis is present and to recover the organism. It requires no sedation or local anaesthetic unless the child is exceptionally restless. The skin is cleaned with 2% iodine in 70% ethanol.

An intravenous needle or short plastic cannula is inserted in the midline, midway between the symphysis pubis and the umbilicus if ascites is gross, and in the flank at the level of the umbilicus if it is less gross. The area into which the needle is being introduced will be dull and care should be taken to avoid an enlarged liver, spleen or bladder. Fluid is withdrawn and investigated for organisms and cytology, by culture or biochemically as indicated. The iodine remaining is cleaned off the skin with 70% ethanol.

Today the removal of ascetic fluid by mechanical means is rarely required, attention being given to the medical treatment of the primary cause. If required the usual practice is to proceed as follows after sedating the child.

#### Procedure

- Clean up an area of skin in the midline between the umbilicus and symphysis pubis or lateral to the umbilicus. Apply 2% iodine in 70% alcohol. Make sure the bladder is empty or nearly so.
- An area of skin is infiltrated with 1% lignocaine subcutaneously. The tissues of the abdominal wall down to the peritoneum are similarly treated.
- A small nick is made in the skin with a scalpel blade.

- A disposable peritoneal dialysis polyvinyl tube is introduced through the skin, subcutaneous tissue, muscles and peritoneum, using the introducer provided. The tube is inserted for approximately 15 cm further until all the perforated tube is in the peritoneal space.
- Alternatively a small trocar and cannula may be used. These are inserted through the peritoneum and the removal of the trocar enables fluid to gush out. The fluid flow should be controlled to allow the abdomen to empty over a period of 15–30 minutes.
- When the desired amount of fluid has been withdrawn and no more is available, and then the tube (or cannula) is withdrawn. If the tension of the ascites has been removed it should be possible to bring the edges of the hole into apposition by a strip of plaster. If not it may be necessary to apply a cutaneous suture or clip.
- The remaining iodine should be cleaned off the skin with 70% ethanol.

### Percutaneous Liver Biopsy

This is only performed by skilled, experienced operators under general anaesthetic. A coagulation profile and blood crossmatch should be performed prior to the procedure and any clotting abnormalities corrected. Histological examination of liver tissue usually provides vital information for the management of the child with liver disease, giving evidence which is not present by other means. Also the liver biopsy can provide material for bacterial and viral culture, analysis of enzyme activity, chemical content as well as histological IM and EM studies. The technique of liver biopsy does carry a slight but definite morbidity and also mortality. However, ultrasonography directed biopsies may increase the yield of meaningful results.

### Jejunal Biopsy (Biopsy of Small Bowel Mucosa)

Small intestinal mucosal biopsies are important in the evaluation of children with malabsorption. A normal biopsy in these children may be as useful as an abnormal biopsy because it would direct diagnostic approach elsewhere. Most jejunal biopsies are obtained by endoscopy under general anaesthetic.

There are several kinds of biopsy tubes available, e.g. the Shiner flexible biopsy tube, the Rubin biopsy tube and the Crosby capsule. The Crosby capsule is the most appropriate for everyday use. A child-size capsule is available for use in infants and small children.

#### Procedure

- The capsule must be thoroughly checked prior to use.
- Child must fast overnight, and most do not require a local anaesthetic.

- The capsule is placed on the back of the tongue and if the child sits upright, it can be swallowed without any difficulty.
- The length of tubing required to allow the capsule to enter the gastric antrum should be estimated and marked.
- When this is achieved, the gastric peristalsis is encouraged by gently injecting air down the apparatus while the child lies in the right lateral position.
- The efflux of bile-stained fluid indicates the entry of the capsule into the duodenum.
- At this stage the child is turned into the supine position and asked to swallow another foot of tubing.
- At the end of 3 hours the position of the capsule must be confirmed radiologically.
- When the capsule has reached the jejunum it can then be fired by applying forceful suction from a 20 ml syringe to ensure the knife is released.
- The capsule is withdrawn and opened. The tissue obtained is then fixed in formol saline and sent for microscopical examination.

#### Key Learning Point

##### Jejunal biopsy

- ⇒ The small bowel biopsy specimen is diagnostic of coeliac disease and is regarded as the 'gold standard' although errors occur especially with poorly orientated specimens.

### Urea Breath Test (*Helicobacter Pylori* Infections)

The urea breath test is a non-invasive test used to detect the presence of *H. pylori* in the stomach, and is the simplest way to confirm eradication of infection after treatment. The test is based on the capacity of *H. pylori* to secrete the enzyme urease, which hydrolyses urea to ammonia and carbon dioxide. When a dose of urea labelled with a non-radioactive isotope of carbon ( $^{13}\text{C}$ ) is taken by mouth, the label appears in breath carbon dioxide if the child has gastric *H. pylori* colonisation. The accuracy of the urea breath test may be reduced if the child is currently receiving or has recently completed treatment with antibiotics, proton-pump inhibitors, or  $\text{H}_2$  receptor antagonists.

The abundance of  $^{13}\text{C}$  in breath  $\text{CO}_2$  is measured by continuous-flow isotope ratio mass spectrometry [20-20 Automated Breath  $^{13}\text{C}$  Carbon Analyser (ABCA), Sercon, Crewe, UK] against international standards. The enrichment of the post-dose sample is calculated by subtracting the abundance of the baseline sample from that of the post-dose sample.

A test is considered positive if the enrichment of the post-dose sample is greater than or equal to 40 parts per million  $^{13}\text{C}$  ( $\geq 40 \text{ ppm } ^{13}\text{C}$  excess) and delta above baseline ( $\geq 3.5 \text{ ppm } ^{13}\text{C}$  excess).

Also there are no specific endoscopic features of *H. pylori* infection. Histological assessment of an endoscopic antral biopsy is a reliable means of detecting *H. pylori*, but requires expertise and the result is not immediately available. Culture of endoscopic biopsies is equally sensitive and specific but suffers similar drawbacks.

#### Key Learning Points

##### Urea breath test

- ⇒ Proton-pump inhibitors should be stopped 2 weeks before the test.
- ⇒  $\text{H}_2$  receptor antagonists should not be taken on the day of the test.
- ⇒ Antibiotics should have been stopped for at least 4 weeks.

### Twenty-Four Hour Oesophageal pH Monitoring (Regurgitation, Gastro-Oesophageal Reflux, Gastro-Oesophageal Reflux Disease)

Gastro-oesophageal reflux (GOR) is a very common occurrence in children but its clinical importance varies vastly upon the age of the child. It is worth remembering that the terminology, e.g. regurgitation, GOR and gastro-oesophageal reflux disease (GORD) can easily be confused in paediatric practice. Regurgitation of gastric contents into oesophageal lumen is much more frequent in infants and most likely a physiologic event and largely self limited in the majority. Interestingly reflux of gastric contents in the oesophagus is almost always acidic in adults, but it is frequently not the case in young children, infants and particularly in premature infants. On the contrary, GORD refers to pathologically frequent or severe acidic gastric reflux associated with mucosal damage and/or symptoms and complications. Therefore, it is important to identify children with significant GOR and to treat them as GORD.

#### Procedure

Although the test can be carried out at home, but some infants and children may need to remain in the hospital for the test. Some drugs (e.g. antacids, corticosteroids,  $\text{H}_2$  blockers, proton-pump inhibitors) may change the test results. So they have to be stopped 24 hours to weeks before the test.

#### Key Learning Point

- ⇒ 24-hour oesophageal pH-metry has been one of the main diagnostic tools used for the diagnosis of GORD. The test measures how often and for how long stomach acid enters the lumen of the oesophagus.

A thin tube with a probe is passed through the nose into the stomach. Then it is pulled up into the oesophagus. The

tube is attached to a monitor that measures the level of acidity in the oesophagus.

The parents of the child will keep a note of the symptoms over the next 24 hours. The next day the tube will be removed. The information from the monitor will be compared with symptoms record kept.

Acid reflux is defined whenever the pH in the oesophagus drops to 4 or less. The tracing is read by counting the number of reflux episodes and measuring the duration of each reflux episode in minutes (Figs 38.19 and 38.20).

### Percutaneous Endoscopic Gastrostomy

Percutaneous endoscopic gastrostomy (PEG) is designed to establish an artificial tract between the stomach and the abdominal surface and is usually used for long-term enteral support. There are catheters which are specifically designed for children for this purpose and should, therefore, be used. Before the establishment of the gastrostomy feeding tube, a full assessment of the child and the family should be carried out to ascertain their ability to manage the tube. Also the parents should have the full risks and benefits of placing the tube explained. Tract formation occurs within a few

hours and it is safe to commence feeding 4 hours after tube insertion. The main contraindications are severe obesity, portal hypertension and coagulation abnormalities.

Complications of PEG are given in Box 38.2.

#### Box 38.2: Complications of PEG

- Skin problems due to leakage from the gastrostomy site
- Pneumoperitoneum and subcutaneous emphysema
- Peritonitis (rare)
- Gastrointestinal haemorrhage (rare)
- Gastric outlet obstruction and/or duodenal obstruction
- Tube occlusion (frequent)
- GOR (during gastrostomy feedings)

### Skin

The diagnosis of skin disorders in children is usually on the distribution and characteristics of the lesion or rash. However, histological examination is necessary for final confirmation of a diagnosis when there is doubt on clinical grounds. It is vital to provide adequate piece of skin for interpretation, which usually means a full-thickness (epidermis, dermis and a small amount of subcutaneous tissue) biopsy through the edge of the lesion.

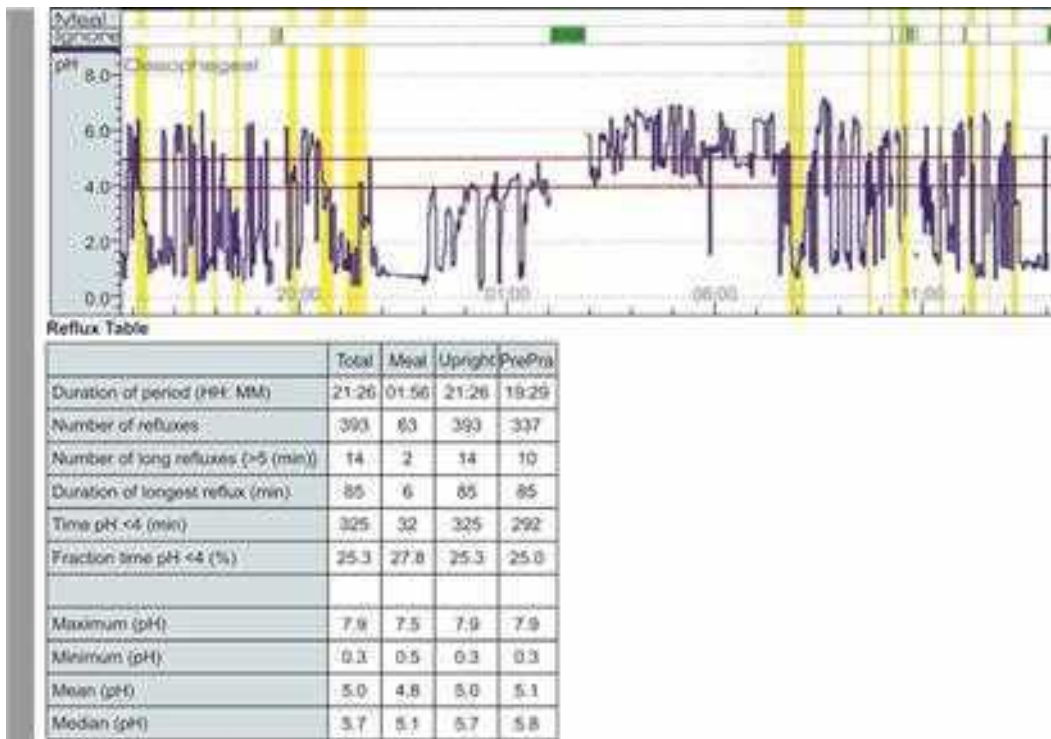


Fig. 38.19: Tracing of oesophageal pH monitoring of a child over one year old % <math>pH<4>5\%</math>. Showing significant GOR, i.e. GORD

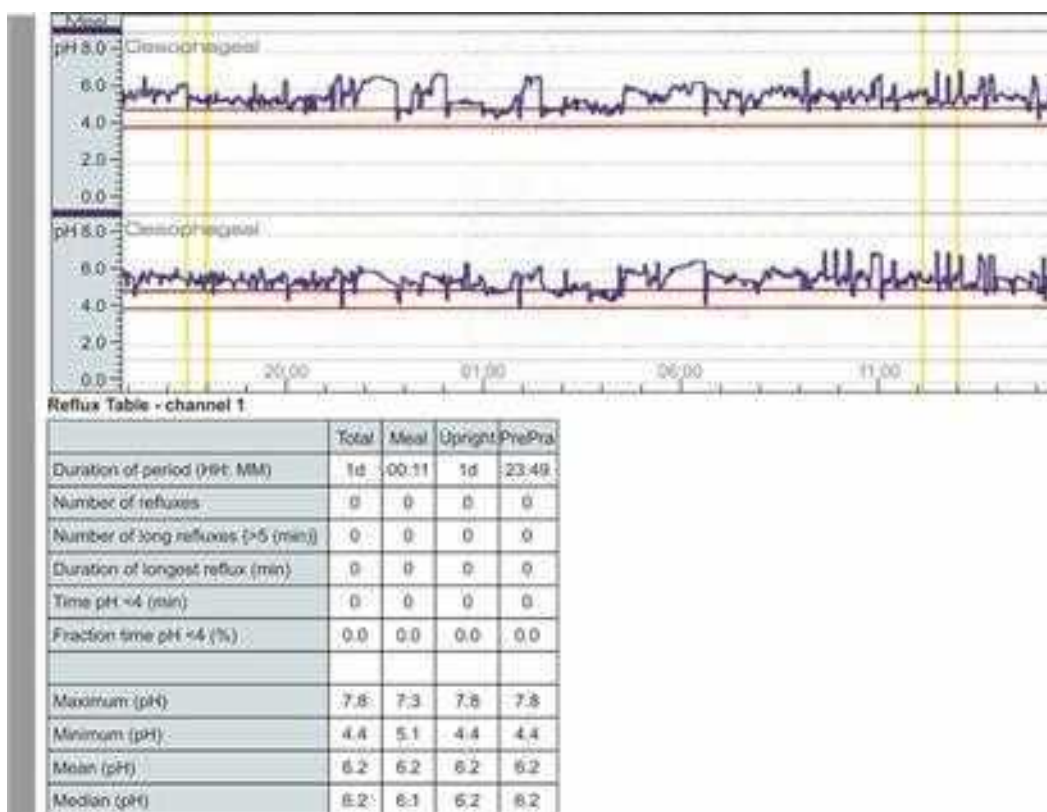


Fig. 38.20: Tracing of oesophageal pH monitoring, post-fundoplication showing no GOR

### Mantoux Test

Tuberculin skin tests are, of all tests, the most useful in the diagnosis of primary tuberculosis. In the Mantoux test—the diagnostic is given by intradermal injection of tuberculin purified protein derivative (human PPD). For routine Mantoux test 2 units (0.1 ml of 20 units/ml strength) is administered to the left forearm, preferably at the junction of middle and at lower third of the volar aspect. It should produce a bleb raised about 7 mm in diameter, which usually disappears within an hour. If first test is negative and a further test is considered appropriate 10 units (0.1 ml of 100 units/ml strength) should be administered. Mantoux test should be read at 48–72 hours and measure the diameter of induration (not erythema) in millimetres (Fig. 38.21).

Interpretation of Mantoux test is given in Box 38.3.

#### Box 38.3: Interpretation of Mantoux test

- Less than 5 mm induration—it is negative
- If induration 5–10 mm—it could be due to previous BCG or due to non-tuberculous mycobacteria
- If induration 10–15 mm—treat as tuberculosis infection (known contact from high prevalence area). Treat as tuberculosis disease if chest X-ray abnormal and/or symptoms
- If induration more than 15 mm—treat as tuberculosis disease (abnormal chest X-ray and/or symptoms)



Fig. 38.21: A positive Mantoux test with human PPD

#### Key Learning Point

##### Mantoux test

- ➔ Importantly, the only indication for administering a more dilute human PPD (e.g. 0.1 ml of 1 in 10,000 PPD = 1 unit), is if the child is suspected to have erythema nodosum as a manifestation of primary tuberculosis.





Fig. 38.22: A positive Mantoux test with avian PPD

### Avian PPD (Non-Tuberculous Mycobacteria Intradermal Test)

Lymphadenitis is the most common manifestation of non-tuberculous mycobacteria (NTM) infection in children aged less than 12 years (peak age 2–4 years). Adenitis due to NTM is usually unilateral and involves the submandibular nodes or anterior superior cervical nodes. The pulmonary infection with NTM is rare in children.

With high index of suspicion that a child could have NTM infection, an avian PPD intradermal (Mantoux method test should be done). It will show a much higher sensitivity to the avian PPD than to the human PPD, and the reaction would be larger to the avian PPD than the human antigen (Fig. 38.22).

#### Key Learning Points

- Response to tuberculin may be suppressed by live viral vaccine, viral infection, corticosteroid therapy or immunosuppression due to disease or treatment.
- False negatives may be found in miliary tuberculosis or in newborns.
- Incorrect storage of PPD, incorrect administration or incorrect reading will affect the result.

Polymerase chain reaction may have a useful but limited role in evaluating children with tuberculosis. A negative PCR never eliminates tuberculosis as a diagnostic possibility, and a positive result does not confirm it.

### Allergy Skin Prick Testing

Skin prick testing is a form of allergy testing which produces an immunoglobulin E (IgE) mediated response on the surface of the skin. The reaction consists of a weal, which can be surrounded by erythema. This usually develops within 15 minutes and subsides within 1 hour. The resulting weal can help identify an offending allergen. It is essential to remember that false positives and false negatives can occur. Therefore, the child's history is of great significance.

The likelihood of systemic reactions is very low. However, the anaphylaxis medication and protocol must be readily available.

The child should be physically well prior to skin prick testing. No oral antihistamine should have been given on the day of the skin prick testing. Steroid ointment should not have been applied for the week prior to the skin prick testing. Also any areas of active eczema should be avoided.

#### Equipment Required

- Vials of commercially produced allergen extracts or whole food
- Positive and negative control skin prick testing solutions
- Individual sterile prick testing lancets
- A roll of transparent tape
- Skin marker pen
- Measuring gauge
- Timer
- Anaphylaxis medication.

#### Skin Prick Testing Procedure

The cubital fossa or the child's back is the site of choice for skin prick testing. Babies and toddlers tend to have the back used whereas older children tend to prefer it on the cubital fossa. A skin marking pen is used to mark allergen sites. Positive and negative controls are used on opposite sides of the test site. Allergens should be placed at least 3 cm apart.

One drop of allergen is placed on the appropriately marked area of the skin using the applicator.

A sterile lancet is held at a 90 degree angle to the skin and pressed through the skin without drawing blood. The excess solution is then removed with cotton wool or tissue from the skin site test. The above steps are repeated for each allergen. This is left for 15 minutes. After 15 minutes from application the site is examined for weals. Outlines of any weal are drawn round with the skin marker pen. Any flare that has occurred is disregarded. The tape is then placed over the pen marked weal to obtain an imprint and then removed and placed on the skin prick testing result sheet. This will have transferred the size of weal to the

result sheet. The diameter of the weal is measured with a ruler giving the diameter in millimetres. The skin is then washed around the site of the skin prick testing. The child is observed for a further 15 minutes. The results are interpreted and the appropriate advice and treatment plan devised.

However, scratch, prick or puncture tests should be employed with caution. Because, “large local skin test reactions” correlate well with clinical sensitivity while “small skin test reactions” correlate poorly but may be used as a starting point for elimination and challenge to determine whether clinical sensitivity to food exists. Also the clinical significance of skin test reactions varies significantly to specific food tested. Delayed-onset food sensitivities, i.e. reactions that occur hours to days after food ingestion, seldom are identified by skin testing because majority do not appear to be IgE mediated.

### Muscle Biopsy

Muscle biopsy is an invasive technique and both paediatrician and pathologist must be quite clear that there are questions that need to be answered for the diagnosis and management of the patient and indeed that those questions can be answered by a biopsy before the muscle biopsy procedure is carried out. Therefore, when indicated the muscle biopsy provides the final confirmation of a diagnosis on which treatment can be based, prognosis explained and genetic counselling offered. In some cases however the diagnosis may be quite clear from the clinical presentation and the history with no further, useful information is likely to be obtained from a

biopsy. In such a situation it should not be undertaken merely to confirm what is already known.

For practical purposes, most muscle biopsies are taken from quadriceps or deltoid as they are usually involved in myopathies. It is vital to avoid artefact in the muscle biopsy, e.g. sites of injection or EMG needle insertion. An open biopsy can be obtained through a skin incision under local anaesthesia. It is recommended to take two pieces of muscle: (1) one for electron microscopy and (2) the other for histology and histochemistry.

Needle biopsies of muscle can also be used for the diagnosis of muscle disease and are particularly useful for follow-up biopsies to monitor the prognosis of treatment.

### ACKNOWLEDGEMENTS

We are grateful to Churchill Livingstone Elsevier, for permission to reproduce some material from the Textbook of Paediatrics, Edited by John O Forfar and Gavin C Arneil, volume 2, chapter 38, Practical Procedures by WB Doig, Anna V Murphy and GC Arneil, 1978.

The authors also acknowledge their thanks to Mrs Pamela Joannidis, Miss M Steven, Dr B El-Nabulsi, Dr N Doraiswamy, Mr B Amjad for their contributions to this chapter.

The authors are grateful to ADAM Surgical, Sialkot, Pakistan, for providing images of suturing.

### BIBLIOGRAPHY

1. Safe sedation of children undergoing diagnostic and therapeutic procedures. A national clinical guideline. Guideline 58. Scottish Intercollegiate Guideline Network. May 2004.

# Appendices

## Notes on International System of Units (SI Units)

### Examples of Basic SI Units

Length	metre (m)
Mass	kilogram (kg)
Amount of substance	mole (mol)
Energy	joule (J)
Pressure	pascal (Pa)

## Units of Volume and Concentration

Volume. The base SI unit of volume is the cubic metre (1,000 litre). Because of its convenience the litre is used as the unit of volume in laboratory work.

Amount of Substance ('Molar') Concentration (e.g., mol/L,  $\mu\text{mol/L}$ ) is used for substances of defined chemical composition. It replaces equivalent concentration (mEq/L) which is not part of the SI system—for reporting measurements of sodium, potassium, chloride and bicarbonate (the numerical value of these four measurements is unchanged because the ions are univalent).

Mass Concentration (e.g., g/L,  $\mu\text{g/L}$ ) is used for all protein measurements, for substances which do not have a sufficiently well defined composition and for plasma vitamin B<sub>12</sub> and folate measurements. The numerical value in SI units will change by a factor of 10 in those instances previously expressed in terms of 100 ml.

Haemoglobin is an exception. It is agreed internationally that meantime haemoglobin should continue to be expressed in terms of g/dl (g/100 ml).

## APPENDIX A: GUIDE TO BIOCHEMICAL VALUES

Those where large differences occur when compared to adult reference ranges are highlighted.

## Blood

Acid-base [H <sup>+</sup> ]	38-45 nmol/L	pH 7.35-7.42 (Neonates especially premature pH 7.2-7.5)
pCO <sub>2</sub>	4.5-6.0 kPa	(32-45 mmHg)
pO <sub>2</sub>	11-14 kPa	(78-105 mmHg)
Bicarbonate [HCO <sub>3</sub> <sup>-</sup> ]	22-27 mmol/L	(Preterm/ < 1 month) (17-25 mmol/L)
Base excess	- 4 to +3 mmol/L	

## Plasma: Electrolytes and Minerals

Sodium		135-145 mmol/L
<i>Potassium chloride</i>	Newborns	4.3-7.0 mmol/L
	Older Children	3.5-5.0 mmol/L
		95-105 mmol/L
<i>Calcium phosphate</i> (lower in breastfed)	Preterm	1.5-2.5 mmol/L
	First year	2.25-2.75 mmol/L
	Children	2.25-2.70 mmol/L
	Preterm	1.4-3.0 mmol/L
	First year	1.2-2.5 mmol/L
	Children	0.9-1.8 mmol/L
Magnesium	Children	0.7-1.0 mmol/L
<i>Copper</i>	Birth to 4 weeks	5.0-12.0 $\mu\text{mol/L}$
	17-24 weeks	5.0-17.0 $\mu\text{mol/L}$
	25-52 weeks	8.0-21.0 $\mu\text{mol/L}$
	> 1 year	12.0-24.0 $\mu\text{mol/L}$
Zinc		9.0-18.0 $\mu\text{mol/L}$
<i>Iron</i>	< 3 years	5.0-30.0 $\mu\text{mol/L}$
	> 3 years	15.0-45.0 $\mu\text{mol/L}$
Ceruloplasmin	Newborn	0.05-0.26 g/L
	Children	0.25-0.45 g/L
<b>Ferritin</b>	Infant	20-200 ng/mL
	Children	10-100 ng/mL

## Plasma: Other Analytes

Acetoacetate (incl. acetone)	< 30	mg/L
AFP	< 6 months	
(Very high levels especially if premature—rapid fall over a week expected)		

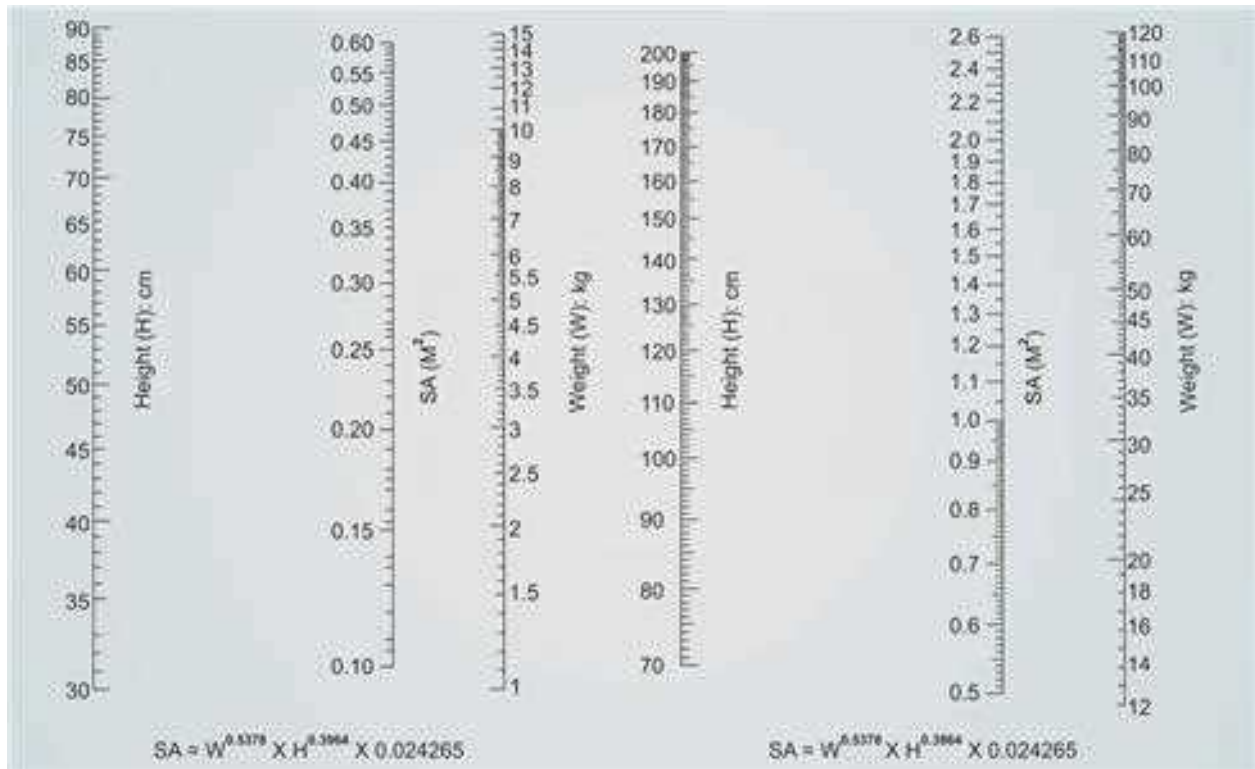


## APPENDIX B: A GUIDE TO NORMAL RANGES FOR THE FBC IN INFANCY AND CHILDHOOD

Age	Haemoglobin (g/dl)	Hct	MCV (fl)	WBC ( $\times 10^9/l$ )	Neutrophils ( $\times 10^9/l$ )	Lymphocytes ( $\times 10^9/l$ )	Monocytes ( $\times 10^9/l$ )	Eosinophils ( $\times 10^9/l$ )	Basophils ( $\times 10^9/l$ )	Platelets ( $\times 10^9/l$ )
Birth (term)	14.9–23.7	0.47–0.75	100–125	10–26	2.7–14.4	2.0–7.3	0–1.9	0–0.85	0–0.1	150–450
2 weeks	13.4–19.8	0.41–0.65	88–110	6–21	1.5–5.4	2.8–9.1	0.1–1.7	0–0.85	0–0.1	170–500
2 months	9.4–13.0	0.28–0.42	84–98	5–15	0.7–4.8	3.3–10.3	0.4–1.2	0.05–0.9	0.02–0.13	210–650
6 months	10.0–13.0	0.3–0.38	73–84	6–17	1–6	3.3–11.5	0.2–1.3	0.1–1.1	0.02–0.2	210–560
1 year	10.1–13.0	0.3–0.38	70–82	6–16	1–8	3.4–10.5	0.2–0.9	0.05–0.9	0.02–0.13	200–550
2–6 years	11.0–13.8	0.32–0.4	72–87	6–17	1.5–8.5	1.8–8.4	0.15–1.3	0.05–1.1	0.02–0.12	210–490
6–12 years	11.1–14.7	0.32–0.43	76–90	4.5–14.5	1.5–8.0	1.5–5.0	0.15–1.3	0.05–1.0	0.02–0.12	170–450
12–18 years Female	12.1–15.1	0.35–0.44	77–94	4.5–13	1.5–6	1.5–4.5	0.15–1.3	0.05–0.8	0.02–0.12	180–430
Male	12.1–16.6	0.35–0.49	77–92							

Reproduced with permission from: Simpson P, Hincliffe R/Arcei R, Hann I, Smith O. Table of normal ranges and blood counts from birth to 18 years; Paediatric Haematology, Blackwell Publishing, 2006.

## APPENDIX C: SURFACE AREA NOMOGRAMS IN INFANTS AND CHILDREN

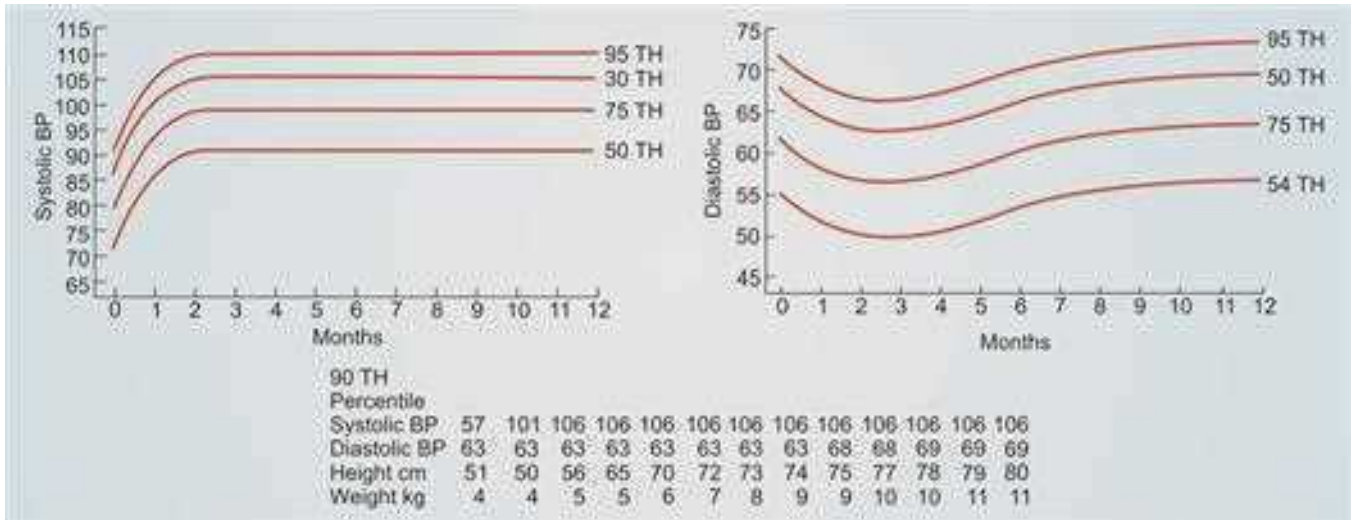


(a)

(b)

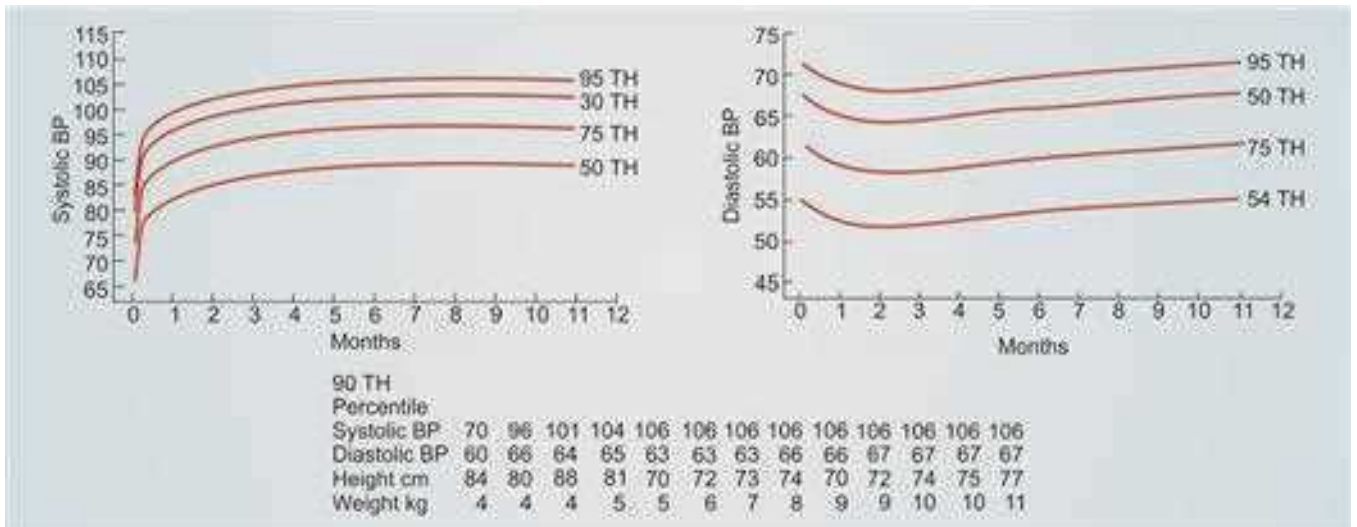
- (a) Nomogram representing the relationship between height, weight and body surface area in infants. (After Haycock, et al. Geometric method for measuring body surface area: A height-weight formula validated in infants, children and adults. *J Pediatrics* 1978;93:64–65).
- (b) Nomogram representing the relationship between height, weight and body surface area in children and adults. (After Haycock, et al. Geometric method for measuring body surface area: A height-weight formula validated in infants, children and adults, *J Pediatrics* 1978;93:64–65 (The editors and publisher gratefully acknowledge to reproduce the nomograms in this book).

**APPENDIX D: PERCENTILES OF AGE SPECIFIC BLOOD PRESSURE MEASUREMENTS IN BOYS AND GIRLS**



**Fig. D1:** Age-specific percentiles of BP measurements in boys—birth to 12 months of age. Korotkoff phase IV (K4) used for diastolic BP

(Source D1: Reproduced with permission from Pediatrics:79;1-25, Figure 1,2,3, & 4 ;1987 Copyright © AAP)



**Fig. D2:** Age-specific percentiles of BP measurements in girls—birth to 12 months of age; Korotkoff phase IV (K4) used for diastolic BP

(Source D2: Reproduced with permission from Pediatrics: 79; 1-25, Figure 1,2,3 & 4 ;1987. Copyright © AAP)





Table D1: BP levels for boys by age and height percentile

Age, yr	BP Percentile	SBP, mmHg							DBP, mmHg						
		Percentile of Height							Percentile of Height						
		5th	10th	25th	50th	75th	90th	95th	5th	10th	25th	50th	75th	90th	95th
1	50th	80	81	83	85	87	88	89	34	35	36	37	38	39	39
	90th	94	95	97	99	100	102	103	49	50	51	52	53	53	54
	95th	98	99	101	103	104	106	106	54	54	55	56	57	58	58
	99th	105	106	108	110	112	113	114	61	62	63	64	65	66	66
2	50th	84	85	87	88	90	92	92	39	40	41	42	43	44	44
	90th	97	99	100	102	104	105	106	54	55	56	57	58	58	59
	95th	101	102	104	106	108	109	110	59	59	60	61	62	63	63
	99th	109	110	111	113	115	117	117	66	67	68	69	70	71	71
3	50th	86	87	89	91	93	94	95	44	44	45	46	47	48	48
	90th	100	101	103	105	107	108	109	59	59	60	61	62	63	63
	95th	104	105	107	109	110	112	113	63	63	64	65	66	67	67
	99th	111	112	114	116	118	119	120	71	71	72	73	74	75	75
4	50th	88	89	91	93	95	96	97	47	48	49	50	51	51	52
	90th	102	103	105	107	109	110	111	62	63	64	65	66	66	67
	95th	106	107	109	111	112	114	115	66	67	68	69	70	71	71
	99th	113	114	116	118	120	121	122	74	75	76	77	78	78	79
5	50th	90	91	93	95	96	98	98	50	51	52	53	54	55	55
	90th	104	105	106	108	110	111	112	65	66	67	68	69	69	70
	95th	108	109	110	112	114	115	116	69	70	71	72	73	74	74
	99th	118	119	120	122	123	125	125	77	78	79	80	81	81	82
6	50th	91	92	94	96	98	99	100	53	53	54	55	56	57	57
	90th	105	106	108	110	111	113	113	68	68	69	70	71	72	72
	95th	109	110	112	114	115	117	117	72	72	73	74	75	76	76
	99th	116	117	119	121	123	124	125	80	80	81	82	83	84	84
7	50th	92	94	95	97	99	100	101	55	55	56	57	58	59	59
	90th	106	107	109	111	113	114	115	70	70	71	72	73	74	74
	95th	110	111	113	115	117	118	119	74	74	75	76	77	78	78
	99th	117	118	120	122	124	125	126	82	82	83	84	85	86	86
8	50th	94	95	97	99	100	102	102	56	57	58	59	60	60	61
	90th	107	109	110	112	114	115	116	71	72	73	74	75	75	76
	95th	111	112	114	116	118	119	120	75	76	77	78	79	79	80
	99th	119	120	122	123	125	127	127	83	84	85	86	87	87	88
9	50th	95	96	98	100	102	103	104	57	58	59	60	61	61	62
	90th	109	110	112	114	115	117	118	72	73	74	75	76	76	77
	95th	113	114	116	118	119	121	121	76	77	78	79	80	81	81
	99th	120	121	123	125	127	128	129	84	85	86	87	88	88	89
10	50th	97	98	100	102	103	105	106	58	59	60	61	61	62	63
	90th	111	112	114	115	117	119	119	73	73	74	75	76	77	78
	95th	115	116	117	119	121	122	123	77	78	79	80	81	81	82
	99th	122	123	125	127	128	130	130	85	86	86	88	88	89	90
11	50th	99	100	102	104	105	107	107	59	59	60	61	62	63	63
	90th	113	114	115	117	119	120	121	74	74	75	76	77	78	78
	95th	117	118	119	121	123	124	125	78	78	79	80	81	82	82
	99th	124	125	127	129	130	132	132	86	86	87	88	89	90	90
12	50th	101	102	104	106	108	109	110	59	60	61	62	63	63	64
	90th	115	116	118	120	121	123	123	74	75	76	77	78	78	79
	95th	119	120	122	123	125	127	127	78	79	80	81	82	82	83
	99th	126	127	129	131	133	134	135	86	87	88	89	90	90	91
13	50th	104	105	106	108	110	111	112	60	61	62	63	64	64	64
	90th	117	118	120	122	124	125	126	75	75	76	77	78	79	79
	95th	121	122	124	126	128	129	130	79	79	80	81	82	83	83
	99th	128	130	131	133	135	136	137	87	87	88	89	90	91	91
14	50th	106	107	109	111	113	114	115	60	61	62	63	64	65	65
	90th	120	121	123	125	126	128	128	75	76	77	78	79	79	80
	95th	124	125	127	128	130	132	132	80	80	81	82	83	84	84
	99th	131	132	134	136	138	139	140	87	88	89	90	91	92	92
15	50th	109	110	112	113	115	117	117	61	62	63	64	65	66	66
	90th	122	124	125	127	129	130	131	76	77	78	79	80	80	81
	95th	126	127	129	131	133	134	135	81	81	82	83	84	85	85
	99th	134	135	136	138	140	142	142	88	89	90	91	92	93	93
16	50th	111	112	114	116	118	119	120	63	63	64	65	66	67	67
	90th	125	126	128	130	131	133	134	78	78	79	80	81	82	82
	95th	129	130	132	134	135	137	137	82	83	83	84	85	86	87
	99th	136	137	139	141	143	144	145	90	90	91	92	93	94	94
17	50th	114	115	116	118	120	121	122	65	66	66	67	68	69	70
	90th	127	128	130	132	134	135	136	80	80	81	82	83	84	84
	95th	131	132	134	136	138	139	140	84	85	86	87	87	88	89
	99th	139	140	141	143	145	146	147	92	93	93	94	95	96	97

The 90th percentile is 1.28 SD, the 95th percentile is 1.645 SD, and the 99th percentile is 2.326 SD over the mean. For research purposes, the SDs in Table B1 allow one to compute BP Zscores and percentiles for boys with height percentiles given in Table 3 (i.e. the 5th, 10th, 25th, 50th, 75th, 90th, and 95th percentiles). These height percentiles must be converted to height Z scores given by: 5% = -1.645; 10% = -1.28; 25% = -0.68; 50% = 0; 75% = 0.68; 90% = 1.28; and 95% = 1.645, and then computed according to the methodology in steps 2 through 4 described in Appendix B. For children with height percentiles other than these, follow steps 1 through 4 as described in Appendix B.

(Source D1: BP levels for boys by age and height percentiles Reproduced with permission from Pediatrics 114: 556-576, Table 3 & 4 2004. Copyright © AAP)

Table D2: BP levels for girls by age and height percentile

Age, yr	BP Percentile	SBP, mmHg								DBP, mmHg							
		Percentile of Height								Percentile of Height							
		5th	10th	25th	50th	75th	90th	95th	5th	10th	25th	50th	75th	90th	95th		
1	50th	83	84	85	86	88	89	90	38	39	39	40	41	41	42		
	90th	97	97	98	100	101	102	103	52	53	53	54	55	55	56		
	95th	100	101	102	104	105	106	107	56	57	57	58	59	59	60		
	99th	108	108	109	111	112	113	114	64	64	65	65	66	67	67		
2	50th	85	85	87	88	89	91	91	43	44	44	45	46	46	47		
	90th	98	99	100	101	103	104	105	57	58	58	59	60	61	61		
	95th	102	103	104	105	107	108	109	61	62	62	63	64	65	65		
	99th	109	110	111	112	114	115	116	69	69	70	70	71	72	72		
3	50th	86	87	88	89	91	92	93	47	48	48	49	50	50	51		
	90th	100	100	102	103	104	106	106	61	62	62	63	64	64	65		
	95th	104	104	105	107	108	109	110	65	66	66	67	68	68	69		
	99th	111	111	113	114	115	116	117	73	73	74	74	75	76	76		
4	50th	88	89	90	91	92	94	94	50	50	51	52	52	53	54		
	90th	101	102	103	104	106	107	108	64	64	65	66	67	67	68		
	95th	105	106	107	108	110	111	112	68	68	69	70	71	71	72		
	99th	112	113	114	115	117	118	119	76	76	76	77	78	79	79		
5	50th	89	90	91	93	94	95	96	52	53	53	54	55	55	56		
	90th	103	103	105	106	107	109	109	66	67	67	68	69	69	70		
	95th	107	107	108	110	111	112	113	70	71	71	72	73	73	74		
	99th	114	114	116	117	118	120	120	78	78	79	79	80	81	81		
6	50th	91	92	93	94	96	97	98	54	54	55	56	56	57	58		
	90th	104	105	106	108	109	110	111	68	68	69	70	70	71	72		
	95th	108	109	110	111	113	114	115	72	72	73	74	74	75	76		
	99th	115	116	117	119	120	121	122	80	80	80	81	82	83	83		
7	50th	93	93	95	96	97	99	99	55	56	56	57	58	58	59		
	90th	106	107	108	109	111	112	113	69	70	70	71	72	72	73		
	95th	110	111	112	113	115	116	116	73	74	74	75	76	76	77		
	99th	117	118	119	120	122	123	124	81	81	82	82	83	84	84		
8	50th	95	95	96	98	99	100	101	57	57	57	58	59	60	60		
	90th	108	109	110	111	113	114	114	71	71	71	72	73	74	74		
	95th	112	112	114	115	116	118	118	75	75	75	76	77	78	78		
	99th	119	120	121	122	123	125	125	82	82	83	83	84	85	86		
9	50th	96	97	98	100	101	102	103	58	58	58	59	60	61	61		
	90th	110	110	112	113	114	116	116	72	72	72	73	74	75	75		
	95th	114	114	115	117	118	119	120	76	76	76	77	78	79	79		
	99th	121	121	123	124	125	127	127	83	83	84	84	85	86	87		
10	50th	98	99	100	102	103	104	105	59	59	59	60	61	62	62		
	90th	112	112	114	115	116	118	118	73	73	73	74	75	76	76		
	95th	116	116	117	119	120	121	122	77	77	77	78	79	80	80		
	99th	123	123	125	126	127	129	129	84	84	85	86	86	87	88		
11	50th	100	101	102	103	105	106	107	60	60	60	61	62	63	63		
	90th	114	114	116	117	118	119	120	74	74	74	75	76	77	77		
	95th	118	118	119	121	122	123	124	78	78	78	79	80	81	81		
	99th	125	125	126	128	129	130	131	85	85	86	87	87	88	89		
12	50th	102	103	104	105	107	108	109	61	61	61	62	63	64	64		
	90th	116	116	117	119	120	121	122	75	75	75	76	77	78	78		
	95th	119	120	121	123	124	125	126	79	79	79	80	81	82	82		
	99th	127	127	128	130	131	132	133	86	86	87	88	88	89	90		
13	50th	104	105	106	107	109	110	110	62	62	62	63	64	65	65		
	90th	117	118	119	121	122	123	124	76	76	76	77	78	79	79		
	95th	121	122	123	124	126	127	128	80	80	80	81	82	83	83		
	99th	128	129	130	132	133	134	135	87	87	88	89	89	90	91		
14	50th	106	106	107	109	110	111	112	63	63	63	64	65	66	66		
	90th	119	120	121	122	124	125	125	77	77	77	78	79	80	80		
	95th	123	123	125	126	127	129	129	81	81	81	82	83	84	84		
	99th	130	131	132	133	135	136	136	88	88	89	90	90	91	92		
15	50th	107	108	109	110	111	113	113	64	64	64	65	66	67	67		
	90th	120	121	122	123	125	126	127	78	78	78	79	80	81	81		
	95th	124	125	126	127	129	130	131	82	82	82	83	84	85	85		
	99th	131	132	133	134	136	137	138	89	89	90	91	91	92	93		
16	50th	108	108	110	111	112	114	114	64	64	65	66	66	67	68		
	90th	121	122	123	124	126	127	128	78	78	79	80	81	81	82		
	95th	125	126	127	128	130	131	132	82	82	83	84	85	85	86		
	99th	132	133	134	135	137	138	139	90	90	90	91	92	93	93		
17	50th	108	109	110	111	113	114	115	64	65	65	66	67	67	68		
	90th	122	122	123	125	126	127	128	78	79	79	80	81	81	82		
	95th	125	126	127	129	130	131	132	82	83	83	84	85	85	86		

\* The 90th percentile is 1.28 SD, the 95th percentile is 1.645 SD, and the 99th percentile is 2.326 SD over the mean. For research purposes, the SDs in Table B1 allow one to compute BP Z scores and percentiles for girls with height percentiles given in Table 4 (i.e. the 5th, 10th, 25th, 50th, 75th, 90th and 95th percentiles). These height percentiles must be converted to height Z scores given by: 5% = -1.645; 10% = -1.28; 25% = -0.68; 50% = 0; 75% = 0.68; 90% = 1.28; and 95% = 1.645 and then computed according to the methodology in steps 2 through 4 described in Appendix B. For children with height percentiles other than these, follow steps 1 through 4 as described in Appendix B.

(Source D2: BP levels for girls by age and height percentile Reproduced with permission from Pediatrics: 114: 556-576, Table 3 & 4; 2004. Copyright © AAP)

## APPENDIX E: CHILDHOOD MYOSITIS ASSESSMENT SCALE (CMAS) SCORING SHEET

### Head Lift

0=Unable      3=30–59 sec  
 1=1–9 sec      4=60–119 sec  
 2=10–29 sec      5= ≤ 2 min      # of sec---

### Leg Raise/Touch Object

0=Unable to lift leg off table  
 1=Able to clear table, but cannot touch object (examiner's hand).  
 2=Able to lift leg high enough to touch object (examiner's hand).

### Straight Leg Lift/Duration

0=Unable      3=30-59 sec  
 1=1-9 sec      4=60-119 sec  
 2=10-29 sec      5= ≤ 2 min      # of sec ---

### Supine to Prone

0=Unable. Has difficulty even turning onto side, able to pull right arm under torso only slightly or not at all  
 1=Turns onto side fairly easily, but cannot fully free right arm, and is unable to fully assume a prone position  
 2=Easily turns onto side, has some difficulty freeing arm, but fully frees arm and fully assumes a prone position  
 3=Easily turns over, fully frees right arm with no difficulty

### Sit-ups

Hands on thighs, with counterbalance      -----  
 Hands across chest, with counterbalance      -----  
 Hands behind head, with counterbalance      -----  
 Hands on thighs, without counterbalance      -----  
 Hands across chest, without counterbalance      -----  
 Hands behind head, without counterbalance      -----  
 Total Sit-up Score (0-6)

### Supine to Sit

0=Unable by self  
 1=Much difficulty, Very slow, struggles greatly, barely makes it almost unable  
 2=Some difficulty. Able, but is somewhat slow struggles some  
 3=No difficulty.

### Arm Raise/Straighten

0=Cannot raise wrists up to the level of the A-C joint  
 1=Can raise wrists at least up to the level of the A-C joint, but not above top of head.

2=Can raise wrists above top of head, but cannot raise arms straight above head so that elbows are in full extension  
 3=Can raise arms straight above head so that elbows are in full extension.

**Arm Raise/Duration:** Can maintain wrists above top of head for:

0=Unable  
 1=1-9 sec  
 2=10-29 sec  
 3=30-59 sec  
 4= ≤ 60 sec.      # of sec -----

### Floor Sit

Going from a standing position to a sitting position on the floor

0=Unable. Afraid to even try, even if allowed to use a chair for support. Child fears that he/she will collapse, fall into a sit, or harm self.  
 1=Much difficulty. Able, but needs to hold onto a chair for support during descent. Unable, or unwilling to try if not allowed to use a chair for support.  
 2= Some difficulty. Can go from stand to sit without using a chair for support, but has at least some difficulty during descent. May need Gower's.  
 Descends somewhat slowly and/or apprehensively, may not have full control Or balance as maneuvers into a sit.  
 3=No difficulty. Requires no compensatory maneuvering.

### All Fours Manoeuvre

0=Unable to go from a prone to an all-fours position  
 1=Barely able to assume and maintain an all fours position. Unable to raise head to look straight ahead.  
 2=Can maintain all-fours position with back straight and head raised (so as to look straight ahead). But, cannot creep (crawl) forward.  
 3=Can maintain all-fours, look straight ahead and creep (crawl) forward  
 4=Maintain balance while lifting and extending one leg.

### Floor Rise

Going from a kneeling position on the floor to a standing position

0=Unable, even if allowed to use a chair for support  
 1=Much difficulty. Able, but needs to use a chair for support (Unable if not allowed to use a chair).

- 2=Moderate difficulty. Able to get up without using a chair for support, but needs to place one  
Or both hands on thighs/knees or floor. (Unable without using hands)
- 3=Mild difficulty. Does not need to place hands on knees, thighs or floor, but has at least some difficulty during ascent.
- 4=No difficulty.

### Chair Rise

- 0= Unable to rise up from chair, even if allowed to place hands on sides of chair seat.
- 1= Much difficulty. Able, but needs to place hands on sides of seat.  
Unable if not allowed to place hands on sides of seat.
- 2= Moderate difficulty. Able, but needs to place hands on knees/thighs.  
Does not need to place hands on sides of seat.
- 3= Mild difficulty. Does not need to place hands on seat, knees or thighs, but has at least some difficulty during ascent.
- 4= No difficulty.

### Stool Step

- 0= Unable.
- 1= Much difficulty. Able, but needs to place one hand on exam table (or examiner's hand).
- 2= Some difficulty. Able, does not need to use exam table for support, but needs to use.  
Hand on knee/thigh

- 3= Able. Does not need to use exam table or hand on knee/thigh.

### Pick-up

- 0=Unable to bend over and pick up pencil off floor.
- 1=Much difficulty. Able, but relies heavily on support gained by placing hands on knees/thighs.
- 2=Some difficulty. Has some difficulty (but not "much - difficulty")  
Needs to at least minimally and briefly place hand(s) on knees/thighs for support Is somewhat slow.
- 3=No difficulty. No compensatory maneuver necessary.  
The maximum possible total score for the 14 maneuvers is 52 (52 "points of muscle strength/function")

Patient \_\_\_\_\_

Date \_\_\_\_\_

Total CMAS Score \_\_\_\_\_

Validation and Clinical Significance of the Childhood Myositis Assessment Scale for Assessment of Muscle Function in the Juvenile Idiopathic Inflammatory Myopathies, Appendix A: Childhood Myositis Assessment Scale (CMAS) Scoring Sheet. Huber et al, Arthritis and Rheumatism Vol 50, No 5 May 2004, page 1603. "This material is reproduced with permission of John Wiley & Sons, Inc"

# INDEX

Page numbers with *f* and *t* indicate figure and table, respectively

## A

- Abdomen 10, 675  
Abdomino PSARP 219  
Abdominoperineal pull-through 220  
Abnormal  
    behaviour and gestures 395  
    brain development 788*f*  
    coagulation tests 609*t*  
    lung vascularity 673*f*  
Abnormalities 41, 105, 462, 463*t*  
    growth 44  
Abscess 367, 694, 659*f*  
Absence seizure 371  
Absorption 224, 780  
Abuse 197, 786  
    and neglect 792  
Accidental poisoning  
    in childhood 399  
Acellular pertussis 530  
Acetabular  
    dysplasia 471*f*  
    labrum 707*f*  
    roof 705*f*, 706*f*  
Achondroplasia 703, 703*f*, 704*f*  
Acid-base status 191, 359  
Acidosis 191  
Acquired  
    abnormalities 105  
    heart disease 176  
    hypoplastic anaemia 312  
    lower respiratory tract problems 105  
    or traumatic brain injury 774  
Acrodermatitis enteropathica 297, 297*f*  
Actinomycosis 498  
Actions of  
    insulin preparations 459*t*  
Active cooling 32  
Active hepatitis 147  
Acute  
    alcohol poisoning 407  
    anaphylaxis 522  
    appendicitis 678  
    carbon monoxide poisoning 410  
    constipation 141  
    dacryocystitis 580*f*  
    encephalitis 364  
    encephalopathy 364, 365  
    epiglottitis 105  
    flaccid paralysis 368, 368*f*  
    immediate hypersensitivity and anaphylaxis 520  
    infarct 693*f*  
    infections 738  
    iron poisoning 404  
    leukaemias 318  
    middle ear infection 740*f*  
    myeloid leukaemia 319*f*, 320  
    orofacial infection 496  
    osteomyelitis 479  
    otitis media 105  
    phase proteins 509  
    poliomyelitis 368  
    postinfectious polyneuropathy 369  
    post-streptococcal glomerulonephritis 340  
    renal failure 356, 357, 357*t*  
    septic arthritis 478  
    severe asthma with marked hyperinflation 109*f*  
Acyanotic  
    child with congenital heart disease 671  
    congenital heart disease 162  
Adaptive immune system 510, 511  
Adductors 765*f*  
Adenoma sebaceum 380*f*  
Adenomatoid malformation 663  
Adjuvants 528  
Adolescent idiopathic scoliosis 474  
Adrenal  
    gland 450  
    hyperplasia 453, 454*f*  
    insufficiency 452, 453*t*  
Adrenoleukodystrophy 382  
Adult  
    and children in emergency department 618  
    bite marks 796*f*  
    hand slap 795*f*  
    skulls 745*f*  
Advanced  
    bronchiectasis in cystic fibrosis 115*f*  
    formulation 785  
    management of cardiopulmonary arrest 622  
Adverse  
    events 528  
    of vaccines 529*t*  
Advice for parents 757  
Aetiology of  
    caries 486  
    diarrhoea 149  
Affecting immune response 528  
Age and gender group 86*t*  
Agenesis of left kidney 720*f*  
Aggressive lesion 749*f*  
Aims of treatment 229  
Air  
    collection 662*f*  
    enema reduction 680*f*  
    fluid levels in small bowel 678*f*  
    trapping 659*f*  
Airway 400, 626, 637  
    and breathing 200, 618  
    obstruction 737*f*  
Albers-Schönberg disease 312  
Alcohol abuse 47  
Alcohol poisoning 407  
Alimentary system 849  
Alkaptonuria 419  
Allergen avoidance 524  
Allergic  
    conjunctivitis 578  
    disease 520  
    rhinitis 521  
Allergy 517, 522  
    skin prick testing 853  
Ambiguous genitalia 11*f*  
Amblyopia 569  
Ambulation 776*f*  
Ameloblastoma 750*f*  
Amelogenesis imperfecta 500, 501*f*  
Aminoglycoside  
    dosing 616  
    monitoring 616  
Amino acid metabolism 416, 419  
Amoebiasis 566  
Amorphous calcification 712*f*  
Anaemia 359  
    in acute renal failure 358  
    in malnourished children 83  
Anal pit 217*f*  
Analgesia 823  
Analgesic and sedative therapy 32  
Analysis of urine using chemical strips 837*f*  
Anaphylactoid reactions 520  
Anaphylaxis 522, 633*f*, 633  
Anatomic aetiological classification of  
    hydrocephalus 224  
Anatomy 484, 579  
    and aetiology 209  
    and classification 206  
    and physiology 618  
Anderson-Hynes pyeloplasty 246*f*  
Angiofibromas 284*f*  
Anomalies 46, 205, 207, 466, 498, 717  
Anomalies 498  
    in cementum 502  
    in enamel and dentine 500  
    in number of teeth 498  
    in size of teeth 499  
    in tooth shape 499  
Anomaly 218*f*  
Anorectal  
    anomaly 218*f*  
    malformation 214, 216*f*, 217*f*  
    reconstruction 219  
Antalgic gait 464  
Antenatal 207  
    history 187  
Anterior  
    cataract 585  
    maxilla 749*f*

- mediastinum 662*f*, 667*f*  
 open bite 744*f*  
 segment dysgenesis 583  
 uveitis 590  
 Anterolateral bowing of tibia 469  
 Anteversion 464*f*  
 Antibacterial agents 509  
 Antibiotic  
   monitoring 616  
   and interpretation 616  
   therapy  
     for infectious diarrhoea 155*t*  
     in children with bacterial meningitis 362*t*  
   treatment of neonatal meningitis and sepsis 55*t*  
 Antibiotics 114  
 Anticonvulsants 373  
 Antidotes 402  
 Antigens 512*f*, 615  
   presentation and T cells 511  
 Antihistamines 524  
 Anti-IgE 526  
 Antimalarials 406  
 Anti-TB drugs 548*t*  
 Antivenom treatment 410  
 Antral erosion secondary to NSAIDs 328*f*  
 Aorta 177*f*, 666*f*  
 Aortic  
   arch 675*f*  
   coarctation 166*f*, 167*f*  
   hiatus 668*f*  
   stenosis 167, 184  
 Aortopulmonary 673*f*  
 Apert deformity 732*f*  
 Apex 670*f*  
 Aphthous 491*f*  
   ulceration 491  
 Apnoea 39  
 Appearance 62  
 Appendicitis 678  
 Appendix 679*f*  
 Approach to injured child 193  
 Appropriate antimicrobial therapy 155  
 Arch 675, 675*f*  
   anomalies 230  
 Areas of atelectasis 663*f*  
 Argininaemia 421  
 Arms 15  
 Array CGH 71*f*  
 Arrest 620  
 Arterialised capillary blood 840  
 Arthralgia 323, 324*t*  
 Arthritis 323, 324*t*  
 Arthropathy 330  
 Ascorbic acid deficiency 92  
 Aseptic meningitis 363  
 Asphyxia 51  
 Aspiration pneumonia 108  
 Aspirin 493*f*  
 Assay detection limits 613  
 Assessing vision 570  
 Assessment of  
   airway 400  
   breathing 400  
   child and management 399  
   circulation 400  
   conscious level 400  
   emotional abuse 793  
   extent of child neglect 787  
   eye movements 571  
   neurological function 401  
   short stature 437  
 Associated  
   anomalies 205, 207  
     in myelomeningocele 222  
   disabilities 390  
   infections 562  
   manifestations 323  
   medical problems 188  
 Asthma 108, 110*f*, 632  
   management plan 110*f*  
 Astrocytoma 698  
 Asymmetrical  
   IUGR 55*t*  
   lung hyperinflation 663*f*  
 Asymmetry 65  
 Ataxia telangiectasia 381, 517  
 ATLS approach to trauma 194*t*  
 Atonic seizures 372  
 Atopic  
   disease 519  
   eczema 288  
   keratoconjunctivitis 579  
 Atresia 676  
 Atrial septal defect 164, 165*f*, 184, 671  
 Atrioventricular septal defect 164, 165*f*, 184  
 Atrium 670*f*  
 Atropine poisoning 405  
 Attention deficit hyperkinetic disorder 647  
 Auscultation 102, 159  
 Automated blood pressure measurement 828  
 Autoimmune  
   haemolytic anaemia 309  
   thyroiditis 443  
 Autonomic nervous system 385  
 Autosomal  
   recessive  
     inheritance 60  
     polycystic kidney disease 721, 721*f*  
     trisomies 65*t*  
 Avian PPD 853  
 Avulsion injury 503*f*, 505*f*  
 Axillary freckling 285*f*
- B**
- B cell function 515  
 B cells 512  
 B thalassaemia trait 600  
 Baby hypothermia 31  
 Bacterial  
   antigens 615  
   infections 496, 657*f*  
   pneumonia 106, 657  
 Bacteriuria 614  
 Balance 359  
 Bands 685*f*  
 Barbiturate poisoning 405  
 Barlow and Ortolani tests 470*f*  
 Basic  
   life support 620  
   structure of  
     immunoglobulin and classes 511*f*  
   structured approach to management 619  
   techniques 833  
     interrupted and mattress sutures 833  
 Basilar artery 377*f*  
 Basophilic stippling 600  
 Basophils 510  
 Beaten skull deformity 732*f*  
 Becker muscular dystrophy 384  
 Beckwith-Wiedemann syndrome 42, 43*f*  
 Behaviour disorders 647  
 Behavioural indicators 798  
 Behcet's disease 339  
 Benefits of organised play 759  
 Benign  
   aggressive lesion 749*f*  
   joint hypermobility syndrome 330  
   tumours 481  
 Beta thalassaemia minor 307  
 Biconvex collection of blood 689*f*  
 Bilateral  
   frontal infarcts 377*f*  
   grade 2 vesicoureteric reflux 723*f*  
   inguinal hernia 242*f*  
   lung contusions 681*f*  
   undescended testes 249*f*  
   upper limb trans-radial amputee 779*f*  
   vesicoureteric reflux 345*f*  
   Wilms' tumour 724*f*  
 Biliary atresia 237  
 Bilious vomiting 675, 676*f*  
 Bilirubin metabolism 235  
 Bilobed appearance 666*f*  
 Biochemical tests 613  
 Biological agents 328  
 Biotin and pantothenic acid 97  
 Birth  
   asphyxia 51  
   history 100, 187  
   weight babies 56*t*  
 Bite  
   cells 599  
   marks 796*f*  
 Bites 793  
 Bitot's spots 581*f*  
 Bitten by dog 193*f*  
 Blackfan diamond anaemia 310, 311*f*  
 Bladder  
   and prostate 267  
   calculus 722*f*  
   stones 248  
 Blaschko lines 284*f*  
 Bleeding 246  
   disorders 609*t*  
 Blindness 594, 595  
 Blistering disorders 286  
 Blood  
   bone marrow findings 318  
   cell 597*f*  
   clotting defects 315  
   coagulation cascade 315

- culture 827  
 film 306*f*, 596  
 glucose 837  
 per rectum 124  
 picture findings 318  
 samples 616, 825  
 screening tests  
   of homeostasis 315  
 tests 240  
 transfusion 191  
 volume  
   according to body weight 191*t*  
 Blount's disease 474*f*  
 Blow-out fracture 748*f*  
 Blunt  
   force trauma 794*f*  
   trauma 681*f*  
 Body  
   composition 781  
   fracture mandible 743*f*  
   plethysmograph 101*f*  
 Bodily systems 12  
 Boggy swelling 797*f*  
 Bohler orthosis 776*f*  
 Bohn's nodules 487  
 Bone  
   infections 712  
   marrow 319*f*  
     examination 606  
   plates 746*f*  
   tumours 716  
   window settings 715*f*  
   marrow findings 318  
 Bony  
   spur 701*f*  
   surgery 467  
 Boot shaped heart 170*f*, 672*f*  
 Botulinum 538  
 Bowing  
   deformity 706*f*  
   of lumbar lordosis 90*f*  
   of tibiae  
 Bow leg 90*f*  
 Bowel 222  
 Bowel obstruction to meconium ileus 113*f*  
 Bow-legs 474*f*  
 Boy with neurofibromatosis 72*f*  
 Braces 766*f*  
 Bracing 476  
 Brain  
   abscess 367, 694  
   stem glioma 699, 699*f*  
   tumour 386  
   water content 227  
   weights 55*t*  
 Brainstem function 222  
 Branched-chain amino acid metabolism 420  
 Branchial  
   arch anomalies 230  
   cleft sinuses and fistulae 231*f*  
   cyst 232  
 Breast development 23  
 Breath-holding attacks 373  
 Breathing 400, 626, 637  
 Bronchial wall cuffing 658*f*  
 Bronchiectasis 112, 114*f*, 632, 658, 658*f*  
   in cystic fibrosis 115*f*  
 Bronchiolitis 657  
   obliterans 116  
 Bronchogenic cyst 664  
 Bronchograms 660*f*  
 Bronchopleural fistula 660  
 Bronchopulmonary dysplasia 662  
 Bronchoscopy 846  
 Bruises 795*f*  
 Bruising 741*f*  
 Bubble appearance 676*f*  
 Build cubes 24*f*  
 Bullae formation 492*f*  
 Burkitt lymphoma 685  
 Burn wound healing 199  
 Burns 197, 198  
 Butterfly rash 334*f*  
**C**  
*C. diphtheriae* 534  
*C. tetani* 538  
 Café au lait macules 284, 285*f*  
 Calcaneo-navicular coalition 473*f*  
 Calcaneovalgus 468  
   deformity 468*f*  
 Calcinotic nodules 332*f*  
 Calculus  
   in bladder 350*f*  
   within lower pole of left kidney 722*f*  
 Campylobacter 616*t*  
 Candidal 498*f*  
 Candidiasis 488, 498  
 Capillary  
   haemangioma 489*f*  
   malformation 282, 282*f*  
   sampling 826  
 Carbol fuchsin stain 841  
 Carbon monoxide poisoning 410  
 Cardiac  
   and related conditions 673  
   arrest 620  
   catheter 161  
   disorders 45  
   lesion 634  
   tamponade 196  
   ventricular disproportion 206  
 Cardiff card 570*f*  
 Cardiology 157  
 Cardiomegalia glycogenica 426  
 Cardiomegaly 663*f*, 671*f*  
 Cardiomyopathy 180  
 Cardiovascular  
   support 32  
   system 2, 14, 848  
 Care of  
   newborn birth 52  
   paediatric surgical patient 186  
 Caries 486, 487*f*  
   prevention 486  
 Carriers 534  
 Cartilaginous femoral head 708*f*  
 Casal's necklace on neck 95*f*  
 Cascade 315*f*, 509*f*, 608*f*  
 Cataract 9*f*, 585, 585*f*, 586  
 Catheter 161  
 Cat-scratch disease 498  
 Caudothalamic groove 690*f*  
 Causes of  
   abnormal coagulation tests 609*t*  
   acute renal failure 357*t*  
   adrenal insufficiency 453*t*  
   anaemia  
     classified on red cell indices 602*t*  
   arthralgia 323  
   arthritis 323  
   child malnutrition 75*f*  
   childhood  
     blindness 595  
     stroke 376*t*  
   chronic renal failure 358*t*  
   corneal opacity 581  
   gastrointestinal bleeding 122*t*  
   heart failure by age 158*t*  
   hyperglycaemia 838, 838*t*  
   hypertension 348*t*  
   hypoglycaemia 460*t*, 838, 838*t*  
   hypogonadism 448*t*  
   hypopituitarism 434*t*  
   iron deficiency 85  
   musculoskeletal pain 465*t*  
   pem 75  
   precocious puberty 449*t*  
   short stature 437*t*  
   SIADH 436*t*  
   tall stature 438*t*  
   uveitis 588  
   vasopressin deficiency 435*t*  
 Caustic ingestion 408, 409*f*  
 Cautious feeding 81  
 Cavernous haemangioma 489*f*  
 Cavitation 487*f*, 692*f*  
 CD40 ligand deficiency 516  
 Cell 597*f*  
 Cells of  
   adaptive immune system 511  
   innate immune system 510  
 Cellulitis 578*f*  
 Central  
   nervous system 3, 842  
   peribronchial thickening 114*f*  
   venous access 838, 839  
   precocious puberty 451*t*  
 Cephalocele 685  
 Cerebellar  
   astrocytoma 698  
   function 15  
   vermis 696*f*  
 Cerebellum 697*f*, 698*f*  
 Cerebral  
   hemisphere 389*f*  
   palsy 386, 386*t*, 387*f*, 477, 765*f*  
 Cerebrospinal fluid 615  
   absorption 224  
   production 223, 227  
   with pus cells  
     and *E. coli* 842*f*  
     and *H. influenzae* 842*f*

- Cervical meningocele 221f  
 Cestodes 133  
 Charcot-Marie-Tooth peroneal muscular atrophy 382  
 Chemical injuries 583  
 Chemical mediators 519  
 Cherry-red spot 428f  
 Chest 10  
   injuries 118, 636  
   wall masses 668  
 Chiari I malformation 687, 687f  
 Chiari II malformation 701f  
 Chickenpox 557f  
 Child  
   abuse 197, 786  
   and adolescent psychiatry 639  
   and management 399  
   asthma management plan 110f  
   development 23  
   malnutrition 75f  
   mortality rates 50  
   neglect 786, 790f  
   nonaccidental injury 506  
   over three months of age 345  
   physical abuse 506  
   pornography 799  
   protection process for all staff 804  
   protection standardised procedures 801  
   sexual abuse 798  
     health consequences in adulthood 799  
   sex tourism 799  
   trafficking 799  
   under three months of age 345  
   with congenital heart disease 671  
   with cough and fever 657  
   with rickets 90f  
   with visual impairment 595  
 Childhood 24, 754  
   blindness 594  
   diarrhoea 149  
   lens disorders 585  
   obesity 439t  
   stroke 375  
 Chlamydia conjunctivitis 577  
 Choanal atresia 102  
 Choice of drains 246  
 Choking child 622, 622f  
 Cholangiopancreatography 240f  
 Cholecystitis 148  
 Choledochal cyst 238, 240f  
 Cholera 540  
 Chorionic inflammatory cells 137f  
 Choroid plexus 690f  
 Christmas disease 316  
 Chromium deficiency 98  
 Chromosomal  
   abnormalities 41  
   deletion syndromes 67  
   duplications 67  
   evaluation 257  
 Chromosome microdeletion syndromes 68f  
 Chronic  
   active hepatitis 147  
   constipation 141  
   foot ulcer 775f  
   granulomatous disease 516  
   iritidocyclitis 325f  
   renal failure 358, 358t  
 Circulation 35f, 400  
 Cirrhosis of liver 147  
 Classical pyloromyotomy 210  
 Classified on red cell indices 602t  
 Classification of  
   burns 198  
   cerebral palsy 386t  
   congenital heart disease 158t  
   diabetes mellitus 457t  
   disorder of sex development 456t  
   glomerulonephritis 340t  
   hypothyroidism 440t  
   IVH 58  
   PEM 75, 76t  
 Cleft 229  
   lip 228, 228f, 490  
   palate 228, 228f, 490, 490f  
     repair 735f  
   sinuses and fistulae 231f  
   surgery 230  
 Clefting defects 732  
 Clefts 228f  
 Clinical appearance of  
   foot of a child with metatarsus adductus 468f  
 Clinical difference  
   between two results 613t  
 Clinical disease  
   caused by *H. Influenzae* type B 544t  
 Clinical features associated  
   with dehydration 151t  
 Clinical features of  
   Crohn disease 134t  
   rickets 447t  
   ulcerative colitis 134t  
 Clostridial infections 538  
 Clostridium  
   botulinum 538  
   difficile 538  
 Clotting abnormalities 42  
 Clotting defects 315  
 Clubfoot 466, 466f, 466t, 467f  
   in MCC 467  
   in spina bifida 467  
 CMV infection 694f  
 Coagulase negative *Staphylococcus aureus* 545  
 Coagulation  
   cascade 315, 315f  
   screen 608  
   testing 607, 608  
 Coarctation 166f, 167f  
   of aorta 165, 184, 673, 674f  
 Codman's triangle 716f  
 Coeliac disease 137  
 Cognitive development 756  
 Collapsed neonate 634  
 Collection 662f  
   of blood samples 826  
 Colostomy 219  
 Communication disorders 650  
 Community acquired pneumonia 105  
 Community-based management of  
   severe acute malnutrition 83  
 Complement  
   deficiencies 517  
   function 515  
 Complete  
   heart block 183, 183f  
   versus incomplete AVSD 165f  
 Complex osteotomy model surgery 743f  
 Complications 115, 230  
 Complications of  
   childhood obesity 439t  
 Composition 781  
 Composition of  
   IV fluids 191t  
 Concentric hypo and hyperechoic layers 680f  
 Concordance 782  
 Conditions 678  
 Conduct disorder 648  
 Condylar  
   fractures 741  
   neck comminuted fractures 741f  
 Confident individuals 789f  
 Congenital abnormalities of  
   lacrimal drainage system 580  
   thoracic skeleton 104  
   upper respiratory tract 102  
 Congenital  
   adenomatoid malformation 663  
   adrenal hyperplasia 453, 454f  
   anomalies 46, 466, 717  
   brain  
   infection 694  
   malformations 685  
   cataract 9f  
   clubfoot 466  
   CMV infection 694f  
   CSF anomalies of posterior fossa 226  
   cystic adenomatoid malformation of lung 104  
   deformity 728  
   diaphragmatic hernia 103, 104f, 205, 663  
   epulis 488  
   glaucoma 583  
   heart  
   abnormalities 162  
   disease 158t, 162, 669  
   hereditary endothelial dystrophy 584  
   hypoplastic anaemia 310  
   hypothyroidism 440  
   lobar emphysema 104, 664  
   left upper lobe 104f  
   lung abnormalities 104  
   malformations of CNS 360  
   melanocytic naevus 292f  
   mesoblastic nephroma 684  
   methaemoglobinaemia 424  
   myasthenic syndromes 385  
   nasolacrimal duct obstruction 580  
   nephrotic syndrome 343  
   pulmonary sequestration 104  
   rubella syndrome 556  
   scoliosis 471  
   spine lesions 700



- synostosis 466f  
 syphilis 497, 584, 712, 713f  
 vertical talus 468  
 Conjunctivitis 578, 579f  
 Conscious level 400  
 Constipation 141  
 Contacts 536  
 Continence 220  
 Contractures 204, 469t  
 Control of spasms 538  
 Convulsions 370, 396, 402  
 Coombs test 604f  
 Coping 642  
 Copper  
   beaten skull deformity 732f  
   deficiency 97  
 Cornea 580, 582, 583f  
 Corneal opacity 581  
 Corneal size and shape 581  
 Coronal 664f  
 Corpus callosum 686f  
 Correct electrolyte imbalance 79  
 Correction of  
   acidosis 191  
   deformities 475, 476  
 Cortical  
   bone 713f  
   scarring left kidney 724f  
 Corticosteroids 327, 525  
 Costochondral junctions 90f  
 Cover-up test 474f  
 Cradle cap 290f  
 Cranial  
   nerve 14  
   sutures 7  
 Craniofacial  
   clefting defects 732  
   deformity 728  
   microsomia 732  
 Craniopharyngioma 696, 696f  
 Craniosynostosis 361, 728f, 729f  
 Cranium 746f  
 Creeping eruption 133  
 Crohn disease 134t, 135, 136f  
 Cromoglycate 524  
 Cross table lateral invertogram 217f  
 Crossed fused renal ectopia 719, 720f  
 Croup 105, 631  
 Crouzon deformity 731f  
 Crouzon syndrome 731f  
 Crusted infection 289f  
 Crypt abscess formation 135f  
 Crypts 137f  
 CSF  
   anomalies of posterior fossa 226  
   leak 745f  
 Culture 615  
   urine 614  
 Cushing's syndrome 451, 452f  
 Cushingoid syndrome 334f  
 Cutaneous tissues 712f  
 Cutaneous variety 133  
 Cut-down infusion 830  
 Cyanosed newborn 184  
 Cyanosis 672f  
 Cyanotic  
   child with heart disease 672  
   heart disease 34, 169  
 Cyclosporin A 328  
 Cystic  
   degeneration 683f  
   dilatation of fourth ventricle 686f  
   fibrosis 112, 124f, 139, 658  
   complications 115  
   diagnosis 113  
   gut disease 115  
   liver disease 115  
   mutations 112  
   related diabetes 115  
   therapies 115  
   PVL 692f  
   tumour 698f  
 Cyst 232, 485f, 488f  
 Cystic  
   adenomatoid malformation of lung 104  
 Cystinosis 584, 585f  
 Cytokine 515  
 Cytomegalovirus 576  
 Cytotoxic T cells 512  
**D**  
 Dacryocystitis 580f  
 Dactylitis of second toe 326f  
 Daily doses for leprosy 551t  
 Dandy-Walker malformation 686, 686f  
 Dangers of play deprivation 757  
 Dates 484f  
 DCIA free flap 735f  
 Deficiencies 517  
 Deficiency 97  
 Deformities 462, 475, 476  
 Deformity 468f, 706f, 728, 729f  
 Degeneration 683f  
 Deformities  
   in orthopaedic clinic 463t  
 Deformities of  
   clubfoot 466t  
   vertical talus 569t  
 Dehydration 190  
 Deletion syndromes 67  
 Delivery period 5  
 Demarcation 487f  
 Dengue fevers 559  
 Dens  
   evaginatus 500  
   in dente 500  
   invaginatus 500, 500f  
 Dense  
   plasmacytic infiltrate 137f  
   sclerosis 716f  
 Dental  
   anatomy 484  
   effects of  
     cleft lip 490  
     cleft palate 490  
   history 503  
 Dentigerous cyst 750f  
 Dentine dysplasia 502  
 Dentinogenesis imperfecta 501, 502f  
 Dentistry 484  
 Dentoalveolar  
   fractures 745f  
   trauma 502  
 Dermal melanocytosis 285  
 Dermatology 279  
 Dermatomyositis 712, 712f  
 Dermatoses 83  
 Dermoid cysts 295, 296f  
 Dermoids on cornea 583  
 Description of  
   disease 1  
   forms of play 753  
 Desquamation of thumb 338f  
 Detection of complications/monitoring 611  
 Development 23  
 Developmental  
   changes in  
     haemoglobin synthesis 305  
   delay 764  
   dysplasia of hip 469, 707  
   history 187  
   problems 472  
   steps in normal child 395t  
 DHF 560  
 Di George syndrome 516  
 Diabetes 628  
   in pregnancy 44  
   insipidus 435  
   mellitus 456, 457t  
 Diabetic ketoacidosis 628  
 Diagnosis of  
   cerebral palsy 390  
   diabetes mellitus 457t  
   immune deficiency 514  
 Diagnostic tests in tuberculosis 548t  
 Diaphragm 676, 676f  
 Diaphragmatic hernia 103, 104f, 205, 663  
 Diaphyses of femurs and tibiae 713f  
 Diarrhoea 149, 151  
 Diarrhoea 151  
   pathogens and clinical syndromes 150t  
 Diastematomyelia 701, 701f  
 Diet selection 154  
 Difficile 538  
 Differences  
   in appearance between primary and  
     permanent dentition 485f  
   between  
     adults and children in emergency  
     department 618  
     primary and permanent teeth 485  
 Differential diagnosis of  
   arthralgia 324t  
   arthritis 324t  
   exanthematous fever 554t  
   haematuria 346t  
 Diffuse bowel wall infiltration 685f  
 Dilatation of  
   fourth ventricle 686f  
   urinary tract 722  
 Dilated  
   cardiomyopathy 180  
   loops of bowel 126f

- Dimensions with scoring key to measure gross motor function 774t
- Dimercaptosuccinic acid 718f
- Diphtheria 533
- Diploic space 306f
- Dipping 797f
- Dipstick testing 614, 614f
- Directly observed treatment short course (DOTS) 549
- Disabilities 390
- Disability 627, 763f, 763t  
assessment of neurological function 401
- Disaccharide intolerance 130
- Discharge planning 50
- Diseases 1  
associated with protein-losing enteropathy 144t  
caused by group A streptococcus 542t  
of nervous system 360  
progression 113
- Disintegrating battery 409f
- Dislocation of lens 587
- Disorder of sex development 456t
- Disorders of  
amino acid metabolism 416  
branched-chain amino acid metabolism 420  
cornea 582  
emotion and behaviour 639  
motor presentations 651  
pigmentation 283  
posterior pituitary 435  
purine and pyrimidine metabolism 423  
sex development 455  
specific sugars 421  
sulphur-containing amino acids 421
- Disseminated intravascular coagulation  
consumption coagulopathy 317
- Distal  
left femoral diaphysis 716f  
renal tubular acidosis 354  
trachea 675f
- Distended  
appendix 679f  
stomach 678f
- Disturbances of  
amino acid metabolism 419  
nutrition 89
- Distraction osteogenesis 737f
- DNA  
sequencing 71  
structure 69f  
transcription 70f  
translation 70f  
vaccines 526
- Domestic violence 791
- Dosage 620t
- Dosage dilemmas 782
- Dose calculation 782
- Dosing 616
- Double  
aorta 177f  
aortic  
arch 675  
knuckle 167f  
bubble appearance 676f  
teeth 499
- Down's syndrome 62
- Drowning and near drowning 411
- Drug treatment of asthma 110
- Drug-induced gingival overgrowth 490
- Drugs 620t
- Drugs and associated toxic effects 401t
- DSS 560
- D-transposition of great vessels 672
- Duchenne's muscular dystrophy 383
- Duct closure 166f
- Duct-dependent  
cardiac lesion 634  
pulmonary circulation 169f  
systemic circulation 168f
- Duodenal  
atresia 676  
diaphragm 676, 676f  
jejunal flexure 675f, 677f
- Duodenitis secondary to NSAIDs 328f
- Duodenum 676f, 677f
- Duplex kidney 718f
- Duplication cyst of oesophagus 665f
- Duplications 67
- Dysautonomia 385, 584
- Dysgenesis 442f
- Dyskinetic cerebral palsy 389f
- Dysmorphological presentations 416
- Dysplasia 471f  
of hip 469, 707  
of left maxilla 752f
- Dystonia 770f
- Dystonic posture 378f
- Dystrophia myotonica 384
- E**
- Ear, nose and throat 102
- Early  
childhood 24, 754  
caries 487  
complications 230  
diagnosis of cerebral palsy 390  
distraction osteogenesis 737f  
neonatal infection 54f  
nursing caries 487
- Ears 8
- Eating disorders 649
- Ebstein's anomaly 173, 174f, 175f, 674
- Echogenic  
choroid plexus 690f  
kidney 721f
- Ectopic right kidney 720f
- Ectrodactyly 62f
- Eczema 288  
herpeticum 290
- Effects of  
hypothermia on babies 58t  
zinc on diarrhoea 87
- Effective contributors 789f
- Effective handwashing 824f
- Ehlers-Danlos syndrome 13
- Elbow crutches 768f
- Electric prosthesis 779f
- Elimination 781  
disorders 646  
measures 402
- Elliptocytosis 306f
- Emergencies 618, 628, 630f
- Emergency  
dosage 620t  
drugs 620t  
management of  
anaphylaxis 633f  
room management 200  
treatment 195, 503
- Emesis 401
- Emotion and behaviour 639
- Emotional  
abuse 793  
and neglect 792  
disorders 644  
issues stemming from trauma 758  
states 792  
unexplained symptoms 643
- Emphysematous left upper lobe 664f
- Empyema 659, 659f, 669f
- Enamel  
dentine 504f  
Enamel hypoplasia 501
- Encephalitis 364
- Encephalocoele 733f
- Encephalomalacia 694f
- Encephalopathy 364, 365
- Encephalopathy  
with acidosis 415  
without acidosis 415
- Encopresis 646
- Endemic iodine deficiency 440
- Endocarditis 617
- Endocrine disorders 434
- Endoscopic procedures 247
- Endoscopy 849
- Endotracheal  
intubation 848  
tube malposition 662
- Enema reduction 680f
- Energy requirements for infants 191
- Enteral feeding 154
- Enteric fever 538
- Enteritis 326f  
related arthritis 326
- Enthesopathic 326f
- Enuresis 646
- Environmental  
causes 393  
enamel hypoplasia 501  
hypomineralisation 501
- Eosinophils 510
- Ependymoma 698
- Epidermal naevi 285
- Epidermolysis bullosa 286, 491, 492f
- Epiglottitis 105, 631
- Epimerase deficiency 423
- Epinephrine 525
- Epiphyseal  
dysgenesis 442f  
height 709f
- Epiphyses around knee 316f

- Epiphysis 710f  
 Epispadias 247  
 Epithelial type 268  
 Epithelialisation 199  
 Epstein's pearls 487  
 Epulis 488, 488f, 489  
 Equinus 466f  
 Eradication of  
   *C. diphtheriae* 534  
   *C. tetani* 538  
 Eruption  
   cyst 485f  
   dates 484f  
 Erysipelas 542  
 Erythema  
   multiforme 294, 492f  
   nodosum 294, 294f  
 Erythematous  
   maculopapular rash 553f  
   papules 332f  
 Erythrocytes 422f  
 Escharotomy and fasciotomy 200  
 Estimated average requirement 87t  
 Evaluation of  
   bladder 222  
   bowel 222  
   brainstem function 222  
   cataract 586  
   hydrocephalus 222  
   lesion 222  
   lower cranial nerves 222  
   lower limb power 222  
   reflexes 222  
   tone 222  
 Event-free survival 277f  
 Events 528  
 Ewing sarcoma 668, 717  
   left femur 717f  
 Ewing's tumour 481f  
 Examination of  
   ear, nose and throat 102  
   faeces 616  
 Exanthematous fever 554t  
 Exchange transfusion 848  
 Excipients 784  
 Excoriated eczema of face 289f  
 Exercise induced anaphylaxis 521  
 Exomphalos 65f  
 Exposure 401, 627  
 Exstrophy of bladder 247  
 Extemporaneous dispensing 784  
 Extensive intraventricular haemorrhage 691f  
 Extent of  
   burn 199  
   child neglect 787  
 External jugular vein 826  
 Extracorporeal membrane oxygenation in CDH 205  
 Extracranial sites 276  
 Extra-dartos pouch-conventional orchiopexy 251  
 Extradural haematoma 689f  
 Extremities 268  
 Extrusive injury 505f  
 Eye movements 571  
 Eyes 8
- F**  
 Fabricated and induced illness 799  
 Face 9  
 Facial  
   appearance 62  
   asymmetry 65  
   clefts 228f  
   deformity 729f  
   skeleton 746f  
 Facies and gross hepatomegaly 425f  
 Facility-based management of severe acute malnutrition 77  
 Facioscapulohumeral muscular dystrophy 384  
 Factor assays 609  
 Factors  
   affecting immune response 528  
   associated with RDS 57t  
   for sex assignment 255  
   occurring before laboratory 612  
   responsible for testicular descent 250  
   developing into  
     successful learners 789f  
     confident individuals 789f  
     responsible citizens 789f  
     effective contributors 789f  
 Faecalith 126f, 678f  
 Faeces 616  
 Falx cerebri 686f  
 Familial  
   dysautonomia 385, 584  
   microcephaly 361f  
 Fanconi-type familial aplastic anaemia 311  
 Fat line cell 126f  
 Favourable histopathology 262  
 Febrile seizures 375  
 Female external urethral meatus 836f  
 Femoral  
   anteversion 464f  
   neck 709f  
   vein 826  
 Fermentative diarrhoea 130  
 Fetal  
   cardiac ventricular disproportion 206  
   circulation 35f  
 Fibroepithelial polyp 489, 490f  
 Fibrosis 112, 124f, 139, 658  
 Fibrous  
   bands 685f  
   dysplasia of left maxilla 752f  
   epulis 489  
   fibroepithelial polyp 489  
 Filiform papilla 338f  
 Film 306f, 596  
 Fine motor and vision 15, 16  
 Finger clubbing in cystic fibrosis 12f  
 Finger tip bruise 795f  
 Finger-shaped villi 137f  
 Fingertip marks 795f  
 First aid and resuscitation 410  
 First branchial cleft anomalies 230  
 First-degree burn 198  
 Fish technique 68f
- Fixed flexion deformity 778f  
 Flaccid paralysis 368, 368f  
 Flail segment 196  
 Flared eczema of hands 289f  
 Flared iliac bones 704f  
 Flat acetabular roofs 704f  
 Flat nasal bridge 62f  
 Flatfoot 472  
 Flattened vertebrae 702f  
 Flexed and adducted lower limb 389f  
 Flexible flatfoot 472, 472f  
 Florid rickets 91f  
 Fluid  
   and electrolyte balance 359  
   levels in small bowel 678f  
   management 189  
   resuscitation in paediatric burns 201  
   therapy 357  
 Fluoride 99  
 Fluoroscopy 656  
 Fluorosis 501f  
 Flush technique 828  
 Focal seizures 372  
 Foetal valproate syndrome 62f  
 Foil splint 506f  
 Folate deficiency 96, 302  
 Folds in napkin area 290  
 Fontan repair 176f  
 Fontanelle tap 826  
 Food allergy 520  
 Foot of a child with metatarsus adductus 468f  
 Foot ulcer 775f  
 Footwear 776f  
 Foramen magnum 687f  
 Force trauma 794f  
 Forced  
   dipping 797f  
   hand slap injury 794f  
   impact trauma 795f  
   trauma 795f  
 Forehead rash 331f  
 Foreign bodies 128  
 Foreign body  
   in airway 622  
   inhalation 118  
 Forms of play 753  
 Formulation 785  
 Fourth branchial cleft anomalies 231  
 Fourth-degree burn 199  
 Fowler-Stephens technique 251  
 Fracture mandible 743f  
 Fractured malar 748f  
 Fractures 192, 741, 745f, 748, 796  
 Fraenkel's white lines 93f  
 Free fluid 682f  
 Frog leg 710f  
 Frontal  
   infarcts 377f  
   lobe 694f  
 Full blood count 515, 596  
 Fungal infection 287, 498  
   of groin area 288f  
 Funnel-chest 10f  
 Future developments 526

- G**
- G6PD/oxidative damage 599
  - Gait 15, 766f
    - abnormalities 462, 463t
  - Gaiters 766f
  - Galactokinase deficiency 422
  - Galen malformation 688f
  - Games 761f
  - Gasless right iliac fossa 678f
  - Gastric lavage 401
  - Gastrocnemius 477f
  - Gastroenterology 121
  - Gastrointestinal
    - bleeding 122t
    - disease 121
    - haemorrhage 122
    - system 14, 46
    - tract 508
  - Gastro-oesophageal reflux 108
    - disease (GORD) 121
  - Gaucher disease 427
  - Generalised seizures 371
  - Genetic
    - causes 392
    - markers 264
    - tests 515
  - Genetics 59, 261
    - of stature 21
  - Genital and reproduction problem 248
  - Genitourinary system 3
  - Gentamicin monitoring single daily dose regimen 617
  - Genu
    - recurvatum 13
    - valgum 90f, 473f
    - varum 90f, 473f
  - Germ cell tumours 271, 271f, 666
  - German measles 496
  - Gestational age at diagnosis 206
  - Giant
    - cell granuloma 493f
    - congenital hairy-pigmented naevus 292f
  - Giardiasis 567
  - Giemsa-banded chromosomes 64f
  - Gingival
    - cyst 488f
    - hyperplasia 9
    - swelling 491f
  - Gingivostomatitis 495f
  - Gland 450
  - Glaucoma 583, 587
  - Globin chains of normal haemoglobins 305t
  - Globular cardiomegaly 674f
  - Globus pallidi 389f
  - Glomerulonephritis 340t
  - Glucose 837
    - 6-phosphate dehydrogenase deficiency 309
  - Gluten-sensitive enteropathy 137
  - Glycogen storage disorders 424
  - Glycogenesis 424
  - Glycogenolysis 424
  - Glycogenesis of heart 426
  - GM1 gangliosidosis 429
  - GM2 gangliosidosis 428
    - GnRH-analogue treatment 451t
    - Goitre in Hashimoto's thyroiditis 13f
    - Goldenhar syndrome 733f
    - Gonads 448
    - Gonococcal conjunctivitis 576
    - Gottron's papules 332f
    - Gower's sign 15
    - Grade 2 vesicoureteric reflux 723f
    - Grade 4 haemorrhage 691f
    - Grading of heart murmurs 159t
    - Gram's stain 842
    - Granular appearance 607f
    - Granuloma
      - annulare 293, 293f
      - lamina propria 136f
    - Granulomatous disease 516
    - Grey-white matter differentiation 693f
    - Groin incision cord clamping 274f
    - Gross
      - classification 206f
      - liver dysfunction 416
      - motor 15
      - rectal dilatation 143f
    - Growth 359, 790f
      - and development 87
      - failure of limb 335f
      - hormone 21
    - Guerin fracture 745f
    - Guidelines for post-exposure treatment of rabies 559t
    - Guillain-Barre syndrome 369
    - Gut disease 115

**H**

    - Haemangioma 489, 489f
      - of left mandible 752f
      - of airways 103
    - Haematological
      - disorders 45, 299
      - finding in disseminated intravascular coagulation 608t
      - investigations 596
      - procedures 840
    - Haematology 42
    - Haematopoiesis 299, 299f
    - Haematuria 346
    - Haematuria 346t
    - Haemithorax 659f
    - Haemoglobin 299
      - synthesis 305
      - transfusion formula 191
    - Haemoglobinopathies 308
    - Haemolytic
      - anaemias 303, 309, 713
      - uraemic syndrome 356
    - Haemophilia 316
    - Haemophilus influenzae* 544
    - Haemorrhage 122, 691f
    - Haemosiderin deposition 316f
    - Halo naevus 293, 293f
    - Hand
      - function 772f
      - hygiene 824
      - products 825
      - summary 825t
      - slap 795f
        - injury 794f
    - Hand, foot and mouth disease 496
    - Hand-Schuller Christian disease 751f
    - Handwashing 824
    - Hashimoto thyroiditis 443
    - Head 7, 192
      - and neck 267
      - anterior fontanelle 7
      - injury 634
      - injury 689
      - trauma 195
    - Healing wound 198f
    - Health consequences in adulthood 799
    - Hearing and speech 15-17
    - Heart
      - abnormalities 162
      - block 185
      - disease 176, 669
      - failure
        - by age 158t
        - in infants 184
      - rhythm abnormalities 181
    - Height 709f
    - Heliotrope discolouration 331f
    - Hemicords 701f
    - Hemiplegic cerebral palsy 389f
    - Hemisphere 389f
    - Henoch-Schönlein purpura 315, 336, 337f
    - Heparin 609
    - Hepatic metabolism 781
    - Hepatitis
      - A 145
      - B 145
      - C 146
      - caused by other viral agents 147
      - D 146
      - delta hepatitis 146
      - E 146
      - G 147
    - Hepatoblastoma 268, 269f, 667f, 684, 684f
    - Hepatocellular
      - carcinoma 270
      - degeneration 584
      - Wilson's disease 584
    - Hepatological presentation 416
    - Hepatology 121
    - Hereditary
      - endothelial dystrophy 584
      - fructose
        - intolerance 423
        - 1,6-bisphosphatase deficiency 423
      - haemolytic jaundice 303
      - motor-sensory neuropathies 382
      - spherocytosis 306f
    - Hereditodegenerative ataxias 382
    - Herniotomy 242
    - Herpangina 496
    - Herpes
      - labialis 495f
      - simplex 298f, 495, 577
      - infections 298
      - varicella-zoster 495
    - Herpetic lesions 495f

- Hiatus 668f
- High  
and intermediate level arm 219  
level concerns 800  
platelet counts (thrombocytosis) 607  
white cell counts (leucocytosis) 606
- Hilar adenopathy 658f
- Hip  
abnormalities 707  
and trunk extensors 766f  
pain in children and adolescence 482
- Hirschsprung's disease 212
- Histamine 519
- Histopathology classification of germ cell tumours 272t
- Hodgkin's  
disease 321f  
lymphoma 321
- Holoprosencephaly 686, 686f
- Homocystinuria 421, 588f
- Homozygous beta-thalassaemia 306f
- Hook grasp 773f
- Hookworms  
ankylostoma duodenale 131  
necator americanus 131
- Horizontal  
acetabula 702f  
sacrum 703f
- Horseshoe kidney 718, 719f
- Host factors 528
- Human  
immunodeficiency virus infection (AIDS) 561  
papilloma virus vaccine (HPV) 530
- Humoral agents 509  
immunoglobulins 510
- Hurler's syndrome 430f, 705, 706f
- Hydranencephaly 843f
- Hydrocephalus 222, 223, 367f, 691f, 695, 696f, 698f, 699f, 700f
- Hydrocoele 243
- Hydrodynamics 244
- Hydronephrosis 244
- Hymenolepis  
dwarf tapeworm 134
- Hyper IgE (Job's) syndrome 517
- Hyperdontia 498
- Hyperchoic mass 684f
- Hyperextensible skin 13f
- Hyperglycaemia 838, 838r
- Hyperinflated left upper lobe 664f
- Hyperinflation 114f
- Hyperkalaemia 357
- Hyperlucent large hemithorax 661f
- Hypermetabolic response 203  
and nutrition 203
- Hyperparathyroidism 446
- Hyperphosphataemia 358
- Hyperplasia 9
- Hyperplastic crypts 137f
- Hypertelorism 62f, 733f
- Hypertension 346, 348t, 349, 358, 359
- Hypertensive emergencies 349
- Hyperthyroidism 443
- Hypertonia 768f
- Hypertrophic  
cardiomyopathy 180, 185  
pyloric stenosis 209f, 678  
scar 204
- Hypertrophy 720f
- Hypertyrosinaemia 419
- Hypocalcaemia 358
- Hypochromic microcytic anaemia 598
- Hypodontia 499
- Hypoglycaemia 416, 460, 460r, 628, 838, 838r
- Hypogonadism 448, 448r
- Hypointense cystic tumour 698f
- Hypomelanosis 283f  
of ITO 284
- Hypomineralisation 501
- Hyponatraemia 357
- Hypoparathyroidism 445
- Hypophosphataemic  
rickets 351f  
vitamin D-resistant rickets 351  
phosphaturic rickets 351
- Hypophosphatasia 502
- Hypopigmented macule 380f
- Hypopituitarism 434, 434t
- Hypoplasia 501f
- Hypoplastic 708f  
anaemia 310, 312  
cerebellar vermis 686f  
left heart syndrome  
nails 63f  
other forms of univentricular heart 174
- Hypospadias 253f
- Hypothermia  
and hypoglycaemia 57  
on babies 58r
- Hypothyroidism 439, 440, 440r
- Hypovolaemia 342
- Hypoxic ischaemic encephalopathy 30
- I**
- Iatrogenic hypercorticism 334f
- Ibuprofen 404
- Ichthyosis 297
- Idiopathic  
childhood constipation 141  
generalised glycogenosis 426  
thrombocytopenic purpura 313, 314f
- Iliac crest bone 275f
- Image guided therapeutic procedures 656
- IMCI protocol for recognition and management  
of diarrhoea 152f
- Immaturity of organ function 39
- Immediate  
hypersensitivity and anaphylaxis 520  
management of preterm infant 38
- Immune  
deficiency 513  
system 508
- Immunisation 527  
against infectious diseases 527  
history 187  
schedule 531r
- Immunity 546  
and allergy 508
- Immunodeficiency 516
- Immunoglobulin 513f  
and classes 511f  
assays 515
- Immunological response to burn injury 200
- Immunology of allergic diseases 518
- Immunotherapy 525
- Impact trauma 795f
- Impalpable undescended testes 251f
- Impetigenised atopic eczema 288f
- Impetigo 288, 542f, 798f
- Importance of play 753
- Inactivated polio vaccine 530
- Inborn errors of  
metabolism 634  
lipid metabolism 427  
metabolism 43, 413
- Incontinence of urine 248
- Increase cerebrospinal fluid absorption 227
- Indications for surgery 245
- Indicators of haemolysis 604r
- Induction therapy 320
- Infant of diabetic mother 44
- Infant VSD 183
- Infantile  
colic 125  
haemangioma 281f  
of neck 281f  
hypertrophic pyloric stenosis 209  
spasms 371
- Infants 166
- Infarct 693f
- Infarction 692
- Infection 694  
control 201  
in acute renal failure 358  
of cornea 582
- Infections 496, 562, 657f, 712, 738  
of bone and joints 478  
of nervous system 361  
tumours and hydrocephalus 694
- Infectious  
complications 342  
diarrhoea 130, 149  
diseases 533  
mononucleosis 496
- Infective endocarditis 178, 185
- Inflammatory  
arthritis 326  
bowel disease 134, 330  
joint and muscle conditions 711
- Influenza vaccine 529
- Information sources 782
- Infraocclusion of upper left primary molars 486f
- Infraorbital  
crease 62f  
nerve branches 748f
- Inguinal hernia 242f  
and hydrocoele 241  
and undescended testes 248
- Inhaled foreign body 659
- Inheritance 60
- Inherited disorders  
in developing world 57r  
of bone 479

- Injectable epinephrine 525  
 Injuries 118, 636  
   accidental trauma 582  
   hard dental tissues and pulp 503  
   mark on inner surface of cheek 193*f*  
   periodontal tissues 504  
   permanent dentition 503  
   primary dentition 503  
   supporting bone 506  
 Innate immune system 510  
 Innocent murmurs 159  
 Insect stings 411  
 Inspidus 435  
 Inspection 157  
 Instruments 833  
 Insufficiency 452  
 Insulin treatment 458  
 Intelligence tests 396  
 Intensive supportive care 538  
 Intercondylar notch 316*f*  
 Interfascial calcification 332*f*  
 Intermediate uveitis (pars planitis) 590  
 Internal carotid 376*f*  
 Internal carotid artery 377*f*  
 Internal fixation 743*f*  
 International classification 215*t*  
 International immunisation endeavours 530  
 International society of paediatric oncology 270*f*  
 Interpediculate distance 703*f*  
 Interpersonal behaviours 793  
 Interpretation of CSF findings 615*t*  
 Interrupted and mattress sutures 833  
 Intersex disorders 253  
 Interstitial pulmonary oedema 663*f*  
 Intervertebral foramina 668*f*  
 Intestinal polyps 125  
 In-toeing gait 464  
 Intra-injury 797  
 Intracranial tumours 276  
 Intraepithelial spaces 137*f*  
 Intrahepatic mass 685*f*  
 Intraoral examination 503  
 Intraosseous needle 830*f*  
   insertion 830, 831*f*  
 Intrapulmonary metastases 725*f*  
 Intrathoracic meningocele 665*f*  
 Intrauterine  
   growth restriction or retardation 37  
   infectious diseases 574  
 Intravenous  
   access 200  
   biphosphonate treatment 707*f*  
   cannulae in different sizes 828*f*  
   cannulation 828  
   infusion 829  
 Intraventricular haemorrhage 40, 691*f*  
 Intubation 848  
 Intussusception 235, 679, 679*f*, 680*f*  
 Invasive streptococcal disease 542  
 Invertogram 217*f*, 218*f*  
 Investigation  
   for precocious puberty 450*t*  
   of anaemia in neonates 604  
   of hypogonadism 448*t*  
   results in thalassaemia 602*t*
- Iodine deficiency 98  
 Iontophoretic method 839  
 Ipsilateral mediastinal edge 661*f*  
 Ipsilateral renal ectopia 719  
 Iridocyclitis 325*f*  
 Iron  
   deficiency 85, 599, 600, 601*f*  
   nutritional anaemia of infancy 300  
   poisoning 404  
   requirements 86*t*  
 Irreducible hernia 242  
 Issues  
   in exstrophy of bladder 247  
   in practice 782  
   stemming from trauma 758  
 IUGR 55*t*  
 IV fluids 191*t*  
 IVH 58
- J**  
 Japanese encephalitis 530, 558  
 Jaundice 41, 145, 416  
 Jaw cysts 494  
 Jejunal  
   atresia 677*f*  
   biopsy  
     of small bowel mucosa 849  
   contusion 682*f*  
   flexure 675*f*, 677*f*  
   loops 675*f*  
 Joint  
   hypermobility syndrome 330  
   space 316*f*  
   stiffness 466  
 Juvenile  
   dermatomyositis 331, 331*f*, 332*f*  
   hypothyroidism 441  
   idiopathic arthritis 323, 711, 711*f*, 778*f*  
     associated uveitis 329  
   localised scleroderma 335  
   polyarteritis nodosa 339  
   psoriatic arthritis 326  
   reactive arthritis 329  
   Reiter syndrome 329  
   scleroderma 335  
   systemic sclerosis 336  
   Takayasu arteritis 339  
   tropical pancreatitis 148  
   xanthogranuloma 295, 295*f*  
     plaque type 296*f*
- K**  
 Kala azar 567  
 Kawasaki disease 185, 337, 338*f*  
 Kay's pictures 570*f*  
 Kayser-Fleischer ring 379*f*  
 Keloid scars 296, 296*f*  
 Keratic precipitates 589*f*  
 Keratoconjunctivitis 579  
 Keratomalacia 581, 582*f*  
 Kernicterus 236  
 Kidney 721*f*  
 Killed vaccines 527
- Knee  
   arthropathy 778*f*  
   brace/gaiter 778*f*  
   flexion deformity 768*f*  
 Knock knee 90*f*  
 Knuckle 167*f*  
 Krabbe's globoid body leucodystrophy 382
- L**  
 Labrum 707*f*  
 Lacerations 741*f*  
 Lacrimal  
   drainage system 580  
   system 579  
 Lactose intolerance 83  
 Lamellar cataract 585  
 Lamina propria 137*f*  
 Langerhans cell histiocytosis 320, 714  
 Language and speech development 24  
 Laparoscopy 252  
 Large left-sided effusion 107*f*  
 Larva migrans 133  
 Laryngeal papillomatosis 103  
 Laryngomalacia 102  
 Laryngoscopy 847  
 Laryngotracheobronchitis 105, 631  
 Late  
   complications 230  
   signs of syphilis 551*t*  
 Lateral  
   luxation injury 505*f*  
   thoracic collaterals 674*f*  
   ventricles 695*f*  
   view neck 13*f*  
 Latex allergy 521  
 Le Fort (green) osteotomies 731*f*  
 Le Fort  
   I 735, 745*f*  
     fractures 746*f*  
   II pyramidal fracture 745*f*  
   III craniofacial dysjunction 745*f*  
     fractures 744*f*  
     sub-cranial (red) osteotomies 731*f*  
     maxillary fracture lines 745*f*  
 Lead  
   lines 408*f*  
   Lead poisoning 407, 600, 711, 711*f*  
 Learning  
   disability 392  
   disorders 392  
 Left  
   adrenal gland 452*f*  
   and right upper lobe atelectasis 663*f*  
   atrium 670  
   body fractures 741*f*  
   capital femoral epiphysis 709*f*  
   cerebellar hemisphere 698*f*  
   cerebral hemisphere 689*f*  
   cervical lymphadenopathy 321*f*  
   chest  
     soft tissue mass 669*f*  
     wall mass 669*f*  
   clavicular fracture 706*f*  
   diaphragmatic hernia 663*f*  
   femoral diaphysis 716*f*  
   femur 717*f*

- frontal lobe tuberculoma 695*f*  
 heart volume overload 162*f*, 163*f*  
 hemithorax 664*f*  
 lobe of liver 269*f*  
 lower limb 335*f*  
 mandibular condylar neck fracture 741*f*  
 medial pneumothorax 661*f*  
 middle cerebral artery territory infarct 693*f*  
 orbital  
   displacement 744*f*  
   floor blow-out fracture 747*f*  
 paraspinal mass 668*f*  
 parietal skull fracture 689*f*  
 petrous temporal bone 715*f*  
 pleural effusion 666*f*  
 posterior mediastinal mass 668*f*  
 upper lobe 104*f*  
 ventricle 670, 670*f*  
 ventricular hypertrophy 168*f*
- Left-sided  
 empyema 107*f*  
 ureteropelvic obstruction 723*f*
- Legal system 801
- Legg-Calvé-Perthes disease 709, 709*f*  
 left hip 709*f*
- Legs 15
- Leishmania donovani 568*f*
- Lens disorders 585
- Leprosy 549, 550*f*, 584
- Leptospirosis 552
- Lesion 222
- Less frequently used vaccines 529
- Letterer-Siwe disease 321*f*
- Leukaemias 318
- Leukocoria 573*f*, 591*f*
- Leukotriene antagonists 525
- Leukotrienes 519
- Lichenification 289*f*
- Life cycle of  
   hookworm 132*f*  
   roundworm 131*f*  
   threadworm 132*f*
- Life support 620, 621*f*
- Limb  
   deformity 462*t*  
   injuries 636  
   pains 330
- Limb-girdle muscular dystrophy 384
- Limbs 11
- Linear  
   bruises 795*f*  
   craniotomies 732*f*  
   epidermal naevus 285*f*  
   scleroderma 335, 335*f*
- Lip 228, 228*f*
- Lipodermoid 583*f*
- Live attenuated vaccines 527
- Liver  
   disease 115, 121  
   herniation 206  
   transplantation 148
- Llouis-Bar syndrome 381
- Lobar emphysema 104, 664
- Local  
   anesthesia 831  
   examination 215
- Localised  
   enamel hypoplasia 501  
   morphaea on knee 335*f*
- Locomotor system 3, 15
- Logmar crowded test 570*f*
- Long  
   bones 704*f*  
   smooth philtrum 62*f*
- Loop suture 832*f*
- Loops of bowel 126*f*
- Low  
   Apgar score 53*t*  
   arm 219  
   birth weight infants 37  
   haemoglobin in infancy and childhood 598  
   platelet counts (thrombocytopenia) 607  
   white cell counts (leucopenia) 604
- Lower  
   cranial nerves 222  
   limb power 222  
   respiratory tract problems 105  
   thoracic spine 701*f*
- Lucency 662*f*
- Lumbar  
   puncture 843*f*  
   puncture (spinal-tap) 843  
   spine 703*f*
- Lumbosacral  
   meningocele 700*f*  
   meningomyelocele 220*f*
- Lung  
   abnormalities 104  
   abscess 659, 660*f*  
   contusions 681*f*  
   hyperinflation 663*f*  
   metastasis 684*f*  
   to head circumference ratio 206  
   vascularity 671*f*
- Luxation injury 505*f*
- Lyme disease 329
- Lymph node biopsy 321*f*
- Lymphadenopathy 725*f*
- Lymphangioma 489, 490*f*
- Lymphocytes 137*f*  
   function 515  
   subset quantification 515
- Lymphoma 666
- Lytic lesion 715*f*
- M**
- Macrocrania 225
- Macrocytic anaemia 602
- Macrodontia 499
- Maculopapular rash 553*f*
- Major  
   birth defects 57*t*  
   haemothorax 196  
   incidents 637
- Malar 331*f*, 334*f*  
   complex fractures 747*f*
- Malaria 88, 563
- Male urethra 835*f*
- Malformation 214, 216*f*, 217*f*, 282, 282*f*, 685  
   CNS 360
- Malignant  
   ovarian tumour 275*f*  
   tumours 481  
     of oral soft tissues 494  
   yolk sac tumour 276*f*
- Malnourished child 77
- Malrotation 210, 675  
   in a newborn 210  
   in older infants and children 211  
   with volvulus 676*f*
- Management of  
   acute  
     asthma attack 111  
     constipation 143  
     renal failure 357  
   allergy 524  
   anaphylaxis 524  
   antenatally detected hydrocephalus 226  
   burn wound 202  
   cardiopulmonary arrest 622  
   children with learning impairment 398  
   chronic constipation 143  
   cystic fibrosis 114  
   end-stage renal failure 359  
   hypertension 349  
   limb contractures and deformity 777  
   paralysis 476  
   seizures 32  
   severe  
     acute malnutrition 78  
     dehydration 153*f*  
     snake bite 410  
     spasticity 478  
     von Willebrand disease 317
- Mandibular  
   ankylosis 740*f*  
   fractures 743  
     in general 742
- Manifestations 323
- Mantoux test 548*f*, 852
- Maple syrup urine disease 420
- Marasmus and kwashiorkor 76*t*
- Marble bones 312
- Marfan's syndrome 73, 73*f*, 587*f*
- Marine stings 411
- Markers 264
- Maroteaux-Lamy syndrome 431*f*
- Marrow 319*f*  
   aspiration 840  
   trephine 841
- Mass lesion 700*f*
- Mast cells 510, 518*f*, 519
- Mastocytoma 296*f*
- Mastocytosis 296
- Maternal  
   phenylketonuria 417  
   substance 47  
   UPD 16 69*f*
- Maxilla 749*f*
- Maxillary  
   and mandibular dental spreading infection  
     738*f*  
   bony buttresses 746*f*  
   sinus 746*f*

- Maxillomandibular fixation 742f  
 Mean values for  
   body surface area 783t  
   height 783t  
   weight 783t  
 Measles (rubeola) 496, 552, 553f  
 Measurement of blood pressure 827  
 Measures 402  
 Mechanical prosthesis for eating 779f  
 Mechanism of  
   immune response 527  
   cardiac arrest 620  
 Meconium aspiration syndrome 34, 662  
 Meconium ileus 677  
 Mediastinal  
   mass 665, 666f  
   shift 665f, 669f  
 Mediastinum 662f, 667f  
 Mediators of allergic response 519  
 Medical  
   causes 660  
   indicators 798  
   problems 188  
   therapeutic agents 588  
   treatment 226  
 Medication errors 785  
 Medicinal charcoal 402  
 Medicolegal purpose 200  
 Medullar nephrocalcinosis 722f  
 Medullary calcinosis 722f  
 Medulloblastoma 696, 696f, 697f  
 Megakaryocytes 314f  
 Megaloblastic anaemias  
   folate deficiency 302  
   vitamin B<sub>12</sub> deficiency 302  
 Megaloblastic blood 302f  
 Melanocytic  
   naevi 292  
   naevus 292f  
 Melanotic neuroectodermal tumour 488  
 Melkersson-Rosenthal syndrome 491  
 Meningeal and testicular leukaemia 319  
 Meningocele 476f  
 Meningococcaemia 544f  
 Meningococcal  
   disease 543  
   vaccine 529  
 Meningomyelocele 775f  
 Mental health concerns followed up with  
   intersexuality 257  
 Mesoblastic nephroma 684, 684f  
 Metabolic  
   acidosis 358  
   bone disorders 710  
   diseases 413  
   disorders 44  
 Metabolism of vitamin D 352f  
 Metacarpal and phalangeal bones 704f  
 Metachromatic leucodystrophy 382  
 Metaphysis 710f  
 Metaphyseal  
   corner fractures of distal tibia 717f  
   ends of long bones 313f  
   fractures 797f  
 Metastases 667  
 Metatarsus adductus 467  
 Methaemoglobinemia 424  
 Methods of  
   orchiopexy 251  
   play therapy 759  
   urine collection 614  
 Methotrexate 327  
 Methylene blue stain 841  
 Metopic synostosis correction 730f  
 Mg/kg method 783  
 Microangiopathic haemolytic anaemia  
   iron deficiency 600  
   hypochromic fragments 600  
 Microbiology tests 614  
 Microcephaly 360, 361f  
 Microcolon 678f  
 Microcytic hypochromic red cells 301f  
 Microdontia 499  
 Micronutrient  
   deficiencies 75, 80, 84  
   status 84f  
 Microscopy 615  
   of urine 614  
 Microsomia 732  
 Microspherocytes 306f  
 Microvascular orchiopexy  
   testicular autotransplantation 252  
 Micturating cystourethrogram 723f  
 Middle ear infection 740f  
 Mid-face  
   maxillary fractures 744  
   distraction osteogenesis 731f  
   hypoplasia 703f  
 Midline posterior fossa mass 697f  
 Midshaft spiral fracture of right femur 707f  
 Mild  
   hypertelorism 733f  
   periarticular osteopaenia 316f  
 Mitochondrial  
   defects 431  
   inheritance 61  
 Mixed epithelial and mesenchymal type 269  
 Mode of infection 131  
 Moderate mediastinal shift 664f  
 Molecular  
   biology 266, 268  
   cytogenetics 71  
   genetic investigations 70  
   genetics 69, 258  
 Molluscum contagiosum 295, 295f  
 Mongolian blue spots 285f  
 Monitoring of  
   anticoagulant therapy 610  
   metabolic control and complications 458  
 Morphea 335, 335f  
 Morphological classification of cataracts 585  
 Morquio's syndrome 706f  
 Mortality rates 50  
 Mosaic trisomy 65  
 Mother's pregnancy 5  
 Motor  
   nerve blocks 769t  
   presentations 651  
 Mouth 9  
 Movement disorders 378  
 MRSA (methicillin-resistant *Staphylococcus aureus*) 545  
 Mucocoele 488, 488f  
 Mucocutaneous lymph node syndrome  
   kawasaki syndrome 179  
 Mucoid impaction 658f  
 Mucopolysaccharidoses 429, 584, 704  
 Mucopolysaccharidosis 583  
   Hunter syndrome 430  
   Hurler syndrome 429, 704  
   Maroteaux-Lamy syndrome 430  
   Morquio syndrome 430, 706  
   Sanfilippo syndrome 430  
   Scheie syndrome 430  
   Sly syndrome 431  
 Mucous membranes 508  
 Multicystic  
   dysplastic kidney 712f, 721, 721f  
   encephalomalacia 388f  
 Multiforme 294, 492f  
 Multiple  
   cystic lucencies in left hemithorax 664f  
   daily dose regimens 617  
   distal collaterals 377f  
   gestation 46  
   healing rib fractures 706f  
   intrasutural (Wormian) bones 706f  
   rib fractures of different ages 796f  
 Multistage orchiopexy 252  
 Mumps 496, 555  
 Mural nodule 698f  
 Muscle biopsy 854  
 Muscular dystrophy 383  
 Musculoskeletal pain 465, 465t  
 Mutations 112  
 My world triangle 788f  
 Myasthenia gravis 384  
 Myeloblasts 319f  
 Myeloid leukaemia 319f, 320  
 Myelomeningocele 700, 700f  
 Myocarditis 180, 185  
 Myoclonic seizure 371  
 Myotonic dystrophy 73, 384  
 Mysathenic syndromes 385  
**N**  
 Naevus spilus 293f  
 Nape of neck 282f  
 Napkin dermatitis 291, 291f  
 Nasal bone fractures 744  
 Nasogastric tube 833, 834f  
 Nasolacrimal duct obstruction 580  
 Natal/neonatal teeth 488  
 Natural killer cells 510  
 Neck 9, 13, 192, 709f  
   comminuted fractures 741f  
 Necrosis 683f  
 Necrotising enterocolitis 129  
 Needle driver 832f  
 Neglect 786, 790f  
*Neisseria meningitidis* 615f  
 Nematodes 131  
 Neonatal  
   anaemia 605f



- infections 52, 54f  
 jaundice 35  
 lupus erythematosus 334  
 paediatrics 28  
 period 5  
 procedures 48  
 reference ranges 613  
 resuscitation 28, 51, 53  
 screening for hypothyroidism 442  
 sepsis 47  
 surgery 205  
 tetanus (tetanus neonatorum) 537  
 thrombocytopenic purpura 314  
 thyrotoxicosis 445f
- Neonates**  
 and infants prone to infection 512  
 in developing world 51f  
 in respiratory distress 660
- Neoplastic diseases** 724  
**Nephrocalcinosis** 722  
**Nephrogenic diabetes insipidus** 353  
**Nephrotic syndrome** 342, 343, 378f  
**Nerve** 14  
**Nervous system** 3, 14, 842  
**Neural tube defect** 62f, 220  
**Neurenteric cyst** 665  
**Neuroblastoma** 261, 264f, 667, 668f, 682, 682f, 683f, 725, 726f  
**Neurocutaneous syndromes** 379  
**Neurocysticercosis** 367, 368f  
**Neurodegenerative disorders** 381  
**Neuroectodermal tumour of infancy** 749f  
**Neurofibromatosis** 71, 285f  
 von Recklinghausen's disease 379
- Neurological**  
 complications of diphtheria 534t  
 dysfunction 51t  
 presentations 415
- Neuromuscular**  
 causes of sleep disordered breathing 118  
 disorders 382
- Neuronal ceroid lipofuscinoses** 382  
**Neuropathic ulcer** 477f  
**Neuroradiology** 685  
**Neutralization of toxin** 534, 537  
**Neutropenia** 43  
**Newborn** 625f  
 and infant 225  
 birth 52  
 danger signs of infection 54t  
 health in developing countries 50  
 life support 624  
 screening for adrenal hyperplasia 454
- Newer vaccines** 530  
**Next line of defence: innate (non-specific) immunity** 509
- Niacin deficiency** 94  
**Niemann-Pick disease** 428  
**No time for play** 757  
**No visible anal opening** 216  
**Nocturnal enuresis** 354  
**Nodal metastases** 725f  
**Nodosum** 294, 294f  
**Non-accidental injury** 506, 637, 717  
**Non-purulent conjunctivitis** 338f
- Non-respiratory**  
 acidosis 191  
 alkalosis 192
- Nonsteroidal anti-inflammatory drugs** 327
- Non-tuberculous mycobacteria intradermal test** 853
- Non-typhoidal salmonellosis** 540
- Normal**  
 blood  
 picture in infancy 299  
 pressure 348f  
 flow volume loop 101f  
 haustrations 135f  
 infant 55t  
 jejunal biopsy 137f  
 m mode echocardiogram through left ventricle 161f  
 parasternal long-axis echocardiogram 161f  
 physiological parameters 193t  
 range of  
 blood pressure 619t  
 heart rate 619t  
 respiratory rate 619t  
 ranges 597  
 for FBC in infancy and childhood 598t  
 thymus 665, 665f
- Normocytic anaemia** 602, 603f  
**Nuclear cataract** 585
- Numerical**  
 abnormalities of  
 autosomes 64  
 sex chromosomes 64  
 chromosome abnormalities 64f
- Nursing caries** 487
- Nutrition**  
 and immunity 513  
 and preterm infant 39  
 in acute renal failure 358
- Nutritional**  
 history 187  
 management 458  
 rehabilitation phase 78
- Nystagmus** 573, 574
- O**
- Obesity** 438  
**Obliterans** 116  
**Obstetric brachial plexus palsy** 475  
**Obstructed flow volume loop** 101f  
**Obstruction** 246, 737f  
 with mass of faeces 143f
- Obstructive**  
 hydrocephalus 689f, 691f  
 jaundice 148  
 sleep apnoea 117
- Occipital cephalocele** 685f  
**Odontodysplasia (ghost teeth)** 502  
**Odontogenic keratocyst** 494f
- Oesophageal**  
 and gastric varices 123f  
 atresia 206, 206f  
 pH monitoring 852f  
 stricture 409f  
 varices 123
- Old and revised nomenclature of disorders of sexual development** 254t
- Older**  
 child 166, 225  
 infants and children 563
- Oligaemic lung fields** 170f
- Oligoarticular juvenile idiopathic arthritis** 324, 325f
- Ombredanne procedure** 252
- Oncology** 258
- Open**  
 bite 744f  
 loop of ileum 136f  
 pneumothorax 196
- Operations** 213
- Operative**  
 procedures 229  
 technique 208
- Ophthalmia neonatorum** 576  
 neonatal conjunctivitis 576
- Ophthalmology** 569
- Opisthotonus** 537f
- Opportunistic infections** 562
- Oral**  
 allergy syndrome 521  
 lesions in neonates and young infants 487  
 manifestations of systemic disease 507  
 pathology/oral medicine 487  
 rehydration therapy 153
- Orbit** 700f
- Orbital cellulitis** 578
- Orchidectomy** 274f
- Orchiectomy** 252
- Orchiopexy** 252
- Organic acidaemias** 420
- Ornithine** 420f
- Orofacial**  
 Crohn's disease 490  
 granulomatosis 491f  
 infection 496, 497f
- Orthopaedics** 462
- Orthopantomogram** 741f
- Ossifying fibroma** 751f
- Osteochondroma of ribs** 669
- Osteochondromata** 481f
- Osteogenesis imperfecta** 479, 480f, 502f, 706, 706f, 707f
- Osteoid osteoma** 716, 716f  
 of left tibia 716f
- Osteomyelitis** 479, 713, 739  
 of calcaneum 477f  
 proximal right humerus 713f
- Osteopaenia** 306f, 711f
- Osteopetrosis** 312, 313f
- Osteosarcoma** 481f, 716  
 of distal left femur 716f  
 of femur 716
- Osteotomy** 471f
- Otitis media** 105  
 with effusion 105
- Out-patient surgery** 189
- Out-toeing gait** 464
- Oval macrocytic red cells** 302f
- Ovarian tumour (desmoid)** 275f
- Ovary** 274

- P**
- Paediatric**
- assessment 222
  - haematuria 347f
  - maxillofacial surgery 72f
  - radiology 655
  - surgery 228
  - surgical patient 186
- Painful conditions of hip** 482t
- Palatal split** 745f
- Palate** 228, 228f, 490f
- Pallister-Killian syndrome** 65t
- Palsy** 386, 387f, 477, 765f
- Pancreas** 148
- Pancreatic fracture** 681f
- Pansynostosis** 732f
- Papilloedema** 9f
- Papules** 332f
- Paracentesis abdominis** 849
- Paracetamol**
- ingestion 404f
  - poisoning 403
- Paralysis** 475
- and pseudoparalysis 465
- Paralytic**
- conditions 475
  - gait patterns 465
- Parasitic**
- intestinal infection 131
  - worms 83
- Paratesticular rhabdomyosarcoma** 268
- Parathyroid glands** 445
- Paratracheal lymphadenopathy** 658f
- Paraumbilical hernia** 234
- Paravertebral mass** 668f
- Parenchyma** 691f
- Parental**
- learning disability 791
  - mental health 790
  - risk factors 789
  - substance misuse 789
- Parents** 223, 814
- Paroxysmal nocturnal haemoglobinuria** 310
- Passive cooling** 31
- Patch testing** 523
- Patellar tendon bearing** 776f
- Patent ductus arteriosus** 163, 163f, 164, 184, 671
- Pathogens**
- and clinical syndromes 150t
  - causing diarrhoea 149t
- Pathological findings in children and adolescents** 488
- Pathology of jaws and adjacent structures** 748
- Pathophysiology of**
- burn shock 199
  - of burns 198
- Pattern of spread** 267, 269
- Patterns of inheritance** 60f
- Pavlik's harness** 470f
- Pectus excavatum** 10f
- Pellagra** 95f
- deficiency 94
- Pelvic**
- anatomy 218f
  - bone 471f
  - injuries 636
  - kidney on DMSA scan 719f
  - recurrence 276f
- Pelvis** 765f
- Pelviureteric junction obstruction** 245f
- PEM** 75, 76t
- Pencil cells** 599
- Peptic ulcer** 123
- Per rectum** 124
- Percentage method (surface area method)** 782
- Percussion** 102
- of heart 14
- Percutaneous**
- endoscopic gastrostomy 851
- Percutaneous**
- liver biopsy 849
  - renal biopsy 845
- Peribronchial thickening** 114f
- Pericardial**
- effusion 179f
  - paracentesis 848
- Pericarditis** 179, 185
- Perinatal** 394
- injuries 33
  - transmission 562
- Perineal trauma** 194f
- Perineum** 216
- Periosteal reaction** 716f
- Periosteum** 713f
- Peripheral blood**
- film 306f
  - blood smear 301f
- Peritoneal dialysis or haemodialysis** 358
- Periungual fibroma in patient with tuberous sclerosis** 72f
- Periventricular and intraventricular haemorrhage**
- in premature infants 689
- Periventricular calcification** 694f
- Periventricular**
- hyperintensities 388f
  - leukomalacia 58f, 388f, 691
  - parenchymal haemorrhage 691f
  - white matter brain injury 58
- Permanent dentition** 484
- Peroxisomal disorders** 432
- Persistent patent ductus arteriosus** 40
- Perthes' disease** 482, 482f
- Pertussis** 536f
- whooping cough 535
- pH monitoring** 851f
- Phace syndrome** 282
- Phagocyte function** 515
- Phagocytes** 510
- Phagocytosis** 510f
- Pharmacokinetics** 780
- Phase proteins** 509
- Phenylketonuria** 416, 417f
- Phenytoin** 9
- Phimosis** 253
- Phlebolith** 679f
- Physical**
- abnormalities 394
  - abuse 506, 793
  - development 755
- Physiologic jaundice** 236
- Physiological**
- genu varum and genu valgum 473
  - parameters 193
- Physiotherapy** 114
- and occupational therapy 329
- Picture findings** 318
- Piebaldism** 284
- Pigmentation** 283
- Pigmented naevus** 292f
- Pilocytic astrocytoma** 698f
- Pityriasis alba** 283, 283f
- Place of**
- colloid 201
  - whole blood 201
- Plagiocephaly** 729f
- Plain film radiography** 655
- Planning discharge and follow-up** 189
- Plant and mushroom poisoning** 411
- Plaque** 291f
- with silvery scales 291f
- Plasmacytic infiltrate** 137f
- Plasmodium falciparum** 564f
- Plaster cast** 707f
- Platelet**
- disorders 607
  - function testing 609
- Plates** 746f
- Platyspondyly** 706f
- Play** 753
- activities 758
  - essential element in child development 755
  - medium of communication 759
  - restorative approach 762
  - role in emotional health 758
  - therapy 758
- Playroom** 759
- Plethysmograph** 101f
- Pleural**
- aspiration 846
  - based metastases 667f
  - fluid 659f
  - infection 107
- Plexiform neurofibroma** 72f
- Plotting fall of a/p** 273f
- Pneumatocoeles** 660, 660f
- Pneumatosis coli** 129f
- Pneumococcal**
- infections 543
  - vaccine 529
- Pneumomediastinum** 661f, 662f
- Pneumonia** 106, 657, 659
- Pneumopericardium** 661f
- Pneumothorax** 116, 660f, 661
- Poison identification and assessment of severity**
- of overdose 401
- Poisoning** 630
- antihistamines 405
  - digoxin 406
  - insecticides 406
  - petroleum distillates 406
  - tricyclic and related antidepressants 405
  - weed-killers 406
- Poisons with antidotes** 402t
- Poliomyelitis** 368, 368f, 475, 558

- Polyarticular juvenile idiopathic arthritis 325  
 Polychromasia 306*f*  
 Polycystic kidney disease 721, 721*f*  
 Polycythaemia 43, 604  
 Polydactyly 65*f*  
 Polygenic inheritance 61  
 Polymerase chain reaction 70, 615  
 Pompe's disease 426  
 Pontine glioma 699*f*  
 Poor vision to parents and carers 595  
 Pornography 799  
 Port-a-cath 115*f*  
 Portal vein invasion 685*f*  
 Port-wine 381*f*  
     stain 282*f*  
 Positive  
     mantoux test with  
         avian PPD 853*f*  
         human PPD 852*f*  
     transillumination 843*f*  
 Post-electrical burns 779*f*  
 Post-ankylosis deformity correction 743*f*  
 Post-arrest management 624  
 Post-balloon angioplasty 674*f*  
 Post-chemotherapy 264*f*  
 Posterior  
     cataract 586  
     cranial fossa 699*f*  
     fossa 686*f*  
     mediastinal cystic lesion 665*f*  
     pituitary 435  
     ribs 668*f*  
     sagittal anorectoplasty 219  
     spinal defect 700*f*  
     urethral valves 723, 723*f*  
     uveitis 590  
     vertebral body scalloping 703*f*  
 Post-fundoplication 852*f*  
 Post-haemorrhagic hydrocephalus 226, 691  
     in the premature infant 226  
 Postinfectious polyneuropathy 369  
 Postinflammatory hypopigmentation and  
     hyperpigmentation 283  
 Post-measles brownish pigmentation 553*f*  
 Post-meningitic hydrocephalus 225  
 Postnatal assessment of maturity 38  
 Postoperative analgesia 189  
 Post-streptococcal  
     glomerulonephritis 340  
     reactive arthritis 329  
 Post-tuberculous meningitis hydrocephalus 226  
 Potential non-accidental injuries 797  
 Practical  
     issues 783  
     procedures 821, 838  
 Pre-anaesthetic medication 188  
 Pre- and postoperative care 188  
 Precautions in patients with haematological  
     disorders 840  
 Pre-chemotherapy 264*f*  
 Precocious puberty 449, 449*r*  
 Prematurity 57  
 Prenatal diagnosis and prevention 221  
 Preoperative  
     antibiotics 188  
     care 223  
     management 207  
 Preparation for practical procedures 821  
 Presacral lymphadenopathy 682*f*  
 Prescribing  
     for children 780  
     in paediatrics 783  
 Presentation  
     and T cells 511  
     of cystic fibrosis 113  
 Pre-surgical HFM 733*f*  
 Pretend play 754  
 Pretreatment classification scheme 270*f*  
 Preventing neuropathic ulcers 476  
 Prevention of  
     bacterial meningitis 363  
     cerebral palsy 391  
     deformities 475  
     learning disorders 397  
     recurrence 538  
     relapses  
         *P. vivax* 565  
         *P. ovale* 565  
 Preventive  
     and therapeutic strategies 88  
     ophthalmology 594  
     strategies 155  
 Primary  
     and permanent teeth 485  
     and secondary brain injury 195  
     ciliary dyskinesia 116  
     dentition 484  
     glaucoma 587  
     IgA nephropathy 342  
     immunodeficiency disorders 515  
     microcephaly 360  
     molars 486*f*  
     pulmonary tuberculosis 658  
     survey 193  
 Principles of  
     chemotherapy 265  
     diagnosis 157  
     operation 223  
     radiotherapy 264  
     surgery 264  
 Probing 580*f*  
 Problems 472  
     associated with eruption 485  
     in early childhood 641  
     in resuscitation 201  
     of learning 652  
     with immune system 513  
 Production 223  
 Progress of primary infection 546  
 Progression 113  
     of PVL 692*f*  
 Prolonged diarrhoea 154*f*  
 Promotion of exclusive breastfeeding 155  
 Pronated upper limb 389*f*  
 Prone 765*f*  
 Prop up upper body 765*f*  
 Prophylactic medications 524  
 Prophylaxis 178  
 Prosthesis 253  
 Protection  
     process for all staff 804  
     standardised procedures 801  
 Protein binding 781  
 Protein-energy malnutrition 75  
 Protein-losing enteropathy 143  
 Protozoal infections 498  
 Provocation test 523  
 Proximal  
     renal tubular acidosis 354  
     tibia 474*f*  
     zone of translucency 93  
 Prune belly syndrome 251*f*  
 Pruritic papules 288*f*  
 Pseudoacetabula 708*f*  
 Pseudoclearing 661*f*  
 Pseudokidney sign 680*f*  
 Psoriasis 291, 291*f*  
 Psoriatic arthritis 326*f*  
 Psychology 619  
 Psychomotor development 394  
 Psychotic disorders 650  
 Puberty 21  
 Pubic  
     diastasis 248  
     hair ratings in boys and girls 23*f*  
 Pulmonary 658*f*  
     agenesis or pulmonary hypoplasia 103  
     artery 673*f*  
     atresia 173, 174*f*, 185  
         with ventricular septal defect 672  
     circulation 169*f*  
     interstitial emphysema 661, 661*f*  
     oligemia 672*f*  
     sequestration 104  
     stenosis 168, 184  
     tuberculosis 116  
     vascularity 673*f*  
     vasodilators 205  
 Pulp  
     fracture 504*f*  
     of finger and spring loaded lance to site 838*f*  
 Punched out "crater-like" burn 798*f*  
 Punctuate calcification 699*f*  
 Pure oesophageal atresia/long gap atresia 208  
 Purine and pyrimidine metabolism 423  
 Purpura fulminans 317*f*  
 Purpuric rash 321*f*  
     on buttocks 337*f*  
 PVL 692*f*  
 Pylorus with hypoechoic muscle 678*f*  
 Pyoderma gangrenosum 293, 293*f*  
 Pyogenic meningitis 361  
 Pyridoxine deficiency 95  
 Pyruvate kinase deficiency 309  
 Pyuria 614  
  
**Q**  
 Quality of information 612  
  
**R**  
 Rabies 558  
     vaccine 529  
 Rachitic rosary 353*f*

- Radial artery puncture 840  
 Radiation effects on children 655  
 Radio-isotope studies (nuclear medicine) 656  
 Ramstedt operation 210  
 Ranula 488, 489f  
 Rash on legs 337f  
 Recent horizontal linear bruises 795f  
 Receptor assays 515  
 Reciprocal translocations 67  
 Recognising and identifying trafficked children 800  
 Recognition of  
   child neglect 786  
   sick child and prevention of cardiac arrest 625  
 Recombinant vaccines 527  
 Reconstruction 219  
 Recording of weight of patient 200  
 Rectal atresia 217  
 Rectal prolapse 124, 124f  
 Recurrent pain 125  
 Recurvatum 13  
 Red cell 300  
   changes 600f  
   fragments 600  
   indices 596  
 Red flags 26f  
 Red reflex 587f  
 Redo cases 246  
 Reed-Sternberg cells 321f  
 Reflexes 222  
 Refluo technique 252  
 Regulation of solute and fluid 190  
 Rehabilitation 203, 204, 763  
   in brain injury 764  
   in limb deficiency 778  
   in musculoskeletal conditions 777  
   in neuromuscular diseases 777  
   in spinal cord injury 775  
   programme 764  
 Rehydration solution for malnutrition 80r  
 Reiter syndrome 330f  
 Related arthritis 326  
 Related diabetes 115  
 Relevant anatomy 835  
 Removal of cerebrospinal fluid 226  
 Renal  
   agenesis 720  
   biopsy 846  
   calculi (urolithiasis) 350  
   ectopia 719  
   excretion 781  
   failure 356-358  
   fanconi syndrome (cystinosis) 352  
   imaging 717  
   isthmus 719f  
   osteodystrophy or bone disease 359  
   parenchyma 721f  
   pyramids 722f  
   tract infection 724  
   trauma 681f  
   tuberculosis 346  
   tubular acidosis 354  
   vein thrombosis 350  
 Repair 735f  
 Repeated venous sampling 827  
 Reproducibility 612f  
 Respiratory  
   disorders 39, 45, 100  
   distress 631, 664f  
   distress syndrome 40, 57, 661  
   surfactant deficiency disorder 660  
   infections 88  
   investigations 100  
   pathogens in cystic fibrosis 114  
   system 3, 13, 846  
   tract 102, 508  
 Responsible  
   citizens 789f  
   for testicular descent 250  
 Restoring muscle balance 478  
 Restraining  
   baby 822f  
   child for examination of ear 8  
 Restraint 821  
 Restrictive flow volume loop 101f  
 Resuscitation 625, 626f  
 Reticulocyte count 597  
 Retinal haemorrhages 594f  
 Retinitis 576f  
 Retinoblastoma 591, 592f, 699  
 Retinchooroiditis 575f  
 Retinopathy of prematurity 41, 593, 594f  
 Retroperitoneal lymphadenopathy 725f  
 Retroperitoneal mass 683f  
 Retrosternal space 672f  
 Rett's syndrome 393  
 Revised nomenclature of disorders of sexual development and chromosomal pattern 257t  
 Revised trauma score 197t  
 Re-warming 32  
 Rhabdomyosarcoma 265, 669  
 Rheumatic chorea 379  
   Sydenham's chorea 379  
 Rheumatic  
   fever 185  
   heart disease 176, 670f  
 Rheumatoid rash 326f  
 Rheumatology 323  
 Rhinitis 521  
 Rib  
   contours 669f  
   hump 474f  
   notching 167f, 674f  
 Riboflavin deficiency 94  
 Ribs 313f, 669f  
 Rickets 351f, 447, 447t, 710  
 Right  
   adrenal neuroblastoma 725f  
   atrium 670  
   basal infiltrates 663f  
   capital femoral epiphysis 709f  
   condyle 741f  
   heart volume overload 165f  
   hydrocoele 243f  
   IC territory 376f  
   lobe of liver 680f  
   middle  
     cerebral artery territory infarct 693f  
     lobe on expiration 659f  
     lobe pneumonia 106f  
   renal mass 685f  
   sagittal split mandible 735f  
   sub-conjunctival haemorrhage 747f  
   upper lobe collapse or consolidation 106f  
   ventricle 670  
 Right-sided pneumothorax 117f  
 Rigid flatfoot 472  
 Riley-Day syndrome 385, 584  
 Ring-enhancing lesion 695f  
 Ringing of epiphyses 93f  
 Risk factors for gastroenteritis 149  
 Risk-related treatment 265  
 Robertsonian translocations 66  
 Rocker-bottom deformity 469f  
 Role of  
   breastfeeding 52  
   hormones 252  
   umbilical cord and skin care 54  
   diagnostic tests 611  
 Roof 705f, 706f  
 Room management 200  
 Root fractures 504f  
 Rota virus vaccine 530  
 Rotavirus immunisation 155  
 Round pneumonia 658, 658f  
 Roundworm (*ascaris lumbricoides*) 131  
 Route of administration 528  
 Routine  
   newborn examination 32  
   practical procedures 824  
 Rubella 496, 556, 556f, 575f  
   German measles 575  
   syndrome 556
- S**
- Sacral meningocele 221f  
 Sacrococcygeal 275  
   teratoma 701, 701f  
 Sacrosciatic notches 702f, 704f  
 Safe complementary feeding practices 155  
 Sagittal  
   reconstruction 679f  
   sinus-tap 826  
 Sail sign 665f  
 Salicylate poisoning 403  
 Salmon patch 282f  
 Samples 616, 825  
 Sampling 826  
 Sandhoff disease 428  
 Scabies 288, 288f  
 Scaling and hair loss 287  
 Scalp-vein infusion 829  
 Scar formation 798f  
 Scarlet fever 542  
 Scarring left kidney 724f  
 School-age play: structured or spontaneous 755  
 Sclerocornea 583  
 Scleroderma en coup de sabre 336

- Sclerosing panencephalitis 365  
 Sclerosis 716*f*  
 Scoliosis 471  
   with psoas spasm 126*f*  
 Screening  
   for cystic fibrosis 113  
   for DDH 470  
   tests 315  
 Scurvy 710, 711*f*  
 Seasonal allergic conjunctivitis 579  
   hay fever conjunctivitis 579  
 Seating and respiration 777  
 Sebaceous naevus 286  
   on scalp 286*f*  
 Seborrhoea of scalp 290*f*  
 Seborrhoeic  
   dermatitis 290*f*  
   eczema 290  
 Second branchial cleft anomalies 231  
 Secondary  
   glaucoma 588  
   microcephaly 360  
   neuroblastoma mandible 750*f*  
   survey 195  
 Second-degree burn (partial thickness) 198  
 Securing intravenous access 189  
 Sedation and analgesia for clinical procedures 822  
 Segment dysgenesis 583  
 Seizures 415, 630  
 Selection of glucometers 838*f*  
 Selenium deficiency 98  
 Semeiology 1  
 Sensation 15  
 Sensorimotor play (baby and toddler play) 754  
 Sensory changes 748*f*  
 Sepsis 628, 634  
   and meningitis in neonates 54*t*  
 Septic arthritis 478, 478*f*  
 Septum pellucidum 686*f*  
 Sequelae of nondescent 250  
 Sequencing 71  
 Serial manipulation 467  
 Serological testing 523  
 Serum cholesterol 613*f*  
 Severe  
   acute malnutrition 83  
   asthma with marked hyperinflation 109*f*  
   bilateral  
     bronchiectasis 112*f*  
     vesicoureteric reflux 724*f*  
   chronic nappy rash 787*f*  
   combined immune deficiency 516  
   cystic fibrosis lung disease 114*f*  
   encephalopathy 31*t*  
   hemifacial microsomia 733*f*  
   HFM types 735*f*  
 Severity 593  
 Sex  
   development 455  
   steroids and gonadotrophins in precocious puberty 450*t*  
   tourism 799  
 Sexual abuse recognition 798  
 Shigellosis 541  
 Shingles 496*f*  
 Shock in severely malnourished children 81  
 Shockable rhythms 624*f*  
 Short  
   ribs 703*f*  
   smooth stricture 409*f*  
   stature 436, 437, 437*t*  
 Short-limbed gait 464  
 SIADH 436*t*  
 Sickle cell  
   anaemia 599, 714  
   disease 307, 308*f*, 714*f*  
 Sickled red cell 308*f*  
 Significance of fluid management 189  
 Signs of overhydration 191  
 Single  
   gene disorders 71  
   or multiple joint involvements 323  
   palmar crease 63*f*  
   stage total reconstruction of exstrophy bladder 249  
 Site of  
   accidental versus non-accidental bruising 794*f*  
   cerebrospinal fluid absorption 224  
   primary 266  
 Size 618  
 Skeletal  
   and central nervous system 46  
   Skeletal defects 734  
   dysplasia 480, 480*f*, 702  
   radiology 702  
 Skeleton 746*f*  
 Skin  
   lesions 492*f*  
   prick testing 523, 853  
   procedure 853  
   testing 515  
 Skull 745*f*  
   deformity 728*f*  
   expansion 732*f*  
   vault 306*f*  
 Slap mark 506*f*  
 Sleep disordered breathing 117  
 Slipped capital femoral epiphysis 482, 483*f*, 709  
 SMA  
   adult type 383  
   intermediate type 383  
   Kugelberg-Welander syndrome 383  
   Werdnig-Hoffman disease 383  
 Small  
   bladder capacity 248  
   bowel  
     atresia 677  
     dilatation 677*f*, 678*f*  
   discrete cysts 721*f*  
   mid-septal muscular ventricular septal defect 161*f*  
   radiolucent nidus within bony lesion 716*f*  
   thorax 703*f*  
 Snake bite 410  
 Social  
   and emotional development 756  
   history 100  
   management 374  
 Soft tissue  
   defects 734  
   density 316*f*  
   facial injuries 746  
   mass 679*f*, 683*f*  
   release 467  
 Southern blotting 70  
 Spastic  
   diplegia 387*f*, 767*f*  
   quadriplegic cerebral palsy 388*f*  
 Spasticity 769*t*  
 Special investigations 592  
 Specific  
   chamber enlargement on plain film 670  
   common disorders 416  
   learning disability 397  
   sample timing 613  
   sugars 421  
 Speckled lentiginous naevus 293*f*  
 Specks 700*f*  
 Spherocytes 599  
 Spica cast 471*f*  
 Spiculated periosteal reaction 716*f*  
 Spina bifida 476  
 Spinal cord 700*f*  
   injury due to neural tube defects 775  
 Spinal muscular atrophy (SMA) 382  
 Spine 11  
   lesions 700  
 Splaying and fraying of ends of long bones 91*f*  
 Splenic fracture 681*f*  
 Splinting 504, 505*f*  
 Split palate 744*f*  
 Split-foot 62*f*  
 Sponge naevus 493*f*  
 Sporadic cretin 441*f*  
 Spur 701*f*  
 Squamous cell papilloma 493*f*  
 Square knot 833*f*  
 Stadiometer for  
   height measurement 20*f*  
   measurement of supine length 19*f*  
 Staged fowler-stephens technique 251  
 Staged repair 248  
 Stages of callous formation 796*f*  
 Staghorn calculus 350*f*  
 Staging of AIDS 562  
 Stains in common use 841  
 Standard operating procedure 814  
 Staphylococcal  
   infections 497, 545  
   scalded skin syndrome 286, 286*f*  
 Staphylococcus aureus 545  
 States 792  
 Status epilepticus 374  
 Stellate cataract 586*f*  
 Stem  
   cell transplantation 320  
   glioma 699, 699*f*  
 Stenosis 167, 184  
 Steps in normal child 395*t*  
 Steroid metabolism 451*f*

- Steroid-dependent idiopathic nephrotic syndrome 343
- Steroid-induced cataract 586f
- Steroid-resistant idiopathic nephrotic syndrome 343
- Stomach 678f
- Stones 248
- Stool examination 151
- Storage conditions 528
- Strabismus 573
- Strawberry tongue 338f
- Streptococcal infection 497, 541
- Streptococcus pneumoniae* 616f, 658f
- Stridor 667f
- Stroke 375
- Stroke 376t
- mimics 376
- Strongyloidiasis (*strongyloides stercoralis*) 132
- Structure of normal skin 279f
- Structured approach to management 619
- Sturge-Weber syndrome 380, 381f, 489, 489f, 687, 687f
- Subdural
- haematoma 690f
- haemorrhage 845f
- puncture (subdural-tap) 844
- Subependymal nodules 688f
- Subglottic stenosis 102
- Submandibular rhabdomyosarcoma 266f
- Sub-periosteal
- dissection 743f
- haematoma 93f
- Subtypes of juvenile idiopathic arthritis 323
- Sub-unit vaccines 527
- Successful learners 789f
- Sudden infant death syndrome 118
- Sulphasalazine 328
- Sulphur-containing amino acids 421
- Superficial veins 826
- Superior mesenteric artery and vein 676f
- Supernumerary teeth 499f
- Support care 32
- Supportive
- care 319
- therapy 534
- treatment 563
- Supraclavicular narrowing 377f
- Suprapubic aspiration (bladder-tap) 845
- Supraventricular tachycardia 181, 181f, 185
- Surface intra-epithelial lymphocytes 137f
- Suture
- needle 832f
- placement 832f
- Sutures 7
- including type and size of sutures 831
- Suturing 831
- Swallowed foreign bodies 409
- Sweat test 839
- chloride sweat test 839
- cystic fibrosis sweat test 839
- Swelling 491f, 693f
- of both knees 325f
- of right ankle 325f
- Swollen
- hands 787f
- lower legs 787f
- radial epiphyses 90f
- Symptoms of thyroglossal duct cyst 233
- Syndrome of inappropriate antidiuretic hormone secretion 436
- Synechiae 589f
- Synostosis 466f, 729f
- Synthetic disease-modifying anti-rheumatic drugs 327
- Syphilis 497, 551, 576, 584, 712, 712f, 713f
- Syphygmomanometry 827
- Systemic
- circulation 168f
- diseases with corneal manifestations in childhood 584
- examination 217
- illness 130
- infections and uveitis 590
- involvement with *S. aureus* 545t
- lupus erythematosus 333, 334f
- onset juvenile idiopathic arthritis 325
- Still's disease 325
- T**
- T and B cells 519
- T helper cells 512
- Taenia echinococcus (hydatid cyst) 133
- Tall stature 438, 438t
- Talus 469f
- Tamponade 196
- Tanner-Whitehouse 435f
- Target cells 600
- Taurodontism 500
- Tay-Sachs disease 428, 428f
- T-cell lymphoma 666f
- Telangiectasia 517f
- Temporal
- bone region of skull 715f
- nerve branches 748f
- Tension pneumothorax 196
- Term IUGR/LBW 55
- Terminal reservoir 143f
- Test for humoral immunity 515
- Testicular tumour (orchidoblastoma) 274f
- Testis 273
- Tests
- of cell mediated immunity 515
- to diagnose iron deficiency 601
- to diagnose thalassaemia 601
- Tetanus 536
- Tetracycline staining 501f
- Tetralogy of Fallot 169, 170f, 184, 672
- Thalami 686f
- Thalassaemia 713, 714f
- intermedia 307
- Thalassaemias 305
- Thanatophoric dysplasia 702, 702f
- Theories on embryogenesis of neural tube defects 221
- Thermal injuries 637, 797
- Thiamine deficiency 93
- Third branchial cleft anomalies 231
- Third-degree burns 198f
- Thoracic
- 669f
- skeleton 104
- trauma 195
- vertebrae 714f
- Thoracolumbar kyphoscoliosis 703f
- Threadworm 132
- enterobius vermicularis 132
- oxyuriasis 132
- pinworm 132
- seatworm 132
- Threshold effect 61f
- Thrombocytopenic purpuras 312
- Thrombocytopenia 43
- in childhood 313t
- Thromboembolic complications 342
- Thymic sonography 666
- Thymus 662f, 665f
- and T cell immunity 512
- Thyroglossal duct cyst 233
- Thyroid gland 439
- Thyroiditis 443
- Thyrototoxicosis 444f
- Tibial puncture 841
- Time interval from primary infection 547t
- Timing of surgery 229
- Tinea capitis 287f
- Tinea corporis 287f
- Tinea cruris 288f
- Tip-toe 472f
- Tissue wasting 138f
- Tocopherol deficiency 97
- Toddler's diarrhoea 130
- Toe-walking 464
- Tone 222
- Tonic neck reflex 388f
- Tonic-clonic seizure (grand mal) 371
- Tonsillitis 105
- Tonsillopharyngeal 533
- Total
- anomalous pulmonary venous drainage 172, 173f, 673
- villosus atrophy with loss of villi 137f
- Toxic
- myocarditis 534
- neuropathy 534
- Toxoids 527
- Toxoplasma 575f
- Toxoplasmosis 565, 574
- Toys 572f
- Trace minerals 99
- Trachea 547f, 675f
- Tracheal stenosis 103
- Tracheobronchomalacia 103
- Tracheo-oesophageal fistula 206f
- with oesophageal atresia 103
- Tracheostomy 847
- Tract 508
- Trafficking 799
- Trans-cranial (blue) osteotomies 731f
- Transcription 70f
- Transcrotal orchiopexy 251
- Transfusion 191
- Transient
- neonatal thyrotoxicosis 445

- synovitis 482
- tachypnoea of newborn 34, 662
- Transillumination 842
- Translation 70*f*
- Transport 638
- Transportation of patients 188
- Transposition of great arteries 171, 171*f*, 184
- Trapping 659*f*
- Trauma score 197*t*
- Traumatic
  - acquired spinal cord injury 775
  - retinopathy 594, 594*f*
  - tap 615
  - ulceration 491
- Travel immunisation 532
- Treacher collins syndrome 736, 736*f*
- Treat/prevent
  - dehydration 79
  - hypoglycaemia 78
  - hypothermia 79
  - infection 79
- Treatable disorders 414
- Treating joint instability 475
- Treatment
  - for thyroglossal duct cyst 233
- Treatment of
  - corneal opacities in childhood 584
  - DDH
    - between age of 6 and 18 months 471
    - in children between 18 months and 3 years 471
    - infants under 6 months of age 470
  - hepatic disorders 147
  - high-risk disease 265
  - initial presentation of idiopathic nephrotic syndrome 343
  - intermediate risk disease 265
  - juvenile
    - dermatomyositis 333
    - idiopathic arthritis 327
  - low-risk disease 265
  - neonatal
    - hip instability 470
    - meningitis and sepsis 55*t*
  - ulcerative colitis and crohn disease 136
- Tricuspid atresia 172, 172*f*, 185
- Tripod pinch 773*f*
- Trisomies 65*t*
- Truancy 649
- Truncus arteriosus 673
- Trunk control 766*f*
- Tryptase 523*f*
- Tube malposition 662
- Tuberculoma 695*f*
- Tuberculosis of central nervous system 366
- Tuberculous meningitis 366, 695, 367*f*
- Tuberous sclerosis 72, 284, 380, 380*f*, 688, 688*f*
- Tubular bones 714*f*
- Tumour
  - excised 275*f*
  - markers 272
  - thrombi 685*f*
  - of bone 481
- Turner's syndrome 66*f*
- Types of
  - vaccine 528
  - biliary atresia 237
  - choledochal cysts 238
  - haemangioma 282
  - handwash 825
  - mutation 71
  - needle 833
  - sample 614
- Typhoid fever 538
- Typical overlapping fingers 65*f*
- U**
- Ulceration 491, 492*f*
- Ulcerative colitis 134, 134*t*, 135*f*
- Umbilical hernia 234
- Umblicated papules 295*f*
- Uncomplicated ureteral duplication 718*f*
- Undescended testes 249*f*
- Unrupted supernumerary teeth 499*f*
- Unexplained
  - death 44
  - symptoms 643
- Unfavourable histopathology 262
- Uniparental disomy and imprinting 67
- Univentricular heart 185
- Untreated coeliac disease 138*f*
- Upper
  - fullness 685*f*
  - airway 192
  - eyelid ptosis 731*f*
  - eyelids 331*f*
  - gastrointestinal
    - contrast study 676*f*
    - tract contrast study 209*f*
  - gi endoscopy 328*f*
  - lid corrections 731*f*
  - limb trans-radial amputee 779*f*
  - renal moiety 718*f*
  - respiratory tract 102, 105
    - infection 105
- Urea
  - breath test (*Helicobacter pylori* infections) 850
  - cycle disorders 420
- Ureteral duplication 717
- Ureterocalicostomy 246
- Ureteropelvic junction obstruction 723*f*
- Urinalysis 836
  - interpretation 837
- Urinary
  - catheterisation in male and female 834
  - system 340
  - tract 845
    - imaging 345
    - infections 248, 344
    - nephrocalcinosis 722
    - stones 722
- Urine 614
  - leak 246
  - output monitoring 201
- Urogenital tract 509
- Urology 244
- Urticaria 294, 294*f*
- Uterus 268
- Uveitis 588, 589*f*, 590
- V**
- Vaccination
  - and weaning 48
  - history 100
- Vaccine related factors 528
- Vaccines 526
- Vagina 268
- Valgum 90*f*, 473*f*
- Valgus alignment 474*f*
- Vancomycin therapy 617
- Variants diagram 174*f*
- Varicella virus (chickenpox) 556
- Various forms of abuse 786
- Various types of vaccines used for active immunisation 527
- Varum 90*f*, 473*f*
- Vascular
  - anomalies 280, 282, 751
  - ring 175, 176*f*, 177*f*
  - tumours 280
- Vasculitic syndromes 336
- Vasopressin deficiency 435*t*
- Vein of galen malformation 688, 689*f*
- Velocardiofacial syndrome 68*f*
- Venepuncture 826
- Venous access 838, 839
- Ventilation 32
- Ventilator strategies 205
- Ventilatory support 400
- Ventricular
  - puncture 845
  - septal defect 162, 162*f*, 184, 671
  - tachycardia/fibrillation 183
- Vermis 696*f*
- Vernal 579*f*
- Vernal keratoconjunctivitis 579
- Vertebral bodies 702*f*
- Vertical
  - and horizontal mid-face fracture patterns 745*f*
  - talus 468, 569*t*
- Vesicoureteric reflux 247, 345*f*, 723
- Vesiculobullous disorders 491
- Viral
  - infections 495
    - of liver 145
  - pneumonia 657
  - pneumonias 105, 657*f*
  - warts 295
- Visceral variety 133
- Visible abnormal anal opening 216
- Visual
  - acuity 569
  - measurement 570
  - assessment 569
  - functions 571
  - impairment 595*f*
  - information 572*f*

## Vitamin

- A deficiency 83
  - in childhood 84
- A supplementation
  - with immunisations 85*t*
- B deficiencies 93
- B<sub>1</sub> deficiency 93
- B<sub>12</sub> deficiency 95, 303
- B<sub>2</sub> deficiency 94
- B<sub>6</sub> deficiency 95
- C deficiency 92
- D deficiency 89
- D metabolism 89
- E deficiency 97
- k deficiency 97
- Vitiligo 283, 284*f*
- Volumatic with metered dose inhaler 110*f*
- Volved small bowel 676*f*
- Von Hippel-Lindau disease 381
- Von Willebrand disease 316
- Vulva 268

**W**

- Waddling gait 464
- Walking 462
- Wall masses 668

- Water House-Friderichsen syndrome 363
- Water-soluble contrast study 678*f*
- Wave sign 665*f*
- Wegener's granulomatosis 339
- Weights 55*t*
- Weight
  - babies 56*t*
  - height and body surface area 782
- Wet lung 34
- Wheelchair 771*f*
- White
  - cell
    - disorders 604
    - types and their disorders 606*t*
  - cells 300
  - lesions 492
  - matter 692*f*
    - oedema 695*f*
    - spectacle sign 313*f*
- Whole bowel irrigation 402
- Wilms' tumour 258, 259*f*, 683, 724, 724*f*, 725*f*
  - of left kidney 724*f*
- Wilson's disease 378, 378*f*
  - hepatolenticular degeneration 144
- Window settings 715*f*
- Wiskott-Aldrich syndrome 298, 315, 517

- Wolff-Parkinson-White syndrome 182*f*
- Wound 832*f*
  - coverage 202
  - preparation 831

**X**

- Xanthochromic subdural fluid 845*f*
- Xerophthalmia and nutritional corneal ulceration 581
- X-linked
  - agammaglobulinaemia 516
  - dominant inheritance 61
  - ichthyosis 297*f*
  - recessive inheritance 60

**Y**

- Yolk sac tumour recurrence 276*f*

**Z**

- Zinc
  - in child health 86
  - supplementation 155
- Zygomatiko-facial nerve branches 748*f*
- Zygomatiko-orbital injuries 746