

**TEXTBOOK OF  
COSMETIC  
DERMATOLOGY**  
FOURTH EDITION

**informa**  
healthcare

Robert Baran  
Howard I. Maibach

# **Textbook of Cosmetic Dermatology**

## SERIES IN COSMETIC AND LASER THERAPY

*Series Editors*

**David J Goldberg, Nicholas J Lowe, and Gary P Lask**

Published in association with the *Journal of Cosmetic and Laser Therapy*

David J Goldberg, *Fillers in Cosmetic Dermatology*, ISBN 9781841845098

Philippe Deprez, *Textbook of Chemical Peels*, ISBN 9781841842954

C William Hanke, Gerhard Sattler, Boris Sommer, *Textbook of Liposuction*, ISBN 9781841845326

Paul J Carniol, Neil S Sadick, *Clinical Procedures in Laser Skin Rejuvenation*, ISBN 9780415414135

David J Goldberg, *Laser Hair Removal, Second Edition*, ISBN 9780415414128

Benjamin Ascher, Marina Landau, Bernard Rossi, *Injection Treatments in Cosmetic Surgery*, ISBN 9780415386517

Avi Shai, Robert Baran, Howard I. Maibach, *Handbook of Cosmetic Skin Care, Second Edition*, ISBN 9780415467186

Jenny Kim, Gary Lask, *Comprehensive Aesthetic Rejuvenation: A Regional Approach*, ISBN 9780415458948

Neil Sadick, Paul Carniol, Deborshi Roy, Luitgard Wiest, *Illustrated Manual of Injectable Fillers*, ISBN 9780415476447

Paul Carniol, Gary Monheit, *Aesthetic Rejuvenation Challenges and Solutions: A Global Perspective*, ISBN 9780415475600

Neil Sadick, Diane Berson, Mary P Lupo, Zoe Diana Draelos, *Cosmeceutical Science in Clinical Practice*, ISBN 9780415471145

Anthony Benedetto, *Botulinum Toxins in Clinical Dermatology, Second Edition*, ISBN 9780415476362

Robert Baran, Howard I. Maibach, *Textbook of Cosmetic Dermatology, Fourth Edition*, ISBN 9781841847009

David J Goldberg, Alexander L Berlin, *Disorders of Fat and Cellulite*, ISBN 9780415477000

Kenneth Beer, Mary P Lupo, Vic Narurkar, *Cosmetic Bootcamp Primer*, ISBN 9781841846989

# Textbook of Cosmetic Dermatology

Fourth Edition

Edited by

Robert Baran, MD

*Nail Disease Center  
Cannes, France*

Howard I. Maibach, MD

*Department of Dermatology  
University of California San Francisco, School of Medicine  
San Francisco, California, U.S.A.*

**informa**  
healthcare

---

Philadelphia London

First published in 1994 by Martin Dunitz Ltd, London, UK.

This edition published in 2010 by Informa Healthcare, Telephone House, 69–77 Paul Street, London EC2A 4LQ, UK.

Simultaneously published in the USA by Informa Healthcare, 52 Vanderbilt Avenue, 7th Floor, New York, NY 10017, USA.

Informa Healthcare is a trading division of Informa UK Ltd. Registered Office: 37–41 Mortimer Street, London W1T 3JH, UK. Registered in England and Wales number 1072954.

©2010 Informa Healthcare, except as otherwise indicated

No claim to original U.S. Government works

Reprinted material is quoted with permission. Although every effort has been made to ensure that all owners of copyright material have been acknowledged in this publication, we would be glad to acknowledge in subsequent reprints or editions any omissions brought to our attention.

All rights reserved. No part of this publication may be reproduced, stored in a retrieval system, or transmitted, in any form or by any means, electronic, mechanical, photocopying, recording, or otherwise, unless with the prior written permission of the publisher or in accordance with the provisions of the Copyright, Designs and Patents Act 1988 or under the terms of any licence permitting limited copying issued by the Copyright Licensing Agency, 90 Tottenham Court Road, London W1P 0LP, UK, or the Copyright Clearance Center, Inc., 222 Rosewood Drive, Danvers, MA 01923, USA (<http://www.copyright.com/> or telephone 978-750-8400).

Product or corporate names may be trademarks or registered trademarks, and are used only for identification and explanation without intent to infringe.

This book contains information from reputable sources and although reasonable efforts have been made to publish accurate information, the publisher makes no warranties (either express or implied) as to the accuracy or fitness for a particular purpose of the information or advice contained herein. The publisher wishes to make it clear that any views or opinions expressed in this book by individual authors or contributors are their personal views and opinions and do not necessarily reflect the views/opinions of the publisher. Any information or guidance contained in this book is intended for use solely by medical professionals strictly as a supplement to the medical professional's own judgement, knowledge of the patient's medical history, relevant manufacturer's instructions and the appropriate best practice guidelines. Because of the rapid advances in medical science, any information or advice on dosages, procedures, or diagnoses should be independently verified. This book does not indicate whether a particular treatment is appropriate or suitable for a particular individual. Ultimately it is the sole responsibility of the medical professional to make his or her own professional judgements, so as appropriately to advise and treat patients. Save for death or personal injury caused by the publisher's negligence and to the fullest extent otherwise permitted by law, neither the publisher nor any person engaged or employed by the publisher shall be responsible or liable for any loss, injury or damage caused to any person or property arising in any way from the use of this book.

A CIP record for this book is available from the British Library.

Library of Congress Cataloging-in-Publication Data available on application

ISBN-13: 9781841847009

Orders may be sent to: Informa Healthcare, Sheepen Place, Colchester, Essex CO3 3LP, UK

Telephone: +44 (0)20 7017 5540

Email: [CSDhealthcarebooks@informa.com](mailto:CSDhealthcarebooks@informa.com)

Website: <http://informahealthcarebooks.com/>

For corporate sales please contact: [CorporateBooksIHC@informa.com](mailto:CorporateBooksIHC@informa.com)

For foreign rights please contact: [RightsIHC@informa.com](mailto:RightsIHC@informa.com)

For reprint permissions please contact: [PermissionsIHC@informa.com](mailto:PermissionsIHC@informa.com)

Typeset by MPS Limited, a Macmillan Company

Printed and bound in the United Kingdom

*Once again this book is dedicated to Nicole,  
without whom it would not exist,  
with appreciation, respect, admiration, and deep affection*

---

## Preface

The fourth edition of the *Textbook of Cosmetic Dermatology* focuses on the “evidence-based” approach to cosmetic skin, hair, and nail science. Preceding editions published contrasting observations; this edition benefits from the increasing numbers of individuals who have directed their work to controlled observations in cutaneous biology as it relates to skin care. Although this textbook was originally intended for the dermatologist, we are pleased that cosmetic scientists have found this view of cutaneous biology of value and have supported us in blending the traditional cosmetic science with skin biology.

We appreciate the hard work and suggestions of our authors and readers and welcome suggestions for a future edition.

The editorial wisdom of our publisher, Robert Peden, is greatly appreciated.

*Robert Baran*

*Howard I. Maibach*

---

# Contents

Preface . . . . . vi

Contributors . . . . . xi

## Section I: Influences on Skin

1. **Skin physiology and gender** . . . . . 1  
*Ethel Tur*
2. **A quantitative approach to anatomy and physiology of aging skin: barrier, dermal structure, and perfusion** . . . . . 14  
*Jeanette M. Kamell and Howard I. Maibach*
3. **Climatic influence on cosmetic skin parameters** . . . . . 28  
*Mathias Rohr and Andreas Schrader*
4. **Photodamage** . . . . . 41  
*Karen Connolly, Camile L. Hexsel, and Henry W. Lim*

## Section II: Cutaneous Absorption and Cosmetology

5. **Skin barrier cream efficacy: evidence based** . . . . . 47  
*Hongbo Zhai, Heidi P. Chan, and Howard I. Maibach*
6. **Using the behind-the-knee (BTK) test to evaluate lotion transfer from products to skin** . . . . . 54  
*Miranda A. Farage*
7. **Nail penetration** . . . . . 63  
*Xiaoying Hui, Ronald C. Wester, and Howard I. Maibach*

## Section III: Pharmacology of Cosmetic Products and Ingredients

8. **Sensitive skin: new findings yield new insights** . . . . . 73  
*Miranda A. Farage and Howard I. Maibach*
9. **Hyaluronan (hyaluronic acid)** . . . . . 84  
*Birgit A. Neudecker, Robert Stern, and Howard I. Maibach*
10. **Organic acids with novel functions,  $\alpha$ -hydroxy, aldobionic, N-acetylamino acids, and related compounds** . . . . . 91  
*Ruey J. Yu and Eugene J. Van Scott*
11. **Retinyl propionate and related retinoids** . . . . . 106  
*John E. Oblong*
12. **Idebenone (hydroxydecyl ubiquinone)** . . . . . 111  
*Birgit A. Neudecker, Falko Diedrich, and Howard I. Maibach*
13. **Antioxidants** . . . . . 115  
*Frank Dreher and Jens Thiele*
14. **Topical retinol: an efficacious solution for improvement of main photodamage signs** . . . . . 123  
*Christiane Bertin and Thierry Oddos*



<b>15. Applications of total soy in skin care</b> .....	<b>127</b>
<i>Jue-Chen Liu, Jeff Wu, and Miri Seiberg</i>	
<b>16. Kinetin</b> .....	<b>141</b>
<i>Stanley B. Levy</i>	
<b>17. Urokinase and dry skin</b> .....	<b>144</b>
<i>Yuji Katsuta</i>	
<b>18. Ceramides and the skin</b> .....	<b>150</b>
<i>Clive R. Harding, David J. Moore, and Anthony V. Rawlings</i>	
<b>19. Perfumes</b> .....	<b>165</b>
<i>Jeanne Duus Johansen</i>	
<b>20. Do consumer relevant exposures to geraniol cause clinical allergic contact dermatitis in man?</b> .....	<b>169</b>
<i>Jurij J. Hostynek and Howard I. Maibach</i>	
<b>21. Survey of alternative and natural drugs in dermatology</b> .....	<b>176</b>
<i>Cheryl Levin and Howard I. Maibach</i>	
<b>Section IV: Cosmetology for Non-pathological Skin</b>	
<b>22. Skin care products for normal, dry, and greasy skin</b> .....	<b>180</b>
<i>Céline Try, Laurence Nicod, and Philippe Humbert</i>	
<b>23. Self-tanning products</b> .....	<b>188</b>
<i>Stanley B. Levy</i>	
<b>24. Astringents, masks, and ancillary skin care products</b> .....	<b>192</b>
<i>Zoe Diana Draelos</i>	
<b>25. Cosmeceuticals</b> .....	<b>196</b>
<i>Marianne Nelson O'Donoghue</i>	
<b>26. Photodamage: prevention</b> .....	<b>200</b>
<i>Camile L. Hexsel and Henry W. Lim</i>	
<b>27. Photodamage: protection and reversal with topical antioxidants</b> .....	<b>206</b>
<i>Karen E Burke</i>	
<b>Section V: Cosmetology for Specific Locations and Conditions</b>	
<b>28. Hair care</b> .....	<b>218</b>
<i>John Gray and Jeni Thomas</i>	
<b>29. Dandruff and seborrheic dermatitis</b> .....	<b>230</b>
<i>James R. Schwartz, Caroline W. Cardin, Yvonne M. DeAngelis, and Thomas L. Dawson, Jr.</i>	
<b>30. The periorbital wrinkle</b> .....	<b>242</b>
<i>Martin R. Green</i>	
<b>31. Cosmetology for normal nails</b> .....	<b>247</b>
<i>Robert Baran and Douglas Schoon</i>	
<b>32. Cosmetics for abnormal and pathological nails</b> .....	<b>259</b>
<i>Douglas Schoon and Robert Baran</i>	
<b>33. Hand and body lotions</b> .....	<b>269</b>
<i>F. Anthony Simion and David C. Story</i>	

<b>34. Anticellulite products and therapies</b> .....	290
<i>Enzo Berardesca and Manuela Carrera</i>	
<b>35. Therapy of telangiectasia and varicose veins and their complications</b> .....	294
<i>Robert A. Weiss and Margaret A. Weiss</i>	
<b>36. Management of hirsutism and hypertrichosis</b> .....	302
<i>Ralph M. Trüeb</i>	
<b>37. Pigmentation: dyschromia</b> .....	311
<i>Thierry Passeron and Jean-Paul Ortonne</i>	
<b>38. Introduction to practical, aesthetic, and social approaches to appearance restoration</b> .....	330
<i>Victoria L. Rayner Alatorre</i>	
<b>39. Treatment of keloids</b> .....	341
<i>Joshua E. Lane, Tanda N. Lane, and John L. Ratz</i>	
<b>40. Keratolytic treatment of acne</b> .....	352
<i>Ali Alikhan and Howard I. Maibach</i>	
<b>Section VI: Skin Care for Specific Groups</b>	
<b>41. Cosmetics for men</b> .....	365
<i>Robert Baran and Annick Pons-Guiraud</i>	
<b>42. Ethnic cosmetics</b> .....	379
<i>Enzo Berardesca, Grazia Primavera, Manuela Carrera, and Howard I. Maibach</i>	
<b>43. Ethnic variation in hair</b> .....	386
<i>Nina Otberg</i>	
<b>44. Ethnic differences in skin properties</b> .....	395
<i>Naissan O. Wesley, Lily Talakoub, and Howard I. Maibach</i>	
<b>45. The menopause, skin, and cosmetology</b> .....	405
<i>Michel Faure and Evelyne Drapier-Faure</i>	
<b>Section VII: Cosmetological Treatments</b>	
<b>46. Mesotherapy</b> .....	410
<i>Evangeline B. Handog and Ma. Teresita G. Gabriel</i>	
<b>47. Microneedles and cosmetics</b> .....	417
<i>Raja K. Sivamani and Howard I. Maibach</i>	
<b>48. Photodynamic therapy in dermatology</b> .....	422
<i>Jacques Savary</i>	
<b>49. Topical 5-fluorouracil formulations in actinic keratosis treatment</b> .....	429
<i>Ravneet R. Kaur, Ali Alikhan, and Howard I. Maibach</i>	
<b>50. Cosmetic cryosurgery</b> .....	434
<i>Rodney D. Sinclair and Poorna Weerasinghe</i>	
<b>51. Botulinum toxins</b> .....	442
<i>Doris Maria Hexsel and Arnold W. Klein</i>	
<b>52. Soft tissue augmentation</b> .....	454
<i>Emily P. Tierney and C. William Hanke</i>	
<b>53. Bioelectricity</b> .....	466
<i>Ying Sun and Jue-Chen Liu</i>	

54. **Chemical peelings** ..... 482  
*Philippe Deprez*

55. **Lasers and light sources for vascular and pigmented components  
of photoaging** ..... 494  
*Corinne Erickson and Robert A. Weiss*

**Section VIII: Noninvasive Assessment Techniques**

56. **An easy method to assess the antioxidative capacity  
of topical formulations** ..... 503  
*Hongbo Zhai and Howard I. Maibach*

57. **The antioxidative capacity of topical emulsion on ultraviolet exposure ...** 505  
*Hongbo Zhai and Howard I. Maibach*

58. **Treatment and noninvasive clinical assessment of  
androgenetic alopecia** ..... 510  
*R. Scott Youngquist, Jeanette A. Richards, Caroline W. Cardin,  
and Thomas L. Dawson, Jr.*

59. **Assessing the efficacy of moisturizers** ..... 519  
*Whitney Hannon*

*Index* ....543

---

## Contributors

**Ali Alikhan** University of California Davis, School of Medicine, Davis, California, U.S.A.

**Robert Baran** Nail Disease Centre, Cannes, France

**Enzo Berardesca** San Gallicano Dermatological Institute, Rome, Italy

**Christiane Bertin** Skin Care Research Institute, Johnson & Johnson Group of Companies, Issy les Moulineaux, France

**Karen E. Burke** Department of Dermatology, Mount Sinai Medical Center, New York, New York, U.S.A.

**Caroline W. Cardin** P&G Beauty and Grooming, Cincinnati, Ohio, U.S.A.

**Manuela Carrera** San Gallicano Dermatological Institute, Rome, Italy

**Heidi P. Chan** Department of Dermatology, University of California San Francisco, School of Medicine, San Francisco, California, U.S.A.

**Karen Connolly** Jefferson Medical College of Thomas Jefferson University, Philadelphia, Pennsylvania, U.S.A.

**Thomas L. Dawson, Jr.** P&G Beauty and Grooming, Cincinnati, Ohio, U.S.A.

**Yvonne M. DeAngelis** P&G Beauty and Grooming, Cincinnati, Ohio, U.S.A.

**Philippe Deprez** Clinica HERA, Empuriabrava, Spain

**Falko Diedrich** München, Germany

**Zoe Diana Draelos** Department of Dermatology, Duke University School of Medicine, Durham, North Carolina, U.S.A.

**Evelyne Drapier-Faure** Gynecology, Hopital Femmes Mères Enfants, Lyon, France

**Frank Dreher** Neocutis, San Francisco, California, U.S.A.

**Corinne Erickson** Department of Dermatology, University of Maryland, Baltimore, Maryland, U.S.A.

**Miranda A. Farage** The Procter & Gamble Company, Cincinnati, Ohio, U.S.A.

**Michel Faure** Hospital Edouard-Herriot, Lyon, France

**Ma. Teresita G. Gabriel** Department of Dermatology, Research Institute for Tropical Medicine, Department of Health, Muntinlupa City, Philippines

**John Gray** Procter & Gamble Technical Centres Limited, Egham, U.K.

**Martin R. Green** Colworth Science Park, Unilever Research, Sharnbrook, U.K.

**Evangeline B. Handog** Department of Dermatology, Asian Hospital and Medical Center, Muntinlupa City, Philippines

**C. William Hanke**    Laser and Skin Surgery Center of Indiana, St. Vincent's Hospital, Carmel, Indiana, U.S.A.

**Whitney Hannon**    San Jose, California, U.S.A.

**Clive R. Harding**    Unilever Research and Development Port Sunlight Laboratory, Wirral, U.K.

**Jurij J. Hostynek**    Department of Dermatology, University of California San Francisco, School of Medicine, San Francisco, California, U.S.A.

**Camile L. Hexsel**    Department of Dermatology, Henry Ford Hospital, Detroit, Michigan, U.S.A.

**Doris Maria Hexsel**    Department of Dermatology, Pontificia Universidade Catolica do Rio Grande do Sul, and Brazilian Center for Studies in Dermatology, Porto Alegre, Brazil

**Xiaoying Hui**    Department of Dermatology, University of California San Francisco, School of Medicine, San Francisco, California, U.S.A.

**Philippe Humbert**    Department of Dermatology, University Hospital Saint-Jacques, Besançon, France

**Jeanne Duus Johansen**    National Allergy Research Centre, Department of Dermato-Allergology, Gentofte Hospital, University of Copenhagen, Hellerup, Denmark

**Jeanette M. Kamell**    Department of Dermatology, University of California San Francisco, School of Medicine, San Francisco, California, U.S.A.

**Yuji Katsuta**    Shiseido Research Center, Yokohama, Japan

**Ravneet R. Kaur**    University of California Los Angeles, School of Medicine, Los Angeles, California, U.S.A.

**Arnold W. Klein**    Division of Dermatology, David Geffen School of Medicine, University of California at Los Angeles and Cedars-Sinai Medical Center, Los Angeles, California, U.S.A.

**Joshua E. Lane**    Surgery and Internal Medicine, Mercer University School of Medicine, Macon; Section of Dermatology, Medical College of Georgia, Augusta; and Department of Dermatology, Emory University School of Medicine, Atlanta, Georgia, U.S.A.

**Tanda N. Lane**    Department of Dermatology, Emory University School of Medicine, Atlanta, Georgia, U.S.A.

**Cheryl Levin**    San Diego, California, U.S.A.

**Stanley B. Levy**    Revlon Research Center, Edison, New Jersey and Chapel Hill Dermatology, Chapel Hill, North Carolina, U.S.A.

**Henry W. Lim**    Department of Dermatology, Henry Ford Hospital, Detroit, Michigan, U.S.A.

**Jue-Chen Liu**    Johnson & Johnson Consumer Personal Group, Stillman, New Jersey, U.S.A.

**Howard I. Maibach**    Department of Dermatology, University of California San Francisco, School of Medicine, San Francisco, California, U.S.A.

**David J. Moore**    International Speciality Products, Wayne, New Jersey, U.S.A.

**Birgit A. Neudecker**    Department of Dermatology, University of California San Francisco, School of Medicine, San Francisco, California, U.S.A.

**Laurence Nicod** Cellular Biology and Genetic Laboratory, University Hospital Saint-Jacques, Besançon, France

**John E. Oblong** The Procter & Gamble Company, Cincinnati, Ohio, U.S.A.

**Thierry Oddos** Department of Pharmacology, Johnson & Johnson Group of Companies, Val de Reuil, France

**Marianne Nelson O'Donoghue** Department of Dermatology, Rush University Medical Center, Chicago, Illinois, U.S.A.

**Jean-Paul Ortonne** Department of Dermatology, University Hospital of Nice, France

**Grazia Primavera** San Gallicano Dermatological Institute, Rome, Italy

**Nina Otberg** Skin and Laser Center Potsdam, Hair Clinic, Potsdam and Hair Transplant Center Berlin—Potsdam, Berlin, Germany

**Thierry Passeron** Department of Dermatology & INSERM U895 Team 1, University Hospital of Nice, France

**Annick Pons-Guiraud** Paris, France

**John L. Ratz** Tifton, Georgia, U.S.A.

**Anthony V. Rawlings** AVR Consulting Ltd., Cheshire, U.K.

**Victoria L. Rayner Alatorre** Aesthetic Advocates for America, Orlando, Florida, U.S.A.

**Jeanette A. Richards** P&G Beauty and Grooming, Cincinnati, Ohio, U.S.A.

**Mathias Rohr** Institut Dr. Schrader Hautphysiologie, Holzminden, Germany

**Jacques Savary** Galderma International, La Défense, Paris, France

**Douglas Schoon** Science and Technology, Creative Nail Design Inc., Vista, California, U.S.A.

**Andreas Schrader** Institut Dr. Schrader, Hautphysiologie, Holzminden, Germany

**James R. Schwartz** P&G Beauty and Grooming, Cincinnati, Ohio, U.S.A.

**Miri Seiberg** Johnson & Johnson Consumer Personal Group, Skillman, New Jersey, U.S.A.

**F. Anthony Simion** Kao Brands Co., Cincinnati, Ohio, U.S.A.

**Rodney D. Sinclair** Department of Dermatology, University of Melbourne and St. Vincent's Hospital, Melbourne, Victoria, Australia

**Raja K. Sivamani** Department of Dermatology, University of California Davis, School of Medicine, Davis, California, U.S.A.

**Robert Stern** Pathology, Division of Basic Medical Sciences, Touro College of Osteopathic Medicine, New York, New York, U.S.A.

**David C. Story** Kao Brands Co., Cincinnati, Ohio, U.S.A.

**Ying Sun** Johnson & Johnson Consumer Personal Group, Skillman, New Jersey, U.S.A.

**Lily Talakoub** Center for Dermatology and Dermatologic Surgery, Washington, D.C., U.S.A.

**Jen Thiele**     Dermatology Specialists, Inc., Oceanside, California, U.S.A.

**Jeni Thomas**     P&G Beauty and Grooming, Cincinnati, Ohio, U.S.A.

**Emily P. Tierney**     Laser and Skin Surgery Center of Indiana, St. Vincent's Hospital, Carmel, Indiana, U.S.A.

**Ralph M. Trüeb**     Center for Dermatology and Hair Diseases, Zurich, Switzerland

**Céline Try**     Department of Dermatology, University Hospital Saint-Jacques, Besançon, France

**Ethel Tur**     Department of Dermatology, Tel Aviv University Sackler School of Medicine, Tel Aviv, Israel

**Eugene J. Van Scott**     Abington, Pennsylvania, U.S.A.

**Poorna Weerasinghe**     Department of Dermatology, University of Melbourne, Melbourne, Victoria, Australia

**Margaret A. Weiss**     Department of Dermatology, Johns Hopkins University School of Medicine, Baltimore, and Laser Skin and Vein Institute, Hunt Valley, Maryland, U.S.A.

**Robert A. Weiss**     Department of Dermatology, Johns Hopkins University School of Medicine, Baltimore, and Laser Skin and Vein Institute, Hunt Valley, Maryland, U.S.A.

**Naissan O. Wesley**     Skin Care and Laser Physicians of Beverly Hills, Los Angeles, California, U.S.A.

**Ronald C. Wester**     Department of Dermatology, University of California San Francisco, School of Medicine, San Francisco, California, U.S.A.

**Jeff Wu**     Johnson & Johnson Consumer Personal Group, Stillman, New Jersey, U.S.A.

**R. Scott Youngquist**     P&G Beauty and Grooming, Cincinnati, Ohio, U.S.A.

**Ruey J. Yu**     Chalfont, Pennsylvania, U.S.A.

**Hongbo Zhai**     Department of Dermatology, University of California San Francisco, School of Medicine, San Francisco, California, U.S.A.

# Skin physiology and gender

Ethel Tur

## INTRODUCTION

Many characteristics of the body are reflected in the skin, gender being a prominent one. Genetic and hormonal differences affect skin structure and function, resulting in variations between women and men and causing these gender variations to change with age. In addition, exogenous factors differ according to differences in lifestyle between the sexes.

During the last few decades, methodologies used in dermatological research have improved substantially, providing means of objective evaluation of skin function and characteristics. The number of studies addressing various aspects of differences between women and men has increased in the past few years along with the growing interest in studying gender-related differences of physiological and disease processes (1). However, the subject has not yet been systematically studied, so much of the data are by-products of studies with a different focus. This chapter outlines the various aspects of physiological differences between the skin of women and men, on the basis of the available data.

## STRUCTURAL AND ANATOMICAL CHARACTERISTICS (TABLE 1.1)

The skin of female frogs is thicker than that of males in all body regions (2) [whereas the opposite is true for rat skin (3)]. In humans, skin thickness (epidermis and dermis) is greater in men than in women (4), up to 1.428 times (5), whereas the subcutaneous fat thickness is greater in women (6). The skin of men is thicker across the entire age range of 5 to 90 years (7). Hormonal influence on skin thickness was demonstrated when conjugated estrogens were given to postmenopausal women (8). Following 12 months therapy, the dermis was significantly thicker, and histological improvement in the previously atrophic epidermis was noted. Epidermal thickness alone, as measured by optical coherence tomography, does not differ between men and women, except for the forehead epidermis that is thinner in women (9).

Skin collagen and collagen density were measured in addition to dermal thickness (10). The skin of men demonstrated a gradual thinning with advancing age (12–93 years), whereas the thickness of women's skin remained constant up until the fifth decade, after which it decreased with age. The male forearm skin contained more collagen at all ages in the range 15 to 93 years. In both sexes there was a linear decrease in skin collagen with age. Collagen density calculated as the ratio of skin collagen to thickness was lower in women at all ages. The rate of collagen loss was similar in both sexes. Women start with lower collagen content; therefore, they seem to age earlier than men. Collagen density, representing the packing of fibrils in the dermis, is lower in women than in men. This may be due

to androgen, since skin collagen density is increased in patients with virilism.

Forearm skinfold thickness, as measured by a caliper, decreases starting at age 35 for women and 45 for men. Starting at age 35, it is thinner in women than in men (11). In younger subjects: 17 to 24 years, forearm, thigh, and calf skinfold thickness in women is lower than in men (12).

Heel pad thickness, an indicator of soft tissue thickness in the body, was greater in Ethiopian men than in women (13). Skinfold compressibility in Japanese students was greater in women than in men at the pectoral site, and smaller at nuchal, submental, biceps, thigh, suprapatellar, and medial calf sites (6). The changes in the distribution of fat between the ages of 6 to 18 years were studied in 2300 subjects (14). Up to 12 years of age, there was no difference between the two sexes: the mass of the subcutaneous fat increased more than threefold, while that of the internal mass increased less than twice. After the age of 12, the relative mass of the subcutaneous fat continued to increase in girls but not in boys.

The distribution of fat over the body is different in men and women (15). In men, an increase in fat tends to accumulate in the abdominal region and upper parts of the body, whereas in women it is located in the lower body, particularly in the gluteal and femoral regions. In addition, the proportion of body fat is higher in nonobese women than in nonobese men. The characteristic difference in body fat distribution between the sexes exists both in nonobese subjects and obese ones. Lipoprotein lipase activity and mRNA levels were higher in women in both the gluteal and the abdominal regions. In women, higher enzyme activity was found in the gluteus than in the abdomen, whereas in men it was higher in the abdomen. These regional and sex differences in lipoprotein lipase activity might underlie the difference in fat distribution and total fat content. Variation is both at the mRNA level and posttranslational level.

## BIOCHEMICAL COMPOSITION (TABLE 1.2)

Significant age-related differences in the stratum corneum sphingolipid composition were found in women, but not in men (16). From prepubertal age to adulthood there was a significant increase in ceramide 1 and 2 accompanied by a decrease in ceramide 3 and 6. After maturity there was a decrease in ceramide 2 and an increase in ceramide 3. These findings indicate an influence of female hormones on the composition of stratum corneum sphingolipids. These lipids play an important role in the water permeability barrier function of the human epidermis, and thus endocrinological factors may influence this barrier.



Table 1.1 Structural and Anatomical Characteristics

Reference	Finding	Obtained by	Subjects	Conclusions
<b>(A) Significant differences</b>				
9	Forehead epidermis thinner in women Other sites: epidermal thickness does not differ between men and women	Optical coherence tomography	83 Caucasians; Young: 20–40 yr Old: 60–80 yr	
4	Skin thickness in humans greater in men than in women, except for lower back in young subjects	Echographic evaluation	24 women, 24 men; half 27–31 yr, half 60–90 yr	
7	Men's skin thicker than women's across the entire age range of 5–90 yr	Ultrasonic echography; forearm	69 women, 54 men; 5–90 yr	
5	Men's skin thicker than women's, up to 1.438 times	12.0 MHz in B-mode	112 healthy: 43 women, 69 men; 19–28 yr 24 sites	
8	Thickening of dermis following 12 months estrogen therapy	Conjugated estrogen therapy; ultrasound measurement	28 estrogen; 26 placebo; women: 51–71 yr	Estrogens affect skin thickness
10	Men: gradual thinning of skin with advancing age. Women: thickness constant up to 5th decade, then decreasing with age	Skin collagen, skin thickness and collagen density, measured chemically and histologically	Collagen: 80 women, 79 men; 15–93 yr Thickness: 107 women, 90 men; 12–93 yr Density: 26 women, 27 men; 15–93 yr	Rate of collagen loss same in men and women, although total skin collagen content is less in women than men at all ages
11	Forearm skinfold thickness decreases starting at age 35 for women and 45 for men. Starting at age 35 it is thinner in women than in men	Caliper; forearm	145 women and men; 8–89 yr	
12	Skinfold thickness lower in women	Caliper; forearm, thigh, and calf	42 women, 37 men; 17–24 yr	
6	Subcutaneous fat thickness greater in women	Caliper and ultrasound	45 women, 41 men; Japanese; 18–22 yr	
13	Heel pad thickness greater in men than in women; correlation with body weight	Ankle X ray	113 women, 125 men; Ethiopian; 10–70 yr	
6	Skinfold compression in women is greater in the trunk and lower in the limbs	Caliper and ultrasound	45 women, 41 men; Japanese; 18–22 yr	
14	Up to 12 yr of age no difference between the sexes. Subcutaneous fat increases more than threefold, while internal fat mass increases less than twice. After 12 yr, the relative mass of the subcutaneous fat increased in girls but not in boys	Caliper	1292 women, 1008 men; ages 6, 8, 10, 18 yr	
15	Lipoprotein lipase activity higher in women. Women: higher values in gluteus than abdomen. Men: higher in abdomen	Lipoprotein lipase activity and mRNA levels measured; hybridization, Northernblot	8 women, 11 men; 37 ± 4 yr	Regional and sex differences in lipoprotein lipase activity might underlie the difference in fat distribution and total fat content. Variation is both at mRNA and posttranslational levels.
<b>(B) No significant differences</b>				
14	Up to 12 yr: the mass of the subcutaneous fat increases more than threefold, while that of the internal mass increases less than twice in both sexes	Caliper	1292 women, 1008 men; ages 6, 8, 10, 18 yr	

**Table 1.2** Biochemical Composition

Reference	Finding	Obtained by	Subjects	Conclusions
<b>Significant differences</b>				
16	Stratum corneum sphingolipid composition differs with age in women but not in men	Ethanol extracts; biochemical methods of lipid identification	27 women, 26 men; 10–79 yr	Female hormones influence the composition of stratum corneum sphingolipids
18	Women: higher concentrations of metals in hair. Concentrations of copper did not differ with age in men, whereas in women they increased with age	Liquid chromatography; trace metal determination	60 women, 72 men; 6–40 yr	

Human tissue kallikreins are a family of 15 trypsin or chymotrypsin-like secreted serine proteases (hK1–hK15). hK5, hK6, hK7, hK8, and hK13 have been identified in the stratum corneum, stratum granulosum, and skin appendages. hK6 and hK14 were significantly lower in women between 20 and 59 years (17).

Differences in the metal content of human hair were found between men and women: higher concentrations of metals were noted in women. Concentrations of copper did not differ with age in men, whereas an increase in concentration with increased age was noted in women (18).

### MECHANICAL PROPERTIES (TABLE 1.3)

Clinical assessment, as well as objective measurements of stratum corneum hydration, and grading of scaling (by adhesive tape strippings followed by densitometry readings) showed no differences between men and women (19). A positive effect of estrogens on stratum corneum hydration and wrinkles was demonstrated when estriol or estradiol cream was applied on the face of perimenopausal women (20).

Epidermal hydration affects the friction between the skin and textiles. Friction of women showed higher moisture sensitivity than men, when measured at different hydration states, when forearm skin was rubbed with dry to completely wet textile. Higher skin hydration caused gender-specific changes in its mechanical properties and surface properties, leading to softening and increased contact area (21).

Other studies showed no difference of frictional properties of the skin, as well as stratum corneum hydration, between men and women, in both young and old subjects (22–24). In addition, transepidermal water loss showed no difference between the two sexes. In contrast, another study (25) found lower basal transepidermal water loss values in women compared with men aged 18 to 39 years.

The adhesion of the stratum corneum, measured in vitro in skin biopsy samples, did not differ between men and women in several body regions (26). But age (and probably hormonal) related differences were demonstrated in vivo by measuring the speed of dermal-epidermal separation utilizing the time required for blisters to form by controlled suction (27). From 15 up to 69 years of age, women exhibited longer blistering times than men in both antecubital and abdominal sites. The difference was more pronounced in the age range 15 to 39 years than 40 to 69 years, and disappeared in older ages.

Skin elasticity did not differ between the sexes, as measured utilizing two suction cup methods (21,28). Similarly, torsional extensibility of the skin, as measured by a twistometer, did not differ between the sexes (7).

Cutaneous extensibility was identical in men and women, but after hydration it increased only in women (29). Hydration changes the properties of the stratum corneum, softening it, and thus allowing the difference in dermal thickness to express itself as a difference in extensibility. Since the dermis is thinner in women, elimination of the stratum corneum factor allows a rapid extensibility of the skin in women.

Plasticity was found to be greatedened in women than in men in three sites of the foot in one study (30).

### FUNCTIONAL DIFFERENCES (TABLE 1.4)

Following pilocarpine iontophoresis, sweat secretion rates were higher in men than in women in both healthy and chronic renal failure subjects (23).

Body sweat distribution over the upper body in nine clothed male and female runners of equal fitness while running at 65% and subsequent 15-minute rest in a moderate climate (25°C, 53% RH) was investigated using technical absorbent materials to collect the sweat produced. Local sweat rates were higher in men for the mid-front, sides, and mid lateral back compared with women. Both sexes showed similar sweat distribution patterns over the upper body with some exceptions. Men showed higher relative (local to overall) sweat rates than women for the mid lateral back, while it was lower for the upper arm, lateral lower back, and upper central back. Sweating in both sexes was highest along the spine, and higher on the back as a whole than the chest as a whole. Upper arm sweat rate was lowest. Men showed a higher ratio of highest to lowest local sweat rates (31).

The fatty acid composition of sebum is affected by androgens in both sexes (32).

Sex-related differences in the metabolism in the skin of topically applied compounds were found in guinea pig skin (33).

### DIFFERENCES IN RESPONSE TO IRRITANTS (TABLE 1.5)

The incidence of irritant dermatitis is higher in women than in men, but experimental irritant dermatitis does not differ between men and women (34,35). Occupational factors leading to a greater exposure to irritants by women may provide an explanation of this discrepancy. In a study of skin irritability by sodium lauryl sulfate, women showed lower baseline transepidermal water loss compared with men, but after irritation both sexes gave similar transepidermal water loss values (25). The importance of interpretation of the results, and the lack of a standardized way of analyzing them, is illustrated in the latter

**Table 1.3** Mechanical Properties

Reference	Finding	Obtained by	Subjects	Conclusions
<b>(A) Significant differences</b>				
27	From 15 to 69 yr of age women exhibited longer blistering times than men. The difference was more pronounced in the age range 15–39 yr than in 40–69 yr, and disappeared in older ages	Measuring the speed of dermal-epidermal separation utilizing the time required for blisters to form by controlled suction; antecubital and abdominal sites	178 women, 15–101 yr; 209 men, 16–96 yr	
21	Friction of women showed higher moisture sensitivity than men	Corneometry; forearm skin; rubbing with various hydration states, dry to wet textile	11 women, 11 men	Higher skin hydration causes gender-specific changes in its mechanical properties, leading to softening and increased contact area
<b>(B) No significant differences</b>				
19	Stratum corneum hydration, and grading of scaling showed no differences between men and women	Clinical assessment and bioengineering measurement	50 women, 22 men; 21–61 yr	
20	A positive effect of estrogens on facial skin: moisture increased, wrinkles decreased	Stratum corneum hydration and wrinkles—profilometry of skin replicas	18 women (8 applied estriol, 10 estradiol); 46–66 yr	Topical treatment with estrogen seems promising
22	No difference between men and women in friction, moisture, transepidermal water loss	Bioengineering measurement	7 women, 25 yr (mean); 7 men, 29 yr; 7 women, 75 yr; 8 men, 74 yr	
23	No difference in moisture	Bioengineering; healthy and chronic renal failure subjects	Healthy: 24 women, 21 men. Patients: 30 women, 50 men	
28	Skin elasticity did not differ between the sexes, as measured by suction devices	In vivo suction device (bioengineering)	Young: 8 women (26 yr); 8 men (28 yr); Old: 9 women (75 yr); 8 men (75 yr)	
21	Skin viscoelasticity comparable for women and men	Suction chamber; forearm skin; rubbing with various hydration states, dry to wet textile	11 women, 11 men	
7	Torsional extensibility did not differ between men and women	Twistometer	69 women, 54 men; 5–90 yr	
26	The adhesion of the stratum corneum did not differ between men and women	Biopsy; in vitro measurement of the force needed to separate cells	9–34 women and men (number varied with site studied); 20–40 yr	

**Table 1.4** Functional Differences

Reference	Finding	Obtained by	Subjects	Conclusions
<b>Significant differences</b>				
23	Men sweat more than women	Pilocarpine iontophoresis—healthy and chronic renal failure subjects	Healthy: 24 women, 21 men. CRF patients: 30 women, 50 men; 18–75 yr	
31	Local sweat rates higher in men for the mid-front, sides, and mid lateral back. Men showed higher relative (local to overall) sweat rates than women for the mid lateral back, while it was lower for the upper arm, lateral lower back, and upper central back.	Technical absorbent materials to collect the sweat produced in a moderate climate (25°C, 53% RH)	9 Clothed male and female runners while running at 65% and subsequent 15-min rest	
29	Cutaneous extensibility increased only in women after hydration	Bioengineering methods	15 women, 14 men; 23–49 yr and 60–93 yr	Hydration allows the effect of thinner dermis in women to be reflected in extensibility

Abbreviation: CRF, chronic renal failure.

**Table 1.5** Irritants

Reference	Finding	Obtained by	Subjects	Conclusions
<b>(A) Significant differences</b>				
34	Incidence of irritant dermatitis higher in women than in men			Occupational factors
25	Lower baseline transepidermal water loss in women compared with men, but after irritation similar values in both sexes	Sodium lauryl sulfate irritation; evaporimeter	15 women, 23 men; 18–39 yr	Comparing the irritation index (the difference between irritated and unirritated values over unirritated): female skin more irritable
37	Higher on the day of minimal estrogen/progesterone secretion compared with the day of maximal secretion. Also higher on the day of maximal progesterone secretion compared with the day of maximal estrogen secretion	Back and forearm sites; baseline transepidermal water loss; evaporimeter	9 Women; 19–46 yr (mean 32 yr)	Barrier function is less complete just prior to the onset of menses compared with the days just prior to ovulation
<b>(B) No significant differences</b>				
35	No significant differences between men and women with or without hand eczema	Irritation tested for 11 irritants at several concentrations	21 women; 21 men with hand eczema; 21 women; 21 men without hand eczema; 20–60 yr	No tendency to stronger reactions in either sex. Speculation: women's occupations lead to a greater exposure to irritants
36	No significant differences between men and women in developing cumulative irritant dermatitis	Repeated once-daily application of 3 concentrations of irritant (SLS), 5 days, followed by a patch test; upper back; bioengineering measurements	7 women, 7 men; 16–65 yr	No sex-related susceptibility to develop cumulative irritant dermatitis. Speculation: women's occupational and domestic duties lead to a greater exposure to irritants

*Abbreviation:* SLS, sodium lauryl sulfate.

study. The authors define an irritation index as the ratio of the difference between the values for irritated and nonirritated skin to the value for nonirritated skin. Although the value for irritated skin did not differ between men and women, this index was higher in women, since the value for nonirritated skin was lower in men, and so the authors conclude that women's skin is more irritable. A review article considering the absolute values following irritation interpreted the same results as indicating no sex-related differences in sodium lauryl sulfate irritation (34). Until a universal way of interpreting the results is established, contradictory conclusions may be reached by different analyses of the same set of data. In another study, baseline transepidermal water loss did not differ between men and women (36). This study found no significant differences between men and women in developing cumulative irritant dermatitis, when visual scoring, transepidermal water loss, skin blood flow, and dielectric water content were assessed. Changes during the menstrual cycle, however, were demonstrated by measuring baseline transepidermal water loss (37).

### CUTANEOUS MICROVASCULATURE (TABLE 1.6)

Hormonal factors affect the skin blood flow: differences between men and women were found during the reproductive years, and differences were found within different phases of the menstrual cycle (38). Moreover, vasospastic diseases, such as Raynaud's phenomenon, are more common in women, more prevalent in

the reproductive years, and improve during pregnancy, suggesting an influence of female sex hormones (39). Skin circulation varied during the menstrual cycle. There might be a direct influence of sex hormones on the blood vessel wall, or an indirect systemic hormonal action causing a cyclic pattern in women. Estrogens influence the sympathetic nervous system, inducing an upregulation of (vasoconstrictive)  $\alpha_2$ -adrenoceptors. Thus, blood flow measurements utilizing laser Doppler flowmetry revealed a reduction of basal cutaneous blood flow in women compared with men (39–41), but these differences existed only in young women and not in women over 50 years (42). This reduction was due to a basal increase in sympathetic tone rather than to a local structural or functional difference in the cutaneous circulation.

The vasodilatation induced by local heating occurred at a lower skin temperature in women (43). However, the maximum skin blood flow following heating of the skin was not different between men and women, and neither was the post-occlusive reactive hyperemia response in a study including a group of women aged 20 to 59 years (39). In contrast, in a study that divided women according to age, the reactive hyperemia response was lower in young women compared both with women over 50 years and with young men (42). The latter study also measured the response to cooling, which was prolonged in young women compared with the other two groups.

Skin microvascular response to vasodilators was evaluated by laser Doppler perfusion imager, and instrument that

Table 1.6 Cutaneous Microcirculation

Reference	Finding	Obtained by	Subjects	Conclusions
<b>(A1) Significant differences</b>				
39	Reduction in basal skin blood flow in women	Bioengineering measurement	56 women, 44 men; 20–59 yr	
41	Reduction in facial basal skin blood flow in women	Laser Doppler	5 women, 5 men; 25–52 yr	
40	Reduction in basal skin blood flow in women	Bioengineering measurement; cooling and warming to change sympathetic tone	26 women, 23 men; 23–38 yr	Sympathetic tone is increased, not a structural or functional difference in the cutaneous circulation
38	Skin circulation varied during menstrual cycle: basal flow lowest in the luteal phase, highest in the preovulatory phase. Greatest cold-induced constriction and lowest recovery in the luteal phase	Bioengineering measurements at 4 times during the menstrual cycle	31 women; 15–45 yr	Skin blood flow and its response to cold varies during the menstrual cycle
42	Reactive hyperemia response lower in young women as compared with both women over 50 yr or young men. The response to cooling prolonged in young women compared with the other two groups	Bioengineering measurement; postocclusive reactive hyperemia and direct and indirect cooling	12 women, 19–39 yr; 13 women, 51–67 yr; 13 men, 22–47 yr	Hormonal factors might explain the differences. Different dressing habits may also contribute
43	Vasodilatation induced by local heating occurs at a lower skin temperature in women	Bioengineering measurement	9 women, 6 men; age not specified	
44	Response to nitroprusside higher in women before menopause than after	Laser Doppler perfusion imager, iontophoresis	21 women, 13 men; 18–80 yr	Indicating functional and structural changes in skin—vasculature of women with aging
3	Histamine produced bigger wheals in women	Histamine administered by iontophoresis	33 women, 38 men; 15–52 yr	Differences in the stratum corneum layer
49	Endothelin-B receptors mediate vasoconstriction in men and vasodilatation in women	Laser Doppler, microdialysis	11 women, 11 men; 33 ± 3 women, 30 ± 3 men	Resting tone is different in women and men
<b>(A2) Significant differences: transcutaneous oxygen pressure</b>				
46	Significantly higher values of transcutaneous oxygen pressure in women	Bioengineering; anterior chest, forearm	18 women, 42 men; 22–88 yr	
47	Significantly higher values of transcutaneous oxygen pressure in women	Bioengineering; 23 sites on face, extremities, and trunk	7 women, 12 men; 21–63 yr	Might be explained by women's thinner epidermis
48	Transcutaneous oxygen pressure during postocclusive reactive hyperemia greater in adult women than in men, but did not differ between boys and girls	Bioengineering measurement, forearm, postocclusive reactive hyperemia, 35–37°C	Adults: 30 women, 37 men; 22–60 yr. Children before puberty: 34	Hormonal influence is indicated
<b>(B) No significant differences</b>				
45	No difference in cutaneous blood flow response to histamine	Topical and intradermal administration; bioengineering methods	10 women, 10 men; 24–34 yr	
39	No difference in postocclusive reactive hyperemia and maximum skin blood flow following heating	Bioengineering methods	56 women, 44 men; 20–59 yr	

maps the skin blood perfusion. The substances used were acetylcholine (an endothelium-dependent vasodilator) and nitroprusside and isoprenaline (two endothelium-independent vasodilators with different modes of action). The substances

were iontophORIZED into the skin. The response to nitroprusside, and to a lesser extent to acetylcholine, was higher in women before menopause than after (44), reflecting functional and structural changes in skin vasculature with aging.

The cutaneous blood flow response to topical and intra-dermal administration of histamine was comparable in men and women at three anatomical sites: the back, volar side of the forearm, and ankle (45). These observations indicate that there are no functional differences between men and women in the skin microvascular response to histamine. However, histamine administered by iontophoresis produced bigger wheals in women, as measured by laser Doppler flowmetry (33). The bigger wheals were attributed to differences in the stratum corneum layer, which is the main obstacle to penetration.

*Transcutaneous oxygen pressure* is a method that measures changes in oxygen pressure at the skin surface that are mainly determined by changes in skin blood flow. During skin surface measurement, significantly higher values of transcutaneous oxygen pressure were noted in women (46,47). The difference might be explained by the thinner epidermis of women. Age-related sex differences were noted in measuring transcutaneous oxygen pressure during postocclusive reactive hyperemia. Greater values were found in adult women than in men, but no differences between boys and girls (48).

The contribution of endothelin-B receptors to resting cutaneous vascular tone differs between men and women. In men, endothelin-B receptors mediate vasoconstriction, whereas in women, endothelin-B receptors mediate vasodilation. Blockade of endothelin-B receptors by a competitive antagonist (BQ-788) in men caused skin vasodilation consistent with removal of a tonic vasoconstrictor effect of endothelin-B. In women, it caused a vasoconstriction, demonstrating release of tonic vasodilator activity (49).

## SENSORY FUNCTIONS (TABLE 1.7) Thermoregulatory Response

Studies of human thermoregulation were conducted by exposing subjects to various thermal environments. The importance of taking into account all the possible variables is demonstrated in studies of the physiological responses to heat stress (50): data showed differences between women and men. But when taking into consideration the differences in the percentage of fat in the body and the ratio between the body surface and mass, the effect of gender disappeared.

In contrast to these results of heat stress, the response to cold stress of Japanese young subjects differed with gender, although ratios of body surface area to mass were similar (51). Subjects were exposed to cold (12°C) for one hour at rest in summer and in winter. In winter, tolerance to cold in women was higher than that in men, whereas no significant differences between the sexes were found in summer. The differences in cold tolerance may be caused by differences in the distribution of fat over the body, although ratios of body surface area to mass were similar in the two sexes.

The thermal sensitivity distribution (topographical mapping) over the glabrous skin of the hand in men and in women was assessed by measuring warm and cold thresholds in 25 healthy volunteers (12 women, 13 men), applying a multisite test of 23 locations on the volar part of the hand. The palm area was more sensitive than the fingers to both warm and cold stimuli. On the palm itself, the proximal part was the most sensitive. Women were more sensitive than men to both warm and cold sensations (52).

Cold-induced vasomotor response was measured by laser Doppler flowmetry in 12 healthy men and 12 healthy women. Both direct response (at the site of cooling) and indirect response

(at a site remote from the cooling site) were measured (53). The women were tested twice, once in the follicular and once in the luteal phase of the menstrual cycle. Blood flow was measured before and during local cooling of one hand at 15°C. Local cooling evoked a significantly greater decrease in cutaneous blood flow in women than in men in direct as well as in indirect response conditions. Direct response to local cooling was significantly greater in the luteal phase than in the follicular phase. In contrast, there was no menstrual-cycle-dependent difference in the indirect response to cold. Thus, sympathetic neural reactivity, as assessed by way of an indirect response to a cold stimulus, significantly contributes to gender differences in the response to local cooling. In contrast, the variation in microvascular responsiveness to cold exposure due to the menstrual cycle is most probably caused by local vascular mechanisms rather than by variation in sympathetic neural reactivity to local cooling.

Sex-related differences in thermoregulatory responses while wearing protective clothing were found (54). Women were at a thermoregulatory disadvantage compared with men when wearing protective clothing and exercising in a hot environment. This disadvantage can be attributed to the lower specific heat of adipose versus nonadipose tissue and higher percentage of body fatness.

## Thermal Response to Stimulation

The decrease in finger temperature as a response to musical stimulus was greater in women (55). This may be due to differences between men and women in vascular autonomic sensitivity to music, or to differences in sensitivity or density of peripheral vascular adrenergic receptors.

### *Electrodermal Responses*

Electrodermal asymmetry has been considered as an index of hemispheric specialization. A study recorded the magnitude and frequency of the skin conductance responses when subjects listened to tones (56). Subjects were right-handed to control the effects of handedness. Men displayed more asymmetry between hands, with larger skin conductance responses on the left hand. In women, asymmetry was less marked, and larger skin conductance responses were found on the right hand. These results indicate a possible hemispheric difference in response to auditory stimuli.

## Thermal and Pain Sensation, Pressure Sensitivity

Sensation in the skin can be studied in relation to pain. Pain can be induced by mechanical, electrical, chemical, or thermal stimulus. Pain sensation is best determined by the threshold at which pain begins, and the stimulus required to produce it can be quantified. Thermal and pain sensations are mediated by cutaneous receptors and travel through myelinated (A $\delta$ ) and unmyelinated (C) nerve fibers. Women were more sensitive to small temperature changes and to pain caused by either heat or cold (57). Another study measured the threshold of the pricking sensation provoked by heat projected to the skin from a lamp (58). The pricking pain threshold increased with age in both sexes. In addition, the threshold of women was lower at all ages in the range 18 to 90 years. Possible explanations to the difference between the sexes are as follows:

1. Anatomical differences in skin thickness
2. Differences in blood flow and blood vessels that absorb part of the heat transmitted to the skin
3. Differences in nervous structure or function

**Table 1.7** Sensory Function

Reference	Finding	Obtained by	Subjects	Conclusions
<b>(A) Significant differences</b>				
57	Women more sensitive to small temperature changes and to pain caused by either heat or cold	Marstock method—quantitative	67 women, 83 men; 10–73 yr	
58	Lower threshold values in women than in men	Pricking pain sensation to heat; threshold determination, volar forearm	93 women, 165 men, 18–28 yr; 132 women, 135 men, 50–90yr	
59	Women more sensitive than men: palm and sole, but not on the forearm	Pressure threshold measurement; palm, sole, forearm	68 women, 68 men; 17–30 yr	
60	Neonate girls: significantly higher conductance than boys	Skin conductance (autonomic function)	20 women, 20 men; neonates: 60–110 hr	These differences may represent differences in maturation. Very young: no effect yet of training and different behavior accorded the sexes
51	Women's tolerance to cold superior to men's in winter	Exposed to cold (12°C) for 1 hr at rest in summer and in winter; skin and body temperature	7 women, 8 men; Japanese; 18–26 yr	Differences in fat distribution over the body, although ratios of body surface area to mass were similar in the two sexes, might have contributed to the differences in cold tolerance
55	Greater decrease in women in finger temperature as a response to musical stimulus	Auditory stimulation, music; skin temperature, index finger	60 women, 60 men; young students	Possible explanation: difference in vascular autonomic sensitivity to music
56	Men: more asymmetry between hands, larger skin conductance responses on the left hand. Women: less asymmetry, larger skin conductance responses on right hand	Auditory stimulus. Magnitude and frequency of skin conductance responses	15 women, 15 men; 19–27 yr; right-handed	Possible hemispheric differences in response to auditory stimuli
61	Acute muscle or skin pain: skin blood flow increased in women, whereas in men it decreased	Skin sympathetic nerve activity. Hypertonic saline injected into tibialis anterior muscle or into skin. Skin blood flow measurements	Awake human subjects	
<b>(B) No significant differences</b>				
50	Physiological responses to heat stress differ with gender, but depend on fat content and body surface area	Heat stress; ergometer; oxygen uptake; body and skin temperature; sweat rate	12 women, 12 men; 20–28 yr	Differences between women and men disappeared when differences in the percentage of fat in the body and the ratio between body surface and mass were taken into account

Unlike the forearm lower pricking pain sensation threshold in women, pressure threshold was lower in women than in men on the palm and sole, but not on the forearm (59).

#### *Autonomic Function*

Skin conductance measures one aspect of the autonomic function. Neonate girls manifested a significantly higher conductance than boys (60). These differences may represent differences in maturation.

Both acute muscle and skin pain evoked a measurable sympathetic activity in awake human subjects. Sweat release

was increased to the same level in men and women, but dissimilar changes in skin blood flow were recorded: skin blood flow increased in women whereas it decreased in men (61).

#### **SKIN COLOR (TABLE 1.8)**

An article by Tegner (62) gives several examples of artists depicting their female models as lighter skinned than males. Such differences were indeed found utilizing spectrophotometric measurements, in various ethnic populations. A lighter skin in women was demonstrated in studies from Iran (63),

**Table 1.8** Skin Color

Reference	Finding	Obtained by	Subjects	Conclusions
<b>(A) Significant differences</b>				
18	Women's skin lighter	Spectrophotometry	Review article	Not a simple hormonal effect. Differences in melanin, hemoglobin, and carotene
63	Women's skin lighter	Spectrophotometry	33 women, 68 men; 8–24 yr	Differential tanning; vascularity variations
64	Women's skin lighter	Spectrophotometry; upper inner arm	566 women, 578 men; 1–50 yr	During puberty, males darken, females lighten. Different levels of MSH. Hereditary and environmental factors
67	Forehead: boys darker than girls. Medial upper arm: girls darker than boys during early adolescence, not different from boys during middle adolescence, and during late adolescence girls lighter than boys	Skin color, measured by reflectance of forehead and medial upper arm, in adolescents	105 women, 10–16 yr; 105 men, 12–18 yr	Physiological changes during adolescence may cause these sex differences
65	Women's skin lighter. Both sexes darken with age	Spectrophotometry; inner upper arms, lateral forearms, back of hands	461 women, 346 men; 20–69 yr	Different levels of MSH. Difference in sun exposure (tanning and thickening of skin)
69	In the elderly: skin of men darker and redder compared with women, but not in the young	Colorimetric measurements of forehead (sun-exposed) and forearm (protected)	8 women, 5 men, 65–88 yr; 9 women, 4 men, 18–26 yr	
<b>(B) No significant differences</b>				
70	No difference between men and women in epidermal melanocytes counts	5-mm paraffin embedded sections	38 Skin samples of men and women of different ages. DOPA reagent.	
69	In Caucasian babies: pigmentation same for males and females	Colorimetric measurements of 10 sites	10 women, 10 men; 1–10 mo	

*Abbreviation:* MSH, melanocyte-stimulating hormone.

India (64), and Australia (65). In addition to hormonal influences, differences in melanin, hemoglobin, and carotene might be involved, as well as differences in sun exposure. Skin reflectance spectroscopy was measured in 10 anatomical sites in 20 healthy Caucasian babies (mean age 5 months, range 1 to 10 months). The level of skin pigmentation was the same in all the 10 measured sites and there were no gender differences in pigmentation for any site (66). In general, both sexes darken as age increases (65). But the changes are more intricate (64): from the end of infancy to the onset of puberty there is a progressive skin darkening in both sexes. During adolescence they both lighten, but women lighten more. Simple hormonal effects cannot explain this difference, since both testosterone and estrogen provoke darkening rather than lightening of the skin. These changes might be partly attributed to differences in exposure to sunlight, since UV irradiation increases the number of melanocytes in both exposed and unexposed skin. Another study assessed skin color in adolescents (67). The forehead (sun-exposed) pigmentation of boys was darker than that of girls. But the medial upper arm (less sun exposure) pigmentation varied among the different phases of adolescence: girls were darker than boys during early adolescence, during middle adolescence the pigmentation was similar in the two sexes, and during late adolescence girls were significantly lighter than boys.

The lighter skin color of women was attributed to differences in melanin, hemoglobin (variations in vascularity), and carotene (68). Natural selection might give an explanation of the overall visual effect of lighter skin. In addition, women are more homogenous in color than men, since regional variations in reflectance spectrophotometry were smaller in women than in men (68). Colorimetric measurements revealed a darker and redder skin in elderly men (65–88 years) compared with elderly women, but such differences were not found in young subjects (18–26 years) (69). Another study of 461 women and 346 men aged 20 to 69 years found that both sexes darken with age (65). Yet another study did not find difference between men and women in epidermal melanocytes counts (70).

### HORMONAL INFLUENCE (TABLE 1.9)

Any of the above-mentioned differences between women and men might be related to hormonal effects. Some evidence for hormonal influence on the skin has already been mentioned earlier, like the increase of skin thickness following conjugated estrogens treatment of postmenopausal women (8), or the positive effect of estrogens on stratum corneum hydration and wrinkles of the face of perimenopausal women (20), or the changes during the menstrual cycle demonstrated by measuring



**Table 1.9** Hormonal Influence

Reference	Finding	Obtained by	Subjects	Conclusions
<b>Significant differences</b>				
71	Hormone replacement treatment limited the age-related increase in skin extensibility. Other parameters of skin viscoelasticity were not affected	Computerized suction device measuring skin deformability and viscoelasticity; inner forearm	Women: 43 nonmenopausal (19–50 yr); 25 menopausal not treated (46–76 yr); 46 on hormone replacement therapy since onset of menopause (38–73 yr)	Hormone replacement therapy has a preventive effect on skin slackness
72	Collagen content increased by 48% with hormone replacement therapy compared with nontreated subjects	Hydroxyproline and collagen content; biopsies of right thigh below the greater trochanter	Postmenopausal women (35–62 yr); 29 untreated; 26 estradiol + testosterone	Estrogen, or testosterone, or both prevent the decrease in skin collagen content that occurs with aging
73	Increased proportion of type III collagen in the skin of postmenopausal women receiving hormone replacement therapy	Analysis of collagen types; biopsies of lateral thigh	Postmenopausal women (41–66 yr); 14 untreated, 11 estradiol + testosterone	The clinical improvement in the skin following hormone replacement therapy is due not only to increase in total collagen but also to changes in the ratio of type III to type I

baseline transepidermal water loss (37) and skin blood flow (38). Hormone replacement therapy for menopause had an effect on skin extensibility (71): in untreated women a steep increase in skin extensibility was evidenced during the menopause. Hormone replacement treatment limited this age-related increase in skin extensibility, thus having a preventive effect on skin slackness. Other parameters of skin viscoelasticity were not affected. After menopause, the skin becomes thinner, associated with loss in skin collagen content. Collagen content increased with hormone replacement therapy by 48% compared with nontreated subjects (72). Moreover, the ratio of type III to type I collagen in the skin is reduced with age. Postmenopausal women receiving hormone replacement therapy showed an increased proportion of type III collagen in the skin (73). In the future, further hormonal manipulation might change the skin of both men and women in ways we cannot yet predict.

### PILOSEBACEOUS UNIT (TABLE 1.10)

The sebaceous glands are hormone dependent. The increase in their activity during puberty can be stimulated by the administration of the appropriate hormone. Androgenic steroids, of

either gonadal or adrenal origin, have a direct stimulatory effect on sebaceous gland activity. Most of the hormones [thyroid-stimulating hormone (TSH), adrenocorticotrophic hormone (ACTH), follicle-stimulating hormone (FSH), luteinizing hormone (LH)] act indirectly by stimulating their respective endocrine tissues. In other cases, the hormones [for instance, growth hormone (GH)] act synergistically with another hormone to which the sebaceous gland is sensitive. Average values for sebum secretion were significantly higher in men than in women for age ranges 20 to over 69 years, but not for 15 to 19 years (74). This difference in sebaceous gland activity becomes more apparent in the 50 to 70 years age range, when the secretion in men remains unaltered, whereas in women there is a significant decrease in sebum output, probably a result of decreased ovarian activity.

Beginning in young adulthood there is an age-related decline in wax ester secretion—thus hormones also affect the composition of sebum.

Obviously, the distribution of hair over the body differs between men and women. The hair follicles possess individual mechanisms controlling the evolution and triggering of successive phases, but systemic factors like hormones and external

**Table 1.10** Pilosebaceous Unit

Reference	Finding	Obtained by	Subjects	Conclusions
<b>Significant differences</b>				
75	During January women's hair was denser and the percentage of telogen hair lower compared with men	Phototrichogram; hair count after washing	7 women, 29–49 yr; 7 men, 25–47 yr	
74	Higher sebum secretion in men than in women for age ranges 20 to over 69 yr, but not for the 15–19 yr age range. In the 50–70 yr age range, the secretion in men remains unaltered, whereas in women there is a significant decrease in sebum output, probably as a result of decreased ovarian activity	Sebum production	330 women, 458 men; 15 yr to over 69 yr	
74	No correlation between sebum production and plasma testosterone	Sebum production and plasma androgen levels	8 women, 28 men	

factors also play a significant part. The season of the year has an effect on hair growth and hair shedding. From data given in a study concerning this seasonal effect (75), we calculated sex differences, which were not discussed in the study. The data refer to the month of January. Women's hair was denser and the percentage of telogen hair lower compared with that in men.

The diversity of male and female hair patterns is determined by a difference in the transformation of vellus to terminal hair, stimulated by androgens, but also by racial and genetic factors. In Koreans, women had a significantly higher number of terminal hairs than men (76).

The effect of androgens on hair growth varies according to body site, and may be opposite, like transforming vellus hair on the face to terminal beard hair at puberty and the reverse on the scalp. The face, scalp, beard, axilla, and pubic hair follicles are targets for androgens. Androgen affects different cells in the dermal papilla, which is also affected by melanocyte-stimulating hormone (MSH), prolactin, thyroid hormones, pregnancy, and nutritional state (77). In addition to higher serum levels of testosterone, female facial hirsutism correlated with obesity and age (78).

Despite exposure to the same circulatory hormones, the activity of hair follicles depends on the body site, varying from no effect on the eyelashes to stimulation in many other areas. High levels of testosterone inhibit the hair papilla cells and outer root sheath keratinocytes, and have a lesser effect on fibroblasts and interfollicular keratinocytes, while low levels of testosterone have no effect. The opposite was found with estrogen and cyproterone (79).

The effect of estrogens (17- $\beta$ -estradiol, E2) on estrogen receptor (ER) expression and gene regulation of human scalp hair follicles was studied in vitro. The distribution pattern of ER $\beta$  and TGF- $\beta$ 2 immunoreactivity differed between men and women hair follicles after 48 hours of culture. Of 1300 genes tested, the regulation of several genes differed with sex. Thus, substantial sex-dependent differences were found in the response of frontotemporal human scalp hair follicles to E2 (80).

## CONCLUSIONS

Maintaining skin health is an intricate orchestration of many variables. The need for hard data is paramount, not only for gaining knowledge about the anatomy and biology of human skin but also for the assessment of pathophysiological processes and for clinical management of skin diseases. New and improved instrumentation will allow for more studies, leading to a detailed description of physiological differences between men and women.

We hope that this chapter will trigger further investigations of the subject.

## REFERENCES

1. Dao H Jr., Kazin RA. Gender differences in skin: a review of the literature. *Gen Med* 2007; 4:308-328.
2. Greven H, Zanger K, Schwinger G. Mechanical properties of the skin of *Xenopus laevis* (Anura, Amphibia). *J Morphol* 1995; 224:15-22.
3. Magerl W, Westerman RA, Mohner B, et al. Properties of transdermal histamine iontophoresis: differential effects of season, gender, and body region. *J Invest Dermatol* 1990; 94:347-352.
4. Seidenari S, Pagnoni A, Di Nardo A, et al. Echographic evaluation with image analysis of normal skin: variations according to age and sex. *Skin Pharmacol* 1994; 7:201-209.
5. Krackowizer P, Brenner E. Thickness of the human skin: 24 points of measurement. *Phlebologie* 2008; 37:83-92.
6. Hattori K, Okamoto W. Skinfold compressibility in Japanese university students. *Okajimas Folia Anat Jpn* 1993; 70:69-78.
7. Escoffier C, de Rigal J, Rochefort A, et al. Age-related mechanical properties of human skin: an in vivo study. *J Invest Dermatol* 1989; 93:353-357.
8. Maheux R, Naud F, Rioux M, et al. A randomized, double-blind, placebo-controlled study on the effect of conjugated estrogens on skin thickness. *Am J Obstet Gynecol* 1994; 170:642-649.
9. Gambichler T, Matip R, Moussa G, et al. In vivo data of epidermal thickness evaluated by optical coherence tomography: effects of age, gender, skin type, and anatomic site. *J Dermatol Sci* 2006; 44:145-152.
10. Shuster S, Black MM, McVitie E. The influence of age and sex on skin thickness, skin collagen and density. *Br J Dermatol* 1975; 93:639-643.
11. Leveque JL, Corcuff P, de Rigal J, et al. In vivo studies of the evolution of physical properties of the human skin with age. *Int J Dermatol* 1984; 18:322-329.
12. Davies BN, Greenwood EJ, Jones SR. Gender differences in the relationship of performance in the handgrip and standing long jump tests to lean limb volume in young adults. *Eur J Appl Physiol* 1988; 58:315-320.
13. Tilahun M, Atnafu A. Heel pad thickness of adult Ethiopian patients in Tikur Anbessa hospital, Addis Abeba. *Ethiop Med J* 1994; 32:181-187.
14. Malyarenko TN, Antonyuk SD, Malyarenko Yu E. Changes in the human fat mass at the age of 6-18 years. *Arkh Anat Gistol Embriol* 1988; 94:43-47.
15. Arner P, Lithell H, Wahrenberg H, et al. Expression of lipoprotein lipase in different human subcutaneous adipose tissue regions. *J Lipid Res* 1991; 32:423-429.
16. Denda M, Koyama J, Hori J, et al. Age and sex-dependent change in stratum corneum sphingolipids. *Arch Dermatol Res* 1993; 285:415-417.
17. Komatsu N, Saijoh K, Sidiropoulos M, et al. Quantification of human tissue kallikreins in the stratum corneum: dependence on age and gender. *J Invest Dermatol* 2005; 125:1182-1189.
18. Sturado A, Parvoli G, Doretti L, et al. The influence of color, age and sex on the content of zinc, copper, nickel, manganese, and lead in human hair. *Biol Trace Elem Res* 1994; 40:1-8.
19. Jemec GBE, Serup J. Scaling, dry skin and gender. *Acta Derm Venereol (Stockh)* 1992; 177(suppl):26-28.
20. Schmidt JB, Binder M, Macheiner W, et al. Treatment of skin ageing symptoms in perimenopausal females with estrogen compounds. A pilot study. *Maturitas* 1994; 20:25-30.
21. Gerhardt LC, Strassle V, Lenz A, et al. Influence of epidermal hydration on the friction of human skin against textiles. *J R Soc Interface* 2008; 5:1317-1328.
22. Cua AB, Wilhelm KP, Maibach HI. Frictional properties of human skin: relation to age, sex and anatomical region, stratum corneum hydration and transepidermal water loss. *Br J Dermatol* 1990; 123:473-479.
23. Yosipovitch G, Reis J, Tur E, et al. Sweat secretion, stratum corneum hydration, small nerve function and pruritus in patients with advanced chronic renal failure. *Br J Dermatol* 1995; 133:561-564.
24. Li W, Qu S, Zhou Z. Frictional properties of human skin at different ages, gender and anatomical regions. *J Biomed Eng* 2007; 24:824-828.
25. Goh CL, Chia SE. Skin irritability to sodium lauryl sulphate—as measured by skin water vapor loss—by sex and race. *Clin Exp Dermatol* 1988; 13:16-19.
26. Chernova TA, Melikyants IG, Mordovtsev VN, et al. Mechanical properties of the skin in normal subjects. *Vestn Dermatol Venereol* 1984; 2:12-15.

27. Kiistala U. Dermal-epidermal separation. *Ann Clin Res* 1972; 4:10-22.
28. Pedersen L, Hansen B, Jemec GB. Mechanical properties of the skin: a comparison between two suction cup methods. *Skin Res Technol* 2003; 2:111-115.
29. Auriol F, Vaillant L, Machet L, et al. Effects of short time hydration on skin extensibility. *Acta Derm Venereol (Stockh)* 1993; 73:344-347.
30. Hashmi F, Malone-Lee J. Measurement of skin elasticity on the foot. *Skin Res Technol* 2007; 13:252-258.
31. Havenith G, Fogarty A, Bartlett R, et al. Male and female upper body sweat distribution during running measured with technical absorbents. *Eur J Appl Physiol* 2008; 104:245-255.
32. Yamamoto A, Serizawa S, Ito M, et al. Fatty acid composition of sebum wax esters and urinary androgen level in normal human individuals. *J Dermatol Sci* 1990; 1:269-276.
33. Boehnlein J, Sakr A, Lichtin JL, et al. Characterization of esterase and alcohol dehydrogenase activity in skin. Metabolism of retinyl palmitate to retinol (vitamin A) during percutaneous absorption. *Pharm Res* 1994; 11:1155-1159.
34. Wilhelm KP, Maibach HI. Factors predisposing to cutaneous irritation. *Dermatol Clin* 1990; 8:17-22.
35. Bjornberg A. Skin reactions to primary irritants. *Acta Derm Venereol (Stockh)* 1975; 55:191-194.
36. Lammintausta K, Maibach HI, Wilson D. Irritant reactivity in males and females. *Contact Dermatitis* 1987; 17:276-280.
37. Harvell J, Hussona-Safed I, Maibach HI. Changes in transepidermal water loss and cutaneous blood flow during the menstrual cycle. *Contact Dermatitis* 1992; 27:294-301.
38. Bartelink ML, Wollersheim A, Theeuwes A, et al. Changes in skin blood flow during the menstrual cycle: the influence of the menstrual cycle on the peripheral circulation in healthy female volunteers. *Clin Sci* 1990; 78:527-532.
39. Maurel A, Hamon P, Macquin-Mavier I, et al. Flux microcirculatoire cutané étude par laser-doppler. *Presse Med* 1991; 20:1205-1209.
40. Cooke JP, Creager MA, Osmundson PJ, et al. Sex differences in control of cutaneous blood flow. *Circulation* 1990; 82:1607-1615.
41. Mayrovitz HN, Regan MB. Gender differences in facial skin blood perfusion during basal and heated conditions determined by laser Doppler flowmetry. *Microvasc Res* 1993; 45:211-218.
42. Bollinger A, Schlumpf M. Finger blood flow in healthy subjects of different age and sex and in patients with primary Raynaud's disease. *Acta Chir Scand* 1975; 465(suppl):42-47.
43. Walmsley D, Goodfield MJD. Evidence for an abnormal peripherally mediated vascular response to temperature in Raynaud's phenomenon. *Br J Rheumatol* 1990; 29:181-184.
44. Algotsson A, Nordberg A, Winblad B. Influence of age and gender on skin vessel reactivity to endothelium-dependent and endothelium-independent vasodilators tested with iontophoresis and a laser Doppler perfusion imager. *J Gerontol Med Sci* 1995; 50:121-127.
45. Tur E, Aviram G, Zeltser D, et al. Histamine effect on human cutaneous blood flow: regional variations. *Acta Derm Venereol (Stockh)* 1994; 74:113-116.
46. Glenski JA, Cucchiara RF. Transcutaneous O<sub>2</sub> and CO<sub>2</sub> monitoring of neurosurgical patients: detection of air embolism. *Anesthesiology* 1986; 64:546-550.
47. Orenstein A, Mazkereth R, Tsur H. Mapping of the human body skin with transcutaneous oxygen pressure method. *Ann Plast Surg* 1988; 20:419-425.
48. Ewald U. Evaluation of the transcutaneous oxygen method used at 37°C for measurement of reactive hyperaemia in the skin. *Clin Physiol* 1984; 4:413-423.
49. Kellogg DL Jr., Liu Y, Pergola PE. Gender differences in the endothelin-B receptor contribution to basal cutaneous vascular tone in humans. *J Appl Physiol* 2001; 91:2407-2411.
50. Havenith G, van Middendorp H. The relative influence of physical fitness, acclimatization state, anthropometric measures and gender on individual reactions to heat stress. *Eur J Appl Physiol* 1990; 61:419-427.
51. Sato H, Yamasaki K, Yasukouchi A, et al. Sex differences in human thermoregulatory response to cold. *J Human Ergol* 1988; 17:57-65.
52. Li X, Petrini L, Defrin R, et al. High resolution topographical mapping of warm and cold sensitivities. *Clin Neurophysiol* 2008; 119:2641-2646.
53. Cankar K, Finderle Z, Struel M. Gender differences in cutaneous laser Doppler flow response to local direct and contralateral cooling. *Vasc Res* 2000; 37:183-188.
54. McLellan TM. Sex-related differences in thermoregulatory responses while wearing protective clothing. *Eur J Appl Physiol Occup Physiol* 1998; 78:28-37.
55. McFarland RA, Kadish R. Sex differences in finger temperature response to music. *Int J Psychophysiol* 1991; 11:295-298.
56. Martinez-Selva JM, Roman F, Garcia-Sanchez FA, et al. Sex differences and the asymmetry of specific and non-specific electrodermal responses. *Int J Psychophysiol* 1987; 5:155-160.
57. Meh D, Denislic M. Quantitative assessment of thermal and pain sensitivity. *J Neurol Sci* 1994; 127:164-169.
58. Procacci P, Bozza G, Buzzelli G, et al. The cutaneous pricking pain threshold in old age. *Geront Clin* 1970; 12:213-218.
59. Weinstein S, Sersen E. Tactual sensitivity as a function of handedness and laterality. *J Comp Physiol Psychol* 1961; 54:665-669.
60. Weller G, Bell RQ. Basal skin conductance and neonatal state. *Child Dev* 1965; 36:647-657.
61. Burton AR, Birznieks I, Spaak J, et al. In vivo data of epidermal thickness induced acute pain on skin sympathetic nerve activity in human subjects. *Exp Brain Res* 2009; 195:317-324.
62. Tegner E. Sex differences in skin pigmentation illustrated in art. *Am J Dermatopathol* 1992; 14:283-287.
63. Mehrai H, Sunderland E. Skin colour data from Nowshahr City, Northern Iran. *Ann Hum Biol* 1990; 17:115-120.
64. Banerjee S. Pigmentary fluctuation and hormonal changes. *J Genet Hum* 1984; 32:345-349.
65. Green A, Martin NG. Measurement and perception of skin colour in a skin cancer survey. *Br J Dermatol* 1990; 123:77-84.
66. Lock-Andersen J, Wulf HC, Knudstorp ND. Skin pigmentation in Caucasian babies is high and evenly distributed throughout the body. *Photodermatol Photoimmunol Photomed* 1998; 14:74-76.
67. Kalla AK, Tiwari SC. Sex differences in skin color in man. *Acta Genet Med Gemellol* 1970; 19:472-476.
68. Frost P. Human skin color: a possible relationship between its sexual dimorphism and its social perception. *Perspect Biol Med* 1988; 32:38-58.
69. Kelly RI, Pearse R, Bull RH, et al. The effects of aging on the cutaneous microvasculature. *J Am Acad Dermatol* 1995; 33:749-756.
70. Muhammad MI, Janjua MZ. Microscopic analysis of epidermal melanocytes in human abdominal skin. *J Coll Physicians Surg Pak* 2003; 13:79-81.
71. Pierard GE, Letawe C, Dowlati A, et al. Effect of hormone replacement therapy for menopause on the mechanical properties of skin. *J Am Geriatr Soc* 1995; 43:662-665.
72. Brincat M, Moniz CF, Studd JWW, et al. Sex hormones and skin collagen content in postmenopausal women. *Br Med J* 1983; 287:1337-1338.
73. Savvas M, Bishop J, Laurent G, et al. Type III collagen content in the skin of postmenopausal women receiving oestradiol and testosterone implants. *Br J Obstet Gynaecol* 1993; 100:154-156.
74. Pochi PE, Strauss JS. Endocrinologic control of the development and activity of the human sebaceous gland. *J Invest Dermatol* 1974; 62:191-201.
75. Courtois M, Lousouarn G, Hourseau S, et al. Periodicity in the growth and shedding of hair. *Br J Dermatol* 1996; 134:47-54.
76. Lee HJ, Ha SJ, Lee JH, et al. Hair counts from scalp biopsy specimens in Asians. *JAAD* 2002; 46:218-221.
77. Randall VA, Thornton MJ, Messenger AG, et al. Hormones and hair growth: variations in androgen receptor content of dermal

- papilla cells cultured from human and red deer (*Cervus Elaphus*) hair follicles. *J Invest Dermatol* 1993; 101:114S–120S.
78. Ruutiainen K, Erkkola R, Gronroos MA, et al. Influence of body mass index and age on the grade of hair growth in hirsute women of reproductive ages. *Fertil Steril* 1988; 50:260–265.
79. Kiesewetter F, Arai A, Schell H, et al. Sex hormones and antiandrogens influence in vitro growth of dermal papilla cells and outer root sheath keratinocytes of human hair follicles. *J Invest Dermatol* 1993; 101:98S–105S.
80. Conrad F, Ohnemus U, Bodo E, et al. Substantial sex-dependent differences in the response of human scalp hair follicles to estrogen stimulation in vitro advocate gender-tailored management of female versus male pattern balding. *J Investig Dermatol Symp Proc* 2005; 10:243–246.

# A quantitative approach to anatomy and physiology of aging skin: barrier, dermal structure, and perfusion

Jeanette M. Kamell and Howard I. Maibach

## INTRODUCTION

The anatomic facets of skin are infinite, making a complete review of age-related changes in skin structure problematic. This overview, therefore, focuses on certain readily quantifiable aspects of skin as related to structure and function. This review focuses specifically on aspects of barrier structure and function, dermal structural support, and cutaneous perfusion. Where possible, we address differences between intrinsic, physiological aging, and extrinsic aging due to photoexposure, wind, relative humidity, and other environmental factors, although we acknowledge that this distinction is not always easily made. Ultimately, we hope to unify each topic and the general understanding of skin structure and pathophysiology with respect to the aging process.

## BARRIER STRUCTURE AND FUNCTION

Much of the pathophysiology of skin aging relates to changes in barrier structure and function. Many of these changes relate to altered homeostasis of stratum corneum (SC) lipid content and SC pH. While studies of aged barrier function through quantitative measures such as transepidermal water loss (TEWL) are variable and often conflicting, altered barrier function clinically manifests in increased xerosis and altered permeability of topical agents in aged skin.

## SC Lipid Content and Homeostasis

The “brick and mortar” model is often employed to describe the SC’s protein-rich corneocytes embedded in a matrix of ceramides, cholesterol, and fatty acids, and smaller amounts of cholesterol sulfate, glucosylceramides, and phospholipids. These lipids form multilamellar sheets amidst the intercellular spaces of the SC, and are critical to the SC’s mechanical and cohesive properties, enabling it to function as an effective barrier (1). Changes in SC lipid content have been inextricably linked to xerosis and eczema, as well as many other skin conditions (1).

Table 2.1 summarizes data pertaining to skin lipids and age. Many authors agree that overall lipid content of human skin decreases with age (1,2,6), but in evaluating this literature as a whole, many confounding factors may hinder studies of skin lipids including seasonal and diurnal variation, general interindividual variation, and the use of different methodologies by different researchers.

Rogers et al. found a 30% decrease in lipids of the face, hand, and leg in older subjects, but the older group only extended to age 50. No significant change was seen in propor-

tional composition of lipid classes or ceramide species (1). Schreiner compared lipid composition in subjects aged 23 to 27 with that in subjects aged 63 to 69 (3). They did not see any overall difference in lipid quantity or composition between the groups. However, the aged group consisted of only four subjects, and again, included a narrow age range. Saint Leger et al. studied the lower legs of 50 subjects and found that the lipid profile was constant from age 50 upward; overall, aging was associated with a slight decrease in sterol esters and triglycerides (2). Cua et al. noted significant regional variation within individuals as they studied 11 sites on 29 people, comparing individuals in their third decade of life with those in their eighth. They also found little relation between skin surface lipid (SSL) content and age, except on the ankle, where the elderly demonstrated decreased lipid content (3). Ghadially et al. showed that the internal structure of lamellar bodies and their numbers in the granular layer cytoplasm is similar in aged and young skin, but that there is a paucity of secreted lamellar body contents in focal interstices of elderly skin, resulting in discontinuous distribution of otherwise normal lamellar bilayers (4).

Barrier disruption results in upregulation of enzymes involved in lipid synthesis (7), and lipid barrier repair after disruption may be delayed in elderly skin resulting in significantly decreased barrier function after minimal trauma (4,8,9). More important than overall quantitative lipid content may be homeostasis and ratio of cholesterol, ceramides, and free fatty acids to one another, particularly after barrier disruption (8,10–12). While impaired synthesis of aged human epidermal lipids following barrier disruption has not been directly shown, Ghadially et al. demonstrated impaired lipid homeostasis in a murine model (8), wherein after barrier damage, cholesterol synthesis does not keep pace with ceramide and free fatty acid synthesis, resulting in impaired barrier maintenance.

## Skin Surface pH

While study of changes in lipid structure of the SC with age are limited by both inter- and intraindividual variation (13), and may not completely account for changes in barrier function with age, SC acidity is more readily studied and is at least equally influential in the affecting the barrier status of aged skin (14). Indeed, lipid processing is directly dependent on maintenance of optimally acidic pH via activation of pH-sensitive  $\beta$ -glucocerebrosidase (14). Furthermore, elevated pH leads to activation of serine proteases which prematurely degrade corneodesmosomes, another essential SC barrier component (14). pH increases may be related to decreased expression of

**Table 2.1** Data: SC and SSL Content and Composition

Source	Methods	Results	Notes
Rogers et al., 1996 (1)	Included 28 female Caucasians aged 21–50. Studied lipid composition from eight sequential SC tape strippings of face, hand, and leg. Corneocytes were removed from the tape strippings by sonication in methanol, and lipid extracts were treated and separated using HPTLC on 20 × 10 cm plates. HPTLC plates were developed, dried, and stained, then quantitated using a scanning densitometer at 420 nm. Samples of ceramide fractions from the leg site were also used to analyze ceramide 1 esterified fatty acids in relation to age in the following groups: 26–29 ( <i>n</i> = 9), 41–43 ( <i>n</i> = 9), 57–60 ( <i>n</i> = 10).	All lipid classes decreased with increasing age (overall, saw a 30% decrease in lipid content in aged subjects). Decrease was most marked for all ceramide species (1–6) in the face and hand, and for cholesterol in the face ( <i>p</i> < .05). Percentage ratios of each of the major lipid classes and of the individual ceramide species remained constant. Esterified FA analysis: Levels of ceramide 1 linoleate decreased with increasing age. There were no significant age-related changes in ceramide 1 esterified FA or in FFA species.	This study included a fairly narrow age range and does not consider changes in elderly skin. Also, the authors only took 8 strippings from each site; this does not necessarily include the whole SC. This study did account for differences in amount of SC removed by measuring protein content in strippings and normalizing the mass of each lipid fraction removed.
Saint Leger et al., 1988 (2)	SC lipids were collected from the right and left legs of 50 subjects.	The SC lipid profile was generally constant from age 50 upward. Aging was associated with a decrease in sterol esters and triglycerides. Changes in lipids did not seem to account for the increasing xerosis in aged populations.	Study focusing on lower legs reveals no significant age-related changes.
Cua et al., 1995 (3)	Included 7 females aged 24.9 ± 1.1, 7 males aged 28.7 ± .5, 7 females aged 75.3 ± 2.4, and 8 males aged 73.8 ± 1.2 yr. Measured 11 anatomical regions' SSL contents.	SSL content was not statistically different between age groups on all regions except for the ankle, where lipid content was lower in the elderly ( <i>p</i> < .05).	No clear reason is provided as to why ankle SC lipid content may differ with age, whereas other sites did not.
Ghadially et al., 1995 (4)	Evaluation of SC lipid content in skin of 15 young (20–30 yr) and 6 elderly (>80 yr) subjects following barrier disruption using tape stripping and/or acetone. Structural analysis was performed on shave biopsy specimens of sun-protected volar skin using electron microscopy.	Internal structure of lamellar bodies and their numbers in the granular layer cytoplasm is similar in aged and young skin, but that there is a paucity of secreted lamellar body contents in focal interstices of elderly skin.	Altered secretion of lamellar bodies results in discontinuous distribution of otherwise normal lamellar bilayers was noted following barrier disruption. Limited number of subjects. Shave biopsy/not truly in vivo evaluation.
Schreiner et al., 2000 (5)	Included 10 normal subjects aged 25.5 ± 2.5, 10 subjects with dry skin aged 30 ± 6, and 4 subjects aged 66 ± 3 yr. Performed small angle X-ray diffraction and lipid analysis on whole SC samples from lower legs. Measured the percentage and quantity of different barrier lipid classes.	No significant difference in total ceramides, free sterols, and FFA's number between younger and older groups. While not statistically significant, there was an apparent increase in percentage of FFA and compensatory decrease in percent ceramides.	According to this study, lipid compositions of different skin types do not differ significantly; the aged group only consists of 4 subjects.

Note: The table presents data for age-related changes in lipid content and composition. See text for discussion.

Abbreviations: SSL, skin surface lipid; HPTLC, high performance thin layer chromatography; FA, fatty acid; FFA, free fatty acid.

an Na/H antiporter channel (NHE1) in aged skin (14). Of note, skin's acidity is also an important part of the skin surface ecosystem and a contributor to defense against microbiological or chemical insults (15), though further discussion of immunity of aged skin is beyond the scope of this chapter.

Table 2.2 summarizes data pertaining to the relation between skin pH and age.

PH appears relatively constant, at least from childhood through age 70 (16–18). However, skin surface pH rises sig-

nificantly in adults near or older than 70 years of age. Some have noticed that this effect is especially marked in lower limbs, and therefore have attributed the increased pH to stasis and reduced oxygen supply frequently observed on the lower limbs in older individuals (19). Furthermore, pH measurements taken from the skin surface should be interpreted cautiously as "apparent pH;" typical pH measurements are actually measuring extracted material of SC diffusing into water applied at the SC surface, where hydrogen ions are not in solution (20).

**Table 2.2** Data: pH

Source	Methods	Results	Notes
Fluhr et al., 2000 (16)	Measured the volar forearm of 44 adults, aged 21–44 (mean 34.6), and 44 of the adults' children, aged 1–6 (mean 3.5). Used a Skin pH-Meter to measure pH.	No significant difference in pH of children's skin vs. adults' skin.	This is not a broad enough age range to assess changes in elderly skin.
Diktein et al., 1984 (17)	Tested forehead skin of 500 female patients, aged 20–70. For pH measurement used planar dura probe electrode.	Found no significant correlation between age and pH.	This is a fairly large study over a fairly broad age spectrum.
Shoen, 1982 (18)		pH is practically constant up to the age of 70 then rises significantly above the mean value of the "below 70" age group.	
Wilhelm et al., 1991 (19)	Studied 11 anatomic locations in 14 young adults (26.7 ± 2.8 yr) and 15 aged adults (70.5 ± 13.8 yr); half of the subjects were male and half female. Measured skin pH in duplicate with flat surface glass electrode connected to a Skin pH meter.	Mean pH varied from 4.8 (ankle) to 5.5 (thigh) in the young group and from 5.0 (forehead) to 5.5 (abdomen) in aged individuals. pH was significantly higher in the aged group on the ankle and the forehead. However, on all other anatomic regions, no significant differences in skin pH were noted.	Authors possibly attribute the pH difference in the ankle to stasis and reduced oxygen supply frequently observed on the lower limbs in older individuals. Also, this data still agrees with above information because it includes adults over 70.

Note: The table summarizes data pertaining to age-related changes in skin pH. See text for discussion.

### SC Hydration and Transepidermal Water Loss

While from the above discussion one might presume decreased quantitative measurements of barrier function with aged skin, research has thus far produced conflicting, and often confusing results. Numerous studies of TEWL have shown a decrease in this parameter in aged skin compared with young skin (19,21–27), whereas others have demonstrated no significant measurable difference in TEWL in older skin (5,16,25,28–31). Measurements of SC hydration via studies of capacitance and conductance and/or spectroscopy have generally revealed significantly decreased hydration with age (5,16,29,27,32–35), though a few studies have failed to show significant difference between certain parameters of hydration of aged and young SC (16,36).

We suspect that variability in quantitative measurements of TEWL and SC hydration can be explained by the sheer complexity of skin physiology. Parameters of hydration, which one might expect to be straightforward reflections of barrier function, are undoubtedly also influenced by interindividual/site variation of SC thickness, sebum secretion, cutaneous perfusion, core body temperature, and external conditions and humidity, among many other factors (37–39).

### DERMAL STRUCTURE

Aside from the changes in SC barrier function in aged skin, measurable alterations in the dermal structural network of collagen, elastin, proteins, glycosaminoglycans (GAG), and water lead to changes in elderly skin's tensile strength and resilience.

#### Dermal Collagen

Table 2.3 summarizes data pertaining to skin collagen. Collagen, which comprises approximately 70% to 80% of the dry weight of the dermis, is primarily responsible for skin's tensile

strength. In chronologically aged skin, the rate of collagen synthesis, activity of enzymes that act in the posttranslational modification, collagen solubility, and thickness of collagen fiber bundles in the skin all decrease (48,49). Also, the ratio of type III to type I collagen increases with increasing age (42,49).

In photoaged skin, collagen fibers are fragmented, thickened, and more soluble (48). The increased fragmentation of collagen especially in photoaged skin is secondary to upregulation of collagen-degrading matrix metalloproteinases (MMP) by UV radiation (48–50). UV exposure acutely activates MMP via formation of reactive oxygen species including peroxy-nitrite (51), as well as by paracrine release of cytokines such as IL6 by keratinocytes (52,53), and more slowly via activation of multiple signaling pathways including MAP kinase pathways, ultimately stimulating increased transcription of MMP (54,55). MMP are also similarly, though more gradually, upregulated in chronologically aged photoprotected skin (51,54).

From a biochemical standpoint, chronological aging induces increased markers of oxidation, glycoxidation, lipoxidation, and glycation in skin collagen (56). In particular, skin collagen's cross-linking lysine residues undergo significant oxidative changes with age. Lysine oxidase, a copper-dependent enzyme, converts lysine to allysine at all ages. Recently it has been shown that allysine is further oxidized to a stable end product, 2-amino adipic acid. This oxidative change results in significant accumulation of 2-amino adipic acid in collagen of aged skin; increased oxidative end product is also seen in diabetes, renal failure, and sepsis (56).

Aside from increased degradation and fragmentation, aged skin exhibits decreased fibroblast function resulting in reduced collagen synthesis and replacement (57). At least one proposed mechanism involves UV-induced mitochondrial damage from reactive oxygen species triggering apoptosis of fibroblasts (54,58).

**Table 2.3** Data: Collagen

Source	Methods	Results	Notes
Shuster et al., 1975 (40)	74 Caucasian males, 80 females aged 15–93. Biopsies were taken from the midpoint of extensor aspect of forearm using high-speed 5-mm punch. Some post mortem samples were included. Samples were defatted in acetone, dried to constant weight, hydrolyzed, and their hydroxyproline content was measured.	Linear decrease in absolute collagen content with age, 1% per year. Collagen density decreases with age ( $p < .001$ ). Saw a significant relationship between skin thickness and collagen content for all males ( $p < .001$ ) and for females greater than 60 yr old ( $p < .001$ ).	Collagen decreases with age. This method may be subject to preparation artifacts.
Gniadecka et al., 1998 (41)	Study of Caucasians included 10 people aged 74–87 and 10 people aged 22–29. Obtained Raman spectra from buttock skin and forearm skin, using NIF-Raman spectroscopy.	Photoaged skin: collagen fibers are fragmented, thickened, and more soluble, elastin fibers form conglomerates, and amount of glycosaminoglycans increases. Chronologically aged skin: changes are more subtle. Despite an overall increase in number of collagen fibers, these are thinner and less soluble. Also see a relative increase with age in the collagen III/collagen I ratio.	Raman spectroscopy allows a detailed analysis without preparation artifacts. The information here agrees with many of the other studies represented in this table.
Lovell et al., 1987 (42)	Strips of abdominal skin obtained at laparotomy or post mortem from 30 subjects, age 0–90 yr. Some samples were cut and acid hydrolyzed; hydroxyproline content was determined using an automated amino acid analyzer and the total collagen calculated from hydroxyproline estimations. Collagen content was calculated both per unit weight of freeze-dried skin and per unit surface area. Other skin samples were digested with CNBr, and type I: type III ratios were calculated using SDS polyacrylamide gel electrophoresis. Pepsin digestion and HPLC separation of denatured $\alpha$ chains was also used to calculate type I: type III ratios. Indirect immunofluorescence enabled analysis of frozen skin samples antibody-labeled for types I, II, IV, and V collagens. Scanning electron microscopy was used to study the diameters of bundles of collagen fibers.	Hydroxyproline content and estimates of total collagen content did not vary significantly with age. SDS gel electrophoresis showed type III collagen content of skin samples from 2 young donors (age 5) was 20–23%. In people aged 14–65, measurements were relatively constant; showed content of type III collagen to be 18–21.5%. In people over 65 there was greater variation, levels of type III were increased and as high as 31%. The HPLC method was less conclusive because pepsin digestion and separation of collagen component chains was incomplete, especially in skin samples from older individuals. Immunofluorescence data showed no gross changes in distribution of the various collagen types during aging. Scanning electron microscopy: decrease in number of collagen fiber bundles per unit area in the papillary area with increasing age. The oldest subject (82 yr) had reduced bundle width ( $p < .0001$ ) compared with 4 other subjects aged 15–58.	Electron microscopy measurements represented a small study population and are therefore somewhat questionable ( $n = 5$ ). Hydroxyproline approximations of collagen content appear more reliable, as they include 29 subjects, dispersed between age 3 mo and 82 yr; however, this still reflects a small number of subjects in any given age range. The shift in collagen type with aging prompts the question of whether this was due to increased type III synthesis or decreased type I synthesis. This study does not provide an answer.
Fisher et al., 1996 (43)	Adult buttock skin (number of subjects not clarified) was irradiated with 2 MED UVB in vivo (twice the dose required to cause barely perceptible reddening). Irradiated and adjacent nonirradiated sites were removed at various times following irradiation and snap-frozen. RNA contents were then analyzed using northern blot. Band intensities were quantified using a PhosphorImager. Protein content in skin was quantified using western blot. Nuclear extracts from irradiated and nonirradiated skin were also temporally analyzed for AP-1 and NF- $\kappa$ B binding to double-stranded DNA probes were measured by electrophoretic mobility-shift assays.	Transcription factors NF- $\kappa$ B and AP-1 showed 2.5- to 3-fold increased binding to DNA within 15 min of irradiation, lasting up to 4 hr after irradiation. Induction of interstitial collagenase, streptomelysin 1, and 92-kd gelatinase mRNAs was maximal (6–60 fold, $p < 0.05$ ) at 16–24 hr, and returned to near baseline within 48–72 hr. 72-kd gelatinase mRNA was detectable but was only elevated 1.6 fold at 24 hr post UVB exposure. Confirmation that mRNA rises corresponded with actual collagenase protein rises was done using western blot.	Within minutes of UVB exposure, transcription factors AP-1 and NF- $\kappa$ B showed increased binding to DNA, stimulating synthesis of various collagenase mRNAs, which resulted in increased synthesis of collagenase proteins. Authors provide direct, in vivo mechanistic evidence of UVB exposure's resulting in increased collagenases in skin.

(continued)



**Table 2.3** Data: Collagen (*Continued*)

Source	Methods	Results	Notes
Fisher et al., 1997 (44)	Caucasian adults underwent irradiation of skin at four separate buttock sites, with each site exposed one, two, three, or four times to radiation delivered at 48-hr intervals at .5 MED. Skin specimens were obtained from irradiated and adjacent nonirradiated sites at 24 hr after the last exposure.	After a single exposure to UV irradiation, collagenase and 92-kd gelatinase activity was elevated 4.4 $\pm$ 0.2 times the value in nonirradiated skin and 2.3 $\pm$ 0.4 times, respectively. Collagenase and gelatinase activity remained maximally elevated after the second, third, and fourth exposures on days 3, 5, and 7, respectively.	Repeated UV exposure leads to sustained induction of the MMP.
Varani et al., 2000 (45)	72 subjects provided skin samples from sun-protected areas; age groups compared were 18–29, 30–59, 60–79, and 80+. Levels of MMP-1 were assessed using western blot, and levels of MMP-9 and MMP-2 were assessed using gelatin zymography with scanning laser densitometry for quantitation. Levels of types 1 and 3 procollagen were measured using western blot.	In the 80+-yr-old group compared with the 18- to 29-yr-old group, there was a 40%, 52%, and 82% increase in MMP 1, 9, and 2, respectively ( $p < 0.01, 0.05, \text{ and } 0.001$ ). In the 60- to 79-yr-old group compared with the 18- to 29-yr-old group, there was a 23%, 20%, and 44% increase in MMP 1, 9, and 2, respectively ( $p < 0.05, \text{ NS, and } p < 0.05, \text{ respectively}$ ). There was a 52% decrease in type 1 procollagen expression in 80+ yr-olds vs. 18- to 29-yr-olds ( $p = 0.022$ ).	Chronological aging results in elevated expression of MMP and decreased expression of types 1 and 3 procollagen.
Varani et al., 2006 (46)	Young (18–29 yr) vs. old (80+ yr) subjects participated. Replicate 2- and/or 4-mm punch biopsies of sun-protected hip skin were obtained from each individual. 4-mm punches were used for fluorescence microscopic and ultrastructural analysis and for assessment of type 1 procollagen levels. 2-mm biopsies were used for routine light microscopy and for isolation of dermal fibroblasts in culture.	Fibroblasts from young skin produced greater type 1 procollagen than those from old skin ( $82 \pm 16 \text{ vs. } 56 \pm 8 \text{ ng/mL}$ , $p < 0.05$ ). A reduction in mechanical stimulation in chronologically aged skin was inferred from greater percentage of cell surface attached to collagen fibers ( $78\% \pm 6\% \text{ vs. } 56\% \pm 8\%$ , $p < 0.01$ ) and more extensive cell spreading ( $1.0 \pm 0.3 \text{ vs. } 0.5 \pm 0.3$ , $p < 0.05$ ) in young vs. old skin.	Authors hypothesize that old fibroblasts have an age-dependent reduction in the capacity for collagen synthesis while simultaneously experiencing a loss in mechanical stimulation resulting from fewer intact collagen fibers.
Sell et al., 2007 (47)	Human skin samples from 117 people, aged 10–90 yr, were obtained at autopsy. Amounts of 2-aminoadipic acid and 6-hydroxynorleucine (a marker of allysine) in the collagen were determined in acid hydrosylates of processed samples using ion-monitoring gas chromatography. Quantitative contents of 2-aminoadipic acid and 6-hydroxynorleucine were compared in young and old subjects as well as in those with histories of diabetes, renal failure, and sepsis.	2-aminoadipic acid ( $p < 0.0001$ ), but not 6-hydroxynorleucine ( $p = 0.14$ ) significantly increased with age, reaching levels of 1 and 0.3 mmol/mol lysine at late age (mean 82), respectively. Significant increased in 2-aminoadipic acid, but not 6-hydroxynorleucine, were also seen in patients with diabetes ( $p < 0.0001$ , levels of 2-aminoadipic acid up to $<3 \text{ mmol/mol}$ ), renal failure (levels of 2-aminoadipic acid up to 8 mmol/mol), and especially sepsis ( $p = 0.0001$ ).	2-Aminoadipic acid, a pan-marker for all forms of lysine oxidation, significantly increased in aging human skin. Levels of its precursor, allysine, are in steady-state suggesting ongoing oxidation of allysine to form the stable end product, 2-aminoadipic acid.

Note: The table presents data on age-related changes in elastin structure. See text for discussion.

**Abbreviations:** MMP, matrix metalloproteinases; MED, minimal erythemogenic dose; SDS, sodium dodecyl sulfate; HPLC, high performance lipid chromatography.

Histological data (41,59) reflects the impacts these biochemical changes ultimately have on the orientation and arrangement of collagen fibers in skin. Lavker et al. compared skin from the upper inner arm of old (age 70–85) and young (age 19–25) individuals using light, transmission electron, and scanning electron microscopy (59). In aged skin, the density of the collagen bundle network appears artifactually increased because of a decrease in ground substance (59), and rather than appearing in discrete rope-like bundles of tightly packed fibers, collagen forms aggregates of loosely woven, mostly straight fibers in elderly skin. As fibers become straighter in aged skin, there is less room for the skin to be stretched, so tensile strength decreases (59).

Hence both on biochemical and microscopic levels, reduced collagen deposition and enhanced degradation of collagen contribute to development of dermal atrophy, wrinkles, decreased tensile strength, and poorer wound healing in the elderly.

### Dermal Elastin

Table 2.4 summarizes skin elastin data. The skin's intact elastic fiber network, which occupies approximately 2% to 4% of the dermis by volume, provides resilience and suppleness. This network shows definite changes associated with aging, especially between the ages of 30 and 70. Accumulation of new elastin in response to photoaging is also apparent from

upregulation of the elastin promoter activity and increased abundance of elastin mRNA (60,62). Bernstein et al. compared photoaged with intrinsically aged skin, and found a 2.6-fold increase in elastin mRNA, a 5.3-fold increase in elastin expression, and a 5-fold increase in elastin promoter activity in photodamaged skin (62). However, these apparent increases

in elastin synthesis do not account for the massive accumulation of elastotic material seen histologically in photoaged skin (62). Some attribute this to elastin degradation being slower than synthesis, leading to an accumulation of partially degraded fibers. Recent work has revealed that proteins such as elafin and lysozyme, expression of which is induced by UVA

**Table 2.4** Data: Elastin

Source	Methods	Results	Notes
Robert et al., 1988 (57)	Analyzed 6-mm punch biopsies of skin from buttock and upper inner arm of 50 individuals (40 males, 10 females). Used a specific elastic staining procedure, then automated computerized image analysis. Calculated percent surface area covered by elastic fibers, length, and number of elastic fibers per unit surface area in superficial (papillary) and deep (reticular) dermis as a function of age.	Percent surface area coverage by elastic fibers increased with age in superficial and deep dermis: Males: superficial dermis, $r = .66$ , $p < .001$ . Deep dermis, $r = .56$ , $p < .01$ . Similar correlation in females did not reach significance because of small sample size. Mean fiber length also increased with age in the superficial and deep dermis: $r = .036$ , $p < .02$ . Number of elastic fibers per unit surface area showed no significant change with age in either the superficial or deep dermis.	Continuous increase with age in the length and relative surface area of elastic fibers. This appears to contradict these authors' rheological studies on the same patients that show a continuous decrease in skin elasticity with age (60). The authors attribute this to the possibility of continuous enrichment with age in polar amino acids, carbohydrates, lipids, and calcium of the skin elastic fibers. These structural changes in elastic fibers may interfere with their proper functioning.
Ritz-Timme et al., 2003 (60)	2 × 2 cm skin samples were taken from ventral abdomen during autopsy. Paraffin sections of all samples were examined histologically. Then elastin was purified and AAR was quantified. Specific ages are not given.	In total skin, specimens displayed slight age-dependent increases in D-aspartyl residues; in purified elastin the rate of increase was rapid and highly correlated with age ( $r = .98$ ).	This paper goes into great detail which is beyond the scope of this overview, but does provide interesting insight into elastin degradation.
Ritz-Timme et al., 2002 (61)	Review paper.	Accumulation of new elastin in response to photoaging can be seen from upregulation of the elastin promoter activity and increased abundance of elastin mRNA. However, de novo synthesis of elastin in adult tissues is ineffective.	This paper provides a review of aspartic acid racemization and its role in skin aging.
Bernstein et al., 1994 (62)	16 males aged 49–66. 4-mm punch biopsies taken from the sun-damaged neck and photoprotected buttock. Studied samples using Northern blot analyses, transient transfections with a human elastin promoter/reporter gene, and immunohistochemical staining with elastin and fibrillin antibodies. Analyzed samples in pairs to determine effects of photoaging.	Northern analysis of frozen sections: up to a 2.6-fold increase in elastin mRNA in exposed vs. nonexposed skin. Analysis of mRNA from fibroblast cultures: 5.3-fold increase in elastin expression and 2.5-fold increase in fibrillin expression in photodamaged skin. Transient transfection of cultured cells revealed 5-fold increase in elastin promoter activity. Score for elastin staining in superficial dermis, protected skin: $.62 \pm .52$ exposed skin: $5.0 \pm .76$ ( $n = 8$ , $p < .000,001$ ).  Score for fibrillin staining in superficial dermis protected skin: $.75 \pm .46$ photoaged skin: $3.1 \pm .64$ ( $p < .0001$ ).	This study does not include a very broad age range. Also, since it used several different methods to establish mechanistic details, each method had a very small sample size (3 in Northern Blot analysis of total RNA from frozen sections, 3 in Northern Blot analysis of fibroblast culture, 2 for transient transfection method, and 8 for immunohistostaining method). The increase in elastin promoter activity and mRNA do not account for the degree of accumulation of elastotic material seen histologically in superficial and mid dermis of photoaged skin. It is suggested that most of the material staining as elastin in photoaged skin is structurally abnormal. Authors propose that elastin degradation may be slower than production, with accumulation of partially degraded elastic fibers.

(continued)

**Table 2.4** Data: Elastin (*Continued*)

Source	Methods	Results	Notes
Seite et al., 2006 (63)	91 skin biopsies from unexposed (buttock area) skin aged 21–80 yr, 30 specimens from semiexposed (forearm) skin aged 22–64 yr, and 24 specimens from severe exposure (facial) skin aged 45–65 yr. UV exposure's (280–400 nm) influence on lysozyme deposition measured using 122 samples from buttock skin aged 20–40 yr. Measurement of elastin and lysozyme via direct immunofluorescence with computer-aided quantitation.	Reduced elastin content with age in buttock skin (groups aged 61–80 had significantly less elastin than groups aged 21–50 yr). Relative amount of elastin in the face of subjects aged 51–70 were abnormally high compared with buttock and forearm skin of those age groups. UVA (320–400 nm), especially long wave UVA (340–400 nm) induces lysozyme deposition in elastin fibers to a significantly greater extent than simulated solar radiation (280–400 nm). 25% of elastin fibers in buttock skin were covered with lysozyme, compared with 66% of elastin fibers in facial skin, supporting the association of lysozyme with solar elastosis. Lysozyme was shown to inhibit degradation of elastin fibers by human leukocyte esterase.	Authors use an ample sample size and explain their methodology thoroughly to reveal mechanistic explanation for solar elastosis based on increased deposition of lysozyme in sun-exposed skin; lysozyme inhibits human leukocyte esterase to prevent proper degradation of elastin and allow accumulation of partially degraded fibers. The lower elastin content in sun-protected, older skin compared with sun-protected younger skin implies that human leukocyte esterase naturally works uninhibited to reduce elastin content with age, however the UV-induced accumulation of lysozyme inhibits elastin's degradation with age in sun-exposed skin.

Note: The table presents data on age-related changes in elastin structure. See text for discussion.

radiation, prevent elastin degradation by human leukocyte (neutrophil) elastase (62). In purified skin elastin, the amount of racemized aspartic acid increases rapidly and is highly correlated with age ( $r = .98$ ) (60). This indicates that skin's elastin, like elastin in the aorta and lung, is long-lived and accumulates damage over time (57,59).

Computerized image analysis of elastin-stained skin biopsies from photoprotected sites reveals an age-related increase in mean elastin fiber length and percentage surface area coverage in the dermis, but these fibers are thought to be abnormally enriched in polar amino acids, carbohydrates, lipids, and calcium (57). The finer oxytalan fibers in the papillary dermis are depleted or lost altogether; eluanin and elastic fibers become progressively abnormal (57).

Elastin, therefore, exhibits numerous age-related changes, including slow degradation and accumulation of damage in existing elastin with intrinsic aging, increased synthesis of apparently abnormal elastin in photoexposed areas, and abnormal localization of elastin in the upper dermis of photodamaged skin. These factors lead to the histologically evident elastotic accumulation and contribute to characteristic clinically appreciated changes of elderly skin being more lax and more prone to wrinkles.

### Proteins, Glycosaminoglycans, and Water

Table 2.5 summarizes data pertaining to other skin protein structure.

Through Raman spectroscopy, little difference is seen between photoexposed and protected areas in young individuals; the majority of proteins in young skin are in helical conformation. Intrinsically aged skin shows slightly altered protein structure, and photoaged skin reveals markedly altered protein conformation, with increased folding and less exposure of aliphatic residues to water (41,64). Amino acid composition of proteins and free amino acids (FAA) in aged skin also differ significantly from

that of young skin, including an increase in overall hydrophobicity of amino acid fractions from the elderly (56). Since FAA are believed to play a key role in SC water binding, this shift in their composition, combined with the evidence of altered tertiary protein structure, provides insight into the increased incidence of xerosis in aged individuals.

The content and distribution GAG, especially hyaluronic acid, also impact skin hydration (66). Table 2.6 summarizes data regarding GAG. Quantitatively, GAG increase in photoaged skin compared with young or intrinsically aged skin (64,66). This seems paradoxical, as photoaged skin appears leathery and dry, unlike newborn skin, which also contains high levels of GAG. Confocal laser scanning microscopy reveals that GAG in photodamaged skin are abnormally deposited on elastotic material, rather than diffusely scattered as in young skin (66). This aberrant localization may interfere with normal water binding by GAG, despite their increased number.

In young skin, most of water is bound to proteins and, appropriately, is called bound water (41). This is important for the structure and mechanical properties of many proteins and their mutual interactions. Water molecules not bound to proteins bind to each other, and are called tetrahedron or bulk water (41). Data pertaining to water structure and aging is summarized in Table 2.7. Intrinsic aging does not appear to alter water structure significantly (64). However, in photoaged skin, Raman spectroscopy reveals an increase in total water content. Again, this seems paradoxical, as aged skin is often dry and weathered. However, structurally, significantly more of the water in aged skin is in tetrahedron form. Thus, as proteins are more hydrophobic and folded, and GAG are clumped on elastotic material, they interact less with water, and water in aged skin binds to itself instead. This lack of interaction between water and surrounding molecules in photoaged skin likely contribute to its tendency toward a more dry and wrinkled appearance.

**Table 2.5** Data: General Protein Structure

Source	Methods	Results	Notes
Gniadecka et al., 1998 (64)	Study of Caucasians included 10 people aged 74–87 and 10 people aged 22–29. Obtained Raman spectra from buttock skin and forearm skin, using NIF-Raman spectroscopy.	Young group: Little difference in spectra of photoexposed vs. photoprotected sites. Most skin proteins were in a helical conformation. Older group: Intrinsically aged (buttock) skin: resembled young dorsal forearm or buttock, except for a significant ( $p = .008$ ) shift of amide I peak position toward lower frequencies in older skin, suggesting minor conformational changes of protein structure. Photoaged (dorsal forearm) skin: In addition to the amide I band, the amide III band was also significantly shifted to lower frequency compared with aged photoprotected and younger skin spectra. Also, decreased intensity of the amide III band indicated severe conformational changes in protein in structure, with an increase in protein folding and less exposure of aliphatic amino acids to surrounding water.	In young skin most proteins are in helical structure and we do not see much difference between sun-exposed and sun-protected regions. Chronologically aged skin has proteins in slightly altered conformation. Photoaged skin has proteins in markedly altered conformation, with increased folding and less exposure of aliphatic residues to water. This enables the proteins in photoaged skin to bind less water.
Jacobson et al., 1990 (56)	Amino acid composition was quantified in 3 fractions isolated from scales of SC from the lower leg. The three fractions studied were FAA, soluble hydrolysate, and whole cell hydrolysate. “Old” subjects ( $n = 20$ ) were 60 yr or older; “young” subjects ( $n = 20$ ) were 30 yr or younger.	In normal subjects, each of the 3 fractions showed significant difference ( $p < .03$ ) in amino acid composition as a function of age. The FAA and SH fractions revealed an increase in hydrophobic amino acids.	This is an interesting study that goes into great detail regarding specific amino acid composition, which is beyond the scope of this overview. Nonetheless, the general shift toward increased hydrophobicity is an important trend that should be noted.
Gniadecka et al., 1998 (41)	Used NIR-FT Raman spectroscopy to examine 3-mm punch biopsies from buttock, lower leg, back, and arm in 44 individuals aged 18–35.	Most proteins in the whole skin and SC were in $\alpha$ helix conformation. This was supported by the frequencies of amide I and III maxima and by a strong C-C stretch band at 935/cm.	This data further supports that in young skin, proteins are mostly in $\alpha$ -helical conformation.
Sander et al., 2006 (65)	Evaluated buttock skin and photoexposed skin of 12 young (<30 yr) and 12 older (66–73 yr) subjects. ECM1 expression was investigated using immunohistochemistry with densitometric image analysis for semiquantitative results. Acute UV exposure was created by irradiating buttock skin over 10 days with a solar simulator.	In normal human skin ECM1 is expressed mainly in basal cell layers of epidermal keratinocytes and dermal vessels. Intrinsically aged, UV-protected skin showed a significantly reduced expression in basal (~10% decreased staining intensity) and upper (~8% decreased staining intensity) epidermal cell layers compared with young skin ( $p < 0.05$ ). In photoaged skin expression is significantly increased in the lower (~15% increased staining) and upper (~18% increased staining) epidermis compared with age-matched UV-protected sites ( $p < 0.01$ ). Acute photoexposure also results in marked increased epidermal ECM1 expression (~8–10%, $p < 0.05$ ).	Semiquantitative data reveals acute and chronic UV-related stress appears to influence expression and distribution of ECM1. Future studies may reveal similar impacts of intrinsic and photoaging on other skin proteins.

Note: The table presents age-related data on generalized dermal protein structure. See text for discussion.  
Abbreviation: FAA, free amino acids.

**Table 2.6** Data: GAG

Source	Methods	Results	Notes
Bernstein et al., 1996 (66)	Included 6 males aged 52–60, with significant photodamage. 4-mm punch biopsies were taken from the sun-damaged posterior neck and sun-protected buttock. Histometrically studied GAG content of papillary dermis using immunoperoxidase stains specific for hyaluronic acid and chondroitin sulfate. Expressed measurements as percentage of fields stained positively for these GAG. Studied location of GAG using confocal laser scanning microscopy, staining specifically for GAG and elastin.	Significant increase in GAG staining in sun-damaged vs. sun-protected skin from the same individuals. Hyaluronic acid Sun protected: 13.7% ± 1% Sun exposed: 24.4% ± .5% ( $p < .05$ ). Chondroitin sulfate Sun protected: 6.7% ± .25% Sun damaged: 23.37% ± .6% ( $p < .0001$ ) Superficial dermal GAG in sun-damaged skin are clumped and deposited almost exclusively on the solar elastotic material, rather than diffusely between the fine network of collagen and elastic fibers as in normal (photoprotected) skin, wherein concentration of dermal GAG is greatest just beneath the epidermis and decreases gradually with increasing depth.	One would expect that increased GAG content would give skin a youthful appearance, as it does in newborn skin. These authors state that the abnormal location of GAG in photodamaged skin may explain the apparently paradoxical weathered, appearance of photodamaged skin despite increased GAG. This study does not consider possible anatomical variation between neck and buttock, separate from the factor of photodamage. Comparison. Furthermore, the narrow 52–60 age range limits the study to one of photoaging and does not consider intrinsic aging.
Takahashi et al., 1996 (67)	To quantify main disaccharide units of skin GAG, used high performance lipid chromatography after labeling with 1-phenyl 3-methyl 5-pyrazolone. After comparing 6 “sun-exposed people” to 6 other “sun-protected people,” the authors compared sun-exposed and sun-protected skin within 6 individuals. Ages? Body site?	Total amount of disaccharide units in sun-exposed skin was significantly greater than sun-protected skin ( $p < .05$ ). Also saw a decrease in ratio of ( $\delta$ )Di-hyaluronic acid (HA)/ $\delta$ Di-dermatan sulfate (DS) in photoaged skin.	This article addresses photoaging but not intrinsic aging. The increase in GAG in photodamaged skin agrees with results from Bernstein et al. (above). The significance of the increased hyaluronic acid/dermatan sulfate ratio is unclear.
Lochner et al., 2007 (68)	Full thickness punch biopsies isolated from human buttock skin of 5 young (21–35 yr) and 5 older (61–68 yr) subjects. Distribution and expression of collagens 1 and 3 and decorin mRNA were measured using laser capture microdissection-quantitative real time-polymerase chain reaction in young vs. old subjects. Decorin and collagen expression were also measured before and after single exposure with two minimal erythema doses of simulated solar irradiation after 24 hr.	Decorin mRNA is expressed in the reticular but not the papillary dermis. Expression is 105% higher in older than in younger subjects. Simulated solar exposure resulted in downregulation of decorin mRNA in both groups (–35% in young, –35% in older). Collagens I and III expression were down-regulated with increasing age (29% and 60% lower levels in collagens I, and III mRNA, respectively, in older subjects compared with young) and after single UV irradiation (21% decrease seen with collagen I and 60% seen with collagen III).	Small sample size, but otherwise convincing evidence of decreased expression of decorin and collagens I and III with age and also with UV radiation. The exact mechanistic significance is unclear, but authors concluded that decreasing collagen-to-decorin ratio inflected by both age and UV irradiation may affect collagen bundle diameter in aging skin.

Note: The table summarizes data on age-related changes in GAG structure and localization. See text for discussion.

Abbreviation: GAG, glycosaminoglycans.

## CUTANEOUS PERFUSION

The epidermal and dermal structural changes noted above are further accompanied by changes in the perfusion of elderly skin. Altered perfusion is implicated in temperature regulation, perfusion of nutrients, and wound healing of elderly skin.

Cutaneous blood perfusion is intimately connected both to wound healing and thermal regulation, and has been quantitatively studied *in vitro* as well as *in vivo*. Table 2.8

summarizes blood flow data determined from several methodologies. Results of studies using laser Doppler velocimetry (LDV) or laser Doppler flowmetry (LDF) are mixed; this often appears to be the result of varying age ranges and small sample sizes. Fluhr et al. found no significant difference in cutaneous blood flow of children versus adults, but this did not allow for an assessment of changes in elderly skin because the average age of the older group was only 44 years (5).

**Table 2.7** Data: Water Structure

Source	Methods	Results	Notes
Gniadecka et al., 1998 (64)	Study of Caucasians included 10 people aged 74–87 and 10 people aged 22–29. Obtained Raman spectra from buttock skin and dorsal forearm skin, using NIF-Raman spectroscopy.	Younger group Most water molecules in young skin were bound to other macromolecules (the 180/cm band was absent). Saw no significant difference in water content or structure in sun-exposed vs. sun-protected skin. Older group Intrinsically aged (buttock) skin: No significant difference in water content or structure compared with young skin. Photoaged (dorsal forearm) skin: Increased content of nonbounded water (180/cm band present). Total hydrogen bonded water is significantly decreased in photoaged skin ( $p = .03$ ). Saw an overall (30%) increase in water content of photoaged skin.	In young skin, water is primarily present in bound form. This does not appear to change with intrinsic aging. However, in photoaged skin, overall water content increases and proportionally shifts such that less of it is in bound form.
Gniadecka et al., 1998 (41)	Used NIR-FT Raman spectroscopy to examine 3-mm punch biopsies from the buttock, lower leg, back, and arm in 44 people aged 18–35.	Over 90% of water in whole skin is present in the bound form.	This data supports that in young people, water is mainly present bound to macromolecules.
Wright et al., 1998 (69)	MRI chemical shift imaging was used to noninvasively study nine volunteers of both sexes (ages?). Obtained localized IH spectra of the skin, quantified free water content, normalized to skin thickness.	Relative concentration of free water in the skin, normalized to skin thickness, was slightly greater in older subjects and in tanned subjects.	Need more details—will have paper by 9/13, will fill in details on proofs.

Note: The table presents data pertaining to age and dermal water structure. See text for discussion.  
Abbreviation: IH, immunohistochemical.

Likewise, Kelly et al. found little difference in blood flow between young (age 18–26) and elderly (age 65–88) subjects; however, the inclusion of only 10 subjects in each age group limits interpretation of results (71). An LDF study of 201 people aged 10 to 89 revealed that areas with high blood flow, such as the lip, cushion of the third finger, nasal tip and forehead, blood flow decreased with age (74). However, in areas where the cutaneous blood perfusion was initially lower, such as the trunk, no clear variation occurred with age (74). This study also measured cutaneous blood flow and surface temperature in finger cushions for 20 minutes after a 10-minute immersion in 10°C water. The decrease in blood flow after immersion was greater in people over 50, and the restorative ability poorer in those over 70, compared with subjects younger than 50 (71). Another LDV study found that skin's vasodilation response to heat stress and vasoconstriction in response to cold challenge appears delayed in elderly (age 70–83) subjects, indicating a possibly reduced vessel density in aged skin (70). Again, this study only included 9 to 10 people from young and old age groups, so it may not provide the most conclusive answer to the question the effect of age on cutaneous perfusion. More recently, Thompson et al. explained that age-related decrements in sympathetic neurotransmission contribute directly to thermoregulatory impairment when ambient temperature causes whole-body cooling, whereas changes in local cold-induced intracellular signaling represent a more generalized age-associated vascular dysfunction (75).

Intravital capillaroscopy measurements of 26 subjects using fluorescein angiography and native microscopy suggest a decrease in dermal papillary loops and little change in horizontal vessels (postcapillary venules, ascending arterioles, and part of subpapillary plexus) with increasing age (71). An immunohistochemical study of 19 individuals ranging from age 20 to 84 revealed little effect of intrinsic aging of buttock skin on blood perfusion, but progressive and marked decrease in cutaneous perfusion in the photoaged eye corners (72). A photoplethysmographic study including 69 individuals aged 3 to 99 revealed significantly decreased capillary circulation in forehead skin with advancing age. Of interest, recent data demonstrates that acute UV exposure actually increases angiogenesis via upregulation of VEGF via the MEK/ERK pathways and through TSP-1 downregulation via PI3K-Akt activation (76). However, the resultant newly increased vasculature is hyperpermeable and more prone to release inflammatory cells, which contribute to increased expression of proteases. Over time this damages the extracellular matrix and leads to a less permissive environment for maintenance of healthy vessels seen in chronically sun-damaged skin (76).

Hence it appears that increased age may be ultimately associated with decreased cutaneous perfusion, especially in chronically photoexposed areas. Furthermore, stresses such as temperature alterations are not met with the same adaptive responses in dermal blood flow in aged skin. These findings may provide partial physiological explanation for delayed wound healing in elderly skin (77–80).

**Table 2.8** Data: Cutaneous Blood Perfusion

Source	Methods	Results	Notes
Fluhr et al., 2000 (16)	Measured the volar forearm of 44 adults, aged 21–44 (mean 34.6), and 44 of the adults' children, aged 1–6 (mean 3.5). Measured blood flow by laser Doppler flowmetry LDF-PF2.	Children had significantly higher blood flow than adults. Children (%): 24.6 Adults: 18.7 $p = .004$ .	Adults are relatively young here; the oldest adult is 44 yr of age.
Tolino et al., 1988 (70)	Studied 9 healthy men aged 70–83, and 10 men aged 20–30. Studied at ambient temperature of 20°C and 25°C during warm (41°C) and cool (12°C) water immersion challenges. Lower legs and right arm and hand were immersed. Blood flow was measured continuously in both forearms by laser Doppler velocimetry.	Immersion in 41°C water lead to peak erythrocyte flux values of Young: 140.4 ± 16.1 mV Elderly: 111.1 ± 17.9 mV, $p < .05$ . Before immersion in 12°C water, baseline flux were Young: 36.4 ± 3.3 mV Elderly: 28.7 ± 3 mV. After 12°C water immersion, fluxes fell to Young: 16.2 ± 2.4 mV Elderly: 17.9 ± 2.5 mV Fall of erythrocyte flux due to cold water submersion is greater in young subjects ( $p < .05$ ).	This study covers a wider distribution of age and may accurately reflect changes in elderly men's skin. Authors conclude that peak vasodilator response to direct heat is blunted in aging and may correspond to loss of skin blood vessels. Also, the proportional response to direct cold challenge is less in the elderly than in the young.
Kelly et al., 1995 (71)	10 young (age 18–26) and 10 old (age 65–88) subjects. Used a laser Doppler flowmeter, attaching one probe to the forehead and one to the ventral forearm. Basal flow levels were recorded, then blood flow was occluded for 3 min. After 3 min pressure was removed, resulting in post ischemic reactive hyperemia.	No significant difference was seen between old and young subjects in either the forehead or forearm in basal flow level, reactive hyperemic peak flow, time taken to return from the peak to a new baseline, and area under the post hyperemic curve. Time taken from pressure release to reach post hyperemic peak was less in the elderly forehead ( $p = .056$ ), consistent with more rapid vasodilation. This was not seen in the forearm.	This study finds no significant difference between blood flow in young and elderly except for more rapid vasodilation in response to pressure removal in the forehead, and this result was barely significant. Sample size was fairly small.
Kelly et al., 1995 (71)	Studied Caucasian men and women; 13 subjects aged 65–88 (mean 74.9), 13 subjects aged 18–26 (23.2). Studied forehead and ventral forearm using intravital capillaroscopy with fluorescein angiography. Counted dermal papillary loops as dots, representing nutritional exchange vessels. Counted horizontal vessels as lines, representing postcapillary venules, ascending arterioles, and part of subpapillary plexus.	Elderly forehead: 40% decrease ( $p = .0001$ ) in dermal papillary loops. No significant difference in horizontal vessels, compared with the young. Elderly forearm: 37% decrease in dermal papillary loops ( $p = .0005$ ). No significant change in horizontal vessels, compared with the young.	This study includes a broad age range and both sexes, but not a large sample size. Forehead data corroborates well with prior native microscopy data from same group.
Chung et al., 2002 (72)	Included 6 people aged 20–39, 9 people aged 40–69, and 6 people aged 70–84. Obtained 2- and 4-mm punch biopsy specimens from eye corners and buttock. Stained sections for CD31. Blinded, computer assisted-morphometric analysis of sections for analysis of vessel numbers, vessel size, and cutaneous coverage of immunostained vessels.	Buttock, intrinsically aged: No major reduction of vessel numbers. Average vessel size decreased 30.6% in 40–69 age group and 30.8% in 70–84 age group compared with the young group (both $p < .01$ ). Moderate changes in the cutaneous area covered by the CD31-positive vessels did not reach significance. Eye corners, photoaged: Vessel numbers reduced by 43.1% in 70–84 age group compared with young group ( $p < .001$ ). Average vessel size decreased 38.1% in 40–69 age group, ( $p < .01$ ) with a 45.3% decrease after age 70 ( $p = .001$ ). Average dermal area covered by vessels decreased 43% in 40–69 age group ( $p = .02$ ) and by 69.5% in group over 70 yr ( $p < .001$ ). Linear regression analysis: inverse relation with age of sun-damaged skin: vessel # ( $r = .83$ ), size ( $r = .814$ ), and area coverage ( $r = .879$ ).	Authors state that average dermal area covered by vessels is the most sensitive parameter for measuring skin vascularity. Conclusions: Essentially, intrinsic aging has little effect on cutaneous blood vessels. All vasculature parameters measured in photoaged skin decreased progressively with increased age.

**Table 2.8** (Continued)

Source	Methods	Results	Notes
Leveque et al., 1984 (73)	Studied 69 people, both sexes, aged 3–99. Recorded photoplethysmographic signal. The measurement head, weighing about 10 g, was fixed with double adhesive tape to the middle of the forehead. Blood pressure on the arm was also taken.	Photoplethysmographic signal “increased strongly after 60 years of age.” Specific numbers are not given. No correlation seen with blood pressure.	Authors note that diminished capillary circulation with age permits a stronger penetration of light to the dermal level. Hence increased photoplethysmographic signal reflects decreased capillary circulation with advanced age in forehead skin. Informative age range and sample size.

Note: The table summarizes age-related cutaneous blood perfusion data using studies of varying methodologies. See text for discussion.

## CONCLUSIONS

Clinically evident physiological and pathological changes in elderly skin may in part be understood on the basis of age-related structural alterations. Our discussion focuses on age-related changes in components of the SC which contribute to its barrier function, components of the dermis which contribute to its role in structural support, and alterations in cutaneous perfusion necessary to provision of nutrients and oxygen, thermoregulation, and wound healing.

While somewhat limited by interindividual variation, many studies have demonstrated either a decrease in SC lipid content or altered distribution of lamellar granules within the SC of aged skin. Of crucial importance is the ratio of cholesterol, ceramides, and free fatty acids, and the homeostasis and turnover of SC lipids, which may also be altered in aging skin. The skin surface pH also contributes greatly to barrier function; most studies concur that pH remains relatively stable until approximately age 70, after which point pH increases with age. This increased pH leads to activation of enzymes involved in lipid and corneodesmosome degradation. While one might expect quantitative measures of barrier function to reveal impaired barrier function of elderly skin, studies have vastly conflicted and may be complicated by factors such as inter- and intraindividual variation, sebum and sweat production, and influences of ambient temperature and humidity.

In terms of dermal structural support, collagen becomes less soluble, thinner, and sparser in intrinsically aged skin, but is thickened, fragmented, and more soluble with photoaging. UV exposure activates transcription factors stimulating increased production of collagenases and MMP, with subsequent breakdown of skin collagen and other proteins. Elastin, a long-lived protein, accumulates damage with age and sun exposure. New elastin is synthesized in greater quantities in aged skin, but its structure is abnormal. Furthermore, elastin degradation does not appear to keep pace with new synthesis in aged skin. This results in massive accumulations of elastotic material, especially in photoaged skin; degradation is further impaired by UV-induced expression of proteins elafin and lysozyme. Structural alterations therefore lead to impaired structural support and elasticity of aged skin.

Studies of primary and tertiary skin protein structure in aged skin reveal an environment unfriendly to water, with an overall increase in hydrophobic amino acids and greater folding such that aliphatic residues are more hidden from water. While total GAG appear quantitatively increased in age skin, these are abnormally localized on the elastotic material in the superficial dermis; thus they are unable to bind water as well as

if they were scattered appropriately throughout the whole dermis. Hence, although aged skin contains increased amounts of water, most of this water is bound to itself in tetrahedral form, rather than being bound to proteins and GAG as it is in young skin. These factors together may contribute to increased xerosis and the often withered appearance of aged skin.

Studies of cutaneous perfusion vary, but the tendency is toward decreased capillary circulation in aged skin, especially in photoaged skin. Adaptation to temperature changes is slower in aged skin. These parameters correlate well with clinically apparent alterations in thermoregulation and wound healing in aged skin.

## REFERENCES

1. Rogers J, Harding C, Mayo A, et al. Stratum corneum lipids: the effects of aging and the seasons. *Arch Dermatol Res* 1996; 288:765–770.
2. Saint Leger D, Francois AM, Leveque JL, et al. Age-associated changes in the stratum corneum lipids and their relation to dryness. *Dermatologica* 1988; 177:159–164.
3. Cua AB, Wilhelm KP, Maibach HI. Skin surface lipid and skin friction. Relation to age, sex, and anatomical region. *Skin Pharmacol* 1995; 8:246–251.
4. Ghadially R, Brown BE, Swqueira-Martin SM, et al. The aged epidermal permeability barrier. Structural, functional, and lipid biochemical abnormalities in humans and a senescent murine model. *J Clin Invest* 1995; 95(5):2281–2290.
5. Schreiner V, Gooris G, Pfeiffer S, et al. Barrier characteristics of different human skin types investigated with x-ray diffraction, lipid analysis, and electron microscopy imaging. *J Invest Dermatol* 2000; 114(4):654–660.
6. Roskos KV The Effect of Skin Aging on the Percutaneous Penetration of Chemicals Through Human Skin. Dissertation, San Francisco, CA: University of California.
7. Harris IR, Farrell AM, Grunfeld C, et al. Permeability barrier disruption coordinately regulates mRNA levels for key enzymes of cholesterol, fatty acid, and ceramide synthesis in the epidermis. *J Invest Dermatol* 1997; 109(6):783–787.
8. Ghadially R, Brown BE, Hanley K, et al. Decreased epidermal lipid synthesis accounts for altered barrier function in aged mice. *J Invest Dermatol* 1996; 106(5):1064–1069.
9. Nielsen JB, Nielsen F, Sorensen JA. Defense against dermal exposures is only skin deep: significantly increased penetration through slightly damaged skin. *Arch Dermatol Res* 2007; 299(9):423–431; [Epub September 20, 2007].
10. Feingold KR. The regulation of epidermal lipid synthesis by permeability barrier requirements. *Crit Rev Ther Drug Carrier Syst* 1991; 8(3):193–210.



11. Feingold KR. The regulation and role of epidermal lipid synthesis. *Adv Lipid Res* 1991; 24:57-82.
12. Zettersten EM, Ghadially R, Feingold KR, et al. Optimal ratios of topical stratum corneum lipids improve barrier recovery in chronologically aged skin. *J Amer Acad Dermatol* 1997; 37(3 pt 1):403-408.
13. Meidan VM, Roper CS. Inter- and intra-individual variability in human skin barrier function: a large scale retrospective study. *Toxicol In Vitro* 2008; 22(4):1062-1069.
14. Choi EH, Man MQ, Xu P, et al. Stratum corneum acidification is impaired in moderately aged human and murine skin. *J Invest Dermatol* 2007; 127(12):2847-2856.
15. Rippke F, Schreiner V, Doering T, et al. Stratum corneum pH in atopic dermatitis: impact on skin barrier function and colonization with staphylococcus aureus. *Am J Clin Dermatol* 2004; 5(4):217-223.
16. Fluhr JW, Pfisterer S, Gloor M. Direct comparison of skin physiology in children and adults with bioengineering methods. *Pediatric Dermatol* 2000; 17(6):436-439.
17. Diktein S, Hartzshtark A, Bercovici P. The dependence of low pressure indentation, slackness, and surface pH on age in forehead skin of women. *J Soc Cosmet Chem* 1984; 35:221-228.
18. Shoen A. The Skin Surface pH as a Function of Age. M Pharm. Thesis, Hebrew University, 1982.
19. Wilhelm KP, Cua AB, Maibach HI. Skin aging: effect on trans-epidermal water loss, stratum corneum hydration, skin surface pH, and casual sebum content. *Arch Dermatol* 1991; 127:1806-1809.
20. Escoffier C, de Rigal J, Rochefort A, et al. Age-related mechanical properties of human skin: an in vivo study. *J Invest Dermatol* 1989; 93(3):353-357.
21. Dupuis D, Rougier A, Lotte C, et al. In vivo relationship between percutaneous absorption and transepidermal water loss according to anatomic site in man. *J Soc Cosm Chem* 1986; 37:351-357.
22. Leveque JL. Measurement of transepidermal water loss. In: LeVeque JL, ed. *Cutaneous Investigation in Health and Disease. Noninvasive Methods and Instrumentation*. New York: Marcel Dekker, Inc., 1989:135-152.
23. Baker H. Deperdition d'eau par voie trans-epidermique. *Ann Dermatol Syphiligr* 1971; 98:1806-1809.
24. Elsner P, Wilhelm D, Maibach HI. Sodium lauryl sulfate induced irritant contact dermatitis in vulvar forearm skin of premenopausal and postmenopausal women. *J Am Acad Dermatol* 1990; 23:648-652.
25. Grice KA, Bettley FR. Skin water loss and accidental hypothermia in psoriasis, ichthyosis, and erythrodermia. *Br Med J* 1967; 4:195-201.
26. Jemec G, Agner T, Serup J. Transonychia water loss. Relation to sex, age, and nailplate thickness. *Br J Dermatol* 1989; 121:443-446.
27. Tagami H. Aging and the hydration state of the skin. In: Kligman AM, Takase Y, eds. *Cutaneous Aging*. Tokyo: University of Tokyo Press, 1988: 99-109.
28. Roskos KV, Guy RH. Assessment of skin barrier function using transepidermal water loss: effect of age. *Pharm Res* 1989; 6(11): 949-953.
29. Giusti F, Martella A, Bertoni L, et al. Skin barrier, hydration, and pH of the skin of infants under 2 years of age. *Pediatr Dermatol* 2001; 18(2):93-96.
30. Tupker RA, Coenraads PJ, Pinnagoda J, et al. Baseline transepidermal water loss (TEWL) as a prediction of susceptibility to sodium lauryl sulphate. *Contact Dermatitis* 1989; 20:265-269.
31. Rougier A, Lotte C, Corcuff P, et al. Relationship between skin permeability and corneocyte size according to anatomic site, age, and sex in man. *J Soc Cosmet Chem* 1989; 39:15-26.
32. Aisen E, Shafran A, Gilhar A. Sebum and water content in the skin of aged immobilized patients. *Acta Derm Venereol* 1997; 77:142-143.
33. Yosipovitch G, Maayan-Metzker A, Merlob P, et al. Skin barrier properties in different body areas in neonates. *Pediatrics* 2000; 106:105-108.
34. Cua, AB, Wilhelm KP, Maibach HI. Cutaneous sodium lauryl sulfate irritation potential: age and regional variability. *Br J Dermatol* 1990; 123:607-613.
35. Potts RO, Buras EM. In vivo changes in the dynamic viscosity of human stratum corneum as a function of age and ambient moisture. *J Soc Cosmet Chem* 1985; 36:169-176.
36. Richard S, de Rigal J, de Lacharriere O, et al. Noninvasive measurement of the effect of lifetime exposure to the sun on the aged skin. *Photodermatol Photoimmunol Photomed* 1994; 10:164-169.
37. Pinnagoda J, Tupker RA, Agner T, et al. Guidelines for transepidermal water loss measurement. A report from the Standardization Group of the European Society of Contact Dermatitis. *Contact Dermatitis* 1990; 22:164-178.
38. Tagami H. Functional characteristics of stratum corneum in photoaged skin in comparison with those found in intrinsic aging. *Arch Dermatol Res* 2008; 300(suppl 1):S1-S6.
39. Tagami H. Location-related differences in structure and function of stratum corneum with special emphasis on those of the facial skin. *Int J Cosmet Sci* 2008; 30(6):413-434.
40. Shuster S, Black M, McVitie E. The influence of age and sex on skin thickness, skin collagen, and density. *Br J Dermatol* 1975; 93:639.
41. Gniadecka M, Nielsen OF, Wessel S, et al. Water and protein structure in photoaged and chronically aged skin. *J Invest Dermatol* 1998; 11:1129-1133.
42. Lovell CR, Smolenski KA, Duance VC, et al. Type I and III collagen content and fibre distribution in normal human skin during aging. *Br J Dermatol* 1987; 117:419-428.
43. Fisher GJ, Datta SC, Talwar HS, et al. The molecular basis of sun-induced premature skin ageing and retinoid antagonism. *Nature* 1996; 379:335-338.
44. Fisher GJ, Wang ZQ, Datta SC, et al. Pathophysiology of premature skin aging induced by ultraviolet light. *N Engl J Med* 1997; 337:1419-1428.
45. Varani J, Warner RL, Gharaee-Kermani M, et al. Vitamin A antagonizes decreased cell growth and elevated collagen-degrading matrix metalloproteinases and simulates collagen accumulation in naturally aged human skin. *J Invest Dermatol* 2000; 114:480-486.
46. Varani J, Dame MK, Rittie L, et al. Decreased collagen production in chronologically aged skin: roles of age-dependent alteration in fibroblast function and defective mechanical stimulation. *Am J Pathol* 2006; 168(6):1861-1868.
47. Sell DR, Strauch CM, Shen W, et al. 2-aminoadipic acid is a marker of protein carbonyl oxidation in the aging human skin: effects of diabetes, renal failure, and sepsis. *Biochem J* 2007; 404(2):269-277.
48. Uitto J. Connective tissue biochemistry of the aging dermis. *Clin Geriatric Med* 1989; 5:127-147.
49. Vitellaro-Zuccarello L, Garbelli R, Rossi VD. Immunocytochemical localization of collagen types I, II, IV, and fibronectin in the human dermis: modifications with aging. *Cell Tissue Res* 1992; 268:505-511.
50. Lavker RM, Zheng P, Dong G. Aged skin: a study by light, transmission electron microscopy, and scanning electron microscopy. *J Invest Dermatol* 1987; 88:44s-53s.
51. Sardy M. Role of matrix metalloproteases in skin ageing. *Connect Tissue Res* 2009; 50(2):132-138.
52. Imokawa G. Recent advances in characterizing biological mechanisms underlying UV-induced wrinkles: a pivotal role of fibroblast-derived elastase. *Arch Dermatol Res* 2008; 300(suppl 1):S7-S20.
53. Inui M, Ooie M, Fujii K, et al. Mechanisms of inhibitory effects of Co-enzyme Q10 on UVB-induced wrinkle formation in vitro and in vivo. *Biofactors* 2008; 32(1-4):237-243.
54. Yaar M, Gilchrist BA. Photoageing: mechanism, prevention and therapy. *Br J Dermatol* 2007; 157:874-887.
55. Callaghan TM, Wilhelm KP. A review of ageing and an examination of clinical methods in the assessment of ageing skin, Part 1. *Int J Cosmet Sci* 2008; 30(5):313-322.
56. Jacobson T, Yuksel Y, Geesin JC, et al. Effects of aging and xerosis on the amino acid composition of human skin. *J Invest Dermatol* 1990; 95:296-300.
57. Robert C, Lesty C, Robert AM. Ageing of the skin: study of elastic fiber network modifications by computerized image analysis. *Gerontology* 1988; 34:91-96.

58. Lee HC, Wei YH. Oxidative stress, mitochondrial DNA mutation, and apoptosis in aging. *Exp Biol Med* (Maywood) 2007; 232:592–606.
59. Powell JT, Vine N, Crossman M. On the accumulation of D-aspartate in elastin and other proteins of the ageing aorta. *Atherosclerosis* 1992; 97:201–208.
60. Ritz-Timme S, Laumier I, Collins MJ. Aspartic acid racemization—evidence for marked longevity of elastin in human skin. *Br J Dermatol* 2003; 149:951–959.
61. Ritz-Timme S, Collins MJ. Racemization of aspartic acid in human proteins. *Age Res Rev* 2002; 1:43–59.
62. Bernstein EF, Chen YQ, Tamai K, et al. Enhanced elastin and fibrillin gene expression in chronically photodamaged skin. *J Invest Dermatol* 1994; 103:182–186.
63. Seite S, Zucchi H, Septier D, et al. Elastin changes during chronological and photo-ageing: the important role of lysozyme. *J Eur Acad Dermatol Venereol* 2006; 20(8):980–987.
64. Gniadecka M, Nielsen OF, Christensen DH, et al. Structure of water, proteins, and lipids in intact human skin, hair, and nail. *J Invest Dermatol* 1998; 110:393–398.
65. Sander CS, Sercu S, Ziemer M, et al. Expression of extracellular matrix protein 1 in human skin is decreased by age and increased upon ultraviolet exposure. *Br J Dermatol* 2006; 154(2):218–224.
66. Bernstein EF, Underhill CB, Hahn PJ, et al. Chronic sun exposure alters both the content and distribution of dermal glycosaminoglycans. *Br J Dermatol* 1996; 135:255–262.
67. Takahashi Y, Ishikawa O, Okada Y, et al. Disaccharide analysis of human skin glycosaminoglycans in sun-exposed and sun-protected skin of aged people. *J Dermatol Sci* 1996; 11(2):129–133.
68. Lochner K, Gaemlich A, Sudel KM, et al. Expression of decorin and collagens I and III in different layers of human skin in vivo: a laser capture microdissection study. *Biogerontology* 2007; 8(3):269–282.
69. Wright AC, Bohning DE, Pecheny AP, et al. Magnetic resonance chemical shift microimaging of aging human skin in initial findings. *Skin Res Technol* 1998; 4(2):55–62.
70. Tolino MA, Wilkin JK. Aging and cutaneous vascular thermoregulation responses. *J Invest Dermatol* 1988; 90(4):613.
71. Kelly RL, Pearse R, Bull R, et al. The effects of aging on cutaneous microvasculature. *J Am Acad Dermatol* 1995; 33:749–756.
72. Chung JH, Yano K, Lee MK, et al. Differential effects of photoaging vs. intrinsic aging on the vascularization of human skin. *Arch Dermatol* 2002; 138:1437–1442.
73. Leveque JL, Corcuff P, de Rigo J, et al. In vivo studies of the evolution of physical properties of the human skin with age. *Int J Dermatol* 1984; 23(5):322–329.
74. Ishihara M, Itoh M, Ohsawa K, et al. Blood flow. In: Kligman AM, Takase Y, eds. *Cutaneous Aging*. Tokyo: University of Tokyo Press, 1988:167–181.
75. Thompson-Torgerson CS, Holowatz LA, Kenney WL. Altered mechanisms of thermoregulatory vasoconstriction in aged human skin. *Exerc Sport Sci Rev* 2008; 36(3):122–127.
76. Chung JH, Eun HC. Angiogenesis in skin aging and photoaging. *J Dermatol* 2007; 34(9):593–600.
77. Pittman J. Effect of aging on wound healing: current concepts. *J Wound Ostomy Continence Nurs* 2007; 34(4):412–415.
78. Ashcroft GS, Horan MA, Ferguson MW. The effects of ageing on cutaneous wound healing in mammals. *J Anat* 1995; 187(pt 1):1–26.
79. Falanga V. *Cutaneous Wound Healing*. London: Martin Dunitz Ltd., 2001.
80. Kligman AM. Perspectives and problems in cutaneous gerontology. *J Invest Dermatol* 1979; 73(1):39–46.

# Climatic influence on cosmetic skin parameters

Mathias Rohr and Andreas Schrader

## INTRODUCTION

Beside a good compatibility, which should be a matter of course for cosmetic products, the physiologic effectiveness, in particular moisture and smoothing effects on the skin, is the main interest for cosmetic products. Techniques such as fast optical in vivo topometry of human skin (FOITS) (1,2) and corneometry are used to investigate their effectiveness. A high degree of standardization is required to quantify the effects of cosmetics. To obtain reproducible and statistically significant results, experimental conditions, such as a test panel controlled climatic conditions and a test design including a positive and a negative standard, are the basic starting tools. Nevertheless, as the following discussion will show, it is not only the normal standardization procedures, such as acclimatization of volunteers in special air-conditioned laboratories, which have to be taken into consideration when interpreting objective and subjective cosmetic parameters, but also the effect of the actual climate during the application phase and especially during the days of measurement. The influence of the indoor climate in the laboratory as well as the outdoor climate will be analyzed. What will happen to the level of skin moisture during the preconditioning phase or what will happen at different seasons of the year? Will it be influenced by the level of relative room humidity and/or the actual climate conditions? Will the influence vary for different kinds of product? Will the influence on skin moisture and skin structure be comparable? Will the influence change for different types of volunteer? What is the best time for preconditioning? Could the regeneration of the stratum corneum be influenced by the climate? Will effects felt subjectively (washing the bend of the elbow) be equally dependent on climatic conditions as objectively rated parameters?

A summary of individual results and averages of thousands of volunteers will be given. Both a positive standard (in the sense of increasing moisture and smoothness) and a negative standard (in the sense of increasing dehydration, roughness or side effects) are used to present the effect of climatic conditions on skin physiology tests.

## MATERIALS AND METHODS

### Climatic Data

To be able to correlate climate data with skin physiology parameters, the relative humidity and outside temperature are measured continuously at a station by a computer (CAN system, Lufft Company, Fellbach, Germany). Capturing the data by computer ensures that the climate is recorded day and night. Let us take climatic changes in Holzminden (longitude 9.27 east and latitude 51.49 north; Middle Germany) over a year as an example. As Figure 3.1 shows, temperature fluctuates between values of about  $-10$  and  $25^{\circ}\text{C}$  in a year. Relative humidity is about 50% in summer and 90% in winter.

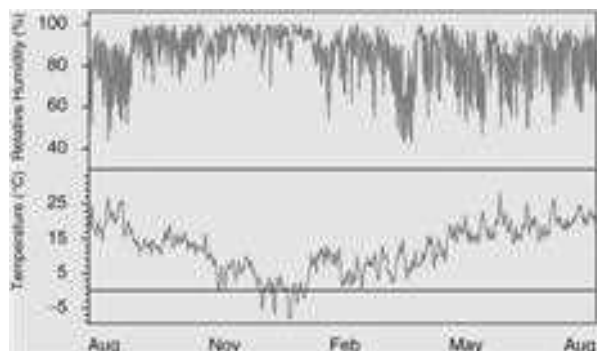
## Positive and Negative Standards

Tests have been carried out with the same products repeatedly over a period of several years, and these will serve to demonstrate the effect of climatic conditions on skin physiology. The positive standard is a well-accepted former brand product that is currently unavailable on the European market. However, we have been making it at a constant quality level for years using the known formulation. This product, referred to hereafter as "standard L" (Table 3.1), is tolerated very well by the skin and demonstrates a moisture-retaining and skin-smoothing effect that can be easily classified in terms of physiologic effectiveness. This makes it an ideal standard, because other products can be classified as better or worse with respect to their effectiveness. Another aspect of demonstrating the effectiveness of products on skin physiology relates to negative effects that, for instance, can be induced by aggressive surfactants. Here, too, we have been using the same standard product for years. This is sodium dodecyl sulfate (SDS), which is referred to as the "negative standard" from now on.

## Laser Profilometry

The laser profilometry technique is used to investigate the antiwrinkle effect. Skin replicas are taken from the test areas on the volar forearms by means of a white pigmented silicone substance (two components, Optosil<sup>®</sup>, Bayer, Inc., Germany), before the first application and 12 hours after the last application. A round impression having a diameter of 18 mm is made using a label especially designed for this purpose. While the impressions are being made the volunteers are seated on chairs with adjustable armrests so that the angle between the upper arm and the forearm can be adjusted to  $90^{\circ}$ . Fixing the forearms in this way ensures that no factitious smoothing or roughening effects, due to stretching of the arms when the impressions are taken after application, are evaluated and included in the documentation.

An automated laser scanner with an optical autofocus sensor is used for contactless scanning of the skin replicas (UBM, optical measuring system Microfocus, UBM RC14, Karlsruhe, Germany) (3). The measuring range of the laser scanner is  $\pm 500\ \mu\text{m}$  at a resolution less than 0.01% of the measuring range. The measuring spot (focus of the laser diode) has a diameter of about  $1\ \mu\text{m}$ . The z resolution is increased to  $\pm 25\ \text{mm}$  by an additional shift of the z-axis if necessary. The resolution in the x- and y-directions is identical to be independent of any predominant direction of wrinkles. The skin replica taken from the volar forearm of a volunteer is scanned over an area of  $8\ \text{mm} \times 8\ \text{mm}$  in the x- and y-directions at a resolution of 25 points/mm. Thus 40,000 individual measurements are available, permitting an exact three-dimensional reconstruction of the skin surface (3,4).



**Figure 3.1** Climatic outdoor conditions at Holzminden, Germany, from August 2001 to 2002.

**Table 3.1** Declaration of Positive “Standard L” According to the International Nomenclature of Cosmetic Ingredients

#### Ingredients

Water  
Liquid paraffin  
Caprylic/capric triglyceride  
Hydrogenated coco-glycerides  
Glycerine  
Myristyl alcohol  
Isohexadecane  
Glyceryl stearate  
Cetyl alcohol  
Proprietary composition  
4-Methylbenzylidene camphor  
Tocopheryl acetate  
Butyl methoxydibenzoylmethane  
*Aloe barbadensis*  
Isopropyl myristate  
Methylparaben  
Polyaminopropyl biguanide  
Bisabolol  
Soluble collagen  
Simethicone  
Sodium hydroxide  
Ethylenediaminetetraacetic acid

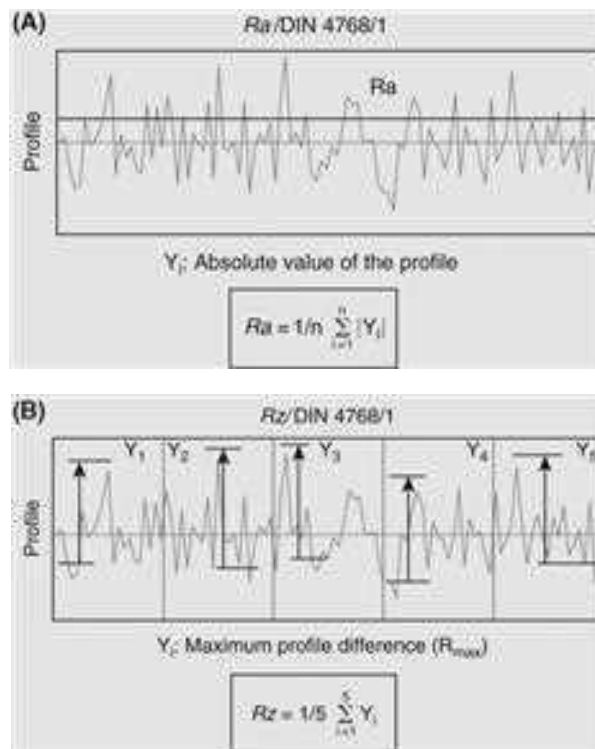
#### **Ra** Parameter

The Deutsche Industrie Norm (DIN) parameter  $Ra$  represents the mean roughness index according to DIN 4768.  $Ra$  indicates the arithmetic mean of the absolute values of the skin profile's deviations from the center line over the total distance.

If the overall structure of the profile remains unchanged ( $Rz$  constant) but the fine structure of the profile changes, then the  $Ra$  parameter will indicate smoothing or roughening by a reduced or increased value, respectively (5,6).

#### **Rz** Parameter

The  $Rz$  parameter represents a mean peak-to-valley height according to DIN 4768/1. If, in the two-dimensional case, a profile line is divided into five equal parts and the  $R_{max}$  parameter is calculated for each part,  $Rz$  will be the arithmetic mean of these five individual values. The  $Rz$  parameter will



**Figure 3.2** Definition of DIN parameters  $Ra$  (A) and  $Rz$  (B) according to DIN 4768/1.

indicate roughening of the skin profile by a significantly increased value if the profile is changed by the influence of a product (Fig. 3.2).

#### **FAST OPTICAL IN VIVO TOPOMETRY OF HUMAN SKIN**

After a successful validation phase, the first publication of the new FOITS technology can be found in 1997 (1). In comparison to the replica driven technique during the last decade, the touch-free technique of *fringe projection* became state of the art to investigate skin surface (2,7–9). Because of many technical advancements (as, for example, improved camera resolution, the use of blue LED lighting systems, or LASER-supported and computer-optimized overlaying procedures), an easy-to-operate system could be realized during the last years. As scientific interest on the mechanisms of wrinkle evaluation is always been pushed, the technical developments led to a tool of high scientific standard (10–13).

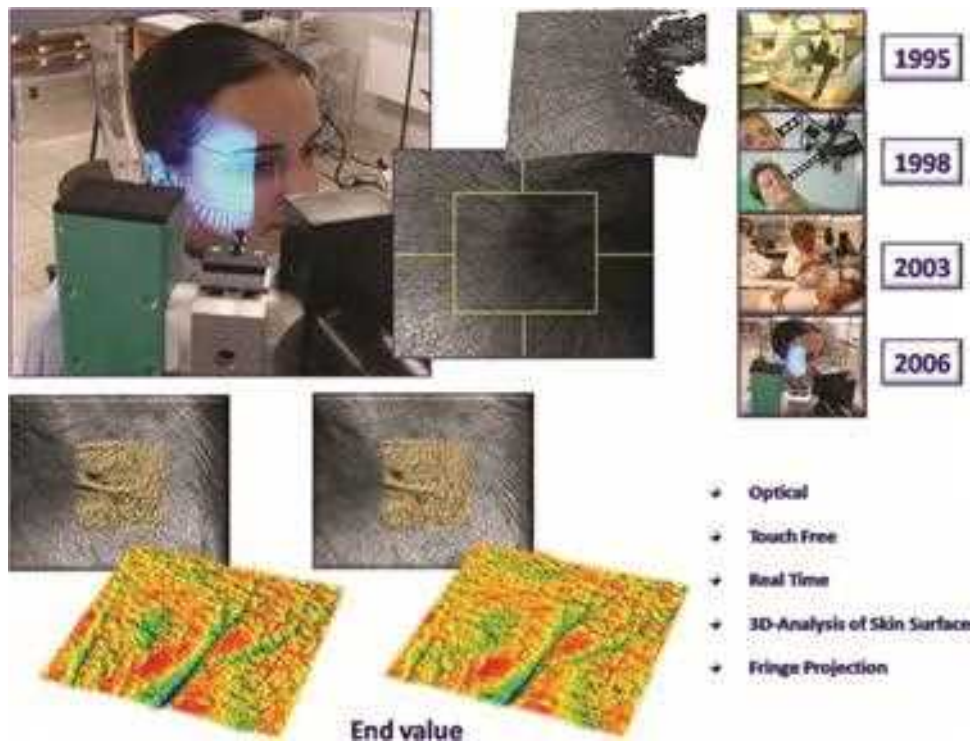
FOITS is a touch-free optical technique with a history of more than a decade to investigate skin surface structures in a direct three-dimensional measurement by fringe projection (14). The fringe-projection technique used is a combination of gray-code and phase-shift technique (5). In less than a few hundred milliseconds, the absolute space coordinates are measured of all object points in the selected image area with great exactness. The FOITS measurement system consists of a projection unit and a CCD camera. Both are fixed under the triangulation angle. Concerning the gray-code method, grids with a rectangular brightness distribution by different numbers of lines are projected. The

number of lines is doubled at each new projection. This gives a clearly defined hierarchy of lines for each image point. Regarding the phase-shift technique, only one grid with a sinus-like intensity distribution is projected several times with different phase positions. The FOITS technique is able to realize a depth sharpness area of  $\pm 10$  mm on an inspection area of 30 mm  $\times$  40 mm. The resolution in the vertical z-direction with 0.2% of the measured area leads to an effective resolution of 4  $\mu$ m in z-direction. A CCD camera with a horizontal and vertical resolution in x- and y-directions of about 30  $\mu$ m is used. It has to be pointed out that the resolution in z-direction is not limited by

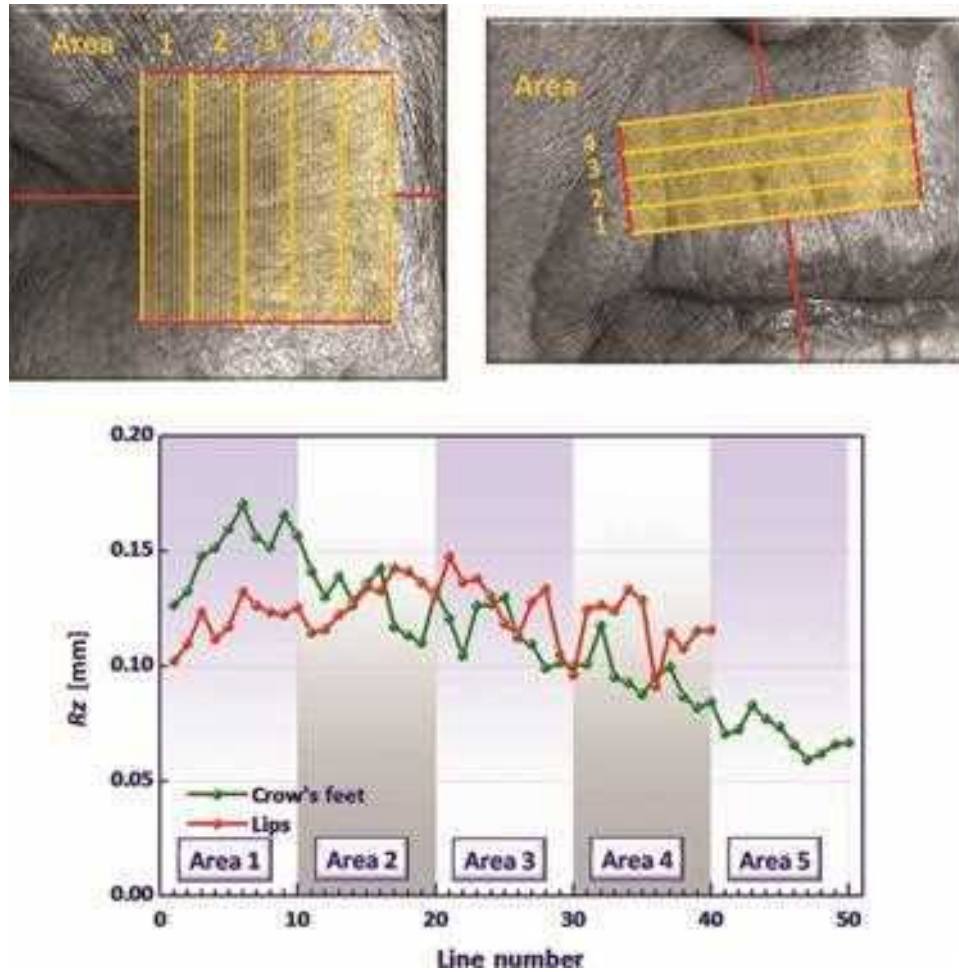
256 gray steps of the CCD camera. The high resolution in the vertical direction is achieved by the analysis of the intensity and phase displacement of the projected grids. The surface structure of the analyzed area causes a deviation of the intensity and phase information of the projected grid structures from the theoretical model structure of a plane surface. With corresponding mathematical algorithms, the absolute three-dimensional coordinates of the inspected area can be calculated of these deviations. A synopsis of the most important experimental side parameters is shown in Table 3.2, starting from the beginning of first experiments up to these days (Fig. 3.3).

**Table 3.2** Synopsis of the Technical Side Parameters of FOITS from the Beginning to Today

FOITS	1995	1998	2003	2006
Technique	Gray-code and phase-shift technique			
	Contact free direct skin measurement in vivo			
	Halogen light		Blue LED technique	
Superimposition	Mechanically aided by online overlay procedure		LASER aided mechanically	Software aided on top of all
Measurement area	Inner side of the forearm	Crow's-feet, under the eye, cheek, glabella, lips, nasolabial, décolleté, forearm, leg		
Area of inspection	875 mm <sup>2</sup> (25 mm $\times$ 35 mm)		1200 mm <sup>2</sup> (30 mm $\times$ 40 mm)	
Area of analysis	20 mm $\times$ 20 mm		20 mm $\times$ 20 mm (or as needed)	
Resolution x-direction	$\sim 40$ $\mu$ m		$\sim 30$ $\mu$ m	
y-direction	$\sim 40$ $\mu$ m		$\sim 30$ $\mu$ m	
z-direction	4 $\mu$ m		4 $\mu$ m	
Time to digitize the fine structure	$\sim 320$ msec		$\sim 260$ msec	



**Figure 3.3** Presentation of various FOITS system from 1995 to today; example of FOITS data presentation on an individual subject. 3-DIM data presentation of the crow's-feet area before and after four weeks of product application.



**Figure 3.4** Definition of subarea of analysis.  $R_z$  as a function of subarea lines of an individual example in the crow's-feet area and lip area.

Starting with analysis of the inner side of the forearm, the crow's-feet area became the area of most interest later on. Increasing the power of FOITS technique as described in Table 3.2, more and more areas of analysis could be investigated like cheek, glabella area, under the eye, nasolabial area, lips, or all over the body areas like décolleté and legs. The latest technique used combines the fastest data measurement with the best superimposition technique to guarantee a perfect comparison of baseline and end value data. Superimposition is realized in a combination of LASER-aided mechanical alignment of the subject in a first step and a software-driven rotation and shifting procedure of measured data/pictures to find the optimum of superimposition.

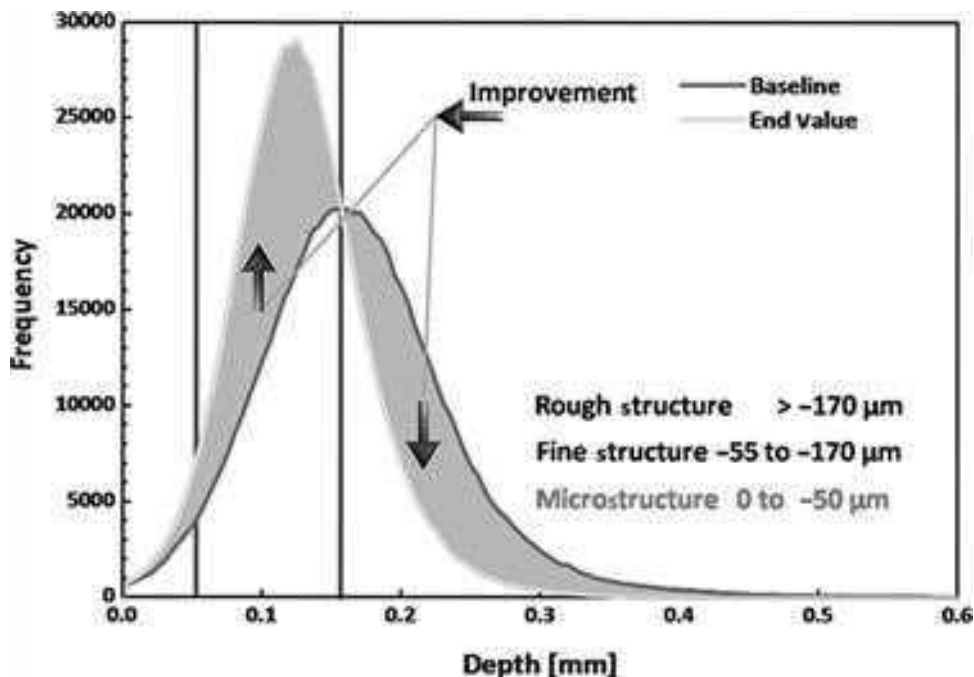
### Parameter of Analysis

Bringing into focus the periorbital wrinkle area (crow's-feet), the morphological structure of this test area has to be taken into account if wrinkles are investigated. Having this in mind, analysis is carried out perpendicular to the main wrinkle direction based on the  $R_z$  parameter (according to DIN 4668 (10)) or the frequency distribution of depth (FDD) analysis. Starting close to the eye, 50 separate lines with a distance of 400  $\mu\text{m}$  are analyzed. The resulting roughness is shown as a

function of line number (Fig. 3.4). Ten successive lines are averaged, resulting in five areas of evaluation. Separating the area of analysis into these five subareas (areas 1 to 5, see Fig. 3.4), the area close to the eye named area 1 represents the deepest structures while with area 5 smaller structures are quantified. An example of this analysis is given in Figure 3.3. In comparison, analysis of the lip area is shown. Because of the smaller test area at all only 4 areas are defined with 40 separate lines with a distance of 250  $\mu\text{m}$ . As shown by Figure 3.1, correlation of line number and  $R_z$  results in a more flat link for the lip area in comparison to the crow's-feet area.

To document the surface structure by a global parameter, the frequency distribution of all depths is used. The FDD is calculated in the range from  $-600 \mu\text{m}$  to  $600 \mu\text{m}$  (after polynomial correction) by using interval steps of 5  $\mu\text{m}$ . The defined evaluation area is equivalent to a surface of  $2 \text{ cm} \times 2 \text{ cm}$  and represents according to the technical resolution of the camera 640.000 single points. Therefore, a calculated FDD parameter is based on a rearrangement within these 640,000 values of depth.

Working with a distribution function the zero level has to be kept in mind carefully. Thus, the zero level of each volunteer is defined as the first plane representing a level of about 0.1% of all single values (about 600 counts). This plane is set as zero and



**Figure 3.5** Histogram of depth of a surface profile (crow's-feet area), classification of structural regions as well as visualization of smoothing effect/age effect-baseline: 65-year-old subject, end value: 15-year-old subject.

all further calculations are done with these resulting standardized values. From the surface structure, a frequency distribution of all depths is obtained as shown exemplarily in Figure 3.5 (red curve).

According to the selected zero level, a classification of depth is made as follows:

0 to 50 $\mu\text{m}$	→ microstructure	(about 5%)
55 to 170 $\mu\text{m}$	→ fine structure	(about 65%)
<170 $\mu\text{m}$	→ rough structure	(about 30%)

The given proportion will give a rough estimation of structure ranges found in the crow's-feet area of women with distinct wrinkles and Caucasian skin. Taking into account a product smoothing effect, the green FDD curve as shown in Figure 3.3 can be expected. Consequently, an improvement of skin structure is defined by a shift of maximum and a change of width of the distribution function. A reduction of rough structures can be expected, while for fine- and microstructures an increase is obtained in case of structural improvements.

### Corneometer

Water differs markedly from most substances as far as its dielectric constant is concerned. A quantitative proof of changes to the water content of the skin can thus be achieved by means of capacity measurements in a noninvasive manner (15,16).

A corneometer (Courage + Khazaka Co., Köln, Germany) is used to measure the water content (Table 3.3). A measuring capacitor reacts to the samples in the volume to be measured by

**Table 3.3** Summary of Experimental Conditions for the Various Skin Physiology Tests

Investigation brief description
Corneometer 20–30 volunteers
2–3 wk of application; twice a day
Baseline measurement on the forearm
Final value 12 hr after the last application
Statistical analysis of data
Corneometer kinetic frequent measurements up to 5 hr
Laser profilometry 30 volunteers
3 wk of application; twice a day
Silicone replica of the forearm (baseline)
Silicone replica 12 hr after the last application (final value)
Robot-controlled laser profilometry
Analysis of $R_a$ and $R_z$
FOITS frequent measurements up to 4 hr
No replica
Analysis of $R_a$ and $R_z$
Washing test on the bend of the elbow 20 volunteers
5 days of application
Twice a day, $2 \times 1$ minute of washing
Subjective rating of side effects in a direct comparison
Reddening/stinging/skin tautness/itchiness
Skin roughness/dull feeling/bad skin feeling
Statistical analysis of reaction points
DHA decoloring 20 volunteers, aged >50 years
Measurement of skin color by Chromameter (baseline)
Application of DHA to inner side of forearm
Application of test product twice a day for 18 days
Measurement of skin color every day
Analysis of decay curves

*Abbreviation:* DHA, dihydroxyacetone.

way of capacitance changes (depending on water content). Those capacitance changes registered by the measuring head capacitor are processed fully automatically by the equipment to form a digital measured value. There is no conductive (galvanic) connection between the object measured and the measuring equipment. Consequently, almost no electricity flows through the object measured. Properties such as ionic conductivity and polarization effects have no influence on the measurement result. The fact that the electronics adapt to the moisture circumstances almost without inertia means that the measuring process is very fast and that it is possible, to a considerable extent, to eliminate effects on the results caused by involuntary movements or moisture accumulation during the measuring process.

All tests mentioned in this discussion were carried out in an electronically controlled air-conditioned laboratory that ensures that room temperature and air humidity are kept constant. The volunteers were kept seated in this laboratory at 22°C ( $\pm 1$ ) and 60% or 50% ( $\pm 5\%$ ) relative humidity for 45 minutes before the test and during the complete standard test procedure.

To quantify the influence of this procedure of standardization, frequent measurements were carried out immediately after the volunteers arrived at the institute and for up to five hours. To show the basic influence of the indoor climate, no product application was performed during the time of the investigation. In a second series of measurements, five different brands and five different formulations with an increasing amount of glycerine (3–25%) as an active ingredient were investigated in a short time test design up to four hours after product application. To quantify the influence of the indoor climate on the product rating, the second test series was carried out twice. In a first run, the relative humidity was set at 60%; in a second run the relative humidity was reduced to 50%.

Transient individual side effects that may have an influence on the skin are standardized in this way. However, this procedure does not compensate for climatic conditions such as for winter or summer.

## Regeneration

Dihydroxyacetone (DHA) is a substance that is tolerated very well and is approved in the cosmetics industry as a suntan substance. It tans by means of the Maillard reaction, forming combinations with amino acids in the skin that do not wash off. The color disappears within approximately three weeks as a result of desquamation of the colored horny cells. The tan of the skin decreases accordingly.

For this investigation, the desquamation effect, and consequently the rate of regeneration, is measured in the laboratory color room by measuring the decoloring with a Minolta Chromameter CR 300 (L-a-b color room). The yellow value  $b$  differentiates best, and this is used to establish the color decay curves (17,18).

The region that is tested is again the volar forearm. Areas of 4 cm  $\times$  4 cm in the middle of the region of application are colored with DHA after a defined washing procedure to standardize the baseline conditions. In the coloring process, a special emulsion with 10% DHA is applied to the area to be tested. The amount applied is 6 mg/cm<sup>2</sup>. In addition, an adhesive bandage saturated with DHA emulsion is applied for 24 hours. Over the next 18 days, the volunteers continue to

use the products twice a day. The forearms are permitted to be washed only twice a day with warm water. Surfactants and abrasive cleansing agents are not allowed to be used. Measurements are taken directly before DHA coloring, and then every day over the next 18 days with the exception of weekends. For each time and area of measurement, three values are recorded at different places in the measurement area and averaged. The  $b$ -values of all 30 volunteers per product are averaged, and the standard deviations, percentage changes, and percentage differences standardized to the coloring are calculated. The color decay curves can be described under normal conditions with the following exponential function:

$$b = a_1 e^{-a_2 t} + a_3$$

Further statistical treatment is described in detail in Refs. 3 and 9.

## Washing Test on the Bend of the Elbow

To assess the skin tolerance, the cleansing effect, and the acceptance of surfactant products, we carry out the washing test on the bend of the elbow. In a practical test, the bend of the elbow is washed under intensive conditions. Twenty volunteers take part in this test. In each application, the bend of one elbow is lathered vigorously with the first sample and washed for two minutes by hand. After being rinsed with lukewarm water, this bend of the elbow is again lathered and washed for two minutes. This is followed by a period of drying also lasting two minutes. After the second rinsing with lukewarm water, the area in question is dabbed dry carefully with a towel, ensuring that there is no rubbing. The bend of the other elbow is treated in exactly the same way with the negative standard SDS (19,20).

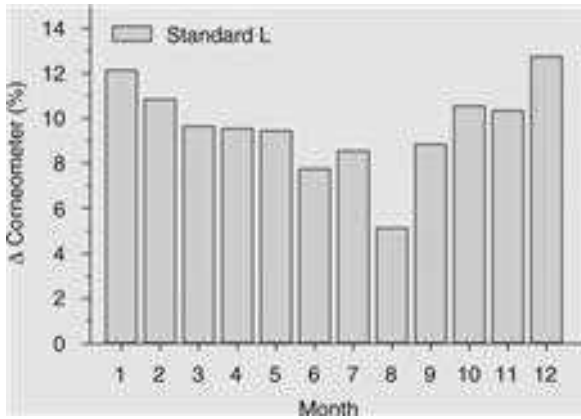
To determine any side effects induced by the test products, the volunteers are asked at the end of the test about any reactions they noticed directly after washing. The following parameters are ascertained: reddening, stinging, skin tautness, itchiness, skin roughness, dull feeling, and bad skin feeling. The ratings are given on the basis of a coded volunteer questionnaire.

## RESULTS AND DISCUSSION Outdoor Climate

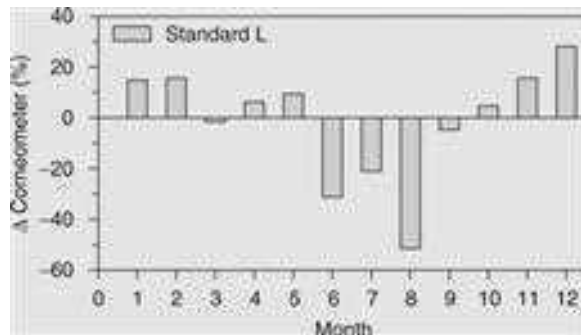
One of the major factors in cosmetic skin physiology is the moisture-retaining effect of a product. Figure 3.6 shows a summary of this for 1992–1995. The data have been summarized on a monthly basis in each case. Figure 3.6 shows the percentage increase in moisture that is induced by the positive standard L after correction for changes in the corresponding untreated area. The recorded averages are based on at least 100 volunteers a month.

Calculations led to an average moisture increase of approximately 12.7% for all data recorded. To make it easier to compare seasonal dependency of the achievable moisture increase, Figure 3.7 shows the difference from the overall average after the data have been standardized on the basis of the overall average. A change of 0% corresponds to the above-mentioned overall average of approximately 12.7% moisture increase. A bar in the positive direction thus shows an increase in moisture that is higher than the average, whereas a bar in the negative direction indicates a reduced level of effectiveness. Figure 3.7 shows that from November to February, there was

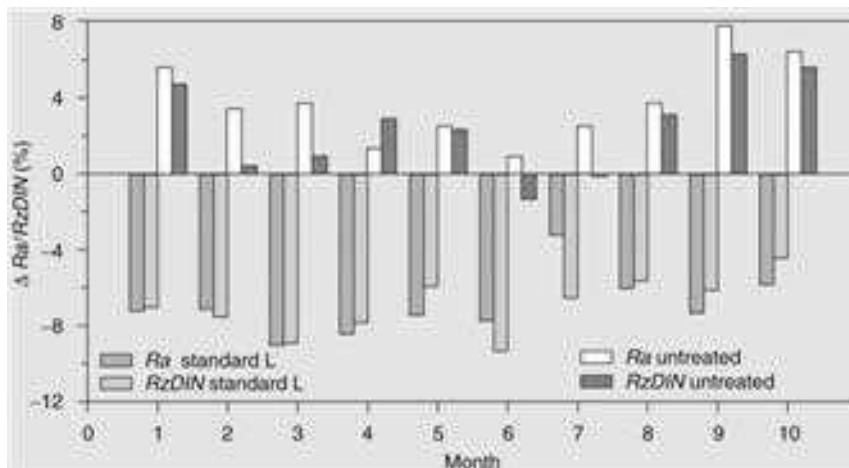




**Figure 3.6** Percentage increase in moisture, after correction for the untreated area, of positive standard L monthly summary (12 hours after last application, 4460 volunteers, 1992–1999).



**Figure 3.7** Standardized differences of moisture for the positive standard L after correction for the untreated area (12 hours after the last application, 3100 volunteers, 1992–1995).



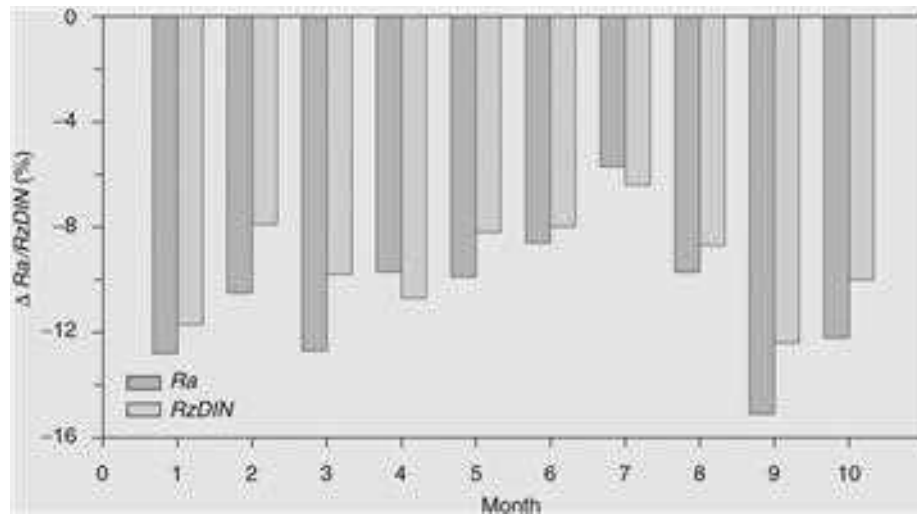
**Figure 3.8** Percentage of differences for the DIN parameters *Ra* and *Rz* for the positive standard L and the untreated area in a summary of laser profilometry data (1000 volunteers in general, 12 hours after the last application, 1994–1996).

about 15% above the average moisture increase, whereas in the summer months of June, July, and August, the level of effectiveness was approximately 50% below the average achievable moisture increase.

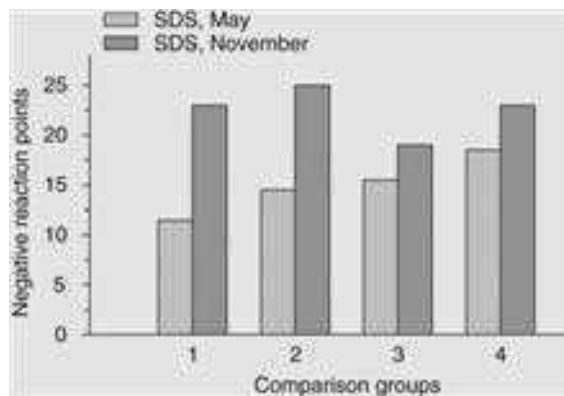
Figure 3.8 shows the relative change of the laser profilometry parameters *Ra* and *Rz* both for the positive standard L and for the untreated area in a way that is comparable to Figure 3.6. At this juncture, we must point out that the area referred to as “untreated” has not been treated with a cosmetic but has been subjected to a washing procedure to obtain better results, as described in the “Materials and Methods” section. Figure 3.8 clearly shows how important this prior treatment is. Whereas the *Ra* and *Rz* parameters for the positive standard fluctuate between  $-6\%$  and  $-8\%$  from January to October 1994 to 1996 without showing a definite trend, these parameters fall noticeably for the untreated area from January to August followed by a rise in September and October. After allowing for the untreated area, the profilometry tests result in the dependency that is shown in Figure 3.9A. Again, the positive standard L was found to be less effective on average in the summer months of June, July, and August than in the other months.

The data clearly show that the seasonal dependency was based both on the reduced positive effectiveness of standard L in the summer and on the reduced negative sensitivity of the untreated area (prior treatment with a surfactant of all areas tested). External climatic conditions thus have a distinct influence on the cosmetic effects that can be achieved. The basic level of the skin is increased in the summer months to such an extent that, first, skin moisture and smoothing can be increased further by cosmetics to only a limited degree and, second, that the deliberate use of substances that are detrimental to the skin also has a limited negative effect. This leads to an apparent reduction of cosmetic effectiveness.

In addition to these objective skin physiology parameters, subjective information gained from volunteers’ answers to questions indicates a comparable dependency on external climatic conditions. Figure 3.10 shows the total negative reaction points that volunteers gave for reddening, stinging, skin tension, itchiness, skin roughness, dull feeling, and bad skin feeling in the elbow washing test. The negative reaction points



**Figure 3.9** Differences of the DIN parameters *Ra* and *RzDIN* after correction for the untreated area in laser profilometry (12 hours after last application, 1994–1996).



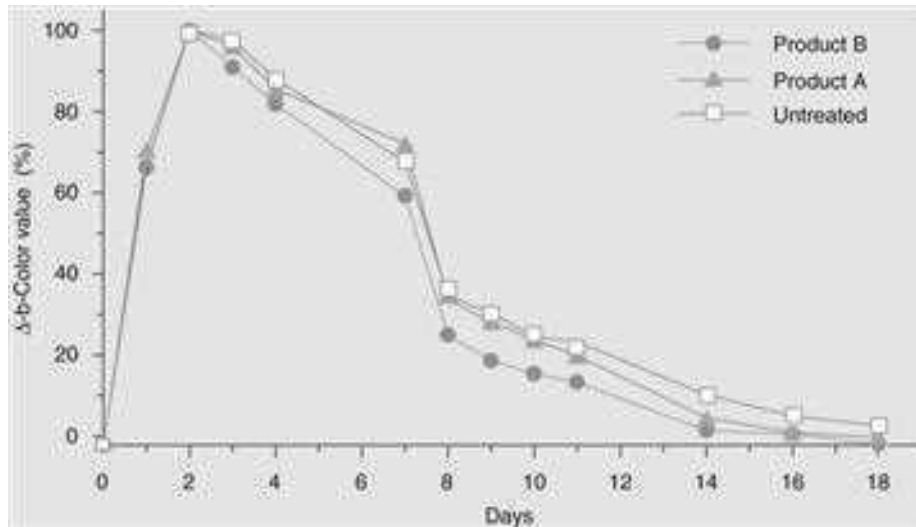
**Figure 3.10** Negative reaction points in a subjective rating system for four individual comparisons of the negative standard sodium dodecyl sulfate (SDS) to four different products in a washing test on the bend of the elbow (20 volunteers in each comparison).

for the negative standard fluctuated between 11 and 18 in May, depending on the comparative product. Since the comparative product is of crucial importance in rating effects subjectively, the same test setup was repeated in November with the same comparative products. Here, the average total negative reaction points for the comparative product SDS were distinctly higher in all four groups taking part in the test. Whereas the average for May was approximately 15 negative reaction points, this rose to approximately 23 reaction points in November under otherwise identical conditions as far as the volunteers' subjective feelings were concerned. These data, based on 80 volunteers, clearly show that it is

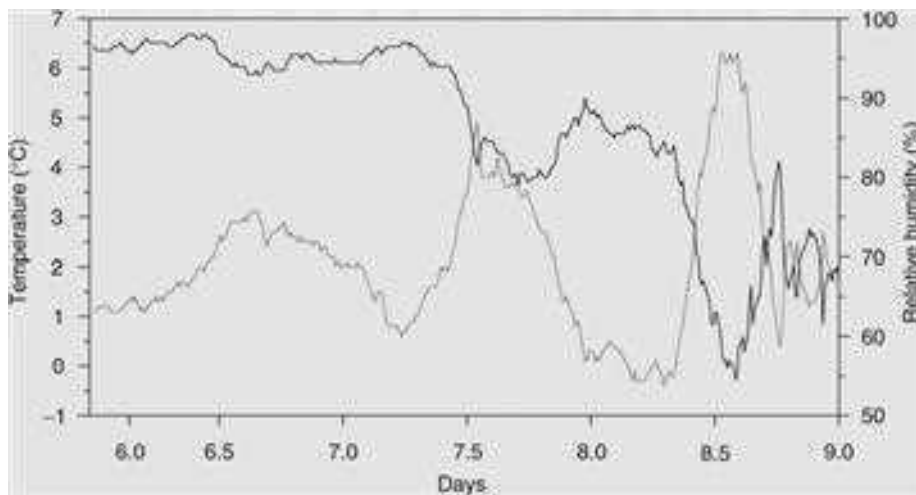
possible and necessary to correlate information derived from volunteers' subjective ratings with climatic conditions and to consider this along with the objectively demonstrable parameters for skin physiology.

Another example of how external climatic conditions make it almost impossible to evaluate the results of skin physiology investigations is given by the turnover of the stratum corneum on the basis of DHA decoloring tests. When the stratum corneum has been colored with DHA, it can generally be expected that there will be a constant exponential reduction of skin coloring of both the untreated area and the areas that have been treated with the test products (17). Figure 3.11 shows average curves that have been standardized to the maximum coloring, on the basis of 20 volunteers for two test products (A and B) containing  $\alpha$ -hydroxy acids and one untreated area. The observation period was 18 days. In contrast to theoretical expectations and preliminary experiments, this investigation revealed a fall in skin coloring from about 70% to about 30% on day 8. Both before and after this sudden change, the curve is in keeping with theoretical expectations. When all potential technical sources of error had been eliminated, the solution to this problem was found in the temperature and relative humidity data for the days of measurement, as shown in Figure 3.12. As the curves show, relative humidity fell from about 90% to about 60%, whereas the temperature rose from about 0 to 6°C over the same period of just a few hours, and then fell to 1°C after a short time. Since temperature/humidity fluctuations were far less extreme in the rest of the test period, it seems reasonable to suppose that the strong fluctuations of temperature and humidity correlate with the recorded inconsistency in the DHA color decay curves. This inconsistency induced by extreme climatic fluctuations made it necessary to repeat the test, because it was no longer possible to carry out an exponential analysis of the decay curves.

As the measured curve was constant before and after day 8 but higher humidity fluctuations accompanied by lower



**Figure 3.11** Exponential decay curves of the dihydroxyacetone (DHA) decoloring test standardized to the maximum coloring characterized by changing of the *b*-value of the L-a-b color room.



**Figure 3.12** Climatic data of temperature (grey) and relative humidity (black) from day 6 to day 8 during the dihydroxyacetone (DHA) investigation.

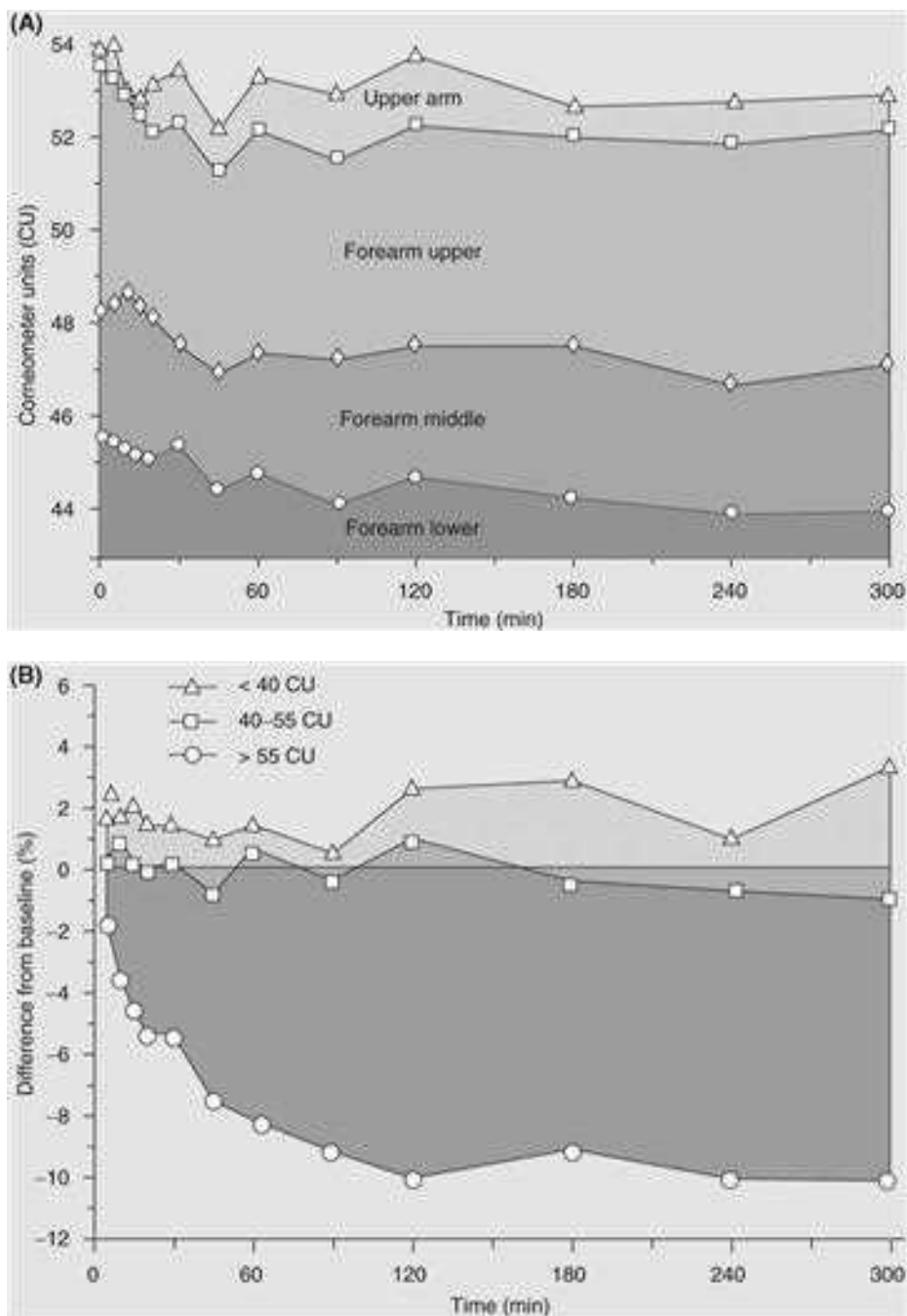
temperature fluctuations were recorded on day 7, it can be assumed that humidity is of greater importance in examining the regeneration of the stratum corneum and that the outside temperature plays only a subordinate part in the quality of this skin physiology investigation.

### Indoor Climate

Figure 3.13A presents the results of the “no product Corneometer kinetic” (i.e., without application of a product). The kinetic measurements were carried out on four different test areas

(forearm—lower, middle, and upper—and upper arm). In Figure 3.13B, the forearm data are summarized on the basis of the first measured value. The first group had starting values below 40 Corneometer Units (CU), the second group summarized the volunteers between 40 and 55 CU, and the third group was based on starting values above 55 CU.

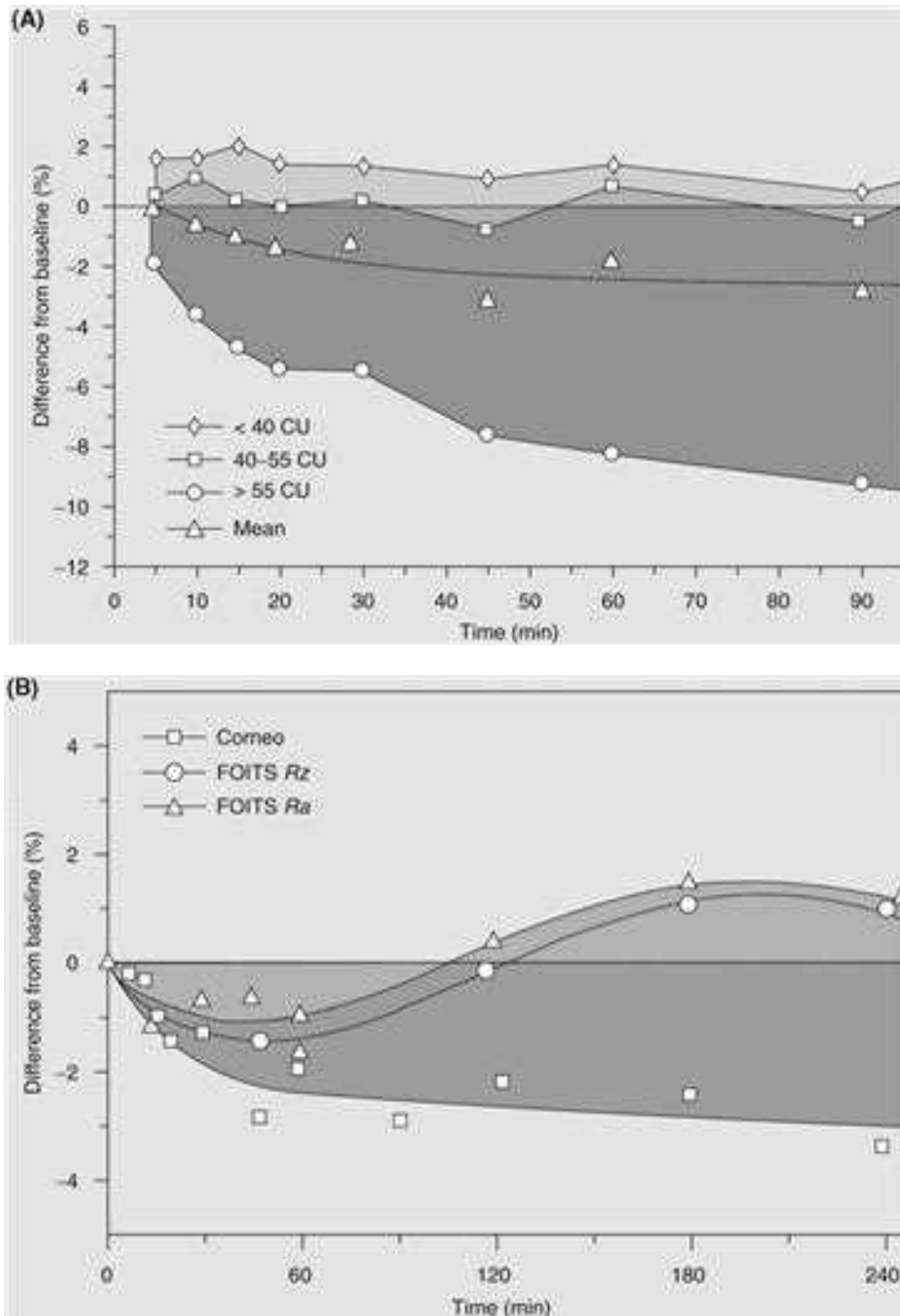
Analyzing the data of different test areas resulted in a decrease of about 2 CU for the upper forearm and a little less for the other test areas independent of the absolute level, which was different for each test site (lower forearm < middle forearm < upper forearm = upper arm). These data were



**Figure 3.13** (A) Kinetic Corneometer—data summarized for different test areas, without any product application ( $n = 120$ ). (B) Kinetic Corneometer—difference from baseline; data summarized for different volunteers, without any product application ( $n = 120$ ).

calculated without taking into account the individual skin type of the volunteers. Figure 3.13B reflects this, showing the individual starting conditions. As can be seen from the differences from baseline, the group with 40 to 55 CU did not show any changes above about 1% during five hours of investigation. The group below 40 CU showed a constant increase of approximately 2%, whereas for the group with

high starting values above 55 CU, a decrease of up to 10% was obtained. Independent of the test site the preconditioning phase seems to be most effective for a high skin moisture level at the beginning of the study. A dry skin might be less influenced by the indoor climate. The data to determine the optimal time of preconditioning to generate stable skin conditions are represented in Figure 3.14.

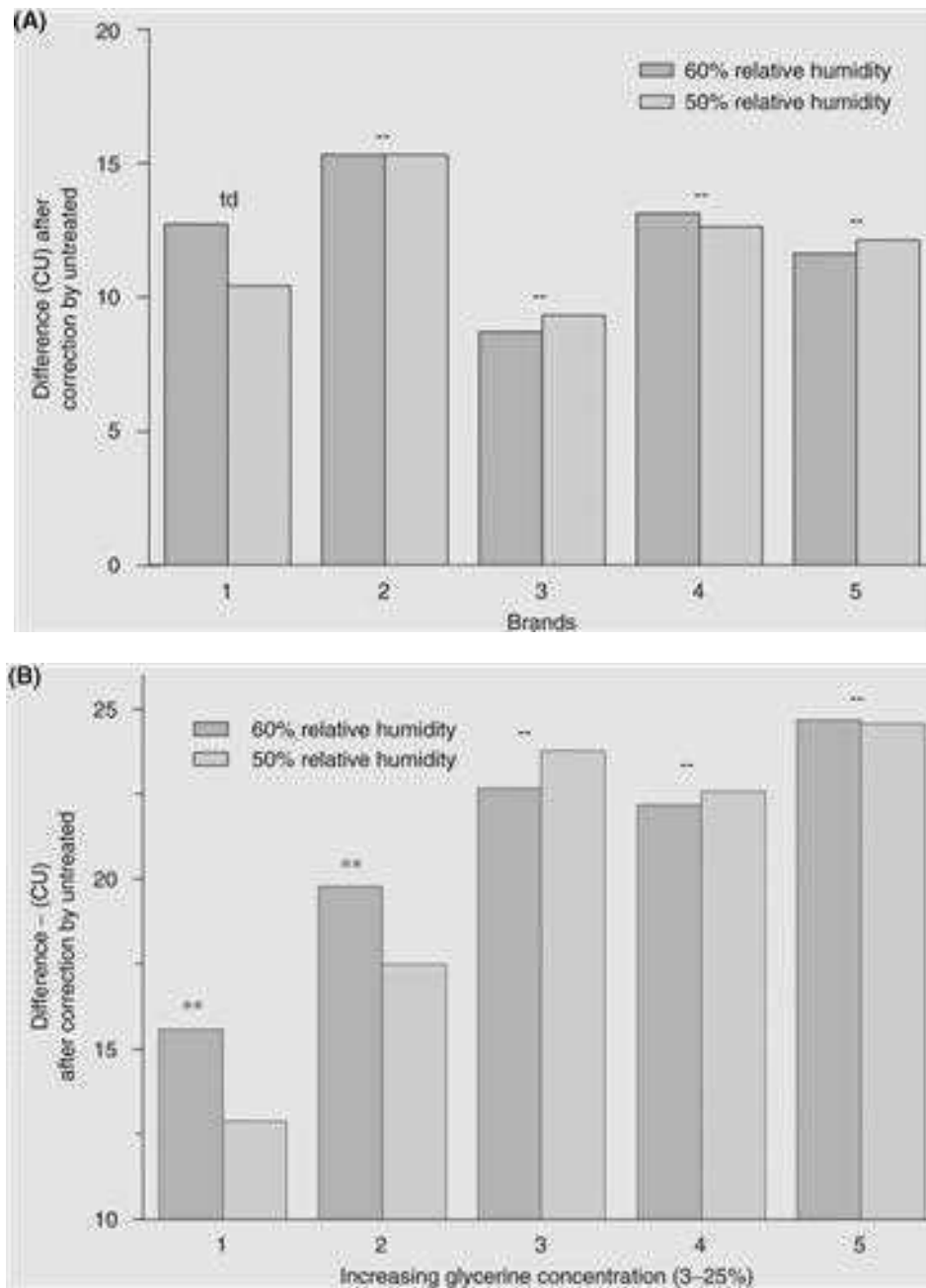


**Figure 3.14** (A) Kinetic Corneometer—difference from baseline; data summarized for different volunteers up to 90 minutes, without any product application ( $n = 120$ ). (B) Kinetic FOITS and Corneometer—difference from baseline mean overall up to 240 minutes, without any product application ( $n = 120/40$ ).

As shown in Figure 3.14A, the difference from baseline ( $-\Delta-$  curve: mean overall) became stabilized at 30 minutes and remained constant from 60 minutes on. Thus, 45 minutes of acclimatization seems to be the best choice—a time not too short for “moist” skin and not too long to reflect a reliable test design.

The data describing the skin surface are given in Figure 3.14B. No significant changes occurred during the

four-hour kinetic investigation. Differences between lower and upper forearm were comparable to the Corneometer measurements. Nevertheless, summing up the  $Rz$  and  $Ra$  values for up to four hours, no trend in the changes was observed. Consequently, the influence of the indoor climate seems to be of minor impact if compared to skin moisture. In any case, changes of the skin structure are obviously on a much slower



**Figure 3.15** (A) Corneometer for brands 1–5. Difference from baseline after correction by untreated. (B) Corneometer for increasing concentration of glycerine (bar 1, 3% increasing to bar 5, 25%). Difference from baseline after correction by untreated.

time scale if the producing event is as indirect as the indoor climate.

Changing the kinetic view to more static analysis, the data of five different brands are summarized in Figure 3.15. Figure 3.15A shows the difference between baseline and end value four hours after unique product application in absolute CU. The dark blue bars represent the data at an indoor climate of 60% relative humidity, whereas the light blue bars are obtained at 50% relative humidity.

With the exception of product no. 1, no difference occurred from changing the indoor humidity. For product no. 1, a tendency was calculated for the comparison of both measurements. Taking product no. 1 as a hint that an influence might be possible, a second run of five formulations with an increasing amount of glycerine was carried out under the same conditions. In this case, significant changes occurred for the first two low glycerine concentrations (concentration below saturation). At 50% relative humidity, the level of measured absolute units decreased

significantly. Thus, the selectivity became better if the relative humidity was reduced and the product contained hygroscopic active ingredients. The hygroscopic ingredient seems to pick up the air humidity like a sponge as long as it is in the upper stratum corneum. Nevertheless, the origin of moisture should be irrelevant for the skin, but in the case of ranking and differentiating products as fast as possible after the product application, it might be helpful to measure at 50% relative humidity.

## CONCLUSION

The data recorded, both from objective skin physiology parameters such as moisture and smoothness and from subjective factors in the elbow-washing test, clearly show that such tests are influenced considerably by climatic conditions. Differences, such as between summer and winter, cannot be compensated for by acclimatization in air-conditioned laboratories. Alongside standardized measurement conditions, it is therefore essential to record the quality of the test panel not only by including an untreated area but also by means of a positive or negative control. Only in this way is it possible to establish a classification system for test products that is not dependent on a particular season and allows the quality of cosmetic products to be rated objectively.

As demonstrated by the obtained results, the indoor climate also plays an important part in cosmetic efficacy testing. Beside the outdoor climate, which might have an effect on a long-term basis, the indoor climate (specially the time of preconditioning) is decisive for short-term and kinetic investigations. While the influence of the moisture level is strongly dependent on the starting value, the changes of the skin topometry seem to be not so marked. On the basis of the Corneometer kinetic data, 45 minutes of preconditioning appears to be an optimal compromise between effect, standardization, and costs. The laboratory conditions (relative humidity) may also be of great influence. Depending on the active ingredients (hygroscopic or not), a ranking of products might be of greater selectivity if a lower level of relative humidity is used.

All in all, the presented data underline the importance of a standardized procedure to investigate cosmetic effects on a statistical and reproducible level.

## REFERENCES

- Rohr M, Schrader K. Fast optical in vivo topometry of human skin (FOITS)—a comparison to LASER-Profilometry. 5th Congress of the International Society for Skin Imaging, Vienna, 1997.
- Rohr M, Schrader K. Fast optical in vivo topometry of human skin (FOITS). *SÖFW J* 1998; 124(2):52–59.
- Rohr M, Schrader K. Surfactant-induced skin roughness: quantitative analysis of the surface structure of the skin via automated non-touch laser scanning. *Eurocosmetics* 1994; 8:24–28.
- Hartung J. Statistik, Lehr- und Handbuch Der Angewandten Statistik. 9th ed. Munich, Oldenburg: Oldenbourg-Verlag, 1993.
- DIN 4768: Ermittlung der Rauheitskenngrößen Ra, RzDIN, Rmax mit elektrischen Tastschnittgeräten: Begriffe, Messbedingungen. Berlin: Beuth Verl, 1990.
- Stout J, Sullivan PJ, Dong WP, et al. The development of methods for characterization of roughness in three dimensions. Report EUR 15178 EN. Eur Community, 1993.
- Lagarde JM, Rouvrais C, Black D, et al. Skin topography measurement by interference fringe projection: a technical validation. *Skin Res Technol* 2001; 7:112–121.
- Jaspers S, Hoperman H, Sauermann G, et al. Rapid in vivo measurement of the topography of human skin by active image triangulation using a digital micro-mirror device. *Skin Res Technol* 1999; 5:196–207.
- Ferrag Y, Black D, Lagarde JM, et al. Use of 3-D imaging technique for non-invasive monitoring of the depth of experimentally induced wounds. *Skin Res Technol* 2007; 13:399–405.
- Rohr M, Schrader A. FOITS (Fast Optical in vivo Topometry of Human Skin)—a classical method in modern efficacy testing—a history of fringe-projection in cosmetic, *SOFW*, 2009.
- Nouveau-Richard S, Yang Z, Mac-Mary S, et al. Skin ageing: a comparison between Chinese and European populations—a pilot study. *J Dermatol Sci* 2005; 40(3):187–193.
- Rohr M, Yan Qi, Schrader A. Anti-wrinkle performance of cosmetic products differentiated by FOITS, A statement of effectiveness, age and ethnic background, IFSCC Congress 2006, Japan.
- Rohr M, Brandt M, Schrader A. Skin surface—claim support by FOITS. *SÖFW J* 2000; 126(8):2–11.
- Breuckmann B. Bildverarbeitung und optische Messtechnik in der industriellen Praxis. München: Franzis-Verlag GmbH, 1993.
- Schrader K. Untersuchungen wasser-retinierender Kosmetika auf der Haut. *Parfümerie Kosmet* 1981; 62:265–272.
- Piérard GE, Piérard-Franchimont C. Dihydroxyacetone test as a substitute for the dansyl chloride test. *Dermatology* 1993; 186: 133–137.
- Rohr M, Schrader A, Schrader K. The multifunctional effects of AHA. *Parfümerie Kosmet* 1996; 77:762–767.
- Neter J, Wassermann W, Kutner MH. Applied Linear Statistical Models, Regression, Analysis of Variance and Experimental Design. 2nd ed. Homewood: Irwin, 1984.
- Schrader A, Eckey H, Rohr M. Die Prüfung der Wirksamkeit reizlindernder Stoffe an der menschlichen Haut am Beispiel verschiedener Kamillenextrakte. *SÖFW J* 1997; 123:3–11.
- Schrader K. Praxisbezogene hautphysiologische Untersuchungskriterien mit Seifen und Syndets. *Parfümerie Kosmet* 1990; 71:686–695.

# Photodamage

Karen Connolly, Camile L. Hexsel, and Henry W. Lim

## INTRODUCTION

Electromagnetic radiation emitted by the sun includes ultraviolet (UV) (290–400 nm), visible (400–760 nm), and infrared radiation (IR) (760 nm–1 mm) (1,2). Table 4.1 outlines the spectrum of solar radiation, wavelength and depth of penetration and energy levels of each spectrum.

Sunlight reaching the surface of the earth consists of 5% ultraviolet radiation (UVR), 50% visible light, and 45% infrared (2). The subdivisions of UVR are defined as UVA (320–400 nm), UVB (290–320 nm), and UVC (200–290 nm) radiation with UVA further divided into UVA1 (320–340) and UVA2 (340–400 nm) (3). As one moves along the spectrum from the long-spectrum UVA to short-spectrum UVC, energy carried by each photon increases, hence accounting for the minimal erythema dose for UVB (MED-B) of 20 to 40 mJ/cm<sup>2</sup> for skin type I, and MED for UVA of 20 to 40 J/cm<sup>2</sup>. As wavelength increases, the depth of penetration into skin also increases (3). Although UVC's short wavelength and high energy content could potentially be the most damaging for skin, it is filtered out by the earth's ozone layer and does not have a measurable effect under normal circumstances. It is, however, found in some industries in the form of germicidal lamps (1). IR radiation is further subdivided into IRA (760–1400 nm), IRB (1400–3000 nm), and IRC (3000 nm–1 mm). With IR radiation, depth of penetration decreases as wavelength increases (4).

In this chapter, the acute and chronic effects of UV, visible light, and IR on the skin will be discussed.

## ACUTE EFFECTS OF UVR

Acute effects of UVR include erythema, edema, blisters, immediate and persistent pigment darkening followed by delayed tanning or neomelanogenesis, acanthosis, and dermal thickening. Exposure to UV can also induce immunosuppression, vitamin D synthesis, and development of photodermatoses (5).

## UV-Induced Erythema

UVR-induced erythema and edema are primarily induced by UVB, which starts at 3 to 4 hours after UVB exposure, and peaks at 8 to 24 hours; it lasts 24 to 48 hours or longer in light-skinned individuals. In contrast to UVB, UVA-induced erythema peaks at 1 to 2 hours after exposure and subsides gradually over 24 to 72 hours. Because of the longer wavelength of UVA, it takes 1000-fold more fluence to induce erythema by UVA, compared to UVB (5). Table 4.2 outlines the timeline of UVR-induced erythema. The familiar erythematous and edematous *sunburn* can be described on the basis of the cellular mechanisms involved: These include vascular leakage and dilatation, influx of an inflammatory infiltrate, apoptosis of

cells, and proliferation of keratinocytes. These effects begin with the absorption of UVR by the skin, a process called photoexcitation. The main targets for absorption are chromophores, which determine the depth of penetration of radiation. DNA is the major UV chromophore in human skin. Formation of cyclobutyl pyridine dimers (CPDs) is a hallmark of DNA damage and occurs at a peak action spectrum of 300 nm in the UVB range (6,7). One favored mechanism is that DNA damage activates cell death pathways via p53. This is followed by a reactive epidermal hyperplasia as early as six hours following UVR insult (8).

A number of inflammatory mediators are produced by keratinocytes upon UVB exposure, and many of these, including nitric oxide and prostaglandins, play a role in UVB-induced erythema (3,9). Other inflammatory cellular events induced by UVB radiation include degranulation of mast cells, release of TNF- $\alpha$  (10), upregulation of IL-8 (11), and subsequent infiltration of the dermis by neutrophils (12). Formation of sunburn cells, or damaged and apoptotic keratinocytes, followed by intercellular edema is another key feature of UV damage.

## UV-Induced Pigmentation

Another effect of solar radiation is increased pigmentation (Table 4.3). This process can be divided into three processes: Immediate pigment darkening (IPD), persistent pigment darkening (PPD), and the delayed tanning (DT) reaction (13). IPD occurs within seconds after UVA and visible light irradiation, and resolve in two hours; it is due to photooxidation of preexisting melanin. PPD is also a result of a photooxidation and redistribution of preexisting melanin; PPD persists from 2 to 24 hours after irradiation. Both of these responses occur more intensely with UVA exposure as opposed to UVB (14), and PPD has also been shown to be linearly dependent on the fluence of UVA reaching the skin surface (15,16). Recently, it has been demonstrated that exposure to visible light of individuals with skin types IV to VI also induces IPD and PPD (17).

In contrast to IPD and PPD, DT involved neomelanogenesis; it peaks at 72 hours (5) to 1 week after UV radiation and declines over at least 10 weeks (18). UVB-induced DT requires a preceding erythematous response and has a sun protection factor (SPF) of 3. UVA-induced DT tanning appears usually three days after exposure (5). Visible light-induced DT was observed by one week after exposure (17).

UVR has been shown, through damage to epidermal cell DNA, to increase synthesis of tyrosinase, a rate-limiting enzyme for melanogenesis. It has also been shown that DNA damage causes an increase in the activity of receptors for melanocyte-stimulating hormone, a melanotropic hormone (19,20).



**Table 4.1** Components of Solar Radiation, Wavelength, and Depth of Penetration

	UVC	UVB	UVA	Visible	Infrared
Wavelength	200–290 nm	290–320 nm	320–400 nm	400–760 nm	760 nm–1 mm
Subdivisions			UVA1: 320–340 nm UVA2: 340–400 nm		IRA: 760–1400 nm IRB: 1400–3000 nm IRC: 3000 nm–1 mm
Energy	Highest ----->				Lowest
Depth of penetration	Shallowest ----->			Deepest ----->	Shallowest

Abbreviations: UV, ultraviolet; IR, infrared.

**Table 4.2** Timeline of UVR-Induced Erythema

	Initial erythema	Peak erythema	Duration
UVA	Immediately after exposure	1–2 hr	24–72 hr
UVB	3–4 hr after exposure	8–24 hr	24–48 hr

Abbreviations: UVR, ultraviolet radiation; UV, ultraviolet.

### Immunosuppression

A number of immune cells are present in normal human skin, including keratinocytes, Langerhans cells, the resident dendritic antigen presenting cells, dermal and plasmacytoid dendritic cells, T cells, mast cells, and macrophages (21). UVR can induce local and systemic immune suppression, even at suberythrogenic levels. UVR-induced immunosuppression appears to be somewhat dose-dependant and varies on the basis of UVA or UVB exposure (22). The interplay between UVA and UVB has not been entirely described, but it appears that different doses of UVA determine whether it acts as an immunosuppressant or immunoprotectant (21).

UVB exposure has been shown to suppress Th1 cytokine responses to application of a contact hypersensitivity-inducing antigen up to three days following the UVB exposure, while UVA can produce a more short-acting Th1 cytokine response at higher doses (23). Both UVA and UVB can induce reduction of epidermal Langerhans cells (24).

Other effects of UVR on immunosuppression include the release of immunosuppressive cytokines and mediators, induction of regulatory/suppressor T cells, suppression of antigen presentation, and induction of immunologic tolerance (25).

The concept of UVR-induced immunosuppression has particular relevance to the development and persistence of skin cancer in humans, since UVR prevents rejection of highly immunogenic UV-induced tumors in mice that have been irradiated. These tumors are rapidly rejected in nonirradiated mice, suggesting that UVR allows persistence of UV-induced neoplasms (26).

### Vitamin D Synthesis

In recent years, it has been recognized that low levels of vitamin D may be associated not only with proper maintenance of blood levels of calcium and phosphate for bone health, but also as protective for certain malignancies, cardiovascular diseases, bone disease, type 1 diabetes, and possibly autoimmune conditions (27,28). There are three sources for obtaining vitamin D precursors: cutaneous vitamin D metabolism, oral ingestion of vitamin D supplements/food supplemented with vitamin D, and natural animal sources of vitamin D (29).

The action spectrum of cutaneous vitamin D photosynthesis is in the UVB range, with a peak at  $300 \pm 5$  nm. The pathway involves conversion of cutaneous 7-dehydrocholesterol to cholecalciferol, which undergoes further metabolism in the liver to 25-hydroxyvitamin D, and in the kidneys to the active metabolite, 1,25-hydroxyvitamin D (29,30). The metabolite commonly measured to assess vitamin D status is serum 25-hydroxyvitamin D (30). Production reaches a maximum at less than one minimal erythema dose, which can be achieved for approximately two to eight minutes outside on a sunny day for a light-skinned individual (27). This estimate varies on the basis of season, time of year, time of day, skin type, and latitude.

The other routes for obtaining vitamin D are through oral ingestion of vitamin D supplements, vitamin D-fortified foods like milk and milk products, or vitamin D-rich natural food sources such as fatty fish.

Sun and UV exposure has been advocated by some, including the tanning industry, as a necessary means for obtaining vitamin D levels. However, the peak action spectrum for vitamin D photosynthesis is around 300 nm, similar to the peak wavelengths for erythema and pigmentation responses, and formation of CPDs. UVR is a well-known carcinogen (27); recently, WHO has classified tanning beds as carcinogenic (31). Studies have shown that even with abundant unprotected sun exposure (several hours per day), some individuals do not synthesize adequate levels of vitamin D, especially darker-skinned individuals (27,32). Therefore, for individuals at risk for vitamin D insufficiency, it is recommended that oral vitamin

**Table 4.3** Timeline of UVR-Induced Pigmentation

	Mechanism	Peak response	Main contributing range of UVR	Duration
IPD	Photooxidation of preexisting melanin	Within seconds of exposure	UVA and visible light	2 hr
PPD	Photooxidation and redistribution of preexisting melanin	2–24 hr	UVA and visible light	2 to 24 hr
DT	Neomelanogenesis	72 hr–1 wk	UVB, UVA and visible light	Up to 10 wk

Abbreviations: IPD, immediate pigment darkening; PPD, persistent pigment darkening; DT, delayed tanning; UVR, ultraviolet radiation; UV, ultraviolet.

**Table 4.4** Clinical Differences Between Chronologic Aging and Photoaging

	Chronologic aging	Photoaging
Pigmentation	Regular	Diffusely irregular
Thickness	Thinning of skin, increased laxity	Thickened skin
Texture	Smooth and atrophied	Leathery, wrinkled, dry, and rough
Blood vessels	Decrease in number	Telangiectasias
Inflammation	Absent	Present
Distinctive features		Cutis rhomboid nuchae

D<sub>3</sub> at 1000 IU daily be taken; they should not be advised to obtain vitamin D from natural or artificial UV (33).

## CHRONIC EFFECTS OF UVR Photoaging

Clinical features of photoaging, along with differences from normal intrinsic aging, are outlined in Table 4.4 (34–36).

Histopathologically, photodamaged skin presents with hyperkeratosis and acanthosis. In addition, classic characterized effects of photoaging are due to damage of the dermal connective tissue and include the presence of numerous hyperplastic fibroblasts, irregular and disorganized collagen bundles that acquire a distinctive basophilic staining, increased and amorphous elastin, thickened vessels, and increased glycosaminoglycans and inflammatory cells.

UV radiation results in generation of reactive oxygen species (ROS) and free radicals, as well as increased activation of growth factor receptors in keratinocytes and fibroblasts, resulting in upregulation of matrix metalloproteinases (MMPs), which degrade various components of the extracellular matrix, such as elastin and collagen (36–38).

UVB is mostly absorbed in the epidermis. It plays a role in photoaging by induction of transcription factors, such as nuclear factor- $\kappa$  B and other proinflammatory cytokines, expression of MMPs, induction of CPDs, as well as generation of pyrimidine-pyrimidone photodimers, photoisomerization of *trans*- to *cis*-urocanic acid, and generation of ROS (39). Furthermore, amino acids that cross-link collagen and elastin, melanin (6), tryptophan, and tyrosine (40) are additional potential targets of UVB radiation.

Compared to UVB, UVA generates more oxidative stress, is more phototoxic, and is 10 times more efficient in causing lipid peroxidation. UVA also induces MMP synthesis, and the formation of nicks in the DNA, mitochondrial DNA base deletions in the fibroblasts, and the formation of 8-hydroxythioguanine.

Telangiectasias are thought to occur from the effect of UVR in increasing vascular endothelial growth factor and platelet-derived endothelial growth factor, and from downregulation of angiogenesis inhibition (39).

## Photocarcinogenesis and Development of Actinic Keratosis

As previously discussed, UVB is especially important in the formation of CPDs and UVA in the development of ROS, which can further damage DNA. Many studies have implicated these entities directly in the carcinogenesis of skin cancers and actinic keratoses. Actinic keratoses (AKs) are a reflection of over

exposure to sunlight, occurring in up to 50% of fair-skinned population greater than 40 years (41). They are precursor lesion to carcinoma in situ and eventually squamous cell carcinoma (SCC). AKs occur in individuals with light skin, since melanin in dark-skinned individuals provide natural photoprotection. An important risk factor for development of AKs and skin cancers is age, as the rates of incidence increase exponentially as age increases. Age-related differences in the immune system may play a role (42). AKs are located in sun-exposed sites (43), and the incidence of AKs in people who work outdoor or spend lots of recreational time in the sun is higher than in people who work indoors (41). Support for AK and SCC lying on a biologic continuum relies on the progression of AK to SCC: about 0.1% to 10% will progress in a 1-year period (44), and 6% to 10% over 10 years (45). Although AKs are not thought to progress to become basal cell carcinomas (BCCs), a high number of AKs is a risk factor for BCCs as well.

As opposed to cumulative, chronic UVR being responsible for the development and progression of AK and SCC, it is thought that intermittent, intense sun exposure, and childhood UVR with sunburns are more important risk factors for development of BCC and melanoma (46–52). Although it is agreed that development of melanoma is related to sun exposure, the association is not as clear as with other skin cancers (47). Major risk factors include total sun exposure, altered or irregular patterns of exposure, fair-skinned complexion, history of painful sunburns before the age of 20 years, freckling, and location close to the equator (42,49,53). Melanoma and other skin cancers have been induced by UVR in animals (54,55). Additionally, the incidence of these entities is inversely related to latitude (49). Melanomas most commonly affect the back in males and the lower legs in females, and are more common in people with indoor jobs, supporting the idea that it is intermittent, intense exposure and not chronic cumulative exposure to UVR that is involved in its pathogenesis (46).

Mutation of critical genes is thought to be the mechanism through which UVR induces development of AK and skin cancers. The *p53* tumor suppressor gene plays an important role in the pathogenesis of skin cancers and other malignancies. The normal function of this gene is to serve as a guardian for the genome by inducing apoptosis in a cell in which its DNA has been damaged. Signature mutations of the *p53* gene that are induced by UVR are found in up to 80% of AKs and 90% of SCC. It is also thought to be involved in BCC. The *p16* tumor suppressor gene is implicated in the development of melanoma (56). The Hedgehog pathway and *PTCH1* gene are thought to be involved in the pathogenesis of BCC (57).

## CUTANEOUS EFFECTS OF VISIBLE LIGHT

Visible light accounts for the spectrum of solar radiation ranging from 400 to 760 nm and produces the general illumination visible to the human eye. Solar radiation reaching the earth's surface consists of about 50% visible light (39). The biological effects of visible light on human skin have not been fully studied. Chromophores that absorb wavelengths along the visible light spectrum include  $\beta$ -carotene, protoporphyrin IX, melanin, water, riboflavin, bilirubin, and hemoglobin. Among them, several have an action spectrum that includes UVR wavelengths. The existing studies focusing on visible light have shown that it can produce erythema, pigmentation, and ROS (58).

## Erythema

Although UVB is most frequently considered responsible for the erythema produced by sunlight, visible light has also been shown to produce an immediate erythema that fades over 24 hours (59). This is thought to result from dilatation of the subpapillary plexus, since the longer wavelength of visible light allows its deeper penetration into skin (58,60).

## Pigmentation (IPD and PPD)

Visible light can produce an IPD, a PPD, and a DT reaction that can last at least 14 days (17,59). Kollias and Baqer studied the effects of visible and near-infrared light on pigmentation and also found an IPD and a DT effect (61).

## ROS Formation

Visible light has been implicated in production of ROS in wavelength ranges close to UVA1. Kielbassa and Epe, have demonstrated DNA damage likely via ROS in cells exposed to visible light of wavelengths from 400 to 500 nm (62,63). It has been shown that visible light may contribute one-third to one-half of ROS damage produced by solar radiation (64,65). Visible light has also been shown to induce p53 expression in epidermal cells and to induce epidermal proliferation, but to a lesser degree than UVA irradiation (66).

## CUTANEOUS EFFECTS OF IR

IR radiation ranges from wavelengths 760 nm to 1 mm and is invisible to the human eye. It composes about 45% of sunlight reaching the earth's surface (39) and is also used in a variety of cosmetic modalities. IR lies on the electromagnetic spectrum between visible light and microwaves and is further divided on the basis of wavelength into IRA (760–1400 nm), IRB (1400–3000 nm), and IRC (3000 nm–1 mm). IR can also be divided into near-IR (760–3000 nm), middle-IR (3000–30,000 nm), and far-IR (30,000 nm–1 mm). Among these, IRA appears to be most important for photoaging because of its penetration to the dermis (67), whereas IRB and IRC penetrate to the epidermis and are responsible for the increase in skin temperature (68). IR can produce heat via molecular vibrations and rotations on absorption, especially IRC, and this may contribute to its physiologic effects (4).

## Photoaging

IR has been shown to induce expression of several mediators associated with photoaging independently of and also with production of heat. IR and visible light in combination can increase expression of MMPs and decrease procollagen expression, events that cause connective tissue damage (67,68). IR and visible light can also cause macrophage infiltration of the skin (68–70) and induces cutaneous angiogenesis and inflammatory cellular infiltration (68). Furthermore, mast cells are recruited to the skin not only by UV but also by IR (71). The angiogenesis is at least in part regulated by the increase in skin temperature from IR (72). In mouse studies, IR has been shown to induce wrinkles and augment UV-induced damage both clinically and histologically, suggesting that it is important in photoaging (73). Interestingly, it appears that IR causes photoaging damage via a different mechanism than UVR. Schroeder et al. recently showed that IRA causes mitochondrial ROS production via the electron transport chain, which is thought to cause MMP-1

expression via retrograde signaling (74). This production of ROS has been shown to cause oxidative DNA damage and induction of MMP as well (68).

## ACKNOWLEDGMENT

Dr Lim is a consultant for La Roche-Posay, Orfagen, Johnson & Johnson, and Dow Pharmaceuticals and he has received research grant support from Johnson and Johnson.

Conflict of Interest: Karen Connolly and Dr Hexsel have no conflicts of interest to declare.

## REFERENCES

1. Matsumura Y, Ananthaswamy HN. Toxic effects of ultraviolet radiation on the skin. *Toxicol Appl Pharmacol* 2004; 195(3):298–308.
2. Diffey BL. Sources and measurement of ultraviolet radiation. *Methods* 2002; 28(1):4–13.
3. Clydesdale GJ, Dandie GW, Muller HK. Ultraviolet light induced injury: immunological and inflammatory effects. *Immunol Cell Biol* 2001; 79(6):547–568.
4. Schieke SM, Schroeder P, Krutmann J. Cutaneous effects of infrared radiation: from clinical observations to molecular response mechanisms. *Photodermatol Photoimmunol Photomed* 2003; 19(5):228–234.
5. Kullavanijaya P, Lim HW. Photoprotection. *J Am Acad Dermatol* 2005; 52(6):937–958; quiz 59–62.
6. Trautinger F. Mechanisms of photodamage of the skin and its functional consequences for skin ageing. *Clin Exp Dermatol* 2001; 26(7):573–577.
7. Freeman SE, Hacham H, Gange RW, et al. Wavelength dependence of pyrimidine dimer formation in DNA of human skin irradiated in situ with ultraviolet light. *Proc Natl Acad Sci U S A* 1989; 86(14):5605–5609.
8. Jans J, Garinis GA, Schul W, et al. Differential role of basal keratinocytes in UV-induced immunosuppression and skin cancer. *Mol Cell Biol* 2006; 26(22):8515–8526.
9. Deliconstantinos G, Villiotou V, Stravrides JC. Release by ultraviolet B (u.v.B) radiation of nitric oxide (NO) from human keratinocytes: a potential role for nitric oxide in erythema production. *Br J Pharmacol* 1995; 114(6):1257–1265.
10. Walsh LJ. Ultraviolet B irradiation of skin induces mast cell degranulation and release of tumour necrosis factor-alpha. *Immunol Cell Biol* 1995; 73(3):226–233.
11. Strickland I, Rhodes LE, Flanagan BF, et al. TNF-alpha and IL-8 are upregulated in the epidermis of normal human skin after UVB exposure: correlation with neutrophil accumulation and E-selectin expression. *J Invest Dermatol* 1997; 108(5):763–768.
12. Hawk JL, Murphy GM, Holden CA. The presence of neutrophils in human cutaneous ultraviolet-B inflammation. *Br J Dermatol* 1988; 118(1):27–30.
13. Lavker RM, Kaidbey KH. Redistribution of melanosomal complexes within keratinocytes following UV-A irradiation: a possible mechanism for cutaneous darkening in man. *Arch Dermatol Res* 1982; 272(3–4):215–228.
14. Miyamura Y, Coelho SG, Wolber R, et al. Regulation of human skin pigmentation and responses to ultraviolet radiation. *Pigment Cell Res* 2007; 20(1):2–13.
15. Moyal D, Chardon A, Kollias N. UVA protection efficacy of sunscreens can be determined by the persistent pigment darkening (PPD) method. (Part 2). *Photodermatol Photoimmunol Photomed* 2000; 16(6):250–255.
16. Parrish JA, Jaenicke KF, Anderson RR. Erythema and melanogenesis action spectra of normal human skin. *Photochem Photobiol* 1982; 36(2):187–191.
17. Mahmoud BH, Ruvolo E, Hexsel CL, et al. Effects of UVA1 and visible light on dark skin. 18th Annual Meeting of Photomedicine Society, March 5, 2009, San Francisco, CA, USA.

18. Oh C, Hennessy A, Ha T, et al. The time course of photoadaptation and pigmentation studied using a novel method to distinguish pigmentation from erythema. *J Invest Dermatol* 2004; 123(5):965–972.
19. Nylander K, Bourdon JC, Bray SE, et al. Transcriptional activation of tyrosinase and TRP-1 by p53 links UV irradiation to the protective tanning response. *J Pathol* 2000; 190(1):39–46.
20. Park HY, Kosmadaki M, Yaar M, et al. Cellular mechanisms regulating human melanogenesis. *Cell Mol Life Sci* 2009; 66(9): 1493–1506.
21. Halliday GM, Rana S. The effects of solar radiation on the immune response in humans. In: Giacomoni P, ed. *Biophysical and Physiological Effects of Solar Radiation on Human Skin*. Cambridge: RSC Publishing, 2007:127–163.
22. Poon TS, Barnetson RS, Halliday GM. Sunlight-induced immunosuppression in humans is initially because of UVB, then UVA, followed by interactive effects. *J Invest Dermatol* 2005; 125(4): 840–846.
23. Shen J, Bao S, Reeve VE. Modulation of IL-10, IL-12, and IFN-gamma in the epidermis of hairless mice by UVA (320–400 nm) and UVB (280–320 nm) radiation. *J Invest Dermatol* 1999; 113(6): 1059–1064.
24. Halliday GM, Bestak R, Yuen KS, et al. UVA-induced immunosuppression. *Mutat Res* 1998; 422(1):139–145.
25. Schwarz T, Halliday GM. Photoimmunology. In: Lim HW, Honigsmann H, Hawk JLM, eds. *Photodermatology*. New York: Informa Healthcare, 2007:75–90.
26. Kripke ML, Thorn RM, Lill PH, et al. Further characterization of immunological unresponsiveness induced in mice by ultraviolet radiation. Growth and induction of nonultraviolet-induced tumors in ultraviolet-irradiated mice. *Transplantation* 1979; 28(3):212–217.
27. Gilchrist BA. Sun exposure and vitamin D sufficiency. *Am J Clin Nutr* 2008; 88(2):570S–577S.
28. Bischoff-Ferrari H, Lim HW. Effect of photoprotection on vitamin D and health. In: Lim HW, Draelos ZD, eds. *A Clinical Guide to Sunscreens and Photoprotection*. New York: Informa Healthcare 2009:117–138.
29. Youl PH, Janda M, Kimlin M. Vitamin D and sun protection: the impact of mixed public health messages in Australia. *Int J Cancer* 2009; 124(8):1963–1970.
30. Brannon PM, Yetley EA, Bailey RL, et al. Overview of the conference “Vitamin D and Health in the 21st Century: an Update”. *Am J Clin Nutr* 2008; 88(2):483S–490S.
31. El Ghissassi F, Baan R, Straif K, et al. A review of human carcinogens—part D: radiation. *Lancet Oncol* 2009; 10(8):751–752.
32. Binkley N, Novotny R, Krueger D, et al. Low vitamin D status despite abundant sun exposure. *J Clin Endocrinol Metab* 2007; 92(6):2130–2135.
33. Position statement on vitamin D. Available at: <http://www.aad.org/forms/policies/uploads/ps/ps-vitamin%20d.pdf>. Accessed August 22.
34. Lavker RM. Cutaneous aging: chronologic versus photoaging. In: Gilchrist BA, ed. *Photodamage*. Cambridge: Blackwell Science, 1995:123–135.
35. Bernstein EF, Uitto J. The effect of photodamage on dermal extracellular matrix. *Clin Dermatol* 1996; 14(2):143–151.
36. Ma W, Wlaschek M, Tancheva-Poor I, et al. Chronological ageing and photoageing of the fibroblasts and the dermal connective tissue. *Clin Exp Dermatol* 2001; 26(7):592–599.
37. Wlaschek M, Schneider L, Kohn M, et al. Aging after solar radiation. In: Giacomoni P, ed. *Biophysical and Physiological Effects of Solar Radiation on Human Skin*. Cambridge: RSC Publishing, 2007:191–210.
38. Brenneisen P, Sies H, Scharffetter-Kochanek K. Ultraviolet-B irradiation and matrix metalloproteinases: from induction via signaling to initial events. *Ann N Y Acad Sci* 2002; 973:31–43.
39. Gonzaga ER. Role of UV light in photodamage, skin aging, and skin cancer: importance of photoprotection. *Am J Clin Dermatol* 2009; 10:19.
40. Babu V, Joshi PC. Tryptophan as an endogenous photosensitizer to elicit harmful effects of ultraviolet B. *Indian J Biochem Biophys* 1992; 29(3):296–298.
41. Salasche SJ. Epidemiology of actinic keratoses and squamous cell carcinoma. *J Am Acad Dermatol* 2000; 42(1 pt 2):4–7.
42. Gilchrist BA, Eller MS, Geller AC, et al. The pathogenesis of melanoma induced by ultraviolet radiation. *N Engl J Med* 1999; 340(17):1341–1348.
43. Frost CA, Green AC. Epidemiology of solar keratoses. *Br J Dermatol* 1994; 131(4):455–464.
44. Marks R, Rennie G, Selwood TS. Malignant transformation of solar keratoses to squamous cell carcinoma. *Lancet* 1988; 1(8589): 795–797.
45. Dodson JM, DeSpain J, Hewett JE, et al. Malignant potential of actinic keratoses and the controversy over treatment. A patient-oriented perspective. *Arch Dermatol* 1991; 127(7): 1029–1031.
46. Bentham G, Aase A. Incidence of malignant melanoma of the skin in Norway, 1955–1989: associations with solar ultraviolet radiation, income and holidays abroad. *Int J Epidemiol* 1996; 25(6):1132–1138.
47. Weinstock MA. Controversies in the role of sunlight in the pathogenesis of cutaneous melanoma. *Photochem Photobiol* 1996; 63(4):406–410.
48. Han J, Colditz GA, Hunter DJ. Risk factors for skin cancers: a nested case-control study within the Nurses’ Health Study. *Int J Epidemiol* 2006; 35(6):1514–1521.
49. Mack TM, Floderus B. Malignant melanoma risk by nativity, place of residence at diagnosis, and age at migration. *Cancer Causes Control* 1991; 2(6):401–411.
50. Leiter U, Garbe C. Epidemiology of melanoma and nonmelanoma skin cancer—the role of sunlight. In: Reichrath J, ed. *Sunlight, Vitamin D and Skin Cancer*. New York: Springer Science+Business Media, 2008.
51. Garbe C, Leiter U. Melanoma epidemiology and trends. *Clin Dermatol* 2009; 27(1):3–9.
52. Rigel DS. Cutaneous ultraviolet exposure and its relationship to the development of skin cancer. *J Am Acad Dermatol* 2008; 58(5 suppl 2):S129–S132.
53. Kennedy C, Bajdik CD, Willemze R, et al. The influence of painful sunburns and lifetime sun exposure on the risk of actinic keratoses, seborrheic warts, melanocytic nevi, atypical nevi, and skin cancer. *J Invest Dermatol* 2003; 120(6):1087–1093.
54. Setlow RB, Woodhead AD, Grist E. Animal model for ultraviolet radiation-induced melanoma: platyfish-swordtail hybrid. *Proc Natl Acad Sci U S A* 1989; 86(22):8922–8926.
55. Kusewitt DF, Applegate LA, Ley RD. Ultraviolet radiation-induced skin tumors in a South American opossum (*Monodelphis domestica*). *Vet Pathol* 1991; 28(1):55–65.
56. Hussein MR. Ultraviolet radiation and skin cancer: molecular mechanisms. *J Cutan Pathol* 2005; 32(3):191–205.
57. Rass K, Reichrath J. UV damage and DNA repair in malignant melanoma and nonmelanoma skin cancer. In: Reichrath J, ed. *Sunlight, Vitamin D and Skin Cancer*. New York: Springer Science+Business Media, 2008.
58. Mahmoud BH, Hexsel CL, Hamzavi IH, et al. Effects of visible light on the skin. *Photochem Photobiol* 2008; 84(2):450–462.
59. Porges SB, Kaidbey KH, Grove GL. Quantification of visible light-induced melanogenesis in human skin. *Photodermatol* 1988; 5(5):197–200.
60. Rottier PB, Van Der Leun JC. Hyperaemia of the deeper cutaneous vessels after irradiation of human skin with large doses of ultraviolet and visible light. *Br J Dermatol* 1960; 72:256–260.
61. Kollias N, Baqer A. An experimental study of the changes in pigmentation in human skin in vivo with visible and near infrared light. *Photochem Photobiol* 1984; 39(5):651–659.
62. Kielbassa C, Roza L, Epe B. Wavelength dependence of oxidative DNA damage induced by UV and visible light. *Carcinogenesis* 1997; 18(4):811–816.

63. Kielbassa C, Epe B. DNA damage induced by ultraviolet and visible light and its wavelength dependence. *Methods Enzymol* 2000; 319:436-445.
64. Haywood R. Relevance of sunscreen application method, visible light and sunlight intensity to free-radical protection: a study of ex vivo human skin. *Photochem Photobiol* 2006; 82(4):1123-1131.
65. Zastrow L, Groth N, Klein F, et al. [UV, visible and infrared light. Which wavelengths produce oxidative stress in human skin?]. *Hautarzt* 2009; 60(4):310-317.
66. Edstrom DW, Porwit A, Ros AM. Effects on human skin of repetitive ultraviolet-A1 (UVA1) irradiation and visible light. *Photodermatol Photoimmunol Photomed* 2001; 17(2):66-70.
67. Schroeder P, Calles C, Krutmann J. Prevention of infrared-A radiation mediated detrimental effects in human skin. *Skin Therapy Lett* 2009; 14(5):4-5.
68. Cho S, Shin MH, Kim YK, et al. Effects of infrared radiation and heat on human skin aging in vivo. *J Investig Dermatol Symp Proc* 2009; 14(1):15-19.
69. Cho S, Lee MJ, Kim MS, et al. Infrared plus visible light and heat from natural sunlight participate in the expression of MMPs and type I procollagen as well as infiltration of inflammatory cell in human skin in vivo. *J Dermatol Sci* 2008; 50(2):123-133.
70. Kim MS, Kim YK, Cho KH, et al. Regulation of type I procollagen and MMP-1 expression after single or repeated exposure to infrared radiation in human skin. *Mech Ageing Dev* 2006; 127(12):875-882.
71. Kim MS, Kim YK, Lee DH, et al. Acute exposure of human skin to ultraviolet or infrared radiation or heat stimuli increases mast cell numbers and tryptase expression in human skin in vivo. *Br J Dermatol* 2009; 160(2):393-402.
72. Kim MS, Kim YK, Cho KH, et al. Infrared exposure induces an angiogenic switch in human skin that is partially mediated by heat. *Br J Dermatol* 2006; 155(6):1131-1138.
73. Kim HH, Lee MJ, Lee SR, et al. Augmentation of UV-induced skin wrinkling by infrared irradiation in hairless mice. *Mech Ageing Dev* 2005; 126(11):1170-1177.
74. Krutmann J, Schroeder P. Role of mitochondria in photoaging of human skin: the defective powerhouse model. *J Investig Dermatol Symp Proc* 2009; 14(1):44-49.

## Skin barrier cream efficacy: evidence based

Hongbo Zhai, Heidi P. Chan, and Howard I. Maibach

### INTRODUCTION

The skin provides a protective shield between us and environmental toxicity. This is evident in certain occupations where there is constant exposure to hazardous substances. Precautionary measures such as glove use minimize the risk of incurring contact dermatitis (CD), but in many professions this is impossible because of the loss of dexterity. An alternative measure is to utilize barrier creams (BC), which may play an important role in the prevention of CD (1–7). BC are also used to protect the face and neck against chemical and resinous dust and vapors (8). Many prefer to use BC rather than gloves because they do not want the hand continuously sealed inside a glove that can inhibit skin barrier function (6). In addition, many gloves do not resist the penetration of low molecular weight chemicals and some allergens are soluble in rubber gloves that may penetrate the glove and produce severe dermatitis (6,9,10). Allergy to rubber latex has become a growing problem (6,10). Furthermore, because of continuous glove wearing, workers can develop serious symptoms (i.e., contact urticaria syndrome) including generalized urticaria, conjunctivitis, rhinitis, and asthma, etc. (6,11). Additionally, BC can be used against chemical warfare agents (12,13). However, their utilization remains the subject of a lively debate; some suggest that the inappropriate BC application may exacerbate rather than prevent irritation (1–3,6,14–16). The accuracy of measurements depends on the use of appropriate methodology and hence various *in vitro* and *in vivo* methods have been developed to evaluate their efficacy. This chapter reviews methodology and efficacy of BC.

### IN VITRO METHODS

In 1946, Sadler and Marriott (17) introduced facile tests to evaluate the efficiency of BC. One method used the fluorescence of a dyestuff and eosin as an indicator to measure penetration and the rates of penetration of water through BC; this is rapid and simple, but provides only a qualitative estimate.

Suskind (18) performed a simple method to measure the relative efficacy or repellency of formulations with film immersion test in a specific exposure. Formulation containing 52.5% silicone in bentonite, and 30% silicone in petrolatum were effective against a range of aqueous irritants and sensitizers.

Langford (19) conducted *in vitro* studies to determine the efficacy of the formulated fluorochemical (FC)-resin complex included solvent penetration through treated filter paper, solvent repellency on treated pig skin, and penetration of radio-tagged sodium lauryl sulfate (SLS) through treated hairless mouse skin. He also conducted an *in vivo* study on 75 persons who had previously experienced irritation on their hands due

to continued contact with solvents. 83% of the panelists stated the cream was effective in protecting their hands.

Reiner et al. (20) examined the protective effect of ointments on guinea pig skin *in vitro* and *in vivo*. The permeation values of a toxic agent through unprotected and protected skin within 10 hours as a function of time was determined radiologically and enzymatically. Permeation of the toxic agent was markedly reduced by polyethylene glycol ointment base and ointments containing active substance. In *in vivo* experiments on guinea pigs mortality was greater after applying the toxic agent to unprotected skin. All formulations with nucleophilic substances markedly reduced the mortality rate.

Loden (21) evaluated the effect of BC on the absorption of (<sup>3</sup>H) water (<sup>14</sup>C)-benzene and (<sup>14</sup>C)-formaldehyde into excised human skin. The control and the BC-treated skins were exposed to the test substance for 0.5 hour, whereupon absorption was determined. The experimental cream “water barrier” reduced the absorption of water and benzene but not formaldehyde. One cream slightly reduced benzene and formaldehyde absorption. Two other creams did not affect the absorption of the substances studied.

Treffel et al. (22) measured *in vitro* on human skin the effectiveness of BC against three dyes (eosin, methylviolet, and oil red O) with varying n-octanol/water partition coefficients (0.19, 29.8, and 165, respectively). BC efficacy was assayed by measurements of the dyes in the epidermis of protected skin samples after 30-minute application. The efficacy of BC against the three dyes showed in several cases data contrary to manufacturer’s information. There was no correlation between the galenic parameters of the assayed products and the protection level, indicating that neither the water content nor the consistency of the formulations influenced the protection effectiveness.

Fullerton and Menne (23) examined the protective effect of ethylenediaminetetraacetate (EDTA) barrier gels against nickel contact allergy using *in vitro* and *in vivo* methods. In an *in vitro* study, about 30 mg of barrier gel was applied on the epidermal side of the skin and a nickel disk was placed above the gel. After 24-hour application, the nickel disk was removed and the epidermis separated from the dermis. Nickel content in epidermis and dermis was quantified by adsorption differential pulse voltammetry (ADPV). The amount of nickel in the epidermal skin layer on barrier gels treated skins was significantly reduced compared with the untreated control. *In vivo* patch testing of nickel-sensitive patients was performed using nickel disks with and without barrier gels. Test preparations and nickel disks were removed one day post application, and the test sites were evaluated. Reduction in positive test reactions was highly significant at barrier gels treated sites.

Zhai et al. (24) utilized an *in vitro* diffusion system to measure the protective effectiveness of quaternium-18 bentonite

(Q18B) gels to prevent 1% concentration of [<sup>35</sup>S]-SLS penetration by human cadaver skin. The accumulated amount of [<sup>35</sup>S]-SLS in receptor cell fluid were counted to evaluate the efficacy of the Q18B gels over 24 hours. These test gels significantly decreased SLS absorption when compared with the unprotected skin control samples. The percent protection effect of three test gels against SLS percutaneous absorption was from 88%, 81%, and 65%, respectively.

Millerioux et al. (25) validated screening tests by utilizing two in vitro skin permeation models: split-thickness skin from pig ears and semipermeable silicone membranes disposed in Franz-type diffusion cells. The protective efficacy of three formulations, oil-in-water and water-in-oil emulsions, and perfluorinated compounds-based cream against the neurotoxic organophosphorus compounds (OP) was evaluated. Results indicated that the least effective formulations could be quickly identified by performing in vitro permeation tests with silicone membrane and by evaluating interfacial interactions between formulations and OP. Among the tested formulations, the perfluorinated compounds-based cream could have a broader spectrum of efficacy than emulsions against OP and other toxic chemicals.

## IN VIVO METHODS

Schwartz et al. (26) introduced an in vivo method to evaluate the efficacy of a vanishing cream against poison ivy extract utilizing visual erythema on human skin. The test cream was an effective prophylaxis against poison ivy dermatitis where compared with unprotected skin.

Lupulescu and Birmingham (27) observed the ultrastructural and relief changes of human epidermis following exposure to a protective gel and acetone and kerosene on humans. Unprotected skin produced cell damage and a disorganized pattern in the upper layers of epidermis. Protective agent prior to solvent exposure substantially reduced the ultrastructural and relief changes of epidermis cells.

Lachapelle et al. (3,28–31) utilized a guinea pig model to evaluate the protective value of BC and/or gels by laser Doppler flowmetry and histological assessment. The histopathological damage after 10 minutes of contact to toluene was mostly confined to the epidermis while the dermis was almost normal. The dermal blood flow changes were relatively high on the control site compared with the gel pretreated sites.

Frosch et al. (1,15,16,32,33) developed the repetitive irritation test (RIT) in the guinea pig and in humans to evaluate the efficacy of BC using bioengineering techniques. The cream pretreated and untreated test skin (guinea pigs or humans) were exposed daily to the irritants for two weeks. The resulting irritation was scored on a clinical scale and assessed by biophysical techniques' parameters. Some test creams suppressed irritation with all test parameters; some failed to show such an effect, and even exacerbated (16).

Zhai and Maibach (2) utilized an in vivo human model to measure the effectiveness of BC against dye indicator solutions: methylene blue in water and oil red O in ethanol, representative of model hydrophilic and lipophilic compounds. Solutions of 5% methylene blue and 5% oil red O were applied to untreated and BC pretreated skin with the aid of aluminum occlusive chambers for zero and four hours. At the end of the application time, the materials were removed, and consecutive skin surface biopsies (SSB) obtained. The amount of dye penetrating into each strip was determined by colorimetry. Two

creams exhibited effectiveness, but one cream enhanced cumulative amount of dye.

Zhai et al. (5) introduced a facile approach to screening protectants in vivo in human subjects. Two acute irritants and one allergen were selected: SLS representative of irritant household and occupational CD, the combination of ammonium hydroxide (NH<sup>4</sup>OH) and urea to simulate diaper dermatitis, and Rhus to evaluate the effect of model protective materials. Test materials were spread over onto test area, massaged, allowed to dry for 30 minutes, and reapplied with another 30-minute drying period. The model irritants and allergen were applied with an occlusive patch for 24 hours. Inflammation was scored with an expanded 10-point scale at 72 hours post application. Most test materials statistically suppressed the SLS irritation and Rhus allergic reaction and not NH<sup>4</sup>OH and urea induced irritation.

Wigger-Alberti et al. (34) determined which areas of the hands were likely to be skipped on self-application of BC by fluorescence technique at workplace. Results showed the application of BC was incomplete, especially on the dorsal aspects of the hands.

Draeos (35) conducted a randomized, double-blind, split-body study in 80 men, women and children (neonate) with the following dermatological conditions: household dermatitis, occupational hand dermatitis, latex glove irritant CD, diaper dermatitis, cutaneous wounds, and allergic CD. The subjects were given two identical jars (one jar containing petrolatum-based cream, and the other contained hydrogel-based barrier/repair cream) and were instructed to apply one cream to half of their bodies, while the other cream to the other half for four weeks. Results showed 62% of the subjects preferred hydrogel-based barrier/repair cream over the petrolatum-based cream ( $p \leq 0.005$ ), as well as the investigator's assessment ( $p \leq 0.000,01$ ) in terms of the overall skin appearance.

McCormick et al. (36) performed a double-blind, randomized trial comparing a novel BC versus an oil-containing lotion in 54 health care workers for two months. Results showed that both creams substantially protected the health care workers against drying and chemical irritation, preventing skin breakdown and promoting more frequent handwashing.

The skin protection efficacy of dexapanthenol was investigated by Biro et al. (37) in a double-blind, randomized, placebo-controlled study design in 25 healthy volunteers. They compared a cream containing 5% dexapanthenol with its vehicle moisturizing base, and applied to the flexor forearms twice daily for 26 days—one arm treated by the test product, while the other treated with placebo. In days 15 to 25, 2% SLS were treated on both forearms. Measures of skin physiology included sebumetry, corneometry, pH values and clinical appearance (photographs). Results showed, though not significantly, a decreasing trend of the pH values and decrease in sebum content during SLS treatment but normalized when SLS was discontinued. Hydration of the stratum corneum remained stable throughout the study in the dexapanthenol group, while corneometry for the placebo group showed a significant ( $p < 0.05$ ) decrease at the end of the SLS treatment on day 23. This study demonstrates the capability of dexapanthenol to protect skin from experimentally induced skin irritation.

Perrenaud et al. (38) conducted a double-blind cross-over study comparing a new registered BC containing 5% aluminum chlorhydrate as active ingredient with its vehicle in 21 apprentice hairdressers who are frequently exposed to repeated shampooing and hair care products for a period of two months.

The subjects were randomly assigned into two groups then each subject was given identical 50-g tubes at the onset of the study, after two weeks, and at the start of the second phase. The contents of the tubes were unknown to the investigators and subjects. The participants recorded their daily comments. Evaluation of the creams' efficacy included (i) clinical scores (dryness, redness, and breaks rated as 0 = none to 3 = maximum) assessed by the researchers; (ii) biometric measurements using evaporimeter, corneometer, and chromameter; and (iii) recording of subjective opinions. Result for clinical evaluation showed low scores—nearly everyone had a "0" or "1" score. Only corneometric values showed a significant difference, that is, the scores for the control group were significantly ( $p < 0.01$ ) higher than the test product.

De Paépe et al. (39) investigated the beneficial effects of a skin tolerance-tested moisturizing cream on the barrier function in experimentally elicited irritant and allergic CD in 24 white female volunteers. Skin compatibility tests with the raw cosmetic materials and the final test product were initially performed in a large population to verify that the test product was well tolerated. Irritant CD was elicited using 1.25% SLS patch tested for 24 hours on the volar forearms of 12 white female volunteers in two sites (one site for treatment with the test cream, while the other site left untreated). A third site was patch tested with filter paper soaked in pure water. Following patch removal, the forearms were washed, and application of 0.03 mL test cream was initiated the next day, twice daily for 14 consecutive days. There were significant ( $p < 0.05$ ) decreases in transepidermal water loss (TEWL) values of the treated site when compared to the untreated site on days 3, 8, and 15. Allergic CD was elicited using nickel-mediated contact allergy patch (CAP) test in another 12 white female volunteers with well-established histories of nickel (Ni) contact allergies. Two patches contained 0.3 mL of 5% nickel sulfate in petrolatum and a third patch contained 0.3 mL of physiological serum (0.9% NaCl) served as control. Patches were removed after 48 hours and test sites were cleaned with dry tissue, then 0.3 mL of the test cream was applied on the test sites 2× a day for four consecutive days. Results revealed that a significant ( $p < 0.05$ ) decrease in TEWL values of the treated site when compared with the untreated site on days 3, 8, 15.

Diepgen et al. (40) investigated six skin care products (Locobase Pro cream, Debba Wet, Taktosan, Pluctect Dual, Locobase fatty cream, and Kerodex 71) for their compatibility with normal and diseased skin, as well as their efficacy as protective skin barriers in 40 healthy volunteers in a double-blind study. The chamber scarification test (33) was used to compare the test products with known positive (aqueous SLS 0.5%) and negative (paraffin oil) controls and to rank the irritancy potential of products in 20 healthy volunteers. Approximately 0.1 mL of each product was applied in the scarified normal skin of their flexor forearms of the participants using Finn Chambers®. Patches were removed after 23 hours (day 1) and read an hour later, and immediately before reapplication of the samples for days 2 and 3. Reactions were scored visually using a five-point scale ("0" = no reaction to "4" = confluent, severe redness with edema or bullae). Results revealed that out of the eight samples applied, Debba Wet had the highest sum of scores ("12") in five subjects, while positive control only reached a maximum score of "10" in three subjects. Both Debba Wet and SLS 0.5% were considerably more irritating ( $p < 0.0001$ ) than the other test products. The ranking of the test products was as follows: Deba Wet (score

average = 11) ≥ SLS 0.5% aqueous (score average = 7.4) ≥ Taktosan cream (score average = 3.7) ≥ Locobase fatty cream (score average = 3.3) ≥ Kerodex 71, Pluctect Dual, Locobase Pro cream, and paraffin oil (score average = 2.2–3.0). On the other hand, the repeated-exposure short-time occlusive irritation test (ROIT) was used to assess the efficacy of the six products and yellow Vaseline as protective skin barriers in another 20 healthy volunteers. ROIT involved multiple short application times using low concentration of irritants. Aqueous SLS 0.5% was used as the irritant and was patch tested using Large Finn Chambers on the volar forearms of the subjects. For each site, the following were applied: irritant alone, water alone, one was left blank, while the rest of the sites were first pretreated with the seven test creams 10 minutes prior to irritant application. The placing of the test products was changed from person to person according to a rotation system. The whole procedure was repeated every 3 to 3.5 hours for three consecutive days. Parameters utilized were TEWL (measured by Tewameter TM 210), erythema (measured by ChromaMeter CR 300), and clinical visual scoring (numerical scale: "0" = no reaction to "3" = pronounced erythema and edema, extensive scaling, possibly vesicles, bullae, pustules, and/or pronounced crusting). Final results for the comparison of delta TEWL values between the test areas and the untreated sites showed significantly ( $p < 0.05$ ) increased values for Vaseline, Taktosan, and Debba Wet. There was no significant difference among the TEWL values for Locobase Pro cream, Pluctect Dual, Locobase fatty cream, and Kerodex 71 when compared with normal skin. The increase in TEWL values were not significant ( $p > 0.05$ ) between SLS-exposed sites and pretreated sites. Clinically, treatment with the SLS increased the visual scores. Likewise, Vaseline, Taktosan, and Debba Wet did not offer protection from skin irritation.

Modak et al. (41) demonstrated that the use of topical formulation with zinc gel delayed or prevented latex sensitivity in 22 volunteers known to have mild to moderate latex intolerance. Three cubic centiliter (cc) of both zinc gel formulation and placebo creams were applied to the subjects divided into three groups: group A (zinc gel formulation applied on the right hand and placebo cream on the left hand in 10 subjects who used powdered latex gloves); group B (no cream on the right hand and zinc gel formulation on the left hand in another 10 subjects who used powdered latex gloves); and group C (no cream on the right hand and zinc gel formulation on the left hand in 2 volunteers who used powder-free latex gloves). Latex gloves were then worn by the subjects until they perceived discomfort or until three to four hours that had passed if without symptoms. Investigators rated the subjects using numerical scale: "0" = no visible reaction to "3" = severe itching, redness, and papules all over the hand within 30 minutes. Results showed that zinc gel formulation protected 21 out of 22 volunteers from latex sensitivity. Only one subject had a score of "1" belonging to group A. Additionally, the investigators extracted latex proteins from the gloves, and treated with zinc gel formulation diluted in distilled water. Results revealed that zinc gel formulation-treated latex proteins decreased (mean = 0.28) as compared with the untreated ones (mean = 1.14), by ~74%. Lastly, zinc gel formulation was compared with three other creams and a control (no cream applied) to evaluate its barrier efficacy. Zinc gel formulation proved superior among the three creams.

Rosado et al. (42) utilized dynamic methods to assess the efficacy of a urea containing moisturizing cream to the lower



Table 5.1 Brief Data of Recent Experiments of BC

In vitro		Models		Irritants or allergens or penetrants		BC	Evaluations by	Efficacy	Authors and references
	In vivo	Animals or humans							
Human skin				Dyes (eosin, methylviolet, oil red O)	16 BC		Amount of dyes in the epidermis	Various percent protection effects.	Treffel et al. (22)
Human skin		Nickel-sensitive patients		Nickel disk	Ethylenediaminetetraacetate gels		Nickel content	Significantly reduced the amount of nickel in the epidermis in vitro, and significantly reduced positive reactions in vivo.	Fullerton and Menne (23)
Human skin				[ <sup>35</sup> S]-SLS	3 Quaternium-18 bentonite gels		Amount of [ <sup>35</sup> S]-SLS	Percent protection effect was 88%, 81% and 65%, respectively.	Zhai et al. (24)
Pig ears and semipermeable silicone membranes				Neurotoxic OP	3 creams		Cumulative amount of OP	The perfluorinated compounds-based cream have a broader spectrum of efficacy.	Millerioux et al. (25)
		Guinea pigs		N-hexane, trichlorethylene, toluene	3 water-miscible creams		Morphological assessment	Limited protective effects.	Lachapelle et al. (31)
		Guinea pigs and humans		SLS, sodium hydroxide, toluene, lactic acid	Several BC		Various bioengineering techniques	Some of them suppressed irritation, some failed.	Frosch et al. (1, 15, 32,33)
		Humans		Dyes (methylene blue and oil red O)	3 BC		Amount of dye penetrating into strips	2 of them exhibited effectiveness, 1 enhanced cumulative amount of dye.	Zhai and Maibach (2)
		Humans		SLS, ammonium hydroxide (NH <sup>4</sup> OH) and urea, Rhus	Several protectants		Clinical scores	Most of them suppressed the SLS irritation and Rhus allergic reaction, failed to NH <sup>4</sup> OH and urea irritation.	Zhai et al. (5)
		Humans		Self-application of BC	An oil-in-water emulsion		Fluorescence technique	Self-application of BC was incomplete.	Wigger-Alberti et al. (34)
		Humans		Skin with dermatitis	Hydrogel barrier/repair creams		Questionnaire	62% of the subjects' and 75% of the investigators' assessments favored the BC.	Draelos (35)
		Humans		Antiseptics, gloves	Novel BC and cream with oil-containing lotion		Clinical scores	Both creams offered protection.	McCormick et al. (36)
		Humans		SLS on days 15–25	5% dexpanthenol		Various bioengineering techniques and photography	Capable to protect skin in experimentally elicited irritation.	Biro et al. (37)

Humans	Shampoos and other hair care products	5% aluminum chlorhydrate	Clinical scores, bioengineering techniques, subjects' personal assessment	Very little difference between BC and its vehicle.	Perrenoud et al. (38)
Humans	SLS and nickel	Skin tolerance–tested moisturizing cream	TEWL	Significant decrease in TEWL values of treated sites.	De Paepe et al. (39)
Ears of the domestic white pigs	VX chemical warfare	AG-7 (70% w/w Fomblin™ HC/R plus 30% w/w lubricant grade polytetrafluoroethylene)	Acetylcholinesterase, pupil diameter	Treated groups survived the 3-hr exposure; Pretreatment of BC lowered the amount of VX penetration.	Chilcott et al. (12)
Humans	SLS	6 skin care products	Chamber scarification test and repeated-exposure short-time occlusive irritation test	Debba Wet and SLS were more irritating; Vaseline, Taktosan, and Debba Wet did not offer protection from skin irritation.	Diepgen et al. (40)
Humans	Latex gloves	Topical formulation with zinc	Clinical scores	Protected 95% of subjects; decreased dissolved latex proteins by ~74%.	Modak et al. (41)
Humans	Severe dry skin	A urea containing cream	Plastic occlusion stress test	BC improved the water dynamic balance and skin barrier.	Rosado et al. (42)
Pig skin	Patent Blue V	Quantify stratum corneum penetration; and comparison of 3 BC for efficacy	Penetration behavior of Patent Blue V	Higher concentrations of the penetrant yielded excess amount recovered, and Vaseline and beeswax are effective BC.	Teichmann et al. (43)

Abbreviations: BC, barrier creams; SLS, sodium lauryl sulfate; OP, organophosphorus compounds; TEWL, transepidermal water loss.

leg of 12 volunteers with severe dry skin. After two weeks of application with test BC, a plastic occlusion stress test (POST) was performed in the treated and control untreated site and a mathematical model was adjusted to the resulting desorption curves. Results indicate that, after treatment of the skin with the cream for two weeks, statistically different kinetic parameters are obtained in the treated site, which suggests an improvement in the water dynamic balance and skin barrier. They concluded that the method has enough sensitivity to assess in vivo the effect of moisturizers on human skin, and also that this evaluation can be performed in a shorter period than that required by the regression method.

## IN VITRO AND IN VIVO METHODS

Teichmann et al. (43) investigated the reservoir and barrier functions of the skin in two study designs because the former function is dependent on the latter function. Study design A was carried out in six healthy volunteers according to the method described by Teichman et al. (44) and to a pig skin, to quantify stratum corneum penetration. Patent Blue V ( $C_{54}H_{26}CaN_4O_{14}S_4$ ) in water (the penetrant) was applied to the human skin in increasing amounts—10 and 40  $\mu\text{g}/\text{cm}^2$  of the 0.5% concentration, and 40  $\mu\text{g}/\text{cm}^2$  of the 2% concentration. After one hour, substances were wiped to avoid occlusion, and then tape stripping was performed on the fifth hour. Results for the 10  $\mu\text{g}/\text{cm}^2$  of the 0.5% concentration revealed the amount of stratum corneum extracted were  $5.1 \pm 1.25 \mu\text{g}/\text{cm}^2$ —no penetrant was recovered, that is, no excess amount developed. However, after the applications of 40  $\mu\text{g}/\text{cm}^2$  of the previous concentration and the 2% concentration, ( $21.5 \pm 1$  and  $27.7 \pm 1.5 \mu\text{g}/\text{cm}^2$  of extracted stratum corneum, respectively), excess amounts of the penetrant were recovered ( $6.7 \pm 2.8$  and  $27.7 \pm 1.5 \mu\text{g}/\text{cm}^2$ , respectively). The same procedure was performed on the porcine skin to obtain a histological diagnosis and showed that a large amount of Patent Blue V was located on the skin surface and the upper parts of the stratum corneum, and greater amounts were also found in the furrows. Study B was performed in another six healthy volunteers and investigated three BCs (commercial BC, beeswax, Vaseline) using the penetration behavior of Patent Blue V in water in the different BC-pretreated skin, and one untreated site by tape stripping. Results revealed that the commercial BC did not demonstrate barrier function—similar to the untreated site ( $p > 0.05$ ); while beeswax and Vaseline were significant ( $p < 0.05$ ) in their efficacy of barrier function.

Chilcott et al. (12) conducted an in vivo and in vitro study evaluating the efficacy of a BC (70% w/w Fomblin<sup>TM</sup> HC/R and 30% w/w lubricant grade polytetrafluoroethylene) versus chemical warfare agent in domestic white pigs. The in vivo study involved 18 pigs prepared as previously described (13) and divided into three groups: control group (no agent, no BC), positive control group (with agent, no BC) and pretreated group (application of agent 15 minutes post application of the BC). Where appropriate, 40  $\mu\text{L}$  of the BC and  $^{14}\text{C}$ -VX (~6-hour 2LD<sub>50</sub>) were applied over the inner ear of the animals. Indicators of mortality included a decrease in serum acetylcholinesterase (AChE) and a large pupil diameter. Animals in the control and BC-treated groups survived the three-hour exposure period, while five out of the six animals in the positive control group died after a mean time of  $65 \pm 13$  minutes. Correspondingly, there was a significant ( $p < 0.05$ ) decline in serum AChE while there was no significant ( $p > 0.05$ ) change in pupil diameter. On

the other hand, the in vitro study involved the contralateral (unexposed) ears of the post mortem pigs from the in vivo study. Twelve pig skins were placed in Franz-type glass diffusion cells filled with PBS (phosphate buffered saline) receptor chamber fluid. Twenty-five point four microliters (25.4  $\mu\text{L}$ ) of the BC was applied onto the skin using a 25- $\mu\text{L}$  positive displacement pipette, and was spread using a piston from a 1-mL syringe as previously described (13) to give a nominal thickness of 0.1 mm. Each diffusion cell was subjected to the same decontamination procedure similar to the in vivo study. Pretreatment with the BC significantly ( $p < 0.05$ ) decreased skin surface spreading of  $^{14}\text{C}$ -VX and lowered the total amount penetrated, similar to the in vivo study results. On the other hand, the three dose parameters (unabsorbed, skin, receptor/systemic) were significantly ( $p < 0.05$ ) different except for one parameter (total amount absorbed) between the two systems.

Recent BC experiments are summarized in Table 5.1.

## CONCLUSIONS

Some BC reduce CD under experimental conditions. But, inappropriate BC application may enhance irritation rather than benefit. To achieve the optimal protective effects, BC should be used with careful consideration based on a specific exposure conditions; also, the proper use of BC should be instructed.

In vitro methods are simple, rapid, and safe, and are recommended in screening procedure for BC candidates. With radiolabeled methods, we may determine the accurate protective and penetration results even in the lower levels of chemicals because of the sensitivity of radiolabeled counting when BC are to be evaluated. Animal experiments may be used to generate kinetic data because of a closer similarity between humans and some animals (pigs and monkeys, etc.) in percutaneous absorption and penetration for some compounds. But no one animal, with its complex anatomy and biology, will simulate the penetration in humans for all compounds. Therefore, the best estimate of human percutaneous absorption is determined by in vivo studies in humans. The histological assessments may define what layers of skin are damaged or protected, and may provide the insight mechanism of BC. Noninvasive bioengineering techniques may provide accurate, highly reproducible, and objective observations in quantifying the inflammation response to various irritants and allergens when BC are to be evaluated that could assess subtle differences to supplement traditional clinical studies.

To validate these models, well controlled field trials are required to define the relationship of the model to the occupational setting. Finally, the clinical efficacy of BC should be assessed in the workplace rather than in experimental circumstance. A recent review of evaluating the efficacy of BC provides additional insights (45).

## REFERENCES

1. Frosch PJ, Schulze-Dirks A, Hoffmann M, et al. Efficacy of skin barrier creams. (I). The repetitive irritation test (RIT) in the guinea pig. *Contact Dermatitis* 1993; 28:94–100.
2. Zhai H, Maibach HI. Effect of barrier creams: human skin in vivo. *Contact Dermatitis* 1996; 35:92–96.
3. Lachapelle JM. Efficacy of protective creams and/or gels. In: Elsner P, Lachapelle JM, Wahlberg JE, et al., eds. *Prevention of Contact Dermatitis*, *Curr Probl Dermatol*. Basel: Karger, 1996:182–192.
4. Zhai H, Maibach HI. Percutaneous penetration (Dermatopharmacokinetics) in evaluating barrier creams. In: Elsner P, Lachapelle

- JM, Wahlberg JE, et al., eds. Prevention of Contact Dermatitis, *Curr Probl Dermatol*. Basel: Karger, 1996:193–205.
5. Zhai H, Willard P, Maibach HI. Evaluating skin-protective materials against contact irritants and allergens. An in vivo screening human model. *Contact Dermatitis* 1998; 38:155–158.
  6. Wigger-Alberti W, Elsner P. Do barrier creams and gloves prevent or provoke contact dermatitis? *Am J Contact Dermatitis* 1998; 9:100–106.
  7. Zhai H, Maibach HI. Barrier creams. In: Zhai H, Wilhelm K-P, Maibach HI, eds. *Dermatotoxicology*. 7th ed. Florida: CRC Press, 2008:299–302.
  8. Birmingham D. Prevention of occupational skin disease. *Cutis* 1969; 5:153–156.
  9. Mathias CG. Prevention of occupational contact dermatitis. *J Am Acad Dermatol* 1990; 23:742–748.
  10. Estlander T, Jolanki R, Kanerva L. Rubber glove dermatitis: a significant occupational hazard-prevention. In: Elsner P, Lachapelle JM, Wahlberg JE, et al., eds. *Prevention of Contact Dermatitis*, *Curr Probl Dermatol*. Basel: Karger, 1996:170–176.
  11. Amin S, Maibach HI. Immunologic contact urticaria definition. In: Amin S, Lahti A, Maibach HI, eds. *Contact Urticaria Syndrome*. Boca Raton: CRC Press, 1997:11–26.
  12. Chilcott RP, Dalton CH, Hill I, et al. Evaluation of a barrier cream against the chemical warfare agent VX using the domestic white pig. *Basic Clin Pharmacol Toxicol* 2005; 97:35–38.
  13. Chilcott RP, Dalton CH, Hill I, et al. Clinical manifestations of VX poisoning following percutaneous exposure in the domestic pig. *Hum Exp Toxicol* 2003; 22:255–261.
  14. Goh CL. Cutting oil dermatitis on guinea pig skin. (I). Cutting oil dermatitis and barrier cream. *Contact Dermatitis* 1991; 24:16–21.
  15. Frosch PJ, Schulze-Dirks A, Hoffmann M, et al. Efficacy of skin barrier creams. (II). Ineffectiveness of a popular “skin protector” against various irritants in the repetitive irritation test in the guinea pig. *Contact Dermatitis* 1993; 29:74–77.
  16. Frosch PJ, Kurte A, Pilz B. Biophysical techniques for the evaluation of skin protective creams. In: Frosch PJ, Kligman AM, eds. *Noninvasive Methods for the Quantification of Skin Functions*. Berlin: Springer-Verlag, 1993:214–222.
  17. Sadler CGA, Marriott RH. The evaluation of barrier creams. *Br Med J* 1946; 23:769–773.
  18. Suskind RR. The present status of silicone protective creams. *Ind Med Surg* 1955; 24:413–416.
  19. Langford NP. Fluorochemical resin complexes for use in solvent repellent hand creams. *Am Ind Hyg Assoc J* 1978; 39:33–40.
  20. Reiner R, Roßmann K, Hoodonk CV, et al. Ointments for the protection against organophosphate poisoning. *Arzneim-Forsch/Drug Res* 1982; 32:630–633.
  21. Loden M. The effect of 4 barrier creams on the absorption of water, benzene, and formaldehyde into excised human skin. *Contact Dermatitis* 1986; 14:292–296.
  22. Treffel P, Gabard B, Juch R. Evaluation of barrier creams: an in vitro technique on human skin. *Acta Derm Venereol* 1994; 74:7–11.
  23. Fullerton A, Menne T. In vitro and in vivo evaluation of the effect of barrier gels in nickel contact allergy. *Contact Dermatitis* 1995; 32:100–106.
  24. Zhai H, Buddrus DJ, Schulz AA, et al. In vitro percutaneous absorption of sodium lauryl sulfate (SLS) in human skin decreased by quaternium-18 bentonite gels. *In Vitro Mol Toxicol* 1999; 12:11–15.
  25. Millerioux J, Cruz C, Bazire A, et al. Evaluation of in vitro tests to assess the efficacy of formulations as topical skin protectants against organophosphorus compounds. *Toxicol In Vitro* 2009; 23:127–133.
  26. Schwartz L, Warren LH, Goldman FH. Protective ointment for the prevention of poison ivy dermatitis. *Public Health Rep* 1940; 55:1327–1333.
  27. Lupulescu AP, Birmingham DJ. Effect of protective agent against lipid-solvent-induced damages. Ultrastructural and scanning electron microscopical study of human epidermis. *Arch Environ Health* 1976; 31:29–32.
  28. Mahmoud G, Lachapelle JM, Neste DV. Histological assessment of skin damage by irritants: its possible use in the evaluation of a ‘barrier cream.’ *Contact Dermatitis* 1984; 11:179–185.
  29. Mahmoud G, Lachapelle JM. Evaluation of the protective value of an antisolvent gel by laser Doppler flowmetry and histology. *Contact Dermatitis* 1985; 13:14–19.
  30. Mahmoud G, Lachapelle JM. Uses of a guinea pig model to evaluate the protective value of barrier creams and/or gels. In: Maibach HI, Lowe NJ, eds. *Models in Dermatology*. Basel: Karger, 1987:112–120.
  31. Lachapelle JM, Nouaigui H, Marot L. Experimental study of the effects of a new protective cream against skin irritation provoked by the organic solvents n-hexane, trichlorethylene and toluene. *Dermatosen* 1990; 38:19–23.
  32. Frosch PJ, Kurte A, Pilz B. Efficacy of skin barrier creams. (III). The repetitive irritation test (RIT) in humans. *Contact Dermatitis* 1993; 29:113–118.
  33. Frosch PJ, Kurte A. Efficacy of skin barrier creams. (IV). The repetitive irritation test (RIT) with a set of 4 standard irritants. *Contact Dermatitis* 1994; 31:161–168.
  34. Wigger-Alberti W, Maraffio B, Wernli M, et al. Self-application of a protective cream. Pitfalls of occupational skin protection. *Arch Dermatol* 1997; 133:861–864.
  35. Draelos ZD. Hydrogel barrier/repair creams and contact dermatitis. *Am J Contact Dermatitis* 2000; 11:222–225.
  36. McCormick RD, Buchman TL, Maki DG. Double-blind, randomized trial of scheduled use of a novel barrier cream and an oil-containing lotion for protecting the hands of health-care workers. *Am J Infect Control* 2000; 28:302–310.
  37. Biro K, Thaci D, Ochsendorf FR, et al. Efficacy of dexapanthenol in skin protection against irritation: a double-blind, placebo-controlled study. *Contact Dermatitis* 2003; 49:80–84.
  38. Perrenoud D, Gallezot D, van Melle G. The efficacy of a protective cream in a real-world apprentice hairdresser environment. *Contact Dermatitis* 2001; 45:134–138.
  39. De Paépe K, Hachem JP, Vanpee E, et al. Beneficial effects of a skin tolerance-tested moisturizing cream on the barrier function in experimentally-elicited irritant and allergic contact dermatitis. *Contact Dermatitis* 2001; 44:337–343.
  40. Diepgen TL, Andersen KE, Schnetz E, et al. Dual characteristics of skin care creams evaluated by two in-vivo human experimental models. *J Toxicol Cutaneous Ocul Toxicol* 2003; 22:157–167.
  41. Modak S, Gaonkar TA, Shitre M, et al. A topical cream containing a zinc gel (allergy guard) as a prophylactic against latex glove-related contact dermatitis. *Dermatitis* 2005; 16:22–27.
  42. Rosado C, Pinto P, Rodrigues LM. Assessment of moisturizers and barrier function restoration using dynamic methods. *Skin Res Technol* 2009; 15:77–83.
  43. Teichmann A, Jacobi U, Wailber E, et al. An in vivo model to evaluate the efficacy creams on the level of skin penetration to chemicals. *Contact Dermatitis* 2006; 54:5–13.
  44. Teichmann A, Jacobi U, Weigmann HJ, et al. Reservoir function of the stratum corneum: development of an in vivo method to quantitatively determine the stratum corneum reservoir for topically applied substances. *Skin Pharmacol Physiol* 2005; 18:75–80.
  45. Zhai H, Maibach HI. Evaluating efficacy of barrier creams: in vitro and in vivo models. In: Zhai H, Wilhelm K-P, Maibach HI, eds. *Dermatotoxicology*. 7th ed. Florida: CRC Press, 2008:621–626.

# Using the behind-the-knee (BTK) test to evaluate lotion transfer from products to skin

Miranda A. Farage

## INTRODUCTION

Manufacturers of consumer products consistently look for new ways in which their products may provide benefits to the consumer. A growing trend for absorbent consumer products is to incorporate lotions and emollients on the surface to improve overall consumer comfort during product use. There are a number of examples of such products currently on the market. Facial tissues impregnated with lotion have been shown to facilitate the healing of redness and dryness that may occur to the area around the nose as a result of repeated wiping when suffering from a cold or allergy (1). Benefits of topical administration of skin protectants from baby diaper topsheets clinically reduced skin erythema and skin barrier damage in infants (2). Petrolatum emollient impregnated in diapers reduced skin surface roughness, skin erythema and diaper dermatitis compared with identical diapers without emollient (3,4). A combined zinc oxide/petrolatum (ZnO/Pet) formulation was demonstrated to actually protect skin from damage when subsequently challenged with a model irritant (0.5% sodium lauryl sulfate) under 24-hour occlusive patch (5). The protective effects of this technology also provide advantages in feminine protection products. Preliminary clinical studies in nonmenstruating women showed that the ZnO/Pet lotion effectively transferred to vulvar skin during pad wear in a dose and time-dependent manner. The safety and efficacy of the emollient-impregnated pads was subsequently confirmed in clinical studies (6).

Lotion transfer is primarily a surface phenomenon. Molecules of lotion on the surface of the product transfer to the surface of the skin. Once on the skin surface, the lotion acts as a barrier to moisture loss and provides lubrication (7). It follows that, for lotion technologies to provide benefits for absorbent products, the lotion must first be able to transfer to the skin surface. While this point may seem obvious, it provides a unique challenge when dealing with absorbent products. After all, the main function of the product is to absorb material, not release it to the skin. A reliable means to measure the relative quantities of various lotions which transfer from absorbent products, and the potential effects of other product characteristics, is key in the development of lotion-containing products that will provide skin benefits.

We have developed a modification of the behind-the-knee (BTK) protocol to evaluate lotion transfer from emollient-coated menstrual pads. The BTK protocol using the popliteal fossa as a test site was originally developed to evaluate both the inherent chemical irritation, and the potential for mechanical irritation of substrates and products that come into prolonged or repeated contact with the skin (8). However, we have found that this method can effectively measure the amount of lotion

formulations that transfer to the skin with greater reliability than measurements conducted in the course of clinical in-use studies (9). In a series of studies, we examined the influence of various aspects of menstrual pad construction and chemical composition on the transfer of lotion to the skin.

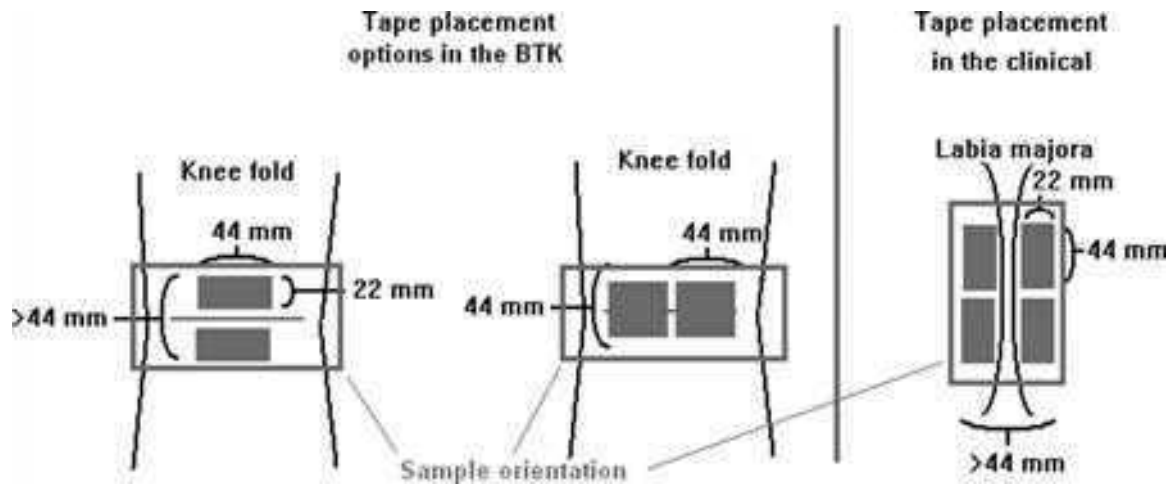
It is important to note that this method measures transfer of lotion from the menstrual pads, and is capable of detecting small differences in the amount of lotion transferred. This model is *not* a measure of efficacy. In fact, in our experience, consumers do not notice small differences in the amount of lotion transferred, nor do we see differences in efficacy with small changes in the amount transferred. However, when making decisions about improvements or other changes to the product which may involve considerable expense and resources, having a sensitive measure of lotion transfer is invaluable in guiding the product development process toward the most cost-effective efforts.

## METHODS

Both the BTK and clinical in-use protocols were conducted in accordance with the Declaration of Helsinki, and were reviewed and accepted by the Institutional Review Board of the research facility (10). All subjects reviewed and signed an informed consent prior to the study. Subjects were excluded from participation in the study if they had a history of sensitivity to skin tapes, bandages or adhesives, if they had any condition in the test area which would prevent the collection tapes from adhering to the skin (i.e., piercings, wounds, etc.), or if they were currently menstruating.

## BTK Protocol

The BTK protocol has been described previously (7,9). Panels of healthy adults were enrolled for participation. Subjects were instructed to refrain from using lotions, creams, or any other skin preparation on the area of the skin to which product was to be applied. Subjects with preexisting irritation or discomfort in the area behind the knee or leg varicosities were excluded. To absorb lotion transfer, two sections of waterproof, thin film dressing tape (Tegaderm™ tape, 3M™, St. Paul, Minnesota, U.S.) were applied on the popliteal fossa of each leg, as in the examples shown in Figure 6.1. Test pad samples were placed horizontally and held in place on the popliteal fossa by an elastic knee band of the appropriate size. Samples were placed randomly on the right or left test sites. Following application of the pads, subjects left the test facility and participated in normal daily activities. After three hours, the test sample was removed, and one piece of collection tape was removed from each test site for analysis. A fresh test product was applied for



**Figure 6.1** Diagram of tape and sample placement. In the BTK study, two tape placement options are shown in which sections of sterile, waterproof, thin film dressing tape are applied on the popliteal fossa of each leg. Test samples are applied directly on top of the collection tape. In the clinical study, four sections (22 mm × 44 mm) of the thin film dressing tape were applied to each side of the labia majora (two per side) oriented parallel to the vaginal opening. *Abbreviation:* BTK, behind-the-knee.

three more hours (i.e., a total of six hours of application), following which, the second collection tape was removed and analyzed.

### Clinical In-Use Protocol

The clinical in-use protocol has also been described previously (9). Healthy, adult, nonmenstruating female subjects, aged 18 to 55, were enrolled. At least 24 hours prior to tape application and pad wear, subjects were required to discontinue the use of all lotions, ointments, creams, powders, soaps/body washes, feminine wipes or toilet paper with lotion in the vulvar area. The subject was asked not to bathe or shower during the 24-hour periods when the collections tapes were in place.

The subjects were randomized into three groups of 12 each, and each group was assigned to wear two of the six test products (i.e., feminine protection pads with lotion) in random order. A crossover design with a 24-hour washout period was used for the pairwise comparisons so that each subject served as her own control. Consequently, the study had two phases, each involving 24 hours of pad wear time with one of the two comparison products to which the subject was assigned.

Immediately prior to the start of phase one, pubic hair present on the site of application was clipped by the study technician. Four sections (22 mm × 44 mm) of the thin film dressing tape were applied to each side of the labia majora (two per side) oriented parallel to the vaginal opening (Fig. 6.1). Panties and test pads were dispensed, and the subjects wore the pads for three hours. During this time, subjects participated in normal activities of daily living. After three hours of wear, two of the four tape sections (in random order) were removed for determining lotion transfer. An activity log for the three hour wear time was completed. After removal of two sections of collection tape, the same fresh test product was reapplied as needed by the test subject for the remainder of the total 24-hour test period (approximately 21 additional hours of wear time). Subjects were given enough test products so that they could

change pads at approximately three- to five-hour intervals and once after overnight wear during the test period. The subjects kept a test product use log to record the times when each test product was removed, and the total number of pads used. After the pads had been worn for a total of 24 hours, subjects returned to the test facility, and the two remaining sections of collection tape were removed, to complete phase one. Following the 24-hour washout period, the entire process was repeated for phase two using a different product.

### Test Products

Menstrual pads are constructed of a surface layer (topsheet), an absorbent core, and a moisture-impermeable backing (11–13). The topsheets are made from nonwoven polyethylene-based or polypropylene-based copolymeric fabrics, perforated polyethylene films, or some combination of these. The absorbent core may consist of cellulose fluff pulp, or absorbent gel materials (AGM) designed to hold larger volumes of fluid. In addition, some menstrual pads contain emollients on the surface to reduce skin irritation during use. These are applied in stripes on the topsheet that may vary in number, position and size.

For these studies, two series of products were tested. Key characteristics are provided in Table 6.1. In the first series (product codes 1 through 7), identically constructed menstrual pads were used, with the same absorbent core, topsheet, lotion formulation and configuration of the stripes. The only difference was the amount of lotion applied to the surface of the pad. The second series was designed to test the potential influence of differences in pad construction, that is, the type of absorbent core and the configuration of the lotion applied to the pad. This series was also evaluated in a clinical in-use study for comparison.

### Lotion Measurement

Lotion was quantified by gas chromatography with flame ionization detection. The thin film dressing tapes containing lotion from either the BTK or clinical in-use wear protocols were

**Table 6.1** Characteristics of Test Products

Test product code	Absorbent core	Pad thickness (mm)	Amount of lotion		Number of 5-mm stripes of lotion
			Total on pad (mg/pad)	Amount per unit area (mg/cm <sup>2</sup> )	
Test product series I					
1	Cellulose	7	0.8	0.0	5
2	Cellulose	7	11.2	0.3	5
3	Cellulose	7	23.3	0.6	5
4	Cellulose	7	33.0	0.9	5
5	Cellulose	7	41.8	1.1	5
6	Cellulose	7	53.3	1.4	5
7	Cellulose	7	62.0	1.7	5
Test product series II					
Q	Cellulose	9	57.0	1.1	7
E	Cellulose	6	57.0	1.7	6
S	Cellulose	7	63.7	1.7	5
K	AGM	2	30.1	1.4	4
B	AGM	2	33.9	1.0	6
C	AGM	2	40.0	1.2	6

*Note:* The amount of lotion on each pad (mg/pad) was determined by gas chromatography with flame ionization detection. It is also expressed as the amount of lotion per unit area of the lotion-containing stripes (mg/cm<sup>2</sup>). For all products, the topsheets were made of polypropylene/polyethylene nonwoven fabric, and the lotion was a petrolatum based formulation.

*Abbreviation:* AGM, absorbent gel materials.

extracted for 30 minutes on a wrist action shaker using 10 mL of diluent. The extracts were passed through a 0.45- $\mu$ m filter (13-mm Acrodisc<sup>®</sup> Syringe Filters with GHP Membrane, Pall Corporation, East Hills, New York, U.S.). Samples and standards were then passed through a gas chromatographic column (a constant flow of 1.5 mL/min, initial oven at an initial temperature of 100°C, with an increase in temperature of 10°C/min up to 200°C, then 15°C/min up to the detector temperature of 325°C). Behenyl alcohol, a component of all the lotion formulations, served as a marker for lotion transfer. A calibration curve was generated on the basis of the three standard concentrations of behenyl alcohol (0.1, 0.05, and 0.004 mg/mL behenyl alcohol in 1 L of hexane containing 50 mg tricosanol). The mass of lotion transferred was determined from the mass of behenyl alcohol and its concentration in the of lotion formulation. Recovery was 90% to 110% on the basis of spiking of the collection tape.

### Statistical Analyses

For the BTK protocol, one-way ANOVAs were conducted for the three- and six-hour data. A two-way ANOVA was used to compare time (two measurements), treatment (six pads), and their interaction.

For the clinical in-use protocol, the 3- and 24-hour data were analyzed using two-way ANOVA, involving period (i.e., before and after crossover), treatment, and their interaction. For the combined data, a two-way ANOVA was used involving hour (i.e., 3- and 24-hour measurements) and treatment.

It should be noted that the clinical in-use study was a crossover design. Subjects used one test product in phase 1, and another product in phase two after a 24-hour "washout" period. To determine whether the washout period was effective, results were evaluated separately for the same products used during the first test period (phase 1) versus the second test period (phase 2). For two products (S and C), significant differences were found between the amount of lotion transferred when the products were used first (phase 1) compared

with the same products used second (phase 2), indicating the washout period was not effective. Therefore, the three-hour data were treated separately. For the 24-hour data, there were no significant differences for products tested during phase 1 versus phase 2. Therefore, the 24-hour data for both phases were combined.

## RESULTS

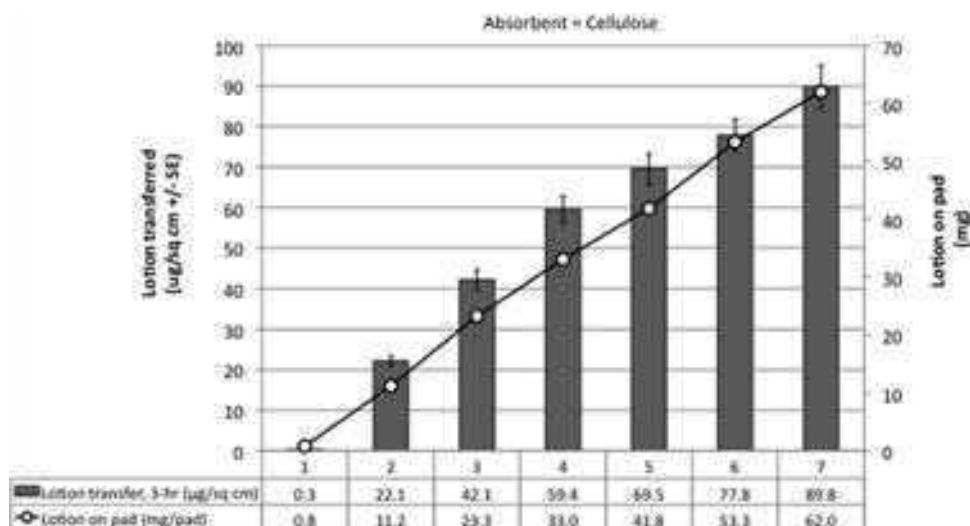
### Transfer as a Function of the Amount of Lotion on the Pad

As mentioned in the introduction of this chapter, lotion transfer is a surface phenomenon. There will be a range of concentrations of lotion on the pad where the amount of transferred lotion will increase proportionally. There will also be a range of concentrations where no additional lotion will transfer, that is, where the surface of the collection tape is full. In this range, additional lotion, either from an increase in concentration on the pad or from multiple applications of fresh pads, will not result in additional lotion transferred to the collection tape.

Test product series I was constructed to evaluate the effective concentration range for lotion transfer (Table 6.1). These menstrual pad samples were identical in every way except in the amount of lotion on the pads, which ranged from 0.8 to 62 mg/pad. As shown in Figure 6.2, for this range of lotion concentrations, the amount of lotion which transferred to the collection tape in the BTK after a three-hour application was directly proportional to the amount which was applied to the pad. The six-hour sample application showed similar results (data not shown). The data shown in Figure 6.2 indicate that the range of lotion quantities tested (0.8–62 mg/pad) resulted in effective transfer of the lotion to the surface in a linear fashion.

### Influence of the Absorbent Core on Lotion Transfer

The two basic options for absorbent cores have very different chemical and absorbent characteristics. Cellulose material



**Figure 6.2** Lotion transfer as a function of starting amount on pad. Lotion transfer from the first series of test products was evaluated using the behind-the-knee protocol. These test products were prepared with different amounts of lotion on the surface. In all other respects, the products were identical. The figure shows the amount of lotion transferred (in  $\mu\text{g}/\text{cm}^2$ ) compared with the starting amount of lotion on the pad (in mg/pad) for each of the test products. *Abbreviation:* SE, standard error.

absorbs by capillary action whereas AGM absorbs by ionic action. If the lotion is composed of nonpolar components, AGM will have a lower affinity for the lotion and, therefore, release it more easily. Thus, the type of absorbent core would be expected to influence the amount of lotion that will transfer from the product.

A second test product series was constructed to compare a number of product differences, including a comparison of the cellulose and AGM cores (Table 6.1). Because of the superior absorbent qualities of the AGM, the three AGM pads were only 2 mm thick, whereas those with cellulose cores ranged from 7 to 9 mm thick. The lotion concentrations and configuration differed. These products were tested in both the BTK and a clinical in-use study to measure lotion transfer.

In the BTK, pads with an AGM core transferred more lotion than those with the more traditional cellulose absorbent core. Figure 6.3A shows data from both the three- and six-hour collection. As shown, even though the cellulose pads had more lotion applied to the surface, they tended to transfer less lotion to the collection tapes than the AGM pads.

The clinical in-use study results showed a similar trend, although the data were less consistent (Fig. 6.3B). No particular trend was obvious at the three-hour collection point. However, after 24-hour exposure, the AGM pads released similar amounts of lotion compared with the cellulose pad, even though the starting amounts on the AGM pads were greatly reduced compared with the cellulose pads.

### Influence of Pad Thickness on Lotion Transfer

The most likely explanation for the results shown in Figure 6.3 are the chemical differences between the AGM and cellulose materials. However, an alternative possibility is that the AGM pads transfer more lotion because they are thinner. If this were the case, and thinner pads transfer lotion better, one would expect that the intermediate pads (i.e., pad E, 6 mm thick, and

pad S, 7 mm thick) would transfer more lotion than the thickest pad (pad Q, 9 mm). This was not the case, as shown in the Figure 6.4. Among the cellulose core products (S, Q, and E), the one with the most lotion on the pad to start (pad S with 63.7 mg lotion and a thickness of 7 mm) transferred directionally more lotion to the skin in both the BTK and clinical, although the differences were not statistically significant in either protocol. The thicker cellulose pad Q (9 mm) and the thinner cellulose pad E (6 mm) both transferred an amount that was directionally less than pad S, and roughly equivalent to each other.

### Influence of Lotion Configuration on Lotion Transfer

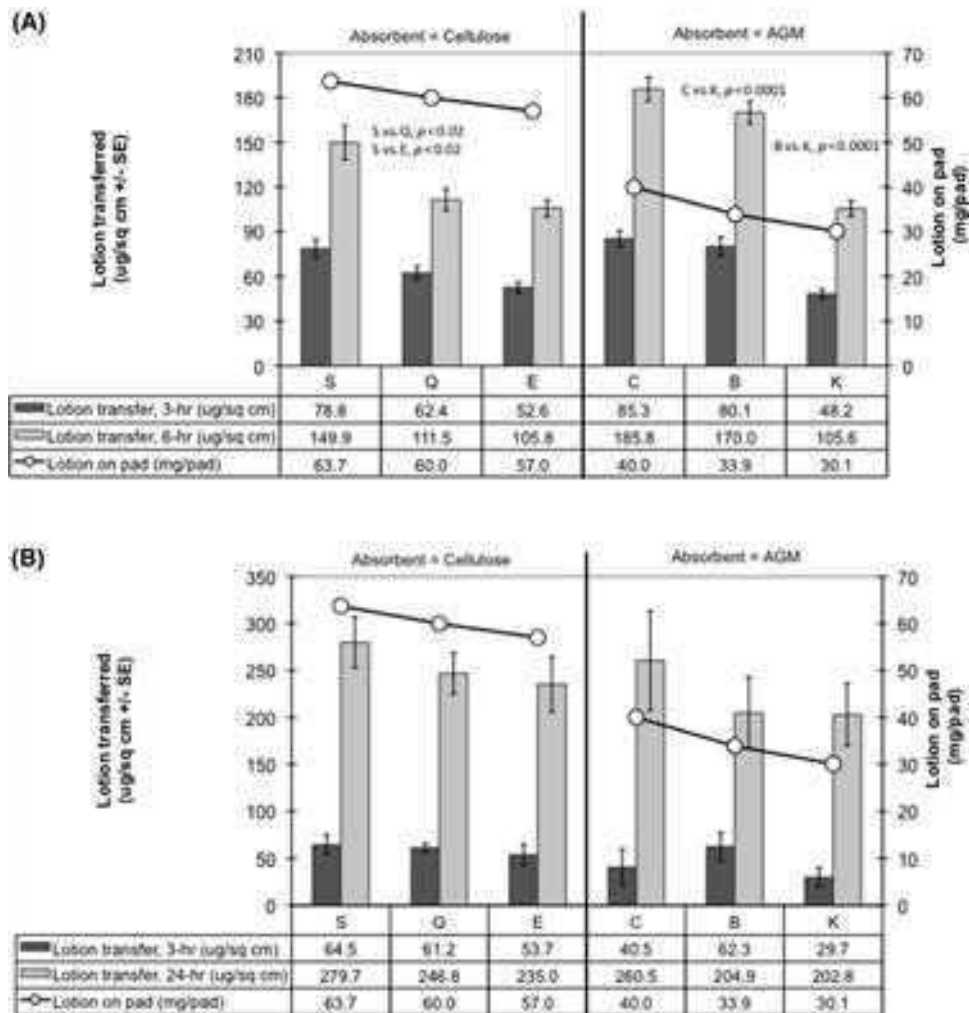
The amount of lotion transferred did not seem to be dependent on the configuration of the lotion on the pad in the series of products tested. These products had varying numbers of 0.5-cm-wide stripes, that is, from seven to four, yet the amount of lotion transferred did not vary directionally with the number of stripes for the group of products as a whole, nor when the cellulose (Q, E, and S) and AGM (C, B, and K) products were considered separately (Fig. 6.5).

### Lotion Transfer Efficiency BTK Protocol Vs. Clinical in-Use Protocol

The efficiency of lotion transfer for both test protocols was determined as a percentage of the entire lotion reservoir available for transfer (amount of lotion on pad in  $\mu\text{g}/\text{cm}^2$ ). These results are presented in Figure 6.6. With the cellulose pads, both methods resulted in the transfer of 3.0% to 5.8% of the total amount of lotion available on the pad (per unit area) to the collection tapes. For the AGM pads, the transferred ranged from 2.2% to 7.7%.

The transfer efficiency in the BTK protocol was higher than that of the clinical in-use protocol for all three AGM pads, and for the cellulose pad S. In fact, for pad C, the transfer was





**Figure 6.3** Lotion transfer as a function of absorbent material. Lotion transfer from the second series of test products was evaluated using the BTK and the clinical in-use protocols. The figure shows the amount of lotion transferred (in  $\mu\text{g}/\text{cm}^2$ ) compared with the starting amount of lotion on the pad (in  $\text{mg}/\text{pad}$ ) for both types of absorbent cores: cellulose and AGM. **(A)** Lotion transfer after three and six hours in the BTK protocol. Pairwise comparisons resulted in the significant differences shown. **(B)** Lotion transfer after 3 and 24 hours in the clinical in-use protocol. Pairwise comparisons resulted in no significant differences. (Only phase 1 of the crossover study is reported for the three-hour time point.) *Abbreviations:* AGM, absorbent gel materials; BTK, behind-the-knee; SE, standard error.

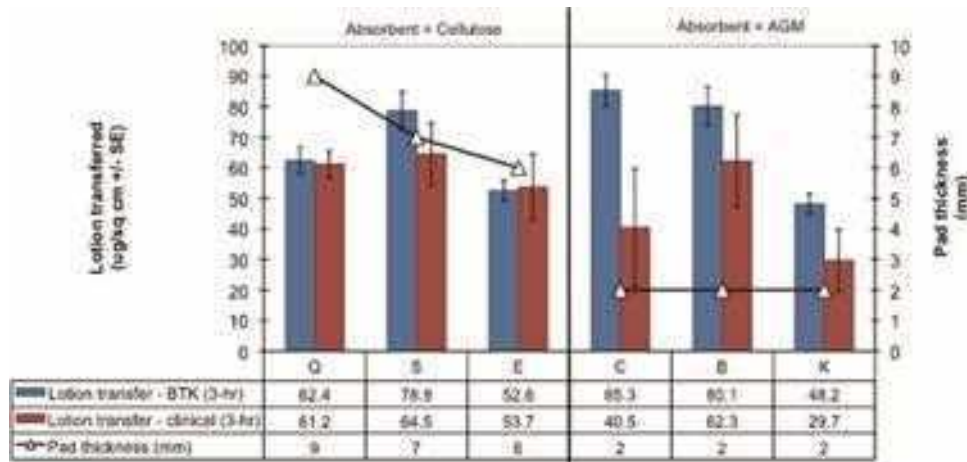
more than double in the BTK (7.0% compared with 3.3% in the clinical). For two cellulose pads, the transfer efficiency was similar for the two protocols (E and Q). Similar patterns were observed for the transfer efficiency at 6 hours for the BTK and 24 hours for the clinical (data not shown).

### Comparison of the Two Test Protocols: BTK Vs. Clinical

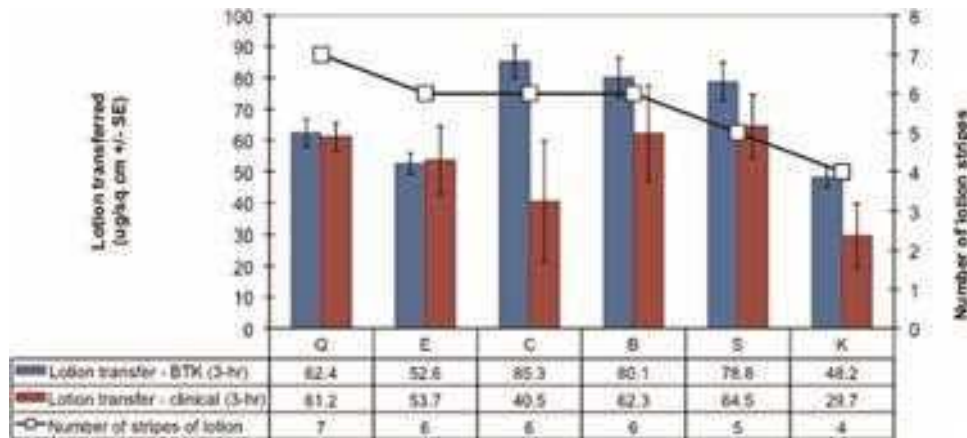
When the two test methods were compared, the BTK seemed to yield more consistent results when used as a means of determining the amount of lotion that transfers from feminine protection pads. As shown in Table 6.2, the lotion transfer from the second product application (six-hour time point) was approximately double the transfer from the first application

(Table 6.2). This would be expected since the six hours of application used two fresh pads. In the clinical in-use protocol, the amount of lotion transferred was inconsistent (Table 6.3).

The study measures only one parameter: transfer to an impermeable tape on the surface of the skin. It does not measure parts of the process that may reduce the apparent concentration of lotion on the surface, such as absorption of the lotion into the skin, or any transport or metabolism of lotion components from the epidermis or dermis. Obviously, some external factor, such as sweating, must have had an effect on the amount of lotion either transferred to the tape, or the amount remaining on the tape at the three-hour time point in the clinical study. Supporting this notion is the observation that with some individual panelists, the amount of lotion



**Figure 6.4** Lotion transfer as a function of pad thickness. Lotion transfer (in  $\mu\text{g}/\text{cm}^2$ ) from the second series of products, as measured in the BTK and clinical in-use studies after three hours of collection, is shown as a function of the thickness of the test pads (in mm). *Abbreviations:* AGM, absorbent gel materials; BTK, behind-the-knee; SE, standard error.



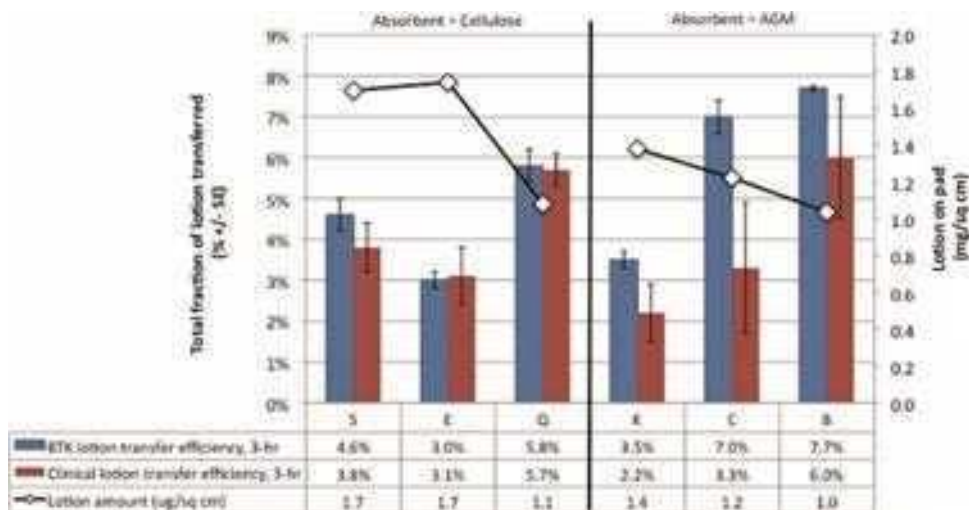
**Figure 6.5** Lotion transfer as a function of lotion configuration. Lotion transfer (in  $\mu\text{g}/\text{cm}^2$ ) from the second series of products, as measured in the BTK and clinical in-use studies after three hours of collection, is shown as a function of the lotion configuration on the pad, that is, the number of stripes of lotion. *Abbreviations:* BTK, behind-the-knee; SE, standard error.

transferred after 24 hours was actually less than that transferred after 3 hours (data not shown).

Of course, vulvar skin differs from the stratified squamous epithelium that would be found behind the knee (14). However, in this study, lotion transfer is to a tape applied to the surface of the skin, not to the skin itself. Therefore, physiological and/or biochemical differences between the skin of the vulva and the popliteal fossa cannot account for the different results observed with the two test methods. In both experiments, transfer of the lotion would depend only on the characteristics of the product itself, that is, the lotion formulation, the amount and configuration of the lotion, the topsheet, the thickness of the pad and the absorbent core. Therefore, the

extent of transfer should be additive for each product. In the clinical protocol, the amount of lotion transferred was not additive. Panelists used a total of 6.4 to 6.8 pads (sample applications) in each of the six test groups, but the increase in lotion transferred was 3.4 to 4.6 fold (Table 6.3).

As summarized in Table 6.4, the results of the BTK produced the same rank order of test products in terms of lotion transferred at the three- and six-hour time points. In most cases, the differences were significant. In contrast, the clinical in-use protocol produced a different rank order in the transfer amount, depending on the order of testing (i.e., phase 1 vs. phase 2), indicating the washout period was not effective. The 24-hour time point produced yet another rank order.



**Figure 6.6** Efficiency of lotion transfer for the two test protocols. The total fraction of the lotion transfer after three hours for both the BTK and clinical protocols was determined by dividing the amount transferred by the initial amount of lotion available per unit area. *Abbreviations:* AGM, absorbent gel materials; BTK, behind-the-knee; SE, standard error.

**Table 6.2** Results of Lotion Transfer Analysis Using the BTK Test Protocol

Product code	Absorbent	3 hr of application ( $\mu\text{g}/\text{cm}^2$ ) Mean $\pm$ SE	6 hr of application ( $\mu\text{g}/\text{cm}^2$ ) Mean $\pm$ SE	Total sample applications	Fold increase (6 vs. 3 hr)
C	AGM	85.3 $\pm$ 5.2 <sup>a</sup>	185.8 $\pm$ 8.0 <sup>b</sup>	2	2.2
B	AGM	80.1 $\pm$ 6.4 <sup>c</sup>	170.0 $\pm$ 7.6 <sup>d</sup>	2	2.1
S	Cellulose	78.8 $\pm$ 6.2 <sup>e</sup>	149.9 $\pm$ 11.6 <sup>f</sup>	2	1.9
Q	Cellulose	62.4 $\pm$ 4.4 <sup>g</sup>	111.5 $\pm$ 7.3	2	1.8
E	Cellulose	52.6 $\pm$ 3.4	105.8 $\pm$ 5.6	2	2.0
K	AGM	48.2 $\pm$ 3.3	105.6 $\pm$ 5.2	2	2.2

*Note:* The BTK protocol was conducted as described in the materials and methods. Three panels with 18 subjects each were used to compare lotion transfer from pairs of products (E vs. K, B vs. C, and Q vs. S). Two sections of tape were applied on the popliteal fossa of each leg, with test pads were placed horizontally and held in place by an elastic knee band. After three hours, one piece of tape was removed from each test site for analysis and fresh test product was applied for three more hours (i.e., a total of six hours of application). Results are given as  $\mu\text{g}$  lotion per unit area of tape ( $\mu\text{g}/\text{cm}^2$ ).

<sup>a</sup>C is significantly different from Q ( $p = 0.0016$ ), E ( $p < 0.0001$ ), and K ( $p < 0.0001$ ).

<sup>b</sup>C is significantly different from S ( $p = 0.0019$ ), and from Q, E, and K ( $p < 0.0001$  for all three).

<sup>c</sup>B is significantly different from Q ( $p = 0.0134$ ), E ( $p = 0.0002$ ), and K ( $p < 0.0001$ ).

<sup>d</sup>B is significantly different from Q, E, and K ( $p < 0.0001$  for all three).

<sup>e</sup>S is significantly different from Q ( $p = 0.0184$ ), E ( $p = 0.0003$ ), and K ( $p < 0.0001$ ).

<sup>f</sup>S is significantly different from Q ( $p = 0.0007$ ), E ( $p = 0.0002$ ), and K ( $p = 0.0002$ ).

<sup>g</sup>Q is significantly different from K ( $p = 0.0467$ ).

*Abbreviations:* AGM, absorbent gel materials; BTK, behind-the-knee; SE, standard error.

The clinical protocol is subject to a number of variables that do not impact the BTK protocol (reviewed in Table 6.5). First, as already mentioned, the number of pads used differs for different panelists, although this did not seem to account for any trends in the data. Differences in daily activities may also influence transfer amounts. In addition, even though the panelists all wear the identical type of panties issued by the test facility, the amount of pressure on the test site would vary depending on the fit of the panties (tight or loose) and the clothing preferences of the

panelists (i.e., pantyhose, tight jeans, or skirts). Further, the pressure would change throughout the 24-hour period as the panelist changes from regular clothing to looser-fitting sleepwear. The protocol used in the BTK would result in higher pressure on the test site, and the degree of pressure would be more consistent among different panelists, and for individual panelists throughout the course of the study. Finally, the clinical protocol design results in a high potential for removal of transferred lotion from the tapes during bathroom visits and other activities.

**Table 6.3** Results of Lotion Transfer Analysis Using the Clinical in-Use Test Protocol

Product code	Absorbent	3 hr of application, phase 1 ( $\mu\text{g}/\text{cm}^2$ )	3 hr of application, phase 2 ( $\mu\text{g}/\text{cm}^2$ )	24 hr of application, phases 1 and 2 ( $\mu\text{g}/\text{cm}^2$ )	Total sample applications <sup>a</sup>	Fold increase (24 vs. 3 hr)
		Mean $\pm$ SE	Mean $\pm$ SE	Mean $\pm$ SE		
S	Cellulose	64.5 $\pm$ 10.3	111.3 $\pm$ 11.6 <sup>b</sup>	279.7 $\pm$ 26.9	6.6	4.4
C	AGM	40.5 $\pm$ 19.3	90.7 $\pm$ 20.3 <sup>c</sup>	260.5 $\pm$ 53.0	6.5	4.2
Q	Cellulose	61.2 $\pm$ 4.5	53.3 $\pm$ 3.4	246.8 $\pm$ 22.1	6.4	4.0
E	Cellulose	53.7 $\pm$ 10.8	62.0 $\pm$ 12.6	235.0 $\pm$ 29.3	6.4	4.0
B	AGM	62.3 $\pm$ 15.2	56.0 $\pm$ 10.2	204.9 $\pm$ 38.2	6.8	3.4
K	AGM	29.7 $\pm$ 10.1	59.2 $\pm$ 10.4	202.8 $\pm$ 33.2	6.4	4.6

Note: The clinical in-use protocol was conducted as described in the materials and methods. Each product was tested on 12 subjects in a crossover design. Four sections of tape were applied to each side of the labia majora, and test pads were worn for three hours. After three hours two of the four tape sections were removed for determination of lotion transfer. The subjects applied the same test product for the remainder of the total 24-hour test period (approximately 21 hours). Subjects returned to the test facility, and the two remaining sections of tape were removed for analysis, thus completing test phase 1. After a “washout” period of 24 hours, the subjects repeated the test with a different product (phase 2). Results are given as  $\mu\text{g}$  lotion per unit area of tape ( $\mu\text{g}/\text{cm}^2$ ).

<sup>a</sup>Total sample application includes one for the 3-hour time point, plus the mean number of pads used in the 3- to 24-hour period, on the basis of subjects' logs.

<sup>b</sup>S is significantly different from E ( $p = 0.0070$ ), K ( $p = 0.0045$ ), B ( $p = 0.0041$ ), and Q ( $p = 0.0017$ ). S for phase 2 is significantly different from S from phase 1 (0.0103).

<sup>c</sup>C is significantly different from Q ( $p = 0.0387$ ). C for phase 2 is significantly different from C from phase 1 (0.0062).

Abbreviations: AGM, absorbent gel materials; SE, standard error.

**Table 6.4** Rank Order of Lotion Transfer Resulting from Evaluation by the BTK and Clinical Protocols

BTK protocol	
3 hr	C $\geq$ B $\geq$ S $>$ Q $>$ E $\geq$ K
6 hr	C $\geq$ B $>$ S $>$ Q $\geq$ E $\geq$ K
Clinical protocol	
3 hr (phase 1)	S $\geq$ B $\geq$ Q $\geq$ E $\geq$ C $\geq$ K
3 hr (phase 2)	S $\geq$ C $\geq$ E $\geq$ K $\geq$ B $\geq$ Q
24 hr (phases 1 and 2)	S $\geq$ C $\geq$ Q $\geq$ E $\geq$ B $\geq$ K

Note: The data presented in Tables 6.2 and 6.3 are summarized as a rank order of the amount of lotion transferred (from highest to lowest).

$>$  indicates a significant difference.

$\geq$  indicates a directional difference that did not reach significance.

Abbreviation: BTK, behind-the-knee.

**Table 6.5** Characteristics of the Two Test Protocols

Behind-the-knee	Clinical
Two applications for 3 hr each.	Varying number of applications over the 24-hr test period.
Conducting different activities during the test would have minimal effects due to the method of product application.	The effects of different activities on lotion transfer are unknown.
Application pressure of the sample is similar for all panelists because of the use of elastic knee braces in application.	Application pressure of the sample will vary among panelists depending on the fit of panties and clothing choices.
Application pressure of the sample for each panelist is consistent throughout the duration of the test.	Application pressure of the sample for each panelist throughout the test as the panelists change clothing, particularly as the panelists dress in loose-fitting sleepwear.
There is no potential for accidental removal of the transferred lotion by the panelists.	There is potential for accidental removal of the transferred lotion during bathroom visits and other activities.

## CONCLUSIONS

Both the BTK and the clinical protocol provide a means of evaluating the transfer of lotion formulations from feminine protection pads. However, this adaptation of the BTK test method provides more consistent results at a fraction of the cost.

## REFERENCES

- Farage MA, Ebrahimpour A, Steimle B, et al. Evaluation of lotion formulations on irritation using the modified forearm controlled application test method. *Skin Res Technol* 2007; 13:268–279.
- Baldwin S, Odio MR, Haines SL, et al. Skin benefits from continuous topical administration of a zinc oxide/petrolatum

- formulation by a novel disposable diaper. *J Eur Acad Dermatol Venereol* 2001; 15(suppl 1):5–11.
3. Odio MR, O'Connor RJ, Sarbaugh S, et al. Continuous topical administration of a petrolatum formulation by a novel disposable diaper: I. Effect on skin surface microtopography. *Dermatology* 2000; 200:232–237.
  4. Odio MR, O'Connor RJ, Sarbaugh S, et al. Continuous topical administration of a petrolatum formulation by a novel disposable diaper: II. Effect on skin condition. *Dermatology* 2000; 200: 238–243.
  5. Odio M, Friedlander SF. Diaper dermatitis and advances in diaper technology. *Curr Opin Pediatr* 2000; 12(4):342–346.
  6. Vieira L, Avila E, Warren R, et al. Lotion technology applied to pads: a different way of thinking about pads and women vulva skin (abstr). *Int J Gynecol Obstet* 2003; 83(suppl 3):85.
  7. Farage MA, Berardesca E, Maibach H. Skin Moisturization and frictional effects of an emollient-treated menstrual pad with a foam core. *Cutan Ocul Toxicol* 2009; 28(1):25–31.
  8. Farage MA. The behind-the-knee test: an efficient model for evaluating mechanical and chemical irritation. *Skin Res Technol* 2006; 12(2):73–82.
  9. Farage MA. Evaluating lotion transfer to skin from feminine protection products. *Skin Res Technol* 2008; 14:35–44.
  10. World Medical Association Declaration of Helsinki: ethical principles for medical research involving human subjects. *JAMA* 2000; 284(23):3043–3045.
  11. Farage MA. A behind-the-scenes look at the safety assessment of feminine hygiene pads. In: Creatsas G, Mastorakos G, Chrousos G, eds. *The Annals of New York Academy of Sciences*. Volume 1092. Women's health and disease: gynecologic, endocrine, and reproductive issues. 2006:66–77.
  12. Farage MA, Stadler A, Elsner P, et al. Safety evaluation of modern hygiene pads: two decades of use. *Female Patient* 2004; 29:23–30.
  13. Farage MA, Stadler A, Elsner P, et al. New surface covering for feminine hygiene pads: dermatological testing. *Cutan Ocul Toxicol* 2005; 24:137–146.
  14. Farage MA, Maibach HI. The vulvar epithelium differs from the skin: implications for cutaneous testing to address topical vulvar exposures. *Contact Dermatitis* 2004; 51:201–209.

## Nail penetration

Xiaoying Hui, Ronald C. Wester, and Howard I. Maibach

### INTRODUCTION

The human nail, equivalent to claws and hooves in other mammals, acts as a protective covering for the delicate tips of the fingers and toes against trauma, enhances the sensation of fine touch, and enables one to retrieve and manipulate objects. The nail is also used for scratching and grooming, as a cosmetic organ, and, by some, to communicate social status. The appearance of the nail plate is a thin, hard, yet slightly elastic, translucent, convex structure (1).

Disorders of the nail resulting from conditions such as infections or physical-chemical damage can result in painful and debilitating states, and often change the nail plate's appearance. Onychomycosis, the most common nail plate disorder (2), thickens the nail, makes it white and opaque, and may cause pain while wearing shoes. Onychomycosis is a fungal infection of the nail plate—usually caused by the species *Epidermophyton*, *Microsporium* and *Trichophyton*—and affects 14% of the human population. Aging increases the incidence significantly, with the rate estimated at 48% in persons 70 years of age (3).

To cure the infection, the patient is obliged to take oral systemic medication for an extended period, generally months, or undergo surgical nail removal (4). These treatments have adverse effects such as pain (surgery) and systemic side effects (oral treatment). Thus, topical therapy is a desirable approach, but has met with limited success. Topical therapy is limited by the infection's deep-seated nature and by the ineffective penetration of the deep nail plate by topically applied drugs (5,6).

How can topical drugs be delivered effectively into the nail? And, perhaps as importantly, how can the drug content in the human nail be assessed to validate nail drug delivery? Our challenge was to develop a system to assay drug content in the inner nail bed in which infection often resides. We developed a micrometer-controlled drilling instrument that removes and collects from the inner nail bed, a powder sample from which—by mass balance recovery—we assay the amount of penetrated radiolabeled drug. With this procedure, the effectiveness of topical nail drug delivery can be assessed (7,8). This paper reviews the results of studies undertaken with drilling system.

### REVIEW OF NAIL PHYSICAL AND CHEMICAL PROPERTIES THAT AFFECT TOPICAL PENETRATION

The human nail anatomy consists of nail plate, nail bed, and nail matrix. The nail plate consists of three layers: the dorsal and intermediate layers derived from the matrix, and the ventral layer from the nail bed (9,10). The upper (dorsal) layer is only a few cell layers thick and consists of hard keratin. It constitutes a main barrier to drug diffusion into and through the nail plate. The intermediate layer constitutes three quarters

of the whole nail thickness and consists of soft keratin. Below the intermediate layer is the ventral layer of soft keratin—a few cells thick—that connects to the underlying nail bed, in which many pathological changes occur. Thus, in the treatment of nail diseases, achieving an effective drug concentration in the ventral nail plate is of great importance. The nail bed consists of noncornified soft tissue under the nail plate. It is highly vascularized. Beneath the nail bed is the nail matrix, which is a heavily vascularized thick layer of highly proliferative epithelial tissue that forms the nail plate.

The human nail is approximately 100 times thicker than the stratum corneum, and both are rich in keratin. However, they exhibit some physical and chemical differences (11,12). The nail possesses high sulphur content (cystine) in its hard keratin domain, whereas the stratum corneum does not. The total lipid content of the nail ranges from 0.1% to 1%, as opposed to approximately 10% for the stratum corneum. This suggests that the role of the lipid pathway in the nail plate is probably of much less importance than that in the stratum corneum. The human nail acts like a hydrophilic gel membrane, while the stratum corneum acts like a lipophilic partition membrane.

Under average conditions, the nail contains 7% to 12% water, in comparison to 25% in the stratum corneum. At 100% relative humidity, the maximal water content in the nail approximate 25%, in sharp contrast to the stratum corneum that can increase its water content to 200% to 300%. The rate of chemical penetration into/through the human nail depends on its water solubility (11) and its molecular size (12).

Topical therapy for onychomycosis has been largely ineffective, and this failure may be due to minimal drug penetration into the nail plate (5). The nail's unique properties, particularly its thickness and relatively compact construction, make it a formidable barrier to the entry of topically applied agents (6). The concentration of an applied drug across the nail dropped about 1000-fold from the outer to the inner surface (13). As a result, the drug concentration presumably had not reached a therapeutically effective level in the inner ventral layer. The existing clinical evidence suggests that a key to successful treatment of onychomycosis by a topical antifungal product lies in effectively overcoming the nail barrier. Currently available topical treatments have limited effectiveness, possibly because they cannot sufficiently penetrate the nail plate to transport a therapeutically sufficient quantity of antifungal drug to the target sites (14) and eradicate the infection.

To achieve an effective chemical concentration into/through the human nail plate, penetration enhancers that tend to promote diffusion through the skin's horny layer have been studied. However, these studies were conducted on a few limited nail penetration models that may not provide an intimate

contact between the receptor compartment and the nail surface, and the nail plate can be easily hydrated beyond normal levels (6,11,12,14,15). Moreover, nail samples prepared with scalpel or sand paper are time consuming and may not be accurate to represent the three-nail compartment structure (10,16).

## METHODOLOGY

### Chemicals/Formulations

[<sup>14</sup>C]-Urea (specific activity 55 mCi/mmol, 99% purity), [<sup>7-<sup>14</sup>C</sup>]-salicylic acid (specific activity 55 mCi/mmol, 99% purity), and [<sup>3</sup>H(G)]-ketoconazole (specific activity 5 Ci/mmol, 99% purity) were purchased from American Radiolabeled Chemicals, Inc. (ARC, St. Louis, Missouri, U.S.). [<sup>14</sup>C]-AN2690 was synthesized by Amersham Biosciences UK Ltd. (Buckinghamshire, U.K.). [<sup>14</sup>C]-Econazole [chlorophenyl benzyl-<sup>14</sup>C]-(*D,L*)-econazole (chemical name: 1-[2-[(4-chlorophenyl)-methoxy]-2-(2,4-dichlorophenyl)ethyl]-1H-imidazole), [<sup>14</sup>C]-ciclopirox (pyridinone-6-(<sup>14</sup>C)-ciclopirox) was obtained from Perkin-Elmer Life Sciences, Inc. (Boston, Massachusetts, U.S.). [<sup>14</sup>C]-Terbinafine free base and [<sup>14</sup>C]-terbinafine hydrogen malate were obtained from Novartis Pharma AG (Basel, Switzerland). The radiochemical purities and specific activities of all chemicals were >98% and >98%, respectively. Penlac<sup>®</sup> nail lacquer (ciclopirox 8% topical solution) was manufactured by Dermik (Berwyn, Pennsylvania, U.S.). 2-*n*-Nonyl-1,3-dioxolane (SEPA), a penetration enhancer, and all necessary lacquer components were provided by MacroChem Corp. (Lexington, Massachusetts, U.S.).

### Formulations

Nails have a high content of disulfide bonds (10.6% vs. 1.2% for human skin), which make the nails both strong and impenetrable. To deliver a therapeutically sufficient quantity of an antifungal drug to fungally infected sites, such as nail plate, bed, and matrix, a suitable carrier is needed to enhance drug penetration through the nail barrier. In the case of urea, ketoconazole and salicylic acid, a lotion (Pennsaid lotion, Dimethaid Research Inc., Markham, Ontario, Canada) containing the penetration enhancer dimethyl sulfoxide (DMSO) had previously been shown to enhance skin penetration (7,8,17). To test these three drugs, we prepared three formulations with [<sup>14</sup>C]-urea, [<sup>3</sup>H]-ketoconazole, and [<sup>14</sup>C]-salicylic acid at 0.002%, 0.1%, and 0.07%, respectively and corresponding saline controls with each drug at the same concentrations (7).

For the antifungal drugs econazole, terbinafine free base, and terbinafine salt, we used a nail lacquer formulation, which is a popular choice for topical antifungal treatment. Nail lacquer contains a film-forming agent and a solvent, in addition to the antifungal drug and, possibly, a penetration enhancer. Once the lacquer is applied, it forms a thin, water-insoluble film containing the supersaturated antifungal drug. This provides a chemical gradient to drive drug flux as the drug is released. Thus, a lacquer formulation is suitable for topical treatment of nail diseases. We selected a commercial lacquer formulation, EcoNail (EcoNail is a trademark of MacroChem Corp.). The components of this lacquer formulation include econazole with penetration enhancer, 2-*n*-nonyl-1,3-dioxolane (18%), and were assembled into a test formulation in the lab prior to use (8). The control is the same formulation minus 2-*n*-nonyl-1,3-dioxolane.

[<sup>14</sup>C]-Ketoconazole was mixed with a filming solution, Time Off Nail (Neutrogena Corporation, Los Angeles, California, U.S.) to be a final 2% nail lacquer formulation. 2%

[<sup>14</sup>C]-Ketoconazole commercial cream was purchased from TEVA Pharmaceuticals USA (Sellersville, Pennsylvania, U.S.) and used for control.

AN2690 (5-fluoro-1,3-dihydro-1-hydroxy-2,1-benzoxaborole) was obtained from Anacor Pharmaceuticals, Inc. (Palo Alto, California, U.S.). Trace amount of [<sup>14</sup>C]-AN2690 was mixed with propylene glycol/ethanol (1:4, v/v) to a final 10% (w/v) test formulation (18). Penlac nail lacquer (ciclopirox 8% topical solution) was manufactured by Dermik (Berwyn) (19). Trace amount of [<sup>14</sup>C]-ciclopirox was mixed with the lacquer to be a control.

### Human Finger Nail Plates

Nail plates were collected from adult human cadavers and stored in a closed container at 0°C. Before each experiment, nail samples were gently washed with normal saline to remove any contamination, then rehydrated by placing them for three hours on a cloth wetted with normal saline. Nail samples were randomly selected and allocated to test groups. Nail thickness was measured by a Sony microdigital meter (Sony Magnescale Inc., Japan) before testing to determine the drilling depth for each nail. Five nails were used for each formulation tested.

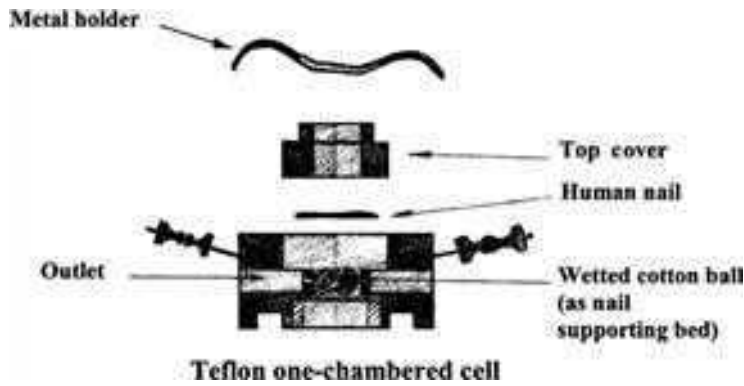
### Dosing and Surface Washing Procedures

A 10 µL dosing aliquot of each of the test formulations was applied to the surface of a nail plate with a microsyringe. Topical application was usually conducted in the morning. For twice daily dosing, a second one was done in the evening, 8 hours after morning application. Surface washing to remove the residue dose was done in the morning, 24 hours after the previous morning application, and 10 minutes prior to the next one if necessary. The nail was washed with cotton tips in a cycle as follows to simulate daily bathing: a dry tip, then a tip wetted with 50% Ivory liquid soap (Ivory is a registered trademark of Procter & Gamble, Cincinnati, Ohio, U.S.), then a tip wetted with distilled water, then another tip wetted with distilled water, then a final dry tip. The nails treated with lacquer also received an alcohol wash to remove residual lacquer that was insoluble in soap and water. The samples from each cycle from each nail were pooled and collected by breaking off the cotton tip into scintillation glass vials. An aliquot of 5.0 mL methanol was added to each vial to extract the test material. The radioactivity of each sample was measured in a liquid scintillation counter.

### Nail Incubation

To keep the nail at physiological levels of temperature and humidity, we incubated it in a Teflon one-chamber diffusion cell (PermeGear, Inc., Hellertown, Pennsylvania, U.S.). The nail surface (top center) was open to air and the inner surface made contact with a small cotton ball acting as a nail supporting bed (Fig. 7.1).

The cotton ball was wetted by normal saline. The incubation period started 24 hours prior to the first dose and ended 24 hours after the final dose. A small cotton ball wetted with 0.1 mL normal saline was placed in the chamber beneath the nail plate to serve as a "nail bed" and provide moisture for the nail plate, and hydration was monitored and controlled during the experiment (7,8). This cotton ball method prevented the over-hydration of a liquid interface. Cotton is a hydrophilic fiber that can contain high degree of moisture content, and absorbs



**Figure 7.1** Nail support and incubation system. The cotton ball prevented the overhydration of a liquid interface. Cotton is a hydrophilic fiber that can contain high degree of moisture content, and absorbs water-soluble substances. It also absorbs lipophilic substances, which can fill the lumen and lie between the numerous internal layers of the cotton (20). Thus, the cotton ball is an idea-receiving medium for in vitro transungual delivery. *Source:* From Ref. 7.

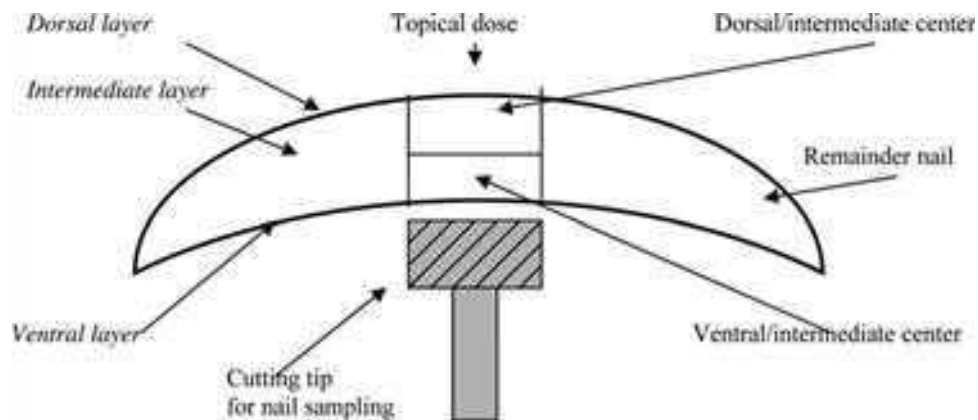
water-soluble substances. It also absorbs lipophilic substances, which can fill the lumen and lie between the numerous internal layers of the cotton (20). Thus, the cotton ball is an idea-receiving medium for in vitro transungual delivery.

**Nail Sampling**

The objective was to determine drug concentration within the nail where the disease resides. Treatment is applied to the nail surface. The drilling system samples the inner core of the nail without disturbing the nail surface. The two parts (surface and inner core) can be assayed separately. The surface contains only residual drug after washing. The drilled out core (from the ventral side) is thus a true drug measurement at the target site where the disease resides (Fig. 7.2). Drug penetration into the nail was sampled by a unique micrometer-controlled nail-sampling instrument that enabled finely controlled drilling into the nail and collection of the powder created by the drilling process (7,8). The nail-sampling instrument (Fig. 7.3) has two parts, a nail sample stage and a drill. The nail-sampling stage consists of a copper nail holder, three adjustments, and a nail powder capture. The three adjustments control vertical movement. The first coarse adjustment (on the top) is for changing the copper cell and taking powder samples from the capture.

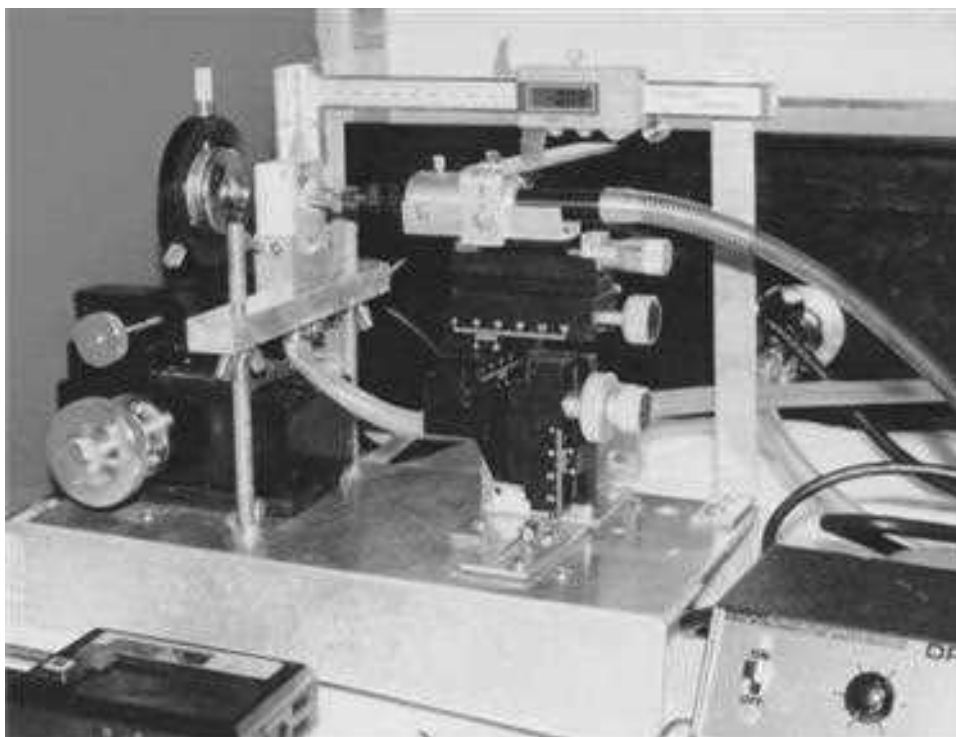
The other two adjustments (lower) are used in sampling. The second coarse adjustment allows movement of 25 mm, while the fine adjustment provides movement of 0.20 mm. The nail powder capture is located between the copper cell and the cutter. The inner shape of the capture is an inverted funnel with the end connected to a vacuum pump. By placing a filter paper inside the funnel, nail powder samples can be captured on the filter paper during sampling. The nail is fastened in a cutting holder below the cutter and surrounded by a funnel containing a filter paper. The funnel is attached to a vacuum pump. During drilling, the vacuum draws the powder debris onto the filter paper so that it can be collected and measured and increase total collection for mass balance determination.

After completion of the dosing and incubation phase, the nail plate was transferred from the diffusion cell to a clean cutting holder for sampling. The nail plate was secured in position so that the ventral surface faced the cutter and the dorsal-dosed surface faced the holder. The cutting holder was moved to bring the plate surface just barely in contact with the cutter tip. The drill was then turned on and a fine adjustment moved the stage toward the cutter tip, removing a powder sample from the nail. In this way, a hole approximately 0.3 to 0.4 mm in depth and 7.9 mm in diameter was drilled in each nail, enabling the harvest of powder sample from the center of



**Figure 7.2** Nail and nail drilling tip.





**Figure 7.3** The nail-sampling system. The instrument has two parts, a stage and a drill. The stage consists of a copper nail holder, three adjustments, and a nail powder capture. During drilling, the vacuum draws the powder debris onto the filter paper so that it can be collected and measured and increase total collection for mass balance determination.

each nail's ventral surface. We refer to these samples as having been taken from the "ventral/intermediate nail plate."

After the nail had delivered its ventral/intermediate nail plate powder samples, it was removed from the sampling instrument. The nail outside the dosing area was cut away and discarded. The nail within the dosing area but outside the sampling area was trimmed away and saved; we refer to this as the "remainder nail plate." It surrounds the dorsal layer above the sampling area where the powder samples were taken; we refer to this as the "sampling area dorsal nail plate." The ventral/intermediate nail plate powdered samples, the sampling area dorsal nail plate, and the remainder nail plate were individually collected into a glass scintillation vial and weighed. The nail samples were then dissolved by adding

5.0 mL of a Packard Soluene-350 (Packard Instrument Company, Meriden, Connecticut, U.S.). The total mass of nail collected was measured by the difference in weight of the plate before and after drilling (7,8).

## RESULTS

### Nail Incubation Conditions

Table 7.1 shows that the average hydration of the wetted cotton balls  $109 \pm 6.2$  AU that resembles the average hydration of human nail bed,  $99.9 \pm 8.9$  AU measured from fresh human cadavers, where AU is Arbitrary Units, a digital expression of capacitance. During the experiment, the holding tank temperature was  $25 \pm 2^\circ\text{C}$  and relative humidity was

**Table 7.1** Hydration of Nail Plate and Nail Bed<sup>a</sup>

Source	Measurement <sup>b</sup>		Hydration (AU) <sup>c</sup>	
	N	Time	Nail plate	Nail bed
Human cadavers	6	24-hr postmortem	$7.6 \pm 0.9$	$99.9 \pm 8.9$
Diffusion cells	8	Twice/day for 7 days	$8.5 \pm 2.4$	$109.9 \pm 6.2$

<sup>a</sup>During the experiment, the holding tank temperature was  $25 \pm 2^\circ\text{C}$  and relative humidity was  $44 \pm 8\%$ . The importance of this controlled temperature and humidity is to mimic normal physiological condition of the human nail to prevent overhydration that was easily occurred in nail in vitro studies.

<sup>b</sup>Hydration of the nail plate and the supporting cotton bed was measured with a Corneometer CM 820 (Courage + Khazaka, Cologne, Germany).

<sup>c</sup>AU is Arbitrary Units, a digital expression of capacitance. Thus, the CM820 Corneometer gives only an estimate of the nail (or other membrane such as stratum corneum) hydration. Agache et al. (21) used a sorption-desorption test to assess the water content of the stratum corneum. They correlated the results measured with the CM820 Corneometer (as AU unit) and TEWL ( $\text{g}/\text{m}^2 \cdot \text{hr}$ ) measured with an evaporimeter and found that water retained in the SC ( $\mu\text{g}/\text{cm}^2$ ) =  $\ln(\text{AC}/3.8)/0.0436$ . From Ref. 21.

**Table 7.2** Nail Core Sampled from the Ventral (Inner) Surface Center of the Human Nail Plate

Test number	Whole nail thickness (mm)	Nail core sampled from the ventral (inner) surface center of the nail plate <sup>a</sup>			
		Depth of core (mm)	% Whole nail thickness	Total core sample removed (mg)	Powder sample collected (mg)
Urea (control)	0.65 (0.09)	0.25 (0.03)	39.52 (8.05)	16.4 (4.3)	5.2 (0.8)
Urea (test)	0.71 (0.07)	0.27 (0.03)	37.97 (2.69)	17.6 (4.3)	6.4 (1.3)
Ketoconazole (control)	0.68 (0.05)	0.28 (0.03)	41.88 (1.16)	14.3 (6.7)	6.7 (2.6)
Ketoconazole (test)	0.73 (0.03)	0.28 (0.02)	38.62 (2.69)	14.1 (5.1)	4.3 (1.6)
Salicylic acid (control)	0.77 (0.07)	0.25 (0.08)	32.62 (9.38)	12.1 (2.4)	6.0 (0.5)
Salicylic acid (test)	0.60 (0.12)	0.21 (0.06)	35.03 (6.45)	23.4 (8.3)	4.7 (0.8)
Average	0.69 (0.09)	0.26 (0.05)	37.61 (6.20)	16.3 (6.2)	5.5 (1.6)

<sup>a</sup>Nail sample, approximately 0.24 mm in depth and 7.9 mm in diameter, was drilled from the center of the ventral surface of the nail. The amount of nail sample removed was measured by difference in weight and depth of the drilled area before and after sampling. Each number represents mean (±SD) of five samples.

The data demonstrated the repeatability and accuracy of the nail-sampling system.

Source: From Ref. 7.

44 ± 8%. Thus, there was no statistical difference between hydration conditions for nails treated with either the test formulation or the saline control. This incubation device is nonocclusive and hydration controlled, and approximate normal physical condition is reached.

**Accuracy of Nail-Sampling Process**

The advantage of the micrometer-controlled drilling and nail powder removal system is the accuracy of the sampling process. The sampling instrument allowed well-controlled, accurate, and reproducible sampling of the inside of the nail. Table 7.2 shows that the average depth of nail sampling from the inner center surface was well controlled at 0.26 ± 0.05 mm, which was close to the expected depth of 0.24 mm. The weight of the nail samples collected was consistent for all experiments.

**Mass Balance of Radioactivity Recovery**

Table 7.3 summarizes the econazole mass balance recovery following the 14-day nail treatment. Overall recovery of

applied dose was 90.8 ± 16.4% for the test formulation and 96.4 ± 7.3% for the saline control, indicating that essentially the entire dose was accounted for.

Table 7.3 also indicates what happens to chemicals applied to the nail. Approximately 72% was washed from the surface. The dose absorbed from the surface of the nail penetrated to the sampling area dorsal nail plate (11.4%), the ventral/intermediate nail plate (1.4%), and the supporting bed (0.7%), which is the cotton ball on which the nail rested. Note that econazole recovery in the test formulation is greater for both the ventral/intermediate nail plate and the supporting bed, which is an effect of the drug delivery enhancer. At the sampling area dorsal nail plate, there is more econazole from the saline control because the dose remained on the nail surface.

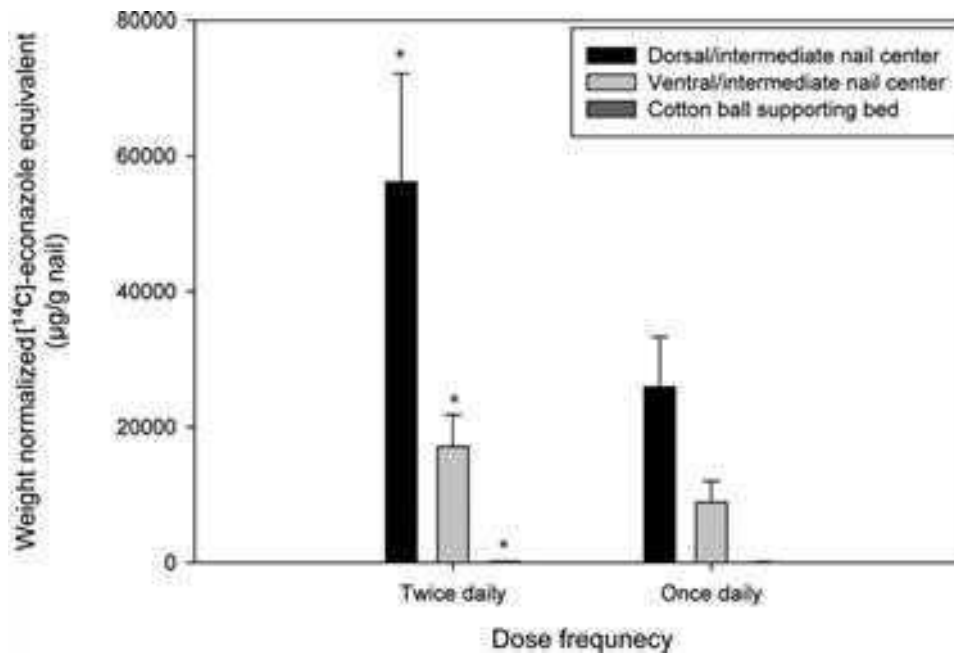
**Effects of Dosing and Washing Frequency**

Figures 7.4 and 7.5 show the weight of normalized [<sup>14</sup>C]-econazole equivalent in different layers of the nail plate and cumulative [<sup>14</sup>C]-econazole equivalent collected in the cotton ball-supporting bed following different frequency of topical

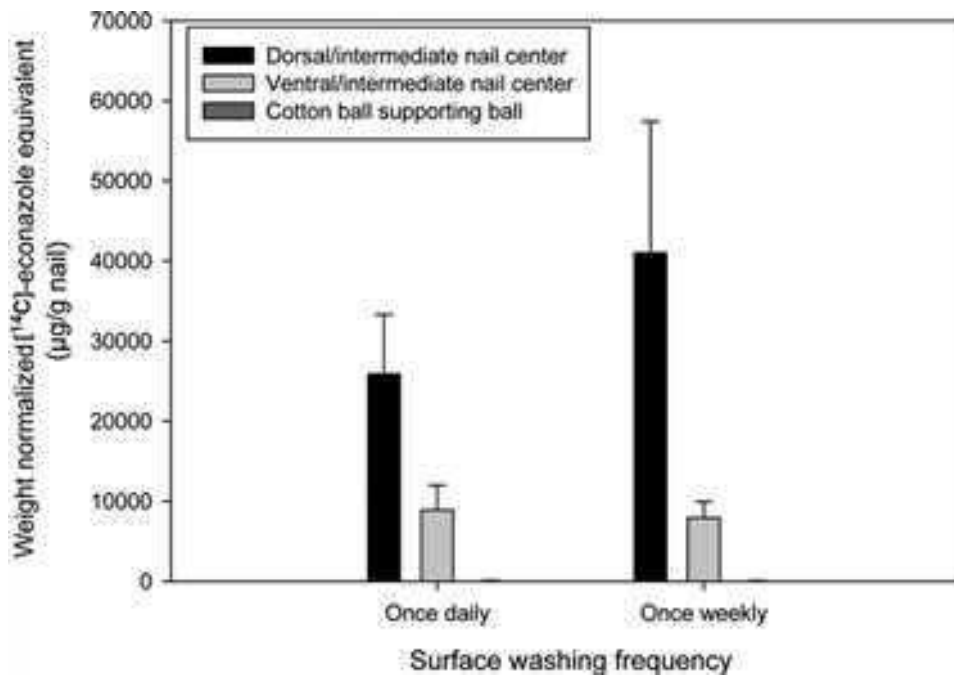
**Table 7.3** Mass Balance Recovery of Econazole Following 14-day Human Nail Treatment with a Test Formulation Containing a Penetration Enhancer and a Control Without a Penetration Enhancer<sup>a</sup>

Sampling area	Carbon-14 recovery as percent of dose	
	Test formulation	Control formulation
Dorsal/intermediate nail plate	11.4 (3.6)	20.1 (2.9)
Ventral/intermediate nail plate (powdered samples)	1.3 (1.1)	0.22 (2.9)
Remainder nail plate	5.6 (3.9)	3.2 (2.3)
Supporting bed (cotton ball)	0.7 (0.3)	0.0 (0.0)
Surface washes	71.7 (12.5)	72.8 (5.1)
Total	90.8 (16.4)	96.4 (7.3)

<sup>a</sup>From Ref. 8. The data represent the mean (SD) of each group (n = 5). The test formulation group contains 18% 2-n-nonyl-1,3-dioxolane and the control formulation contains no 2-n-nonyl-1,3-dioxolane. The data demonstrated not only the importance of the penetration enhancer but the high recovery rate of two groups when using the nail-sampling system.



**Figure 7.4** Nail penetration profile of [<sup>14</sup>C]-econazole following a 14-day treatment/incubation period in vitro. Each bar represents the mean (SD) of six samples. The frequency of topical dosing was different but the surface wash was the same, once daily. (\*) The group received twice daily topical doses was statistically significant higher than the one treated once daily dose ( $p < 0.05$ ).



**Figure 7.5** Nail penetration profile of [<sup>14</sup>C]-econazole following a 14-day treatment/incubation period in vitro. Each bar represents the mean (SD) of 6 samples/group. Each group was received once daily topical application for 14 days. The frequency of surface washing for each group was different. The group was received daily washing was no statistically significant than the corresponding bar from the once weekly washing one ( $p > 0.05$ ).

dosing or surface washing treatments. As expected after twice daily application (and surface washing once daily) for 14 days, the [<sup>14</sup>C]-econazole content in all nail and cotton ball samples were significantly higher than those in the dosing and washing once daily group ( $p < 0.05$ ), whereas comparison of the once daily dosing and washing treatment group and the once daily dosing and once weekly washing group did not show significant difference for all collected samples ( $p > 0.05$ ).

**Enhancer Effects**

Table 7.4 summarizes the penetration of ketoconazole, urea, and salicylic acid into the human inner nail plate. Each test formulation contained a drug delivery enhancer (7,8) and was compared to a control formulation without any penetration enhancer. In each case, the test formulation enhanced drug delivery ( $p < 0.05$ ). Table 7.5 comprises antifungal efficacy of econazole, terbinafine base, and terbinafine salt following

topical applications. Each test antifungal agent contains 18% 2-*n*-nonyl-1,3-dioxolane (SEPA), a skin penetration enhancer, and the control (no 18% 2-*n*-nonyl-1,3-dioxolane). All test formulations show the antifungal efficacy coefficient ( $E$ ) was significantly higher than that of corresponding control ( $p < 0.05$ ).

**Topical Formulation Comparison**

Table 7.6 comprises [<sup>14</sup>C]-ciclopirox penetration into/through nail plate in vitro from three topical formulations, market gel, experimental gel, and lacquer. The order of deeper penetration, amount detected in the ventral/intermediate nail center, and cotton ball supporting bed samples was from the highest to the lowest, market gel, lacquer, and experimental gel, respectively. Figure 7.6, however shows that the deeper penetration of a lacquer formulation of ketoconazole was greater than that of cream when comparing their antifungal efficacy coefficient ( $p < 0.05$ ).

**Table 7.4** Radiolabeled Drug Penetration into Human Nail from a Test Formulation Containing DMSO, a Penetration Enhancer Vs. a Control Without a Penetration Enhancer

Test chemicals	Penetration enhancer <sup>a</sup>	Radioactivity content in ventral/intermediate center layer of the nail plate <sup>b</sup>			
		Unit <sup>c</sup>	Test formulation	Control formulation	Significant ( $p < 0.05$ )
Ketoconazole	DMSO	μg eq/g	53.9 (10.6)	34.0 (15.9)	Yes
Urea	DMSO	μg eq/g	0.3 (0.1)	0.2 (0.1)	Yes
Salicylic acid	DMSO	μg eq/g	10.2 (0.6)	7.0 (1.1)	Yes

<sup>a</sup>DMSO is a transdermal delivery enhancer. The enhancement mechanism of transungual delivery is not clear. However, it did enhance the nail penetration of the test chemicals.  
<sup>b</sup>From Ref. 7. The data represent the mean (SD) of five samples per formulation group. The nail sample drilled as powder from ventral/intermediate layer of human nail plate.  
<sup>c</sup>μg eq/g = microgram equivalents drug per gram of nail sample. Because radioactivity is used, the drug mass is referred to as “equivalents” because radioactivity was measured, not the drug itself.  
*Abbreviation:* DMSO, dimethyl sulfoxide.

**Table 7.5** Comparison of Econazole Concentration and Relative Antifungal Efficacy with a Test Formulation Containing 2-*n*-Nonyl-1, 3-Dioxolane, a Penetration Enhancer and a Control<sup>a</sup>

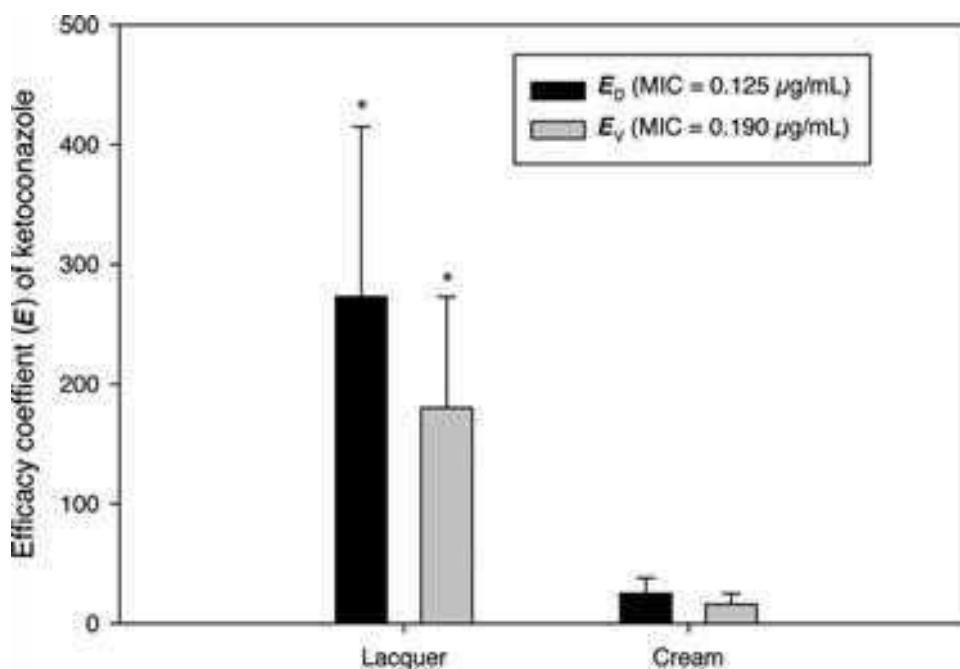
Parameter <sup>b</sup>	Test formulation	Control formulation	Significant ( $p < 0.05$ )
Econazole in the deeper layer (μg/cm <sup>3</sup> )	14,830 (341)	2,371 (426)	Yes
$E_D$ (MIC <sub>D</sub> = 1 μg/mL) <sup>c</sup>	14,830	2,371	Yes
$E_Y$ (MIC <sub>Y</sub> = 100 μg/mL) <sup>c</sup>	148	23.7	Yes
Terbinafine salt in the deeper layer (μg/cm <sup>3</sup> )	5946 (1029)	463 (271)	Yes
$E_D$ (MIC <sub>D</sub> = 0.04 μg/mL) <sup>d</sup>	5946	463	Yes
$E_Y$ (MIC <sub>Y</sub> = 1.77 μg/mL) <sup>d</sup>	134	10	Yes
Terbinafine base in the deeper layer (μg/cm <sup>3</sup> )	727 (372)	407 (106)	Yes
$E_D$ (MIC <sub>D</sub> = 0.04 μg/mL) <sup>d</sup>	1527	156	Yes
$E_Y$ (MIC <sub>Y</sub> = 1.77 μg/mL) <sup>d</sup>	34	3	Yes

<sup>a</sup>The data represent the mean (SD) of each group ( $n = 5$ ). The test formulation group contains 18% 2-*n*-nonyl-1,3-dioxolane and the control formulation contains no 2-*n*-nonyl-1,3-dioxolane.  
<sup>b</sup>The deeper layer is the center of the ventral/intermediate layer of the nail plate. The data represent the amount drug in the sample after a 14-day dosing period. The amount of antifungal agents in the tested nail layer (μg/cm<sup>3</sup>) was computed from the average of the cumulative amount of the test agent permeated into the area (area × thickness) of the deeper layer of the nail (dorsal/intermediate layer).  
<sup>c</sup>From Ref. 8.  $E$  is antifungal efficacy coefficient and MIC is the minimum inhibitory concentration of the tested antifungal agent. D is dermatophytes and Y is yeast.  
<sup>d</sup>From Ref. 22.  
*Abbreviation:* MIC, minimum inhibitory concentration.

**Table 7.6** Summary of Weight Normalized [ $^{14}\text{C}$ ]-ciclopirox Equivalent in the Nail and Supporting Bed Samples After 14-Day Treatment

Items (unit)	Normalized [ $^{14}\text{C}$ ]-ciclopirox equivalent <sup>a</sup>			Significant (if $p$ -value < 0.05)
	Marketed gel	Experimental gel	Lacquer	
Dorsal/intermediate center within surface of nail ( $\mu\text{g eq/mg}$ )	71.7 (16.8)	103.4 (38.1)	2162.1 (526.4)	Lacquer vs. experimental gel Lacquer vs. marketed gel
Ventral/intermediate center within infection-prone area ( $\mu\text{g eq/mg}$ )	0.6 (0.3)	0.2 (0.1)	0.3 (0.1)	Marketed gel vs. lacquer Marketed gel vs. experimental gel Experimental gel vs. lacquer
Penetration through the nail into the supporting bed cotton ball ( $\mu\text{g eq/sample}$ )	46.3 (4.1)	6.0 (1.3)	15.5 (3.1)	Marketed gel vs. lacquer Marketed gel vs. experimental gel Experimental gel vs. lacquer

<sup>a</sup>From Ref. 19. The data represents the mean (SD) of each group ( $n = 5$ ).



**Figure 7.6** Comparison of antifungal efficacy coefficient of two ketoconazole formulations, lacquer and cream. Each bar represents the mean (SD) of 5 samples/group. Each group received once daily topical dose and washing for a seven-day treatment. The lacquer group shows that the antifungal efficacy coefficient was statistically significant higher than that of the cream group ( $p < 0.05$ ).

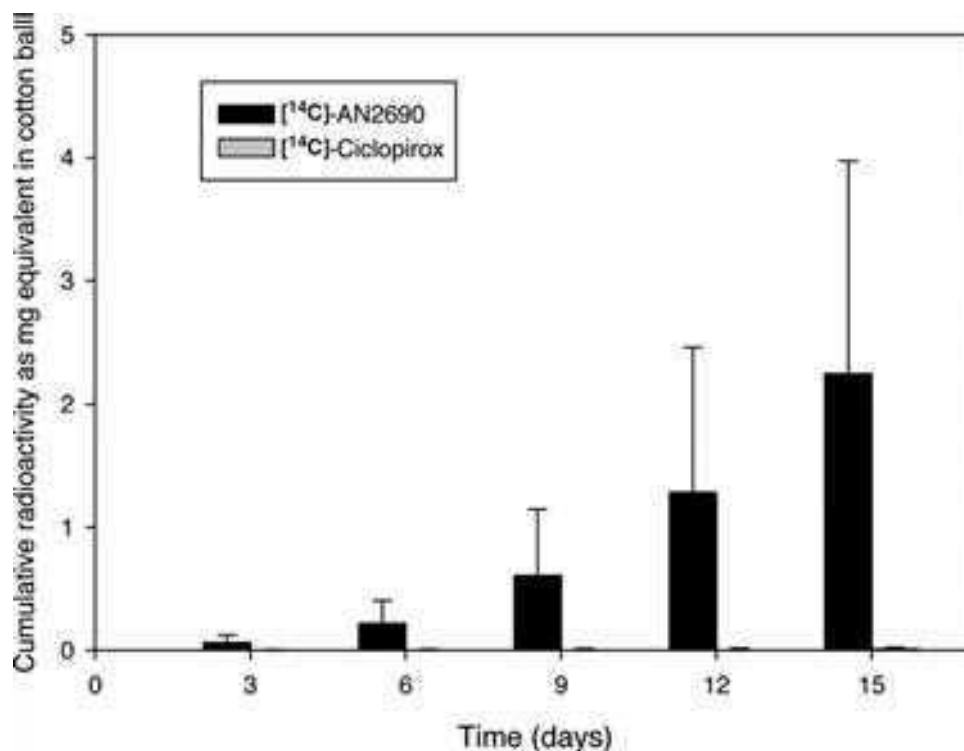
## DISCUSSION

Topical therapy for onychomycosis is not yet maximally effective, and this failure may be due to inadequate penetration of drugs into the nail plate. The nail's unique properties, particularly its thickness and relatively compact construction, make it a formidable barrier to the entry of topically applied agents. The concentration of an applied drug across the nail drops about 1000-fold from the outer surface to the inner surface. As a result, the drug concentration presumably does not reach a therapeutically effective level in the ventral/intermediate layers. To optimize the nail penetration of topical treatments, it is important to consider the nail's unique barrier properties and develop an antifungal drug formulation that has matching physicochemical properties.

Nail lacquer formulations, a popular choice for topical antifungal treatment, typically contain a film-forming agent,

solvent, antifungal drug, and possibly a penetration enhancer. Once the lacquer is applied, it forms a thin film containing a supersaturated antifungal drug. This film provides a chemical gradient to drive drug flux as the drug is released. For an example, [ $^{14}\text{C}$ ]-ketoconazole lacquer yields a significant number of antifungal efficacy coefficients than that in cream ( $p < 0.05$ , Fig. 7.6). However, the nail deeper penetrations of [ $^{14}\text{C}$ ]-ciclopirox from the commercial available formulation, Penlac nail lacquer (ciclopirox 8% topical solution), was statistically lower than that of market gel formulation (ciclopirox 0.77% topical solution) (Table 7.6) (19). When compared with other antifungal topical formulations, such as [ $^{14}\text{C}$ ]-AN2690, 10% (w/v) in propylene glycol/ethanol solution, it decreased ( $p < 0.05$ ) the deeper nail layer penetration rate (Fig. 7.7) (18).

Transungual enhancement has been examined: dimethyl sulfoxide (DMSO) and 2-*n*-nonyl-1,3-dioxolane used as



**Figure 7.7** Cumulative amounts of AN 2690 and ciclopirox (mg equivalent) in cotton ball supporting bed samples following a 14-day treatment. The test formulations were dosed daily, and the dose residue was washed 24 hours later and 10 minutes prior to the next application. Each bar represents the mean (SD) of 6 samples/group. Each bar of the AN2690 group was statistically higher than the corresponding one from the ciclopirox group ( $p < 0.05$ ). *Source:* From Ref. 18.

transdermal delivery enhancers were tested for enhancement of antifungal agents penetrating into and through the nail plate in vitro. The two enhancers increased the deeper nail penetration of [<sup>14</sup>C]-ketoconazole (Table 7.3), [<sup>14</sup>C]-econazole, [<sup>14</sup>C]-terbinafine salt, and [<sup>14</sup>C]-terbinafine base (Table 7.5) when significantly compared to the controls ( $p < 0.05$ ). DMSO has been previously reported to facilitate the penetration of some topical antimycotics (15,23). The enhancement function of 2-*n*-nonyl-1,3-dioxolane has not previously been determined. The mechanism of 2-*n*-nonyl-1,3-dioxolane in skin penetration was suggested to reversibly fluidize the stratum corneum lipids and alter barrier function (24). However, [<sup>14</sup>C]-dioxolane, the radio-labeled 2-*n*-nonyl-1,3-dioxolane, had minimal penetration to and through the human nail plate in vitro (8). Since 2-*n*-nonyl-1,3-dioxolane can function as an adhesion promoter and a plasticizer for the film-forming polymer of the nail lacquer (25,26). The enhancement function of 2-*n*-nonyl-1,3-dioxolane for the tested antifungal agents was possibly to soften the lacquer film to increase releasing per unit time (8). As shown in Table 7.5, the amounts of [<sup>14</sup>C]-econazole, [<sup>14</sup>C]-terbinafine free base, and [<sup>14</sup>C]-terbinafine salt detected from the deeper layer, ventral/intermediate nail layer in the test groups containing 18% 2-*n*-nonyl-1,3-dioxolane, were significantly greater than that of in the controls ( $p < 0.05$ ). The results suggest that the enhanced level of these antifungal agents in the ventral/intermediate layers and supporting bed dramatically increased, which exceeds the minimum inhibitory concentration

(MIC) of econazole for most common onychomycosis organisms (Table 7.5).

MIC is a laboratory index in the determination of antifungal potency. Martin and Lippold (11) introduced an efficacy coefficient  $E$  to better estimate and compare the relative efficacy of antifungal agents. The efficacy coefficient  $E$  is the ratio of the flux of an antimycotic drug through the nail plate to the MIC. For econazole, the range of MIC for dermatophytes species is 0.1 to 1.0  $\mu\text{g}/\text{mL}$  and for yeast species it is 1.0 to 100  $\mu\text{g}/\text{mL}$  (27). After 14 days of exposure, the econazole content measured in the test group was  $11.15 \pm 2.56 \mu\text{g}/\text{mg}$  for the ventral/intermediate layers. This content multiplied by the density of the nail sample ( $1.332 \text{ mg}/\text{cm}^3$ , measured under current experimental conditions) yields  $14,830 \pm 340 \mu\text{g}/\text{cm}^3$  of econazole, almost 15,000 times the MIC for most dermatophytes species and 150 times that for most yeast species (Table 7.5).

This study demonstrated that with our in vitro nail study methodology, the nail plate can be scientifically studied, and with proper formulation one can deliver a variety of chemicals, be they drugs or nail modifiers (cosmetics). The nail is now ready for serious attention and treatment just as hair and skin have been in the past. The nail barrier can be breached.

These findings presumably relate to delivery of cosmetic agents for the management of nail abnormalities, such as nails that are peeling or fragile. R&D on these agents will be simplified when the rules describing the relationship of

physical chemistry to flux are developed for the nail, as they have been in part for the skin.

Taken together, the methodology appears robust, as with other models, inclusion of other chemicals with varying physicochemical properties, and in vivo replication will add strength to the results.

## REFERENCES

- Murdan S. Drug delivery to the nail following topical application. *Int J Pharm* 2002; 236:1–26.
- Taylor EJ, ed. *Dorland's Illustrated Medical Dictionary*. 27th ed. Philadelphia: WB Saunders, 1988.
- Elewski B, Charif MA. Prevalence of onychomycosis in patients attending a dermatology clinic in northeastern Ohio for other conditions. *Arch Dermatol* 1997; 133:1172–1173.
- Nolting S, Korting HC, eds. *Onychomycoses—Local Antimycotic Treatment*. New York: Sapriner-Verlag, 1990.
- Meisel CW. The treatment of onychomycosis. In: Nolting S, Korting HC, eds. *Onychomycoses—Local Antimycotic Treatment*. New York: Sapriner-Verlag, 1990:12–28.
- Walters KA, Flynn GL. Permeability characteristics of the human nail plate. *Int J Cosmetic Sci* 1983; 5:231–246.
- Hui X, Shainhouse JZ, Tanojo H, et al. Enhanced human nail drug delivery: nail inner drug content assayed by new unique method. *J Pharm Sci* 2002; 91:189–195.
- Hui X, Barbadillo S, Lee C, et al. Enhanced econazole penetration into human nail by 2-N-nonyl-1,3-dioxane. *J Pharm Sci* 2003; 92:142–148.
- Runne U, Orfanos CE. The human nail—structure, growth and pathological changes. *Curr Probl Dermatol* 1981; 9:102–149.
- Kobayashi Y, Miyamoto M, Sugibayashi K, et al. Drug permeation through the three layers of the human nail plate. *J Pharm Pharmacol* 1999; 51:271–278.
- Martin D, Lippold BC. In vitro permeability of the human nail and a keratin membrane from bovine hooves: influence of the partition coefficient octanol/water and the water solubility of drugs on their permeability and maximum flux. *J Pharm Pharmacol* 1997; 49:30–34.
- Martin D, Lippold BC. In vitro permeability of the human nail and a keratin membrane from bovine hooves: prediction of the penetration rate of antimycotics through the nail plate and their efficacy. *J Pharm Pharmacol* 1997; 49:866–872.
- Stüttgen G, Bauer E. Bioavailability, skin- and nail penetration of topically applied antimycotics. *Mykosen* 1982; 25:74–80.
- Walters KA, Flynn GL, Marvel JR. Physicochemical characterization of the human nail: solvent effects on the permeation of homologous alcohols. *J Pharm Pharmacol* 1985; 37:771–775.
- Walters KA, Flynn GL, Marvel JR. Physicochemical characterization of the human nail: I. Pressure sealed apparatus for measuring nail plate permeabilities. *J Invest Dermatol* 1981; 76:76–79.
- Polak A. Kinetic of amorolfine in human nails. *Mycoses* 1993; 36:101–103.
- Hui X, Hewitt HG, Poblete N, et al. In vivo bioactivity and metabolism of topical diclofenac lotion in human volunteers. *Pharm Res* 1998; 15:1589–1595.
- Hui X, Baker SJ, Wester RC, et al. In vitro penetration of a novel oxaborole antifungal (AN 2690) into the human nail plate. *J Pharm Sci* 2007; 96:2622–2631.
- Hui X, Wester RC, Barbadillo S, et al. Ciclopirox delivery into the human nail plate. *J Pharm Sci* 2004; 93:2545–2548.
- Hatch KL, ed. *Textile Science*. St. Paul Minneapolis: West Publishing Co., 2006.
- Agache P, Mary S, Muret P, et al. Assessment of the water content of the stratum corneum using a sorption-desorption test. *Dermatology* 2001; 202:308–313.
- Gupta AK, Kohli Y. In vitro susceptibility testing of ciclopirox, terbinafine, ketoconazole and itraconazole against dermatophytes and nondermatophytes, and in vitro evaluation of combination antifungal activity. *Br J Dermatol* 2003; 149:296–305.
- Franz TJ. Absorption of amorolfine through human nail. *Dermatology* 1992; 184(suppl 1):18–20.
- Morganti F, Bramanti E, Solaro R, et al. Thermal and spectroscopic characterization of interactions between 2-n-nonyl-1,3-dioxolane and stratum corneum components. *J Bioactive Compatible Polym* 2000; 14:162.
- Samour CM, Krauser SF. Antifungal nail lacquer and method using same. U.S. Patent 6,224,887. May 1, 2001.
- Samour CM, Donaruma LG, Daskalakis S, et al. SEPAs, a new class of percutaneous absorption enhancers. *Proc Int Symp Control Release Bioact Mat* 1989; 16:183.
- Thienpont D, Cutsem JV, Nueten JMV, et al. Biological and toxicological properties of econazole, a broad-spectrum antimycotic. *Arzneimittelforschung* 1975; 25:224–231.

# Sensitive skin: new findings yield new insights

Miranda A. Farage and Howard I. Maibach

## INTRODUCTION

The goal of product testing is to ensure that consumer products are free of irritant potential and to prevent unexpected consumer reactions to the product once it reaches the marketplace. It is not uncommon, nonetheless, for postmarketing surveillance efforts to receive reports of sensory perceptions not predicted by even the most robust development methodology (1). These sensory perceptions, though often transient and not accompanied by a visual dermatological response, even under rigorous experimental testing, strongly influence consumer product preference (1). In fact, 78% of consumers who profess sensitive-skin report avoiding some products because of unpleasant sensory effects associated with their use (2).

These unpleasant and subjective sensory effects, often unaccompanied by objective physical signs, define a controversial and still evolving dermatological condition known as *sensitive skin*. Consumer reports of sensitive skin are typically self-diagnosed and may be increasing (3). It has been proposed in both the popular media (4) and the medical literature (5,6) that the increasing incidence of sensitivity represents a “princess and the pea” effect, wherein it has become culturally fashionable to claim sensitive skin. The majority of women in the United States, Europe, and Japan (which represents the vast majority of patients queried to this date), now believe they have sensitive skin (5), which tends to support a psychosocial component. The phenomenon is recorded in all industrial nations (2), however, and the finding of equivalent prevalence in two separate continents [68% (3) and 64% (7)] lends credibility to consumer complaints.

The concept of sensitive skin arose in the 1970s with the observation that despite the fact that previous safety evaluations had found no evidence of toxicity, some patients reported stinging sensations upon using a particular sunscreen that contained a derivative of *P*-aminobenzoic acid (8). Growing consumer awareness of the potential for irritation from common products fueled a huge increase in products marketed for the supposedly rare individual with susceptibility to components of everyday products, particularly since no requirement for proof of safety and efficacy for such products has existed (9). The initial conceptualization of sensitive skin as a minority complaint, has not been borne out by epidemiological surveys, which consistently find a high prevalence of sensitive skin across the industrialized world (Table 8.1). Rates of skin sensitivity have increased steadily over time, particularly among men (3).

A previous overview of sensitive skin (17) found little consensus on the definition of the disorder or even whether or not it truly exists as a physiological phenomenon. Since then the term has come to define an onset of prickling, burning, or tingling sensation due to ultraviolet (UV) light, heat, cold, wind, cosmetics, soap, water, pollution, stress, or endogenous

hormones (12), often with the frequent or prolonged use of everyday products such as cosmetics or toiletries (18). Itching, burning, stinging, and tightness are the most common subjective complaints (9), which have been reported mainly by women (9). Sensory effects are only occasionally accompanied by erythema (12).

Although sensitive skin is now generally accepted as a real physiological disorder, there is still no consensus regarding its etiology, classification, or criteria for diagnosis. To date much of the research has been published in cosmetic journals (inaccessible through major databases), and ignored by leading dermatological publications (9). Medical researchers have largely ignored consumer reports of sensory irritation because they are difficult to quantify and frequently are unaccompanied by visible signs (19).

Other issues have hindered a better understanding of this condition. It is typically self-diagnosed (20). Patients may interpret an underlying dermatological condition as well as any reaction to product use as sensitive skin (5); there are also some psychological disorders characterized by similar symptoms (e.g., cosmetic intolerance syndrome, dermatological nondisease) (21). Many people who profess sensitive skin do not predictably experience visible signs of the sensations reported, whereas some who describe themselves as nonsensitive react strongly to tests of objective irritation (22). Irritant testing reveals profound interpersonal variability in individual response to specific irritants (23,24), even among chemicals with similar modes of action (18).

Testing has showed sizeable variation within the same individual at different anatomic sites (24), and even at the same anatomical site on symmetric limbs (25). The diversity of methodology approaches employed in sensitive-skin research has also contributed to interpretive difficulties.

The etiology of sensitive skin is unknown, but the disorder is believed to be the result of either an increased permeability of stratum corneum or an acceleration of nerve response (26). Increased permeability is believed to be the result of a functional compromise of barrier function in the sensitive-skin patient (27). Barrier function has been shown to be a critical component of skin discomfort (28).

Lipid content of the stratum corneum has been shown to be a more accurate predictor of skin permeability than stratum corneum thickness or cell number (24). The permeability barrier in the stratum corneum requires the presence of well-organized intracellular lipids (20,28) and depends highly on lipid composition (24). Increased neutral lipids and decreased sphingolipids are associated with superior barrier properties (24). A weak barrier inadequately protects nerve ending and facilitates access to antigen presenting cells, a mechanism, which would support an association with atopic conditions (28). Irritation



**Table 8.1** Prevalence of Sensitive Skin Perception in the Industrialized World

Population(s) studied	Population characteristics	Definition of sensitive skin	Percentage of people who claimed sensitive skin	References
Japan, United States, Europe (1992) <sup>a</sup>	15,000 men and women, conducted by questionnaire	People whose skin reacts to particular insults more than the majority of people	50% women (25% very sensitive skin) 30% men	10
France (2000)	319 women, conducted by interviews	Cutaneous discomfort in the absence of clinical and histological evidence of skin lesions	90% (23% very sensitive skin)	8
England (2001)	3300 men and women, conducted by mailed questionnaire	Intolerance to cosmetics and toiletries, including both sensory and visible signs	51.4% men (5.8% very sensitive skin) 38.2% women (10% very sensitive skin)	6
United States (San Francisco, 2002)	800 women, conducted by telephone interview	Sensitive facial skin	52%	2
United States (Cincinnati, 2009)	1039 men and women, surveyed by questionnaire	Sensitive skin	68.4% of population reported some degree of sensitivity (69.0% of women, 64.4% of men)	3
France (2008)	18 women, identified by questionnaire	Sensitive skin	50% (facial skin specifically)	11
France (2008)	400, identified by questionnaire	Sensitive skin?	85% (facial skin specifically)	12
France (2005)	1006 men and women, identified by questionnaire	Sensitive skin	59% women, 44% men	13
France (2006)	8522 men and women, identified by questionnaire	Sensitive skin	61% women, 32% men	14
Greece, women (2008)	25, identified by questionnaire.	Sensitive skin	64%	7
Greece, women (2008)	25 women with atopic dermatitis	Sensitive skin	100%	7
Germany, men and women (2001)	420	Sensitive skin	75% (48% severe)	15
Italy, women (2005)	1870	Sensitive skin	56.5%	16

<sup>a</sup>Year of publication, not year of the study.

results from the abnormal penetration in skin of potentially irritating substances and a resulting decrease in the skin tolerance threshold (20).

Alterations in barrier function in sensitive-skin patients have been observed (29,30). Alterations of baseline capacitance values imply barrier impairment and support the view that hyperreactivity to water-soluble irritants results from increased absorption (31). A derangement of intercellular lipids, specifically, was also associated with a decline in barrier function in sensitive skin (32). The pain sensations, which are the hallmark of the disorder, also imply possible integration dysfunctions in the central nervous system.

Of the two studies reviewed that did evaluate the relationship between neurosensory responses and objective clinical irritation and included only subjects with demonstrated sensory sensitivity, both showed a correlation between sensory and objective signs (29,30). In a study regarding sensitivity to facial tissue, which did not exclude nonsensitive individuals, sensory effects were demonstrated to be the most reliable measure of product differences (29,30).

Although no predictive value was demonstrated for any individual sensitivity when subjects were tested with a seven-irritant panel, a weak association between tests was demonstrated by statistical analysis of binomial probability (18). However, studies, which evaluated the association of barrier function and sensitivity, have yielded arguably the most conclusive results. A high baseline transepidermal water loss (TEWL) was associated with increased susceptibility to

numerous cutaneous irritants by numerous studies and a variety of assessment methods (25).

Most methods focused on objective assessment of physical effects to skin rather than the sensory effects reported (33), and few reports have quantified sensory effects or correlate sensory effects to degree of irritation. Most testing has included few subjects, and few have restricted subjects to those with demonstrated sensitivity (34). Few have attempted to evaluate the influence of endogenous hormones or lifestyle factors.

Ultimately, traditional irritant-testing methodologies have not proven to be good predictors of consumer response (1). Response to one irritant does not predict sensitivity to another, and has not correlated well with evaluation of objective signs (35).

## FACTORS IN SKIN SENSITIVITY

Numerous potential host factors (Table 8.2) undoubtedly play a role in experimental variability observed in sensitive skin. To date, no constitutional factors have been identified (26).

### Gender

Sensitive skin is self-reported far more often in women than in men (Table 8.1). There is biological plausibility for greater sensitivity, as thickness of the epidermis was observed to be greater in males than in females ( $p < 0.0001$ ) (50), and hormonal differences, which may produce increased inflammatory sensitivity in females, have also been demonstrated (25,51). Irritant

**Table 8.2** Possible Contributors to Sensitive Skin

Factor	References
Female sex	6
Hormonal status	36
Cultural expectations in technologically advanced countries	15
Fair skin, which is susceptible to sunburn	37
Susceptibility to blushing and/or flushing	6
Skin pigmentation	37
Thin stratum corneum	34,38–40
Decreased hydration of stratum corneum	20,41,42
Disruption of stratum corneum	37
Increased epidermal innervations	20,43
Increased sweat glands	38
Increase neutral lipids and decreased sphingolipids	44
Decreased lipids	31,45–48
High-baseline transepidermal water loss	25
Atopy	7,49

testing, however, generally finds no differences (24). A recent study, however, found, among 1039 subjects a 68.4% prevalence of self-reported sensitive skin, with no difference between men and women (3). It may be that with increased marketing of products for sensitive skin in men it has become more cultural acceptable for males to define themselves as having sensitive skin.

### Age

The physiological changes that occur as skin ages would predict an increased susceptibility to irritants (52). Existing studies, however, are ambiguous with regard to the influence of age on skin sensitivity. Clinical assessment of the erythematous response to irritants in older people suggest that susceptibility generally decreases with age (52). However, objective signs of irritation often show little correlation with the intensity of subjective complaints (52). A study of sensory perceptions of sensitive skin conducted on 1029 individuals in Ohio stratified subjects into four age groups (subjects under 30, subjects in their 30s, subjects in their 40s, and those over 50), and evaluated subjective data according to age (52).

Those over 50 were more likely to claim sensitive skin than younger adults, and more likely to perceive genital skin (to the exclusion of other body sites) to be more sensitive (52). Older adults also stated that their skin had become more sensitive over time (46%) (52). In a large Italian study that performed lactic acid sting tests on more than one hundred elderly subjects, the intensity of the stinging response was inversely proportional to age (16).

### Ethnicity

There are pronounced differences in skin structure depending on skin type (Table 8.3) and racial differences, with regard to skin susceptibility to irritants, are among the fundamental questions in dermatotoxicology (34). Two large epidemiological studies reported no observed racial differences in reporting product sensitivity (2,6). Most testing, however, has focused on Caucasian females (34).

Differences have been observed in sensory perceptions, although substantive conclusions are hard to provide. Asians have been reported to complain of unpleasant sensory responses more often than Caucasians, supported by the obser-

vation that a higher incidence of dropouts in a Japanese clinical study withdrew because of adverse skin effects as compared with those in Caucasian studies (38). There have also been reports of an increased sensory response, as well as speed of response in Asian subjects versus Caucasian in sensory testing (38). Another study, however, found fair-skinned subjects prone to sunburn had higher sensory responses to chemical probes than those with darker skin tones (37). No racial differences in innervation on an architectural or biochemical level have been observed (18).

Studies of racial differences with regard to irritants have yielded conflicting evidence. Although black skin was demonstrated to have greater potential for irritant susceptibility than white skin (24), another study found blacks to be less reactive than Caucasians (23). Asians seemed to be more reactive than Caucasians in some studies, and less in others, even within studies done under the same investigator and protocol (34). Tristimulus colorimeter assessment of skin reflectance observed that skin pigmentation was inversely associated with susceptibility to irritation (25), supported by the finding that irritant susceptibility to sodium lauryl sulfate (SLS) is decreased after ultraviolet B (UVB) exposure (tanning) (25).

Methyl nicotinate assessment of vasoactive response suggests that there may be genuine racial differences in permeability (57). Increased percutaneous absorption of benzoic acid, caffeine, and acetylsalicylic acid was demonstrated in Asians when compared with Caucasians, and decreased percutaneous absorption was observed in blacks (38).

More recent studies have observed that, while overall prevalence of skin sensitivity is similar across skin types and ethnic groups, there are some observable differences with regard to what triggers discomfort and how discomfort is experienced. Caucasians report visual effects more than African-Americans, while African-Americans are more likely to report sensory effects (35). In addition, African-Americans of both genders were more likely to report sensitivity in the genital area than other groups ( $p = 0.0008$ ) (3).

A study of 800 women in San Francisco enrolled two hundred subjects in each of four ethnic groups to interview by phone and found no significant difference in overall prevalence between ethnic groups studied. Euro-Americans, however, were found to have a relatively higher susceptibility to wind than other ethnic groups, Asians had significantly higher sensitivity to spicy food, and Hispanics had relatively less reactivity to alcohol (2).

### Cultural Factors

Cultural factors may play a role. Fastidious cleansing routines (with douches, perfumes, medication, antifungal medications, and contraceptives), which often precede irritation (51), undoubtedly have some cultural component. Hygiene practices are the most common cause of vulvar irritation (51).

However, that confounding lifestyle factors should be considered with regard to some observed differences, as cultural practices may produce widely different exposures to potential irritants (26). For example, older women were found to be more likely to report irritation due to incontinence products than younger women, who were more likely to report irritation due to tampons (52). Air conditioning is more likely to be reported as a trigger for sensitive skin in July than in March (13,80). These findings are quite likely to be based on increased levels of exposure than on actual physiological differences.

**Table 8.3** Comparison of Racial Differences in Functional Skin Properties

Skin property	Types	Racial differences	References
Permeability	In vitro penetration of fluocinolone acetonide	Lower in blacks than in Caucasians	53
	In vitro penetration of water	No differences	53,54
	Topical application of anesthetic mixture	Less efficacy in blacks than in Caucasians	55
	In vivo penetration of C-labeled dipyrithione	Lower in blacks (34% lower) than in Caucasians	56
	Methyl nicotinate-induced vasodilation	Time to peak response equal than Caucasians Slower in blacks	57–59
TEWL	Baseline TEWL (in vitro)	Higher in blacks Higher in blacks (in vitro)	57,60
	TEWL in response to SLS irritation (in vivo)	Higher in blacks and Hispanics	42
	Baseline TEWL (in vivo)	Blacks > Caucasians > Asians	61
	Return to baseline TEWL after tape stripping	Blacks faster than whites	62
	Reactivity to SLS (measured by TEWL)	Higher in blacks than in Caucasians	60
Skin irritant reactivity	Reactivity to dichlorethylsulfide (1%)	Lower in blacks (measured by erythema, 15% vs. 58%) than in Caucasians	63
	Reactivity to o-chlorobenzylidene malonitrile	Lower, longer time to response in blacks than in Caucasians	64
	Reactivity to dinitrochlorobenzene	Lower in blacks, but trend toward equalization after removal of stratum corneum than Caucasians	65
	Reactivity to octanoic acid, 20% SLS, 100% decanol, 10% acetic acid	Asians more reactive than Caucasians (react more quickly)	66
	Stinging response	Lower in blacks than in whites Equal in blacks and whites Higher in Asians than in whites	38,67–69
Stinging response	UV protection factor of stratum corneum	Higher in blacks (about 50% higher) than in Caucasians	70
Skin transparency	UVB transmission in stratum corneum	Lower in blacks (about 50% lower)	70
	Spectral emittance	Lower in blacks (above 300 nm: 2–3 fold)	71
	UV protection factor of epidermis	Higher in blacks (4 fold)	70
	UVA transmission through epidermis	Lower in blacks (almost 4 fold)	70
	UVB transmission through epidermis	Lower in blacks (4 fold)	70
	Contribution of malpighian layer	Black skin: twice as effective in absorbing UVB as white skin	70
Photoprotection of epidermis	Skin extensibility on dorsal (sun-exposed) and volar (sun-protected) forearms	Black skin maintains extensibility on sun-exposed sites, but Hispanic skin extensibility is reduced on sun-exposed sites	72
Consequence of photoaging	Elastic recovery	Black skin maintains recovery on sun-exposed sites, white and Hispanic skins reduced	72
	Drying	Higher in Caucasian and Asians than in Hispanics and blacks	73
Response to insult	Hypertrophic scarring	Higher in Asians than in Caucasians	74
	Pigmented dermatoses	Higher in Asians than in Caucasians	74,75
	Wrinkling	Average onset is 10 yr later in Asians than in Caucasians	75
Somatosensory function	Wrinkling	Average onset 20 yr later in blacks than in Caucasians	76
	Thermal tolerance	Blacks have a lower threshold than whites	77
	Elastic recovery (tested on the cheek)	1.5 times greater in black as compared with white subjects	78,79

*Abbreviations:* SLS, sodium lauryl sulfate; TEWL, transepidermal water loss; UV, ultraviolet; UVA, ultraviolet A; UVB, ultraviolet B.

## Environmental Factors

A majority of sensitive-skin sufferers report unpleasant sensory responses to cold temperatures, wind, sun, pollution, and heat (2,20). An increased susceptibility to SLS was observed in the winter compared with the summer (25). Low temperatures and humidity characteristic of winter cause lower water content in the stratum corneum (25). Large-scale epidemiological testing in France conducted phone interviews of over 1000 people each in March and then in July, and observed the frequency of

sensitive skin in women to be significantly higher in summer than in winter: (71.2% in July vs. 59.39% in March) (13).

Numerous other host factors that could influence skin sensitivity include unusual occupational or leisure exposures to chemicals and home climate-control measures (35). Long-term or excessive use of personal-care products can also create sensitivities (20). Daily topical use of corticosteroids has been demonstrated to produce fragile skin (20), and excessive use of topical medications has been demonstrated to be the source of

up to 29% of vulvar dermatitis (81). Drug-induced sensitivity is also possible, although no reports on that issue were uncovered. Interestingly, the thickness of the epidermis, in one study, was demonstrated to be inversely proportional to the number of years that the subject had smoked, with a  $p = 0.0001$  (50).

The specific methodologies and conditions involved in the testing of skin sensitivity introduce a significant amount of variability into the published results; however, a recent study reveals that parameters of the testing can themselves induce sensitivity apart from that of the specific irritant employed. Sahlin et al. (82) evaluated the sting potential of the vehicle used in testing the adverse stinging reaction related to lactic acid application. The results showed that the ordinary oil-in-water emulsion induced stinging in and of itself; use of a water-in-oil emulsion created less discomfort. It was also observed that decreasing the mineral oil content in the oil-in-water emulsion resulted in decrease in the degree of sting experienced (82).

### Anatomic Site

Differences in skin sensitivity between anatomical regions have been observed. Analysis of structural differences found that stratum corneum density varies tremendously by anatomical site—palms and soles are the thickest, whereas the genital area is the thinnest (83). The rate of turnover in the stratum corneum, 10 days in facial areas, is longer elsewhere (83,84).

The face is the most common site of skin sensitivity. In a study of 1039 men and women, 77.3% reported facial sensitivity, compared with 60.7% for the body, and 56.2% specifically with regard to genital skin (3). Saint-Martory also found the face to be the most commonly reported site of sensitivity, with hands, scalp, feet, neck, torso, and back also reported, in order of frequency (12). The nasolabial fold has been reported to be the most sensitive region (18) of the facial area, followed by the malar eminence (18), chin, forehead, and upper lip (12,18). Misery et al. (2008) found 44.22% of sensitive-skin subjects questioned experienced sensitivity of the scalp (85). Factors contributing to facial sensitivity are likely the number of products used on the face (particularly in women), a thinner barrier in facial skin, and a plentitude of nerve endings as well (21). Individual susceptibility appears to be dependent on anatomical site (86). Most studies have been conducted in facial skin because of its sensitivity [stinging sensations, particularly, are readily elicited on facial skin (87)] and the fact that it is readily accessible for both visual (88) and biophysical assessments (31).

The vulva is an area of particular interest, since it is formed partially from embryonic endoderm; it differs from skin at exposed body sites (22). Differences in irritation seem to be dependent on relative permeability of the irritant in vulvar skin; vulvar skin is significantly more reactive than forearm skin to benzalkonium chloride and maleic acid (36), but less reactive than the forearm to SLS (22). When both venous blood and menses were evaluated for irritant potential, the vulva was less responsive to both than was the upper arm (89).

Nonkeratinized vulvar skin exhibits clearly increased permeability related to the absence of keratin and loosely packed, less structured lipid barrier (22). In addition, the inner epithelia are thinner, representing a shorter distance to penetrate (22). Buccal tissue is often employed in a surrogate model for vulvar testing, as it has very similar structure and biochemistry (22). Buccal skin has been demonstrated to be 10 times more permeable than keratinized skin (90).

Although the vulvar area may be particularly susceptible to cutaneous irritation (91), little objective published data exists

on the relationship between feminine hygiene products and sensitive skin (87). Irritant reactions to feminine-care products have been reported (81) with a few feminine products that contain chemicals known to be irritants in certain doses (92). However, the potential for heightened vulvar susceptibility to topical agents is not widely reported in literature (22). The contribution to irritation by topical agents, though, is substantial (23,25) and often underestimated (51). In fact, 29% of patients with chronic vulvar irritation were demonstrated to have contact hypersensitivity, and 94% of those were determined to have developed secondary sensitization to topical medications (81). Thus, reported sensitivity in the vulvar area, may often be related to underlying contact hypersensitivity because of excessive use of topical hygienic and medicinal preparations (4).

Recent studies have evaluated skin sensitivity in the vulvar area with regard to sensory responses to consumer products meant for the vulvar area. It was hypothesized that patients with erythema related to a previous genital infection may represent a population of sensitive subjects; however, no increase in sensory effects to exposure to feminine hygiene pads was observed (87).

In a similar population, however, in which observed erythema was evaluated against perceived sensory effects, women who perceived themselves as particularly susceptibility to facial erythema were significantly more likely to have medically diagnosed vulvar erythema, a potential indicator of a underlying biological origin (87).

Interestingly, a separate study evaluated perceptions of sensitive skin in women with urinary incontinence, expecting to observe an increased sensitivity of genital skin (93). Increased sensitivity specific to the genital area was not observed, but incontinent women were significantly more likely to assess themselves as having overall skin sensitivity than continent subjects ( $p = 0.014$ : 86.2% in incontinent subjects vs. 68.3% in controls) (93).

### SENSORY EFFECTS AND OBJECTIVE SIGNS

It was observed early on that some subjects report a greater incidence of adverse reactions to certain products because of higher sensitivity (2,6,18,31,34). Some individuals possess exaggerated sensitivity to specific individual irritants (37). Despite the fact, however, that studies have demonstrated that sensitive-skin patients are capable of distinguishing products on the basis of blinded sensory endpoints (18,33), a clinically satisfactory description of observed sensitivities remains out of reach.

Tantalizing clues to the underlying mechanisms of sensitive skin, however, continue to be reported. If deficits in barrier function do play a role in skin sensitivity, regular use of moisturizer should improve sensitivity; patients who completed four of daily treatment with moisturizer improved (5). Evaluation of the potential role of the stratum corneum in sensitive skin using corneosurfametry demonstrated that subjects with demonstrated sensitivity to detergents had an increased reactivity to tested products as compared with the control group. It may be a specific subgroup of sensitive skin with some sort of defect in the stratum corneum that caused weakened resistance to surfactants (29).

Local anesthetics block response in lactic acid sting tests; stingers respond more vigorously to vasodilators (21). An Italian study compared self-reports of sensitivity with response in the lactic acid test as follows: stingers were found at very

similar prevalences to self-reported sensitivity (56.9% of women perceived skin as sensitive, 54.3% revealed to be stingers). In addition, those who believe skin to be sensitive were revealed to be more likely to be stingers (59%) than among nonstingers (48.9%) (16).

Simion, by exaggerated arm-washing with synthetic detergent bars, observed signs that correlated statistically with sensory perceptions (dryness, tightness, and itching). In addition, consumers were able to reproducibly distinguish between test products purely on the basis of sensory effects (19).

Another study evaluated specific biophysical parameters in 32 subjects medically diagnosed with sensitive skin in parallel with a nonsensitive-skin control group. Patch testing, skin hydration, sebum production, alkali resistance test, lactic acid sting test, methyl nicotinate 0.5%, acetyl- $\beta$ -methyl chloride 1:1000, pH, dermographism, and measurement of total and specific Ig were performed (30).

Patch testing found that patients with sensitive skin were ten times more likely to respond to allergens in the European standard series ( $p < 0.01$ ) and three times more likely to respond to cosmetic allergens ( $p < 0.01$ ) than those without sensitive skin (30). Sensitive subjects also had significantly less sebum production ( $p < 0.01$ ) and dryer skin ( $p < 0.05$ ). Sensitive patients had a four-fold risk of a decrease of alkali resistance ( $p < 0.05$ ) (30).

Vascular reactions to methyl nicotinate and acetyl- $\beta$ -methyl chloride in sensitive-skin patients were observed to be characterized by a significant hyperreaction of skin blood vessels, with a more intense erythema after methyl nicotinate application (30). The risk of an intense vascular reaction to methyl nicotinate was 75 times higher in sensitive patients than in nonsensitive subjects, and nearly one-third of sensitive-skin subjects experienced an abnormal vascular reaction (skin blanching) after application of acetyl- $\beta$ -methylcholine chloride (30). A strong association of sensitivity skin with fair skin was also observed (30). This may relate to well-established differences in skin structure and permeability across different skin types (30).

## **SENSITIVE SKIN: ZEROING IN ON BIOLOGICAL ORIGIN**

Part of the reason for the observed breakdown between sensory effects and objective signs is the fact that an objective sign like erythema is the end result of a complex, multistep physiological process. Numerous underlying processes (e.g., changes in blood flow, moisture content, pH) would be expected to occur before the appearance of visible external changes (1).

A goal of our research has been to increase the ability to predict and quantify these subjective consumer responses. Our approach has been three fold: to exaggerate testing conditions to elicit corroborating physical findings, to increase the sensitivity of assessment of physical findings, and to find a way to quantify sensory endpoints (1).

## **Exaggeration of Test Conditions**

One study evaluated four versions of facial tissues, with and without coating, with repeated wiping to accentuate irritation. Affected skin had been compromised by tape stripping prior to wiping protocol initiation. Erythema, as well as dryness, were evaluated daily by trained graders. In addition, panelists were also interviewed about specific aspects of product preferences. Statistical analysis revealed that the panelists' subjective product preferences were more consistent in distinguishing between the test product than were either erythema or dryness (92).

A second method of accentuating test conditions, developed in our laboratories specifically for testing paper such as catamenial products, has proven very effective at accentuating irritant response to inherently mild products. The behind-the-knee (BTK) protocol uses the popliteal fossa as a test site and adds a relevant mechanical friction component to old testing. BTK testing consists of a test product placed behind the knee and held securely by an elastic knee band.

Levels of irritation produced in BTK testing are consistently higher than those achieved with standard patch testing, and have proven to be consistently reproducible (94). BTK testing, in conjunction with the other two approaches below, has proven useful in the development of potentially valuable protocols for sensitive-skin testing.

## **Quantifying Sensory Responses**

A study similar to the facial tissue study above tested feminine hygiene products according to four combinations of test conditions (wet/dry, intact/compromised skin). Products tested were inherently nonirritating and were tested in parallel in arm patches and BTK. In addition, the study evaluated observed erythema grading against a patient log of sensory effects. Although no differences were observed between any combinations tested, a significant correlation of reported sensory discomfort with mean irritant scores was observed. Skin sites where patients experienced burning, itching, or sticking had consistently higher mean irritant scores (95). Ultimately, eight separate comparison studies were able to statistically associate perceived sensory effects with an increase in irritant scores (94).

Companion papers that utilized only BTK methodology (96) but also evaluated patient diaries in conjunction with the irritant testing also observed correlation between sensory effects and mean irritant scores (95).

## **Increasing Sensitivity of Assessment of Physical Response**

Our laboratories evaluated several new methodologies in the pursuit of an increased sensitivity of the evaluation of the physical response. Visual grading of erythema has been relied on for a number of years; trained graders achieve a high degree of reproducibility with no specialized equipment. A new approach in our laboratories, however, utilized cross-polarized light, which allows visualization of the skin at a depth of 1 mm below the surface. Testing was performed with SLS in a standard patch test, and with two different feminine hygiene products (identified as A and B) behind the knee. With minor irritation produced by low-level SLS, subsurface visualization provided no improvement over visual scoring. In BTK subjects, however, enhanced visual scoring through subsurface visualization allowed the observation of significant differences in the irritation produced by the two different products, differences that were visible on the first day (97). Enhanced visual scoring was used successfully with both traditional patch testing and BTK (with SLS and catamenial pads) and provides a first link between sensory and physiological effects. We also investigated this tool in the genital area of symptomatic patients. Results concluded that enhanced visualization of the genital epithelial subsurface with cross-polarized light may assist in diagnosing subclinical inflammation in vulvar conditions heretofore characterized as sensory syndromes.

Further research combined the BTK-testing approach with enhanced visualization. Using enhanced visualization,

subclinical changes were observable after initial exposure; and enhanced visualization was able to correlate subclinical effects on skin to previously established consumer preferences between two products, a correlation that had not been verifiable in prior testing (33).

A second approach evaluated the potential for changes in skin temperature related to inflammation to act as a subclinical measure of skin irritation. Previous research has demonstrated a correlation between surface temperature measurements and inflammatory response (98). A high precision, handheld infrared thermographic scanner, recently developed, makes it feasible to conveniently measure local changes in skin temperature in situ (99).

Two catamenial products were compared in a BTK protocol. Skin surface temperature was measured using an infrared thermographic scanner. Subjects were also asked to keep a diary of skin discomfort experienced at test sites, specifically including sticking, chafing, burning, itching, pain, edema, or any other issue. Skin temperature changes observed were closely associated with visual scores. In addition, the study incorporated diary-derived data on sensory effects experienced by panelists as an additional endpoint. The diaries of subjective sensory experiences over the course of the exposure made a clear distinction between the two test products that was consistent with both visual scoring and skin temperatures. A significant t-difference was also observed between mean visual scores of those who reported specific adverse sensations as compared with those who did not report negative sensations. Skin temperature means were significantly higher for those who reported the adverse sensations rubbing and chafing (interestingly, burning sensations were not associated with increase in skin surface temperature). Conditions in this protocol were optimized for using erythema as the primary endpoint; refining the protocol to optimize detection of differences in skin surface temperature would be a logical next step. Skin surface temperatures correlated well with visual signs of irritation, six of eight sensory effects were associated with higher visual scores (99).

An additional new technique in development uses a commercially available product called Sebutape<sup>®</sup> (CuDerm Corporation, Dallas, Texas, U.S.), an absorbent tape, which is applied to skin for 60 seconds and then removed. Application of the tape to both healthy skin and compromised skin was followed by extraction of different cytokines from the Sebutape, which were then quantified. Levels of IL-1 $\alpha$ , IL-1RA, and IL-8 were evaluated. Compromised skin was associated significantly with increased IL-1 $\alpha$  levels, increased IL-8 levels, and increased IL-1RA/IL-1 $\alpha$  ratio. This technique has not been substantially applied to the problem of sensitive skin as yet, but shows potential (100).

### Links Between Sensitive Skin and Immunology

Evidence for a link between atopy and sensitive skin has accumulated (49). In an assessment of 1039 individuals (83.6% female) found that individuals who claimed overall to have sensitive skin were 5 times likely to have skin allergies confirmed by a doctor ( $p < 0.0001$ ) (49) and also more than 3.5 times more likely to have relatives with sensitive skin (49). A large early epidemiological study in the United Kingdom also observed the incidence of sensitive skin to be higher in subjects with sensitive skin (6). In a study in older adults, those who claimed sensitive skin had a higher frequency of

medically diagnosed skin allergies than younger people who claimed sensitive skin (52). Löffler et al. (2001) observed a link between sensitive skin and nickel allergy (15).

A study compared 25 Greek women with medically diagnosed atopic dermatitis with 25 healthy women. A significant association was found between the clinical diagnosis of atopic dermatitis and the self-diagnosis of sensitive skin ( $p < 0.001$ ). All patients in the atopic dermatitis group described themselves as having sensitive skin to at least some degree, with 80% claiming either moderately or very sensitive. By contrast, 64% of individuals in the control group described their skin as sensitive to some degree, with only 16% claiming either very or moderately sensitive (7). Patients with atopic dermatitis were also significantly more likely to indicate a family history of sensitive skin than were nonsensitive individuals (68–24%,  $p = 0.004$ ) 76% of atopic patients who claimed a family history identified a parent as having sensitive skin (7).

Atopic individuals were significantly more likely to report genital sensitivity after contact with hygiene pads, although not more likely to experience sensitivity to genital cleansing products, fragrances, or antiperspirants (7). In addition, the study demonstrated a link between clinically diagnosed atopic dermatitis and sensitive skin, with the frequency, severity, and history of skin sensitivity in patients with atopic dermatitis far more pronounced than in controls (7). This link has substantial biological plausibility, as contact allergy and skin sensitivity are phenomena that share similar cytokine inductions (49).

Of potential utility for large-scale screening in industry, postmarket surveillance, and epidemiological testing, a rapid algorithm containing only three questions has been developed. Testing of the algorithm in a capable of identifying 88% of atopic individuals out of a population of sensitive-skin patients (101).

### Insight into Neurogenic Causality

Sensitive skin is predominantly sensory in nature and thus ultimately a neurological disorder. Sensory differences may be related to innervation (43). Dermal nerve fibers extend throughout viable epidermis as free nerve endings, but the epidermal component of this network is still poorly characterized (43). Epidermal nerve density variation could explain the different sensitivity thresholds in various anatomical sites (102). Hyper-reactivity of the neural response of the skin is postulated to play a role. Possible mechanisms for neural system hyper-reactivity include nerve fibers; endothelin receptors; burn, itch and heat receptors; cold receptors; and neutrophins (26).

Neurogenic inflammation probably results from release of neurotransmitters such as substance P, calcitonin gene-related peptide, and vasoactive intestinal peptide, which induce vasodilation and mast cell degranulation. Nonspecific inflammation may also be associated with the release of interleukins (IL-1, IL-8, prostaglandin E2, prostaglandin F2, and tumor necrosis factor  $\alpha$ ) (85). Recent studies have evaluated what contribution neural dysfunction may play in the development of sensitive skin.

Functional magnetic resonance imaging (MRI), which measured cerebral activation associated with skin discomfort, was used to evaluate neural reaction to application of lactic acid to the face in 18 women, with and without sensitive skin. Lactic acid-induced skin discomfort resulted in increased activity in the primary sensorimotor cortex contralateral to the application site as well as in a bilateral frontoparietal network that included

the parietal cortex, prefrontal areas around the superior frontal sulcus, and the supplementary motor activity. In addition, in sensitive-skin patients only, group activity spread into the ipsilateral primary sensorimotor cortex and the bilateral peri-insular secondary somatosensory area, a phenomenon, which did not occur in the control group. Subjects with self-assessed sensitive skin were also observed to have significantly large greater increases in neural activity than those without sensitive skin, demonstrating an increase in neural activity specifically associated with sensitive skin (11).

Another study measured calibrated electrical stimulation of the skin, which stimulates sensory nerve fibers such as the myelinated A fiber, A delta fiber and unmyelinated c-fiber independently. In subjects with clinically documented sensitive skin (lactic acid sting test, cosmetic compatibility tests) versus nonsensitive controls (all subjects male), nerve fibers were stimulated by three different current strengths, and capsaicin (0.075%) was applied to the zygomatic arch. Sensory perception was verbalized by the subject and recorded. Baseline perception of current revealed no significant differences between sensitive and nonsensitive subject at either 2 kHz or 250 Hz, but at 5 Hz (a current known to selectively stimulate the c-fibers of sensory nerves), sensitive-skin subjects displayed a significantly lower perception threshold. In addition, stimulation of the skin by capsaicin, in nonsensitive subjects, had no effect on perception of the 5-Hz current, whereas sensitive subjects displayed a long-lived increase in the sensory perception

threshold (still in place at last time point of 60 minutes). These findings imply that sensory perception in sensitive subjects is easily disturbed by weak stimulation, inducing a wide variability of response compared with nonsensitive subjects, an effect that appears to be c-fiber modulated. The study was conducted in only eight subjects (four with sensitive skin) and should be followed up in a larger population (103).

### CONCLUSION: A VALID SYNDROME WITH MULTIPLE ORIGINS?

Sensitive skin, though now largely recognized as genuine syndrome of physiological origin, is still a subjective complaint with no consistent associations (15), no likely etiologies defined (28), no predictable or classical visible signs of irritation, no immunological verifiable response and no accepted and reproducible diagnostic test (26). Although it is clear that specific individuals clearly have heightened sensitivity to different kinds of sensory and physical irritants, observed reactions are not predictive of generalized sensitivity, and the relationship between observed sensitivities is unclear (14,33). Evidence suggests that sensitive skin may not be a single condition, but one that encompasses different categories of subjects and sensitivities based on different mechanisms (31)—not a single entity, but a heterogeneous syndrome (9). Multiple etiologies would not be farfetched, as the nervous system does not act in isolation but is interdependent with both the immune system

**Table 8.4** Some Methodologies Used for Sensitive Skin

Methodology	Sensory affect evaluated	Physical effect evaluated	Relevant irritants	Advantages	Disadvantages
Lactic acid (5)	Stinging	None	Cosmetics, other personal preparations meant to be left on	Highly sensitive and specific <sup>a</sup>	Does not predict sensitivity to other irritants
Capsaicin (26)	Stinging	None	Cosmetics, other personal preparations meant to be left on	Sensitive, detection threshold well correlated (inversely) to perception of sensitive skin	Does not predict sensitivity to other irritants
Sodium lauryl sulfate (25)	Burning	Erythema	Industrial exposures, cleaning products	Cheap, quick, reliable assessment of individual susceptibility to specific irritant	Sensitivity to one irritant not predictive of general sensitivity, relationship to sensitive skin in question
Cross-polarized light (97)	None	Subclinical erythema	Any potential irritant	Permits detection of physical changes not apparent by standard visual scoring, noninvasive	Requires specialized equipment
Thermoscan (99)	None	Temperature increases resulting from inflammatory processes related to skin injury	Any potential irritant	Noninvasive, objective, quantitative	Requires specialized equipment
Sebutape <sup>®</sup> (100)	None	Measurement of cytokines produced by injured skin	Any potential irritant	Noninvasive, objective, quantitative, potentially very sensitive	Requires training, specialized equipment; utility for sensitive skin still unassessed

<sup>a</sup>Lactic acid test positive in 90% of women who claim sensitive skin.

Source: From Ref. 5.

and the skin, sharing numerous cellular contact as well as the same language of cytokines and neurotransmitters. All three interact to affect cutaneous responses (30).

There is an urgent necessity to establish methodologies with the capacity to accurately identify sensitive skin (9), independent of self-assessed reports (26). Methods are needed that are capable of detecting very subtle skin benefits or potential for adverse effects. Testing has been done primarily on normal subjects, bringing into question the need to focus on examining populations that may be sometimes inherently more sensitive to irritant effects (22). Some studies did compare the irritation potential of products between self-declared sensitive-skin to nonsensitive-skin subjects (104,105). A summary of current methodologies used to identify sensitive skin is shown in Table 8.4.

Subclinical irritation may be the key to understanding sensitive skin (19), as sensations elicited by product exposure are generally discerned long before observable differences (19). One significant advance in the understanding of sensitive skin is the development of new, noninvasive techniques, for example, cross-polarized light-enhanced visualization, which has demonstrated good correlation with sensory perceptions and the ability to measure subclinical damage (97).

An immediate need is to build on what is known with improved techniques, carefully crafted protocols that evaluate appropriate exposures and study populations, and rigorous methodological and statistical procedures, bringing the study of sensitive skin out of the realm of fairy tales and into the realm of a genuine physiological disorder worthy of focused research. The challenge of the future is to unravel the biological link between subjective clinical signs and their physical sequelae as a means to develop appropriate diagnostic criteria as well as to understand the etiology of this still largely mysterious disorder.

## REFERENCES

- Farage MA. Are we reaching the limits or our ability to detect skin effects with our current testing and measuring methods for consumer products? *Contact Dermatitis* 2005; 52:297-303.
- Jourdain R, de Lacharrière O, Bastien P, et al. Ethnic variations in self-perceived sensitive skin: epidemiological survey. *Contact Dermatitis* 2002; 46:162-169.
- Farage MA. How do perceptions of sensitive skin differ at different anatomical sites? An epidemiological study. *Clin Exp Dermatol* 2009; 34(8):e521-e530.
- Singer N. Face it, princess, your skin is probably quite common. *New York Times*. October 13, 2005. Available at: <http://www.nytimes.com/2005/10/13/fashion/thursdaystyles/13skin.html>. Accessed May 15, 2009.
- Kligman A. Human models for characterizing "sensitive skin." *Cosmet Dermatol* 2001; 14:15-19.
- Willis CM, Shaw S, De Lacharrière O, et al. Sensitive skin: an epidemiological study. *Br J Dermatol* 2001; 145:258-263.
- Farage M, Bowtell P, Katsarou A. Self-diagnosed sensitive skin in women with clinically diagnosed atopic dermatitis. *Clin Med Dermatol* 2008; 2:21-28.
- Morizot F, Guinot C, Lopez S, et al. Sensitive skin: analysis of symptoms, perceived causes and possible mechanisms. *Cosmet Toilett* 2000; 115:83-89.
- Kligman AM, Sadiq I, Zhen Y, et al. Experimental studies on the nature of sensitive skin. *Skin Res Technol* 2006; 12:217-222.
- Johnson A, Page D. Making sense of sensitive skin. Yokohama, Japan: Congress of the International Federation of Society of Cosmetic Chemists. Poster 700, 1992.
- Querleux B, Dauchot K, Jourdain R, et al. Neural basis of sensitive skin: an fMRI study. *Skin Res Technol* 2008; 14:454-461.
- Saint-Martory C, Roguedas-Contios AM, Sibaud V, et al. Sensitive skin is not limited to the face. *Br J Dermatol* 2008; 158:130-133.
- Misery L, Myon E, Martin N, et al. [Sensitive skin in France: an epidemiological approach]. *Ann Dermatol Venereol* 2005; 132:425-429.
- Guinot C, Malvy D, Mauger E, et al. Self-reported skin sensitivity in a general adult population in France: data of the SU.VI.MAX cohort. *J Eur Acad Dermatol Venereol* 2006; 20:380-390.
- Löffler H, Dickel H, Kuss O, et al. Characteristics of self-estimated enhanced skin susceptibility. *Acta Derm Venereol* 2001; 81:343-346.
- Sparavigna A, Di Pietro A, Setaro M. 'Healthy skin': significance and results of an Italian study on healthy population with particular regard to 'sensitive' skin. *Int J Cosmet Sci* 2005; 27:327-331.
- Farage MA, Katsarou A, Maibach HI. Sensory, clinical and physiological factors in sensitive skin: a review. *Contact Dermatitis* 2006; 55:1-14.
- Marriott M, Holmes J, Peters L, et al. The complex problem of sensitive skin. *Contact Dermatitis* 2005; 53:93-99.
- Simion FA, Rhein LD, Morrison BMJ, et al. Self-perceived sensory responses to soap and synthetic detergent bars correlate with clinical signs of irritation. *J Am Acad Dermatol* 1995; 32:205-211.
- Pons-Guiraud A. Sensitive skin: a complex and multifactorial syndrome. *J Cosmet Dermatol* 2004; 3:145-148.
- Chew A, Maibach H. Sensitive skin. In: Loden M, Maibach H, eds. *Dry Skin and Moisturizers: Chemistry and Function*. Boca Raton: CRC Press, 2000:429-440.
- Farage M, Maibach HI. The vulvar epithelium differs from the skin: implications for cutaneous testing to address topical vulvar exposures. *Contact Dermatitis* 2004; 51:201-209.
- Basketter DA, Wilhelm KP. Studies on non-immune immediate contact reactions in an unselected population. *Contact Dermatitis* 1996; 35:237-240.
- Cua AB, Wilhelm KP, Maibach HI. Cutaneous sodium lauryl sulphate irritation potential: age and regional variability. *Br J Dermatol* 1990; 123:607-613.
- Lee CH, Maibach HI. The sodium lauryl sulfate model: an overview. *Contact Dermatitis* 1995; 33:1-7.
- Ständer S, Schneider SW, Weishaupt C, et al. Putative neuronal mechanisms of sensitive skin. *Exp Dermatol* 2009; 18:417-423.
- Primavera G, Berardesca E. Sensitive skin: mechanisms and diagnosis. *Int J Cosmet Sci* 2005; 27:1-10.
- Muizzuddin N, Marenus KD, Maes DH. Factors defining sensitive skin and its treatment. *Am J Contact Dermatitis* 1998; 9:170-175.
- Goffin V, Piérard-Franchimont C, Piérard GE. Sensitive skin and stratum corneum reactivity to household cleaning products. *Contact Dermatitis* 1996; 34:81-85.
- Roussaki-Schulze AV, Zafriou E, Nikoulis D, et al. Objective biophysical findings in patients with sensitive skin. *Drugs Exp Clin Res* 2005; 31(suppl):17-24.
- Seidenari S, Francomano M, Mantovani L. Baseline biophysical parameters in subjects with sensitive skin. *Contact Dermatitis* 1998; 38:311-315.
- Ota M, Hikima R, Ogawa T. Physiological characteristics of sensitive skin classified by stinging test. *J Jpn Cosmet Sci Soc* 2000; 24:163-167.
- Farage MA, Santana M, Henley E. Correlating sensory effects with irritation. *Cutan Ocul Toxicol* 2005; 24:45-52.
- Robinson MK. Racial differences in acute and cumulative skin irritation responses between Caucasian and Asian populations. *Contact Dermatitis* 2000; 42:134-143.
- Farage MA. Perceptions of sensitive skin: changes in perceived severity and associations with environmental causes. *Contact Dermatitis* 2008; 59:226-232.
- Britz MB, Maibach HI, Anjo DM. Human percutaneous penetration of hydrocortisone: the vulva. *Arch Dermatol Res* 1980; 267:313-316.
- Farage MA, Stadler A. Risk factors for recurrent vulvovaginal candidiasis. *Am J Obstet Gynecol* 2005; 192:981-982; author reply 982-983.



38. Aramaki J, Kawana S, Effendy I, et al. Differences of skin irritation between Japanese and European women. *Br J Dermatol* 2002; 146:1052–1056.
39. Freeman R, Cockerell E, Armstrong J, et al. Sunlight as a factor influencing the thickness of epidermis. *J Invest Dermatol* 2006; 39:295–298.
40. Thomson M. Relative efficiency of pigment and horny layer thickness in protecting the skin of Europeans and Africans against solar ultraviolet radiation. *J Physiol (Lond)* 1955; 127: 236–246.
41. Corcuff P, Lotte C, Rougier A, et al. Racial differences in corneocytes. A comparison between black, white and oriental skin. *Acta Derm Venereol* 1991; 71:146–148.
42. Berardesca E, Maibach HI. Racial differences in sodium lauryl sulphate induced cutaneous irritation: black and white. *Contact Dermatitis* 1988; 18:65–70.
43. Marriott M, Whittle E, Basketter DA. Facial variations in sensory responses. *Contact Dermatitis* 2003; 49:227–231.
44. Lampe MA, Burlingame AL, Whitney J, et al. Human stratum corneum lipids: characterization and regional variations. *J Lipid Res* 1983; 24:120–130.
45. Reinertson R, Wheatley V. Studies on the chemical composition of human epidermal lipids. *J Invest Dermatol* 1959; 32:49–59.
46. Brod J. Characterization and physiological role of epidermal lipids. *Int J Dermatol* 1991; 30:84–90.
47. Elias P, Menon G. Structural and lipid biochemical correlates of the epidermal permeability barrier. In: Elias P, ed. *Advances in Lipid Research*. San Diego: Academic Press, 1991:1–25.
48. Swartzendruber DC, Wertz PW, Kitko DJ, et al. Molecular models of the intercellular lipid lamellae in mammalian stratum corneum. *J Invest Dermatol* 1989; 92:251–257.
49. Farage MA. Self-reported immunological and familial links in individuals who perceive they have sensitive skin. *Br J Dermatol* 2008; 159:237–238.
50. Sandby-Møller J, Poulsen T, Wulf HC. Epidermal thickness at different body sites: relationship to age, gender, pigmentation, blood content, skin type and smoking habits. *Acta Dermat Venereol* 2003; 83:410–413.
51. Farage MA. Vulvar susceptibility to contact irritants and allergens: a review. *Arch Gynecol Obstet* 2005; 272:167–172.
52. Farage MA. Perceptions of sensitive skin with age. In: Farage MA, Miller KW, Maibach HI, eds. *Textbook of Aging Skin*. Springer-Verlag Publisher, 2010:1027–1046.
53. Berardesca E, Maibach H. Racial differences in skin pathophysiology. *J Am Acad Dermatol* 1996; 34:667–672.
54. Bronaugh RL, Stewart RF, Simon M. Methods for in vitro percutaneous absorption studies. VII: use of excised human skin. *J Pharm Sci* 1986; 75:1094–1097.
55. Hymes J, Spraker M. Racial differences in the effectiveness of a topically applied mixture of local anesthetics. *Reg Anesth* 1986; 11:11–13.
56. Wedig JH, Maibach HI. Percutaneous penetration of dipyrithione in man: effect of skin color (race). *J Am Acad Dermatol* 1981; 5: 433–438.
57. Kompaore F, Marty JP, Dupont C. In vivo evaluation of the stratum corneum barrier function in blacks, Caucasians and Asians with two noninvasive methods. *Skin Pharmacol* 1993; 6:200–207.
58. Guy RH, Tur E, Bjerke S, et al. Are there age and racial differences to methyl nicotinate-induced vasodilatation in human skin? *J Am Acad Dermatol* 1985; 12:1001–1006.
59. Berardesca E, Maibach HI. Racial differences in pharmacodynamic response to nicotines in vivo in human skin: black and white. *Acta Derm Venereol* 1990; 70:63–66.
60. Wilson D, Berardesca E, Maibach HI. In vitro transepidermal water loss: differences between black and white human skin. *Br J Dermatol* 1988; 119:647–652.
61. Sugino K, Imokawa G, Maibach H. Ethnic difference of stratum corneum lipid in relation to stratum corneum function. *J Invest Dermatol* 1993; 100:587 (abstr 594).
62. Reed JT, Ghadially R, Elias PM. Skin type, but neither race nor gender, influence epidermal permeability barrier function. *Arch Dermatol* 1995; 131:1134–1138.
63. Marshall E, Lynch V, Smith H. Variation in susceptibility of the skin to dichloroethylsulfide. *J Pharmacol Exp Ther* 1919; 12:291–301.
64. Weigand D, Mershon M. The cutaneous irritant reaction to agent O-chlorobenzylidene malonitrile (CS); quantitation and racial influence in human subjects. Edgewood Arsenal, Number 4332, 1970.
65. Weigand DA, Gaylor JR. Irritant reaction in Negro and Caucasian skin. *South Med J* 1974; 67:548–551.
66. Robinson MK. Population differences in acute skin irritation responses. Race, sex, age, sensitive skin and repeat subject comparisons. *Contact Dermatitis* 2002; 46:86–93.
67. Foy V, Weinkauff R, Whittle E, et al. Ethnic variation in the skin irritation response. *Contact Dermatitis* 2001; 45:346–349.
68. Frosch P, Kligman A. A method for appraising the stinging capacity of topically applied substances. *J Soc Cosmet Chem* 1981; 28:197–209.
69. Grove GL. Physiologic changes in older skin. *Clin Geriatr Med* 1989; 5:115–125.
70. Kaidbey KH, Agin PP, Sayre RM, et al. Photoprotection by melanin—a comparison of black and Caucasian skin. *J Am Acad Dermatol* 1979; 1:249–260.
71. Anderson RR, Parrish JA. The optics of human skin. *J Invest Dermatol* 1981; 77:13–19.
72. Berardesca E, de Rigal J, Leveque JL, et al. In vivo biophysical characterization of skin physiological differences in races. *Dermatologica* 1991; 182:89–93.
73. Diridollou S, de Rigal J, Querleux B, et al. Comparative study of the hydration of the stratum corneum between four ethnic groups: influence of age. *Int J Dermatol* 2007; 46(suppl 1):11–14.
74. McCurdy J. Cosmetic surgery of the Asian face. In: Paper I, ed. *Facial Plastic and Reconstructive Surgery*. New York: Thieme, 2002:322–343.
75. Nouveau-Richard S, Yang Z, Mac-Mary S, et al. Skin ageing: a comparison between Chinese and European populations. A pilot study. *J Dermatol Sci* 2005; 40:187–193.
76. Kelly AP. Aesthetic considerations in patients of color. *Dermatol Clin* 1997; 15:687–693.
77. Edwards RR, Fillingim RB. Ethnic differences in thermal pain responses. *Psychosom Med* 1999; 61:346–354.
78. Rawlings AV. Ethnic skin types: Are there differences in skin structure and function? *Int J Cosmet Sci* 2006; 28:79–93.
79. Warriar A, Kligman AM, Harpert R, et al. A comparison of black and white skin using noninvasive methods. *J Soc Cosmet Chem* 1996; 47:229–240.
80. Misery L, Myon E, Martin N, et al. Sensitive skin: psychological effects and seasonal changes. *J Eur Acad Dermatol Venereol* 2007; 21:620–628.
81. Marren P, Wojnarowska F, Powell S. Allergic contact dermatitis and vulvar dermatoses. *Br J Dermatol* 1992; 126:52–56.
82. Sahlin A, Edlund F, Lodén M. A double-blind and controlled study on the influence of the vehicle on the skin susceptibility to stinging from lactic acid. *Int J Cosmet Sci* 2007; 29:385–390.
83. Tagami H. Racial differences on skin barrier function. *Cutis* 2002; 70:6–7; discussion 21–23.
84. Proksch S, Bel A, Puymirat E, et al. Does the human skeletal muscle harbor the murine equivalents of cardiac precursor cells? *Mol Ther* 2009; 17:733–741.
85. Misery L, Sibaud V, Ambronati M, et al. Sensitive scalp: Does this condition exist? an epidemiological study. *Contact Dermatitis* 2008; 58:234–238.
86. Green BG. Measurement of sensory irritation of the skin. *Am J Contact Dermatitis* 2000; 11:170–180.
87. Farage M, Bowtell P, Katsarou Z. The relationship among objectively assessed vulvar erythema, skin sensitivity, genital sensitivity, and self-reported facial skin redness. *J Appl Res* 2006; 6:272–281.

88. Vie K, Pons-Guiraud A, Dupuy P, et al. Tolerance profile of a sterile moisturizer and moisturizing cleanser in irritated and sensitive skin. *Am J Contact Dermatitis* 2000; 11:161–164.
89. Farage M, Warren R, Wang-Weigand S. The vulva is relatively insensitive to menses-induced irritation. *Cutan Ocul Toxicol* 2005; 24:243–246.
90. Squier CA, Hall BK. The permeability of skin and oral mucosa to water and horseradish peroxidase as related to the thickness of the permeability barrier. *J Invest Dermatol* 1985; 84:176–179.
91. Farage M, Stadler A, Elsner P, et al. Safety evaluation of modern feminine hygiene pads: two decades of use. *The Female Patient* 2004; 29:23–30.
92. Farage MA. Assessing the skin irritation potential of facial tissues. *Cutan Ocul Toxicol* 2005; 24:125–135.
93. Farage M. Perceptions of sensitive skin: women with urinary incontinence. *Arch Gynecol Obstet* 2009; 280:49–57; [Epub December 14, 2008].
94. Farage MA. The Behind-the-Knee test: an efficient model for evaluating mechanical and chemical irritation. *Skin Res Technol* 2006; 12:73–82.
95. Farage MA, Meyer S, Walter D. Evaluation of modifications of the traditional patch test in assessing the chemical irritation potential of feminine hygiene products. *Skin Res Technol* 2004; 10:73–84.
96. Farage MA, Meyer S, Walter D. Development of a sensitive test method to evaluate mechanical irritation potential on mucosal skin. *Skin Res Technol* 2004; 10:85–95.
97. Farage MA. Enhancement of visual scoring of skin irritant reactions using cross-polarized light and parallel-polarized light. *Contact Dermatitis* 2008; 58:147–155.
98. Camel E, O'Connell M, Sage B, et al. The effect of saline iontophoresis on skin integrity in human volunteers. I. Methodology and reproducibility. *Fundam Appl Toxicol* 1996; 32:168–178.
99. Farage M. Surface skin temperature with dermatitis, in preparation.
100. Perkins MA, Osterhues MA, Farage MA, et al. A noninvasive method to assess skin irritation and compromised skin conditions using simple tape adsorption of molecular markers of inflammation. *Skin Res Technol* 2001; 7:227–237.
101. Farage MA, Bowtell P, Katsarou A. A pilot algorithm to identify patients likely to have atopic dermatitis. *Am J Clin Dermatol* 2010; 11(3):1–5.
102. Besné I, Descombes C, Breton L. Effect of age and anatomical site on density of sensory innervation in human epidermis. *Arch Dermatol* 2002; 138:1445–1450.
103. Kim S, Lim S, Won Y, et al. The perception threshold measurement can be a useful tool for evaluation of sensitive skin. *Int J Cosmet Sci* 2008; 30:333–337.
104. Farage M, Stadler A. Cumulative irritation patch test of sanitary pads on sensitive skin. *J Cosmet Dermatol* 2005; 4:179–183.
105. Farage MA, Maibach H. Cumulative skin irritation test of sanitary pads in sensitive skin and normal skin population. *Cutan Ocul Toxicol* 2007; 26:37–43.

## Hyaluronan (hyaluronic acid)

Birgit A. Neudecker, Robert Stern, and Howard I. Maibach

### ABSTRACT

Hyaluronan (hyaluronic acid, HA) is a straight chain non-sulfated glycosaminoglycan polymer and the predominant component of the extracellular matrix (ECM). HA is present in almost every vertebrate tissue with its highest concentrations occurring in the vitreous of the eye, in the synovial fluid of the joint capsule and in the umbilical cord. However, over 50% of the total body HA is present in skin (1).

In the past decades, hyaluronan has emerged surprisingly with a variety of new properties and functions, being not only a passive structural ECM component but profoundly effecting cellular metabolism as a critical regulator (2).

It is now well established that HA is synthesized by HA synthases (HAS) and degraded by hyaluronidases (Hyal), both of which are multigene families of enzymes with distinctive patterns of tissue expression. HA is an agonist of the cell surface receptor CD44 (3) as well as the HA-mediated motility (RHAMM), which is an intracellularly located receptor (4). Both exist in complex various isoforms affecting multiple signaling pathways (2).

Hyaluronan size is critical for its various functions. High molecular weight size reflects intact tissues, antiangiogenic, and immunosuppressive states, whereas smaller HA fragments are inducers of inflammation and angiogenesis (5), generally considered a stress signal.

HA also plays a key role in malignant progression, and the aggressiveness of tumors correlate with levels of HA on cancer cell surfaces (2).

Because of its extraordinary capacity to retain large amounts of water, it is responsible for the water content of skin, thus contributing in an important manner to the visual appearance of the skin. The biology of HA is different between dermis and epidermis. In dermis, levels do not diminish with age but instead become increasingly associated with tissues and resistant to extraction *in vitro* (6). Furthermore, HA plays a critical role in wound healing and aging processes. Chronic inflammation and sun damage caused by UV-light lead to changes in skin HA distribution and loss of skin moisture. Understanding the metabolism of HA and its interactions with other cellular and extracellular components will help to find new possibilities in modulating skin moisture and age-related skin changes.

### HYALURONIC ACID OR HYALURONAN—HISTORY

Hyaluronic acid (HA) is the predominant “mucopolysaccharide” of the skin and the major component of the extracellular matrix (ECM). Until the late 1970s, the old term “ground substance” was still used for the ECM, which was first attributed to an amorphous-appearing material between cells using light microscopy by the German anatomist Henle in 1841 (7).

It took until 1928, when Duran-Reynals (8–12) discovered a “spreading factor”: a testicular extract was shown to stimulate the rapid spreading of materials injected subcutaneously, and it functioned by causing dissolution of ground substance. The active principle in the extract was later shown to be a hyaluronidase, one of the class of enzymes that degrade HA.

In 1938, Karl Meyer (13) identified the substrate for the “spreading factor” as a hexuronic acid-containing material that also provided the turgor for the vitreous of the eye. He also proposed to use the term “mucopolysaccharides” to designate hexamine-containing polysaccharides that occur in animal tissues, referring to the sugar polymers alone, as well as when bound to proteins.

However, it required 20 years before the chemical structure of HA was established (14).

The name HA was proposed from the Greek *hyalos* (glassy, vitreous) and *uronic acid*. In 1984 it was renamed to HA.

### STRUCTURE OF HYALURONAN

By electron microscopy, HA is a linear polymer (15,16) composed of repeating alternating units of *N*-acetylglucosamine and glucuronic acid, all connected by  $\beta$ -linkages,  $\text{Glc}\alpha\beta(1\text{--}3)\text{GlcNAc}\beta(1\text{--}4)$ . Hyaluronan is the simplest of the glycosaminoglycans (GAGs), the only one neither covalently linked to a core protein nor synthesized by way of a Golgi pathway, and is the only nonsulfated GAG. Hyaluronan is thus the only GAG to date that is not also a component of a proteoglycan.

It has the anomalous ability of being both hydrophobic and hydrophilic, to associate with itself, with cell surface membranes, with proteins, or with other GAGs (17,18). The molecular domain of HA encompasses a large volume of water, and even at low concentrations, solutions have a very high viscosity. Dependent on pH, salt concentration, and associated cations, HA can take on a number of different shapes and configurations.

HA may reach a molecular mass of several millions. Although it has a simple chemical composition, HA has an extraordinarily high number of functions because of its molecular size. HA fragments constitute an information-rich system (19).

### BIOLOGY OF HYALURONAN

Hyaluronan acts as an organizer of the ECM, being the central molecule around which other components of the ECM orient themselves (20). Hyaluronan is generally produced in the interstitium, in the mesenchymal connective tissue of the body, being mainly a product of fibroblasts. HA is found at high concentrations in the dermis where it regulates water

balance, osmotic pressure, and functions as an ionic exchange resin. Hyaluronan plays a critical role in proliferation processes requiring cell movement and tissue organization (21,22). HA forms pericellular coats (2), and via its major cell-surface receptor CD44 as well as the intracellularly located receptor for HA-mediated motility (RHAMM) (23), it is able to initiate specific signaling events (3,31), promoting proliferation and migration of a variety of cell types including skin fibroblasts (24,25). Thus, HA is heavily involved in differentiation processes during wound healing and inflammation (21,22).

HA may be bound to proteins termed hyaladherins (26,27) in a very tight manner through electrostatic interactions. It may also be covalently bound to proteins that may function as a hyaluronidase inhibitor such as inter- $\alpha$ -trypsin inhibitor (28). The size of the HA polymer is critical for a number of its different biological functions. The extracellular large HA polymer is anti-inflammatory and anti-angiogenic, thus contributing to intact healthy tissues. HA fragments generated, for example, by enzymatic degradation or UV-radiation constitute an information-rich system (19). Low and intermediate MW HA fragments are highly angiogenic (29). They are usually signals for tissue injury and may modulate inflammatory responses via activating Toll-like receptors 2 and 4 (30,31).

85% of HA degradation products occur first in the lymphatic system; in the blood stream, it has a rapid turnover with a  $t_{1/2}$  of two to five minutes being removed by receptors in the liver and also, by unknown mechanisms, in the kidneys (32–34). Humans synthesize and degrade several grams of HA daily.

Hyaluronan supports and facilitates tumor progression. The quantity of HA surrounding tumor cells correlates with a poor prognosis in a number of malignancies (35), including malignant melanoma (36,37). HA is also a component of the group A streptococcal extracellular capsule (38) and is believed to play a role in virulence (39,40).

GAGs and proteoglycans must be distinguished from "mucins," the branch-chained sugars and their associated proteins. These occur more often on cell surfaces, though they also accumulate in the ECM, particularly in association with malignancies. The terms "mucin," "mucinous," "myxomatous," "myxoid," or "acid mucoproteins" may or may not, unless they have been defined biochemically, refer to HA-containing materials.

## SYNTHESIS

Hyaluronan is synthesized by members of the HA synthase family (HAS1, HAS2, and HAS3), three different isoforms that are located on the inner plasma membrane (41–43). The growing molecule is extruded via ABC-transporter (44) into the ECM under the influence of the HAS enzymes, permitting unconstrained polymer growth. The hyaluronan synthases produce different sizes of polysaccharide chains with average molecular weights of  $2 - 4 \times 10^6$  Da for HAS1 and HAS2, and  $0.4 - 2.5 \times 10^5$  Da for HAS3 (45,46).

Specific functions of the single members of the enzyme family have been only partly characterized. It is known that HAS1 and HAS2 produce high molecular weight HA that comprises, to a major extent, the three-dimensional structure of the ECM (47). HAS3 synthesizes HA of a lower molecular weight (48). Such low molecular weight HA has been shown to be more active during cell signaling (49–52). In case of low cell density, high HA synthesis correlates with a high proliferation rate and enhanced cell motility. Vice versa, high cell density corresponds with a low proliferation rate and low-level HA

synthesis. Several growth factors such as EGF, PDGF, TGF- $\beta$ 1, TGF- $\beta$ 2, Igf-I, FSH, cytokines such as IL-1, interferon- $\gamma$  are able to regulate HA synthesis via phosphorylation events (53–57). The various HA receptors also regulate synthesis of HA (58).

Glucocorticoids induce a nearly total inhibition of HAS messenger RNA (mRNA) in dermal fibroblasts. Extracts of dermal fibroblasts indicate that HAS2 is the predominant HAS in these cells. This may be the molecular basis of the decreased HA in glucocorticoid-treated skin. Levels of skin HA decrease after short-term glucocorticoid treatment because of a reduction in HA synthesis, whereas HA degradation is not changed (59).

## THE HYALURONIDASES

Hyaluronan is degraded through the hyaluronidase (HYAL) family of enzymes (60). In vertebrate tissues, total HA degradation occurs by the concerted effort of three separate enzymatic activities, hyaluronidases, and two exoglycosidases that remove the terminal sugars, a  $\beta$ -glucuronidase, and a  $\beta$ -N-acetyl glucosaminidase. Endolytic cleavage by the hyaluronidases generates ever-increasing numbers of substrates for the exoglycosidases. HYAL1 and HYAL2 are acid active enzymes that are located in the lysosomal compartment and glycosyl phosphatidylinositol-anchored in the plasma membrane, respectively. In a recent study, however, HYAL2 could not be detected in the plasma membrane but in a cellular localization, which might depend on the cell type (60–64).

HYAL1 generates tetrasaccharides, whereas HYAL2 produces HA fragments of  $10 - 20 \times 10^3$  Da (29,65). Both enzymes exist as soluble isoforms (61,65,66). HYAL3 is less characterized. It is still a matter of debate as to what extent HA is degraded by HYALs extracellularly and whether HA fragments are retained or released within the tissue (66,67). To date, such degradation products of HA have been rarely detected in vivo (68).

Especially in cases of tissue injury, in addition to the hyaluronidase catabolism also nonenzymatic degradation occurs by free radical-related depolymerization (29). This mechanism of depolymerization requires the presence of molecular oxygen, resulting in HA oligomers of different length (69–72). Such HA fragments of small and of intermediate size are highly pro-inflammatory (73).

## HYALURONIDASE INHIBITORS

Circulating hyaluronidase inhibitor activity has been identified in human serum over half a century ago (74,75). Modifications in levels of inhibitor activity have been observed in the serum of patients with cancer (76,77), patients with liver disease (78), and with certain dermatological disorders (79). Classes of lower molecular weight inhibitors of hyaluronidase have been identified; some of which are from plant origin such as flavonoids (80–82), aurothiomalate (83), hydrangenol (84), tannins (85), derivatives of tranilast (86), curcumin (87), and glycyrrhizin (88). Clinically, heparin, used as an anticoagulant, has potent anti-hyaluronidase activity (89), as does indomethacin (90,91), a classic nonsteroidal anti-inflammatory agent, and salicylates (92).

## HYALURONAN RECEPTORS

To date, three main groups of HA receptors have been identified: CD44, RHAMM (receptor for cell-mediated motility), and intracellular adhesion molecule 1 (ICAM1), with wide variations in locations, cell surface-associated, intracellular, both

cytoplasmic and nuclear. The most prominent is CD44, a transmembrane glycoprotein that occurs in a great variety of isoforms, products of a single gene with variant exon expression (93–96). Additional variations can occur as a result of post-translational glycosylation and addition of various GAG. CD44 is able to bind to a number of other ligands and has been shown to interact with fibronectin, collagen, and heparin-binding growth factors. Furthermore, CD44 plays a key role in cellular uptake of HA via internalization of the receptor with the attached HA. The complex is then catabolized in the lysosomes. CD44 has a high affinity to HA; other GAGs do barely compete with HA. However, small HA oligomers (deca-saccharide size) are able to “disconnect” the attached HA (97).

CD44 plays an important role in epidermal differentiation being a marker of growth and normal differentiation. The presence of CD44 marks the onset of keratinocyte stratification and mesenchymal maturation in fetal human skin (98), and the receptor function is calcium independent.

CD44 is distributed widely, being found virtually on all cells except red blood cells. It plays a role in cell adhesion, migration, lymphocyte activation and homing, and in cancer metastasis. The appearance of HA in dermis and epidermis parallels the histolocalization of CD44. The HA in the matrix surrounding keratinocytes serves as an adhesion substrate for Langerhans cells with their CD44-rich surfaces, as they migrate through the epidermis (99,100). In skin pathophysiology, the effect of local and systemic immune disorders on such interactions between Langerhans cells and keratinocytes awaits explication (101).

The other major receptor for HA is RHAMM (102,103), which is implicated in cell locomotion, focal adhesion turnover, and contact inhibition. It is also expressed in a number of variant isoforms. The interactions between HA and RHAMM regulate locomotion of cells by a complex network of signal transduction events and interaction with the cytoskeleton of the cells. It is also an important regulator of cell growth (104).

In fibroblasts, TGF- $\beta$  triggers the transcription, synthesis, and membrane expression not only of RHAMM but also the synthesis and expression of HA, all of which occurs coincidentally with the initiation of locomotion (8,105).

## HYALADHERINS

Hyaluronan also circulates in a free form in the lymphatic or cardiovascular system. However, even in this relatively free form, there are a number of binding proteins that decorate HA. These are referred to collectively as hyaladherins (26,27). The hyaladherins associate with HA through electrostatic bonds (28). It is likely that some of the unique properties attributed to HA are in fact a function of the hyaladherins that are bound to the HA. Growth factors, collagen (106), and a number of other proteins have been identified. One of the major challenges and opportunities in dermatology is to identify the profile of hyaladherins specific for the HA of dermis and epidermis, to characterize these proteins, and to understand their function in relation to age-related changes.

## HYALURONAN IN THE ECM

The ECM that surrounds cells and occupies the variable spaces between cells is composed predominantly of structural proteins such as collagen and elastin, as well as proteoglycans, and a number of glycoproteins. The basal lamina or basement mem-

brane that separates dermis and epidermis is composed of similar materials, and is therefore also considered an ECM structure. A number of growth factors are embedded in the ECM, concentrated by ECM components where they are protected from degradation. Such factors are presented to cells as mechanisms for growth control and modulators of cell function. Heparan sulfate-containing proteoglycans bind members of the FGF and EGF family (107), while HA can bind growth factors such as TGF- $\beta$  (108). An HA-rich environment is required for the maintenance of the undifferentiated, pluripotential state, facilitating motility and proliferation, while the heparan sulfate proteoglycans promote differentiation. However, the concentration of HA in the ECM can vary widely. Diameters of collagen fibers can be modulated by levels of HA, the thinner more delicate fibers being favored in regions of high HA concentrations. In fibroblast cultures, the addition of exogenous HA to the medium decreases the diameter of the collagen fibers that accumulate (unpublished observations).

## WOUND HEALING

In the earliest stages of wound healing, the ECM is very rich in HA, opening up intercellular spaces and creating a perfect environment for the high number of inflammatory cells to migrate into the temporary wound matrix. The initial granulation tissue formed is highly inflammatory with a high rate of tissue turnover mediated by matrix degrading enzymes and reactive oxygen metabolites produced by inflammatory cells. Low molecular weight fragments trigger the ongoing inflammation, thus playing a crucial role in organizing the granulation tissue. Hyaluronan may then also contribute to a major extend to stabilize granulation tissue by moderating inflammation, since it is able to function as a free radical scavenger (109). In the adult, HA levels rapidly reach a maximum and then drop rapidly (110). Decreasing HA levels are followed by increasing amounts of chondroitin sulfate, the appearance of fibroblasts, and then deposition of a collagen-rich ECM and wound healing results in scar formation (111). In the fetus, however, wound repair is associated with levels of HA that remain elevated, and the final result is a scar-free wound. Such observations were made in experimental fetal rabbit and sheep models as well as clinically in infants delivered following in utero surgery. It is on this basis that elevated HA in the wound matrix is assumed to be a key to decreased scarring, contractures, and adhesions in adult wound repair.

## HA DISTRIBUTION IN EPIDERMIS

Hyaluronan plays an important role in normal epidermis regarding barrier function, reepithelization processes, and wound healing. Especially in lower layers, where proliferating keratinocytes are found (112), HA plays a key role guaranteeing cell nutrition and removal of metabolic degradation products. High levels of HA are able to weaken desmosomal bindings and adhesive junctions of neighboring cells, which has a direct impact on metabolism and lifespan of epidermal cells. Thus, HA can directly influence growth and differentiation of keratinocytes, from the basal layer cells to the corneocyte.

The degree of hydration of the ECM and the activity of the immune system are also closely related. When the extracellular space enlarges, immunologically active cells such as Langerhans cells and lymphocytes can migrate faster through the epidermis (100).

Interaction of HA with receptors such as CD44 and RHAMM on and in keratinocytes can lead to a delay of differentiation or an accelerated cell growth. In this context, some authors suggest that topically applied HA may improve wound healing because it may provide an optimal environment for proliferating fibroblasts (113–115). HA turnover rate in epidermis and dermis is approximately 24 hours (116).

### AGING AND PHOTOAGING OF THE SKIN

Though dermal fibroblasts are mainly responsible for most skin HA, epidermal cells are also able to synthesize HA. In aging skin, HA disappears almost completely from the epidermis, whereas in the dermis, levels do not diminish but HA becomes increasingly associated with tissues and resistant to extraction *in vitro* (6). Such intercolated HA may have diminished ability to take on water of hydration resulting in loss of skin moisture. Progressive loss in the size of the HA polymer in skin as a function of age has also been reported (117).

The increased binding of HA with tissue as a function of age parallels the progressive cross-linking of collagen and the steady loss of collagen extractability with age. Each of these phenomena contributes to the apparent dehydration, atrophy, and loss of elasticity that characterize aged skin.

Ultraviolet radiation (UVR) plays a critical role in the process of photocarcinogenesis and environmentally induced aging, also known as photoaging or extrinsic aging (118,119). ROS are also generated intracellularly in the process of cellular energy production. Both extrinsic and intrinsic derived ROS are able to damage DNA, proteins, lipids, and ECM components such as HA. Repeated exposure to UV radiation causes premature aging of skin (120,121).

In a recent study, HA levels in both keratinocyte and fibroblast cultures were examined 3 and 24 hours after short-term UVB exposures. After 3 hours, HA levels were decreased in both cell type media, whereas 24 hours after irradiation, HA levels were increased in keratinocyte media but decreased in fibroblast media. These results were also supported by mRNA analyses of the respective enzymes. Hyaluronan synthase mRNA levels were increased in both cell types of cell cultures 24 hours after exposure, and HYAL levels are elevated only in fibroblast cultures. Interestingly, analysis of human dermal microdialysis fluid obtained *in vivo* did not contain inflammatory-sized HA fragments, but rather the products of further HA degradation (122).

Furthermore, UVB radiation leads to progressive down-regulation of all three HAS isoforms (123). However, in the same study, hyaluronidases (HYAL1 and HYAL2) and the HA receptor CD44 were not affected by UVB radiation. In murine skin, chronic repetitive UVB irradiation causes pronounced loss of HA from the upper dermis and loss of HA progresses even after cessation of UVB irradiation (123).

The skin, however, is well equipped with radical-scavenging systems, as, for example, enzymatic free radical scavengers such as superoxide dismutase and glutathione peroxidase or antioxidants such as ascorbic acid, tocopherols, or ubiquinone to name a few. Interestingly, HA itself is believed to act as a free radical scavenger (109). Unfortunately, in contrast to antioxidative vitamins or ubiquinone, no recycling system has been found as of today. Since scavenging of free radicals leads to HA degradation resulting in generation of low molecular weight fragments, this mechanism may contribute to inflammation and skin aging processes.

### COSMETIC APPLICATIONS

Because of its extraordinary capacities and functions regarding wound healing and skin moisturizing, HA became a favorite molecule of the cosmetic industry. A number of studies have shown that retinoic acid (vitamin A) and  $\alpha$ -hydroxy acids are able to increase HA content in skin, thus contributing to better tissue hydration (124,125). This may partly explain the antiaging properties of these substances. Hyaluronan is now a common ingredient in skin care products. Since HA solutions even at low concentration have a very high viscosity, topically applied HA provides a silky sensation on skin. Native high molecular weight HA remains on an intact skin barrier; thus it may contribute to a lower transepidermal water loss. Recently, it was shown that hyaluronan absorption into human skin was not restricted to small HA fragments as demonstrated by the recovery of polymers of a molecular size of 360 to 400 kDa from both blood and skin (126). In a different study, topical application of intermediate-size HA fragments on human aged and atrophic skin induced keratinocyte proliferation with restoration of normal skin thickness (127). Penetration of low molecular weight HA fragments through the stratum corneum and its potential side effects regarding its pro-inflammatory and angiogenic properties await further examination.

### HYALURONAN DERIVATIVES AS SKIN FILLERS

A number of HA derivatives have appeared for clinical application in dermatology that contain cross-linked HA polymers as well as HA-ester derivatives obtained by the conjugation of the carboxylic acid of HA with various drugs in their alcohol forms. The HA polymer because of its intrinsic biocompatibility, reactivity, and degradability will have many uses in the rapidly expanding field of tissue engineering, including skin augmentation.

Since 2003 HA is approved in the United States as an injectable filler for soft tissue augmentation by the FDA. In Europe, such preparations have been available since 1996 (128). Mainly because its rather short half-life in the dermis, HA has been chemically modified in many different ways to increase its longevity after being injected. An additional effect of these polymers appears to enhance local collagen production (129). Currently available are HA-based fillers of nonanimal source hyaluronic acid (NASHA), produced from bacteria by microbiologic engineering techniques, and also animal-derived HA products from rooster combs, which differ in particle size, degree of cross-linking, and concentration of HA (130). Intradermal injection of HA fillers is contraindicated in patients with autoimmune disorders, on immunosuppressive therapy, in patients with active herpetic or acneiform lesions. Additionally, potential allergies to animal protein have to be taken into account.

Since HA is present in almost every vertebrate tissue, the risk of immunogenicity to HA-derived products is considered to be low. Although HA-based fillers have in fact a low overall incidence of side effects, each of the filling materials can cause adverse outcomes ranging from acute hypersensitivity reactions to chronic lymphoplasmatic inflammatory reactions and foreign body-type granulomatous reactions that even may occur years after injection (130,131).

Small HA fragments are inducers of inflammation and angiogenesis, and are also important regulators of dendritic cells and macrophages (30). Generation of such small HA polymers resulting from enzymatic degradation or oxidative processes at the injection site may trigger acute and chronic

pro-inflammatory conditions, eventually leading to the adverse outcomes mentioned above.

Thus, in regard to current information, it is no longer possible to consider HA merely as an "inert filler."

## REFERENCES

- Toole BP. Proteoglycans and hyaluronan in morphogenesis and differentiation. In: Hay E, ed. *Cell Biology of Extracellular Matrix*. New York: Plenum Press, 1991:305–341.
- Toole BP. Hyaluronan promotes the malignant phenotype. *Glycobiology* 2002; 12(3):37R–42R.
- Turley EA, Noble PW, Bourguignon LY. Signaling properties of hyaluronan receptors. *J Biol Chem* 2002; 277(7):4589–4592.
- Entwistle J, Hall CL, Turley EA. HA receptors: regulators of signaling to the cytoskeleton. *J Cell Biochem* 1996; 61:569–577.
- Stern R. Hyaluronan catabolism: a new metabolic pathway. *Eur J Cell Biol* 2004; 83(7):317–325.
- Meyer LJ, Stern R. Age-dependent changes of hyaluronan in human skin. *J Invest Dermatol* 1994; 102:385–389.
- Vom Knorbelgewebe Henle F. *Allgemeine Anatomielehre, von dem Mischungs und Formbestandteilen des menschlichen Koerpers*. Leipzig: Leopold Voss Verlag, 1841:791–805.
- Duran-Reynals F. Exaltation de l'activité du virus vaccinal par les extraits de certains organs. *CR Soc Biol* 1928; 99:6–7.
- Duran-Reynals F, Suner Pi J. Exaltation de l'activité du Staphylocoque par les extraits testiculaires. *CR Soc Biol* 1929; 99:1908–1911.
- Duran-Reynals F. The effect of extracts of certain organs from normal and immunized animals on the infecting power of virus vaccine virus. *J Exp Med* 1929; 50:327–440.
- Duran-Reynals F, Stewart FW. The action of tumor extracts on the spread of experimental vaccinia of the rabbit. *Am J Cancer* 1933; 15:2790–2797.
- Duran-Reynals F. Studies on a certain spreading factor existing in bacteria and its significance for bacterial invasiveness. *J Exp Med* 1933; 58:161–181.
- Meyer K, Palmer JW. The polysaccharide of the vitreous humor. *J Biol Chem* 1934; 107:629–634.
- Rapport MM, Weissman B, Linker A, et al. Isolation of a crystalline disaccharide, hyalobiuronic acid, from hyaluronic acid. *Nature* 1951; 168:996–998.
- Cowman MK, Matsuoka S. Experimental approaches to hyaluronan structure. *Carbohydr Res* 2005; 340(5):791–809.
- Fraser JR, Laurent TC, Laurent UB. Hyaluronan: its nature, distribution, functions and turnover. *J Intern Med* 1997; 242(1):27–33.
- Knudson W. Tumor-associated hyaluronan. Providing an extracellular matrix that facilitates invasion. *Am J Pathol* 1996; 148:1721–1726.
- Toole BP, Wight TN, Tammi MI. Hyaluronan-cell interactions in cancer and vascular disease. *J Biol Chem* 2002; 277(7):4593–4596.
- Stern R, Asari AA, Sugahara KN. Hyaluronan fragments: an information-rich system. *Eur J Cell Biol* 2006; 85:699–715.
- Wight TN, Heinegaard DK, Hascall VC. Proteoglycan structure and function. In: Hay ED, ed. *Cell Biology of the Extracellular Matrix*. New York: Plenum Press, 1991:45.
- Laurent TC, Fraser JR. Hyaluronan. *FASEB J* 1992; 6:2397–2404.
- Laurent TC. *The Chemistry, Biology, and Medical Applications of Hyaluronan and Its Derivatives*. London: Portland Press, 1998:621.
- Hall CL, Turley EA. Hyaluronan: RHAMM mediated cell locomotion and signaling in tumorigenesis. *J Neurooncol* 1995; 26:221–229.
- Yoneda M, Yamagata M, Suzuki S, et al. Hyaluronic acid modulates proliferation of mouse dermal fibroblasts in culture. *J Cell Sci* 1988; 90(pt 2):265–273.
- Yoneda M, Shimizu S, Nishi Y, et al. Hyaluronic acid-dependent change in the extracellular matrix of mouse dermal fibroblasts that is conducive to cell proliferation. *J Cell Sci* 1988; 90 (pt 2):275–286.
- Toole BP. Hyaluronan and its binding proteins, the hyaladherins. *Curr Opin Cell Biol* 1990; 2:839–844.
- Knudson CB, Knudson W. Hyaluronan-binding proteins in development, tissue homeostasis, and disease. *FASEB J* 1993; 7:1233–1241.
- Zhao M, Yoneda M, Ohashi Y, et al. Evidence for the covalent binding of SHAP, heavy chains of inter-alpha-trypsin inhibitor, to hyaluronan. *J Biol Chem* 1995; 270:26657–26663.
- Noble PW. Hyaluronan and its catabolic products in tissue injury and repair. *Matrix Biol* 2002; 21(1):25–29.
- Termeer C, Benedix F, Sleeman J, et al. Oligosaccharides of hyaluronan activate dendritic cells via toll-like receptor 4. *J Exp Med* 2002; 195(1):99–111.
- Jiang D, Liang J, Fan J, et al. Regulation of lung injury and repair by Toll-like receptors and hyaluronan. *Nat Med* 2005; 11(11):1173–1179.
- Fraser JR, Laurent TC, Pertoft H, et al. Plasma clearance, tissue distribution and metabolism of hyaluronic acid injected intravenously in the rabbit. *Biochem J* 1981; 200:415–424.
- Reed RK, Laurent UB, Fraser JR, et al. Removal rate of [3H]-hyaluronan injected subcutaneously in rabbits. *Am J Physiol* 1990; 259(part 2):H532–H535.
- Laurent UB, Dahl LB, Reed RK. Catabolism of hyaluronan in rabbit skin takes place locally, in lymph nodes and liver. *Exp Physiol* 1991; 76:695–703.
- Boregowda RK, Appaiah HN, Siddaiah M, et al. Expression of hyaluronan in human tumor progression. *J Carcinog* 2006; 5:2.
- Ahrens T, Sleeman JP, Schempp CM, et al. Soluble CD44 inhibits melanoma tumor growth by blocking cell surface CD44 binding to hyaluronic acid. *Oncogene* 2001; 20(26):3399–3408.
- Ahrens T, Assmann V, Fieber C, et al. CD44 is the principal mediator of hyaluronic-acid-induced melanoma cell proliferation. *J Invest Dermatol* 2001; 116(1):93–101.
- Sugahara K, Schwartz NB, Dorfman A. Biosynthesis of hyaluronic acid by *Streptococcus*. *J Biol Chem* 1979; 254(14):6252–6261.
- Wessels MR, Moses AE, Goldberg JB, et al. Hyaluronic acid capsule is a virulence factor for mucoid group A streptococci. *Proc Natl Acad Sci U S A* 1991; 88(19):8317–8321.
- Schrager HM, Rheinwald JG, Wessels MR. Hyaluronic acid capsule and the role of streptococcal entry into keratinocytes in invasive skin infection. *J Clin Invest* 1996; 98(9):1954–1958.
- Itano N, Kimata K. Molecular cloning of human hyaluronan synthase. *Biochem Biophys Res Commun* 1996; 222:816–820.
- Spicer AP, Augustine ML, McDonald JA. Molecular cloning and characterization of a putative mouse hyaluronan synthase. *J Biol Chem* 1996; 271(38):23400–23406.
- Spicer AP, Olson JS, McDonald JA. Molecular cloning and characterization of a cDNA encoding the third putative mammalian hyaluronan synthase. *J Biol Chem* 1997; 272(14):8957–8961.
- Schulz T, Schumacher U, Prehm P. Hyaluronan export by the ABC transporter MRP5 and its modulation by intracellular cGMP. *J Biol Chem* 2007; 282(29):20999–21004.
- Weigel PH, Hascall VC, Tammi M. Hyaluronan synthases. *J Biol Chem* 1997; 272(22):13997–14000.
- Itano N, Kimata K. Mammalian hyaluronan synthases. *IUBMB Life* 2002; 54(4):195–199.
- Nishida Y, Knudson CB, Nietfeld JJ, et al. Antisense inhibition of hyaluronan synthase-2 in human articular chondrocytes inhibits proteoglycan retention and matrix assembly. *J Biol Chem* 1999; 274(31):21893–21899.
- Itano N, Sawai T, Yoshida M, et al. Three isoforms of mammalian hyaluronan synthases have distinct enzymatic properties. *J Biol Chem* 1999; 274(35):25085–25092.
- Camenisch TD, McDonald JA. Hyaluronan: is bigger better? *Am J Respir Cell Mol Biol* 2000; 23(4):431–433.
- Horton MR, McKee CM, Bao C, et al. Hyaluronan fragments synergize with interferon-gamma to induce the C-X-C chemokines mig and interferon-inducible protein-10 in mouse macrophages. *J Biol Chem* 1998; 273(52):35088–35094.

51. Lokeshwar VB, Selzer MG. Differences in hyaluronic acid-mediated functions and signaling in arterial, microvessel, and vein-derived human endothelial cells. *J Biol Chem* 2000; 275(36):27641–27649.
52. Ghatak S, Misra S, Toole BP. Hyaluronan oligosaccharides inhibit anchorage-independent growth of tumor cells by suppressing the phosphoinositide 3-kinase/Akt cell survival pathway. *J Biol Chem* 2002; 277(41):38013–38020.
53. Jacobson A, Brinck J, Briskin MJ, et al. Expression of human hyaluronan synthases in response to external stimuli. *Biochem J* 2000; 348(pt 1):29–35.
54. Tirone E, D'Alessandris C, Hascall VC, et al. Hyaluronan synthesis by mouse cumulus cells is regulated by interactions between follicle-stimulating hormone (or epidermal growth factor) and a soluble oocyte factor (or transforming growth factor beta1). *J Biol Chem* 1997; 272(8):4787–4794.
55. Tzanakakis GN, Karamanos NK, Hjerpe A. Effects on glycosaminoglycan synthesis in cultured human mesothelioma cells of transforming, epidermal, and fibroblast growth factors and their combinations with platelet-derived growth factor. *Exp Cell Res* 1995; 220(1):130–137.
56. Sugiyama Y, Shimada A, Sayo T, et al. Putative hyaluronan synthase mRNA are expressed in mouse skin and TGF-beta upregulates their expression in cultured human skin cells. *J Invest Dermatol* 1998; 110(2):116–121.
57. Syrokou A, Tzanakakis G, Tsegenidis T, et al. Effects of glycosaminoglycans on proliferation of epithelial and fibroblast human malignant mesothelioma cells: a structure-function relationship. *Cell Prolif* 1999; 32(2–3):85–99.
58. Cichy J, Puré E. Cytokines regulate the affinity of soluble CD44 for hyaluronan. *FEBS Lett* 2004; 556(1–3):69–74.
59. Gebhardt C, Averbek M, Diedenhofen N, et al. Dermal hyaluronan is rapidly reduced by topical treatment with glucocorticoids. *J Invest Dermatol* 2010; 130(1):141–149.
60. Csoka AB, Frost GI, Stern R. The six hyaluronidase-like genes in the human and mouse genomes. *Matrix Biol* 2001; 20:499–508.
61. Kreil G. Hyaluronidases—a group of neglected enzymes. *Protein Sci* 1995; 4:1666–1669.
62. Frost GI, Csoka AB, Wong T, et al. Purification, cloning, and expression of human plasma hyaluronidase. *Biochem Biophys Res Commun* 1997; 236(1):10–15.
63. Strobl B, Wechselberger C, Beier DR, et al. Structural organization and chromosomal localization of Hyal2, a gene encoding a lysosomal hyaluronidase. *Genomics* 1998; 53(2):214–219.
64. Chow G, Knudson CB, Knudson W. Expression and cellular localization of human hyaluronidase-2 in articular chondrocytes and cultured cell lines. *Osteoarthritis Cartilage* 2006; 14(9):849–858.
65. Lepperdinger G, Müllegger J, Kreil G. Hyal2—less active, but more versatile? *Matrix Biol* 2001; 20(8):509–514.
66. Stern R. Devising a pathway for hyaluronan catabolism: are we there yet? *Glycobiology* 2003; 13(12):105R–115R.
67. Knudson W, Chow G, Knudson CB. CD44-mediated uptake and degradation of hyaluronan. *Matrix Biol* 2002; 21(1):15–23.
68. McKee CM, Lowenstein CJ, Horton MR, et al. Hyaluronan fragments induce nitric-oxide synthase in murine macrophages through a nuclear factor kappaB-dependent mechanism. *J Biol Chem* 1997; 272(12):8013–8018.
69. Uchiyama H, Dobashi Y, Ohkouchi K, et al. Chemical change involved in the oxidative reductive depolymerization of hyaluronic acid. *J Biol Chem* 1990; 265:7753–7759.
70. Agren UM, Tammi RH, Tammi MI. Reactive oxygen species contribute to epidermal hyaluronan catabolism in human skin organ culture. *Free Radic Biol Med* 1997; 23(7):996–1001.
71. Deguine V, Menasche M, Ferrari P, et al. Free radical depolymerization of hyaluronan by Maillard reaction products: role in liquefaction of aging vitreous. *Int J Biol Macromol* 1998; 22(1):17–22.
72. Hawkins CL, Davies MJ. Degradation of hyaluronic acid, poly- and monosaccharides, and model compounds by hypochlorite: evidence for radical intermediates and fragmentation. *Free Radic Biol Med* 1998; 24(9):1396–1410.
73. Termeer C, Sleeman JP, Simon JC. Hyaluronan—magic glue for the regulation of the immune response? *Trends Immunol* 2003; 24(3):112–114.
74. Haas E. On the mechanism of invasion. I. Antivasin I, an enzyme in plasma. *J Biol Chem* 1946; 163:63–68.
75. Dorfman A, Ott ML, Whitney R. The hyaluronidase inhibitor of human blood. *J Biol Chem* 1948; 223:621–629.
76. Fiszer-Szfarz B. Demonstration of a new hyaluronidase inhibitor in serum of cancer patients. *Proc Soc Exp Biol Med* 1968; 128:300–302.
77. Kolarova M. Host-tumor relationship XXXIII. Inhibitor of hyaluronidase in blood serum of cancer patients. *Neoplasma* 1975; 22:435–439.
78. Snively GG, Glick D. Mucolytic enzyme systems. X. Serum hyaluronidase inhibitor in liver disease. *J Clin Invest* 1950; 29:1087–1090.
79. Grais ML, Glick D. Mucolytic enzyme systems. X. Serum hyaluronidase inhibitor in liver disease. *J Clin Inv* 1950; 29:1087–1092.
80. Kuppusamy UR, Khoo HE, Das NP. Structure-activity studies of flavonoids as inhibitors of hyaluronidase. *Biochem Pharmacol* 1990; 40:397–401.
81. Kuppusamy UR, Das NP. Inhibitory effects of flavonoids on several venom hyaluronidases. *Experientia* 1991; 47:1196–1200.
82. Li MW, Yudin AI, VandeVoort CA, et al. Inhibition of monkey sperm hyaluronidase activity and heterologous cumulus penetration by flavonoids. *Biol Reprod* 1997; 56:1383–1389.
83. Perreault S, Zaneveld LJ, Rogers BJ. Inhibition of fertilization in the hamster by sodium aurothiomalate, a hyaluronidase inhibitor. *J Reprod Fertil* 1980; 60:461–467.
84. Kakegawa H, Matsumoto H, Satoh T. Inhibitory effects of hydrangenol derivatives on the activation of hyaluronidase and their antiallergic activities. *Planta Med* 1988; 54:385–389.
85. Kakegawa H, Matsumoto H, Endo K, et al. Inhibitory effects of tannins on hyaluronidase activation and on the degranulation from rat mesenteric mast cells. *Chem Pharm Bull (Tokyo)* 1985; 33:5079–5082.
86. Kakegawa H, Mitsuo N, Matsumoto H, et al. Hyaluronidase-inhibitory and anti-allergic activities of the photo-irradiated products of tranilast. *Chem Pharm Bull (Tokyo)* 1985; 33:3738–3744.
87. Tonnesen HH. Studies of curcumin and curcuminoids. XIV. Effect of curcumin on hyaluronic acid degradation in vitro. *Int J Pharm* 1989; 50:91–94.
88. Furuya T, Yamagata S, Shimoyama Y, et al. Biochemical characterization of glycyrrhizin as an effective inhibitor for hyaluronidases from bovine testis. *Biol Pharm Bull* 1997; 20:973–977.
89. Wolf RA, Glogar D, Chaung LY, et al. Heparin inhibits bovine testicular hyaluronidase activity in myocardium of dogs with coronary artery occlusion. *Am J Cardiol* 1984; 53:941–944.
90. Szary A, Kowalczyk-Bronisz SH, Gioldanowski J. Indomethacin as inhibitor of hyaluronidase. *Arch Immunol Ther Exp (Warsz)* 1975; 23:131–134.
91. Kushwah A, Amma MK, Sareen KN. Effect of some antiinflammatory agents on lysosomal and testicular hyaluronidases. *Indian J Exp Biol* 1978; 16:222–224.
92. Guerra F. Hyaluronidase inhibition by sodium salicylate in rheumatic fever. *Science* 1946; 103:686–687.
93. Underhill C. CD44: the hyaluronan receptor. *J Cell Sci* 1992; 103(pt 2):293–298.
94. Lesley J, Hymen R. CD44 structure and function. *Front Biosci* 1998; 3:616–630.
95. Naor D, Sionov RV, Ish-Shalom D. CD44: structure, function, and association with the malignant process. *Adv Cancer Res* 1997; 71:241–319.
96. Aruffo A, Stamenkovic I, Melnick M, et al. CD44 is the principal cell surface receptor for hyaluronate. *Cell* 1990; 61(7):1303–1313.
97. Tammi R, MacCallum D, Hascall VC, et al. Hyaluronan bound to CD44 on keratinocytes is displaced by hyaluronan decasaccharides and not hexasaccharides. *J Biol Chem* 1998; 273(44):28878–28888.



98. Tuhkanen AL, Agren UM, Tammi MI, et al. CD44 expression marks the onset of keratinocyte stratification and mesenchymal maturation into fibrous dermis in fetal human skin. *J Histochem Cytochem* 1999; 47(12):1617-1624.
99. Weiss JM, Sleeman J, Renkl AC, et al. An essential role for CD44 variant isoforms in epidermal Langerhans cell and blood dendritic cell function. *J Cell Biol* 1997; 137:1137-1147.
100. Weiss JM, Renkl AC, Sleeman J, et al. CD44 variant isoforms are essential for the function of epidermal Langerhans cells and dendritic cells. *Cell Adhes Commun* 1998; 6:157-160.
101. Seiter S, Schadendorf D, Tilgen W, et al. CD44 variant isoform expression in a variety of skin-associated autoimmune diseases. *Clin Immunol Immunopathol* 1998; 89:79-93.
102. Turley EA. Hyaluronan and cell locomotion. *Cancer Metastasis Rev* 1992; 11:21-30.
103. Turley EA, Harrison R. RHAMM, a member of the hyaladherins. Available at: <http://www.glycoforum.gr.jp>, 1999.
104. Mohapatra S, Yang X, Wright JA, et al. Soluble hyaluronan receptor RHAMM induces mitotic arrest by suppressing Cdc2 and cyclin B1 expression. *J Exp Med* 1996; 183:1663-1668.
105. Samuel SK, Hurta RA, Spearman MA, et al. TGF-beta 1 stimulation of cell locomotion utilizes the hyaluronan receptor RHAMM and hyaluronan. *J Cell Biol* 1993; 123:749-758.
106. Gross RL, Latty A, Williams EA, et al. Abnormal spontaneous rosette formation and rosette inhibition in lung carcinoma. *N Engl J Med* 1975; 292:169-181.
107. Piepkorn M, Pittelkow MR, Cook PW. Autocrine regulation of keratinocytes: the emerging role of heparin-binding, epidermal growth factor-related growth factors. *J Invest Dermatol* 1998; 111:715-721.
108. Locci P, Marinucci L, Lilli C, et al. Transforming growth factor beta 1-hyaluronic acid interaction. *Cell Tissue Res* 1995; 281:317-324.
109. Foschi D, Castoldi L, Radaelli E, et al. Hyaluronic acid prevents oxygen free-radical damage to granulation tissue: a study in rats. *Int J Tissue React* 1990; 12(6):333-339.
110. Longaker MT, Chiu ES, Adzick NS, et al. Studies in fetal wound healing. V. A prolonged presence of hyaluronic acid characterizes fetal wound fluid. *Ann Surg* 1991; 213:292-296.
111. Chen WY, Abatangelo G. Functions of hyaluronan in wound repair. *Wound Repair Regen* 1999; 7(2):79-89.
112. Tammi R, Ripellino JA, Margolis RU, et al. Hyaluronate accumulation in human epidermis treated with retinoic acid in skin organ culture. *J Invest Dermatol* 1989; 92(3):326-332.
113. Slevin M, Krupinski J, Gaffney J, et al. Hyaluronan-mediated angiogenesis in vascular disease: uncovering RHAMM and CD44 receptor signaling pathways. *Matrix Biol* 2007; 26(1):58-68.
114. Tolg C, Hamilton SR, Nakrieko KA, et al. Rhamm-/- fibroblasts are defective in CD44-mediated ERK1,2 mitogenic signaling, leading to defective skin wound repair. *J Cell Biol* 2006; 175(6):1017-1028.
115. Gao F, Yang CX, Mo W, et al. Hyaluronan oligosaccharides are potential stimulators to angiogenesis via RHAMM mediated signal pathway in wound healing. *Clin Invest Med* 2008; 31(3): E106-E116.
116. Reed RK, Lilja K, Laurent TC. Hyaluronan in the rat with special reference to the skin. *Acta Physiol Scand* 1988; 134:405-411.
117. Longas MO, Russell CS, He XY. Evidence for structural changes in dermatan sulfate and hyaluronic acid with aging. *Carbohydr Res* 1987; 159:127-136.
118. Berneburg M, Krutmann J. Photoimmunology, DNA repair and photocarcinogenesis. *J Photochem Photobiol B* 2000; 54(2-3): 87-93.
119. Gilchrist BA, Park HY, Eller MS, et al. Mechanisms of ultraviolet light-induced pigmentation. *Photochem Photobiol* 1996; 63(1):1-10.
120. Gilchrist BA. A review of skin ageing and its medical therapy. *Br J Dermatol* 1996; 135:867-875.
121. Bernstein EF, Underhill CB, Hahn PJ, et al. Chronic sun exposure alters both the content and distribution of dermal glycosaminoglycans. *Br J Dermatol* 1996; 135:255-262.
122. Averbek M, Gebhardt CA, Voigt S, et al. Differential regulation of hyaluronan metabolism in the epidermal and dermal compartments of human skin by UVB irradiation. *J Invest Dermatol* 2007; 127(3):687-697.
123. Dai G, Freudenberger T, Zipper P, et al. Chronic ultraviolet B irradiation causes loss of hyaluronic acid from mouse dermis because of down-regulation of hyaluronic acid synthases. *Am J Pathol* 2007; 171(5):1451-1461.
124. Pasonen-Seppänen SM, Maytin EV, Törrönen KJ, et al. All-trans retinoic acid-induced hyaluronan production and hyperplasia are partly mediated by EGFR signaling in epidermal keratinocytes. *J Invest Dermatol* 2008; 128(4):797-807.
125. Bernstein EF, Lee J, Brown DB, et al. Glycolic acid treatment increases type I collagen mRNA and hyaluronic acid content of human skin. *Dermatol Surg* 2001; 27(5):429-433.
126. Brown TJ, Alcorn D, Fraser JR. Absorption of hyaluronan applied to the surface of intact skin. *J Invest Dermatol* 1999; 113(5): 740-746.
127. Kaya G, Tran C, Sorg O, et al. Hyaluronate fragments reverse skin atrophy by a CD44-dependent mechanism. *PLoS Med* 2006; 3(12):e493.
128. Andre P. Hyaluronic acid and its use as a "rejuvenation" agent in cosmetic dermatology. *Semin Cutan Med Surg* 2004; 23(4):218-222.
129. Wang F, Garza LA, Kang S, et al. In vivo stimulation of de novo collagen production caused by cross-linked hyaluronic acid dermal filler injections in photodamaged human skin. *Arch Dermatol* 2007; 143(2):155-163.
130. Edwards PC, Fantasia JE. Review of long-term adverse effects associated with the use of chemically-modified animal and non-animal source hyaluronic acid dermal fillers. *Clin Interv Aging* 2007; 2(4):509-519.
131. Andre P, Lowe NJ, Parc A, et al. Adverse reactions to dermal fillers: a review of European experiences. *J Cosmet Laser Ther* 2005; 7(3-4):171-176.

# Organic acids with novel functions, $\alpha$ -hydroxy, aldobionic, *N*-acetylamino acids, and related compounds

Ruey J. Yu and Eugene J. Van Scott

## INTRODUCTION

Organic acids cover a wide range of organic compounds having an acidic group such as carboxyl, sulfonyl or phosphoryl, which include retinoic acid, salicylic acid, benzoic acid and its peroxide form, benzoyl peroxide. The present discussion will focus on certain organic carboxylic acids and related derivatives with unique cosmetic and dermatological effects on the skin. These acids are  $\alpha$ -hydroxy acids (AHAs),  $\beta$ -hydroxyacids (BHAs), polyhydroxy acids (PHAs), aldobionic acids (ABAs), *N*-acetylamino acids (NAAs), and *N*-(phosphonomethyl)amino acids (NPAs).

Hydroxyacids and related acids of nonphenolic origin are a group of natural and physiological substances which have profound effects on keratinization and the synthesis of dermal components. Many hydroxyacids and related acids occur in food, fruits such as sugar cane, tomato, oranges, lemons, grapes, apples, mangos and body tissues. For many years, cosmetic chemists have used lactic acid, along with other organic acids to adjust pH; and citric acid as a chelating and antioxidant stabilizer in topical formulations. In addition, lactic acid has been used as a stabilizer in urea formulations for topical treatment of dry skin.

In 1974 the term AHAs was first introduced to dermatology when it was reported that AHAs substantially improved the severe hyperkeratotic conditions of ichthyosis (1). AHAs are also beneficial for topical treatment of dry skin, dandruff, calluses, acne, keratoses, warts, wrinkles, photoaging skin, and for other cosmetic conditions and dermatological purposes (2–5). AHAs such as glycolic acid and lactic acid are routinely used in peel solutions by estheticians and dermatologists. In dermatological office procedures they are used for topical management and treatment of various skin conditions including skin smoothing, acne and skin changes associated with intrinsic and extrinsic aging (6–9). AHAs on topical application have been shown to markedly increase biosynthesis of hyaluronic acid in the papillary dermis, although the mechanism of action is unknown (5,10).

Polyhydroxy AHAs constitute one of the two major components of hyaluronic acid, chondroitin sulfate, dermatan sulfate, heparin and heparan sulfate. In combination with numerous cosmetic or pharmaceutical agents, hydroxyacids have been found to enhance desirable topical effects, and also to reduce or prevent side-effects caused by topical agents. Because most hydroxyacids are nontoxic, natural and physiological they are used as primary or secondary ingredients in many cosmetic and pharmaceutical products.

NAAs and NPAs are both derived from amino acids by substitution at the amino group. *N*-Acetyl-L-cysteine (NAC) has been shown to be a potent antioxidant. We have found

*N*-acetyl-L-proline and *N*-acetyl-L-glutamine to be topically effective for relieving itch associated with eczema and xerosis. We have also found *N*-(phosphonomethyl)glycine, a commercial herbicide ingredient, to be topically effective for ichthyosis.

In this chapter we discuss the scientific basis for topical effects of certain organic acids in dermatological therapy and in various cosmetic applications.

## HYDROXYACIDS: NOMENCLATURE AND OCCURRENCE

Organic hydroxyacids of nonphenolic origin may be classified into the following four groups: AHAs; BHAs; PHAs; and ABAs. Regarding group names, the spellings  $\alpha$ -hydroxyacid and  $\beta$ -hydroxyacid are preferred instead of  $\alpha$ -hydroxy acid and  $\beta$ -hydroxy acid because  $\alpha$  and  $\beta$  indicate the position of hydroxyl group in the hydroxyacid molecule. In contrast, the spelling polyhydroxy acid is preferred instead of poly-hydroxyacid or poly-hydroxy acid because in the word, poly indicates many or multiple hydroxyl groups, not the position of hydroxyl group in the acid (11).

## $\alpha$ -HYDROXYACIDS

AHAs are organic carboxylic acids having one hydroxyl group attached directly to  $\alpha$  position of an aliphatic or alicyclic carbon atom, but not to a benzene or other aromatic ring. On a broader scope, AHAs may include those having additional carboxyl groups (11). Glycolic acid, present in sugar cane juice, is the smallest molecule of all the hydroxyacids, and is a major ingredient in most AHA products on the market. All other AHAs may be considered derivatives or substituted glycolic acid. The AHAs may be divided into three subgroups: alkyl AHAs; aralkyl AHAs; and polycarboxyl AHAs.

### Alkyl AHAs

A radical attached to  $\alpha$  carbon of glycolic acid can be a simple hydrocarbon called alkyl group. The smallest alkyl group is a methyl group and in this case, the AHA is lactic acid (present in tomatoes). Representative alkyl AHAs are listed in Table 10.1.

### Aralkyl AHAs

Aralkyl is an abbreviation of aryl plus alkyl. Aralkyl AHA is formed when a phenyl group is attached to an alkyl AHA, and is represented by mandelic acid, benzilic acid, 3-phenyllactic acid and atrolactic acid. Mandelic acid has been used in combination as methenamine mandelate for oral administration to treat urinary tract infections.

**Table 10.1** Nomenclature and Occurrence of Glycolic Acid and Alkyl  $\alpha$ -Hydroxyacids

Systematic name and chemical structure	Common name	Occurrence
2-Hydroxyethanoic acid CH <sub>2</sub> OHCOOH	Glycolic acid Hydroxyacetic acid	Sugarcane
2-Hydroxypropanoic acid CH <sub>3</sub> CHOHCOOH	Lactic acid	Tomato
2-Methyl-2-hydroxypropanoic acid (CH <sub>3</sub> ) <sub>2</sub> COHCOOH	Methylactic acid	Mango
2-Hydroxybutanoic acid CH <sub>3</sub> CH <sub>2</sub> CHOHCOOH	$\alpha$ -Hydroxybutyric acid	
2-Hydroxyoctanoic acid CH <sub>3</sub> (CH <sub>2</sub> ) <sub>5</sub> CHOHCOOH	$\alpha$ -Hydroxycaprylic acid	
2-Hydroxyeicosanoic acid CH <sub>3</sub> (CH <sub>2</sub> ) <sub>17</sub> CHOHCOOH	$\alpha$ -Hydroxyarachidonic acid	
2-Hydroxytetraeicosanoic acid CH <sub>3</sub> (CH <sub>2</sub> ) <sub>21</sub> CHOHCOOH	Cerebronic acid	Skin as ceramide

**Table 10.2** Nomenclature and Occurrence of Polycarboxy  $\alpha$ -Hydroxyacids

Systematic name and chemical structure	Common name	Occurrence
2-Hydroxypropane-1,3-dioic acid HOOC CHOH COOH	Tartronic acid	
2-Hydroxybutane-1,4-dioic acid HOOC CH <sub>2</sub> CHOH COOH	Malic acid	Apple
2-Methyl-2-hydroxybutane-1,4-dioic acid HOOC CH <sub>2</sub> C(CH <sub>3</sub> )OH COOH	Citramalic acid	
2,3-Dihydroxybutane-1,4-dioic acid HOOC CHOH CHOH COOH	Tartaric acid	Grape
3-Carboxy-3-hydroxypentane-1,5-dioic acid C(OH)(COOH) (CH <sub>2</sub> COOH) <sub>2</sub>	Citric acid	Orange Lemon
3-Carboxy-2-hydroxypentane-1,5-dioic acid HOOCCHOH CH(COOH) CH <sub>2</sub> COOH	Isocitric acid	
3-Carboxy-3-hydroxyhexane-1,6-dioic acid HOOCCH <sub>2</sub> C(OH)(COOH) CH <sub>2</sub> CH <sub>2</sub> COOH	Homocitric acid	
3-Carboxy-2-hydroxyhexane-1,6-dioic acid HOOCCHOH CH(COOH) CH <sub>2</sub> CH <sub>2</sub> COOH	Homoisocitric acid	
3-Carboxy-2- <i>n</i> -hexadecyl-3-hydroxypentane 1,5-Dioic acid HOOCCH <sub>2</sub> C(OH)(COOH) CH(C <sub>16</sub> H <sub>33</sub> )COOH	Agaric acid <i>n</i> -Hexadecyl citric acid	

### Polycarboxy AHAs

AHA may consist of more than one carboxyl group as shown in Table 10.2. Malic acid, occurring in apples, is also called apple acid, and tartaric acid, present in grapes, has been called fruit acid in the past. Citric acid, occurring in oranges and lemons, has one hydroxyl group and three carboxyl groups. The AHA or BHA refers to the position of a hydroxyl group as related to a carboxyl group in the hydroxyacid. When a hydroxyacid has more than one carboxyl group it can be an AHA and BHA at the same time. For example, malic acid, tartaric acid and citric acid can be both AHA and BHA.

### $\beta$ -HYDROXYACIDS

BHAs are organic carboxylic acids having one hydroxyl group attached to a carbon atom at the  $\beta$  position, and are represented by  $\beta$ -hydroxybutanoic acid and tropic acid.  $\beta$ -Hydroxybutanoic acid, also known as  $\beta$ -hydroxybutyric acid, is excreted as much as 30 g/day in the urine of diabetic subjects. Salicylic acid, 2-hydroxybenzoic acid, has both hydroxyl and carboxyl

groups directly attached to a benzene ring. It is not chemically a true BHA, but it is erroneously referred to as a BHA (12) in casual jargon.

### POLYHYDROXY ACIDS

PHAs are organic carboxylic acids having multiple hydroxyl groups (13). Many PHAs are also AHAs; they are derived from carbohydrates, and are important intermediates in carbohydrate metabolism. PHAs may be divided into three groups: aldonic acid, aldaric acid, and alduronic acid.

### Aldonic Acid

An aldonic acid is a carbohydrate, called aldose, having the carbon atom at position one oxidized to a carboxyl group and is represented by ribonic acid and gluconic acid, as shown in Table 10.3. Vitamin C, L-ascorbic acid, is a 1,4-lactone form of the AHA 2,4,5,6-tetrahydroxy-3-ketohexanoic acid, a keto PHA with chemical structure: HOCH<sub>2</sub> CHOH CHOH CO CHOH COOH. The lactone form of vitamin C has two acidic

**Table 10.3** Nomenclature and Occurrence of Aldonic Acids

Systematic name and chemical structure	Common name Stereoisomer name	Occurrence
2,3-Dihydroxypropanoic acid HOCH <sub>2</sub> CHOH COOH	Glyceric acid	
3,3-Dimethyl-2,4-dihydroxybutanoic acid HOCH <sub>2</sub> C(CH <sub>3</sub> ) <sub>2</sub> CHOH COOH	Pantoic acid	In vitamin B <sub>5</sub>
2,3,4-Trihydroxybutanoic acid HOCH <sub>2</sub> (CHOH) <sub>2</sub> COOH	Erythronic acid Threonic acid	
2,3,4,5-Tetrahydroxypentanoic acid HOCH <sub>2</sub> (CHOH) <sub>3</sub> COOH	Ribonic acid, arabinoic acid, xylonic acid, lyxonic acid	
2,3,4,5,6-Pentahydroxyhexanoic acid HOCH <sub>2</sub> (CHOH) <sub>4</sub> COOH	Allonic acid, altronic acid, gluconic acid, mannoic acid, gulonic acid, idonic acid, galactonic acid, talonic acid	In skin
2,3,4,5,6,7-Hexahydroxyheptanoic acid HOCH <sub>2</sub> (CHOH) <sub>5</sub> COOH	Alloheptonic acid, althroheptonic acid, glucoheptonic acid, mannoheptonic acid, guloheptonic acid, idoheptonic acid, galactoheptonic acid, taloheptonic acid	

hydroxyl groups at carbon positions 2 and 3, and does not have an effect on keratinization comparable to that of  $\alpha$ -hydroxy PHAs.

### Aldaric Acid

An aldaric acid is a carbohydrate having two carbon atoms at the end positions oxidized to carboxyl groups, and is represented by glucaric acid (saccharic acid) and galactaric acid (mucic acid).

### Alduronic Acid

An alduronic acid is a carbohydrate having the terminal carbon oxidized to a carboxyl group, and is represented by glucuronic acid which is produced in the body as a detoxifying agent, and forms hyaluronic acid with *N*-acetyl glucosamine.

### ALDOBIONIC ACIDS

ABA, also known as bionic acid, consists of one monosaccharide chemically linked through an ether bond to an aldonic acid as shown in Table 10.4. An ABA may also be described as an oxidized form of a disaccharide or dimeric carbohydrate, such

as lactobionic acid derived from lactose and maltobionic acid from maltose. Lactobionic acid solution is currently used in preservative media for organ transplants.

### AHA-RELATED COMPOUNDS

An  $\alpha$ -ketoacid has a keto instead of hydroxyl group at the  $\alpha$  carbon of an organic carboxylic acid, and is related to its counterpart AHA. Pyruvic acid (2-ketopropanoic acid, CH<sub>3</sub> CO COOH) and lactic acid have such a biochemical relationship in that the latter can be converted to the former when the hydroxyl group is oxidized to keto group by lactate dehydrogenase.

### HYDROXYACIDS: PHYSICO-CHEMICAL PROPERTIES Stereoisomers

Stereoisomers are formed when a carbon in a hydroxyacid has a stereocenter in the molecule, that is, the carbon has four nonidentical radicals. Whereas glycolic acid, methylactic acid and benzilic acid do not have stereoisomers, lactic acid and mandelic acid have stereoisomers, D and L forms. Tartronic

**Table 10.4** Nomenclature and Source of Aldobionic Acids

Common name	Chemical structure	Source
Lactobionic acid	HOH <sub>2</sub> C CHOH CHOR(CHOH) <sub>2</sub> COOH R, galactose; 4- <i>O</i> - $\beta$ -D-Gal-D-gluconic acid	Lactose
Isolactobionic acid	6- <i>O</i> - $\beta$ -D-Gal-D-gluconic acid	Isolactose
Maltobionic acid	HOH <sub>2</sub> C CHOH CHOR(CHOH) <sub>2</sub> COOH R, glucose; 4- <i>O</i> - $\alpha$ -D-Glc-D-gluconic acid	Maltose
Isomaltobionic acid	6- <i>O</i> - $\alpha$ -D-Glc-D-gluconic acid	Isomaltose
Cellobionic acid	HOH <sub>2</sub> C CHOH CHOR(CHOH) <sub>2</sub> COOH R, glucose; 4- <i>O</i> - $\beta$ -D-Glc-D-gluconic acid	Cellobiose
Gentiobionic acid	ROH <sub>2</sub> C (CHOH) <sub>4</sub> COOH R, glucose; 6- <i>O</i> - $\beta$ -D-Glc-D-gluconic acid	Gentiobiose
Kojibionic acid	HOH <sub>2</sub> C (CHOH) <sub>3</sub> CHORCOOH R, glucose; 2- <i>O</i> - $\alpha$ -D-Glc-D-gluconic acid	Kojibiose
Laminarabionic acid	HOH <sub>2</sub> C (CHOH) <sub>2</sub> CHORCHOHCOOH R, glucose; 3- <i>O</i> - $\beta$ -D-Glc-D-gluconic acid	Laminarabiose
Melibionic acid	ROH <sub>2</sub> C (CHOH) <sub>4</sub> COOH R, galactose; 6- <i>O</i> - $\alpha$ -D-Gal-D-gluconic acid	Melibiose
Nigerobionic acid	3- <i>O</i> - $\alpha$ -D-Glc-D-gluconic acid	Nigerose
Sophorobionic acid	2- <i>O</i> - $\beta$ -D-Glc-D-gluconic acid	Sophorose

acid and citric acid do not have stereoisomers, but malic acid has D and L, and tartaric acid has D, L, and meso forms. For PHAs and ABAs, stereoisomers usually result in different chemical names, such as ribonic acid and arabinoic acid; gluconic acid and galatonic acid; lactobionic acid and maltobionic acid, and often retain similar though not identical functions.

### Lactone Form

In contrast to AHAs and BHAs, many PHAs can form spontaneous intramolecular lactones by elimination of water molecule between the carboxyl and hydroxyl groups, especially when these two functional groups are separated by three or four carbons. D-Gluconolactone, known as D-gluconic acid  $\delta$ -lactone, is formed by eliminating one mole of water between the carboxyl group and the hydroxyl group at carbon 5 position of D-gluconic acid, forming a six-member ring lactone.

### Solubility and Gel Matrix

AHAs and BHAs with small molecular weight, and most PHAs and ABAs are soluble in water. Certain AHAs and BHAs are also soluble in alcohol such as methylactic acid, mandelic acid, malic acid, phenyllactic acid, atrolactic acid and tropic acid. Some aralkyl AHAs are lipophilic, and are more soluble in alcohol than water, such as benzilic acid.

One unique property of ABAs is their potential to form a gel matrix with water. Maltobionic acid can form a clear gel matrix containing 29% water molecules complexed with maltobionic molecules. Under the same conditions, lactobionic acid and cellobionic acid can form clear gels containing 14% and 7% water, respectively. The gel matrix may add protective, soothing and healing effects for inflamed skin or in wound healing.

### Acid Strength and $pK_a$

The acid strength of an organic hydroxyacid is determined by its proton dissociation from the carboxyl group in aqueous solution. After equilibrium is reached, the dissociation constant  $K_a$  is defined as hydroxyacid anion multiplied by proton ion, and divided by undissociated hydroxyacid on the basis of molar concentration. The acid strength is expressed as  $pK_a$ , and the latter is a negative logarithm of the dissociation constant. The hydroxyacid is a stronger acid if its  $pK_a$  number is lower (14). The acid strength of a hydroxyacid may not be related to its topical action on keratinization, although its  $pK_a$  is crucial to the determination of bioavailability and bioavailable concentration.

### Antioxidant Property

Oxidation is defined as removal of electrons or reaction with oxygen. An antioxidant is defined as any substance capable of preventing or inhibiting oxidation. In biological systems, an antioxidant may be described as a substance capable of disposing, scavenging or suppressing formation or actions of peroxide, superoxide or free radicals. There are three simple screen methods which are useful to determine antioxidant properties: prevention or retardation of air oxidation of (i) anthralin, (ii) hydroquinone, or (iii) banana peel. On the basis of the above three tests, all the PHAs and ABAs we have tested are antioxidants which include ribonolactone, gluconolactone, galactonolactone, gulonolactone, glucoheptonolactone, lactobionic acid and maltobionic acid (11,15,16). Among

AHAs and BHAs, citric acid, isocitric acid, tartaric acid and malic acid are antioxidants.

## HYDROXYACIDS: BIOCHEMISTRY

### Relationship to Amino Acids

Many hydroxyacids are related to or derived from amino acids. On the basis of chemical structures, the only difference between an AHA and an amino acid is the hydroxyl group instead of the amino group as shown in Table 10.5.

### Carbohydrate Metabolism and Citrate Cycle

Many hydroxyacids are intermediate products or end metabolites in carbohydrate metabolism; these include glyceric acid in glycolysis. In anaerobic glycolysis, D-glucose is converted to L-lactic acid as the end products. Gluconic acid and gluconolactone are important intermediates in pentose phosphate pathway for the synthesis of nucleotides in DNA and RNA. Gulonic acid and gulonolactone are carbohydrate intermediates for the synthesis of vitamin C in plants and some animals. Citric acid, isocitric acid and malic acid are important intermediates in the citrate cycle for energy production.

### Glycosaminoglycans

Glycosaminoglycans (GAGs) are large carbohydrates widely distributed in the body, for example, in skin, fibroblasts, mast cells, cartilage, bones, synovial fluid, cornea and loose connective tissues. Their physiological roles include formation of extracellular matrix; specific interactions with collagen and elastin; binding of water and ions; facilitating cell migration; formation of anticoagulants; and facilitating cell adhesion, cell interaction, and cell receptors. There are six different types of GAGs, namely hyaluronic acid, chondroitin sulfate, keratan sulfate I and II, dermatan sulfate, heparin and heparan sulfate. Each GAG is formed from two major carbohydrate components which include PHAs. For example, glucuronic acid is one of the two major components of hyaluronic acid, chondroitin sulfate and heparan sulfate. Iduronic acid is an important component of dermatan sulfate and heparin.

**Table 10.5** Biochemical Relationship Between Hydroxyacids and Amino Acids

Hydroxyacid and amino acid	Chemical structure
Glycolic acid	$\text{CH}_2\text{OHCOOH}$
Glycine	$\text{CH}_2\text{NH}_2\text{COOH}$
Lactic acid	$\text{CH}_3\text{CHOHCOOH}$
Alanine	$\text{CH}_3\text{CHNH}_2\text{COOH}$
Isopropylglycolic acid	$\text{C}_3\text{H}_7\text{CHOHCOOH}$
Valine	$\text{C}_3\text{H}_7\text{CHNH}_2\text{COOH}$
3-Isopropylactic acid	$\text{C}_3\text{H}_7\text{CH}_2\text{CHOHCOOH}$
Leucine	$\text{C}_3\text{H}_7\text{CH}_2\text{CHNH}_2\text{COOH}$
3-Methyl-3-ethyl-lactic acid	$(\text{C}_2\text{H}_5)\text{CH}(\text{CH}_3)\text{CHOHCOOH}$
Isoleucine	$(\text{C}_2\text{H}_5)\text{CH}(\text{CH}_3)\text{CHNH}_2\text{COOH}$
Glyceric acid	$\text{CH}_2\text{OHCHOHCOOH}$
Serine	$\text{CH}_2\text{OHCHNH}_2\text{COOH}$
3-Methylglyceric acid	$\text{CH}_3\text{CHOHCHOHCOOH}$
Threonine	$\text{CH}_3\text{CHOHCHNH}_2\text{COOH}$
Malic acid	$\text{HOOCCH}_2\text{CHOHCOOH}$
Aspartic acid	$\text{HOOCCH}_2\text{CHNH}_2\text{COOH}$
3-Phenyllactic acid	$\text{C}_6\text{H}_5\text{CH}_2\text{CHOHCOOH}$
Phenylalanine	$\text{C}_6\text{H}_5\text{CH}_2\text{CHNH}_2\text{COOH}$

## HYDROXYACIDS: BIOAVAILABILITY AND BIOAVAILABLE CONCENTRATION

### Stratum Corneum Barrier

In normal human skin, the stratum corneum consists of 14 to 30 layers of corneocytes including the inner level stratum compactum and the outer level stratum dysjunctum. The keratin-enriched corneocytes in the stratum corneum are embedded in a lipid matrix and are very resistant to penetration by ionic compounds or large molecules with molecular weight greater than 800 to 1000. While undissociated glycolic acid or lactic acid molecules can readily penetrate into the stratum corneum, the ionized glycolate or lactate anions from the metallic salt cannot. Although the active form of a hydroxyacid may be the anions once inside the skin, a topical formulation must contain a bioavailable form which can penetrate into and through the stratum corneum.

### Partial Neutralization and Buffered Formulation

A topical formulation containing a hydroxyacid without neutralization has a pH below 2. Since the pH of skin surface is approximately 4.2 to 5.6, many commercial products containing glycolic acid or lactic acid are partially neutralized with sodium hydroxide or ammonium hydroxide to pH 3.5 to 4.5, and claimed to be buffered formulations. A buffered system is designed to control pH changes of a formulation and does not effectively reduce or eliminate skin irritation without compromising topical efficacy. Therefore, lessened irritation is mainly due to decreased penetration of glycolic acid or lactic acid.

### Efficacy Potential

Cosmetic or therapeutic efficacy of a topical formulation containing a hydroxyacid is proportional to bioavailable concentration of the hydroxyacid in an optimal vehicle (13,14). The bioavailable concentration is obtained by bioavailability multiplied by initial total concentration of the hydroxyacid. The bioavailability is defined as a ratio or fraction of the undissociated hydroxyacid, because only the free acid, not the anion, can substantially penetrate the stratum corneum. Bioavailability decreases sharply when the pH is raised.

## HYDROXYACIDS: OPTIMAL-RELEASE FORMULATION

### Skin Stinging and Irritation

A topical formulation containing a hydroxyacid without partial neutralization usually has pH of below 2. Such formulation, especially with a small molecular AHA, may provoke sensations of tingling, itching, stinging or irritation when applied to sensitive, atopic, diseased or inflamed skin. The undesired skin reactions may be due to the lower pH of the formulation; or uncontrolled release and fast penetration of hydroxyacid into the skin. We have found that faster penetration of an AHA is the major factor in causing skin stinging (17).

### Molecular Complex

In an amphoteric system, the control-release mechanism is based on intermolecular attracting forces between a hydroxyacid and an amphoteric substance to form a molecular complex. Amino acids are the best amphoteric substances and the preferred ones are arginine, lysine, histidine, tryptophan and ornithine. There are three major attracting forces between a hydroxyacid and an amphoteric substance: ionic/ionic; dipolar/ionic; and

dipolar/dipolar (17). The amphoteric formulations are therapeutically effective with minimal or no irritations to the skin.

In a nonamphoteric system, the control-release mechanism is also based on intermolecular attracting forces between a hydroxyacid and a nonamphoteric substance to form a molecular complex. The nonamphoteric substances are multifunctional organic bases such as amino acid esters, amino acid amides, aminocarbohydrates, aminoalditols or aminocyclitols. Examples include glycine ethyl ester, glycylamide, arginylamide, lysinamide, ornithinamide, glucosamine, glucamine, meglumine and streptomine. In contrast to that of an amphoteric system, the main attracting force of a nonamphoteric system is from ionic/ionic force between a hydroxyacid anion and a cation of a nonamphoteric substance such as glycine ethyl ester ammonium ion. The nonamphoteric formulation is also therapeutically effective with minimal or no irritations to the skin.

## HYDROXYACIDS: TOPICAL ACTIONS

### Effects on Keratinization

On topical application hydroxyacids exert a profound effect on desquamation. At low to moderate concentrations, the hydroxyacid, such as glycolic acid 10% cream, on topical application to ichthyotic skin (Fig. 10.1) causes initial separation of stratum corneum at lower levels near stratum compactum (3,11). The separation of stratum corneum as a sheet indicates that topical action of the hydroxyacid is not a dispersive keratolysis, such as by salicylic acid. A similar event can also happen to normal skin. For example, DL-mandelic acid 10% cream on topical administration twice daily to normal skin causes sudden separation of stratum corneum as a thin sheet after a few days of application. The skin exposed after the separation of stratum corneum shows light pinkish coloration with a shiny smooth surface. With continued applications such desquamation returns to normal, that is, cannot be perceived. Because of their marked effects on desquamation, hydroxyacids can be topically effective for various cosmetic objectives.

### Effects on Dermal Components and Skin Thickness

Hydroxyacids at concentrations of 10% to 25% on topical application have been shown to increase biosynthesis of GAGs and collagen fibers, and also to improve the quality of photoaged elastic fibers (5,10,18,19). Hydroxyacid 10% to 35% creams topically applied twice daily to one forearm and control cream to the opposite forearm for one to nine months have been found to increase skin thickness very substantially (4,8). The increased skin thickness is mainly due to increased biosynthesis of GAGs and collagen fibers as shown by histological analysis (5,19). The degree of increase in skin thickness is quite variable, as shown in Table 10.6, and seems to depend on individual subject and the kind of hydroxyacid used. In some cases hydroxyacids have been found to increase skin thickness more than 40%. Although epidermal thickness is also increased, the major part of the increase in thickness is the dermis. The increased skin thickness is not due to edema formation, because it persists for many weeks to months after the discontinuation of topical application. Because of these dermal effects and increased skin thickness, hydroxyacids are found to be therapeutically effective for topical treatment of skin changes associated with aging, including wrinkles and photoaging.



**Figure 10.1** Thirteen-year-old girl with lamellar ichthyosis before (*left*) and after (*right*) topical application of 10% glycolic acid in hydrophilic ointment twice daily for three weeks.

**Table 10.6** Increased Skin Thickness by Topical Application of Hydroxyacids and Related Compounds<sup>a</sup>

Substance	Subject number	Age range (yr)	Duration (mo)	Percentage increase over control
Benzilic acid	2	68–72	2	22–45
Citric acid	13	50–83	5–9	7–55
Glycolic acid	4	58–77	4–8	11–43
Gluconolactone	6	62–81	2–7	7–19
Lactic acid	4	59–70	5–7	17–42
Lactobionic acid	7	49–76	1–3	5–58
Mandelic acid	2	55–62	1	22–27
Methylactic acid	3	65–76	1–3	14–20
Pyruvic acid	4	62–82	2	14–27

<sup>a</sup>10% to 35% concentration twice daily on forearm skin.

In contrast, under the same test conditions salicylic acid at 5% concentration has been found to cause a reduction in skin thickness, as shown in Table 10.7. Forearm skin treated with salicylic acid clinically appeared thinner.

**Peel Solutions and Skin Peeling**

Certain AHAs can be used in office procedures as peel solutions for topical treatment of various cosmetic and dermatological indications, including acne, keratoses, warts, wrinkles, and photoaging (20,21). The AHAs adaptable for such include glycolic acid, lactic acid, citric acid and mandelic acid. In wide use is glycolic acid in 20%, 35%, 50%, and 70% aqueous solutions containing small amount of ethanol and propylene

**Table 10.7** Decreased Skin Thickness by Topical Application of 5% Salicylic Acid Solution Twice Daily on Forearm Skin

Subject (age and gender)	Duration (wk)	Percentage decrease over control
57, F	8	-6
60, F	3	-7
59, F	6	-8
63, F	10	-11
61, F	2	-12
60, F	5	-14
67, F	6	-21
49, F	3	-23
73, F	7	-32

Abbreviation: F, female.

glycol for uniform penetration with pH 1.5, 1.35, 1.2, and 0.6, respectively (7,8). DL-Lactic acid can be used in the same manner, and 90% syrupy liquid having pH 0.5 is commercially available. Citric acid peel can be used as 20%, 30%, 40%, and 50% aqueous solution with pH 1.5, 1.4, 1.3, and 1.2, respectively. DL-Mandelic acid 50% in ethanol solution can be used for light desquamatory peeling.

Pyruvic acid, an  $\alpha$ -ketoacid, is the most powerful peeling agent but is unsuitable for clinical use because of its chemical instability. Glycolic acid 70% solution or DL-lactic acid 90% liquid can provoke epidermolysis on the facial skin, generally requiring several minutes of exposure depending on skin types. The clinical sign of epidermolysis is blanching of the skin, which indicates the threshold between superficial peeling and deeper peeling. For new patients it is best to begin with 20% or 35% glycolic acid solution and establish a reaction profile for each subject. In most cases the appearance of erythema is good indication that the skin will be peeled superficially. The peeling process should be terminated by neutralization with sodium bicarbonate solution or water. The patient may feel mild stinging but degrees of discomfort are mild to moderate and acceptable for the intended end result. Superficial peeling may be repeated at intervals of one to two weeks or longer to provide beneficial effects in acne, on acne-prone skin of younger age, on older skin prone to milia and comedones, on postacne scarring, on wrinkle-prone skin, on keratosis-prone skin and on photoaging skin.

For superficial peeling with milder reactions glycolic acid 50% in ethanol may be used. Application of this solution to facial skin is associated with rapid onset of a burning sensation and erythema. After one minute, the skin is rinsed with water or sodium bicarbonate solution to relieve the burning sensation. In most cases, the erythema fades within one to several hours. Epidermolysis can occur if glycolic acid 50% in ethanol is left on facial skin for several minutes. The erythema may persist into the next day with denudation of skin and degrees of serous oozing. In some cases, sheet-like separation of stratum corneum occurs one day after the procedure, leaving the skin light pink in color and smooth without other overt signs of an unwanted reaction. For most cosmetic procedures, superficial peeling with 50% or 70% glycolic acid is adequate and can be repeated every one to two weeks. For deeper peeling, glycolic acid 70% in water or 50% in ethanol can be left on the skin for longer periods, and can be so used in the treatment of seborrheic keratoses and actinic keratoses.

### Synergistic Compositions

Associated with the ability of hydroxyacids modulating keratinization and inducing biosynthesis of GAGs and collagen fibers is the capability of these natural and physiological substances to enhance or amplify pharmacological actions of many topical agents. Such topical agents include corticosteroids, retinoic acid, hydroquinone, diphenhydramine, 5-fluorouracil (5-FU), and antifungal agents (11,22). The mechanism of this synergistic action is not known. Perhaps it is because hydroxyacids disrupt skin barriers and promote better binding between a topical agent and its receptor molecule, resulting in enhanced topical effect. The enhanced therapeutic effects appear not due to an increased penetration of the topical agent into the skin. Hydroxyacids can also reduce or eliminate tachyphylaxis, as well as rebound worsening associated with topical corticosteroids. It has been found that

certain side-effects associated with topical corticosteroids, such as atrophy, can be reduced or avoided with concomitant use of an AHA (23).

## HYDROXYACIDS: MECHANISMS OF ACTION

### Specificity of Chemical Structure

Unique biological and biochemical actions of a hydroxyacid depend on specific chemical structure of the molecule, although its receptor molecule(s) in the skin has not been identified. Regarding the three attachment or binding sites, the hydroxyl group must be neutral and not acidic in chemical property, like the one in alcohol but not like aromatic phenol which is slightly acidic. The carboxyl group must be attached to a nonaromatic carbon, preferably an alkyl chain carbon. The amide or ester form is substantially less active than the free acid form. The side chain can be H, alkyl or aryl, but preferred one is a short chain. In the case of glycolic acid, the three attachment points or binding sites to a receptor molecule(s) in the skin are hydroxyl, carboxyl and one of the two hydrogen atoms attached to the  $\alpha$  carbon. Among related compounds, pyruvic acid is the most active and effective  $\alpha$ -ketoacid. In contrast to the hydroxyacid the ester form of pyruvic acid, such as methyl pyruvate and ethyl pyruvate, can be topically active. It has been speculated that the ester form is hydrolyzed to free pyruvic acid by an esterase enzyme in the skin.

### Biological Action

The precise mechanisms of actions induced by the hydroxyacid are not known. On the basis of the available laboratory and clinical data, hydroxyacids at different concentrations provide the following actions: diminished corneocyte cohesion at lower level of stratum corneum, near stratum compactum; a diminished number of desmosomes; reduced epidermal thickness in lamellar ichthyosis (Fig. 10.2); increased epidermal and dermal skin thickness in aging skin; increased synthesis of GAGs and collagen fibers; and increased activities of dermal dendrocytes (3,5,24).

### Biochemical Action

Biological actions are usually due to or caused by biochemical reactions. In normal stratum corneum, extractable lipids contain by weight approximately 45% to 50% ceramides, 25% cholesterol, 10% to 15% free fatty acids, and less than 5% each of other lipids including cholesterol-3-sulfate, which appears to be involved with cell cohesion in the lower layers of stratum corneum (25–27). The conversion of cholesterol-3-sulfate to cholesterol is required for normal desquamation of stratum corneum in the upper layers (28). It has been shown in X-linked ichthyosis that the skin is deficient in steroid sulfatase enzyme (29). While cholesterol is nonionic, cholesterol-3-sulfate is an ionic compound which may cause stronger intercorneocyte binding and cohesion, resulting in retarded desquamation. We might speculate that the hydroxyacid activates steroid sulfatase to enhance hydrolysis of cholesterol-3-sulfate to free cholesterol in the stratum compactum of ichthyotic skin. AHAs such as glycolic acid, lactic acid and citric acid have been shown to activate factor XIIIa transglutaminase enzyme, tumor necrosis factor- $\alpha$ , and to stimulate mast cells and dermal dendrocytes.





**Figure 10.2** Two-year-old girl with lamellar ichthyosis, including scaly skin and erythema, before (*top*) and after (*bottom*) twice daily topical application of 8% gluconolactone in control-release combination formulation for four weeks.

## HYDROXYACIDS: COSMETIC AND DERMATOLOGICAL INDICATIONS

### Dry Skin and Skin Smoothing

Hydroxyacids can modulate keratinization at the levels of stratum compactum, and such action is desirable for topical treatment of dry skin conditions. Most cosmetic products for dry skin contain humectants or moisturizers which tend to improve water content or prevent water loss from the stratum corneum. Although lactic acid has been claimed to be a moisturizer, most AHAs are not primary humectants or moisturizers. Rather, they modulate keratinization to normalize or improve the quality of stratum corneum so that water loss is minimized. Most AHAs and BHAs, 4% to 10% cream or lotion, are therapeutically effective for topical treatment or prevention of common dry skin or xerosis (30,31). PHAs and ABAs 5% to 10% concentration have extra benefits for dry skin because of multiple hydroxyl groups in the molecule, which seem to bind water molecules through hydrogen bondings. In addition, these hydroxyacids are gentle to sensitive or inflamed skin without causing skin stinging.

Hydroxyacids such as glycolic acid, lactic acid and mandelic acid at 10% concentration are therapeutically effective for topical treatment of ichthyosis and other severe dry skin

conditions. PHAs and ABAs such as gluconolactone, lactobionic acid and maltobionic acid 10% to 15%, alone or in combination with other topical agents, are beneficial and soothing for topical treatment of eczema and psoriasis. Combination of several hydroxyacids seems to be the best for topical treatment of severe dry skin.

## Acne and Rosacea

All acne lesions involve retention of follicular stratum corneum. Hydroxyacids are therefore therapeutically effective for topical management of acne (32). Topical action of a hydroxyacid at lower concentrations can diminish corneocyte cohesion and dislodge early comedones from follicular orifices (6). A gel or solution formulation in water, ethanol, propylene glycol 40:40:20 ratio containing 5% to 10% hydroxyacid and applied twice daily is usually quite beneficial for topical treatment or prevention of early acne. The hydroxyacids include glycolic acid, lactic acid, methylactic acid, mandelic acid and benzilic acid. In general, improvement of acne lesions is discernible within a few weeks of starting topical treatment.

For moderate to severe acne, hydroxyacids at higher skin peeling concentrations can be used to cause epidermolysis to unroof pustules and beneficially modulate follicular epithelium to the level of sebaceous glands (7,33). Glycolic acid 50% or 70% aqueous solution containing small amounts of alcohol and propylene glycol can be effectively used as peeling solution. The solution is applied to acne-involved areas with a cotton ball or suitable brush. The patient will feel a mild to moderate sense of burning as erythema develops over a period of a few minutes. When skin blanching or perifollicular edema is detected, the skin is rinsed with water, or neutralized with 5% sodium bicarbonate solution to stop further epidermolysis. With such procedure, most pustules will become unroofed. The procedure may be repeated every two to three weeks. During intervening periods, a low concentration such as 5% to 8% hydroxyacid in gel or solution may be used by the patient once or twice daily to keep follicles opened.

Rosacea is characterized by vascular dilatation with erythema near the center of the face. The cause is unknown, although sunlight may play an important role in the development of rosacea lesions. Rosacea lesions can evolve into telangiectasia with acneiform papules and pustules, and the skin is quite sensitive to many topical agents. Metronidazole 0.75% gel is beneficial for topical treatment of rosacea, but has no effect on telangiectasias. Because PHAs and ABAs are antioxidants and gentle to sensitive skin, substances such as gluconolactone, lactobionic acid, and maltobionic acid at 5% to 10% concentrations are beneficial for prophylactic as well as topical treatment of rosacea (34).

## Warts (Verrucae Vulgares)

Hydroxyacids are therapeutically effective for topical treatment of warts caused by human papillomavirus, which induces extreme degrees of hyperkeratoses (6). A rational approach to topical treatment includes: removing the hyperkeratotic "armor;" destroying the tissue harboring the virus; and introducing antiviral agent(s).

Much of the hyperkeratotic plate can be removed by scalpel paring. Thereupon an AHA in 70% solution or gel can be applied under occlusion twice daily by patients for a week or more to cause epidermolysis. In most cases destruction of wart tissue occurs by epidermolysis and is sufficient to

eradicate the virus as well as the lesion. However, combined use of an antimetabolite such as 5-FU is more curative, and can be applied concomitantly (7). For home use by patients, 0.5% 5-FU solution is prepared by dissolving the drug in 70% glycolic acid. The solution is applied twice daily with a cotton applicator to the center of a wart, which is then covered with tape. Applications are discontinued if discomfort occurs, and resumed if the wart lesion is not yet resolved. We have found that the foregoing treatment usually results in complete resolution of lesions within three to four weeks.

### Eczema and Pruritus

Eczema may be defined as persistent inflammatory skin lesions with constant or repeated itch. Eczematous disorders can occur at any age and in various forms, such as nummular eczema and lichen simplex chronicus, and is a very common skin disease in Asian countries. Eczema may be caused by endogeneous and exogeneous factors. Pruritus is the main disturbance. Corticosteroids have been used for topical treatment of eczema and the pruritus diminishes secondarily as inflammatory process is subdued. In cases of eczema wherein inflammation is not a primary event, topical corticosteroids are not very effective in eradicating the pruritus. Hydroxyacids such PHAs and ABAs incorporated into topical antipruritic formulations can greatly enhance efficacy. For example, addition of gluconolactone, lactobionic acid and/or maltobionic acid to diphenhydramine topical formulations greatly enhance antipruritic efficacy. The best results are obtained when gluconolactone, lactobionic acid and/or maltobionic acid is combined with hydrocortisone-17-valerate and diphenhydramine in cream or lotion vehicles.

### Onychomycosis

Onychomycosis is a paramount cosmetic affliction, heretofore difficult to treat. When an AHA is incorporated into a composition containing an antifungal drug, the formulation becomes topically very effective for nail infections. Improvement of fingernail and toenail infections progresses at the rate of nail growth; approximately 1 mm/wk for a fingernail and 0.5 mm/wk for a great toenail. The improvement rates also suggest that fungal infection of a nail is arrested by the topical treatment with synergistic compositions containing both AHA and antifungal drug. Fungal infections of finger nails have been regularly eradicated with up to six months of topical treatment with solutions containing 2% clotrimazole and 20% glycolic acid.

### Hydroxyacids: Intrinsic and Extrinsic Skin Aging

Cutaneous aging is caused by internal and external factors (35–38). Intrinsic aging is a physiological degeneration caused by declining ability and functions inherent with increasing age. Upper arms and buttocks are typical skin areas showing intrinsic aging, where the skin thins and has fine wrinkles. Daily topical application of glycolic acid, gluconolactone or lactobionic acid 5% to 10% cream or lotion has been found to be beneficial for prophylactic as well as topical treatment of sun protected areas of aging skin.

Extrinsic aging is a combination of intrinsic aging and an accelerated degeneration caused by ultraviolet (UV) radiation, ionizing radiation, air pollution, wind, cold, heat, dampness, chemicals, smoke and cigarette smoking. Face and hands are typical skin areas showing extrinsic skin aging. Photoaged skin



**Figure 10.3** Fifty-five-year-old woman with photoaged skin, including coarse wrinkles and textural signs of elastosis on her face, before (*left*) and after (*right*) 70% glycolic acid peels monthly and home use of twice daily 10% glycolic acid cream for nine months.

is rough, dry, mottled, yellowish, leathery, and thickened. It lacks elasticity, has keratoses and pigmented age spots, and coarse and deep wrinkles. Aging of the face and the hands in elderly people is due to a combination of intrinsic aging and photoaging. Physiological aging cannot be stopped, but signs of extrinsic cutaneous aging can be modified by topical application of AHAs, PHAs, ABAs or combinations to improve appearance and slow the process (Fig. 10.3) (39–42).

### Sunburn Cells

Sunburn cells are dead or dying keratinocytes caused by UV radiation, and are physiologically programmed for cell death (apoptosis). The cells are eosinophilic and appear in the epidermis within 30 minutes, and are maximal at 24 hours, after UVB radiation (290–320 nm) (43). The action spectrum appears to be just below 300 nm, and UVA (320–400 nm) radiation does not seem to produce any detectable or significant numbers of sunburn cells in epidermis. The mechanism of action is unknown. It appears that DNA damages have occurred in certain keratinocytes at the lower epidermis after the UVB radiation, and these sunburn cells move rapidly upward through the epidermis into the stratum corneum.

Preliminary study showed that glycolic acid 10%, pH 3.5, on topical application for 12 weeks decreased minimal erythema dose by 18%, and increased the number of sunburn cells by twofold, as compared with control group (44). Under the same test conditions, a cosmetic surfactant, sodium lauryl sulfate at 0.5% concentration increased the number of sunburn cells sixfold. Topical formulations containing an AHA and a sunscreen agent with a sun protection factor (SPF) approximately 3 to 4, appeared to prevent any increase of sunburn cells (45). Topical formulations containing a PHA, 5% to 10% gluconolactone, without any sunscreen agent have been shown to provide therapeutic effects and protect the skin from any increase in sunburn cells (46).

Nevertheless, regular use of a sunscreen is advisable.

### Actinic Keratoses

Actinic keratosis is a precancerous lesion of keratinocytes, also called solar keratosis which is caused by photodamage. The lesions are on the sun-exposed areas of skin. Actinic keratosis may progress to squamous cell carcinoma. One conventional treatment is continued topical application of 5-FU for several weeks. A combination of a hydroxyacid and 5-FU can shorten the treatment time and the period of discomfort from several weeks to just one week. First, the lesions or sites of actinic keratoses are identified by topical application of 5% 5-FU cream twice daily to affected areas for five to seven days before the office procedure. Once the lesions are identified, 70% glycolic acid in ethanol:propylene glycol 80:20 is applied to the lesions. After two to five minutes when the lesions begin to blanch, 5% 5-FU solution is applied.

Alternatively, the lesions may be treated with 0.5% to 1% 5-FU dissolved in 30% glycolic acid aqueous solution (7). In most cases, the above procedure results in complete eradication of the lesions.

### Age Spot Keratoses

Aging related macules and papules on the face and the back of the hands are pigmented lentiginos, nonpigmented keratoses and/or seborrheic keratoses. For rapid removal of keratoses, 100% pyruvic acid, 90% lactic acid or 70% glycolic acid peel solutions may be used as an office procedure (Fig. 10.4). After the area is degreased with 70% ethanol, the peel solution is applied with a fine camel-hair brush, and the skin is neutralized with 5% sodium bicarbonate solution when epidermolysis occurs. Among the above peel solutions, 70% glycolic acid is preferred. The skin peel may be repeated after an interval of several weeks to eradicate remaining lesions. Home treatment with a cream or gel containing 10% hydroxyacid with or without 2% hydroquinone may be continued to subdue reemergence or new lesions. Age spots on the dorsa of the hands and forearms, more resistant to simple topical treatment, may need sustained treatment with 20% or higher concentration of hydroxyacid (7). The addition of hydroquinone seems more



**Figure 10.4** Eighty-year-old woman with photodamaged skin, including coarse wrinkles and multiple lesions of actinic keratoses on her face, before (*left*) and after (*right*) 70% glycolic acid peels and home use of 10% glycolic acid cream for four years.



**Figure 10.5** Sixty-three-year-old man with age spots, including multiple lesions of seborrheic keratoses and lentiginos on his left face, before (*left*) and after (*right*) twice daily topical application of 10% glycolic acid and 2% hydroquinone cream for 21 months.

effective in the eradication of pigmented skin spots such as lentiginos and freckles (Fig. 10.5). The time required for their clinical resolution is quite variable, from a few months to a year or more.

### Wrinkles and Aging Skin

AHAs are therapeutically effective for topical treatment of skin changes associated with aging, because they increase skin thickness by stimulating biosynthesis of GAGs and collagen fibers. An AHA such as glycolic acid at concentration of 10% can be used by a patient at home to treat fine wrinkles on the face (6,7). Substantial improvement may be perceived after several months of treatment. However, the time required for clinical improvement of coarse wrinkles may take years, depending on the degree of severity. Office procedures using 90% lactic acid or 70% glycolic acid peels seem to provide faster resolution of coarse wrinkles, combined with sustained home use of an AHA at or near 10% concentration (8,40,47).

Five parameters may be used to monitor the progress of therapeutic effects: improvement in dyspigmentation, skin texture, overt fine lines and wrinkles, and increased skin thickness. It is essential that "before" and "after" photos be taken for each patient to assess progress.

### Antioxidants and Photoaging

The human body needs oxygen for energy and life itself. Therefore, oxidation is inherent to living. Reactive oxygen species (ROS) are produced by oxidation or peroxidation, and include superoxide, hydrogen peroxide, hydroxyl radicals and peroxy radicals (48,49). Among these ROS, the hydroxyl radicals are most reactive and cause cellular and tissue stress by reacting with proteins, nucleic acids, lipids and other biochemical entities. Under quiescent conditions, endogenous or available antioxidants and reductive enzymes in the body are capable of neutralizing these harmful ROS. Known antioxidants and enzymes include vitamin C, vitamin E, reduced

$\alpha$ -lipoic acid, reduced ubiquinones (coenzyme Q), reduced glutathione (GSH), reduced nicotinamide adenine dinucleotide phosphate (NADPH), and superoxide dismutase, which converts superoxide to hydrogen peroxide and oxygen. Catalase and glutathione peroxidase in turn convert hydrogen peroxide to water and oxygen. Many other antioxidants probably have ancillary or primary roles.

Sunlight is essential for life on earth, but UV radiation is harmful to human skin. Human skin is equipped with antioxidant systems that counteract or dispose of some ROS induced by UVB (50). However, the amount of these endogenous or available antioxidants may not be sufficient to overcome the increased ROS produced by continued exposure to UVB. The skin reactions or damages caused by UVB include erythema, edema, exfoliation, tanning, abnormal thickening (elastosis) or thinning of the epidermis and dermis, and numerous other changes known as photoaging including carcinogenesis.

Hydroxyacids have been shown to improve the appearance of photoaged skin by improving epidermal renewal and desquamation, and by increasing dermal biosynthesis of GAGs and collagen fibers (5,10). Because PHAs and ABAs are antioxidants, they can be used to prevent or to counteract ROS induced in the skin by UVB, in conjunction with sunscreens and sunblocks in cream, lotion or gel form to prevent sun damage (34).

### Similarities and Differences of Hydroxyacids

The chemical structure of a hydroxyacid determines whether the substance belongs to AHA, BHA, PHA or ABA, and such classification is also based on its characteristics and usage. Different members of the same group may possess different physicochemical properties, for example, hydrophilic or lipophilic, but they have similarities in their topical actions with different degrees of potency; these include glycolic acid, lactic acid, and mandelic acid. We have found that BHAs as a group are similar to AHAs in many ways, and the same is true between ABAs and PHAs. However, PHAs and ABAs are functionally different from AHAs and BHAs in some aspects, as shown in Table 10.8. Because of multiple hydroxyl groups in the molecule, PHAs and ABAs are antioxidants, gentle to the skin, and they do not increase sunburn cells following UV radiation. Certain members of PHAs, such as glucuronic acid and iduronic acid, are known constituents of GAGs. In the past

years, AHAs, especially glycolic acid have been used quite extensively for cosmetic and dermatological indications. In recent years, PHAs and ABAs, such as gluconolactone and lactobionic acid, are used as unique ingredients in cosmetic products.

### Antagonistic Acetoxyacids

Like some substances with antagonists in nature, hydroxyacids appear to have their own antagonistic counterparts. When the hydroxyl group at the  $\alpha$  position of an AHA is acetylated to an acetoxy compound, the modulation on keratinization changes to reverse direction, causing hyperkeratinization. The antagonistic action is noticeably pronounced when an aralkyl AHA such as mandelic acid, benzilic acid or phenyllactic acid is acetylated to *O*-acetyl-mandelic acid, *O*-acetyl-benzilic acid or *O*-acetyl-phenyllactic acid, respectively. Aralkyl *O*-acetyl-AHA 5% to 10% creams have been shown to increase thickness and compactness of stratum corneum in hairless mouse and human forearms (3). The hyperkeratotic action of aralkyl *O*-acetyl-AHAs has been found to be useful and effective for topical treatment of brittle nails, psoriatic nails and cheilitis caused by oral administration of 13-*cis*-retinoic acid.

### N-Acetylamino Acids and N-Acetyl Compounds

An amino acid is a substituted organic acid, in which one H at the  $\alpha$  carbon atom is replaced by an amino group, and NAA is obtained by *N*-acetylation of the amino group. In fact, the NAA can be considered as the organic acid in which one H is replaced by an acetamino group. There are 20 common amino acids present as L form in natural proteins, and there are also a number of related amino acids with different chemical structures and configurations. These common amino acids and related amino acids can form NAAs and related *N*-acetyl compounds. *N*-Acetylglucosamine, *N*-acetylgalactosamine, and *N*-acetylmannosamine are *N*-acetylated derivatives of aminocarbohydrates; glucosamine, galactosamine and mannosamine which are organic aldehydes instead of organic acids. Topical actions of *N*-acetylglucosamine and *N*-acetylgalactosamine have some similarities as that of NAA as shown in Table 10.9. We have found that *N*-acetyl-L-proline and *N*-acetyl-D-glucosamine at 5% to 10% concentration are topically effective for ichthyosis and also for eradication of itch associated with eczema and xerosis.

**Table 10.8** Similarities and Differences in Characteristics and Use of Hydroxyacids

Characteristics/use	$\alpha$ -Hydroxyacids	$\beta$ -Hydroxyacids	Polyhydroxy acids	Aldobionic acids
Physiological nutrients or natural substances	+	+	+	+
Antioxidants against superoxides, free radicals	<sup>a</sup>		+	+
Gentle to sensitive skin			+	+
Gel matrix formation/wound healing				+
Constituents of GAGs			+	
Modulate keratinization, dry skin, acne, keratoses	+	+	+	+
Increase dermal components	+	+	+	+
GAGs, collagen, elastin, wrinkles, photoaging				
Synergistic effects of corticosteroids, antifungal agents	+	+	+	+

<sup>a</sup>Polycarboxy AHAs; malic acid, citric acid, and tartaric acid are antioxidants.  
Abbreviation: GAGs, glycosaminoglycans.

**Table 10.9** *N*-Acetylamino Acids and *N*-Acetyl Compounds

Chemical name	Chemical structure	Topical effects	
		Ichthyosis	Itch
<i>N</i> -Acetyl-L-alanine	CH <sub>3</sub> CH(NHCOCH <sub>3</sub> ) COOH		
<i>N</i> <sub>2</sub> -Acetyl-L-arginine	H <sub>2</sub> NC(=NH)NH(CH <sub>2</sub> ) <sub>3</sub> CH(NHCOCH <sub>3</sub> ) COOH		
<i>N</i> -Acetyl-L-aspartic acid	HOOC CH <sub>2</sub> CH(NHCOCH <sub>3</sub> ) COOH		
<i>N</i> -Acetyl-DL-asparagine	H <sub>2</sub> NOC CH <sub>2</sub> CH(NHCOCH <sub>3</sub> ) COOH	4+	
<i>N</i> -Acetyl-L-cysteine	HSCH <sub>2</sub> CH(NHCOCH <sub>3</sub> ) COOH	3+	
<i>N</i> -Acetyl-glycine	CH <sub>2</sub> (NHCOCH <sub>3</sub> ) COOH	3+	
<i>N</i> -Acetyl-L-glutamic acid	HOOC CH <sub>2</sub> CH <sub>2</sub> CH(NHCOCH <sub>3</sub> ) COOH	4+	
<i>N</i> -Acetyl-L-glutamine	H <sub>2</sub> NOC CH <sub>2</sub> CH <sub>2</sub> CH(NHCOCH <sub>3</sub> ) COOH		4+
<i>N</i> -Acetyl-L-histidine	C <sub>3</sub> H <sub>3</sub> N <sub>2</sub> CH <sub>2</sub> CH(NHCOCH <sub>3</sub> ) COOH		
<i>N</i> -Acetyl-L-isoleucine	CH <sub>3</sub> CH <sub>2</sub> CH(CH <sub>3</sub> ) CH(NHCOCH <sub>3</sub> ) COOH		
<i>N</i> -Acetyl-L-leucine	(H <sub>3</sub> C) <sub>2</sub> CH CH <sub>2</sub> CH(NHCOCH <sub>3</sub> ) COOH		
<i>N</i> <sub>2</sub> -Acetyl-L-lysine	H <sub>2</sub> NCH <sub>2</sub> (CH <sub>2</sub> ) <sub>3</sub> CH(NHCOCH <sub>3</sub> ) COOH		4+
<i>N</i> -Acetyl-L-methionine	(H <sub>3</sub> C)SCH <sub>2</sub> CH <sub>2</sub> CH(NHCOCH <sub>3</sub> ) COOH		
<i>N</i> -Acetyl-L-phenylalanine	C <sub>6</sub> H <sub>5</sub> CH <sub>2</sub> CH(NHCOCH <sub>3</sub> ) COOH		
<i>N</i> -Acetyl-L-proline	N(COCH <sub>3</sub> )C <sub>4</sub> H <sub>7</sub> COOH	4+	4+
<i>N</i> -Acetyl-L-serine	HOCH <sub>2</sub> CH <sub>2</sub> (NHCOCH <sub>3</sub> ) COOH		
<i>N</i> -Acetyl-L-threonine	H <sub>3</sub> C CHOH CH(NHCOCH <sub>3</sub> ) COOH		
<i>N</i> -Acetyl-L-tryptophan	C <sub>8</sub> H <sub>6</sub> N CH <sub>2</sub> CH(NHCOCH <sub>3</sub> ) COOH		
<i>N</i> -Acetyl-L-tyrosine	HOC <sub>6</sub> H <sub>4</sub> CH <sub>2</sub> CH(NHCOCH <sub>3</sub> ) COOH	4+	
<i>N</i> -Acetyl-L-tyrosinamide	HOC <sub>6</sub> H <sub>4</sub> CH <sub>2</sub> CH(NHCOCH <sub>3</sub> ) CONH <sub>2</sub>	4+	
<i>N</i> -Acetyl-L-valine	(H <sub>3</sub> C) <sub>2</sub> CH CH(NHCOCH <sub>3</sub> ) COOH		
<i>N</i> -Acetyl-β-alanine	CH <sub>2</sub> (NHCOCH <sub>3</sub> ) CH <sub>2</sub> COOH	4+	
<i>N</i> -Acetyl-γ-aminobutanoic acid	CH <sub>2</sub> (NHCOCH <sub>3</sub> ) CH <sub>2</sub> CH <sub>2</sub> COOH	3+	
<i>N</i> <sub>2</sub> -Acetyl-L-ornithine	H <sub>2</sub> NCH <sub>2</sub> (CH <sub>2</sub> ) <sub>2</sub> CH(NHCOCH <sub>3</sub> ) COOH		
<i>N</i> -Acetyl-L-citrulline	H <sub>2</sub> NCONH(CH <sub>2</sub> ) <sub>3</sub> CH(NHCOCH <sub>3</sub> ) COOH		
<i>N</i> -Acetyl-creatine	H <sub>2</sub> NC(=NCOCH <sub>3</sub> )N(CH <sub>3</sub> ) CH <sub>2</sub> COOH		
<i>N</i> -Acetyl-creatinine	—HNC(=NCOCH <sub>3</sub> )N(CH <sub>3</sub> ) CH <sub>2</sub> CO—		
<i>N</i> -Acetyl-phenylglycine	C <sub>6</sub> H <sub>5</sub> CH(NHCOCH <sub>3</sub> ) COOH		
<i>N</i> -Acetyl-4-hydroxyphenylglycine	HOC <sub>6</sub> H <sub>4</sub> CH(NHCOCH <sub>3</sub> ) COOH	3+	
<i>N</i> -Acetyl-D-glucosamine	HOH <sub>2</sub> C (CHOH) <sub>3</sub> CH(NHCOCH <sub>3</sub> ) CHO	4+	4+
<i>N</i> -Acetyl-D-galactosamine	HOH <sub>2</sub> C (CHOH) <sub>3</sub> CH(NHCOCH <sub>3</sub> ) CHO	4+	

Note: Ichthyosis: 3+, 75%; 4+, 100% improvement.

Itch: 4+, eradicate itch completely for eight hours.

Some NAAs and *N*-acetylaminocarbohydrates occur in nature as metabolites, biopeptides, glycoproteins or GAGs, for example, *N*-acetyl-L-glutamic acid in liver (51), *N*-acetyl-L-aspartic acid in brain (51), *N*-acetyl-L-serine in α-melanocyte-

stimulating hormone (α-MSH) (52), *N*-acetyl-L-tyrosine in *N*-acetyl-β-endorphin (52), *N*-acetyl-D-glucosamine in hyaluronic acid and keratan sulfate (53), and *N*-acetyl-D-galactosamine in chondroitin sulfate and dermatan sulfate (53).



**Figure 10.6** Six-year-old boy with lamellar ichthyosis before (*left*) and after (*right*) topical application of 8% *N*-acetyl-L-cysteine in hydrophilic ointment twice daily for four weeks.

**Table 10.10** *N*-Phosphonomethylamino Acids and Related Compounds

Chemical name	Chemical structure	Topical effects	
		Ichthyosis	Itch
<i>N</i> -Phosphonomethyl-L-alanine	CH <sub>3</sub> CH(NHR) COOH		
<i>N</i> <sub>2</sub> -Phosphonomethyl-L-arginine	H <sub>2</sub> NC(=NH)NH(CH <sub>2</sub> ) <sub>3</sub> CH(NHR) COOH		
<i>N</i> -Phosphonomethyl-L-aspartic acid	HOOC CH <sub>2</sub> CH(NHR) COOH		
<i>N</i> -Phosphonomethyl-DL-asparagine	H <sub>2</sub> NOC CH <sub>2</sub> CH(NHR) COOH	4+	
<i>N</i> -Phosphonomethyl-L-cysteine	HSCH <sub>2</sub> CH(NHR) COOH		
<i>N</i> -Phosphonomethyl-glycine	CH <sub>2</sub> (NHR) COOH	4+	
<i>N</i> -Phosphonomethyl-L-glutamic acid	HOOC CH <sub>2</sub> CH <sub>2</sub> CH(NHR) COOH		
<i>N</i> -Phosphonomethyl-L-glutamine	H <sub>2</sub> NOC CH <sub>2</sub> CH <sub>2</sub> CH(NHR) COOH	4+	4+
<i>N</i> -Phosphonomethyl-L-histidine	C <sub>3</sub> H <sub>3</sub> N <sub>2</sub> CH <sub>2</sub> CH(NHR) COOH		
<i>N</i> -Phosphonomethyl-L-isoleucine	CH <sub>3</sub> CH <sub>2</sub> CH(CH <sub>3</sub> ) CH(NHR) COOH		
<i>N</i> -Phosphonomethyl-L-leucine	(H <sub>3</sub> C) <sub>2</sub> CH CH <sub>2</sub> CH(NHR) COOH		
<i>N</i> <sub>2</sub> -Phosphonomethyl-L-lysine	H <sub>2</sub> NCH <sub>2</sub> (CH <sub>2</sub> ) <sub>3</sub> CH(NHR) COOH		
<i>N</i> -Phosphonomethyl-L-methionine	(H <sub>3</sub> C)SCH <sub>2</sub> CH <sub>2</sub> CH(NHR) COOH		
<i>N</i> -Phosphonomethyl-L-phenylalanine	C <sub>6</sub> H <sub>5</sub> CH <sub>2</sub> CH(NHR) COOH		
<i>N</i> -Phosphonomethyl-L-proline	N(R)C <sub>4</sub> H <sub>7</sub> COOH		
<i>N</i> -Phosphonomethyl-L-serine	HOCH <sub>2</sub> CH <sub>2</sub> (NHR) COOH		
<i>N</i> -Phosphonomethyl-L-threonine	H <sub>3</sub> C CHOH CH(NHR) COOH		
<i>N</i> -Phosphonomethyl-L-tryptophan	C <sub>8</sub> H <sub>6</sub> N CH <sub>2</sub> CH(NHR) COOH		
<i>N</i> -Phosphonomethyl-L-tyrosine	HOC <sub>6</sub> H <sub>4</sub> CH <sub>2</sub> CH(NHR) COOH	3+	
<i>N</i> -Phosphonomethyl-L-valine	(H <sub>3</sub> C) <sub>2</sub> CH CH(NHR) COOH		
<i>N</i> -Phosphonomethyl-β-alanine	CH <sub>2</sub> (NHR) CH <sub>2</sub> COOH		
<i>N</i> -Phosphonomethyl-γ-aminobutanoic acid	CH <sub>2</sub> (NHR) CH <sub>2</sub> CH <sub>2</sub> COOH		
<i>N</i> <sub>2</sub> -Phosphonomethyl-L-ornithine	H <sub>2</sub> NCH <sub>2</sub> (CH <sub>2</sub> ) <sub>2</sub> CH(NHR) COOH		
<i>N</i> -Phosphonomethyl-L-citrulline	H <sub>2</sub> NCONH(CH <sub>2</sub> ) <sub>3</sub> CH(NHR) COOH		
<i>N</i> -Phosphonomethyl-creatine	H <sub>2</sub> NC(=NR)N(CH <sub>3</sub> ) CH <sub>2</sub> COOH	4+	
<i>N</i> -Phosphonomethyl-creatinine	—HNC(=NR)N(CH <sub>3</sub> ) CH <sub>2</sub> CO—		
<i>N</i> -Phosphonomethyl-phenylglycine	C <sub>6</sub> H <sub>5</sub> CH(NHR) COOH		
<i>N</i> -Phosphonomethyl-4-hydroxyphenylglycine	HOC <sub>6</sub> H <sub>4</sub> CH(NHR) COOH		

Note: R: CH<sub>2</sub>PO(OH)<sub>2</sub>.

Ichthyosis: 3+, 75%; 4+, 100% improvement.

Itch: 4+, eradicate itch completely for eight hours.

NAC is a potent antioxidant against free radicals such as hydroxyl radical (54), and is a good precursor for glutathione synthesis in the body. NAC is used as a mucolytic, detoxifying, and antiviral agent. We have found that NAC 8% in hydrophilic ointment is topically effective for ichthyosis (Fig. 10.6).

An amino acid can be in amide or hydrazide form, for example, *N*-acetylamino amide and *N,N'*-diacetylamino hydrazide. We have found that *N*-acetyl-L-tyrosinamide and *N,N'*-diacetyl-L-tyrosinhydrazide in oil-in-water emulsion on topical application to normal human skin can stimulate biosynthesis of hyaluronic acid, and increase skin thickness.

### ***N*-(Phosphonomethyl)amino Acids**

NPA is derived from an amino acid by substituting one hydrogen atom of the amino group with phosphonomethyl radical, for example, *N*-(phosphonomethyl)glycine. Because an amino group has two hydrogen atoms, an amino acid can have two phosphonomethyl radicals, for example, *N,N*-bis(phosphonomethyl)glycine. The common amino acids and related amino acids can form NPAs or *N,N*-bis(phosphonomethyl)amino acids.

*N*-(Phosphonomethyl)glycine is known as glyphosate. The isopropylamine salt of *N*-(phosphonomethyl)glycine is a primary active ingredient in Roundup<sup>®</sup> herbicide (55). *N,N*-bis(phosphonomethyl)glycine is known as glyphosine, which is used as plant growth regulator to cause chlorosis in green plants, and is also used as a chemical ripener (55).

We have found that some NPAs are topically effective for ichthyosis; *N*-phosphonomethyl-L-glutamine also effective for eradication of itch in eczema as shown in Table 10.10.

### **CONCLUSION, DISCUSSION, AND PERSPECTIVES**

Organic acids cover various organic compounds which include retinoic acid, salicylic acid, AHAs, PHAs, ABAs, NAAs, and NPAs. On topical administration, these organic acids exert distinctive pharmacological actions on keratinization and/or biosynthesis of dermal components, that is, GAGs, collagen and elastic fibers. However, these organic acids also have certain similarities and differences in topical actions. Both salicylic acid and glycolic acid have similar beneficial effects on disturbed keratinization, for example, acne, ichthyosis, calluses, etc. Glycolic acid increases while salicylic acid diminishes the biosynthesis of dermal components, that is, glycolic acid but not salicylic acid is beneficial for wrinkles and aging skin. Both NAAs and NPAs have similar beneficial effects on disturbed keratinization, for example, ichthyosis and hyperkeratoses. In addition, some NAAs have beneficial effects on itch associated with eczema and xerosis.

Topical effects of most organic acids appear to be in free acid form, and the amide or ester form seems ineffective or much less effective, for example, retinoic acid, glycolic acid, and salicylic acid. For NAAs, the amide or ester form appears more effective for topical treatment of itch and aging related skin changes. *N*-Acetyl-L-proline ethyl ester appears more

effective than *N*-acetyl-L-proline for topical treatment of itch associated with eczema. *N*-Acetyl-L-tyrosinamide is more effective than *N*-acetyl-L-tyrosine for increasing the skin thickness by stimulation of hyaluronic acid biosynthesis. *N*-Acetyl-L-glutamic acid diethyl ester is more effective than *N*-acetyl-L-glutamic acid for topical treatment of ichthyosis. On the basis of these observations, the active form of the NAA may not be in free acid or anion form.

Since 1974, many studies have shown that physiological and nontoxic hydroxyacids can promote normal keratinization and increase synthesis of dermal components, including hyaluronic acid and collagen fibers. AHAs, especially glycolic acid, have been widely used in cosmetic products and dermatological practice for topical treatment of dry skin, acne, keratoses, wrinkles, photoaging, and photodamaged skin. Because of multiple hydroxyl groups in the molecules, gluconolactone (a PHA lactone) and lactobionic acid (an ABA) are gentle to the skin and are antioxidants.

We are fortunate at this time of general awareness and concern over aging, photoaging, photodamage, and environmental and disease impingements disfiguring the integument that an entire category of physiological and nontoxic substances can be drawn on to repair or prevent such disfigurements. The hydroxyacids and other organic acids can be utilized to nudge skin form and function toward a more youthful state. They can be topically applied to decelerate the otherwise inexorable progression toward old-looking integument.

The antioxidant PHAs and ABAs are especially beneficial and can be utilized to repair and prevent damages caused by UV radiations. However, these latter substances are still new on the scene, and an expanding use is projected. Dermatologists, cosmetologists, pharmacologists, pharmacists and formulators need to be closely familiar with chemical attributes of the various hydroxyacids and other organic acids including PHAs and ABAs, their clinical performance and how best to design and compound formulations to provide maximal achievement of intended objectives.

## REFERENCES

1. Van Scott EJ, Yu RJ. Control of keratinization with the alpha hydroxy acids and related compounds. *Arch Dermatol* 1974; 110:586-590.
2. Van Scott EJ, Yu RJ. Substances that modify the stratum corneum by modulating its formation. In: Frost P, Horwitz SN, eds. *Principles of Cosmetics for the Dermatologist*. St. Louis: CV Mosby, 1982:70-74.
3. Van Scott EJ, Yu RJ. Hyperkeratinization, corneocyte cohesion, and hydroxy acids. *J Am Acad Dermatol* 1984; 111:867-879.
4. Van Scott EJ, Yu RJ. Actions of alpha hydroxy acids on skin compartments. *J Geriatr Dermatol* 1995; 3:19A-25A.
5. Ditre CM, Griffin TD, Murphy GF, et al. Effects of alpha-hydroxy acids on photoaged skin. A pilot clinical, histologic, and ultrastructural study. *J Am Acad Dermatol* 1996; 34:187-195.
6. Van Scott EJ, Yu RJ. Alpha hydroxy acids. Procedures for use in clinical practice. *Cutis* 1989; 43:222-228.
7. Van Scott EJ, Yu RJ. Alpha hydroxy acids. Therapeutic potentials. *Can J Dermatol* 1989; 1:108-112.
8. Van Scott EJ, Ditre CM, Yu RJ. Alpha-hydroxyacids in the treatment of signs of photoaging. *Clin Dermatol* 1996; 14:217-226.
9. Newman N, Newman A, Moy LS, et al. Clinical improvement of photodamaged skin with 50% glycolic acid. A double blind vehicle-controlled study. *Dermatol Surg* 1996; 22:455-460.
10. Bernstein EF, Underhill CB, Lakkaakorpi J, et al. Citric acid increases viable epidermal thickness and glycosaminoglycan content of sun-damaged skin. *Dermatol Surg* 1997; 23:689-694.
11. Yu RJ, Van Scott EJ. Hydroxycarboxylic acids, N-acetylamino sugars, and N-acetylamino acids. *Skinmed* 2002; 1:117-122.
12. Yu RJ, Van Scott EJ. Salicylic acid. Not a beta-hydroxy acid. *Cosmet Dermatol* 1997; 10:27.
13. Yu RJ, Van Scott EJ. Bioavailability of alpha-hydroxy acids in topical formulations. *Cosmet Dermatol* 1996; 9:954-962.
14. Yu RJ, Van Scott EJ. Bioavailable alpha hydroxy acid in topical formulations. In: Moy R, Luftman D, Kakita L, eds. *Glycolic Acid Peels*. New York: Marcel Dekker, 2002:15-28.
15. Green BA, Briden ME. PHAs and bionic acids: next generation hydroxy acids. In: Draelos Z, Dover J, Alam M, eds. *Procedures in Cosmetic Dermatology: Cosmeceuticals*. 2nd ed. Philadelphia: Elsevier Saunders, 2009:209-215.
16. Yu RJ, Van Scott EJ. Alpha-hydroxy acids. Science and therapeutic use. *Cosmet Dermatol* 1994; 10(suppl):12-20.
17. Yu RJ, Van Scott EJ. A discussion of control-release formulations of AHAs. *Cosmet Dermatol* 2001; 10:15-18.
18. Bernstein EF. Dermal effects of alpha hydroxy acids. In: Moy R, Luftman D, Kakita L, eds. *Glycolic Acid Peels*. New York: Marcel Dekker, 2002:71-113.
19. Bernstein EF, Lee J, Brown DB. Glycolic acid treatment increases type I collagen mRNA and hyaluronic acid content of human skin. *Dermatol Surg* 2001; 27:429-433.
20. Rubin MG. Glycolic acid peels. In: Rubin MG, ed. *Manual of Chemical Peels*. Philadelphia: Lippincott, 1992:89-102.
21. Drake LA, Dinehart SM, Goltz RW, et al. Guidelines of care for chemical peeling. *J Am Acad Dermatol* 1995; 33:497-503.
22. Kligman AM. The compatibility of combinations of glycolic acid and tretinoin in acne and in photoaged skin. *J Geriatr Dermatol* 1995; 3(suppl A):25A-28A.
23. Lavker RM, Kaidby K, Leyden J. Effects of topical ammonium lactate on cutaneous atrophy from a potent topical corticosteroid. *J Am Acad Dermatol* 1992; 26:535-544.
24. Griffin TD, Murphy GF, Sueki H, et al. Increased factor XIIIa transglutaminase expression in dermal dendrocytes after treatment with  $\alpha$ -hydroxy acids. Potential physiologic significance. *J Am Acad Dermatol* 1996; 34:196-203.
25. Yardley HJ, Summerly R. Lipid composition and metabolism in normal and diseased epidermis. *Pharmacol Ther* 1981; 13:357-383.
26. Madison KC. Barrier function of the skin: "La raison d'être" of the epidermis. *Prog Dermatol* 2000; 34:1-12.
27. Rawlings AV, Scott IR, Harding CR, et al. Stratum corneum moisturization at the molecular level. *Prog Dermatol* 1994; 28:1-12.
28. Williams ML. Lipids in normal and pathological desquamation. In: Elias PM, ed. *Advances in Lipid Research*. New York: Academic Press, 1991:211-262.
29. Shapiro LJ, Weiss R, Webster D, et al. X-Linked ichthyosis due to steroid sulphatase deficiency. *Lancet* 1978; 1:70-72.
30. Dahl MV, Dahl AC. 12% Lactate lotion for the treatment of xerosis. *Arch Dermatol* 1983; 119:27-30.
31. Berardesca E, Distane F, Vignoli GP, et al. Alpha hydroxyacids modulate stratum corneum barrier function. *Br J Dermatol* 1997; 137:934-938.
32. Briden ME, Cacatua LS, Patriots MA, et al. Treatment of acne with glycolic acid. *J Geriatr Dermatol* 1996; 4:22B-27B.
33. Atzori L, Brundu MA, Biggio AOP. Glycolic acid peeling in the treatment of acne. *J Eur Acad Dermatol Venereol* 1999; 12: 119-122.
34. Bernstein EF, Green BA, Edison B, et al. Polyhydroxy acids (PHAs). Clinical uses for the next generation of hydroxy acids. *Skin Aging* 2001; Sept Suppl:4-11.
35. Kligman AM, Kligman LH. Photoaging. In: Fitzpatrick TB, Eisen AZ, Wolff K, et al., eds. *Dermatology in General Medicine*. Volume 2. New York: McGraw-Hill, 1993:2972-2979.
36. Gilchrist BA. Overview of skin aging. *J Cutan Aging Cosmet Dermatol* 1988; 1:1-3.
37. Uitto J, Fazio MJ, Olsen DR. Cutaneous aging. Molecular alterations in elastic fibers. *J Cutan Aging Cosmet Dermatol* 1988; 1:13-26.

38. Yaar M, Gilchrist BA. Aging of skin. In: Freedberg IM, Eisen AZ, Wolff K, et al., eds. *Dermatology in General Medicine*. 5th ed. New York: McGraw-Hill, 1999:1697–1706.
39. Green BA, Edison BL, Wildnauer RH, et al. Lactobionic acid and gluconolactone. PHAs for photoaged skin. *Cosmet Dermatol* 2001; 9:24–28.
40. Bergfeld W, Tung R, Vidimos A, et al. Improving the cosmetic appearance of photoaged skin with glycolic acid. *J Am Acad Dermatol* 1997; 36:1011–1013.
41. Bernstein EF, Uitto J. Connective tissue alterations in photodamaged skin and the effects of alpha hydroxy acids. *J Geriatr Dermatol* 1995; 3(suppl A):7A–18A.
42. Rendon MI, Okan G. The use of alpha hydroxy acids in xerosis and photoaging. In: Moy R, Luftman D, Kakita L, eds. *Glycolic Acid Peels*. New York: Marcel Dekker, 2002:115–139.
43. McGregor JM, Hawk JL. Acute effects of ultraviolet radiation on the skin. In: Freedberg IM, Eisen AZ, Wolff K, et al., eds. *Dermatology in General Medicine*. 5th ed. New York: McGraw-Hill, 1999:1555–1561.
44. KGL Protocol Final Reports #3929, #3813, #3800: an investigation of the short-term effects of topical treatments on the sensitivity of human skin to UVR. Pennsylvania: KGL Inc., 1996.
45. Johnson AW, Kligman AM. Application of 4% and 8% glycolic acid to human skin in commercial skin creams formulated to CIR guidelines does not thin the stratum corneum or increase sensitivity to UVR. *J Cosmet Sci* 2000; 51:343–349.
46. Green BA, Wildnauer RH, Edison BL. Polyhydroxy acids (PHAs) provide conditioning effects to skin without increasing sensitivity to UV light. *Am Acad Dermatol Poster Exhibit No. 74*, New Orleans, LA, February 22–27, 2002.
47. Moy LS, Murad H, Moy RL. Glycolic acid peels for the treatment of wrinkles and photoaging. *J Dermatol Surg Oncol* 1993; 19: 243–246.
48. Pinnell SR. Cutaneous photodamage, oxidative stress, and topical antioxidant protection. *J Am Acad Dermatol* 2003; 48:1–19.
49. Thiele JJ, Schroeter C, Hsieh SN, et al. The antioxidant network of the stratum corneum. In: Thiele J, Elsner P, eds. *Oxidants and Antioxidants in Cutaneous Biology*. Basel: Karger, 2001:26–42.
50. Dreher F, Maibach H. Protective effects of topical antioxidants in humans. In: Thiele J, Elsner P, eds. *Oxidants and Antioxidants in Cutaneous Biology*. Basel: Karger, 2001:157–164.
51. Meister A. *Biochemistry of the Amino Acids*. 2nd ed. New York: Academic Press, 1965:690, 444–445.
52. Granner DK. Pituitary and hypothalamic hormones. In: Murray RK, Granner DK, Mayes PA, et al., eds. *Harper's Biochemistry*. 25th ed. Stamford: Appleton & Lange, 2000:550–560.
53. Murray RK, Keeley FW. The extracellular matrix. In: Murray RK, Granner DK, Mayes PA, et al., eds. *Harper's Illustrated Biochemistry*. 26th ed. New York: McGraw-Hill, 2003:535–555.
54. Aruoma OI, Halliwell B, Hoey BM, et al. The antioxidant action of N-acetylcysteine: its reaction with hydrogen peroxide, hydroxyl radical, superoxide, and hypochlorous acid. *Free Radic Biol Med* 1989; 6:593–597.
55. *The Merck Index*. 13th ed. Whitehouse Station: Merck & Co., Inc., 2001:803–804.



## Retinyl propionate and related retinoids

John E. Oblong

### INTRODUCTION

Retinoids represent a class of lipophilic compounds that are composed of natural derivatives of vitamin A (retinol) as well as synthetic analogues. Naturally occurring retinoids are sourced via dietary intake of  $\beta$ -carotene as well as retinyl esters, both of which are found in a broad range of foodstuffs and animal by-products. Structurally,  $\beta$ -carotene exists essentially as a dimer form of retinol, and the enzymatic conversion in the intestinal tract via retinal production is the initial sourcing of retinoids for usage by the human body. Most eukaryotic cells have the capability of enzymatically converting retinol and retinyl esters to various metabolites that are critical in maintaining cellular homeostasis, regulating proliferation and differentiation patterns, as well as embryonic development. Of the metabolites generated, the true “business end” of retinoids is retinoic acid, which is present in cells as various *cis* conformations as well as *trans*-retinoic acid (tRA). Since retinoids play such a critical role in developmental biology, the metabolic pathways are tightly regulated. This includes not only enzymatic processes but transport via cellular retinoid-binding proteins as well.

Topical usage of potent forms of natural and synthetic retinoids such as tRA has shown a high degree of efficacy against acne, psoriasis, ichthyosis, and actinic keratosis. Relative to photodamaged skin, tRA has clearly been established as having a robust effect (1,2) and is currently marketed as a prescription drug. These retinoid effects in diseased skin can be ascribed on some level as being a normalization of altered skin conditions. However, two of the key negatives associated with highly potent topical retinoids are irritation that, in some instances, does not mitigate itself completely even after long-term chronic exposure and teratogenic side effects.

Less potent topical retinoids such as retinol and various retinyl esters (Fig. 11.1) have been building a rich history of usage in the cosmetic marketplace. More importantly for the cosmetic marketplace is the ability of retinoids to positively impact changes in the appearance of photodamaged facial skin, particularly for fine lines, wrinkles, as well as pigmentation-related changes. Additionally, understanding the basic biochemical metabolic processes that control endogenous retinoid levels and synthesis has shown that cosmetic-type retinoids present an attractive compromise for less serious conditions such as photodamaged skin. This chapter will focus on cutaneously delivered retinyl esters, and the topics covered will include an overview of the metabolism, biochemistry, and molecular biology as well as human study findings. Additionally, the principle focus in terms of treatment effects will be on photodamaged skin.

### BIOCHEMISTRY AND MOLECULAR BIOLOGY OF TOPICAL RETINOL AND RETINYL ESTERS

Of most relevance to the cosmetic industry was the confirmation that cosmetic forms of retinoids have the potential to be enzymatically converted to various retinoid metabolites including tRA when topically administered (3–8). The biochemical conversions are shown schematically in Figure 11.2A where retinol is oxidized via small-chain alcohol dehydrogenases to retinal and in turn to form tRA (5,9). This process is begun when free retinol associates with a specific cytoplasmic retinol-binding protein (CRBP). This family of proteins with high retinoid specificity includes CRBP as well as retinoic acid-binding protein of which there are two isoforms, I and II (7). These binding proteins play a direct role in regulation of retinoid responses in cells by acting as chaperones in enzymatic conversions, sequestration, and stabilization. The retinol-CRBP complex is a substrate for retinol dehydrogenase, a microsomal enzyme uniquely capable of catalyzing the conversion of retinol to retinaldehyde. Retinaldehyde is then rapidly and quantitatively oxidized to retinoic acid by retinaldehyde oxidase (5,10). However, the primary reaction that occurs with CRBP-bound retinol is esterification of retinol via lecithin:retinol acyltransferase or acyl CoA:retinol acyltransferase (ARAT) to retinyl esters, the primary storage form in lipid bilayers and of which retinyl palmitate is the major species in human skin (11,12). Recent work has identified the neutral lipid synthesis enzyme acyl-CoA:diacylglycerol acyltransferase 1 as a novel ARAT enzyme present in murine skin that regulates retinol oxidation to retinoic acid (13). Additionally, retinyl stearate has been identified as the major form that is present in circulating serum in mammalian systems (14). This multistep processing of retinyl esters serves as a point of regulation to control the level of active retinoid in the skin and may thus contribute to the lower irritation potential of these derivatives.

The molecular mechanistic route that tRA follows in skin is via its function as an agonist for binding to a family of nuclear receptors called the retinoic acid receptors (RAR) and which also includes the retinoid X receptors (RXR). In each of these two families, three isoforms exist and interact to form heterodimers as the functionally active form. Significant research has gone into understanding these various dimer combinations, including agonist binding as related to various tissues and cells. Upon binding of tRA by RAR and dimerization with a member of RXR, this active complex becomes a transcriptional regulator that binds to select sequences in promoter regions of select genes, termed retinoic acid responsive elements or RAREs (15).

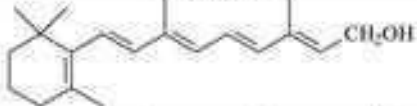
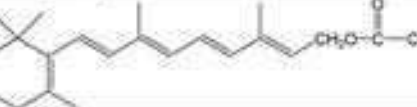
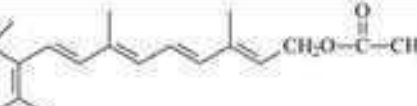
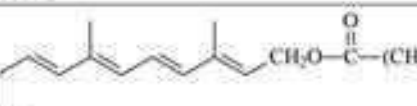
Retinoid	Structure
retinol	
retinyl acetate	
retinyl propionate	
retinyl palmitate	

Figure 11.1 Chemical structures of retinol and retinyl esters.

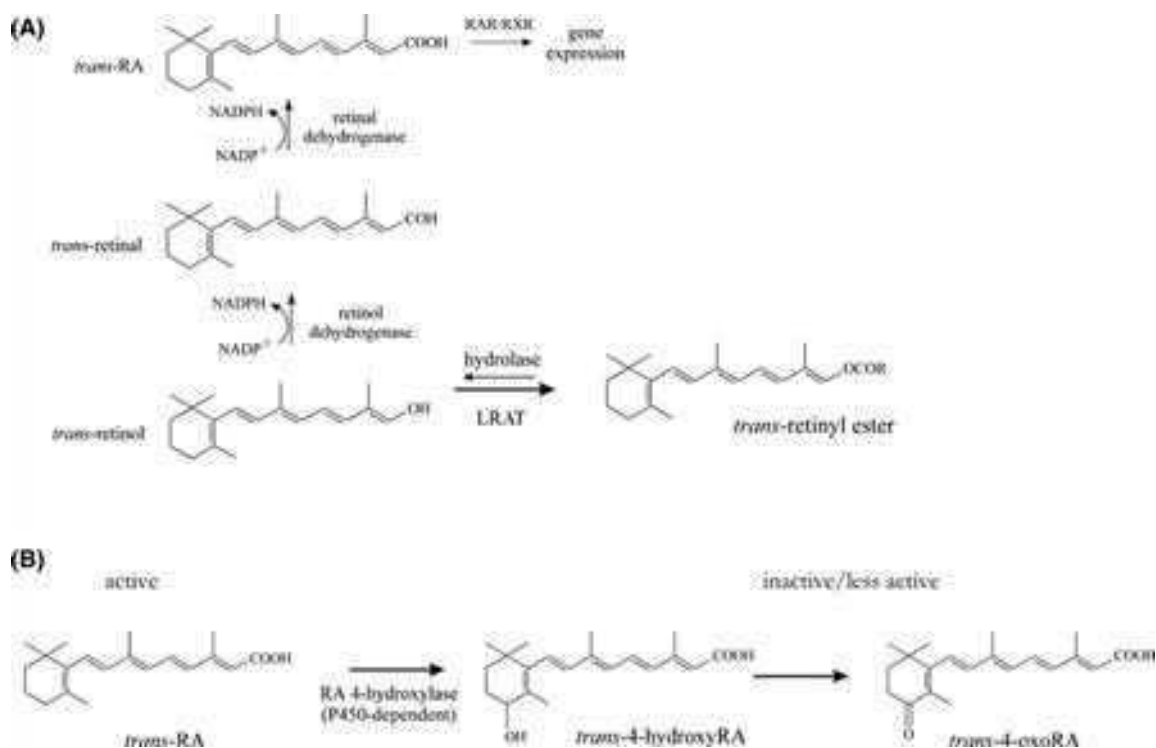


Figure 11.2 Retinoid metabolic pathways in skin.

As with most biological processes that involve highly potent agents, the retinoid pathway has several regulatory feedback loops that help maintain an optimal level of tRA. One of the most important ones is depicted in Figure 11.2B, which shows the degradation of tRA to the less active metabolites via hydroxylation to 4-hydroxy-retinoic acid and 4-oxo-retinoic acid,

catalyzed by members of the CYP26 family (16). As tRA levels become temporarily elevated, increased hydroxylase activity via higher expression levels leads to a decrease to steady state levels.

In summary, the biochemical confirmation that topical retinol and retinyl esters can be metabolized to the more active form of tRA in skin cells has provided a richer understanding

**Table 11.1** Changes in Epidermal and Granular Layer Thicknesses in Forearm Skin Due To Retinoid Treatment

Topical treatment	Code	Epidermal thickness ( $\mu\text{m}$ )	Significance vs. control and other treatments <sup>a</sup>	Granular layer thickness ( $\mu\text{m}$ )	Significance vs. control and other treatments <sup>a</sup>
Emulsion control	A	50.75	–	3.03	–
1.0% Retinyl palmitate	B	52.07	Ns	4.88	ns
0.172% Retinyl acetate	C	65.45	ABGHI	10.73	ABH
0.30% Retinyl acetate	D	79.00	ABCeF	12.34	ABH
0.18% Retinyl propionate	E	68.83	ABGHI	10.61	ABH
0.30% Retinyl propionate	F	64.87	ABGHI	10.73	ABH
0.075% Retinol	G	80.13	ABCEF	14.06	AB
0.15% Retinol	H	85.66	ABCEF	17.44	ABCDEF
0.025% <i>trans</i> -Retinoic acid	I	80.64	ABCEF	14.72	AB

<sup>a</sup>Upper case letters denote significant differences ( $p < 0.05$ ), while lower case letters denote directional differences ( $p < 0.10$ ). ns = not significant.

of how cosmetic retinoids are capable of having subtle effects on photodamaged skin. As we begin to understand deeper the molecular biology changes that are caused via tRA binding to RAR/RXR, novel mechanistic insights into the efficacy as well as the negative irritation side effects could allow for an improvement in current commercialized products.

### POTENTIAL TO BREAK THE RETINOID EFFICACY TO IRRITATION CORRELATION WITH RETINYL ESTERS

Over the past few decades, retinol has been used extensively in cosmetic products with the levels of retinol ranging from barely detectable to upwards of 0.5%. The relative dosage levels vary in part because of intolerance among consumers of irritation side effects that is connected in part by a sensitivity to formulation differences. As highlighted earlier, it has been generally assumed that any efficacy from topically delivered retinol occurs via its sequential conversion via the intermediate retinal to tRA (8). For example, it has been shown that 0.4% retinol can significantly improve the appearance of wrinkles on the surface of skin but also have measured histological changes in the extracellular matrix components of epidermal glycosaminoglycans and dermal collagen type I (17). The authors also speculated that retinol-treated skin would be more resistant to future skin injury, including ulcer formation among elderly consumers. These reported effects are hallmark responses associated with topical tRA.

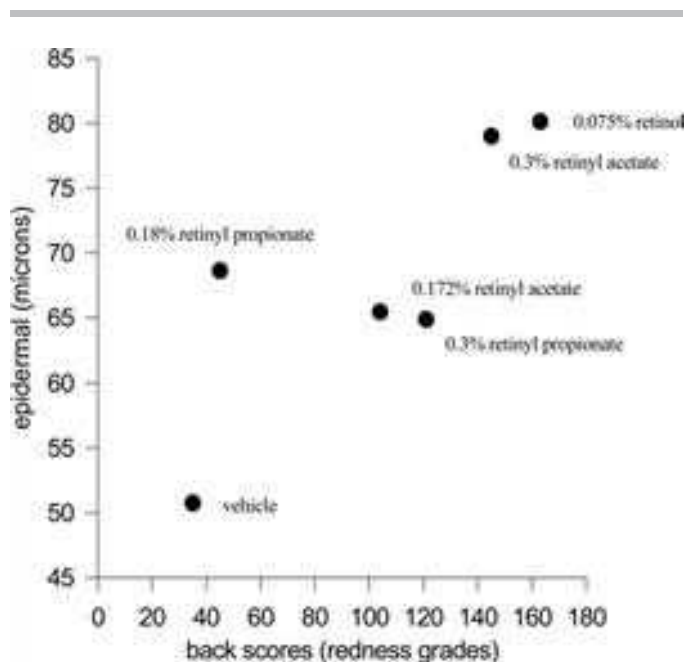
Several natural and synthetic esters of retinol have been evaluated for retinoid-like effects, including acetate, propionate, palmitate, ascorbate,  $\beta$ -glucuronide, and retinyl *N*-formyl aspartamate. Although the chemical structure of retinol is conducive to being esterified via the alcohol group, the ability for retinyl esters to deliver efficacy that approaches retinol becomes limited by variables such as skin penetration, cellular uptake, hydrolase active site binding, re-esterification via acyl transferases, and general pharmacokinetics. As with most retinoid analogue work, the objective of evaluating retinyl esters is to be able to provide a retinoid-like response on facial skin but without the negatives of irritation associated with topical usage.

Since retinyl esters are dependent on an additional biochemical processing step before releasing a free form of retinol (Fig. 11.2A), it is anticipated that topical retinyl esters would have a weaker retinoid responsiveness range when compared with retinol. A human forearm biopsy study was performed that evaluated via histology the effect of tRA, retinol, and three

retinyl esters (acetate, propionate, and palmitate) for the effects on changes in epidermal and granular layer thickness compared to a placebo control (Table 11.1). Both retinyl acetate and retinyl propionate were able to show a significant increase in both thickness measures as compared to the placebo control. The results with retinyl propionate are similar to what has been previously reported (18). These results also highlight that there is a relative rank ordering based on the biochemical processing steps among the retinoids tested. In comparing the retinyl esters, there also appears a ranking in terms of chain length from shortest to longest, with shorter chained esters being more potent than longer chained esters. Although less intuitive, the potential that shorter chained retinyl esters can be acted on by other esterases could partially explain their enhanced retinoid response profile compared with retinyl palmitate, the endogenous storage form. Since the experimental data in the table was performed under semiocclusive patch, the ability of the retinoids to penetrate into the viable cell layers is lessened as a variable for this comparison but may not explain the complete story for retinyl palmitate (19).

As would be suspected, this rank ordering of retinoid-based activity (efficacy) is also indirectly proportional to the level of irritation that some topical retinoids can induce on skin (19; Oblong, unpublished data). A comparison of human retinoid activity data from Table 11.1 with irritation data from a human back cumulative irritation protocol using nearly identical formulations shows that there is a general correlation among the esters and retinol between retinoid activity and irritation with the one exception of retinyl propionate at 0.18% levels (Fig. 11.3). This supports in-house clinical findings that retinyl propionate does not cause as much irritation as retinol and still is able to positively impact the appearance of fine lines and wrinkles in 12-week human facial studies (20). Although additional data would be required around the doses tested to confirm, these results support the suggestion that retinyl propionate is capable of eliciting a retinoid response in human skin but with a weaker overall retinoid irritation profile.

In terms of application to photodamaged skin, retinyl propionate has recently become of interest since it is capable of affecting human skin much like retinol but with a lower irritation profile than other retinoids (20,21; Fig. 11.3). While the relative activity of retinyl propionate on photodamaged skin is weaker than retinol (22), it is clear that some of the effects are still significant (20,21). This combination of significant efficacy with an overall lower irritation profile has been noted in cross comparison of human biopsy studies, back cumulative irritation, and human facial skin clinicals (20). Although less critical



**Figure 11.3** Correlation between human irritation measures and epidermal thickening for retinyl acetate, retinyl propionate, and retinol.

than its overall efficacy and irritation profile, retinyl propionate has been reported to have a better chemical stability profile compared to other esters, thereby increasing half-life on skin during topical delivery (23).

The more potent ester retinyl acetate has been shown in *in vivo* models as being able to induce a retinoid-like response as measured by epidermal thickening as well as indirect markers of epidermal proliferation (24). Additionally, the kinetics of the accommodation response to retinyl acetate as measured by erythema has a similar time curve over a 20-day period as has been observed in human studies for accommodation response to retinol (Oblong, unpublished results). Since retinyl acetate has a similar pharmacactivity and irritation profile as retinol, there appears to be no advantage of this ester over retinol in cosmetic products.

Of the retinyl esters currently practiced in the cosmetic marketplace, retinyl palmitate appears to be one of the weaker retinoids in terms of efficacy for generating a retinoid response in human skin, including effects on photodamaged skin. This is more than likely due to the primary storage role of endogenous retinyl palmitate, which is a key regulatory point. Although some level of topically applied retinyl palmitate can be converted to retinol, the small amount of retinyl palmitate that actually penetrates the skin would be expected to become accumulated into endogenous storage pools (4). On the basis of published information and historical cosmetic usage, it is accepted that retinyl palmitate has at best an overall weak activity profile and is nonirritating (19). As shown in Table 11.1, evaluation of epidermal and granular layer thickening has also shown the weak retinoid effect in human biopsy studies.

Finally, it has been observed that there may be a plateau of responsiveness among retinyl esters as observed in various retinoid-sensitive models (Oblong, unpublished data). This

suggests a threshold level in which excess retinol derived from shorter chain retinyl esters could be competitively targeted by acyl transferases over retinol dehydrogenases and incorporated into retinyl palmitate storage pools. Thus, the ability to deliver greater efficacy from retinyl esters in general may become dependent more on optimal R-groups or combination therapies rather than attempting to elevate the topical dose used. Examples include the published clinical findings that showed the photostable ester retinyl *N*-formyl aspartamate was able to deliver retinoid-like effects on photodamaged skin without significant irritation (25).

## SUMMARY

Retinoids are a broad family of molecules that can be metabolized via endogenous enzymatic pathways to generate agonists for members of the RAR and RXR nuclear receptor family. In turn, this denotes their critical role in regulating gene expression profiles via RAR/RXR binding to RAREs. In dermatology, prescription forms of natural and synthetic retinoids have been shown to have beneficial effects on acne, psoriasis, ichthyosis, actinic keratosis, and photodamaged/aging skin attributes. Relative to photodamaged skin, the cosmetic industry has been using retinol and various retinyl esters for several decades. While the overall efficacy provided by these cosmetic forms of retinoid are generally less potent than the prescription forms such as tRA, the knowledge that these forms can be metabolized to more active forms supports the indirect mechanism of action that they utilize. Of the retinyl esters currently practiced in the marketplace, there appears to be advantages for the usage of retinyl propionate over retinyl acetate in terms of having a similar efficacy response range but with an improved irritation profile. In contrast, retinyl palmitate has a very low efficacy response range, rendering its low irritation profile as moot in terms of being able to have any positive benefits for affecting the appearance photodamaged skin.

Future research in better understanding the connections between efficacy and retinoid-induced irritation should allow for the identification of novel retinyl ester that decouple these two phenomena. The results presented with retinyl propionate suggest the potential exists. Additionally, there would appear to be an opportunity to identify a final solution that combines optimized levels, formulations, and potentially additional materials to maintain or elevate retinoid-like efficacy but with a reduced overall irritation profile.

## REFERENCES

1. Kligman AM, Grove GL, Hirose R, et al. Topical tretinoin for photoaged skin. *J Am Acad Dermatol* 1986; 15:836-859.
2. Weiss JS, Ellis CN, Headington JT, et al. Topical tretinoin improves photoaged skin. A double-blind vehicle-controlled study. *J Am Med Assoc* 1988; 259:527-532.
3. Harrison EH. Enzymes catalyzing the hydrolysis of retinyl esters. *Biochim Biophys Acta* 1993; 1170:99-108.
4. Boehnlein J, Sakr A, Lichtin JL, et al. Characterization of esterase and alcohol dehydrogenase activity in skin. Metabolism of retinyl palmitate to retinol (vitamin A) during percutaneous absorption. *Pharm Res* 11:1155-1159.
5. Kang S, Duell EA, Fisher GJ, et al. Application of retinol to human skin *in vivo* induces epidermal hyperplasia and cellular retinoid binding proteins characteristic of retinoic acid but without measurable retinoic acid levels of irritation. *J Invest Dermatol* 1995; 105:549-556.

6. Kurlandsky SB, Xiao J-H, Duell EA, et al. Biological activity of all-trans retinol requires metabolic conversion to all-trans retinoic acid and is mediated through activation of nuclear retinoid receptors in human keratinocytes. *J Biol Chem* 1994; 269:32821–32827.
7. Bailly J, Crettaz M, Schifflers MH, et al. In vitro metabolism by human skin and fibroblasts of retinol, retinal and retinoic acid. *Exp Dermatol* 1998; 7:27–34.
8. Antille C, Tran C, Sorg O, et al. Penetration and metabolism of topical retinoids in ex vivo organ-cultured full-thickness human skin explants. *Skin Pharmacol Physiol* 2004; 17:124–128.
9. Napoli JL. Retinol metabolism in LLC-PK1 cells. Characterization of retinoic acid synthesis by an established mammalian cell line. *J Biol Chem* 1986; 261:13592–13597.
10. Kurlandsky SB, Duell EA, Kang S, et al. Auto-regulation of retinoic acid biosynthesis through regulation of retinol esterification in human keratinocytes. *J Biol Chem* 1996; 271:15346–15352.
11. Blomhoff R, Green MH, Norum KR. Vitamin A: physiological and biochemical processing. *Ann Rev Nutr* 1992; 12:37.
12. Got L, Gousson T, Delacoux E. Simultaneous determination of retinyl esters and retinol in human livers by reversed-phase high-performance liquid chromatography. *J Chromatogr B Biomed Appl* 1995; 668:233–239.
13. Shih MY, Kane MA, Zhou P, et al. Retinol esterification by DGAT1 is essential for retinoid homeostasis in murine skin. *J Biol Chem* 2009; 284:4292–4299.
14. Ribaya-Mercado JD, Blanco MC, Fox JG, et al. High concentrations of vitamin A esters circulate primarily as retinyl stearate and are stored primarily as retinyl palmitate in ferret tissues. *J Am Coll Nutr* 1994; 13:83–86.
15. Vasios GW, Gold JD, Petkovich M, et al. A retinoic acid-responsive element is present in the 5' flanking region of the laminin B1 gene. *Proc Natl Acad Sci U S A* 1989; 86:9099–9103.
16. Heise R, Mey J, Neis MM, et al. Skin retinoid concentrations are modulated by CYP26A1 expression restricted to basal keratinocytes in normal human skin and differentiated 3D skin models. *J Invest Dermatol* 2006; 126:2473–2480.
17. Kafi R, Kwak HS, Schumacher WE, et al. Improvement of naturally aged skin with vitamin A (retinol). *Arch Dermatol* 2007; 143: 606–612.
18. Ridge BD, Batt MD, Palmer HE, et al. The dansyl chloride technique for stratum corneum renewal as an indicator of changes in epidermal mitotic activity following topical treatment. *Br J Dermatol* 1988; 118:167–174.
19. Duell EA, Kang S, Voorhees JJ. Unoccluded retinol penetrates human skin in vivo more effectively than unoccluded retinyl palmitate or retinoic acid. *J Invest Dermatol* 1997; 109:301–305.
20. Oblong JE, Saud A, Bissett DL, et al. Topical retinyl propionate achieves skin benefits with favorable irritation profile. In: Elsner P, Maibach HI, eds. *Cosmeceuticals and Active Cosmetics: Drugs Versus Cosmetics (Cosmetic Science and Technology Series)*. Informa Healthcare, New York 2005:441–464.
21. Oblong JE, Bissett DL. Retinoids. In: Draeos Z, ed. *Cosmeceuticals (Procedures in Cosmetic Dermatology)*. Philadelphia: Elsevier Saunders, 2005:35–42.
22. Green C, Orchard G, Cerio R, et al. A clinicopathological study of the effects of topical retinyl propionate cream in skin photoageing. *Clin Exp Dermatol* 1998; 23:162–167.
23. Semenzato A, Bovenga L, Faiferri L, et al. Stability of vitamin A propionate in cosmetic formulations. *SÖFW J* 1997; 123:151–154.
24. Jarrett A, Wrench R, Mahmoud B. The effects of retinyl acetate on epidermal proliferation and differentiation. Induced enzyme reactions in the epidermis. *Clin Exp Dermatol* 1978; 3:173–188.
25. Lee MS, Lee KH, Sin HS, et al. A newly synthesized photostable retinol derivative (retinyl N-formyl aspartamate) for photodamaged skin: profilometric evaluation of 24-week study. *J Am Acad Dermatol* 2006; 55:220–224. [Epub June 5, 2006].

## Idebenone (hydroxydecyl ubiquinone)

Birgit A. Neudecker, Falko Diedrich, and Howard I. Maibach

### INTRODUCTION

Idebenone is a unique new antioxidant in dermatology used to treat the visible and cellular signs of skin aging. This chapter reviews the description, uses, functionality, cell biological and clinical research, safety and recent new improvements of this respiratory chain analog of coenzyme Q10.

### DESCRIPTION

Idebenone is a bioengineered analog, but not a derivative of ubiquinone (coenzyme Q10). It belongs in the family of molecules known as quinones, in particular it is a 1,4-benzoquinone molecule, as is hydroquinone. Its molecular weight is 338, compared with coenzyme Q10 with a molecular weight of 860, and therefore, in theory has much greater skin penetration potential. Idebenone is a potent antioxidant, with the ability to operate under low oxygen tension situations, and not showing prooxidative metabolites (1,2). Because of its ability to inhibit lipid peroxidation, idebenone protects cell membranes and mitochondria from oxidative damage caused by free radicals generated during cell metabolism, processes which are also summarized as intrinsic aging (2–4). Ultraviolet radiation (UVR)-generated reactive oxygen species (ROS) play a critical role in the process of photocarcinogenesis and environmentally induced aging, also termed as photoaging or extrinsic aging (5–9). Recent studies claim that also infrared radiation and visible light contribute to a major extend to such kind of damage (10,11). Although the skin possesses a complex antioxidant network, both intrinsic and extrinsic pathways can provoke an imbalance of the fragile prooxidant-antioxidant equilibrium (12–17) eventually leading to alteration of cells and structural macromolecules of the dermal connective tissue with its clinical appearance of wrinkle formation, laxity and pigment disorders. In comparison with other antioxidants, idebenone shows *in vitro* studies as well as *in vivo* studies unique properties providing protection regarding both intrinsic and extrinsic processes of aging (18–20).

### HISTORY AND USES

Idebenone has a history in medical applications dating back to 1982 with its initial introduction in the scientific community in papers published by Shimamoto et al. (21–23) citing its potential applications in the energy metabolism of red blood cells and myocardial tissue. Additional research over the next few years lead to the first phase I study to determine the tolerance, safety and pharmacokinetics of idebenone (24) followed by clinical studies in the early 1990s in subjects with Alzheimer's disease (25,26). It has since been researched extensively for a variety of applications related to the treatment of various age

related disorders of the human body, including Cerebrovascular and Alzheimer's disease, Friedreich's ataxia and showed protective properties in organ preservation solutions (2). Until 2009 over 270 articles have been published, mostly related to the health benefits of idebenone as an antiaging modality (27–32). The potential benefits of idebenone fall into five categories: antiaging, energy enhancement, cognition enhancement, organ protection and protection against excitatory amino acid neurotoxicity. Its relatively recent introduction in the field of dermatology in 2003 as a compound purported to be beneficial in the treatment of many skin changes associated with acute and chronic skin aging.

As with other antioxidants, idebenone exists in a reduced and an oxidized state. In a study of its effect on astroglial cells, idebenone, in either redox state, significantly inhibited the enzymatic metabolism of arachidonic acid by cyclooxygenase and lipoxygenase. This effect was stronger with the reduced form, and showed potential central nervous system anti-inflammatory activity (27).

In another study synaptosomes isolated from rat brain cortex were treated with iron and ascorbate establishing experimental cellular oxidant injury. Idebenone prevented both, the formation of ROS in the cytosol and mitochondria, as well as a decrease in proteinsulphydryl content (an indicator of protein oxidation), compared with controls (28).

In addition to its function as an antioxidant, idebenone works as an electron carrier in the electron transfer chain, similar to coenzyme Q10. Idebenone was introduced into a canine coenzyme Q10-depleted brain mitochondrial preparation, which prevented the loss of electron chain transfer activity normally seen with coenzyme Q10 depletion (3).

Idebenone also inhibited mitochondrial lipid peroxidation (4), which can be interpreted as protecting against mitochondrial damage. Other animal studies confirm the mitochondrial membrane protective effects of idebenone (29,30).

### FUNCTIONALITY

According to the mitochondrial theory of aging, nonrepaired damage of mitochondrial DNA and unstable electron transfer cause an important loss of mitochondrial function in correlation with progression of age (6). Mitochondria are the sites of cellular metabolic energy production where oxygen is used to convert carbohydrates into ATP to power and enable all cellular metabolic activity. The process itself produces toxic free radicals as the result of electron transfer, which can result in cellular damage if uncontrolled (33,34). Therefore cells have developed defense mechanisms, including essential enzymes and coenzymes such as coenzyme Q10, SOD, and catalase that are capable to reduce radical by-products of cellular energy

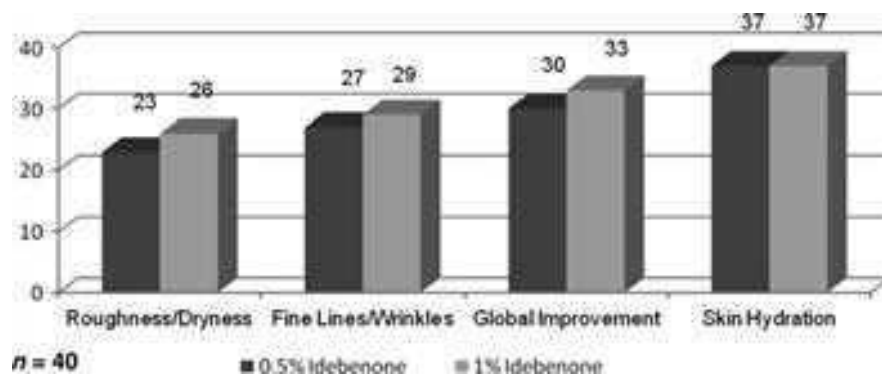


Figure 12.1 Percent increase/decrease after six-week use.

production eventually into water (12,35). Unfortunately, these defense mechanisms are efficient only to a certain degree and liberated free radicals such as superoxide radicals can react with cellular organelles and molecules as, for example, DNA, lipids, sugars and proteins to cause cellular damage, which expresses itself as aging (6,8,9,12). Mitochondria possess the ability to replicate containing their own DNA but have far less repair mechanisms than nuclear DNA despite the fact that they are the sites where most internal free radicals are formed. The result is cellular aging directly associated with metabolic energy production (33). For this reason, mitochondria require potent free radical scavenging antioxidants to prevent the early onset of cellular aging. Coenzyme Q10 protects mitochondria from oxidant decay. As mentioned above, the function of idebenone as an electron transfer respiratory chain antioxidant is closely related to that of coenzyme Q10, which itself is a vital biochemical found in cellular and mitochondrial membranes and plays a critical role in the electron transport chain during the production of energy in the mitochondria. However, unlike coenzyme Q10, idebenone lacks the potential downside of a degradative prooxidative effect, especially under hypoxic cellular conditions, such as those found after stroke, heart attack, excessive exercise or other conditions that lead to poor tissue oxygenation. Idebenone appears to be able to tightly couple oxygen to the electron transport chain and thus prevent toxic oxygen radical production far more superior than coenzyme Q10 (3).

## DERMATOLOGY: CELL BIOLOGICAL AND CLINICAL RESEARCH

It is important not to confuse idebenone with other commonly used antioxidants in skincare such as vitamin antioxidants like vitamin C and vitamin E or botanical antioxidants such as polyphenols, flavonoids and proanthocyanidins. Idebenone differs from these other types of antioxidants in that it is a respiratory chain antioxidant that targets aging at the mitochondria. In 2003 and 2005, the first cell biological in vitro and in vivo clinical studies were published (18–20) that demonstrated that idebenone had a potent ability to protect cellular lipids, cell membranes and DNA from oxidative stress and prevent sunburn cell (SBC) formation post ultraviolet (UV) exposure, and thus could have a significant protective and

corrective effect on skin aging. In a multistep protocol, a series of five different cell biological in vitro and clinical in vivo methods were combined to compare the antioxidative capacities of the following antioxidants: vitamin C, vitamin E,  $\alpha$ -lipoic acid, coenzyme Q10, kinetin, and idebenone. The studies included measurement of the ability of the antioxidant to

1. scavenge free radicals produced in a reaction chamber using instrumental analysis (Photochem<sup>®</sup>),
2. protect against low-density lipoprotein (LDL) oxidation as a marker of lipid peroxidation,
3. protect against cell membrane oxidation,
4. protect against DNA cross linking post UV exposure, and
5. protect human skin from SBC formation post UV exposure.

In a scoring system, which was based on a maximum score of 100, idebenone was found to be the most efficient antioxidant tested at the time.

Since that time idebenone has been researched in further clinical studies measuring the effects at various concentrations to reduce the overall appearance of fine lines, wrinkles, hyperpigmentation and other skin changes associated with photodamage and global skin aging. The results of these studies (unpublished) are outlined below:

40 subjects, six weeks, b.i.d., double blind, global assessment of 0.5% (20 subjects) and 1.0% (20 subjects) idebenone in the treatment of photodamaged skin with measurements for skin roughness/dryness, fine lines/wrinkles, skin hydration and global assessment by expert dermatologist grader. The results are given in Figure 12.1. In this study, punch biopsies of several patients were taken and stained for collagen 1, MMP-1, IL-1, and IL-6. The results demonstrated that idebenone was able to suppress formation of MMP, IL-1, IL-6, and increase deposition of collagen.

Recently, low concentrations of idebenone have been shown to upregulate certain important genes to suppress MMPs and interleukins and increase expression of certain structural proteins for collagen (personal communication with Dr D. McDaniel). Additionally, lifespan extension studies using *Drosophila* have demonstrated the ability of idebenone to extend lifespan of fruit flies under oxidative stress conditions (36). Similar results were found in knockout mouse models of Friedreich ataxia (37).

## SAFETY

As previously reviewed, sufficient preclinical and clinical data is available to demonstrate both cell biological and clinical antiaging benefits of idebenone. Consultations with several companies that market idebenone in topical skincare formulations also indicate that premarket safety HIRPT studies did not indicate any skin sensitivity concerns. However, post market surveillance (there are various formulations that have been on the market since 2004 including PreVage MD, PreVage, and PRIORI) suggests that there have been a few reported cases of skin sensitivity to the molecule, in most cases immediate and cumulative irritation reactions that can include skin redness, itching, and folliculitis, but in more severe cases, what appear to be classic allergic type reactions (38–40). Since the use of idebenone is new in skincare so it is in the general population, consumers reporting allergic type reactions on first use can only be explained via a cross sensitivity type model. Because the compound is a 1,4-benzoquinone, consumers who are exhibiting allergy to para-phenylenediamine, hydroquinone, evening primrose oil, and other similar compounds may exhibit the same sensitivity to idebenone. For this reason, products should carry a caution to “patch test” products with idebenone and to wait at least 24 hours prior to commencing regular use. If sensitivity occurs, consumers should not use products containing idebenone. It is worthy of notation here that there has never been a recorded allergic reaction to the internal consumption of idebenone in spite of its wide availability as a dietary supplement in many markets around the world.

## NEW IDEBENONE DERIVATIVE MOLECULES

Recent improvements in the topical skincare delivery of idebenone include the development of new synthetic molecular derivatives, which seem to have the capability to enhance efficacy and safety of this new antioxidant technology. Specifically, various water and oil soluble esters of idebenone were synthesized and tested for their ability to inhibit SBC formation post UV irradiation and the first clinical studies were conducted with assessments for known antiaging parameters including red and brown pigmentation, fine lines and wrinkles and global improvement in photodamage. Finally, skin maximization studies were conducted to assess skin tolerance. In these pilot studies the dipalmitic glyceric acid ester of idebenone (hydroxydecyl ubiquinoyl dipalmitoyl glycerate) was found to be the most efficient new idebenone derivative molecule across all test parameters (unpublished study, personal communication with Dr D. McDaniel).

It is believed that the improved antioxidant and antiaging efficiency of the new derivative is a result of increased skin and cell permeability, improved time released action of idebenone based on rate constant enzymatic hydrolysis in the skin, leading to broader skin compatibility and more efficient antioxidant capacity.

## CONCLUSION

Idebenone is a very promising new and unique respiratory chain antioxidant for topical skincare use in treating various signs of skin aging. In cell biological studies it has been shown to protect cellular lipoproteins, cell membranes and DNA from damage caused by oxidative stress. Clinically it has an anti-inflammatory effect, the ability to reduce SBCs post UV

exposure, and the ability to diminish the visible signs of skin aging including fine lines, wrinkles, hyperpigmentation, and overall improvement in photodamaged skin. Recent improvements in the technology have produced new idebenone derivative molecules, in particular, the dipalmitic glyceric acid, which seems to improve the delivery of the molecule and its efficacy but also significantly decreases the potential for skin sensitivity.

## REFERENCES

- Mordente A, Martorana GE, Minotti G, et al. Antioxidant properties of 2,3-dimethoxy-5-methyl-6-(10-hydroxydecyl)-1,4-benzoquinone (idebenone). *Chem Res Toxicol* 1998; 11(1):54–63.
- Wieland E, Schutz E, Armstrong VW, et al. Idebenone protects hepatic microsomes against oxygen radical-mediated damage in organ preservation solutions. *Transplantation* 1995; 15:60(5); 444–451.
- Imada I, Sato EF, Kira Y, et al. Effect of CoQ homologues on reactive oxygen generation by mitochondria. *Biofactors* 2008; 32(1–4):41–48.
- Imada I, Fujita T, Sugiyama Y, et al. Effects of idebenone and related compounds on respiratory activities of brain mitochondria, and on lipid peroxidation of their membranes. *Arch Gerontol Geriatr* 1989; 8(3):323–341.
- Berneburg MH, Plettenberg J, Krutmann J. Photoaging of human skin. *Photodermatol Photoimmunol Photomed* 2000; 16:239–244.
- Scharfetter-Kochanek K, Brenneisen P, Wenk J, et al. Photoaging of the skin from phenotype to mechanisms. *Exp Gerontol* 2000; 35:307–316.
- Berneburg M, Grether-Beck S, Kurten V, et al. Singlet oxygen mediates the UV-induced generation of the photoaging associated mitochondrial common deletion. *J Biol Chem* 1999; 274: 15345–15349.
- Gilchrest BA. A review of skin aging and its medical therapy. *Br J Dermatol* 1996; 135(6):867–875.
- Hadshiew IM, Eller MS, Gilchrest BA. Skin aging and photoaging: the role of DNA damage and repair. *Am J Contact Dermatol* 2000; 11:19–25.
- Schieke SM, Schroeder P, Krutmann J. Cutaneous effects of infrared radiation: from clinical observations to molecular response mechanisms. *Photodermatol Photoimmunol Photomed* 2003; 19(5):228–234.
- Cho S, Shin MH, Kim YK, et al. Effects of infrared radiation and heat on human skin aging in vivo. *J Investig Dermatol Symp Proc* 2009; 14(1):15–19.
- Thiele JJ, Schroeter C, Hsieh SN, et al. The antioxidant network of the stratum corneum. *Curr Probl Dermatol* 2001; 29:26–42.
- Podda M, Traber MG, Weber C, et al. UV-irradiation depletes antioxidants and causes oxidative damage in a model of human skin. *Free Radic Biol Med* 1998; 24(1):55–65.
- Wenk J, Brenneisen P, Meewes C, et al. UV-induced oxidative stress and photoaging. *Curr Probl Dermatol* 2001; 29:83–94.
- Darr D, Pinell SR. Reactive oxygen species and antioxidative protection in photodermatology. In: Lowe NJ, Shaath NA, Oathak MA, eds. *Sunscreens-Development, Evaluation, and Regulatory Aspects*. 2nd ed. New York: Marcel Dekker, Inc., 1997:155–173.
- Fuchs J, Packer L. *Oxidative Stress in Dermatology*. New York, Basel: Marcel Dekker, Inc., 1993:55–73.
- Sander CS, Chang H, Salzmann S, et al. Photoaging is associated with protein oxidation in human skin in vivo. *J Invest Dermatol* 2002; 118(4):618–625.
- Neudecker BA, Bekyarov D, Diedrich FK, et al. Antioxidants Compared in a Multiphasic Protocol to Measure to Measure Protective Capacity Against Oxidative Stress. Poster presentation American Academy of Dermatology, San Francisco, 2003.
- McDaniel DH, Neudecker BA, Dinardo JC, et al. Idebenone: a new antioxidant - part I. Relative assessment of oxidative stress



- protection capacity compared to commonly known antioxidants. *J Cosmet Dermatol* 2005; 4(1):10–17.
20. McDaniel D, Neudecker B, Dinardo J, et al. Clinical efficacy assessment in photodamaged skin of 0.5% and 1.0% idebenone. *J Cosmet Dermatol* 2005; 4(3):167–173.
  21. Shimamoto N, Goto N, Hirata M. Effects of 2,3-dimethoxy-5-methyl-6-(10'-hydroxydecyl)-1,4-benzoquinone (CV-2619) on the energy metabolism of red blood cells of rats. *Nippon Yakurigaku Zasshi* 1982; 80(2):137–145.
  22. Shimamoto N, Tanabe M, Imamoto T, et al. Effects of 2,3-dimethoxy-5-methyl-6-(10'-hydroxydecyl)-1,4-benzoquinone (CV-2619) on myocardial energy metabolism in the hypertrophied heart of spontaneously hypertensive rats. *Nippon Yakurigaku Zasshi* 1982; 80(4):299–306.
  23. Shimamoto N, Tanabe M, Hirata M. Effects of 2,3-dimethoxy-5-methyl-6-(10'-hydroxydecyl)-1,4-benzoquinone (CV-2619) on adriamycin-induced ECG abnormalities and myocardial energy metabolism in spontaneously hypertensive rats. *Nippon Yakurigaku Zasshi* 1982; 80(4):307–315.
  24. Barkworth MF, Dyde CJ, Johnson KI, et al. An early phase I study to determine the tolerance, safety and pharmacokinetics of idebenone following multiple oral doses. *Arzneimittelforschung* 1985; 35(11):1704–1707.
  25. Marigliano V, Abate G, Barbagallo-Sangiorgi G, et al. Randomized, double-blind, placebo controlled, multicentre study of idebenone in patients suffering from multi-infarct dementia. *Arch Gerontol Geriatr* 1992; 15(3):239–248.
  26. Senin U, Parnetti L, Barbagallo-Sangiorgi G, et al. Idebenone in senile dementia of Alzheimer type: a multicentre study. *Arch Gerontol Geriatr* 1992; 15(3):249–260.
  27. Civenni G, Bezzi P, Trotti D, et al. Inhibitory effect of the neuroprotective agent idebenone on arachidonic acid metabolism in astrocytes. *Eur J Pharm* 1999; 370:161–167.
  28. Cardoso SM, Pereira C, Oliveira CR. The protective effect of vitamin E, idebenone and reduced glutathione on free radical mediated injury in rat brain synaptosomes. *Biochem Biophys Res Commun* 1998; 246(3):703–710.
  29. Nagaoka A, Kakihana M, Fujiwara K. Effects of idebenone on neurological deficits following cerebrovascular lesions in stroke-prone spontaneously hypertensive rats. *Arch Gerontol Geriatr* 1989; 8(3):203–212.
  30. Nagaoka A, Suno M, Shibota M, et al. Effects of idebenone on neurological deficits, local cerebral blood flow, and energy metabolism in rats with experimental cerebral ischemia. *Arch Gerontol Geriatr* 1989; 8(3):193–202.
  31. Kakihana M, Yamazaki N, Nagaoka A. Effects of idebenone on the levels of acetylcholine, choline, free fatty acids, and energy metabolites in the brains of rats with cerebral ischemia. *Arch Gerontol Geriatr* 1989; 8(3):247–256.
  32. Kakihana M, Yamazaki N, Nagaoka A. Effects of idebenone (CV-2619) on the concentrations of acetylcholine and choline in various brain regions of rats with cerebral ischemia. *Jpn J Pharmacol* 1984; 36(3):357–363.
  33. Krutmann J, Schroeder P. Role of mitochondria in photoaging of human skin: the defective powerhouse model. *J Invest Dermatol Symp Proc* 2009; 14(1):44–49.
  34. Cardoso SM, Pereira C, Oliveira R. Mitochondrial function is differentially affected upon oxidative stress. *Free Radic Biol Med* 1999; 26(1–2):3–13.
  35. Shindo Y, Witte E, Han D, et al. Enzymatic and nonenzymatic antioxidants in epidermis and dermis of human skin. *J Invest Dermatol* 1994; 102:122–124.
  36. Seznec H, Simon D, Monassier L, et al. Idebenone delays the onset of cardiac functional alteration without correction of Fe-S enzymes deficit in a mouse model for Friedreich ataxia. *Hum Mol Genet* 2004; 13(10):1017–1024.
  37. Puccio H. Multicellular models of Friedreich ataxia. *J Neurol* 2009; 256(suppl 1):18–24.
  38. Mc Aleer MA, Collins P. Allergic contact dermatitis to hydroxydecyl ubiquinone (idebenone) following application of anti-ageing cosmetic cream. *Contact Dermatitis* 2008; 59(3):178–179.
  39. Natkunarajah J, Ostlere L. Allergic contact dermatitis to idebenone in an over-the-counter anti-ageing cream. *Contact Dermatitis* 2008; 58(4):239.
  40. Sasseville D, Moreau L, Al-Sowaidi M. Allergic contact dermatitis to idebenone used as an antioxidant in an anti-wrinkle cream. *Contact Dermatitis* 2007; 56(2):117–118.

# Antioxidants

Frank Dreher and Jens Thiele

## INTRODUCTION

As the outermost organ, the skin forms an efficient barrier against xenobiotics entering our body and protects from the harmful environment encompassing exposure to solar ultraviolet radiation (UVR) and air pollutants. Such an exposure results in the formation of reactive oxygen species (ROS) and other free radicals including reactive nitrogen species (RNS), which may subsequently react with several skin biomolecules. To counteract ROS and RNS induced oxidative stress, the skin is equipped with a variety of antioxidants forming an antioxidant network intervening at different levels of oxidative processes by scavenging and removing free radicals or oxidatively damaged biomolecules (1). However, the antioxidant defense in cutaneous tissues can be overwhelmed by an increased or prolonged exposure to exogenous sources of oxidative stress, which consequently leads to skin damage. Well documented solar UVR-induced skin damage includes acute reactions, such as erythema, edema, followed by exfoliation, tanning and epidermal thickening. Premature skin aging (photoaging) and photocarcinogenesis are the consequences of chronic UVR exposure.

Terrestrial solar UVR consists of UVB (290–320 nm) and UVA (UVA II: 320–340 nm, UVA I: 340–400 nm). Radiation less than 290 nm (UVC) does not reach the earth's surface, since these wavelengths are absorbed by stratospheric ozone. While ozone in the upper atmosphere occurs naturally and protects skin by filtering out harmful solar UVR, ozone at ground level (troposphere) is a noxious, highly reactive oxidant pollutant. Besides UVR and air pollutants such as tropospheric ozone, the presence of chemically unstable and ROS forming drugs as well as some exogenous photoreactive chemicals in skin may be other sources of cutaneous oxidative stress.

This chapter summarizes the currently available knowledge on mechanisms and sites of oxidative stress development in skin, its role in the formation of skin damage, and its prevention by strategies strengthening the skin's antioxidative defense capacity.

## REACTIVE OXYGEN SPECIES

Several steps lead to the formation of ROS during UVR exposure, which represents the best characterized source of oxidative stress in skin (2). The cascade of ROS formation is initiated by UVR absorption; predominantly in the UVA region, of endogenous or exogenous chromophores present in the skin. Of the many skin constituents capable of absorbing UVA, *trans*-urocanic acid, melanins, flavins, porphyrins, quinones, protein bound tryptophan or advanced glycation end products are believed to be relevant photosensitizers initiating the ROS formation cascade. Following UVR absorption, the activated chromophore may react in two ways. In type I photoreactions,

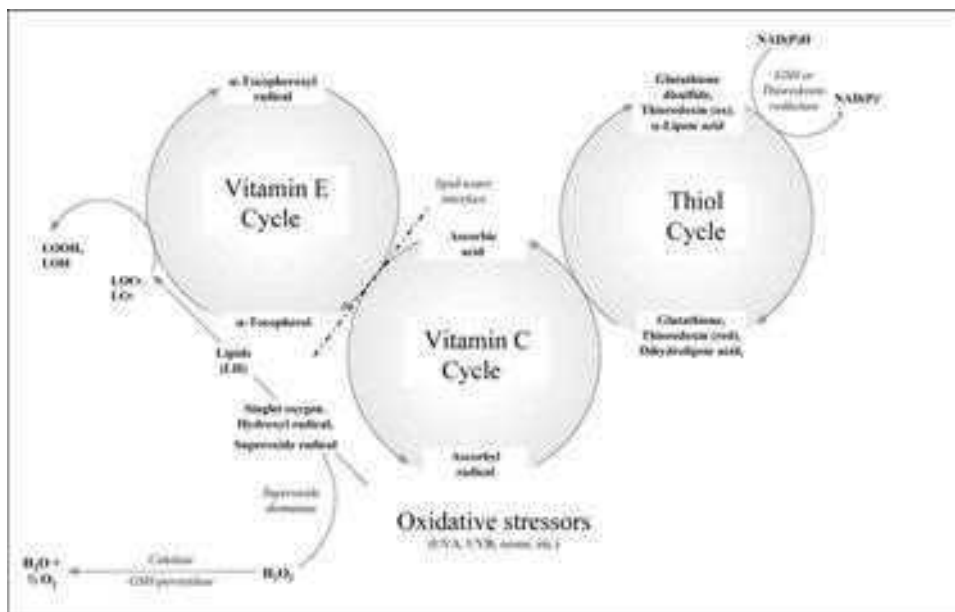
the excited chromophore directly reacts with a substrate molecule via electron or hydrogen atom transfer and gives rise to free radical formation. In the presence of molecular oxygen (minor type II reaction), this reaction may lead to the formation of superoxide anion radical  $\bullet\text{O}_2^-$ . Subsequently,  $\bullet\text{O}_2^-$  gives hydrogen peroxide ( $\text{H}_2\text{O}_2$ ) by a dismutation reaction either spontaneously or catalyzed by cutaneous superoxide dismutase (SOD). Further, in the presence of metal ions such as Fe(II) or Cu(II),  $\text{H}_2\text{O}_2$  can be converted to the highly reactive hydroxyl radical  $\bullet\text{OH}$ . Otherwise (major type II reaction), electronically excited and reactive singlet oxygen  $^1\text{O}_2$  is formed by photo-energy transfer from UVR-excited chromophores in the presence of triplet oxygen  $^3\text{O}_2$  (molecular oxygen in its ground state). Following their formation, ROS species including  $^1\text{O}_2$ ,  $\bullet\text{O}_2^-$ ,  $\bullet\text{OH}$ , and  $\text{H}_2\text{O}_2$  react with an array of skin biomolecules including lipids, proteins, carbohydrates and DNA. For instance, (poly)unsaturated lipids (LH) may react with ROS forming lipid peroxyl ( $\text{LOO}\bullet$ ) and alkoxy radicals ( $\text{LO}\bullet$ ), which may initiate a chain-propagating autocatalytic reaction. Further, ROS cause modifications of amino acids of proteins resulting in functional changes of structural or enzymatic proteins. Besides a multitude of ROS mediated DNA damage, reaction of singlet oxygen with DNA results in the formation of 8-hydroxy-deoxyguanosine.

Since DNA absorbs strongly in the UVB region and is only a weak chromophore in the UVA region, UVB is largely considered as a direct, ROS independent inducer of DNA damage (3). UVB absorption of DNA leads to major base modifications such as pyrimidine dimer or (6-4) photoadduct formation. These modifications together with indirect DNA damage induced by ROS are involved in solar genotoxicity.

## CONSTITUTIVE SKIN ANTIOXIDANT NETWORK

To protect against oxidative stress, the skin is equipped with a complex cooperative network of enzymatic and nonenzymatic antioxidants (1,2). Antioxidant enzymes such as SOD, catalase, glutathione reductase and peroxidase, glutathione-S-transferase and thioredoxin reductase and peroxidase interact with low molecular weight lipophilic antioxidants including vitamin E homologues (tocopherols and tocotrienols) and ubiquinols (coenzyme Q) as well as hydrophilic antioxidants such as vitamin C (ascorbic acid or ascorbate) and glutathione (GSH) (Fig. 13.1). Carotenoids, retinoids and uric acid, also possessing antioxidant activity, were further detected in skin. Their role within the cutaneous antioxidant network is, however, less clear.

$\alpha$ -Tocopherol, the predominant vitamin E homologue in skin, is known to efficiently scavenge lipid peroxyl and alkoxy radicals by intercepting lipid chain propagation, which results in the formation of the metastable tocopheroxyl radical. This



**Figure 13.1** Postulated activation of interactive network of antioxidants and antioxidant enzymes by oxidative stress in skin; note that some of the depicted antioxidant recycling mechanisms have been found *in vitro* and in other than cutaneous systems.

radical formed then either reacts with another lipid radical leading to  $\alpha$ -tocopherol consumption, or abstracts a hydrogen atom from polyunsaturated lipids to give  $\alpha$ -tocopherol and lipid radical. In the latter case, occurring preferentially at low lipid radical concentration, the lipid radical may later react with oxygen to form a lipid peroxy radical. This reaction consequently induces the  $\alpha$ -tocopherol mediated lipid peroxidation chain reaction. Formation of one molecule of  $\alpha$ -tocopherol radical results in the formation of many lipid hydroperoxides. However, as demonstrated *in vitro* in lipid and cellular systems, when ascorbic acid or ubiquinol are present, the tocopheroxyl radical is rapidly reduced regenerating  $\alpha$ -tocopherol. The  $\alpha$ -tocopherol mediated lipid peroxidation chain reaction is thereby terminated. In addition, because of its high reduction potential, ascorbic acid is also an efficient scavenger of a series of ROS such as superoxide anion radicals, hydroxyl radicals, singlet oxygen as well as water soluble peroxy radicals. The resulting ascorbic acid radical can be either recycled to ascorbic acid by coantioxidants such as glutathione or is further oxidized to dehydroascorbic acid and irreversibly decomposed, respectively. Glutathione also reacts with singlet oxygen, superoxide anion radicals and hydroxyl radicals resulting in the formation of the thiyl radical  $GS^\bullet$  and subsequently glutathione disulfide GSSG. The latter can be recycled to GSH by the NAD(P)H-dependent enzyme glutathione reductase.

GSH further acts as a cofactor for numerous reducing enzymes, among them glutathione peroxidases. Glutathione peroxidase is an intracellular selenoenzyme utilizing lipid peroxides as substrate and converting them to hydroxy fatty acids. Glutathione peroxidase also catalyzes the conversion of  $H_2O_2$  into water and oxygen. As mentioned, less reactive  $H_2O_2$  is produced by SOD catalyzing the dismutation reaction of superoxide anion radicals. SOD is present in skin as Cu/Zn- and Mn-SOD. GSH is likewise used by glutathione-S-transferases, which

catalyze the conjugation of GSH to a variety of electrophils including oxidized lipids, DNA and other products generated by ROS-induced damage to these skin biomolecules. Glutathione-S-transferases therefore play an important role in detoxifying products of oxidative stress.

Moreover, skin contains catalase, which similar to glutathione peroxidase eliminates  $H_2O_2$ . However, catalase contributes to scavenging  $H_2O_2$  differently than glutathione peroxidase with respect to its cellular distribution, enzyme stability and reaction rate. The enzymatic activity of catalase is much higher than that of glutathione peroxidase in human epidermis (4). Besides GSH peroxidase, skin contains a further selenium dependent enzyme, thioredoxin reductase (5). Thioredoxin reductase together with its electron acceptor thioredoxin and thioredoxin peroxidase participates similarly as the enzymic thiol redox couple GSH reductase/peroxidase in the cutaneous  $H_2O_2$  turnover.

Along with skin's "interceptive" antioxidant network that scavenge ROS and RNS, skin possesses also mechanism of "antioxidant repair" that are able to reverse oxidatively damaged proteins (6).

In general, nonenzymic antioxidant concentrations as well as enzymic antioxidant activities are significantly higher in the epidermis as compared with the dermis. This probably reflects the fact that epidermis is directly exposed to various exogenous sources of oxidative stress and might have evolved to possess a more pronounced antioxidant defense capacity than dermis to best maintain the redox balance in skin. On a molar basis, hydrophilic nonenzymic antioxidants including L-ascorbic acid, GSH and uric acid appear to be the predominant antioxidants in human skin. Approximately, their dermal and epidermal overall concentrations are more than 10- to 100-fold greater than found for vitamin E or ubiquinol/ubiquinone.

Ascorbic acid, GSH, uric acid (7) and vitamin E (8) as well as catalase and SOD (9,10) were also detected in the outermost

epidermal layer, the human stratum corneum. On the other hand, glutathione peroxidase activity seems not to be detectable in human stratum corneum (10). The stratum corneum consists of a well ordered structure, which is essentially responsible for the exquisite barrier properties of skin. It is composed of flattened, keratin filled corneocytes embedded in a lipid intercellular matrix comprising ceramides, cholesterol and fatty acids. It was found, that the distribution of antioxidants in stratum corneum is not homogeneous, but follows a gradient with lower concentrations toward the skin surface (8). Such a gradient may be explained by the fact that the outer skin layers are more directly exposed to environmental sources of ROS in the presence of relative high concentration of oxygen. A second reason may be related to the longer exposure of the superficial stratum corneum layers to oxidative stress than the lower layers as a consequence of the physiological turnover of keratinocytes during their differentiation process. Interestingly, while human stratum corneum concentrations of vitamin E are as high as in lower epidermal layers, concentrations of hydrophilic antioxidants ascorbic acid and uric acid are in the range of one to two orders of magnitude lower (Thiele J and Packer L, unpublished observations). This is most likely due to the decreased water content of the human stratum corneum as compared with less keratinized epidermal layers.

In contrast to uric acid, GSH and ubiquinol, ascorbic acid and the vitamin E homologues cannot be synthesized by humans and must be taken up by the diet. Consequently, the skin's antioxidant defense may be at least partially influenced by nutritive factors. Knowledge of ascorbic acid's and vitamin E's physiological regulation in skin is only recently emerging. For instance, once ascorbic acid reaches skin via dermal blood vessels, it eventually enters the dermis where it is taken up by fibroblasts using a specific, sodium-dependent vitamin C transporter (SVCT)2; or might further diffuse through the dermis, finally reaching the epidermis and supplying keratinocytes mainly via SVCT1 (11).  $\alpha$ -Tocopherol is known to be a significant constituent of human sebum and is continuously secreted to the skin surface (12). Similarly as for carotenoids (13), sebaceous gland secretion is therefore believed to be a relevant physiological delivery pathway of  $\alpha$ -tocopherol to sebaceous gland-rich skin regions, such as the environmentally exposed facial skin. This may explain the increased levels of  $\alpha$ -tocopherol detected in the upper stratum corneum of facial skin as compared with upper arm skin. The physiological role of vitamin E in human sebum may be to protect against formation of toxic skin surface lipid photooxidation products, such as squalene monohydroperoxides (14).

In addition to its antioxidant activity, L-ascorbic acid acts as cofactor in a multitude of metabolic processes involved in skin formation. For example, it is required in hydroxylation reactions during collagen synthesis to form connective tissue (15) and participates in biosynthesis of epidermal barrier lipids (16).

## EFFECTS OF ENVIRONMENTAL STRESSORS ON SKIN ANTIOXIDANTS

Numerous studies documented the effects of UVR or ozone on cutaneous antioxidants after acute or chronic exposure using different animal models; whereas fewer human studies exist investigating the mechanisms and consequences of such effects (1).

Particularly, the antioxidants contained in the stratum corneum were demonstrated to be susceptible to UVR. For

example, a single suberythemal dose of solar-simulated UVR depleted human stratum corneum  $\alpha$ -tocopherol by almost half, while dermal and epidermal  $\alpha$ -tocopherol were only depleted at much higher doses (8). The high susceptibility of stratum corneum vitamin E to UVR may be, at least in part, due to a lack of coantioxidants in the outermost skin layer. The lipophilic antioxidant ubiquinol-10 (oxidized form of ubiquinol-10), the most abundant ubiquinol/ubiquinone found in human skin, was undetectable in human stratum corneum. Additionally, ascorbic acid, the major hydrophilic coantioxidant that is also capable of recycling photooxidized  $\alpha$ -tocopherol, is present at lower levels in human stratum corneum than in other skin tissues. Because stratum corneum represents a compartmentalized structure, the antioxidants are probably not homogeneously distributed. This may further affect their interactions and thus limit the recycling capacity of  $\alpha$ -tocopherol. The hydrophilic antioxidants were also shown to be sensitive to UVR. Direct depletion of  $\alpha$ -tocopherol and formation of its radical may further affect these endogenous antioxidant pools. However, it seems that ascorbic and uric acid are less susceptible to solar-simulated UVR than  $\alpha$ -tocopherol or ubiquinol-10 as was shown with cultured human skin models (17). In full thickness epidermis of hairless mice, however, ascorbic acid was depleted at lower solar-simulated UV doses than those needed to deplete lipophilic antioxidants or GSH (18). In another study, murine epidermal GSH levels were significantly depleted within minutes after UVB exposure but returned to normal levels after half an hour (19). Moreover, exposures of hairless mice to solar-simulated UVR demonstrated that dermal and epidermal catalase is more susceptible to photoinactivation than SOD, and far more than GSH peroxidase and GSSG reductase (20,21).

Effects of the air pollutant ozone on skin antioxidants have also been reported (1,2). Similarly, as found for UVR exposure, the stratum corneum is the most susceptible skin layer for ozone-induced depletion of lipophilic and hydrophilic antioxidants as was demonstrated using hairless mice. Ozone itself is too reactive to penetrate deeply into the skin and reacts therefore predominantly with the skin barrier lipids and proteins in the outermost epidermis. Comparison of transepidermal water loss changes detected in hairless mice after exposure to either solar-simulated UVR or repetitive high doses of ozone indicated that in skin UVR is a physiologically much more relevant source of oxidative stress than ozone (22).

Changes in antioxidant enzyme activities and nonenzymatic antioxidant levels were investigated in the dermis and epidermis of human skin in vivo revealing a complex regulation of the antioxidant defense system during intrinsic and photoaging processes (9,23). The authors demonstrated that  $\alpha$ -tocopherol concentrations were significantly lower in the epidermis of photoaged and aged skin, but not in the dermis. Ascorbic acid levels were lower in both epidermis and dermis of photoaged and naturally aged skin, respectively. Total glutathione levels were also lower, whereas uric acid concentrations were constant in the epidermis and dermis, respectively. Moreover, it was demonstrated in human skin in vivo, that protein oxidation is increased in intrinsically aged skin, and, most significantly, in photoaged skin. Here, the oxidative damage is most pronounced in the papillary dermis and correlates well with solar elastosis. Remarkably, both protein oxidation as well as a sharp decline in catalase protein levels were also found in the stratum corneum, however not in lower epidermal layers, where antioxidant protection is overall higher

than in dermal and stratum corneum layers (9). Accordingly, an age and UVR dependent decline of stratum corneum catalase was more recently confirmed on the enzyme activity level (10).

### PHOTOPROTECTION OF HUMAN SKIN BY TOPICAL ANTIOXIDANTS

Apart from using sunscreens to diminish the intensity of UVR reaching the skin, supplementation of the skin with topically applied antioxidants and thereby strengthening its antioxidative capacity is an established approach in limiting ROS-induced skin damage (1,2,24). Oral supplementation of antioxidants, which is another promising strategy to prevent cutaneous photodamage, is not subject of this chapter and is reviewed elsewhere (25–27).

Topical application of antioxidants provides an efficient means of increasing antioxidant tissue levels in human epidermis. As the most susceptible skin layer for UVR- and ozone-induced depletion of cutaneous antioxidants, the stratum corneum may particularly benefit from an increased antioxidant capacity due to topical supplementation.

#### Vitamin E

The photoprotective effects of vitamin E ( $\alpha$ -tocopherol) have been studied extensively. Most studies were performed in animals, and several studies exist investigating the photoprotective effects of topically applied vitamin E also in humans (1,2,28). Significantly reduced acute skin responses such as erythema and edema, sunburn cell formation, lipid peroxidation, DNA adduct formation, immunosuppression as well as UVA-induced binding of photosensitizers was demonstrated when vitamin E was applied before UVR exposure. As shown in animal studies, skin wrinkling and skin tumor incidence due to chronic UVR exposure seem also to be diminished by topical vitamin E. A human study proved that an alcoholic lotion containing 2%  $\alpha$ -tocopherol significantly diminished the erythematous responses when applied 30 minutes before UVR exposure at a dose of 2 mg/cm<sup>2</sup> as assessed by measuring skin redness and dermal blood flow (29). Since the lotion had no sunscreening properties the observed photoprotective effect may be attributed to the antioxidant properties of  $\alpha$ -tocopherol. The photoprotective mechanism of action of  $\alpha$ -tocopherol is still subject of debate since investigations on the UVB-induced photooxidation of  $\alpha$ -tocopherol in liposomes indicated that  $\alpha$ -tocopherol might also act as a sunscreen (30).

Diverse vitamin E esters, in particular vitamin E acetate were also shown to be promising agents in reducing UVR-induced skin damage. Their photoprotective effects might be less pronounced as compared with vitamin E; moreover, some studies failed to detect photoprotection provided by vitamin E esters. Vitamin E esters need to be hydrolyzed during skin absorption to show antioxidant activity. For instance, bioconversion of vitamin E acetate into  $\alpha$ -tocopherol; its active antioxidative form, seems slow and occurs only to some extent. There is evidence that vitamin E acetate is not hydrolyzed in the stratum corneum and that its bioconversion into  $\alpha$ -tocopherol only occurs after penetration beyond the stratum corneum into the nucleated epidermis (31). Consequently, the controversial observations of photoprotective effects of topically applied vitamin E acetate may be explained by a limited bioavailability of the active, ester-cleaved form during oxidative stress at the site of action. Intriguingly, the bioconversion of vitamin E acetate into its active form may be enhanced when skin is exposed to

sun, possibly by an UVB dependent increase in esterase activity as demonstrated in murine epidermis (32).

#### Vitamin C

Few studies investigated the photoprotective effects of topical vitamin C (ascorbic acid). Using a porcine skin model, it was demonstrated that topically applied vitamin C protects from UVB-induced erythema and sunburn cell formation when formulated at high concentrations (i.e., 15%) in an appropriate vehicle (i.e., aqueous solution with 15% ethanol adjusted to pH 3.2) (33,34). In a human study, however, a hydroalcoholic lotion with 5% vitamin C was unable to induce any significant photoprotective effects when applied once 30 minutes before irradiation at a dose of 2 mg/cm<sup>2</sup> (29). Besides differences between pig and human skin responses, differences in vitamin C concentration, amount of formulation applied, vehicle composition as well as other experimental parameters may explain this difference in photoprotective efficacy of the vitamin C formulations.

Vitamin C is easily oxidized what makes the development of a stable formulation challenging. Vitamin C can be protected from degradation to some extent at low pH or by appropriate, sophisticated vehicles such as emulsions (35). Furthermore, esterified derivatives such as ascorbyl palmitate or tetraisopalmitate, magnesium or sodium ascorbyl phosphate, and aminopropyl ascorbyl phosphate are more stable and seem therefore promising alternatives to vitamin C (36). As described for vitamin E esters, some of these compounds must be hydrolyzed to vitamin C to manifest antioxidant properties.

Vitamin C does not act as sunscreen; nor does it absorb UVA. In addition to its antioxidant properties, vitamin C participates in synthesis of collagen as cofactor of prolyl and lysyl hydroxylase; enzymes essential for the stabilizing and cross-linking of newly formed collagen molecules. In humans, use of a 5% vitamin C cream resulted in a significantly improved skin relief and a decrease in deep furrows after a six month period of use as compared with placebo (37).

#### Polyphenols

In recent years, extracts from dietary and medical plants have gained considerable attention as efficient agents protecting skin from UVR-induced photodamage after topical application (38–41). Extracts from green tea, milk thistle, soybeans, wine grapes and their seeds, as well as from açai berry, coffee berry, feverfew, pomegranate, tropical ferns, and turmeric were particularly studied. They contain a wide variety of polyphenols known as flavonoids. Polyphenols usually are composed of two or more aromatic rings, each containing at least one hydroxyl group. Flavonoids are divided into flavonols, flavones, catechins, flavanones, anthocyanidins, and isoflavonoids depending on their chemical structure. They are synthesized conjointly with ascorbic acid, vitamin E, GSH and numerous antioxidant enzymes by plants as a response to mitigate cellular damage under oxidative conditions.

Their antioxidant properties arise from their high reactivity as hydrogen or electron donors, from the ability of the polyphenol-derived radical to stabilize the unpaired electron, as well as from their ability to chelate transition metal ions such as Fe(II) and thereby interfering with the hydroxyl radical production. Besides hydroxyl radicals, polyphenols are believed to quench singlet oxygen, superoxide anion radicals and peroxy radicals. Moreover, polyphenolic compounds possess also anti-inflammatory and other properties beneficial for skin.

### Green Tea Polyphenols

Green tea (*Camellia sinensis*) extracts are possibly the most extensively studied plant derived antioxidants for skin (42). In contrast to black tea, which is fermented, green tea leaves contain high concentrations of polyphenols such as epigallocatechin gallate (EGCG). Green tea polyphenols act as antioxidants by scavenging ROS and RNS as well as by sequestering metal ions; and act indirectly as antioxidants through inhibition of "prooxidant" enzymes such as inducible nitric oxide synthase, lipoxygenases and cyclooxygenases; and induction of antioxidant enzymes GSH-S-transferases and SOD (43).

Protective effects of green tea extracts and their major polyphenolic constituent, EGCG, on UVR-induced skin damage after topical application were first observed in several animal models (42). Later, these effects were confirmed in human studies, where topical application of green tea extracts or EGCG significantly decreased erythema responses, lipid peroxidation as well as DNA damage (44,45). More recently, a placebo-controlled study with 40 women with moderate photoaging demonstrated that the combined use of a 10% green tea cream and oral green tea supplementation (300 mg) twice daily for eight weeks resulted in a significant improvement in elastic tissue (46). A trend toward improvement but no significant differences in clinical grading were found between green tea treated group and placebo, however; indicating that a longer treatment period may be required for clinically relevant improvements. In another placebo-controlled study, topical application of a green tea protected human skin from solar-simulated ultraviolet light when applied 15 minutes prior to exposure and reapplied immediately after exposure to two minimum erythema doses (47). The study did not reveal any difference between green and white tea extracts. A further study showed that three-time daily use of a lotion containing 0.4% of a green tea extract with 40% to 50% total polyphenol content helped to reduce UVB-mediated increase in sunburn cell formation (apoptotic keratinocytes) and p53 expression in keratinocytes; but did not reduce erythema or formation of thymidine dimers (48). This study clearly indicates that skincare formulation with relative low concentrations of green tea extracts (i.e., providing about 0.2% total polyphenols)—what makes them more cosmetically acceptable—is efficient for photoprotection.

Green tea extracts and EGCG were further demonstrated to have chemopreventive effects in rodents and therefore prevent cancer. However, epidemiological and human studies are so far little conclusive, which may be the result of multiple factors including different bioavailabilities between humans and rodents (42,49).

### Other Polyphenols

Topical application of silymarin in mice, a milk thistle extract containing silibinin as predominant polyphenol, was shown to inhibit UVB-induced immunosuppression, to reduce UVB-induced sunburn cell formation, to prevent DNA adduct formation as well as to prevent photocarcinogenesis (50,51). Genistein is a major flavonoid constituent of soybean. While much of the reports on genistein have focused on its role as phytoestrogen and tyrosine kinase inhibitor, it has also antioxidant properties. Topical administration of genistein substantially inhibited UVR-induced hydrogen peroxide formation, lipid peroxidation and DNA damage in mice and protects human skin against UVB-induced erythema (52). Another human study evaluating phenolic plant extracts revealed that

topical application of a tropical fern extract reduced erythema as well as UVA-induced immediate pigment darkening and delayed tanning when applied before UVR exposure (53). Coffee berry, the unripe coffee bean, contains diverse (poly)phenolic compounds including chlorogenic acid, quinic acid, ferulic acid and condensed proanthocyanidins. In a clinical study, a skincare system with 1% coffee berry extract resulted in a significant improvement in signs of skin aging when compared with vehicle (54). Pomegranate fruit extract; comprising the polyphenol ellagic acid, possesses strong antioxidant and anti-inflammatory properties and limited UVB-mediated damage in a human reconstituted skin model (55). Another natural extract, a parthenolide-depleted extract of feverfew, which was free of sensitization potential, has free radical scavenging activity against a wide range of ROS. In a clinical study topical feverfew treatment significantly reduced erythema versus placebo 24 hours after UV exposure (56).

Additional studies are warranted to help clarify whether the observed beneficial effects of the botanical extracts or their constituents might not be partially attributed to their sunscreening properties under the respective study conditions (e.g., UVR source, concentration and dose of extract applied per surface area); in particular in the UVA range.

### Thiol Antioxidants

Thiol antioxidants, such as GSH, *N*-acetylcysteine, lipoic acid and their derivatives are another important group of potent radical scavengers (1,2).

Topical administration of GSH, GSH-ethyl ester and *N*-acetylcysteine, respectively, efficiently protected against UVB radiation-induced epidermal lipid peroxidation, cytotoxicity and apoptosis using pig skin *ex vivo* as skin model for assessing short-term biochemical effects related to UVB (57).

Their photoprotective effects have been reported in few clinical studies. Topical treatment with *N*-acetylcysteine under occlusion resulted in an increased GSH level and eliminated its oxidized form (GSSG) in human skin *in vivo* (58). Thus, in addition to its direct antioxidant properties, stimulation of GSH biosynthesis might be a key mechanism accounting for the observed photoprotective effects of *N*-acetylcysteine. In addition, dihydrolipoic acid, the reduced and primarily active antioxidant form of  $\alpha$ -lipoic acid, seems a promising thiol antioxidant potentially protecting against oxidative stress when applied onto skin. Dihydrolipoic acid is known to scavenge singlet oxygen, superoxide anion radicals, hydroxyl radicals and peroxy radicals (2). A placebo-controlled, split-face study with 33 women indicated that several clinical characteristics related to photoageing of facial skin improved after application for 12 weeks of a 5% lipoic acid cream (59).

### Other Antioxidants

The pineal hormone melatonin (*N*-acetyl-5-methoxytryptamine) is also an antioxidant and has been shown to significantly reduce UVR-induced erythema in humans (29). Apart from melatonin's antioxidant properties, its dose-dependent sunscreening properties, as well as its supposed immunomodulatory function might have contributed to the observed photoprotective effects. In addition, *L*-ergothioneine, which is a thiourea derivative of histidine found in food plants and mushrooms, seems another promising potent antioxidant as judged from *in vitro* studies (60). Idebenone, a synthetic analogue of coenzyme Q, which is presumed to penetrate skin more efficiently than its

parent compound, is another potent antioxidant as shown in vitro (61). A clinical study with a 1% idebenone formulation demonstrated a reduction in fine lines/wrinkles in female subjects between 30 to 65 years of age with moderate photodamage (62). This study was not vehicle controlled. Furthermore, a study in pigs revealed that idebenone offers little to no photoprotective effects when applied daily for four days before irradiation with solar-simulated UV radiation up to five minimal erythema doses (63).

### Antioxidant Combinations

As illustrated when discussing the cutaneous antioxidant system, antioxidants interact when combined and emanating radical or oxidized forms of antioxidants after ROS scavenging may be quickly regenerated in the presence of appropriate coantioxidants. Accordingly, an enhanced photoprotective effect may be obtained by applying distinct combinations of antioxidants. For instance, ample evidence exists about the interactive dependence of vitamins C and E in diminishing photodamage in vivo.

As was shown in humans, a single topical application of a combination of 2% vitamin E and 5% vitamin C resulted in more pronounced photoprotective effect as compared with the application of either antioxidant alone in the identical vehicle (29). As demonstrated in the same study, the most dramatic improvement resulted from the coformulation of melatonin together with  $\alpha$ -tocopherol and ascorbic acid. It may be speculated that possible synergistic interactions between melatonin and the vitamins E and C could have contributed to the observed, significantly increased photoprotective effects.

Other distinct mixtures of topically applied antioxidants were also shown to be more effective in reducing photodamage than single antioxidants. Adding 0.5% ferulic acid (a phenolic antioxidant found in plants) to a solution of 1%  $\alpha$ -tocopherol and 15% ascorbic acid doubled photoprotection to solar-simulated irradiation of pig skin when applied topically from four- to eightfold as measured by both erythema and sunburn cell formation (64). Another combination consisting of ferulic acid with tocopheryl acetate and  $\alpha$ -glycosylrutin was shown to limit the severity of experimentally induced polymorphous light eruptions when applied one week prior to photoprovocation with UVA in humans (65). Recently, remarkably enhanced antioxidative efficacy as compared with additive efficacy was found for the mixture green tea polyphenols,  $\alpha$ -tocopherol and ascorbic acid (66). Kinetic and mechanistic studies revealed that the antioxidant synergism was due to the regeneration of  $\alpha$ -tocopherol by the green tea polyphenols, while latter are regenerated by ascorbic acid. Therefore, the antioxidant synergism between green tea polyphenols, ascorbic acid and  $\alpha$ -tocopherol makes this combination particularly interesting for antioxidant protection.

### CONCLUDING COMMENTS

Animal and human studies have convincingly demonstrated that topical application of antioxidants helps protect skin from UV-induced damages. The protective effects in humans were particularly well studied for ascorbic acid, tocopherol, some of their ester derivatives, and polyphenolic antioxidant mixtures including green tea extracts. Their efficacy was significantly increased when applied as combination; whereas the combination of ascorbic acid, tocopherol and ferulic acid or, respectively,

green tea, appear synergistic antioxidant combinations. Accordingly, regular application of skincare products containing antioxidants efficiently prepare skin against exogenous oxidative stressors occurring during daily life. Since sunlight induced skin damage is not solely dependent on occurrence of oxidative stress, antioxidant supplementation cannot be presumed to give complete photoprotection. In fact, photoprotective effects of most antioxidants are modest as compared with sunscreens. Therefore, sunscreens are indispensable in the effective prevention of skin photodamage. Nevertheless, sunscreens benefit from combination with antioxidants resulting in increased efficacy of such photoprotective products. This was first recognized by Darr and coworkers who were able to demonstrate that a combination of vitamins C and E with oxybenzone resulted in an apparently greater than additive protection against phototoxic damage in pigs (67). This observation was later confirmed by others in humans (29,68).

It is important to keep in mind that antioxidants are mostly of protective nature (i.e., from oxidative stress) and, with the exclusion of L-ascorbic acid, generally have no effect in reversing skin wrinkles or folds. Only agents that promote collagen formation including retinoic acid or human growth factors such as basic fibroblast growth factor or transforming growth factors  $\beta$  may reverse signs of skin aging (69). Few antioxidants, however, have effects beyond their "pure" ROS and RNS scavenging activity, which are relevant in extracellular matrix metabolism. For instance, as shown in artificial skin, EGCG (major polyphenol in green tea extract) decreased the level of matrix metalloproteinase (MMP) production and increased their tissue inhibitor (TIMP) expression level similarly as retinoic acid (70).

In addition, when comparing potency between different antioxidants for topical use in humans, the comparison should be preferentially based on in vivo data. Comparisons based on in vitro tests including the oxygen radical absorbance capacity (ORAC) assays are debatable since such tests are limited and do not take into account absorption, distribution, metabolism and elimination after topical application on human skin (41).

### REFERENCES

1. Thiele JJ, Dreher F, Packer L. Antioxidant defense systems in skin. In: Elsner P, Maibach HI, eds. *Cosmeceuticals—Drugs vs. Cosmetics*. New York: Dekker, 2000:145–187.
2. Thiele J, Elsner P. Oxidants and antioxidants in cutaneous biology. In: Burg G, ed. *Current Problem in Dermatology*. Volume 29. Basel: Karger, 2001.
3. Chang H, Oehrl W, Elsner P, et al. The role of H<sub>2</sub>O<sub>2</sub> as a mediator of UVB induced apoptosis in keratinocytes. *Free Radic Res* 2003; 37:655–663.
4. Shindo Y, Witt E, Han D, et al. Enzymic and non-enzymic antioxidants in epidermis and dermis of human skin. *J Invest Dermatol* 1994; 102:122–124.
5. Schallreuter KU, Wood JM. Thioredoxin reductase – its role in epidermal redox status. *J Photochem Photobiol B* 2001; 64:179–184.
6. Taungjaruwina WM, Bhawan J, Keady M, et al. Differential expression of the antioxidant repair enzyme methionine sulfoxide reductase (MSRA and MSRB) in human skin. *Am J Dermatopathol* 2009; 31:427–431.
7. Weber SU, Thiele JJ, Cross CE, et al. Vitamin C, uric acid and glutathione gradients in murine stratum corneum and their susceptibility to ozone exposure. *J Invest Dermatol* 1999; 113:1128–1132.
8. Thiele JJ, Traber MG, Packer L. Depletion of human stratum corneum vitamin E: an early and sensitive in vivo marker of UV-induced photooxidation. *J Invest Dermatol* 1998; 110:756–761.

9. Sander CS, Chang H, Salzmann S, et al. Photoaging is associated with protein oxidation in human skin in vivo. *J Invest Dermatol* 2002; 118:618–625.
10. Hellems L, Corstjens H, Neven A, et al. Antioxidant enzyme activity in human stratum corneum shows seasonal variation with an age-dependent recovery. *J Invest Dermatol* 2003; 120:434–439.
11. Stelling H, Longet K, Moodycliffe A, et al. Sodium-dependent vitamin C transporter isoforms in skin: distribution, kinetics, and effect of UVB-induced oxidative stress. *Free Radic Biol Med* 2007; 43:752–762.
12. Thiele JJ, Weber SU, Packer L. Sebaceous gland secretion is a major physiological route of vitamin E delivery to skin. *J Invest Dermatol* 1999; 113:1006–1010.
13. Darvin ME, Fluhr JW, Caspers P, et al. In vivo distribution of carotenoids in different anatomical locations of human skin: comparative assessment with two different Raman spectroscopy methods. *Exp Dermatol* 2009; 18(12):1060–1063.
14. Ekanayake Mudiyansele S, Hamburger M, Elsner P, et al. Ultraviolet A induces generation of squalene monohydroperoxide isomers in human sebum and skin surface lipids in vitro and in vivo. *J Invest Dermatol* 2003; 120:915–922.
15. Davidson JM, LuValle PA, Zoia O, et al. Ascorbate differentially regulates elastin and collagen biosynthesis in vascular smooth muscle cells and skin fibroblasts by pretranslational mechanisms. *J Biol Chem* 1997; 272:345–352.
16. Ponc M, Weerheim A, Kempenmaer J, et al. The formation of competent barrier lipids in reconstructed human epidermis requires the presence of vitamin C. *J Invest Dermatol* 1997; 109:348–355.
17. Podda M, Traber MG, Weber C, et al. UV-irradiation depletes antioxidants and causes oxidative damage in a model of human skin. *Free Radic Biol Med* 1998; 24:55–65.
18. Shindo Y, Witt E, Han D, et al. Recovery of antioxidants and reduction in lipid hydroperoxides in murine epidermis and dermis after acute ultraviolet radiation exposure. *Photodermatol Photoimmunol Photomed* 1994; 10:183–191.
19. Connor MJ, Wheeler LA. Depletion of cutaneous glutathione by ultraviolet radiation. *Photochem Photobiol* 1987; 46:239–245.
20. Shindo Y, Witt E, Packer L, et al. Antioxidant defense mechanisms in murine epidermis and dermis and their responses to ultraviolet light. *J Invest Dermatol* 1993; 100:260–265.
21. Shindo Y, Witt E, Han D, et al. Dose-response effects of acute ultraviolet irradiation on ultraviolet irradiation on antioxidants and molecular markers of oxidation in murine epidermis and dermis. *J Invest Dermatol* 1994; 102:470–475.
22. Thiele JJ, Dreher F, Maibach HI, et al. Impact of ultraviolet radiation and ozone on transepidermal water loss as a function of skin temperature in hairless mice. *Skin Pharmacol Appl Skin Physiol* 2003; 16(5):283–290.
23. Rhie G, Shin MH, Seo JY, et al. Aging- and photoaging-dependent changes of enzymic and nonenzymic antioxidants in the epidermis and dermis of human skin in vivo. *J Invest Dermatol* 2001; 117:1212–1217.
24. Pinnell SR. Cutaneous photodamage, oxidative stress, and topical antioxidant protection. *J Am Acad Dermatol* 2003; 48:1–19.
25. Fuchs J. Potentials and limitations of the natural antioxidants RRR- $\alpha$ -tocopherol, L-ascorbic acid and  $\beta$ -carotene in cutaneous photoprotection. *Free Radic Biol Med* 1998; 25:848–873.
26. Boelsma E, Hendriks HFJ, Roza L. Nutritional skin care: health effects of micronutrients and fatty acids. *Am J Clin Nutr* 2001; 73:853–864.
27. Bialy TL, Rothe MJ, Grant-Kels JM. Dietary factors in the prevention and treatment of nonmelanoma skin cancer and melanoma. *Dermatol Surg* 2002; 28:1143–1152.
28. Thiele JJ, Ekanayake-Mudiyansele S. Vitamin E in human skin: organ-specific physiology and considerations for its use in dermatology. *Mol Aspects Med* 2007; 28:646–667.
29. Dreher F, Gabard B, Schwindt DA, et al. Topical melatonin in combination with vitamins E and C protects skin from UV-induced erythema: a human study in vivo. *Br J Dermatol* 1998; 139:332–339.
30. Kramer KA, Liebler DC. UVB induced photooxidation of vitamin E. *Chem Res Toxicol* 1997; 10:219–224.
31. Baschong W, Artmann C, Hueglin D, et al. Direct evidence for bioconversion of vitamin E acetate into vitamin E: an ex vivo study in viable human skin. *J Cosmet Sci* 2001; 52:155–161.
32. Kramer-Stickland KA, Liebler DC. Effect of UVB on hydrolysis of  $\alpha$ -tocopherol acetate to  $\alpha$ -tocopherol in mouse skin. *J Invest Dermatol* 1998; 111:302–307.
33. Darr D, Combs S, Dunston S, et al. Topical vitamin C protects porcine skin from ultraviolet radiation-induced damage. *Br J Dermatol* 1992; 127:247–253.
34. Lin JY, Selim MA, Shea CR, et al. UV photoprotection by combination topical antioxidants vitamin C and vitamin E. *J Am Acad Dermatol* 2003; 48:866–874.
35. Gallarate M, Carlotti ME, Trotta M, et al. On the stability of ascorbic acid in emulsified systems for topical and cosmetic use. *Int J Pharm* 1999; 188:233–241.
36. Farris PK. Topical vitamin C: a useful agent for treating photoaging and other dermatologic conditions. *Dermatol Surg* 2005; 31:814–817.
37. Humbert PG, Haftek M, Creidi P, et al. Topical ascorbic acid on photoaged skin. Clinical, topographical and ultrastructural evaluation: double-blind study vs. placebo. *Exp Dermatol* 2003; 12:237–244.
38. Afaq F, Mukhtar H. Photochemoprevention by botanical antioxidants. *Skin Pharmacol Appl Skin Physiol* 2002; 15:297–306.
39. Berson DS. Natural antioxidants. *J Drugs Dermatol* 2008; 7(7 suppl):s7–s12.
40. Baumann L, Woolery-Lloyd H, Friedman A. “Natural” ingredients in cosmetic dermatology. *J Drugs Dermatol* 2009; 8(6 suppl):s5–s9.
41. Ditre C, Wu J, Baumann LS, et al. Innovations in natural antioxidants and their role in dermatology. *Cutis* 2008; 82(6 suppl):2–16.
42. Hsu S. Green tea and the skin. *J Am Acad Dermatol* 2005; 52:1049–1059.
43. Frei B, Higdon JV. Antioxidant activity of tea polyphenols in vivo: evidence from animal studies. *J Nutr* 2003; 133:3275S–3284S.
44. Katiyar SK, Afaq F, Perez A, et al. Green tea polyphenol (-)-epigallocatechin-3-gallate treatment of human skin inhibits ultraviolet radiation-induced oxidative stress. *Carcinogenesis* 2001; 22:287–294.
45. Elmets CA, Singh D, Tubesing K, et al. Cutaneous photoprotection from ultraviolet injury by green tea polyphenols. *J Am Acad Dermatol* 2001; 44:425–432.
46. Chiu AE, Chan JL, Kern DF, et al. Double-blinded, placebo-controlled trial of green tea extracts in the clinical and histologic appearance of photoaging skin. *Dermatol Surg* 2005; 3:855–860.
47. Camouse MM, Domingo DS, Swain FR, et al. Topical application of green and white tea extracts provides protection from solar-simulated ultraviolet light in human skin. *Exp Dermatol* 2009; 18:522–526.
48. Mnich CD, Hoek KS, Virkki LV, et al. Green tea extract reduces induction of p53 and apoptosis in UVB-irradiated human skin independent of transcriptional controls. *Exp Dermatol* 2009; 18:69–77.
49. Boehm K, Borrelli F, Ernst E, et al. Green tea (*Camellia sinensis*) for the prevention of cancer. *Cochrane Database Syst Rev* 2009; 8(3): CD005004.
50. Singh RP, Agarwal R. Flavonoid antioxidant silymarin and skin cancer. *Antioxid Redox Signal* 2002; 4:655–663.
51. Saller R, Melzer J, Reichling J, et al. An updated systematic review of the pharmacology of silymarin. *Forsch Komplementmed* 2007; 14:70–80.
52. Wei H, Saladi R, Lu Y, et al. Isoflavone genistein: photoprotection and clinical implications in dermatology. *J Nutr* 2003; 133:3811S–3819S.
53. González S, Pathak MA, Cuevas J, et al. Topical or oral administration with an extract of *Polypodium leucotomos* prevents acute



- sunburn and psoralen-induced phototoxic reactions as well as depletion of Langerhans cells. *Photodermatol Photoimmunol Photomed* 1997; 13:50–60.
54. Farris P. Idebenone, green tea, and Coffeeberry<sup>®</sup> extract: new and innovative antioxidants. *Dermatol Ther* 2007; 20:322–329.
  55. Afaq F, Zaid MA, Khan N, et al. Protective effect of pomegranate-derived products on UVB-mediated damage in human reconstituted skin. *Exp Dermatol* 2009; 18:553–561.
  56. Martin K, Sur R, Liebel F, et al. Parthenolide-depleted Feverfew (*Tanacetum parthenium*) protects skin from UV irradiation and external aggression. *Arch Dermatol Res* 2008; 300:69–80.
  57. Rijnkels JM, Moison RMW, Podda E, et al. Photoprotection by antioxidants against UVB-radiation-induced damage in pig skin organ culture. *Radiat Res* 2003; 159:210–217.
  58. Kang S, Chung JH, Lee JH, et al. Topical N-acetyl cysteine and genistein prevent ultraviolet-light-induced signaling that leads to photoaging in human skin in vivo. *J Invest Dermatol* 2003; 120:835–841.
  59. Beitner H. Randomized, placebo-controlled, double blind study on the clinical efficacy of a cream containing 5% alpha-lipoic acid related to photoageing of facial skin. *Br J Dermatol* 2003; 149:841–849.
  60. Dong KK, Damaghi N, Kibitel J, et al. A comparison of the relative antioxidant potency of L-ergothioneine and idebenone. *J Cosmet Dermatol* 2007; 6:183–188.
  61. McDaniel DH, Neudecker BA, Dinardo JC, et al. Idebenone: a new antioxidant—part I. Relative assessment of oxidative stress protection capacity compared to commonly known antioxidants. *J Cosmet Dermatol* 2005; 4:10–17.
  62. McDaniel D, Neudecker B, Dinardo J, et al. Clinical efficacy assessment in photodamaged skin of 0.5% and 1% idebenone. *J Cosmet Dermatol* 2005; 4:167–173.
  63. Tournas JA, Lin FH, Burch JA, et al. Ubiquinone, idebenone, and kinetin provide ineffective photoprotection to skin when compared to a topical antioxidant combination of vitamins C and E with ferulic acid. *J Invest Dermatol* 2006; 126:1185–1187.
  64. Lin FH, Lin JY, Gupta RD, et al. Ferulic acid stabilizes a solution of vitamins C and E and doubles its photoprotection of skin. *J Invest Dermatol* 2005; 125:826–832.
  65. Hadshiew I, Stäb F, Untiedt S, et al. Effects of topically applied antioxidants in experimentally provoked polymorphous light eruption. *Dermatology* 1997; 195:362–368.
  66. Dai F, Chen WF, Zhou B. Antioxidant synergism of green tea polyphenols with  $\alpha$ -tocopherol and L-ascorbic acid in SDS micelles. *Biochimie* 2008; 90:1499–1505.
  67. Darr D, Dunston S, Faust H, et al. Effectiveness of antioxidants (vitamin C and E) with and without sunscreens as topical photoprotectants. *Acta Derm Venereol* 1996; 76:264–268.
  68. Matsui MS, Hsia A, Miller JD, et al. Non-sunscreen photoprotection: antioxidants add value to a sunscreen. *J Invest Dermatol Symp Proc* 2009; 14:56–59.
  69. Rangarajan V, Dreher F. Topical growth factors for skin rejuvenation. In: Farage MA, Miller KW, Maibach HI, eds. *Textbook of Skin Aging*. Berlin: Springer, 2010:1079–1087.
  70. Lee JH, Chung JH, Cho KH. The effects of epigallocatechin-3-gallate on extracellular matrix metabolism. *J Dermatol Sci* 2005; 40:195–204.

# Topical retinol: an efficacious solution for improvement of main photodamage signs

Christiane Bertin and Thierry Oddos

## INTRODUCTION

Clinically, skin aging is associated with a variety of signs such as wrinkles, uneven pigmentation, skin roughness, skin color, and laxity. These clinical features are consecutive to the structural and metabolic changes that occur during the passage of time (chronological aging). However, external factors, such as repeated skin exposure to solar ultraviolet (UV) radiation, can induce premature or photoaging of the skin. These changes are consecutive to a decrease in fibroblast number as well as collagen synthesis and an increase in UV-induced collagen degradation by matrix metalloproteinases (MMPs). An accumulation of nonfunctional elastin is also observed in the dermis, leading to a loss of skin elasticity and firmness. In addition, a constant hallmark of skin aging and photoaging is epidermal thinning, which is triggered by a decrease in keratinocyte turnover rate (1). Photoaging is also associated with a dysregulation in melanin synthesis and distribution and a general increase in the inflammatory status of the skin leading to the appearance of brown spots, a global increase in skin redness, and telangiectasia.

Retinoids have shown beneficial effects in reducing skin photoaging. For instance, it has been demonstrated that all-trans retinoic acid (ATRA) improves skin photoaging signs (2,3). This clinical efficacy was mainly attributed to the effect of ATRA on collagen metabolism by stimulation of the collagen synthesis that ultimately accumulates in the upper part of the papillary dermis (3,32). Moreover ATRA downregulates UV-induced MMP1 and MMP9 expression (4,5), thereby replenishing collagen levels. Although ATRA is recognized as an effective therapy for the treatment of photoaged skin through its regulatory effect on collagen metabolism, it has been suggested that retinol (ROL), known as vitamin A, may also alleviate some major signs of photoaging with a better irritation profile.

Retinoids are all derived from the naturally occurring all-trans retinol. This molecule is composed of 15 carbons. Three parts of the molecule can be distinguished: a cyclic group, a polyene group, and a polar group [primary alcohol for retinol  $-CH_2OH$ , and aldehyde  $-CHO$  for retinaldehyde and a carboxylic function  $-COOH$  for retinoic acid, the two latter compounds being obtained from the previous by oxidation (Fig. 14.1)]. Natural isomers carrying specific biological activities have also been described as 11-*cis*-retinaldehyde and 9-*cis*-retinoic acid.

## METABOLISM OF RETINOL

Diet is the normal source of retinol in the body. It originates from carotenoids in plants and of the long chain fatty acid esters of retinol (as retinyl palmitate) in animal tissue.

Carotenoids are split, in the intestine epithelium, in the middle of the molecule to form retinal, which is in turn reduced to retinol and esterified into retinyl ester. Retinyl esters are transported and stored in the liver, which is the main storage site in the body. The retinol is then delivered in the blood stream associated with a specific transporter retinol-binding protein (RBP). In normal conditions, most of the circulating retinol is associated with RBP and the level of retinol in healthy volunteers fluctuates above 30  $\mu\text{g}/\text{mL}$  (6).

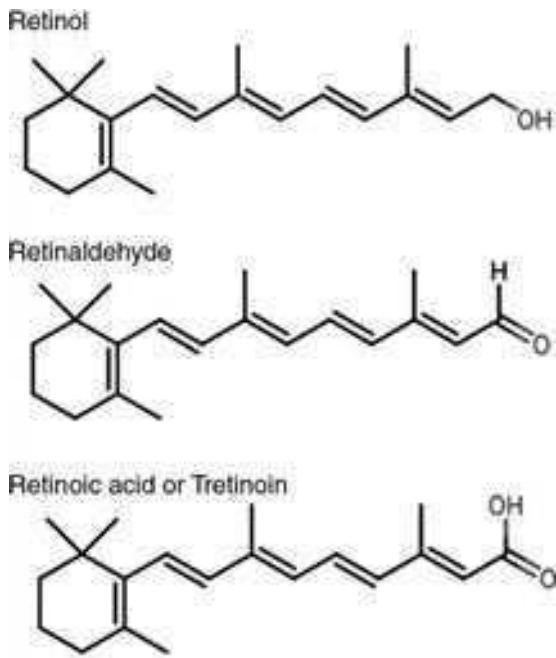
In the skin, at the keratinocyte level, retinol uptake is mediated through the binding of RBP-retinol complex to specific receptor(s), such as the 61 kDa retinal pigment epithelium (RPE) protein, and internalization (7-9).

In keratinocytes, retinol is stored in the form of retinyl esters (i.e., mainly palmitate, oleate, and acetate esters) (10,11) primarily through the action of lecithin-retinol acyltransferase (12). It is then oxidized into retinal and retinoic acid by different alcohol dehydrogenases (13). Two other proteins responsible for retinol transportation play an important role in retinol metabolism. The first one is the cellular retinol-binding protein (CRBP), which shows a high affinity for all-trans retinol. The second one is the cellular retinoic acid-binding proteins (CRABP I and CRABP II) that bind specifically retinoic acid. In skin, CRABP II is the predominant retinoic acid protein and its expression is enhanced by keratinocyte differentiation and treatment with retinoids. The role of these proteins is not completely clarified. CRBP could play a role in presenting the retinol in the adequate conformation to the dehydrogenase. They are also believed to control the level of free retinol and free retinoic acid and the translocation of these two molecules in specific cellular compartments such as translocation of retinoic acid in the nucleus for CRABP II (14).

## BIOLOGICAL EFFECT ON SKIN AND ON DIFFERENT CELL TYPES

Retinol plays a major role in the skin, as it is essential for regulating keratinocyte differentiation as suggested by the early observation of abnormal keratinization in vitamin A-deficient rats (15) and humans (16). Topically retinol stimulates the proliferation of the basal keratinocytes through the release of heparin-binding epidermal growth factor (HB-EGF) from suprabasal keratinocytes (17,18). The influence of retinol on keratinocyte differentiation is shown by the increase of some differentiation markers as keratins (keratin 4, keratin 10, keratin 13, and cytokeratin 19), while others like filaggrin, transglutaminase-1, or loricrin are decreased.

The overall effect on the epidermis is a stimulation of the cell proliferation in basal and suprabasal layers and an



**Figure 14.1** Structure of most common retinoids (all trans conformation).

inhibition of the terminal differentiation of the keratinocytes. Taken together, this leads to a general thickening of the epidermis (10).

On dermal fibroblasts, retinol showed a potent stimulation of growth of fibroblasts from aged donors and a stimulation of the synthesis of procollagen I and procollagen III (19).

Retinol represses the overexpression of UV-induced MMP1 and MMP9, two enzymes involved in the degradation of collagen molecules. The underlying mechanism is the repression by activated retinoic receptor of the AP1 transcriptional activity that drives the expression of MMP1, MMP3, and MMP9. Indeed, skin exposure to UV light leads to the stimulation of the MAP kinases such as ERK, JNK, or P38 and then to the overexpression of the Jun protein that controls the level of AP1 in the cell. Thus, retinol is able to decrease the UV-induced overexpression of MMPs and to increase collagen synthesis, two mechanisms that could explain in part its potential to protect the skin against photodamage (4).

## CLINICAL ASPECT

Retinoids have been widely studied during the past 20 years for their activity on human skin. In 1969, Kligman et al. (20) proved the therapeutic efficacy of topical ATRA in acne vulgaris and later in 1986 (21), pioneered the use of retinoids in cosmetic dermatology by demonstrating its effects on photoaged skin. He conducted an open study on 8 elderly patients receiving 0.05% ATRA cream on the face for 6 to 12 months, while 6 other patients received the vehicle alone. Although only slight clinical differences were observed, histology showed a thickening of the previously atrophic epidermis, decrease of keratinocyte dysplasia and atypia, more even dispersion of melanin and formation of new dermal collagen and blood vessels.

Since then, several clinical studies were performed to assess the activity of ATRA on humans, especially in the treatment of photoaging signs: Weiss and Voorhees in 1988 (22) performed the first double-blind randomized placebo-controlled study by applying 0.1% ATRA on the forearm and face of 30 patients for 16 weeks. They demonstrated a significant improvement of photoaging in the ATRA-treated areas. The greatest improvement was in the reduction of fine wrinkles, with a statistically significant difference occurring eight weeks after beginning the study. Other features such as coarse wrinkles, roughness, and sallowness also showed an improvement but to a lesser degree. Lever in 1990 (23) using a preparation containing 0.05% ATRA during 12 weeks observed an improvement in clinical grading of photoaging (fine lines and wrinkles). Grove again in 1991 (24) assessing different concentrations of ATRA (from 0.05% to 0.001%) over 24 weeks demonstrated a better efficacy of the dose activity with the highest concentration (0.05%) of the ingredient on the Rz parameter (local mean amplitude) on skin replicas. Olsen in 1992 (25) on 296 subjects with the same ranking of concentrations as Grove, over a 24-week period showed a decrease of skin roughness, hyper pigmentation, and fine wrinkling.

Unfortunately, ATRA tends to be irritating, with many patients experiencing redness, flaking, and increased skin sensitivity. Some patients also reported an increased sun sensitivity during ATRA therapy (26).

Retinol, an alternative to ATRA, has fewer side effects and is a better tolerated additive in cosmetic preparations for the improvement of photodamage signs. In 1995, Kang et al. demonstrated that the application of retinol up to 1.6%, on human skin under an occlusive patch, was unable to induce significant erythematous reaction versus vehicle. It also evokes the same physiological response as the 0.025% erythemal concentration of retinoic acid as demonstrated by epidermal thickening and the enhancement of CRABP II mRNA and protein expression. This retinoid activity of retinol was obtained without a detectable increase of retinoic acid in the epidermis (10). Duell et al. (27) showed that topical retinol penetrated the epidermis more and produced less irritation than the acid form. Finally, Goffin in 1997 (28) tested 0.075% of retinol for eight weeks with corneosurfametry and demonstrated its better tolerance versus ATRA.

## CLINICAL EFFICACY OF RETINOL

Although retinol was demonstrated to induce, in human skin, a physiological response typical of retinoids, only a few clinical studies were published demonstrating its efficacy in improving the signs of skin aging. In 2007, Kafi et al. reported a clinical study to demonstrate the beneficial effect of retinol on the skin signs associated with chronological aging. This randomized study versus vehicle was performed on 23 elderly subjects over 80 years (average 87 years old). Retinol 0.4% and vehicle were topically applied on the upper inner arm for 6 months. The results showed a significant improvement in fine wrinkles versus vehicle after 2 months of application. This improvement increased with the continued application of retinol and was associated with a significant better tactile roughness and overall severity in chronologically aged skin. Skin biopsies demonstrated a thickening of the epidermis and a significant increase in GAG expression and procollagen I accumulation in the dermis compared to the vehicle-treated arm. In this study, although rated as mild, adverse reactions were reported by



**Figure 14.2** Example of improvement of crow's feet area by retinol 0.1% product treatment.

most subjects including erythema, peeling, pruritus, dryness, and burning or stinging with the withdraw of three subjects following severe enough symptoms (29).

We explored the action of retinol at a lower concentration (0.1%) on a photoexposed area to investigate the antiaging effect of retinol at more tolerated doses on the photoaging signs. In a first blind randomized vehicle-controlled study, 48 volunteers (41–60 years old) topically applied to the face either the retinol 0.1% containing product or the vehicle, every day for 56 weeks. The clinical evaluation performed by an expert grader after 12, 24, and 56 weeks of application showed that wrinkles under the eyes, fine lines at the crow's feet area, and skin tone evenness significantly improved versus both baseline and vehicle. The improvement of the fine lines in the crow's feet area was also demonstrated with digital imaging and with surface profilometry. A progressive improvement was seen between baseline and after 24 and 36 weeks of treatment (Fig. 14.2). The improvement in fine lines was also documented by surface profilometry and a progressive disappearance of the fine lines in the crow's feet area was observed. Moreover, we demonstrated that retinol stimulates epidermal cell proliferation along with the treatment. Indeed, the epidermal cell turnover rate was evaluated using *in vivo* fluorescence spectroscopy by measuring the fluorescence maximum attributed to tryptophan moieties. The placebo-treated group did not show any significant change from baseline for any time point. In contrast, the intensity of tryptophan fluorescence increased for the actively treated group evident from the first time point (12 weeks vs. baseline), and then it appeared to reach a plateau. Most importantly, the change in the fluorescence intensity from baseline was significantly higher for the active-treated group than for the placebo-treated group at the 36-week time point (30). These antiaging effects of retinol were confirmed in two other shorter term double-blind randomized studies performed with moisturizing product containing 0.1% retinol. In the first study, the retinol-containing products were topically applied on 40 subjects (40–60 years old) once a day for 8 weeks. The effect of the product was compared to the effect of its vehicle on 41 subjects. The results presented in Table 14.1 showed that the application of the retinol 0.1% significantly improved the facial features of photodamaged areas as early as 4 weeks of use. Results from the second study were recently published (31). In this 8 week, split face, double-blind, randomized clinical study, a 0.1% retinol-containing moisturizer was tested (36 subjects) versus placebo (28 subjects) in women with moderate facial photodamage. Clinical evaluation of photodamage signs by a dermatologist demonstrated significant improvement versus placebo of fine lines, wrinkles, elasticity, firmness,

**Table 14.1** Clinical Assessment of Retinol Antiaging Efficacy

Parameter	Vehicle		Retinol 0.1%	
	4 wk	8 wk	4 wk	8 wk
Under eye wrinkles (%)	0	2.2	4.3 <sup>a,b</sup>	6.5 <sup>a,b</sup>
Crow's-feet fine lines (%)	8.1 <sup>a</sup>	10.8 <sup>a</sup>	29.7 <sup>a,b</sup>	35.1 <sup>a,b</sup>
Crow's-feet wrinkles (%)	0	0	2.8 <sup>a</sup>	8.3 <sup>a,b</sup>
Forehead wrinkles (%)	0	0	6.4 <sup>a,b</sup>	6.4 <sup>a,b</sup>
Skin radiance (%)	16.7 <sup>a</sup>	20.8 <sup>a</sup>	34.8 <sup>a,b</sup>	43.5 <sup>a,b</sup>
Cheek wrinkles (%)	0	0	7.3 <sup>a,b</sup>	9.8 <sup>a,b</sup>
Overall photodamage (%)	3.8 <sup>a</sup>	3.8 <sup>a</sup>	17.3 <sup>a,b</sup>	19.2 <sup>a,b</sup>

Values represent the percentage of improvement versus baseline.

<sup>a</sup>Statistical significance versus baseline ( $p < 0.05$ ).

<sup>b</sup>Statistical significance versus vehicle ( $p < 0.05$ ).

and overall photodamage after four weeks. Thus, using a low level of retinol (e.g., 0.1%) could still deliver a significant and rapid antiaging efficacy while maintaining a good tolerance profile, as only a few subjects experienced a slight adverse skin reaction without any withdrawal with the retinol product. In the two studies, the number of adverse reactions observed with the retinol product was not significantly higher than with the vehicle.

## CONCLUSION

Skin aging is a complex process involving numerous different mechanisms such as loss of cell proliferation, decreased potential of extracellular matrix synthesis, and overexpression of matrix-degrading proteinases. Retinoids are naturally present in the skin and regulate epidermal cell differentiation, activate collagen synthesis, and attenuate the UV-induced overexpression of MMPs. The potential of regulating several pathways involved in skin chronological and photoaging makes them good candidates as active ingredients to alleviate facial aging signs. Although retinoic acid has been the first retinoids to demonstrate an efficacious wrinkle improvement, the severe side effects induced by its topical application warrants the identification of other retinoids for this benefit. Therefore, retinol was identified as a good alternative to retinoic acid, as its topical application induces low level of skin adverse reaction while delivering physiological skin responses similar to those induced by retinoic acid. Moreover, retinoic acid level in the epidermis observed after topical application of retinol is extremely low or undetectable and thus provides a substantial margin of safety with respect to possible systemic effect.

Results presented here focus preferentially on the clinical efficacy of well-tolerated doses of retinol. Indeed in two double-blind randomized placebo-controlled studies, retinol at 0.1% demonstrated a significant visible improvement of facial aging features such as fine lines and wrinkles within one month's time.

## REFERENCES

- Baumann L. Skin ageing and its treatment. *J Pathol* 2007; 211: 241–251.
- Griffiths CE, Russman AN, Majmudar G, et al. Restoration of collagen formation in photodamaged human skin by tretinoin (retinoic acid). *N Engl J Med* 1993; 329:530–535.
- Griffiths CE, Voorhees JJ. Human in vivo pharmacology of topical retinoids. *Arch Dermatol Res* 1994; 287:53–60.
- Fisher GJ, Datta SC, Talwar HS, et al. Molecular basis of sun-induced premature skin ageing and retinoid antagonism. *Nature* 1996; 379:335–339.
- Fisher GJ, Wang ZQ, Datta SC, et al. Pathophysiology of premature skin aging induced by ultraviolet light. *N Engl J Med* 1997; 337(20):1419–1428.
- Rask L, Anundi H, Böhme J, et al. The retinol-binding protein. *Scand J Clin Lab Invest* 1980; 154:45–61.
- Båvik CO, Peterson A, Eriksson U. Retinol-binding protein mediates uptake of retinol to cultured human keratinocytes. *Exp Cell Res* 1995; 216:358–362.
- Hinterhuber G, Cauza K, Brugger K, et al. RPE65 of retinal pigment epithelium, a putative receptor molecule for plasma retinol-binding protein, is expressed in human keratinocytes. *J Invest Dermatol* 2004; 122:406–413.
- Huang J, Vieira A. Evidence for a specific cell membrane retinol-binding protein transport mechanism in a human keratinocyte line. *Int J Mol Med* 2006; 17:627–631.
- Kang S, Duell EA, Fisher GJ, et al. Application of retinol to human skin in vivo induces epidermal hyperplasia and cellular retinoid binding proteins characteristic of retinoic acid but without measurable retinoic acid levels or irritation. *J Invest Dermatol* 1995; 105:549–556.
- Antille C, Tran C, Sorg O, et al. Penetration and metabolism of topical retinoids in ex vivo organ-cultured full-thickness human skin explants. *Skin Pharmacol Physiol* 2004; 17:124–128.
- Törmä H, Vahlquist A. Vitamin A esterification in human epidermis: a relation to keratinocyte differentiation. *J Invest Dermatol* 1990; 94:132–138.
- Yin SJ, Han CL, Lee AI, et al. Human alcohol dehydrogenase family. Functional classification, ethanol/retinol metabolism, and medical implications. *Adv Exp Med Biol*, 1999; 463:265–274.
- Roos TC, Jugert FK, Merk HF, et al. Retinoid metabolism in the skin. *Pharmacol Rev* 1998; 50:315–333.
- Wolbach SB, Howe PR. Tissue changes following deprivation of fat soluble A vitamin. *J Exp Med* 1925; 42:753–777.
- Frazier CN, Hu CK. Cutaneous lesion associated with Vitamin A deficiency in man. *Arch Intern Med* 1931; 48:507–514.
- Chapellier B, Mark M, Messaddeq N, et al. Physiological and retinoid-induced proliferations of epidermis basal keratinocytes are differently controlled. *EMBO J* 2002; 21:3402–3413.
- Rittié L, Varani J, Kang S, et al. Retinoid-induced epidermal hyperplasia is mediated by epidermal growth factor receptor activation via specific induction of its ligands heparin-binding EGF and amphiregulin in human skin in vivo. *J Invest Dermatol* 2006; 126:732–739.
- Varani J, Warner RL, Gharraee-Kermani M, et al. Vitamin A antagonizes decreased cell growth and elevated collagen-degrading matrix metalloproteinases and stimulates collagen accumulation in naturally aged human skin. *J Invest Dermatol* 2000; 114:480–486.
- Kligman AM, Fulton JE Jr, Plewig G. Topical vitamin A acid in acne vulgaris. *Arch Dermatol* 1969; 99:469–476.
- Kligman LH, Kligman AM. The nature of photoaging: its prevention and repair. *Photodermatol* 1986; 3:215–227.
- Weiss JS, Ellis CN, Headington JT, et al. Topical tretinoin in the treatment of aging skin. *J Am Acad Dermatol* 1988; 19:169–175.
- Lever L, Kumar P, Marks R. Topical retinoic acid for treatment of solar damage. *Br J Dermatol* 1990; 122:91–98.
- Grove GL, Grove MJ, Leyden JJ, et al. Skin replica analysis of photodamaged skin after therapy with tretinoin emollient cream. *J Am Acad Dermatol* 1991; 25:231–237.
- Olsen EA, Katz HI, Levine N, et al. Tretinoin emollient cream: a new therapy for photodamaged skin. *J Am Acad Dermatol* 1992; 26:215–224.
- Effendy I, Weltfriend S, Patil S, et al. Differential irritant skin responses to topical retinoic acid and sodium lauryl sulphate: alone and in crossover design. *Br J Dermatol* 1996; 134:424–430.
- Duell EA, Kang S, Voorhees JJ. Unoccluded retinol penetrates human skin in vivo more effectively than unoccluded retinyl palmitate or retinoic acid. *J Invest Dermatol* 1997; 109:301–305.
- Goffin V, Henry F, Piérard-Franchimont C, et al. Topical retinol and the stratum corneum response to an environmental threat. *Skin Pharmacol* 1997; 10:85–89.
- Kafi R, Kwak HS, Schumacher WE, et al. Improvement of naturally aged skin with vitamin A (retinol). *Arch Dermatol* 2007; 143:606–612.
- Bellemère G, Stamatias GN, Bruère V, et al. Antiaging action of retinol: from molecular to clinical. *Skin Pharmacol Physiol* 2009; 22:200–209.
- Tucker-Samaras S, Zedayko T, Cole C, et al. A stabilized 0.1% retinol facial moisturizer improved the appearance of photodamaged skin in an eight week, double blind vehicle controlled study. *J Drug Dermatol* 2009; 8:1–5.
- Cho S, Lowe L, Hamilton TA, et al. Long-term treatment of photoaged human skin with topical retinoic acid improves epidermal cell atypia and thickens the collagen band in papillary dermis. *J Am Acad Dermatol* 2005; 53:769–774.

## Applications of total soy in skin care

Jue-Chen Liu, Jeff Wu, and Miri Seiberg

### INTRODUCTION

The soybean plant belongs to the “pea” family, Leguminosae, subfamily Papilionoideae, and the genus *Glycine*, L. The cultivated form is named *Glycine max* (L.) Merr. It is one of the oldest annual crops of the Far East. Dietary soy has been known for centuries to provide nutritional, medicinal and health benefits. Because of the nutritional value of soybeans, there is an inherited value for skin care applications. In fact, the use of soy to treat skin conditions has long history. It was first reported in *Traditional Chinese Medicine Encyclopedia* (1) that soybeans provided therapeutic efficacy against skin conditions including hyperpigmented lesions and dry skin. Additionally, Chinese folklore has that women workers in tofu industries have the most beautiful skin, that is, fair, smooth and porcelain-like fine skin. For a very long time, soy or components of soy for topical applications has been limited to functional applications such as emollient agents, skin conditioning agents. The scientific fundamentals and clinical efficacy of soy for skin benefits have not been proven until recent years. It was reported that soy isoflavones possess phytoestrogenic properties which may play a role in the skin of menopausal women (2). Specific protein components in soybeans were identified for inhibition of melanosome transfer resulting in pigment reduction (3–5). Other soybean components such as lipids, oligosaccharides, saponins can also provide skin benefits. Such new knowledge and findings have been implemented into dermatological and cosmeceutical products for broader skin applications. This chapter will review the components of soy and their clinical uses in improving skin conditions.

### SOY IN HUMAN HEALTH

Soybeans originate from China. In 2853 BC, Emperor Sheng-Nung of China named five sacred plants—soybeans, rice, wheat, barley, and millet. Soybean plants were then domesticated and cultivated into a food crop for everyday diet (6,7). The soybean has blossomed from legendary Chinese origins to the “miracle crop” vastly produced on modern-day American farms since its first introduction into the United States in the early 1800s (7).

From about the first century AC to the Age of Discovery (15th and 16th centuries), soybeans were introduced into several countries such as Japan, Indonesia, the Philippines, Vietnam, Thailand, Malaysia, Burma, Nepal, and India. The first soybeans arrived in America in the early 1800s and since then have played an increasingly important role for both human nutrition and health.

Soybeans with their valuable proteins and oil are an important source of nutrition. The soybean is rich in minerals including calcium, iron, and potassium, amino acids and vitamins. It is also a good fiber source (8,9). They can be used

as meat and dairy substitutes in various items. Today, most people are aware of the use of soy proteins in baby formula, weight-loss drinks, sport drinks and as a low-fat substitute for hamburger. Soybeans are also valued for their medicinal qualities. Epidemiological data indicates that people from Asian cultures have lower rates of certain cancers, including cancers of breast, prostate, colon, cardiovascular disease, osteoporosis and postmenopausal symptoms (10–16). Over the last decade, studies on soy’s health benefits have dramatically increased in these areas and more systematic and controlled clinical studies were presented on these health benefits (17,18). Consequently, the Food and Drug Administration (FDA), authorized in 1999, the use of soy protein, on food labels of health claims on the association between soy protein and reduced risk of coronary heart disease (19). This ruling is based on the FDA’s decision that foods containing soy protein included in a diet low in saturated fat and cholesterol may reduce the risk of coronary heart disease by lowering blood cholesterol levels.

### EARLY UTILIZATION OF SOY IN TOPICAL APPLICATION

For many years, because of the lack of basic research in understanding the fundamental mechanisms of soy on skin, soy’s nutritional components were used mainly as functional ingredients in the cosmetic industry (20) and mostly remain so until today. Most frequently used soy components include soybean oil, soy protein isolates, soy lecithin and soy sterols as noted in Table 15.1. Soybean oil is one of the valuable materials to adjust the rheology of cosmetic emulsions. Examples of soy oil as an emollient and moisturizer include products of baby oil and moisturizing lotion. Soy protein isolate/hydrolysate has been formulated as an emulsifier and foaming enhancers into a wide variety of products including laundry detergents, bath products, shampoos and skin cleansers (21). The lecithin fraction of crude soybean oil found application as an emulsifying, surface-active agent, and stabilizing agent in industrial products such as paint, ink, soap and cosmetics (22). Soy sterols are employed as skin conditioners for lotion, cream and cleanser (23).

Since the early of 1990s, soy extracts or soy germ extracts that claimed to provide specific biological activities started to appear in the skin care products. These soy extracts, although defined vaguely as soy (soja) concentrates or soy proteins, were actually produced using different chemical extraction conditions and could result in dissimilar compositions and skin effects. Such soy extracts often had too small fraction amount of the original soy components to provide desired biological activities or were processed excessively under harsh extraction conditions such as extreme pHs, strong solvents, elevated temperature to keep the bioactivities for skin efficacy. Little clinical reports or publications were available for the cosmetic

**Table 15.1** Traditional Use of Soy in Skin and Hair Care

Soy components	Functionality	Applications	Reference
Soybean oil	Skin conditioner/emollient	Baby oil, moisturizer	22
Soy protein isolate/hydrolyzate	Emulsifier	Bath products, cleansers, shampoos	21
Soy lecithin/phospholipids	Surface active, emulsifier, stabilizing agent	Liposome	42
Soy sterol	Skin conditioner	Lotion/cream/cleanser	20

products spiked with such soy extracts. The use of these soy extracts has been limited to product's marketing claims.

### RECENT SCIENTIFIC ADVANCES IN TOTAL SOY Nondenatured Soy Proteins and Depigmentation

There is an increasingly need for skin care products to achieve fair skin for pigmented populations, as well as even tone skin by reducing hyperpigmentations including mottled hyperpigmentation, solar lentigines, and melasma for global population. The most frequent used topical treatment agents for depigmentation are tyrosinase inhibitors, hydroxyacids, retinoids, hydroquinones, anti-inflammatory agent and the combinations. Treatment with these agents may result in irritation, sun sensitivity, toxicity, or performance disappointment (24). In its proposal published in the U.S. government's Federal Register, The FDA notes, "The actual risk to humans from use of hydroquinone has yet to be fully determined. . . . We're acting for safety reasons. There is a potential for hydroquinone to be a carcinogen in humans."

Therefore, safer and more effective depigmenting agents are needed. Moreover, a move toward "green" therapies has led to a demand for a natural, safe and efficacious skin-lightening agent.

Soybeans contain two major proteins, which are reported to inhibit protease-activated receptor 2 (PAR-2) pathway, leading to reduced melanosomes transfer from melanocyte to keratinocyte resulting in pigmentation reduction. These two proteins are serine proteinase inhibitors: the Kunitz-type trypsin inhibitor [soybean trypsin inhibitor (STI)], and the Bowman-Birk inhibitor (BBI) (25,26). STI has a molecular weight of 20 kd and consists of 181 amino acid residues with two disulfide bridges and is roughly spherically shaped (27). BBI is an 8-kd protein that inhibits the proteases trypsin and chymotrypsin at separate reactive sites (28–30). PAR-2 is a G protein-coupled receptor activated by a serine protease cleavage. Trypsin and mast cell tryptase are the only known natural serine proteases that activate PAR-2 (31,32). PAR-2 is expressed in keratinocytes (33,34), but not in melanocytes (3) and is involved in the regulation of pigmentation (3,35,36). It was reported that that the inhibition of PAR-2 activation by serine protease inhibitors results in reduced pigment deposition. This effect is possible only when keratinocyte-melanocyte contact is established (Fig. 15.1, top panel). Melanocytes alone do not respond to PAR-2 modulating agents with pigmentary changes (3). When serine protease inhibitors interfere with PAR-2 activation, melanosome transfer from the melanocytes to the keratinocytes is inhibited. The reduced melanosome ingestion by keratinocytes results in depigmentation both *in vitro* and *in vivo* (3,36). This depigmenting effect caused by serine protease inhibitors is reversible *in vivo* (3,36), therefore excluding the possibility of melanocyte death following such treatments.

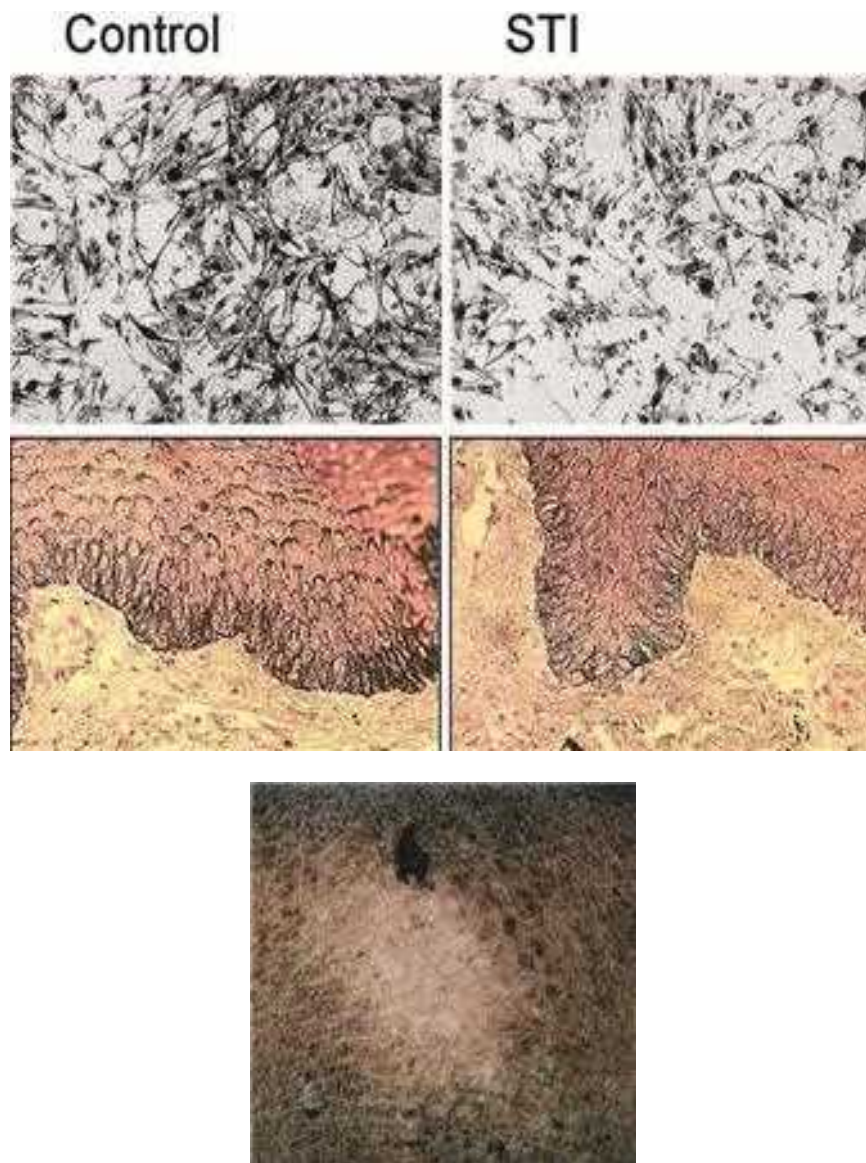
Most activities of STI and BBI in soy foods are denatured by heat or fermentation to prevent blocking the trypsin activity in the gut resulting in gastrointestinal adverse effects.

It was found that nondenatured soybean extracts, that is, Total Soy, and the isolated soy-derived proteins STI and BBI, inhibit PAR-2 activation, resulting in skin depigmentation (5). As shown in Figure 15.1, keratinocyte-melanocyte cocultures treated with the soy protein STI have reduced tyrosinase activity, documented by L-3,4 dihydroxyphenylalanine (DOPA) staining (upper panel). Hyperpigmented human skin, grafted on immunodeficient mice, and treated with STI, showed reduced pigment deposition, demonstrated by Fontana-Mason (F&M) staining of histological sections after five weeks of treatment (middle panel). F&M staining identifies silver nitrate reducing molecules. In skin, this nonspecific stain identifies primarily melanin. Dark-skinned swine treated with a nondenatured soy extract (Total Soy) demonstrates visible skin lightening following eight weeks of treatment (lower panel). Therefore, agents such as STI, BBI or nondenatured soybean extracts (Total Soy) may serve as alternative, natural treatments for skin lightening or hyperpigmentation.

### Total Soy and Delayed Hair Growth

The mammalian hair provides environmental protection, but this function has been lost in humans, who keep or remove their hair at different body locations for social and cosmetic purposes. Many procedures are used to remove unwanted hair, ranging from simple and inexpensive treatments like shaving, to costly and time-consuming methods as electrolysis and laser therapies. Hair removal methods differ in the duration of the effect, in their pain and discomfort levels, and in their possible undesired side effects (37).

The hair follicle undergoes cycles of active growth (anagen), regression (catagen), and rest (telogen) (38). While the morphological changes throughout the hair cycle are well documented (39), the regulation of the different phases of this cycle is not completely understood. It was recently demonstrated that nondenatured soybean extracts (Total Soy), and the soybean derived proteins STI and BBI reduce not only hair pigmentation, but also the rate of hair growth and the final dimensions of the hair shaft (4). Following Total Soy treatment the onset of anagen was delayed, the duration of the hair cycle was reduced, and the resulting hair shafts were shorter, thinner and softer. As shown in Figure 15.2, mouse hair treated with a nondenatured soy extract or Total Soy showed reduction in the length of the hair shafts (upper panel). Hair follicle development (anagen) was delayed as seen following seven days of treatment (middle panel). While the untreated follicles were completely developed, at this time point the soy-treated follicles were smaller and contained reduced levels of pigment. At day 15 of the treatment, when all follicles had reached their final dimensions, the soy-treated follicles were significantly smaller (lower panel). While it appears that the soy isoflavones may play some role in the delayed hair growth by Total Soy lotion, Total Soy products' ability to thin the hair and facilitate less frequent hair removal seems to result primarily from the



**Figure 15.1** Illustrates that the inhibition of protease-activated receptor 2 activation by serine protease inhibitors results in reduced pigment deposition. Keratinocyte-melanocyte cocultures treated with the soy protein STI have reduced tyrosinase activity, documented by DOPA staining (*upper panel*). Hyperpigmented human skin, grafted on immuno-deficient mice, and treated with STI, showed reduced pigment deposition, demonstrated by F&M staining of histological sections after five weeks of treatment (*middle panel: left, control; right, STI*). Dark-skinned swine treated with a nondenatured soy extract demonstrates visible skin lightening following eight weeks of treatment (*lower panel*). *Abbreviation:* STI, soybean trypsin inhibitor.

actions of two soy-derived proteins: STI and BBI (5). The results indicate that agents such as nondenatured soy extracts or Total Soy may serve as an inexpensive, natural alternative treatment for undesired hair growth.

## TOTAL SOY FOR COSMETIC DERMATOLOGY APPLICATIONS

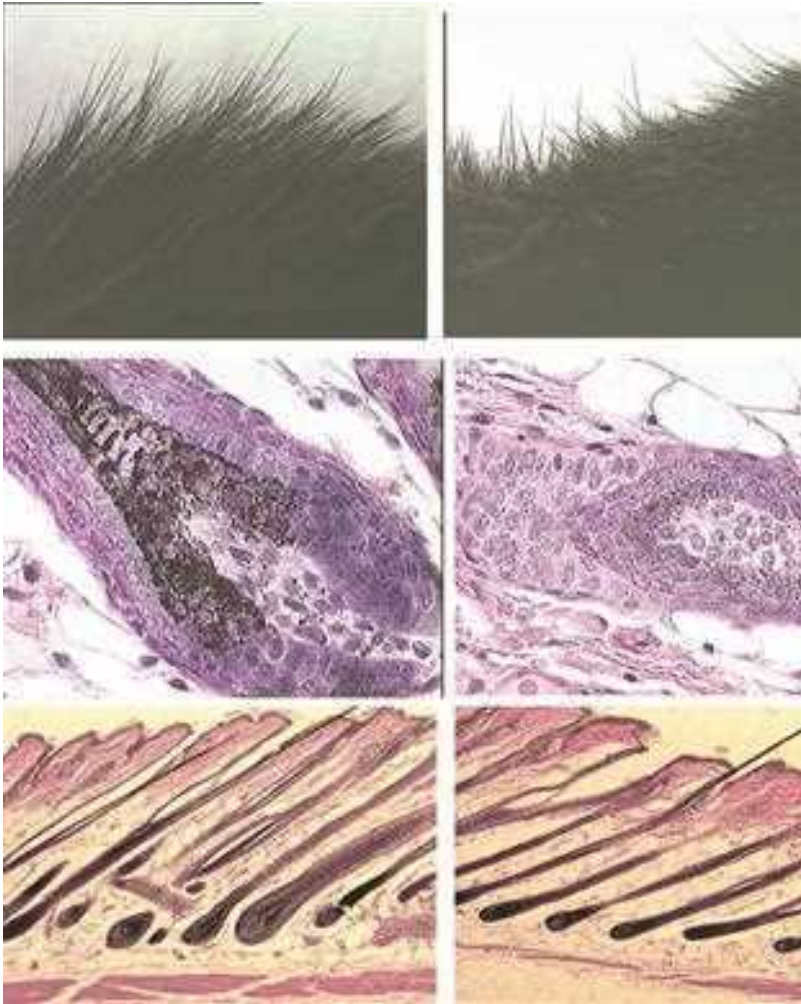
### Total Soy Composition

While the compositions of natural soybeans can be inevitably subject to variations, depending on the particular harvest, soil/region, and species variation, the basic chemical composition is

illustrated in Table 15.2 (40, USDA database). Mature soybeans can compose of up to 36% proteins, 30% carbohydrates and 20% lipids. A highly innovative Total Soy technology derived from soybeans was created on the basis of the scientific findings. Total Soy raw material is created without using neither chemicals nor chemical solvents. The standardization of the manufacturing process leaves a blend of balanced nondenatured components including active proteins, essential lipids, oligosaccharides, etc., which are in a similar proportion to that naturally present in the soybeans.

Table 15.3 illustrates the Total Soy components with potential applications in skin care. First, Total Soy contains both small





**Figure 15.2** Shows the images of hair growth patterns under different conditions. Reduction in the length of the mouse hair shafts treated with a nondenatured soy extract (*upper panel*). A delayed hair follicle development (anagen) as seen following seven days of treatment (*middle panel*). While the untreated follicles were completely developed, at this time point the soy-treated follicles were smaller and contained reduced levels of pigment. At day 15 of the treatment, when all follicles had reached their final dimensions, the soy-treated follicles were significantly smaller (*lower panel*).

**Table 15.2** Soybean Composition Characteristics

Major components	Green/raw percent wt/wt	Mature seeds percent wt/wt
Water	67	8
Proteins	12	36
Lipids	6	19
Carbohydrates	11	29
Fiber	4	8

Source: From Ref. 40.

and large soy proteins. The small soy proteins include protease inhibitors such as Kunitz trypsin inhibitors, Bowman-Birk trypsin inhibitors, and lunasin. The bioactivity relating to novel pigmentation inhibition is retained (3,4). Unlike trypsin inhibitors of protein natures, the nonprotein trypsin inhibitors lack specificity and are very susceptible to cationic suppression (41). The large proteins include hundreds of proteins with varying molecular weight up to millions Daltons. The most abundant proteins are glycinin and conglycinin with molecular weight around 180 and 360 kd (42). Each protein group precipitates at different pH values, which may affect topical formulation preparations. Second, Total Soy contains essential fatty acids including linoleic acid and linolenic acids, which are essential to help

stratum corneum restore barrier functions, and potentially help acne resolution. These unsaturated fatty acids may also provide antioxidant properties (43). In addition, linoleic acid is known to enhance skin penetration of various compounds (44). Crude soybean oil contains 1% to 3% phospholipids, which is the major components of cell membranes (45). Phospholipids can also form liposome, a vesicle delivery system to enhance skin penetration for both hydrophilic and lipophilic, large molecules such as proteins and small such as  $\alpha$ -hydroxy acids. Total Soy contains about 30% carbohydrates, which can provide skin hydration properties.

Total Soy also contains the following minor components offering important skin care benefits.

- Soy isoflavonoids: Isoflavones have been reported to provide a number of skin care benefits. Isoflavones have weak antioxidant and anti-inflammatory activities, which are important to combat oxidative stresses induced in the sun. A number of studies indicated isoflavones can prevent and treat sun-induced cancer (46,47). Isoflavones such as genistein and daidzein, normally classified as phytoestrogens, originate in plants; unlike estrogens, which are of animal origin. The isoflavone structures are nonsteroidal, while all estrogenic hormones are steroidal (48,49).

**Table 15.3** Total Soy Components with Potential Applications in Skin Care

Soy components	Skin care applications	References
<i>Proteins 30–50%</i>		
Small soy proteins (soybean trypsin inhibitor, Bowman-Birk protease inhibitors, lunasin)	Depigmenting and delay hair growth	3–5,32,33,45
Large soy proteins (e.g., glycinin 360 kd, β-conglycinin 180 kd)	Skin softening and smoothing	42
<i>Lipids 10–30%</i>		
Essential fatty acids (linoleic, linolenic, oleic acids)	Antioxidant protection, skin lightening, restore barrier function	42–44
Lecithins/phospholipids	Skin moisture, cleansing	42
<i>Carbohydrates</i>		
Di- and oligosaccharides and polysaccharides	Skin hydration	42
<i>Minor Components</i>		
Soy isoflavones (e.g., daidzein, genistein, daidzin, genistin)	Weak antioxidant and anti-inflammatory, inhibition of tyrosine	46–49
Phytosterols	Skin moisture, anti-inflammatory	50,51
Vitamins (tocopherols)	Antioxidant	42
Minerals	Deficiency can cause undesired skin problems such as dermatitis, discoloration of hair and retardation of hair growth	53
<i>Others</i>		
Saponins	Cleansing	42,54
Phytic acid	Depigmentating	42

- **Phytosterols:** Soybean oil can contain as much as 0.37% of phytosterols, which are mostly in unsaponifiable forms (50). The most significant phytosterols found in oils and fats are campesterol, stigmasterol, β-sitosterol, δ-5-avenasterol and δ-7-stigmasterol. Phytosterols is reported to provide anti-inflammatory effects via the arachidonic cascade. Clinical applications can be found for antipruritic effects, reducing sun-induced erythema and diaper dermatitis (50,51). Such characteristics combined with the conditioner use makes them possible alternatives to the use of cortisone and corticosteroids, as well as silicones replacement.
- **Vitamins:** Soybeans contain both water and oil-soluble vitamins. The water-soluble vitamins present in soybeans mainly include thiamin, riboflavin, niacin, pantothenic acid and folic acid. The oil-soluble vitamins found in soybeans are vitamin A and E. Soybean oil contains a substantial amount of vitamin E, which provides effective natural antioxidant and nutrition values (52).
- **Minerals:** Metal ions play important role in skin health. Deficient in certain metal ions in the skin will results in untoward effects such as dermatitis, discoloration of hair, and retardation of hair growth. Optimal metal ions such as manganese, magnesium, calcium and zinc are needed to maintain skin health (53). Soy contains relatively high levels of desired metal ions such as iron, zinc, manganese, magnesium, and calcium, that essential in skin health.
- **Others:** The soy saponins (2,3-dihydro-2,5-dihydroxy-6-methyl-4H-pyran-4-one) contain carboxyl groups, which have surface activity for foaming and emulsifying power in cosmetic formulation (54), and also reported to provide active oxygen-scavenging effect in the skin and maintain healthy epidermal conditions (55).

**Safety of Total Soy for Human Topical Applications**

It is known that some naturally derived ingredients can elicit irritant or allergic responses. Soy has been used for centuries and is well known to be safe for human use. A systematical safety evaluation has been completed to determine the clinical

topical profiles of the Total Soy raw material ingredients and the Total Soy containing skin care formulations (56). Clinical cumulative irritation evaluations utilized two different methodologies that consisted of patching the subject with the formulation over a two- to three-week time period. The first method was conducted to assess irritancy, in which a minimum of 25 subjects was patched continuously for a total of six applications over a two-week period. The second method was conducted to assess comparative irritation potential of the formulations, in which approximately 200 subjects were patched intermittently with the formulation three times a week for a total of nine applications over a three-week period. All test sites were graded three times a week after patch removal. In a potential total irritation score of 660, both Total Soy ingredient and all skin care formulations with soy resulted in negligible cumulative irritation score <10. Comparative cumulative irritation of Total Soy formulas also demonstrated negligible irritation. Total soy formulations were clinically evaluated with the repeated insult patch test (RIPT). These studies demonstrated that specific topical formulations containing the Total Soy alone, soy extract, soy extraction in combination with vitamins A and C did not cause contact dermal sensitization. Photosensitivity was also assessed by photoallergy and phototoxicity, which did not find any photosensitivity when Total Soy was applied.

Recently, soy isoflavones have drawn significant attention for their potential phytoestrogenic effects. Soy isoflavones differ significantly in terms of their molecular structure from estrogens, such as estradiol, and are not metabolized to these estrogens. Experimental data suggests that isoflavones exhibit an estrogenic like potency of between 1000 and 100,000 times lower than estradiol, depending on the nature of the assay used (57–59). Largely as a result of research in in vitro or in animal models, concerns have been voiced regarding isoflavones in the use of isoflavone containing soy products, for example, soy infant formulas in relation to nutritional adequacy, sexual development, neurobehavioral development, immune function, and thyroid disease. Available evidence from adult human and infant populations indicates that dietary isoflavones in soy infant formulas do not adversely affect human growth,

development, or reproduction (60). There is no research showing that soy extract or soy oil has estrogenic effects when applied to skin, as it might when taken orally at high doses (61).

The Total Soy products contain typically less than 0.01% soy isoflavones. A placebo-controlled in vitro dermal absorption study using human cadaver skin has found that the potential systemic soy isoflavones absorption from topical applications of such Total Soy products is below the detection limits of the current state of art analytical instrumentation and negligible comparing with any endogenous levels of isoflavones resulted from dietary soy consumptions or supplement consumptions of infant soy milk. The potential local epidermal and dermal accumulations for soy isoflavones are estimated to be at least 2500 times lower than the NOAEL limit. In summary, soy isoflavones are naturally occurring in Total Soy and they exist at trace levels. Their potential systemic absorption is negligible and presents no harmful risks to human health at all.

**In Vitro and Preclinical Results of Total Soy**

Nondenatured soy has been found to show multiple bioactivities including trypsin-inhibitory activity, stimulating collagen and elastin production, anti-inflammatory, antioxidant, antistress/thiol retention and anti-ultraviolet (UV)B damage activity.

*Trypsin-Inhibitory Activity of Total Soy*

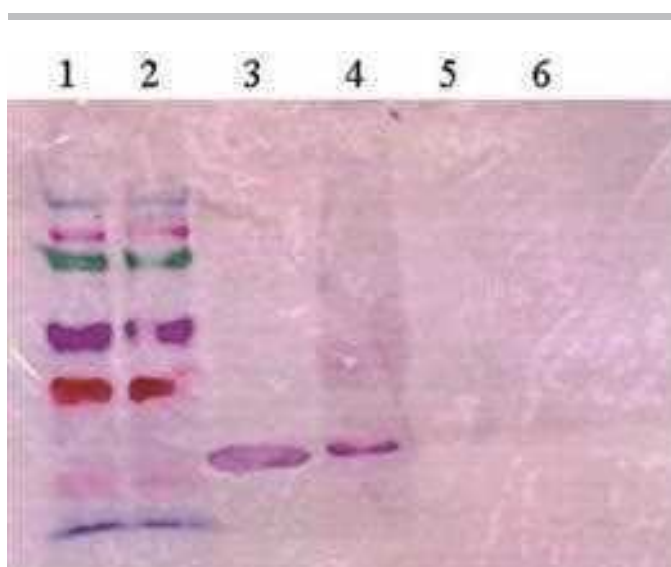
Soy preparations containing various levels of nondenatured soymilk resulted in a dose-dependent inhibition of trypsin activity, measured by an in vitro fluorescence assay. A stabilized soy formulation containing nondenatured soy protein STI was developed (62). The stability of the STI was monitored by enzyme inhibition assay and Western Blot. The results illustrate that the soy formulation retained the serine protease inhibitory activity. The STI protein was shown to be intact by Western blot analysis after one year at room temperature (Fig. 15.3).

*Collagen Production*

Preclinical studies of a Total Soy composition were investigated for the in vitro collagen production via monitoring normal human dermal fibroblast synthesis method. Table 15.4 shows that Total Soy could stimulate collagen synthesis (63,64). For a Total Soy concentration as low as 0.01 mg/mL, the increase rate in the fibroblasts was found to be 33% after 72 hours of Total Soy action at 37°C in a humidified atmosphere.

*Elastin Enhancement*

The treatment with Total Soy was evaluated preclinically for elastin synthesis by elastin staining on swine subjects (63). The histological analysis from these elastin evaluations demonstrates an increase in fine and highly branched elastin fibers for Total Soy composition applications, as shown in Figure 15.4, suggesting the capability of Total Soy to enhance skin elasticity, while providing other skin care benefits such as even tone and texture.



**Figure 15.3** Displays the Western blots comparing a nondenaturing soy (Total Soy) product versus a soy product using a single soy component. According to Western blot analysis, the STI protein was compromised for soy products using a single soy component. The STI protein was intact after one year at room temperature for the Total Soy preparation. 1, 2: size markers; 3, STI marker; 4, Ess-23; 5, Ess-23 placebo; 6, Future White Essence HR. *Abbreviation:* STI, soybean trypsin inhibitor.

Swine studies with the application of Total Soy composition, twice a day, five days/week, for nine weeks showed no visual irritation, and histological analyses revealed no markers of irritation or other pathological signs. Sections from biopsies were stained with Luna stain, to document elastin fibers. At least three sections per biopsy, two sites per swine were processed. Each experiment was repeated at least three times. Histological analysis of Luna-stained sections demonstrates an increase in fine and highly branched elastin fibers at the upper part of the dermis, following soy treatments as displayed, for example, in Figure 15.4. This increase in elastin staining resembles a “repair zone,” as documented for the effect of retinoids on UV-damaged skin (65).

Mouse and swine skins topically treated with soybean extracts showed enhanced elastic fiber network and increased desmosome content (66). Elastin expression was also augmented in human skin transplanted onto severe combined immunodeficiency (SCID) mice in response to soy treatment.

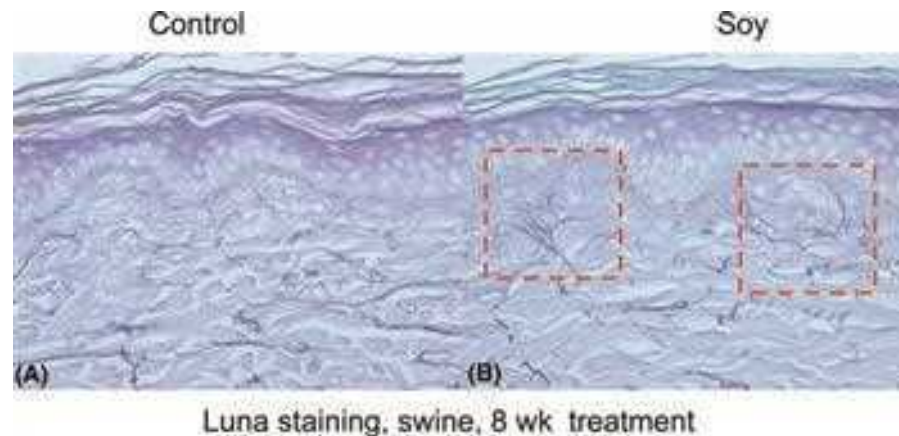
Elastic fibers are essential extracellular matrix components of the skin, contributing to its resilience and elasticity. In the course of skin ageing, elastin synthesis is reduced, and

**Table 15.4** Effect of Total Soy Complex on Extracellular Collagen Synthesis in Normal Human Dermal Fibroblasts

	Total Soy (µg/mL)			
	Control	0.01	0.1	1
Collagen synthesis (dpm/cell) × 1000 <sup>a</sup>	11.26 ± 1.62	15.0 ± 1.46	13.68 ± 2.51	17.80 ± 2.01
Stimulation		NS	NS	p < 0.05
		+33%	+21%	+58%

<sup>a</sup>dpm, disintegration per minute, a unit measuring radioactivity level. The collagen synthesis assay uses a radioactive precursor and measures radioactivity of the collagen product.

*Abbreviation:* NS, nonsignificant.



**Figure 15.4** Histological analysis of Luna-stained sections demonstrates an increase in fine and highly branched elastin fibers (*red squares*) at the upper part of the swine dermis, following soy treatments as displayed. (A) Before and (B) after eight weeks' treatment.

elastase activity is accelerated, resulting in skin sagging and reduced skin elasticity. It was found that that nondenatured Glycine max (soybean) extracts induced elastin promoter activity, inhibited elastase activity and protected elastic fibers from degradation by exogenous elastases *in vitro*.

#### *Anti-Inflammatory and Antioxidant Activities*

The nondenatured soy extract was found to be active against the acute oxazolone application on mouse ear edema (67). Oxazolone was used to induce contact hypersensitivity or edema in mice ear and the inhibition of edema was used to determine the degree of anti-inflammation activity. The studies showed that a 2% Total Soy lotion has about 56% edema inhibition versus 8% edema inhibition for its placebo control, as a comparison, 0.1% hydrocortisone had an inhibition of 86%. The nondenatured Total Soy extract was also found to have a reasonable degree of antioxidant activity.

#### *Antistress/Thiol Retention Activity*

Total Soy was found to have the activity in maintaining the normal cell metabolism, even when exposed to a harsh environment, such as environmental pollution, for example, smoke-induced loss of thiols (68).

The ability of Total Soy to prevent smoke-induced loss of thiols was evaluated in normal human dermal fibroblasts (Clonetics, San Diego, California, U.S.). Thiols, chiefly glutathione, are part of the endogenous cellular antioxidant defense system. Glutathione serves as a redox buffer, thereby, maintaining the balance between oxidants and antioxidants (69). Glutathione is also the preferred substrate for several enzymes such as the glutathione peroxidases (decomposing peroxides) and the glutathione-S-transferases (a major group of detoxification enzymes) (70).

Cutaneous antioxidants (both enzymatic and nonenzymatic), including glutathione, are depleted after UV or ozone exposure (71,72). In cell culture models, low intracellular glutathione (GSH) levels lead to a higher UV radiation sensitivity. Glutathione is a major endogenous antioxidant, highly responsive against environmental challenges, able to regulate the tone and the wrinkling of skin, as well as treat external aggression.

**Table 15.5** Thiol Retention Activity Measurement for Total Soy

Environmental stress	Total Soy complex concentration (weight percent)	Thiol retention activity percent <sup>a</sup>
No smoke	0	100 ± 6.71
Smoke (10 min)	0	65.38 ± 7.16
	0.5	91.24 ± 14.25
	1	95.39 ± 4.52
	2	106.92 ± 17.06

<sup>a</sup>Thiol retention activity percent [percent thiols contained in no-smoke group; mean ± standard error of the mean (SEM)].

The effects of Total Soy in preventing smoke-induced stress are displayed in Table 15.5. The results indicate that Total Soy afforded a protection against smoke-induced loss of thiols or thiol retention activity (data represent the mean ± standard error of the mean for replicates from three independent experiments). "Thiol retention activity" means the ability of the Total Soy at a concentration of 1% (w/v) to inhibit smoke-induced loss of thiols, as measured by the above assay.

#### *Reduction in UVB-Induced Skin Damages*

The incidence of nonmelanoma skin cancers is increasing, and agents that can prevent or reduce UVB-induced skin cancer are desired. BBI protein is a known cancer suppressive agent that is effective in many different species, in different organs and tissues, and when given via different routes of administration (26). Recent studies showed that pretreatment with nondenatured soy extracts, BBI and STI proteins reduced UVB-induced skin tumor formation and progression in high-risk hairless mice with low dose of UVB pretreatment for a long time (73). In contrast, denatured soy extracts were found to have no effects on the skin tumor formation and progression. The multiple mechanisms of action were also identified for nondenatured soy.

- *In vitro*, nondenatured soy extracts enhanced UVB-induced checkpoint kinase 1 (Ck-1) activation, suggesting a delay in cell cycle progression that enables longer time for DNA repair.

- Denatured soy displays anti-inflammatory activity via reduced UVB-induced cyclo-oxygenase-2 (COX-2) expression and prostaglandin E2 secretion, and inhibited p-38 MAP kinase activation. Mice pretreated topically with denatured soy extracts had reduced levels of UVB-induced TT dimmers and COX-2 expression in their skins compared with UVB alone.
- Nondenatured soy extracts also inhibited vascular endothelial growth factor-induced endothelial tube formation in Matrigel, suggesting a possible inhibitory effect on angiogenesis and tumor progression.

All the learning so far suggest that topical application of nondenatured soy extracts could potentially reduce the incidence of skin cancer, via multiple molecular mechanisms, at both the tumor initiation and tumor progression stage (74).

### CLINICAL EFFICACY OF TOTAL SOY Reduction of Hyperpigmented Spots

A stabilized Total Soy formulation containing STI was tested on a Caucasian men population with solar lentigine hyperpigmented lesions (75). The effect of stabilized Total Soy formulation was

compared with 15% azelaic acid and 12% glycolic acid. After three weeks of once-daily treatment, the pigmented lesions were significantly lightened. The effect of stabilized Total Soy formulation is comparable to or better than either to 15% azelaic acid or 12% glycolic acid according to dermatological grading. In another open-label clinical study on a Caucasian population with various types of pigmented lesions, the stabilized Total Soy formulation was found to improve 78% tested subjects in dermatological grading (Fig. 15.5).

### Reduction of Ultraviolet-Induced Damages

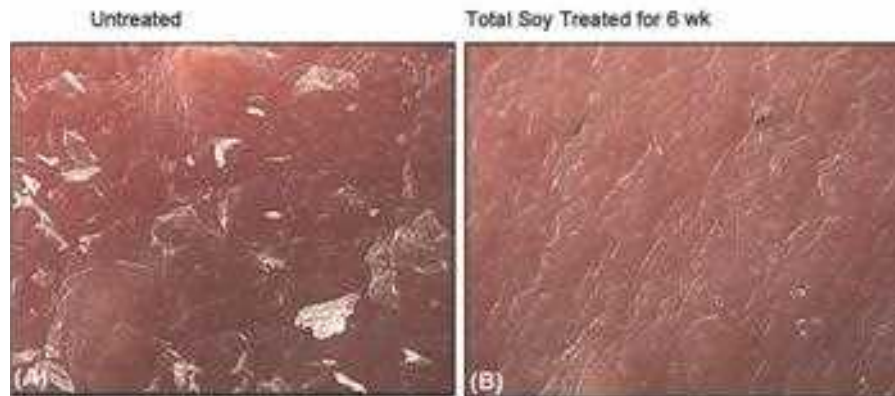
Other benefits proven include reducing UV-induced erythema/flakiness (Fig. 15.6) (76,77). On the basis of the preclinical learning of soy in preventing UV-induced pigmentation, a topical soy essence was developed using Total Soy extracts. The soy essence was tested in a placebo-controlled clinical study on types I and III skin with 0.8- to 2-MED UV irradiation. Both pretreatment and post treatment were performed on six different subjects each for five consecutive days. Evaluation techniques employed to determine the effect of Total Soy essence on the irradiation included visual clinical assessment,

### SOY Lightens Dark Marks



**Figure 15.5** A Total Soy formulation containing soybean trypsin inhibitor was tested on a female population with hyperpigmented lesions ( $n = 42$ ). After eight week of once-daily treatment on the selected lesions, the pigmented lesions were significantly lightened, thereby evening the appearance of skin tone. (A) Baseline and (B) after eight weeks of once-a-day application to Middle East skin type IV female.

### Total Soy reduced Sun-Induced Damages



**Male subject, 4 wk once a day treatment**

**Figure 15.6** A Caucasian male volunteer treated half of his face with Total Soy once daily for six weeks followed by an eight-hour exposure. The measurement was conducted at 24 hours post exposure: (A) before and (B) after.

diffused reflectance spectroscopy, photo imaging and desquamation taping. The observation was made at 24-hour and seven-day time point. Dermatologist's clinical assessment displayed that an immediate application of soy essence reduced redness induced by UV irradiation at 0.8 to 1.5 MED. Clinical assessment also indicated that a consecutive five-day application of soy essence protected skin from UV-induced redness. Diffuse reflectance spectroscopy further illustrated that reduction of redness occurred at the highest irradiation dose (two MED) in this clinical study. In a following up measurements at seven days after the irradiation, it was found that flakiness existed for some of the control sites (placebo- or untreated), however none was found in both preventive treatment and post treatment. The study clearly demonstrates the usefulness and potential of Total Soy essence for daily defense against sun irradiation.

### Fade Facial Lentiginos (Age Spots)

Manifestations of photodamage are multidimensional. They include facial lentiginos, mottled hyperpigmentations, skin tone deterioration (sallowiness), and skin texture deterioration with the appearance of fine lines, coarse and fine wrinkles, and skin roughness. Overall, photodamages have many visible characteristics. There are numerous Rx and OTC cosmetics which target photodamage. Certain prescription products such as hydroquinone are very efficient in targeting subjects of PD symptoms—hyperpigmented lesions, but result in known side effects. There is a strong need for products which are effective over a broader range of photodamage symptoms as well as being gentle to the photodamaging skin. The nondenatured soy preparation was proven to reduce the appearance of solar lentiginos. A 12-week randomized, blind, half-face benchmark-controlled clinical study was conducted on  $n = 52$  skin types I to III healthy subjects with solar lentiginos/mild to moderate photodamage (2–5 on a scale of 9) to evaluate the clinical efficacy of a moisturizer lotion containing 2% Total Soy in reducing the appearance of solar lentiginos (78). The Melanex (3% hydroquinone) was used as a benchmark in this clinical study. No soy related signs of irritation (rash, erythema, edema, stinging, burning, and itching) nor sensitization were reported in the study. Total Soy lotion had significant ( $p < 0.01$ ) improvement in facial lentiginos, overall photodamage, mottled hyperpigmentation, and skin sallowness from week 4 versus baseline. Soy lotion had no significant difference in overall photodamage ( $p > 0.71$ ) versus Melanex. At eight weeks, facial age/brown spot reduction was observed by 48% of the subjects for Soy lotion. In the same clinical study, soy lotion also had a significant improvement in coarse wrinkle from week 8 ( $p = 0.057$ ) and significant improvement in laxity ( $p = 0.057$ ) at week 12 versus baseline. Soy lotion is significant superior to Melanex in surface roughness reduction ( $p < 0.056$ ) and in facial sallowness reduction ( $p < 0.02$ ) at the end of the study (week 12). These results suggest that the Total Soy formulation may be considered as for reducing lentigenos or age spots.

### Total Soy and UVA/UVB Protection

A double-blind, placebo-controlled clinical study was performed to determine the benefits of using a daily Total Soy facial preparation with broad spectrum SPF 30 in improving various skin tone and textural parameters (79). Sixty-three patients, between the ages of 30 and 50 exhibiting moderate levels of skin roughness, blotchiness and mottled hyperpigmentation were enrolled into the 12-week study. Dermatologist evaluations, self-assessments and instrumental analysis were completed at various time points

during the 12-week study. Dermatologist evaluations demonstrated significant improvements ( $p < 0.05$ ) in skin roughness, clarity, and mottled hyperpigmentation after two-week use of the Total Soy facial preparation containing SPF 30. Significant improvements ( $p < 0.05$ ) in mottled hyperpigmentation, blotchiness, appearance of fine lines and overall skin tone and texture were observed versus the placebo control group after only two weeks of use. It showed improvements in mottled hyperpigmentation, blotchiness and fine lines when compared with the placebo control group and baseline mean values. After four weeks of use there was over a 35% mean improvement in skin blotchiness and clarity of the skin. The colorimeter showed a significant increase ( $p < 0.05$ ) in skin luminosity with a significant decrease ( $p < 0.05$ ) in the yellowness correlating to an improvement in skin brightness and overall skin tone. Self-assessments showed that subjects began to perceive significant improvements ( $p < 0.05$ ) in various skin tone, texture and brightness parameters as soon as one week of using the Total Soy and SPF 30 facial moisturizer. Additional studies showed that the Total Soy and SPF 30 moisturizer was noncomedogenic, gentle to the skin and did not induce dermal sensitization. The sunscreens used in this Total Soy moisturizer have been shown to be compatible with Total Soy and photostable on the basis of both clinical and scientific studies.

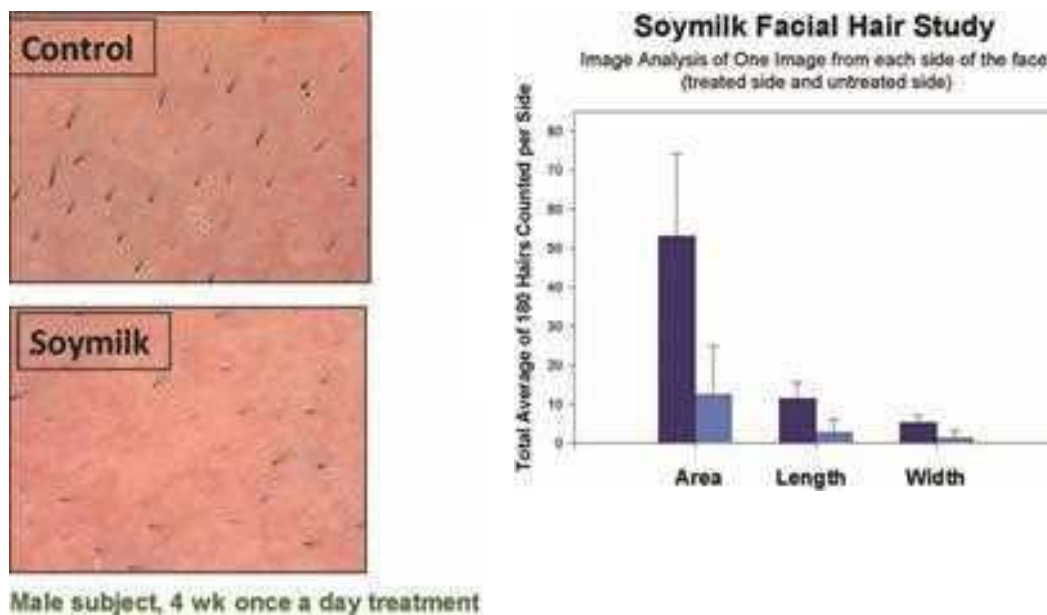
### Delay in Hair Regrowth

A double-blind, placebo-controlled study examining leg hair regrowth enrolled 20 women aged 29 to 55. All subjects shaved immediately before the baseline randomization visit and then just once a week prior to returning for the follow-up assessments. Evaluations consisted of patient and investigator ratings of hair growth and adverse events. In addition, the treatment effects were quantified in terms of hair counts and hair growth rates through digital analysis of video microscope images taken of two areas of each leg—one toward the knee and the other close to the ankle. All of the women completed the study, and the only adverse effect reported was mild dryness. The digital analyses showed that mean hair regrowth rate was unchanged on the placebo-treated leg but progressively decreased with application of the soy-based gel (Fig. 15.7). As a result, the mean regrowth rate was consistently reduced on the treated leg for both areas measured at each weekly visit. By study end, the between-group difference for the effects on the lower portion of the leg achieved statistical significance.

Hair counts, which included any stubble, were consistently lower on the soy-treated leg compared with placebo beginning by Week 2. However, there were large standard deviations in the means and the differences between treatments did not achieve statistical significance. The subjective evaluations from the study participants indicated the treatment caused the hair to regrow more slowly and that the hair present was softer. The proportion of women noting both of those outcomes increased over time. At Week 1, about 40% of women noted the hair on the soy-treated leg was softer and about 35% noticed the growth rate was reduced. At Week 4, about two-thirds of the participants indicated that the hair on the soy-treated leg was softer and showed a reduced growth rate. For the weekly assessments of the placebo-treated leg, between 5% and 22% of women considered the hair that regrew to feel softer, while 12% to 28% remarked that the hair growth rate was reduced. The results of self-assessments were consistent with investigator ratings that noted beneficial differences in hair appearance or quality favoring the soy-treated leg in



**Figure 15.7** (A) Displays that for a double-blind, placebo-controlled study examining leg hair regrowth comparing soy formula versus placebo mean hair regrowth rate was stable on the placebo-treated leg but (B) progressively decreased with application of the soy-based gel (active) after two weeks of the application of soy preparation.



**Figure 15.8** Three Caucasian male volunteers, Fitzpatrick skin type II, who shaved daily followed by applying a soy preparation daily for four weeks. The left images are the photos for the shaved areas. The right chart displays the averaged hair area, length and width at the end of the study.

two-thirds of the study participants noticed delaying hair regrowth, and smoothing and moisturizing the skin (80–82). The Total Soy lotion was also found to reduce the facial hair area, length and width for male subjects of Fitzpatrick skin type II, who shaved daily followed by applying a soy preparation daily for four weeks as illustrated in Figure 15.8.

### Improvement of Acnic Inflammatory Lesions

The soy preparation was also proven to reduce acne-related blotchiness and erythema. A pilot clinical study was conducted to evaluate the potential of a soy formulation to reduce erythema and acne lesions in acne sufferers and to look at the potential of this formulation to induce acne lesions in healthy

## SOY Reduces Pimples and Blotches



**Figure 15.9** Shows the visible images of a female subject (A) before and (B) after using Total Soy preparation. After 45 days of Total Soy product application, there was a statistically significant reduction in erythema and inflammatory papules ( $p < 0.001$ ).

subjects. In the mild acne group, there was a statistically significant reduction in erythema and inflammatory papules after treatment with the soy preparation ( $p < 0.001$ ). There was a statistical trend in the reduction of the number of noninflammatory comedones (Fig. 15.9) (77). Twenty-six subjects with mild acne and 29 subjects with no acne were entered into this open-label study after IRB approval and informed consents. All subjects were female and 64% were Caucasian and 36% were Black. Subjects applied the test product twice daily. Clinical safety evaluations were made on days 3, 7, 14, 21, 28, and 35. Dermatologist evaluations were made on day 0 (baseline) and day 45. In subjects with no acne, there was no statistically significant increase in comedones or papules and pustules. For those subjects with mild acne, a highly significant decrease from baseline in the number of inflammatory papules ( $p = 0.001$ ), a 41.9% decrease, was noted after 45 days of treatment with the soy preparation (77). This soy product was exceptionally well tolerated with no reports of stinging, burning or itching at any time point evaluated. These results suggest that this soy formulation may be considered as noncomedogenic and may be utilized as an important therapeutic option in acne sufferers.

### Enhancement in Skin Firming

Besides preclinical discussed in the previous section on enhancement in skin collagen production and elastin repair, clinical studies have further indicated that a soy composition containing a complete spectrum of soy components can improve the skin firming and elasticity. In a 12-week, double-blind, randomized clinical study of skin aging, using a full-face design with twice daily applications, the Total Soy composition provided significant improvement in skin laxity versus baseline as early as week four. Cutometer measurements further supported the dermatologist assessment in that 100% of the Total

Soy-treated subjects showed improvement in skin firmness and distensibility.

### Sebum Production and Moisturization Balance in Combination Skin

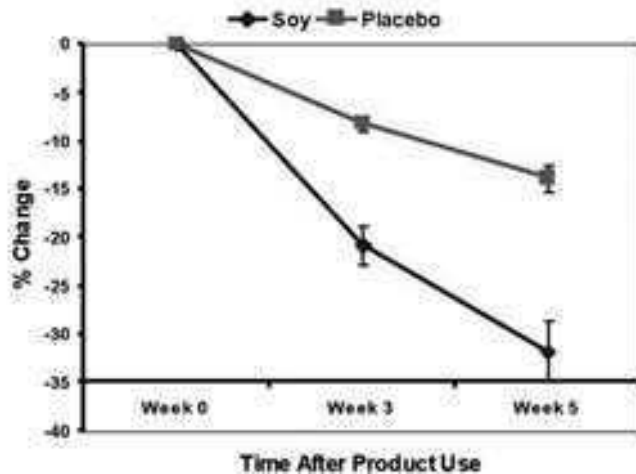
A five-week, half-face, double-blind, placebo-controlled clinical study was conducted on twenty-three female subjects aged 20 to 35 years with combination skin (Fitzpatrick types I and II). Combination skin was defined as facial skin having at least one oily area and one dry area on each of the half face. The oily and dry areas were determined by sebumeter reading at  $>200$  and  $<66$  ( $\text{g}/\text{cm}^2$ ), respectively. Subjects applied soy preparation or placebo on the designated side of the face daily for five weeks. Measurements were taken at baseline, weeks 1, 3, and 5 on the forehead, cheek, and chin. Scaling, moisturization, oiliness and smoothness were evaluated by instrumental measurements and digital photography. The results indicated this Total Soy preparation significantly reduced sebum in oily patches ( $p < 0.05$  for chin areas as displayed in Fig. 15.10) and enhanced moisturization for dry patches as compared with placebo ( $p < 0.05$ ). Subject self-assessments demonstrated enhanced skin smoothness and oil reduction, which correlated with the instrumental results. Approximately 70% of the subjects noted improvement on the soy-treated side, while only 17% on placebo-treated side noted improvement in overall tone and texture.

### Effects on Ethnic Skin

Skin color is the most noticeable difference among different ethnic skins. Postinflammatory hyperpigmentation (PIH) is of major concern to dark-skinned individuals. Nondenatured soy lotion combined with retinol and salicylic acid has clinically proven to reduce incidence and severity of PIH in as early as one week (83).



## Total Soy Had Oily Reduction Measured by Sebum Analysis



**Figure 15.10** Displays the results in which Total Soy preparation significantly reduced sebum in oily patches ( $p < 0.05$  for chin areas) versus placebo.

**Table 15.6** Summary of the Recent Results in Understanding the Soy's Bioactivity and Its Therapeutic Effects on the Human Skin

In vitro tests	Total Soy's bioactivity/therapeutic effects on human skin	References
Thiol retention activity antioxidant	Maintain the normal skin cell metabolism even when exposed to a harsh environment, e.g., smoke-induced loss of thiols	55,61
Soybean trypsin inhibition activity	Protease-activated receptor 2 in skin depigmentation (e.g., freckles, mottled hyperpigmentation, age spots) and delay hair regrowth	3–5,32,33,66–69
Collagen synthesis	Enhance skin firming	58
Elastin	Enhance skin elasticity	58
Anti-inflammation	Reduce skin scaliness, erythema and pain associated with sun exposure; reduce the number of inflammatory papules ( $p < 0.001$ vs. baseline) in mild acne subjects	66–68

A four-month, double-blind, placebo-controlled, randomized clinical study was conducted to evaluate the efficacy of a topical formulation of the present invention in improving the appearance of acne and post acne PIH in 41 male and female Asian, African-American, and Hispanic subjects with Fitzpatrick skin types III to V and mild acne vulgaris (10–50 total facial acne lesions), 12 to 45 years of age. Subjects had physically distinct, recent, facial PIH acne marks. Subjects were asked to apply the test preparation twice (a.m. and p.m.) on the face.

The Total Soy composition showed a significant decrease in darkness, roughness and erythema compared with baseline at week 4 and continued at weeks 8, 12, and 16 with reduction in darkness seen as early as week 1. Clinical expert grading of photos showed that the soy lotion showed an average percent improvements in PIH size of 41% at week 4, 68% at week 8, 82% at week 12 and 92% at week 16. This was statistically significantly more effective than the placebo composition at weeks 4, 8, 12, and 16. This composition was effective on 91% of subjects at week 4 and on 100% of subjects at weeks 8, 12, and 16.

Expert clinical grading showed an average percent improvements in PIH darkness of 41% at week 4, 63% at week 8, 80% at week 12 and 92% at week 16. This was statistically significantly more effective than the placebo composition at weeks 8 and 12. This composition was effective on 95% of subjects at week 4 and on 100% of subjects at weeks 8, 12, and

16. Further statistical analysis of the data also showed that the Total Soy composition worked faster than the placebo in reducing the size and darkness of PIH marks.

Additionally, Total Soy also addressed those important issues of using natural ingredients for skin care, including free from any trace pesticides/herbicides and any toxic heavy metals, for example, lead and arsenic, non-GMO and very low microbial contents adequate for cosmetic formulations. The skin care formulas prepared from Total Soy are stable throughout the shelf life, and to possess the key bioactivities as summarized in Table 15.6. These bioactivities were then proven in clinical studies to improve the skin conditions, including reduction in hyperpigmentation, sun damages, unwanted hair, overly oily and dry, and acne.

### SUMMARY REMARKS

Fundamentally understanding the mechanisms of action in soy allowed the discovery of its skin care benefits. Topical soy preparations containing stabilized Total Soy with a complete spectrum of soy components were proven to provide broad skin care benefits.

### ACKNOWLEDGMENT

The author would like to thank Dr Ying Sun for valuable scientific inputs.

## REFERENCES

- Chen KT, ed. General Explanation of Compendium of Materia Medica. Xue Yuan Publisher, 1992:1255-1258.
- Scambia G, Mango D, Signorile PG, et al. Clinical effects of a standardized soy extract in postmenopausal women: a pilot study. *Menopause* 2000; 7:105-111.
- Seiberg M, Paine C, Sharlow E, et al. The protease-activated receptor-2 regulates pigmentation via keratinocyte-melanocyte interactions. *Exp Cell Res* 2000; 254:25-32.
- Paine C, Sharlow E, Liebel F, et al. An alternative approach to depigmentation by Soybean extracts via inhibition of the PAR-2 pathway. *J Invest Dermatol* 2001; 116:587-595.
- Seiberg M, Liu J-C, Sharlow E, et al. Soy milk reduces hair growth and hair follicle dimensions. *Exp Dermatology* 2000; 10:405-413.
- Ho PT. The loss and the origin of Chinese agriculture. *Am Hist Rev* 1969; 75:1-36.
- Hymowitz T. On the domestication of the soybean. *Econ Bot* 1970; 24:408-421.
- Ensminger A, Konland JL, Robson J. Concise Encyclopedia of Foods and Nutrition. 2nd ed. Boca Raton: CRC Press, 1994:2017-2035.
- Polunin M. Healing Foods. 1st ed. New York: DK Publishing, 1997:70.
- Cassidy A, Bingham S, Setchell K. Biological effects of a diet of soy protein rich in isoflavones on the menstrual cycle of premenopausal women. *Am J Clin Nutr* 1994; 60:333-340.
- Barnes S. The chemopreventive properties of soy isoflavonoids in animal models of breast cancer. *Breast Cancer Res Treat* 1997; 46:169-179.
- Stoll BA. Eating to beat breast cancer: potential role for soy. *Ann Oncol* 1997; 8:223-225.
- Goodman M, Wilkens L, Hankin J, et al. Association of soy and fiber consumption with the risk of endometrial cancer. *Am J Epidemiol* 1997; 146:294-306.
- Morton MS, Matos-Ferreira A, Abranches-Monteiro L, et al. Measurement and metabolism of isoflavonoids and lignans in human male. *Cancer Lett* 1997; 114:145-151.
- Barnes S. Evolution of the health benefits of soy isoflavone. *Proc Soc Exp Biol Med* 1998; 217:386-392.
- Anonymous. The Soy Connection, United Soy Board. Chesterfield, MO. Vol. 6, #2, Spring, 1998.
- Messina M, Gardner C, Barnes S. Gaining insight into the health effects of soy but a long way still to go: commentary on the Fourth International Symposium on the role of soy in preventing and treating chronic disease. *J Nutr* 2002; 132:547S-551S.
- Barnes S, Messina M. Introduction and satellite session at the Fourth International Symposium on the role of soy in preventing and treating chronic disease. *J Nutr* 2002; 132:545S-546S.
- Food and Drug Administration, Food labeling, health claims, soy protein, and coronary heart disease. *Fed Regist* 1999; 57:699-733.
- Cosmetics & Toiletries, Cosmetic Bench Reference. New York: Allured Pub. Corp., 1998, ISBN 0931710510.
- Wu W, Hettiarachchy NS. Foaming and emulsifying properties of soy protein isolate and hydrolyzates in skin and hair products. *J Surfact Deterg* 1998; 1:241-246.
- Bradley TF. Nonedible soybean oil products. In: Markley KS, ed. Soybeans and Soybean Products. Volume 2. New York: Interscience Publishers, Inc., 1951:3-59.
- Lanigan RS. Cosmetic ingredient review expert panel, "Final report on the safety assessment of PEG-5, -10, -16, -25, -30, and -40 soy sterol." *Int J Toxicol* 2000; 19(suppl 1):29-46.
- Jimbow K, Jimbow M. Chemical, pharmacologic and physical agents causing hypomelanoses. In: Nordlund JJ, Boissy RE, Hearing VJ, et al., eds. *The Pigmentary System*. Oxford: Oxford University Press, 1998:621-627.
- Birk Y. The Bowman-Birk inhibitor. Trypsin- and chymotrypsin-inhibitor from soybeans. *Int J Pept Protein Res* 1985; 25:113-131.
- Kennedy AR. The Bowman-Birk inhibitor from soybeans as an anticarcinogenic agent. *Am J Clin Nutr* 1998; 68:1406S-1412S.
- Billings PC, Habres JM. A growth-regulated protease activity that is inhibited by the anticarcinogenic Bowman-Birk protease inhibitor. *Proc Natl Acad Sci* 1992; 89:3120-3124.
- Nystedt S, Emilsson K, Wahlestedt C, et al. Molecular cloning of a potential proteinase activated receptor. *Proc Natl Acad Sci U S A* 1994; 91:9208-9212.
- Nystedt S, Emilsson K, Larsson AK, et al. Molecular cloning and functional expression of the gene encoding the human proteinase-activated receptor 2. *Eur J Biochem* 1995; 232:84-89.
- Nystedt S, Larsson AK, Aberg H, et al. The mouse proteinase-activated receptor-2 cDNA and gene. Molecular cloning and functional expression. *J Biol Chem* 1995; 270:5950-5955.
- Déry O, Bunnett NW. Proteinase-activated receptors: a growing family of heptahelical receptors for thrombin, trypsin and tryptase. *Biochem Soc Trans* 1999; 27:246-254.
- Déry O, Corvera CU, Steinhoff M, et al. Proteinase-activated receptors: novel mechanisms of signaling by serine proteases. *Am J Physiol* 1998; 247:C1429-C1452.
- Marthinuss J, Andrade-Gordon P, Seiberg M. A secreted serine protease can induce apoptosis in Pam12 keratinocytes. *Cell Grow Differ* 1995; 6:807-816.
- Santulli RJ, Derian CK, Darrow AL, et al. Evidence for the presence of a protease-activated receptor distinct from thrombin receptor in human keratinocytes. *Proc Natl Acad Sci* 1995; 92:9151-9155.
- Sharlow ER, Paine C, Babiarz L, et al. The protease activated receptor-2 upregulates keratinocyte phagocytosis. *J Cell Sci* 2000; 113:3093-3101.
- Seiberg M, Paine C, Sharlow E, et al. Inhibition of melanosome transfer results in skin lightening. *J Invest Dermatol* 2000; 115:162-167.
- Olsen EA. Methods of hair removal. *J Am Acad Dermatol* 1999; 40:143-155; quiz 156-157.
- Panaretto BA. Gene expression of potential morphogenes during hair follicle and tooth formation: a review. *Reprod Fertil Dev* 1993; 5:345-360.
- Chase HB. Growth of the hair. *Physiol Rev* 1954; 34:113-126.
- USDA National Nutrient Database for Standard Reference, 1999. Available at: <http://www.nal.usda.gov/fnic/foodcomp/search/>.
- Liu KS, Markakis P, Smith D. Trypsin inhibition by free fatty acids and stearoyl-CoA. *J Agric Food Chem* 1990; 38:1475-1478.
- Liu K. Soybeans, Chemistry, Technology and Utilization. Gaithersburg: Aspen Publishers, 1999.
- Ando H, Ryu A, Hashimoto A, et al. Linoleic acid and alpha-linolenic acid lightens ultraviolet-induced hyperpigmentation of the skin. *Arch Dermatol Res* 1998; 290:375-381.
- Tanojo H, Junginger HE. Skin permeation enhancement by fatty acids. *J Dispersion Sci Technol* 1999; 20(1 and 2):127-138.
- Galvez AF, Chen N, Macasieb J, et al. Chemopreventive property of a soybean peptide (Lunasin) that binds to deacetylated Histones and Inhibit Acetylation. *Cancer Res* 2001; 61:7473-7478.
- Wei H, Bowen R, Cai Q, et al. Antioxidant and antiprotection effects of soybean isoflavone genistein. *Proc Soc Exp Biol Med* 1995; 208(1):124-130.
- Widyarini S, Spinks N, Reeve VE. Protective effect of isoflavones derivative against photocarcinogenesis in a mouse model. *Redox Rep* 2000; 5(2-3):156-158.
- Berkow R, Bears MH, et al (eds.). *Merck Index*. 13th ed. Whitehouse Station: Merck & Co., Inc., 2001.
- Brincat MP. Hormone replacement therapy and the skin. *Maturitas* 2000; 35:107-117.
- Wachter R, Salka B, Magnet A. Phytosterols. *Cosmet Toiletries Mag* 1995; 110:72-82.
- Corbella A. Applications of phytosterols as active principles. *Cosmetic News* 1997; 20(117):419-421.
- Pinnell SR. Cutaneous photodamage, oxidative stress, and topical antioxidant protection. *J Am Acad Dermatol* 2003; 48(1):1-19.
- Guy RH, Hostynek JJ, Hinz RS, et al. *Metals and the Skin: Topical Effects and Systemic Absorption*. Illustrated edition. New York: Marcel Dekker, 1999.

54. Gohtani S, Yamano Y. Soybean saponin and natural surfactants. *Hyomen* 1991; 29(7):559–570.
55. Yoshiki Y, Okubo K. Active oxygen-scavenging effects of soybean studied by luminescence method. *BRAIN Tech News* 1999; 75:8–11.
56. Kurtz E, Nebus J, Walczak V. The essence of safety testing on soy extract formulations, Poster 139. 59th Annual Meeting of American Academy of Dermatology, Washington, D.C., March 2–7, 2001.
57. Markiewicz L, Garey J, Adlercreutz H, et al. In vitro bioassays of non-steroidal phytestrogens. *J Steroids Biochem Mol Biol* 1993; 45:399–405.
58. Jefferson WN, Newbold RR. Potential endocrine-modulating effect of various phytoestrogen in the diet. *Nutrition* 2000; 16:658–662.
59. Farnsworth NR, Bingel AS, Cordell GA. Potential value of plants as sources of new antifertility agents. *J Pharm Sci* 1975; 64:717–752.
60. Merritt RJ, Jenks BH. Safety of soy-based infant formulas containing isoflavones: the clinical evidence, Supplement: Fifth Internat'l Symposium on the Role of Soy in Preventing and Treating Chronic Disease. *J Nutrition* 2004; 134:1220S–1224S.
61. Connor MJ, Wheeler LA. Depletion of cutaneous glutathione by ultraviolet radiation. *Photochem Photobiol* 1987; 46:239–246.
62. Liu JC. Applications of soy in skin care. *J Nutr* 2002; 132:574.
63. Liu J-C, Seiberg M, Liebel F, et al. Preclinical and clinical evaluation of total soy preparation in improving skin physical tone parameters, Poster 182. 60th Annual Meeting of American Academy of Dermatology, New Orleans, LA, February 22–27, 2002.
64. Bauer EA, Uitto J. Special tissue collagen: skin. In: Weiss JB, Jayson MTV, eds. *Collagen in Health and Disease*. Churchill Livingstone: Edinburgh, 1982:474–487.
65. Kligman LH. Effects of all-trans-retinoic acid on the dermis of hairless mice. *J Am Acad Dermatol* 1986; 15(4 pt 2):779–785, 884–887.
66. Zhao RB, Bruning E, Rossetti D, et al. Extracts from Glycine max (soybean) induce elastin synthesis and inhibit elastase activity. *Exp Dermatol* 2009; 18(10):883–886.
67. Young JM, De Young LM. Cutaneous models of inflammation for the evaluation of topical and systemic pharmaceutical agents. In: Chang JY, Lewis A, eds. *Pharmacological Methods in the Control of Inflammation*. New York: Alan R. Liss, 1989:215–231.
68. Saliou C, Seiberg M, Liu J-C, et al. Use of legume products for the treatment of external aggressions. U.S. Pat Appl Publ 2002, cont-in-part of Ser. No. US 2001-795762.
69. Davis W Jr., Ronai Z, Tew KD. Cellular thiols and reactive oxygen species in drug-induced apoptosis. *J Pharmacol Exp Ther* 2001; 296(1):1–6.
70. Hayes JD, McLellan LI. Glutathione and glutathione-dependent enzymes represent a co-ordinately regulated defense against oxidative stress. *Free Radic Res* 1999; 31(4):273–300.
71. Connor MJ, Wheeler LA. *Photochem Photobiol* 1987; 46:239–246.
72. Tyrrell RM, Pidoux M: Correlation between endogenous glutathione content and sensitivity of cultured human skin cells to radiation at denned wavelengths in the solar ultraviolet range. *Photochem Photobiol* 1988; 47:405–412.
73. Huang TM, Xie JG, Lin CB, et al. Inhibitory effect of topical applications of non-denatured soymilk on the formation and growth of UVB-induced skin tumors. *Oncol Res* 2004; 14(7–8):387–397.
74. Chen NN, Scarpa R, Zhang L, et al. Nondenatured soy extracts reduce UVB-induced skin damage via multiple mechanisms. *Photochem Photobiol* 2008; 84:1551–1559.
75. Hermanns JF, Petit L, Martalo O, et al. Unraveling the patterns of subclinical pheomelanin-enriched facial hyperpigmentation: effect of depigmenting agents. *Dermatology* 2000; 201:118–122.
76. Wu J, Stamatias G, Kollias N, et al. Soy application for daily defense against sun irradiation. In: Ring J, Weidinger S, Darsow U, eds. *Skin and Environment—Perception and Protection*. 10th EADV Congress, Munich. Mondond: Bologna, Italy, 2001: 869–873.
77. Liu J-C, Seiberg M, Miller J, et al. Applications of soy in skin care. In: Ring J, Weidinger S, Darsow U, eds. *Skin and Environment—Perception and Protection*. 10th EADV Congress, Munich. Mondond: Bologna, Italy, 2001:881–884.
78. Wu J, Kollis K, Liu JC. Total Soy to diminish wrinkles and hyperpigmentation in photoaged population. 59th Annual Meeting of the American Academy of Dermatology. Washington, D.C., February 2005, Poster 101.
79. Nebus J, Costes F, Wallo W, et al. Clinical improvements in skin tone and texture using a facial moisturizer with a combination of Total Soy and SPF 30 UVA/UVB protection. *AAD* 2006.
80. Guttman C, Liu J-C, Seiberg M. *Dermatology Times* 2001; 22:24.
81. Au Ghyczy M, Nissen HP. Montecatini terme Italy. *J Appl Cosmetol* 1995; 13:109.
82. Archana S, Victoria D, Glenn N. Compositions and methods for treating skin conditions. U.S. patent application, 20050036963.
83. Sah A, Dole V, Nystrand G. Compositions and methods for treating skin conditions. U.S. patent publications, 2005, No. US 20050036963 A1.

# Kinetin

Stanley B. Levy

## INTRODUCTION

The success of retinoids and hydroxy acids as active ingredients in skin care products designed to improve the appearance of aging skin has stimulated the search for additional compounds. The use of both retinoids and hydroxy acids may be associated with skin irritation further encouraging interest in alternatives. A possible addition to this armamentarium is kinetin (N6-furfuryladenine). Kinetin is a plant hormone known for growth-promoting and antiaging effects in plants. Pyratine-6 (furfurylamino-tetrahydropyran-yladenine) has been more recently introduced as an antiaging ingredient. The incorporation of these materials into cosmeceuticals has prompted a more detailed review.

## CHEMISTRY

Kinetin was first isolated from autoclaved herring sperm DNA in 1955 (1,2). It is a derivative of one of the nucleic acid purine bases, adenine. Kinetin has been reported to be present in various plants (3,4) and human cell extracts (5). It has been identified as a naturally occurring base modification of DNA (6). The chemical structure of kinetin suggests that it can be formed from adenine and furfuryl (Fig. 16.1). The latter is a primary oxidation product of the deoxyribose moiety of DNA (7). It is not known if DNA repair enzymes remove this modified base from the DNA and make it available as free kinetin. Pyratine-6 is structurally similar to kinetin except for the addition of a tetrahydropyran-yl group.

## BIOLOGY

Kinetin was the first cytokinin identified (1,2). Cytokinins are plant growth substances that promote cell division and may play roles in cell differentiation. Most of the data for the biological properties of kinetin come from plant studies. Kinetin has been shown in plant systems to stimulate tRNA synthesis (8) and cell cycle progression (9). Calcium influx through the plasma membrane calcium channel in plant cells is stimulated by low levels of kinetin (10). More directly linked or related to antiaging, kinetin is known to prevent yellowing and senescence of leaves and slow down over ripening and degeneration of fruits (11).

Rattan and Clark (12) have reported the antiaging effect of kinetin on human skin cells and fruit flies. As little as 10 to 20 ppm of kinetin delay the onset of some biochemical and cellular changes associated with cellular aging in cell culture. Human skin fibroblast cell cultures of both young cells that had completed less than 20% of their potential *in vitro* life span and older cells that had completed 90% or more of their life span were studied. Results were compared with cell cultures

receiving no treatment (Table 16.1). Cytological manifestations of *in vitro* aging including cell enlargement, presence of multinucleated giant cells, accumulation of cellular debris and lipofuscin, and changes in actin filaments and microtubules were attenuated by the addition of kinetin. The number of cells per unit area in a confluent layer also markedly diminishes as a function of age. Kinetin treatment significantly diminished the age-associated reduction in cell yield (Fig. 16.2). Kinetin did not affect the longevity of culture cells or their ability to multiply.

A diet containing 20 to 50 ppm kinetin fed to fruit flies slowed down aging and development and prolonged average and maximum life span by 65% and 35%, respectively (13). The increase in life span was accompanied by a 55% to 60% increase in the antioxidant enzyme catalase (14). Catalase breaks down hydrogen peroxide associated with cell toxicity.

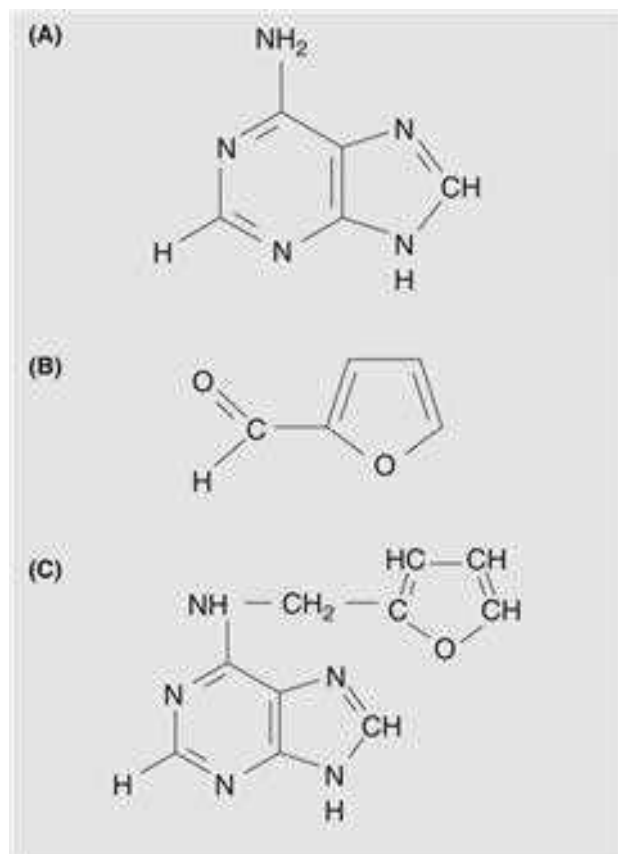
Kinetin has been demonstrated to have inhibitory activity on free radical formation of active platelets *in vitro* and thrombus formation *in vivo* (15). Kinetin may therefore be a potential therapeutic agent for arterial thrombosis. A cytokinin nucleoside, N6-furfuryladenine, has been shown to have antiproliferative and apoptogenic activity against various human cancer cell lines, suggesting potential anticancer activity (16). This activity has not been shown with kinetin.

## MECHANISM OF ACTION

The exact mechanism by which kinetin acts to exert its effects is unknown. Kinetin may act directly as a signaling molecule, involved in signal transduction, stimulating defense pathways such as DNA repair (17). Kinetin modulates and promotes calcium-induced differentiation of normal human keratinocytes that becomes progressively delayed during aging (18,19).

Kinetin may also act indirectly as a natural antioxidant (20), preventing the formation of reactive oxygen species or as a direct free radical scavenger (21). Oxygen radicals could abstract hydrogen from the  $\alpha$ -carbon of the amine bond N6-furfuryladenine (22). Oxygen radicals undergo a faster dismutation reaction when kinetin is complexed with copper. A direct effect of kinetin on superoxide dismutase activity has been observed in plants (20). Kinetin has also been shown to protect against oxidative and glycoxidative protein damage generated *in vitro* by sugars and an iron/ascorbate system (21).

The biological significance of kinetin's interaction with DNA or its antioxidant properties is unknown. However, pluripotency may be a necessary prerequisite for effective antiaging activity (23). A multistep protocol utilizing *in vitro* and *in vivo* studies designed to compare the oxidative stress capacity or various antioxidants demonstrated that kinetin performed favorably relative to other known antioxidants including tocopherol, ascorbic acid, and lipoic acid (24).



**Figure 16.1** The structures of adenine (A), furfuryl (B), and N6-furfuryladenine, or kinetin (C).

## CLINICAL STUDIES

Percutaneous absorption studies of kinetin with human cadaver skin demonstrate significant skin penetration (McCullough, unpublished study). A dose-response was shown with 0.01% versus 0.05% kinetin with tissue levels for both serum and lotion formulations. There was no significant difference in transdermal absorption with the two test formulations. Topical treatment with low-concentration kinetin normalized hyperpigmentation and improved age-related skin structure changes in hairless dogs (25).

Thirty subjects with mild to moderate photodamaged facial skin were treated with topical kinetin 0.1% twice daily for 24 weeks (26). Significant improvements were seen in tactile roughness, mottled hyperpigmentation, and fine wrinkles at

both 12 and 24 weeks. Overall photodamage was reported improved by both self-assessment and dermatologist grading. Transepidermal water loss decreased after 24 weeks consistent with skin barrier function improvement. Other than some initial contact folliculitis, no significant skin irritation was seen.

Ninety-eight subjects with mild to moderate photodamaged facial skin each applied a kinetin-containing lotion and creams for 10 weeks (Revlon Research Center, unpublished studies). All subjects were assessed at baseline 4, 8, and 10 weeks for photodamage parameters. Statistically significant improvements were noted in all parameters, greatest with texture, skin clarity, discrete and mottled pigmentation, fine wrinkling, and global appearance. No significant irritation was noted.

Forty female subjects, ages 22 to 57, having mild to moderate facial skin photodamage, underwent a 12-week split face, double-blind, controlled and randomized study comparing a topically applied kinetin-containing lotion twice daily on one side and retinol containing lotion on the other (Almay Research—poster exhibit American Academy of Dermatology meeting, New Orleans, Louisiana, February 2002). Evaluations at four-week intervals demonstrated significant improvements for all attributes graded including discrete and mottled pigmentation, fine wrinkling, and overall photodamage. The kinetin lotion produced greater improvements in texture and clarity.

Another nonplacebo-controlled trial demonstrated a beneficial effect of topical kinetin 0.1% lotion in reducing erythema and overall clinical scores in 17 subjects with mild to moderate rosacea (27). A study of topical kinetin 0.03% with niacinamide 4% in 52 Asian subjects over a 12-week period suggested some synergistic cosmetic benefits to the combination (28).

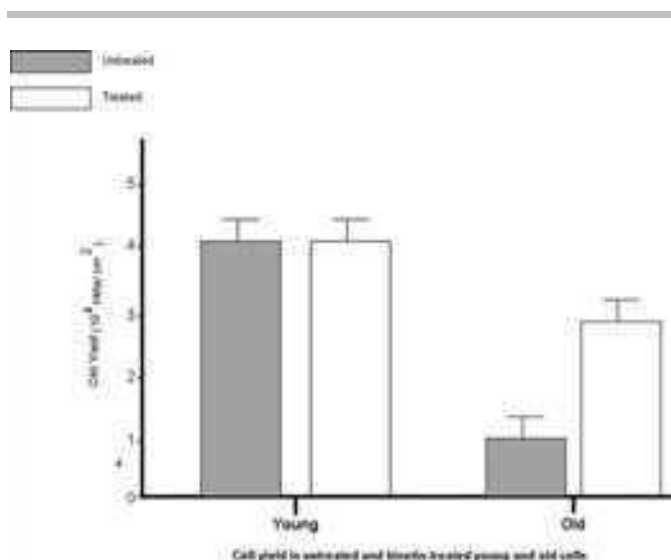
Nine kinetin-containing products in 200 subjects each were subject to modified Draize repeat insult patch tests. No instances of sensitization were seen in the challenge phase. In addition, controlled use testing for up to six weeks demonstrated no significant irritation (Almay research, unpublished studies). Six kinetin-containing products were tested in 10 subjects each with skin phototypes I–III for UV sensitivity with a solar simulator (Ivy Research Laboratory Inc., Philadelphia, Pennsylvania, unpublished study). Panelists were treated with once daily applications of 2 mg/cm<sup>2</sup> to the mid-back for two weeks at six sites. After the final applications, no difference in minimal erythema dose was noted between untreated control and treated sites. The above studies and clinical experience to date would suggest that kinetin has minimal or no potential to cause irritation, allergy, or photosensitization.

Pyratine-6, a kinetin analogue, was utilized as a topical agent in a single 12-week open label photoaging study. Improvement in skin roughness, moisturization, hyperpigmentation, and fine wrinkling was noted (29).

**Table 16.1** Kinetin's Effects on the Cytological Manifestations of In Vitro Aging

Characteristic	Untreated		Kinetin	
	Young	Old	Young	Old
Cell enlargement	None	Significant	None	Insignificant
Multinucleate cells	None	Present	None	None
Cellular debris	Minimal	Significant	Minimal	Minimal
Lipofuscin	Low	High	Low	Low
Actin filaments	Low	Highly polymerized	Diffuse	Less polymerized
Microtubules	Orderly	Disorganized	Orderly	Orderly

Source: From Ref. 12.



**Figure 16.2** Cell yield in untreated and kinetin-treated young and old cells. *Source:* From Ref. 12.

## CONCLUSION

Kinetin (N6-furfuryladenine), a plant growth regulator, has been demonstrated to delay a range of cellular changes associated with the aging of human skin cells in vitro. In addition, kinetin has antioxidant properties, formed as a response to free radical damage in human DNA. Before and after, clinical studies have demonstrated improvements in photodamaged skin. As is generally the case with new cosmeceutical ingredients, active to vehicle comparison studies are not available (30). Studies have clearly shown that the use of kinetin is not associated with significant irritation and a potential alternative for individuals sensitive to retinoids and hydroxy acids. Analogues of kinetin may also prove useful in the future.

## REFERENCES

1. Miller CO, Skoog F, Von Saltza MH, et al. Kinetin, a cell division factor from deoxyribonucleic acid. *J Am Chem Soc* 1955; 77:1392.
2. Miller CO, Skoog F, Okumura FS, et al. Isolation, structure, and synthesis of kinetin, a substance promoting cell division. *J Am Chem Soc* 1956; 78:1375–1380.
3. Ramman N, Elumalai S. Presence of cytokinin in the root nodules of *Casuarina equisetifolia*. *Ind J Exp Biol* 1996; 34:577–579.
4. Ratti N, Janardhanan KK. Effect on growth of and cytokinin contents of *pamrosa* (*Cymbopogon martinii* var. *motia*) by *Glo-mus* inoculation. *Ind J Exp Biol* 1996; 34:1126–1128.
5. Barciszewski J, Siboska GE, Pedersen BO, et al. Evidence for the presence of kinetin in DNA and cell extracts. *FEBS Lett* 1996; 393:197–200.
6. Barciszewski J, Siboska GE, Pedersen BO, et al. A mechanism for the in vivo formation of N6-furfuryladenine, kinetin as a secondary oxidative damage product in DNA. *FEBS Lett* 1997; 414:457–460.
7. Kahn QA, Hadi SM. Effect of furfural on plasmid DNA. *Biochem Mol Biol Int* 1993; 29:1153–1160.
8. Guadino RJ. Cytokinin induction of RNA polymerase I transcription in *Arabidopsis thaliana*. *J Biol Chem* 1997; 272:6799–6804.
9. Zhang K, Letham DS, John PC. Cytokinin controls the cell cycle of at mitosis by stimulating the tyrosine dephosphorylation and activation of p34cdc-2-like H1 histone kinase. *Planta* 1996; 200:2–12.
10. Shumaker KS, Gizinski MJ. Cytokinin stimulates dihydropyridine-sensitive calcium uptake in moss protoplasts. *Proc Natl Acad Sci USA* 1993; 90:10937–10941.
11. McFarland GA, Holliday R. Retardation of the senescence of cultured human diploid fibroblasts. *Exp Cell Res* 1994; 212:167–175.
12. Rattan SIS, Clark BFC. Kinetin delays the onset of ageing characteristics in human fibroblasts. *Biochem Biophys Res Commun* 1994; 201:665–672.
13. Sharma SP, Kaur J, Rattan SIS. Plant growth hormone kinetin delays ageing, prolongs the lifespan and slows down development of the fruitfly *Zaprionus parvitur*. *Biochem Biophys Res Commun* 1995; 216:1067–1071.
14. Sharma SP, Kaur J, Rattan SIS. Increased longevity of kinetin-fed *Zaprionus* fruitflies is accompanied by their reduced fecundity and enhanced catalase activity. *Biochem Mol Biol Int* 1997; 41:869–875.
15. Hsiao G, Shen MY, Lin KH, et al. Inhibitory activity of kinetin on free radical formation of active platelets in vitro and on thrombus formation in vivo. *Eur J Pharmacol* 2003; 465(3):281–287.
16. Cabello CM, Bair WB, Ley S, et al. The experimental chemotherapeutic N6-furfuryladenine (kinetin-riboside) induces rapid ATP depletion, genotoxic stress, and CDKN1A (p21) upregulation in human cancer cell lines. *Biochem Pharmacol* 2009; 77:1125–1138.
17. Barciszewski J, Rattan SIS, Siboska G, et al. Kinetin-45 years on. *Plant Sci* 1999; 148:37–45.
18. Berge U, Kristensen P, Ratan SIS. Kinetin-induced premature aging and altered differentiation of normal human epidermal keratinocytes undergoing aging in vitro. *Ann N Y Acad Sci* 2006; 1067:332–336.
19. Berge U, Kristensen P, Ratan SIS. Hormetic modulation of differentiation of normal human epidermal keratinocytes undergoing replicative senescence in vitro. *Exp Gerontol* 2008; 43:658–662.
20. Olsen A, Siboska GE, Clark BFC, et al. N6-furfuryladenine, kinetin protects against Fenton reaction-mediated oxidative damage to DNA. *Biochem Biophys Res Commun* 1999; 265:499–502.
21. Verbeke P, Siboska GE, Clark BFC, et al. Kinetin inhibits protein oxidation and glyoxidation in vitro. *Biochem Biophys Res Commun* 2000; 276:1265–1270.
22. Rattan SIS. N6-furfuryladenine (kinetin) as a potential anti-aging molecule. *J Anti-Aging Med* 2002; 5:113–116.
23. Hipkiss AR. On the “struggle between chemistry and biology during aging”—implications for DNA repair, apoptosis and proteolysis, and a novel route of intervention. *Biogerontology* 2001; 2(3):173–178.
24. McDaniel DH, Neudecker BA, DiNardo JC. Idebenone: a new antioxidant—part I. Relative assessment of oxidative stress protection capacity compared to commonly known antioxidants. *J Cosmet Dermatol* 2005; 4:10–17.
25. Kimura T, Kunio D. Depigmentation and rejuvenation effects of kinetin on the aged skin of hairless descendants of Mexican hairless dogs. *Rejuvenation Res* 2004; 7:32–39.
26. McCullough JL, Weinstein GD. Clinical study of safety and efficacy of using topical kinetin 0.1% (Kinerase) to treat photodamaged skin. *Cosmet Dermatol* 2002; 15:29–32.
27. Wu JJ, Weinstein GD, Kricorian GJ, et al. Topical kinetin 0.1% lotion for improving the signs and symptoms of rosacea. *Clin Exp Dermatol* 2007; 32:693–695.
28. Chiu PC, Chan CC, Lin HM, et al. The clinical antiaging-aging effects of topical kinetin and niacinamide in Asians: a randomized, double-blind, placebo-controlled, split-face comparative trial. *J Cosmet Dermatol* 2007; 6:243–249.
29. McCullough JL, Garcia RL, Reece B. A clinical study of topical pyratine 6 for improving the appearance of photodamaged skin. *J Drugs Dermatol* 2008; 7:131–135.
30. Kligman C. Cosmeceuticals. *Dermatol Clin* 2000; 18:609–615.

## Urokinase and dry skin

Yuji Katsuta

### INTRODUCTION

Urokinase or urokinase-type plasminogen activator belongs to the trypsin-like serine protease family and activates inactive plasminogen to active plasmin. Because plasmin degrades fibrin clots, urokinase and plasmin are called fibrinolytic enzymes. These fibrinolytic enzymes function not only in blood but also in other organs, including the epidermis. They function in wound repair and also in many disease states such as psoriasis and pemphigus. Recently, urokinase and plasmin were found to function in dry skin as secondary exacerbating factors. Inhibitors of these enzymes were found to be effective in preventing dry skin.

This chapter reviews the functions of fibrinolytic enzymes, including urokinase, in dry skin. A new approach to skin care cosmetics for the prevention of dry skin is also described.

### DRY SKIN

Dry skin is visually characterized by dryness, scaling, and a rough texture (1,2). This condition is not a disease specific to certain people, but can be experienced by any healthy person, especially in a dry, cold season. Its effects are not limited to the impairment of beauty, but can include itching and even pain in severe cases. Moreover, chronic dryness is thought to accelerate skin aging. For these reasons, the prevention of dry skin is one of the most important functions of skin care cosmetics.

There are many external and internal primary factors that change the skin surface morphology and cause dry skin. The external factors include exposure to extremes of climate (cold, wind, dryness), chemicals (detergents, solvents), and ultraviolet radiation. The internal factors include various abnormalities in physiologic functions, illness, and mental stress. The change in dry skin is not restricted to appearance. The barrier function of the stratum corneum decreases and water is lost more easily. Furthermore, proliferation of keratinocytes is accelerated, and turnover of the epidermis is increased. The epidermis becomes hypertrophic. The differentiation of keratinocytes is also abnormal in dry skin, leading to the incomplete formation of the stratum corneum.

For these reasons, to prevent and improve dry skin, it is not sufficient to supply moisture to the stratum corneum. Applying creams topically for the purpose of occluding the skin surface is effective in improving the damaged barrier function, but this is not a fundamental treatment. To maintain the skin in a healthy state, it is essential to protect the epidermis from the inside. Maintaining the normal proliferation of keratinocytes and keeping epidermal differentiation normal are important requirements for preventing dry skin.

### APPROACH TO FINDING INTRAEPIDERMAL SECONDARY FACTORS THAT CAUSE DRY SKIN

To elucidate the mechanism of dry skin occurrence and develop effective compounds for preventing the appearance of dry skin, attempts have been made to identify intraepidermal secondary factors that cause and accelerate dry skin formation (1,3,4). These putative secondary factors are thought to respond to primary factors, such as a dry environment, and cause further changes in dry skin. We have identified plasmin as one of the secondary factors by means of the following approach.

We created an experimental dry skin model by applying detergent to skin (1,3). Detergent is a well-known cause of dry skin and has often been used for artificially inducing dry skin. After applying 5% sodium lauryl sulfonate (SLS) once a day for four days continuously, we visually observed the condition of the skin on the fifth day. The features of dry skin, such as dryness, scaling, and a rough texture, were observed. At the same time, some physiologic values related to dry skin were measured. The water content of the stratum corneum of the SLS-treated area was reduced. The transepidermal water loss (TEWL) value of the area was increased, thus the barrier function of the stratum corneum was decreased. These physiologic features of the model resemble those of naturally occurring dry skin.

The barrier recovery test was also used, because the decrease of barrier function is one of the most important phenomena associated with dry skin (4). First, the barrier function of the stratum corneum was destroyed with a detergent or a solvent, then the time course of TEWL was measured. Activity of compounds to restore the barrier could be assessed by means of this test.

We assayed many kinds of compounds in the experimental dry skin model and the barrier recovery test (Table 17.1). Nonsteroidal anti-inflammatory agents such as acetylsalicylic acid, indomethacin, mefenamic acid, ibuprofen, and sodium diclofenac were tested first, but these compounds did not exhibit a suppressive effect on experimental induction of dry skin. The calcium channel inhibitors nifedipine and verapamil hydrochloride, and the calmodulin inhibitors *N*-(6-amino-hexyl)-5-chloro-1-naphthalenesulfonamide (W-7) and trifluoperazine were also ineffective. Then protease inhibitors were tested, and we found that *trans*-4-(aminomethyl)cyclohexane carboxylic acid (*t*-AMCHA) prevented epidermal hypertrophy and suppressed the appearance of dry skin. This compound is an inhibitor of plasmin, which belongs to the trypsin-type serine protease family. Tosyl-lysine chloromethyl ketone (TLCK, *L*-1-chloro-3-(4-tosylamido)-7-amino-2-heptane hydrochloride), a nonspecific inhibitor of trypsin-type proteases, was also effective. In contrast, other protease inhibitors such as ethylenediaminetetraacetic acid (EDTA) (a metalloprotease inhibitor), pepstatin (an aspartate protease inhibitor),

**Table 17.1** List of the Compounds Screened for Effectiveness in Preventing Dry Skin Formation

Name of compound	Effectiveness
<b>Nonsteroidal anti-inflammatory agents</b>	
Acetylsalicylic acid	—
Indomethacin	—
Mefenamic acid	—
Ibuprofen	—
Sodium diclofenac	—
<b>Calcium channel inhibitors</b>	
Nifedipine	—
Verapamil hydrochloride	—
<b>Calmodulin inhibitors</b>	
<i>N</i> -(6-aminohexyl)-5-chloro-1-naphthalenesulfonamide (w-7)	—
Trifluoperazine	—
<b>Protease inhibitors</b>	
Trypsin-like serine protease inhibitor	—
Tosyl-lysine chloromethyl ketone (TLCK)	+
<b>Plasmin inhibitor</b>	
<i>trans</i> -4-(Aminomethyl)cyclohexane Carboxylic acid	+
<b>Chymotrypsin-like serine protease inhibitor</b>	
Chymostatin	—
<b>Aspartate protease inhibitor</b>	
Pepstatin	—
<b>Cysteine protease inhibitor</b>	
<i>L-trans</i> -Epoxy succinyl-leucylamide-(4-guanidino)butane (E64)	—
<b>Metalloprotease inhibitor</b>	
Ethylenediaminetetraacetic acid (EDTA)	—

*L-trans*-epoxy succinyl-leucylamide-(4-guanidino)butane (E64) (a cysteine protease inhibitor), and chymostatin (a chymotrypsin-like serine protease inhibitor) had no beneficial effect.

Effectiveness of *t*-AMCHA was shown not only in experimentally induced dry skin but also in naturally occurring dry skin. A double-masked clinical test was carried out in the dry, cold winter season in Japan. One side of the face of the trial subjects was treated with cream containing *t*-AMCHA for one month and the other side was treated with a placebo cream. The skin texture of the *t*-AMCHA-treated side was significantly improved. Some existing skin care products contain *t*-AMCHA as an effective ingredient.

**POSSIBLE INVOLVEMENT OF PLASMIN IN SKIN DISEASES**

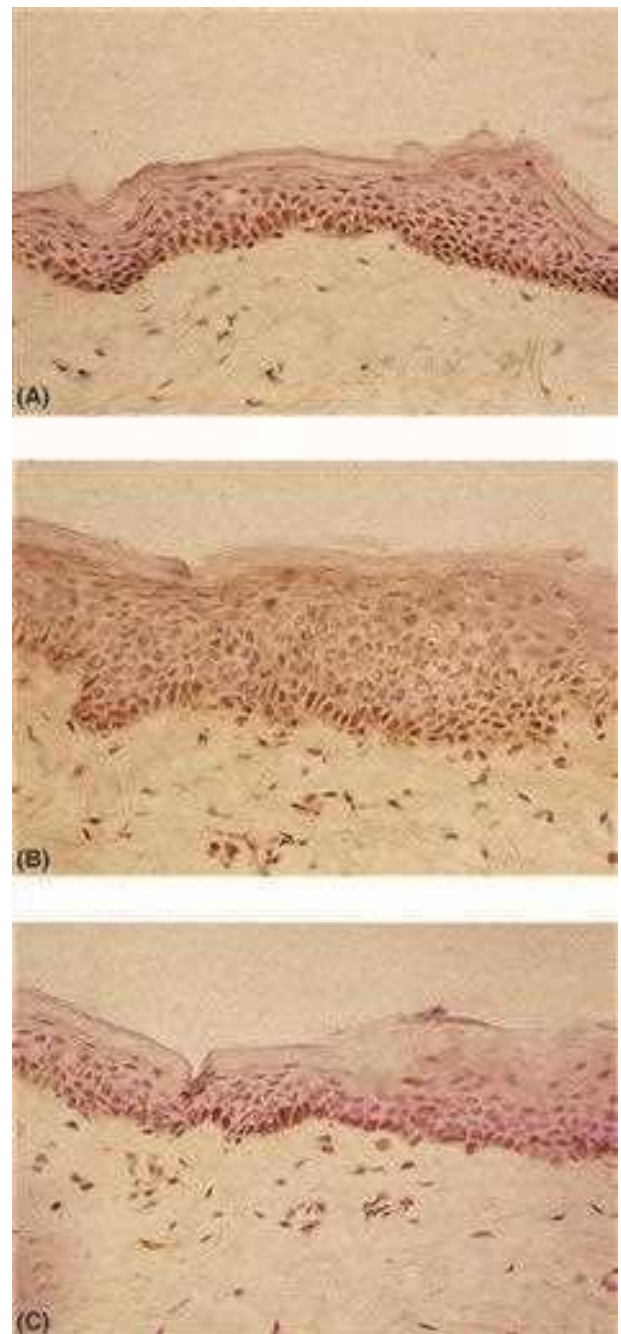
As described earlier, plasmin was found to be a secondary factor that causes and accelerates dry skin formation. This enzyme is a trypsin-like serine protease that is distributed mainly in plasma. Although its main function is lysis of fibrin in coagulated blood clots, plasmin also exists in adrenal, kidney, brain, testis, heart, lung, uterus, spleen, thymus, and gut (5).

Plasmin exists in the epidermis as well. It is known to be expressed in diseases such as psoriasis (6). The epidermis of psoriatic skin is extremely hypertrophic, and the proliferation of keratinocytes is rapid. The expression of plasmin is confined to the basal cell layer of the normal epidermis, whereas in lesional psoriatic skin it is scattered throughout the epidermis. The increased plasmin activity may contribute to the disease manifestations.

Wounding the epidermis also increases plasmin (7). At the wound edge, keratinocytes proliferate and migrate rapidly

to cover the wounded area. Plasmin degrades the extracellular matrix at the wound edge to aid proliferation and migration of keratinocytes.

Plasmin may contribute to dry skin formation as well, because plasmin inhibitors were effective in ameliorating dry skin (1,3). To confirm this, we tried to detect plasmin in dry skin. We induced dry skin on the inner forearm of healthy male volunteers by repeated SLS application and then biopsied the treated area. Immunohistologic staining with antiplasmin monoclonal antibody was performed. As shown in Figure 17.1,



**Figure 17.1** Localization of plasmin in intact skin (A), in experimentally induced dry skin (B), and in experimentally induced dry skin treated with *t*-AMCHA (C). Source: From Ref. 3.



plasmin was localized throughout the epidermis of experimentally induced dry skin, but it was restricted to the basal layer in intact skin. Treatment with *t*-AMCHA was extremely effective in preventing changes in the intraepidermal distribution of plasmin associated with dry skin as well as in suppressing epidermal hypertrophy.

Epidermal hypertrophy is common in psoriasis, wounding, and dry skin. Plasmin may be involved in promoting the proliferation and migration of keratinocytes in these skin states, resulting in epidermal hypertrophy; that is, it may stimulate keratinocyte proliferation in response to primary factors such as detergents.

### PLASMINOGEN ACTIVATOR (UROKINASE) IN DRY SKIN

Plasmin is biosynthesized as an inactive precursor called plasminogen. The cleavage of Arg560-Val561 of plasminogen activates this precursor molecule. Two major proteases are involved in plasminogen activation. One of them is urokinase-type plasminogen activator (u-PA) and the other is tissue-type plasminogen activator (t-PA). These plasminogen activators, like plasmin, belong to the trypsin-like serine protease family.

Aberrant plasmin activity in the epidermis may require increased levels of plasminogen activators. Indeed, the lesional epidermis from patients with psoriasis contains elevated levels of plasminogen activators compared with nonlesional epidermis or epidermis from normal individuals (8,9). Plasminogen activators are also increased at the wound edge (10,11). In psoriasis, t-PA is thought to be the major plasminogen activator, whereas urokinase may be predominant in wounding. Plasminogen activators may also have a role in dry skin formation.

Plasminogen activator activity was detected in dry skin. Stratum corneum obtained from dry skin by tape stripping had the activity of lysing fibrin *in vitro*. Because this lysis was completely inhibited when antibody against urokinase was added, the major plasminogen activator in dry skin might be urokinase. *In situ* zymography was carried out to confirm the presence of plasminogen activator activity *in vivo*. In the SLS-treated skin, plasminogen was activated in the epidermis, whereas little activity was seen in the control skin (4).

Plasmin is thus an important secondary factor that induces and accelerates dry skin formation. Urokinase in the epidermis may be another secondary factor that activates plasminogen.

### UROKINASE ACTIVATION IN THE STRATUM CORNEUM OF DRY SKIN

Urokinase belongs to the trypsin-like serine protease family, like its substrate plasmin. It is also produced and secreted by cells as an inactive single-chain precursor called pro-uPA (Fig. 17.2). Cleavage of Lys158-Ile159 of pro-uPA is essential for its activation.

Recently, it was found that urokinase was activated in the stratum corneum after barrier disruption (12). As a result of *in situ* zymography, plasminogen activator activity was detected in the stratum corneum only one hour after barrier destruction (Fig. 17.3). This indicated that urokinase is activated in the stratum corneum at an early stage of dry skin formation. The stratum corneum forms the surface layer of our bodies and is always exposed to the environment. This activation of

urokinase in the stratum corneum might be the trigger process in forming dry skin.

Urokinase activation in the stratum corneum was also tested by means of an *in vitro* assay. Human stratum corneum was collected by peeling and homogenized in a glass homogenizer. The homogenate was washed with glycine buffer to remove endogenous urokinase. We incubated pro-uPA with the insoluble components of the stratum corneum homogenate. Activity of urokinase was detected after the incubation, but neither the insoluble components of the stratum corneum homogenate nor pro-uPA had any significant urokinase activity. This activation was confirmed by means of Western blotting analysis. After the incubation, pro-uPA had been converted into a two-chain active form.

### PHYSICAL INTERACTION BETWEEN UROKINASE AND THE STRATUM CORNEUM

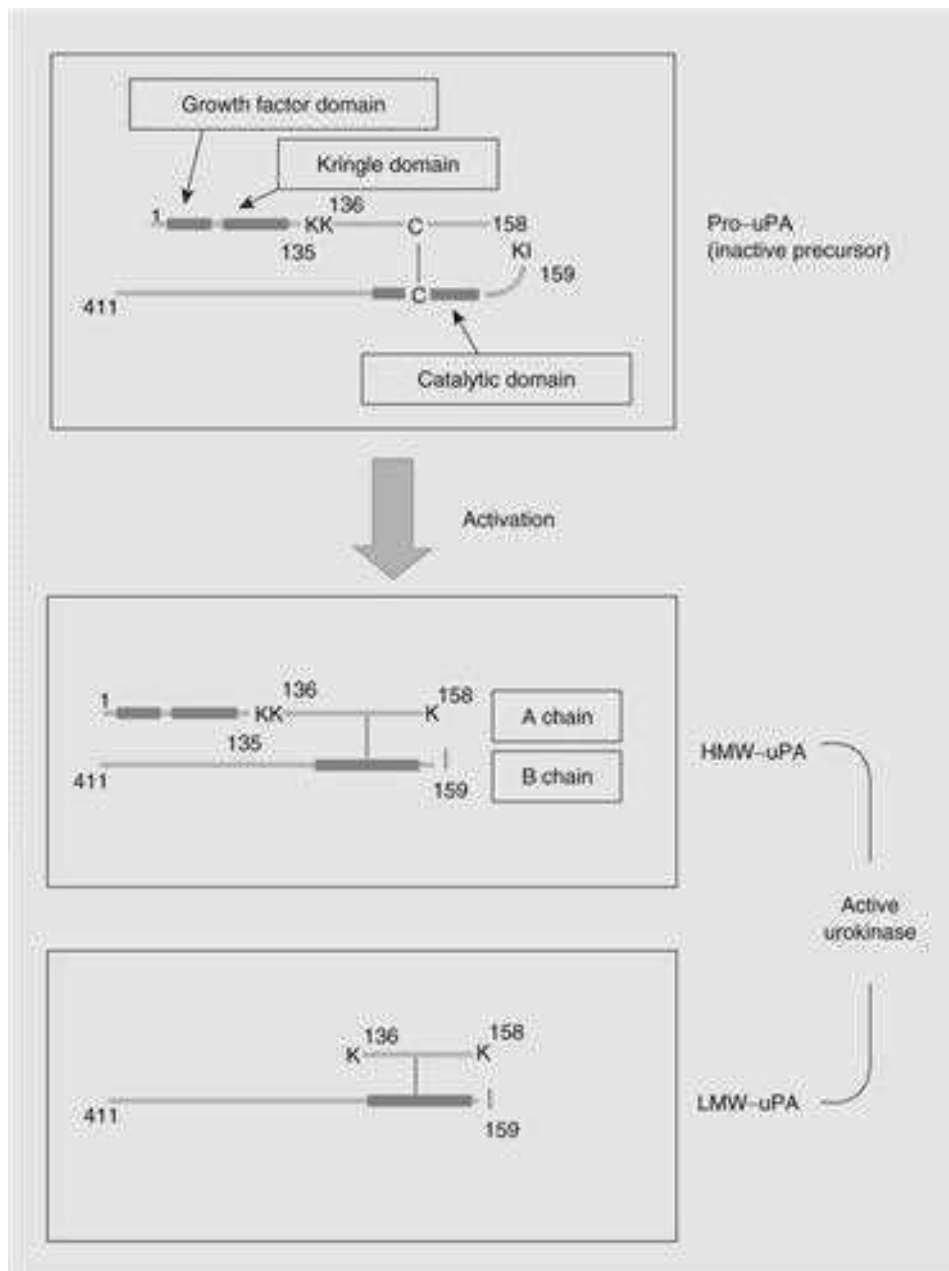
Pro-uPA activation must have taken place on the surface of solid stratum corneum, because only the insoluble components were used in the *in vitro* urokinase activation assay. To estimate the physical interaction between urokinase and the insoluble components of the stratum corneum homogenate, a binding assay was conducted. After incubation of urokinase and the insoluble components of the stratum corneum homogenate, the mixture was filtered to separate the soluble and insoluble components. Amounts of urokinase in both components were determined. Pro-uPA was found to bind to the insoluble components of the stratum corneum homogenate in this assay. This physical interaction is likely to be important for the activation.

The single-chain pro-uPA turns into a two-chain molecule when activated (Fig. 17.2). The N-terminal chain of active urokinase is called the A chain, and contains one growth factor domain and one kringle domain. The C-terminal chain (B chain) includes the catalytic domain. The growth factor domain binds to the urokinase receptor, which exists on the cell surface. The kringle domain is thought to be involved in binding to other molecules, such as insoluble fibrin clot. These regulatory domains in the N-terminal region are thought to function in binding of secreted urokinase to specific molecules.

Urokinase has two active two-chain forms: high molecular weight urokinase (HMW-uPA) and low molecular weight urokinase (LMW-uPA). LMW-uPA lacks the N-terminal 135 residues of HMW-uPA. The growth factor domain and the kringle domain are in this N-terminal region. These two active forms were subjected to the binding assay to estimate the importance of the N-terminal region. HMW-uPA could bind to the stratum corneum homogenate, whereas LMW-uPA could not. Thus, the first 135 residues of urokinase are important for the physical interaction. In the process of dry skin formation, the N-terminal regulatory region of urokinase might bind to some components of the stratum corneum and thereby modulate the enzyme activity.

### *t*-AMCHA METHYLAMIDE

We hypothesized that inhibiting the physical interaction between urokinase and the stratum corneum might be a good way to inhibit activation of urokinase in the stratum corneum. The methylamide derivative of *t*-AMCHA (Fig. 17.4) was used to test this hypothesis. This derivative has less inhibitory



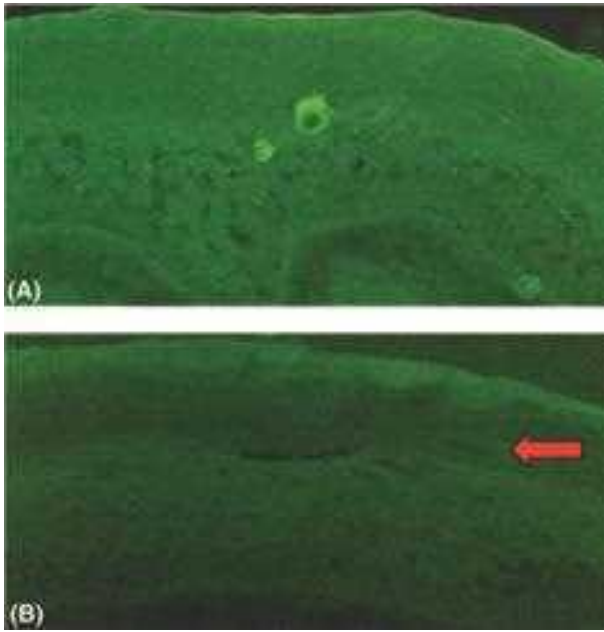
**Figure 17.2** Structure of pro-urokinase plasminogen activator (uPA) and two active forms of urokinase. *Abbreviations:* HMW, high molecular weight; LMW, low molecular weight.

activity against fibrinolysis than the plasmin inhibitor *t*-AMCHA (Fig. 17.5A). Nevertheless, *t*-AMCHA methylamide strongly inhibited the physical interaction between urokinase and the insoluble components of the stratum corneum homogenate in vitro (Fig. 17.5B). It also inhibited activation of urokinase in the stratum corneum in vitro. Addition of *t*-AMCHA methylamide suppressed in vitro pro-uPA activation induced by incubation with the insoluble components of the stratum corneum homogenate.

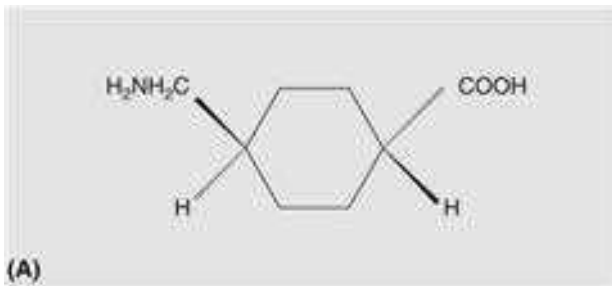
The effects of *t*-AMCHA and the methylamide derivative in preventing dry skin were compared in experimentally induced dry skin (Fig. 17.5C). We found that 1% *t*-AMCHA

methylamide suppressed dry skin more potently than *t*-AMCHA at the same concentration. This result suggested that inhibiting the physical interaction between urokinase and the stratum corneum was more effective in preventing dry skin formation than was inhibiting the activity of plasmin. Inhibition of urokinase activation in the stratum corneum by *t*-AMCHA methylamide in vivo was confirmed by using in situ zymography. The mechanism of suppression of the dry skin formation by *t*-AMCHA methylamide in vivo may be inhibition of the urokinase activation in the stratum corneum.

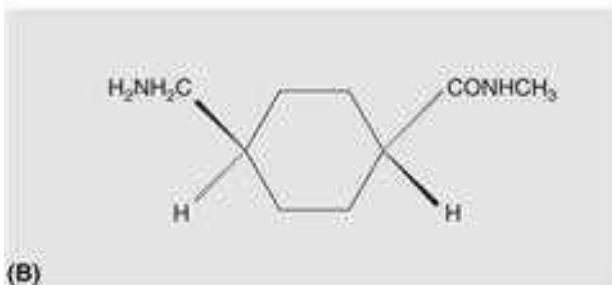
The effectiveness of *t*-AMCHA methylamide in ameliorating naturally occurring dry skin was demonstrated in a



**Figure 17.3** Detection of plasminogen-activator activity in intact skin (A) and skin after barrier disruption (B). Loss of fluorescence indicates plasminogen activator activity. Plasminogen activator activity was detected in the stratum corneum after barrier disruption (arrow).

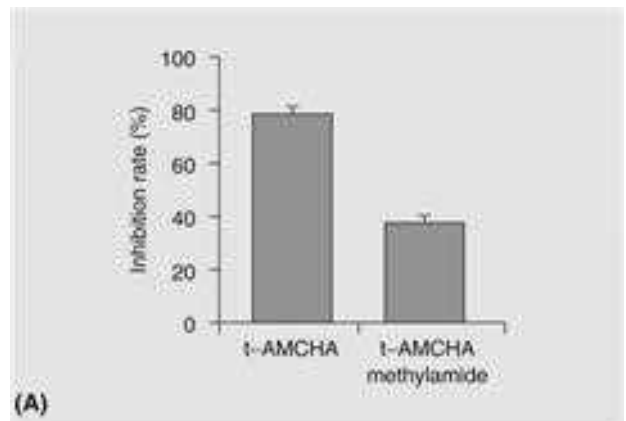


(A)

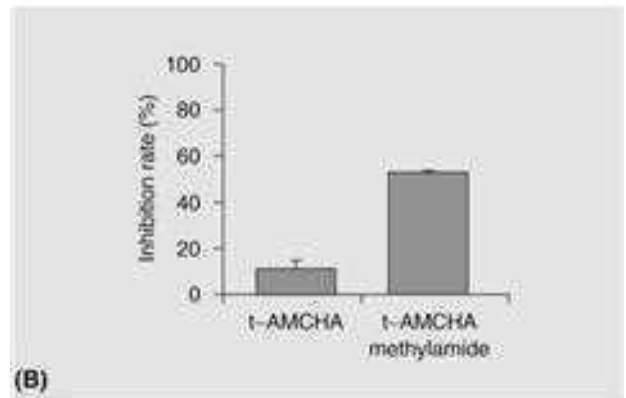


(B)

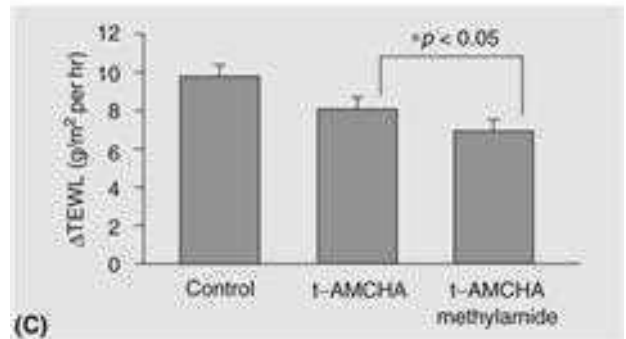
**Figure 17.4** Molecular structures of *t*-AMCHA (A) and *t*-AMCHA methylamide (B).



(A)

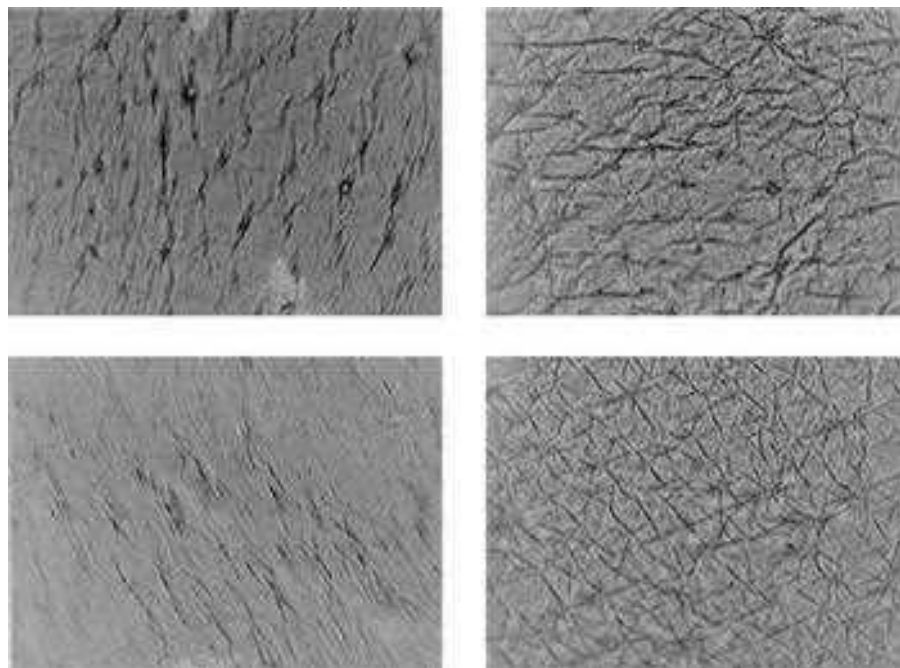


(B)



(C)

**Figure 17.5** Comparison of the inhibitory effects of *t*-AMCHA and *t*-AMCHA methylamide on fibrinolysis (A), the physical interaction between urokinase and the stratum corneum (B), and experimentally induced dry skin formation (C). *t*-AMCHA methylamide (1 mmol/L) had less inhibitory effect on fibrinolysis in vitro than did the same concentration of *t*-AMCHA. However, 1% *t*-AMCHA methylamide inhibited the attachment of high molecular weight urokinase plasminogen activator to the insoluble components of the stratum corneum homogenate more potently than did *t*-AMCHA. Furthermore, 1% *t*-AMCHA methylamide was more effective than *t*-AMCHA on experimental dry skin induced by repeated application of sodium lauryl sulfonate. The compound suppressed the increase of trans-epidermal water loss (TEWL). Whiskers show standard deviations (A, B) and standard errors (C).



**Figure 17.6** The improvement of skin surface texture after one month's treatment with lotion containing 0.7% *t*-AMCHA methylamide in two cases. (*Left*) Skin surface texture before the treatment; (*right*) after the treatment.

double-masked clinical test. After one month's use in winter, lotion containing *t*-AMCHA methylamide significantly improved the skin, compared with the lotion without this compound. The skin surface texture of two cases before and after the treatment is shown in Figure 17.6. It is clear that inhibiting the physical interaction between urokinase and the stratum corneum is an effective method of inhibiting activation of urokinase in the stratum corneum and is a potentially useful approach for preventing dry skin formation (13).

## SUMMARY

As described, dry skin is an important target of skin care. Plasmin is a key intraepidermal secondary factor that induces and accelerates dry skin formation. Urokinase, the enzyme that activates plasminogen in the epidermis of dry skin, is activated in the stratum corneum at an early stage of dry skin formation, and this activation is thought to be the key trigger. Physical interaction between urokinase and the stratum corneum may be important for the activation. Inhibiting this physical interaction to suppress the plasmin system activation in the epidermis is proposed as an effective approach in preventing dry skin formation.

## REFERENCES

1. Kitamura K, Ito A, Yamada K, et al. Potential medication for skin care—focusing on the development of a new effective compound for dry skin. In: Tagami H, Parrish JA, Ozawa T, eds. *Skin: Interface of a Living System*. Amsterdam: Elsevier Science, 1998:151–166.
2. Gall Y, Chappuis JP. Skin care products for normal, dry and greasy skin. In: Baran R, Maibach HI, eds. *Cosmetic Dermatology*. London: Martin Dunitz, 1994:89–110.
3. Kitamura K, Yamada K, Ito A, et al. Research on the mechanism by which dry skin occurs and the development of an effective compound for its treatment. *J Soc Cosmet Chem Jpn* 1995; 29:133–145.
4. Denda M, Kitamura K, Elias PM, et al. Trans-4-(aminomethyl) cyclohexanecarboxylic acid (*t*-AMCHA), an anti-fibrinolytic agent, accelerates barrier recovery and prevents the epidermal hyperplasia induced by epidermal injury in hairless mice and humans. *J Invest Dermatol* 1997; 109:84–90.
5. Zhang L, Seiffert D, Fowler BJ, et al. Plasminogen has a broad extrahepatic distribution. *Thromb Haemost* 2002; 87:493–501.
6. Justus C, Muller S, Kramer MD. A monoclonal antibody recognizing plasminogen and plasmin—altered reactivity in psoriatic lesions. *Br J Dermatol* 1987; 117:687–694.
7. Schafer BM, Maier K, Eickhoff U, et al. Plasminogen activation in healing human wounds. *Am J Pathol* 1994; 144:1269–1280.
8. Jensen PJ, Baird J, Belin D, et al. Tissue plasminogen activator in psoriasis. *J Invest Dermatol* 1990; 95:135–145.
9. Spiers EM, Lazarus GS, Lyons-Giordano B. Expression of plasminogen activator enzymes in psoriatic epidermis. *J Invest Dermatol* 1994; 102:333–338.
10. Grondahl-Hansen J, Lund LR, Ralfkiaer E, et al. Urokinase- and tissue-type plasminogen activators in keratinocytes during wound reepithelialization in vivo. *J Invest Dermatol* 1988; 90:790–795.
11. Romer J, Lund LR, Eriksen J, et al. Differential expression of urokinase-type plasminogen activator and its type-1 inhibitor during healing of mouse skin wounds. *J Invest Dermatol* 1991; 97:803–811.
12. Katsuta Y, Yoshida Y, Kawai E, et al. Urokinase-type plasminogen activator is activated in stratum corneum after barrier disruption. *J Dermatol Sci* 2003; 32:55–57.
13. Katsuta Y, Yoshida Y, Kawai E, et al. trans-4-(Aminomethyl) cyclohexane carboxylic acid methylamide (*t*-AMCHA methylamide) inhibits the physical interaction between urokinase-type plasminogen activator and stratum corneum, and accelerates the recovery of barrier function. *J Dermatol Sci* 2005; 40:218–220.

## Ceramides and the skin

Clive R. Harding, David J. Moore, and Anthony V. Rawlings

### INTRODUCTION

Prevention of desiccation is the major function of the skin. This function is performed for the most part by skin's epidermis, with a particularly crucial contribution by the outer most layers, the stratum corneum (SC). At the skin's surface there is a delicate balance between the water content of the SC and the environment, and although the SC contains relatively little water, a critical level of moisturization is essential for the normal barrier function and health of the skin. To maintain the proper level of moisturization, the skin's epidermis has evolved a finely tuned differentiation program which generates and maintains a SC composed of cellular and macromolecular components that provide the required structure, humectancy and barrier to water loss (1). The SC consists of three basic components; corneocytes (terminally differentiated keratinocytes), corneodesmosomes (proteinaceous rivets holding corneocytes together) and lipids. A widely employed, if oversimplified analogy of SC structural organization is a brick wall (2,3). This analogy provides an image of a heterogeneous structure of two major components: bricks and mortar (Fig. 18.1). In this model, the corneocyte "bricks" occupy most of the volume of the SC wall and are surrounded by a lipid "mortar." It is now recognized that the corneodesmosomes are a vital element of the mortar ensuring structural integrity. Equally, the size and shape of the corneocytes influence skin barrier function as well as the total thickness of the SC. One must also not forget the role of filaggrin and its degraded components (major components of the natural moisturising factor) in SC functioning (1).

The lipid matrix constitutes approximately 20% of the SC volume (about 15% of the dry weight) and is the continuous phase of the skin barrier (4,5). The lamellar bilayer organization of this lipid matrix was first observed clearly using electron microscopy to examine ruthenium tetroxide (RuO<sub>4</sub>) fixed samples (Fig. 18.2A) (6). It has now been well established, using a variety of tape stripping and lipid extraction experiments that the hydrophobic epidermal permeability barrier resides primarily in the lipid bilayers of the SC with the corneocytes and thickness of the SC dictating the tortuosity and thereby increased path length for the diffusion of water through the SC. Consistent with the mortar analogy, however, there is good evidence to indicate that the lipids also contribute to the intercellular cement, which helps to maintain the integrity of the tissue (7,8).

The SC lipid bilayers are unique among biological membranes in terms of composition, organization, and physical properties. The major lipid species of the SC are ceramides (about 50% by mass), fatty acids (10–20% by mass), and cholesterol (25% by mass) (4,5,9). In addition, there are small amounts of cholesterol esters and cholesterol sulfate which, in particular, seems to play a critical role in normal barrier function (10). There

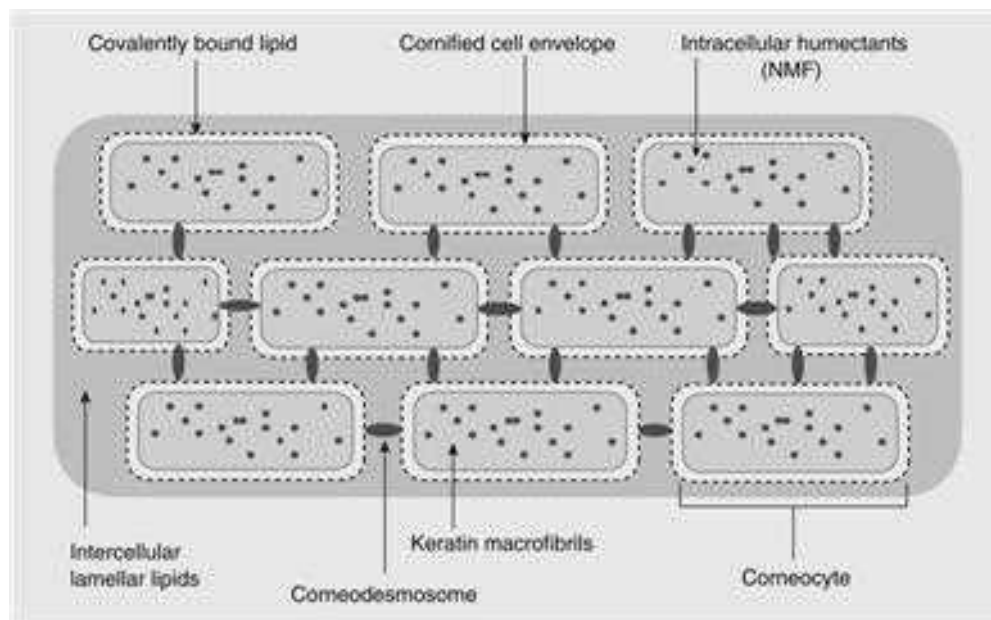
are no phospholipids in healthy SC (5). Many of the lipids of the SC are derived from the contents of the membrane-coating granules (MCG) (also called lamellar bodies or keratinosomes) formed in the keratinocytes of the stratum granulosum, the uppermost layer of the viable epidermis. At the interface between the stratum granulosum and SC the extruded phospholipids, sphingolipids, and plasma membrane constituents are enzymatically cleaved as they enter the SC to generate free fatty acids and ceramides (11). These components then fuse together to form the continuous lamellar bilayers characteristic of the SC (Fig. 18.2B). It is estimated that the skin must synthesize approximately 100 to 150 mg of lipid/day to replace that lost in normal desquamation. The skin, therefore, is one of the most active sites of lipid synthesis in the body (9,12).

This chapter will review recent developments in our understanding of the biological functions of ceramides, the major polar species from which the extracellular lipids of the SC are organized.

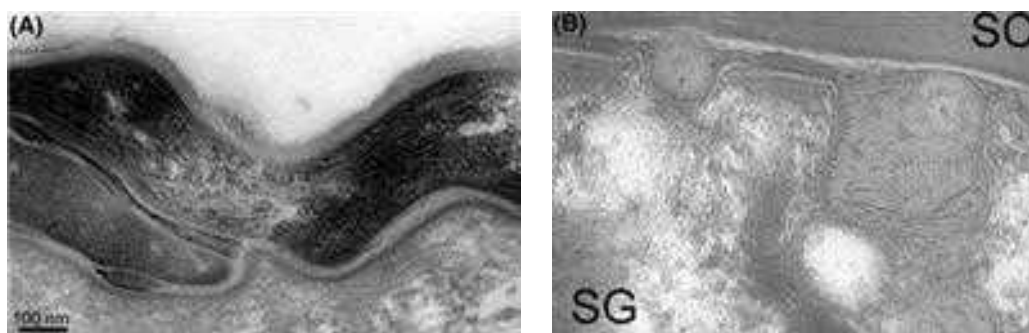
### THE STRUCTURE OF SC CERAMIDES

In recent years our understanding of the heterogeneity of SC ceramides has increased in parallel with the development of new, highly sensitive methodology for their detection and measurement (13,14) and even visualization using specific antilipid antibodies (15). Most notably studies by Masukawa and colleagues employing normal-phase liquid chromatography (NPLC) connected to electrospray ionization mass spectrometry (ESI-MS) have provided new quantitative insights on ceramide classes and species in human SC (16,17).

To date eleven classes of free ceramides (non-corneocyte-bound) have been identified. Their relative abundance in the SC is shown in Table 18.1 (18–20). Collectively these ceramides are derived from three distinct lipid precursor pools synthesized in the underlying epidermis: epidermosides, glucosylceramides, and sphingomyelin. Epidermosides are glycosylated precursors of  $\omega$ -hydroxyl-containing ceramides (21). Studies have shown that both glucosylceramides (MCG content derived) and sphingomyelin (plasma membrane and MCG membrane derived) can contribute to the formation of SC ceramides (22) although evidence suggests that glucosylceramides may represent the major source of ceramide synthesis (23). The epidermosides are precursors to the covalently bound ceramides together with  $\omega$ -hydroxy-containing ceramides (21). The general pathway of ceramide synthesis is illustrated in Figure 18.3. At an initial glance the pathways of ceramide synthesis, transportation and metabolism appears unduly complex and heavily dependent on metabolic resources and energy. However, the intrinsic insolubility of crystalline, high-melting point ceramides, critical for barrier integrity dictates their initial



**Figure 18.1** Schematic representation of the stratum corneum “bricks and mortar” structure depicting the major structural components responsible for the water barrier function and overall tissue integrity. *Abbreviation:* NMF, natural moisturizing factor.



**Figure 18.2** (A) Low-magnification electron micrograph of human SC as a composite structure. Extracellular domains filled with lipid bilayers, and the corneodesmosomes are visualized by ruthenium tetroxide. (B) Electron micrograph of SG-SC interface. Intercellular lipids and cytosolic membrane-coating granules are visualized at the expense of other intracellular structures. *Abbreviations:* SG, stratum granulosum; SC, stratum corneum.

modification to facilitate transport and delivery to the stratum granulosum: SC interface. This is achieved through their glycosylation (glucosylceramide synthetase), or conversion into sphingomyelin (sphingolipid synthetase) and subsequent transportation within MCGs. Once extruded into the intercorneocyte space the mature ceramides must subsequently be “regenerated” through a number of enzymatic processes. The integrity of the barrier function of the SC is therefore critically dependent on glucosylceramide and sphingomyelin synthesis (24).

The chemical structures of the fatty acid and base chains comprising the SC ceramides currently resolved are illustrated

in Figure 18.4, where they are shown in table form following the work of Masukawa and colleagues.

The confusion regarding ceramide nomenclature discussed in the earlier edition of this chapter has now largely been eliminated by the general adoption of a nomenclature based on actual chemical structure rather than on a nomenclature derived from the relative rate of flow (rf) of ceramides measured by thin layer chromatography plates, which has become increasingly meaningless, as it is no longer based on polarity alone. The new nomenclature was first suggested some years ago (19,25) and is gradually becoming more widely adopted in the skin barrier

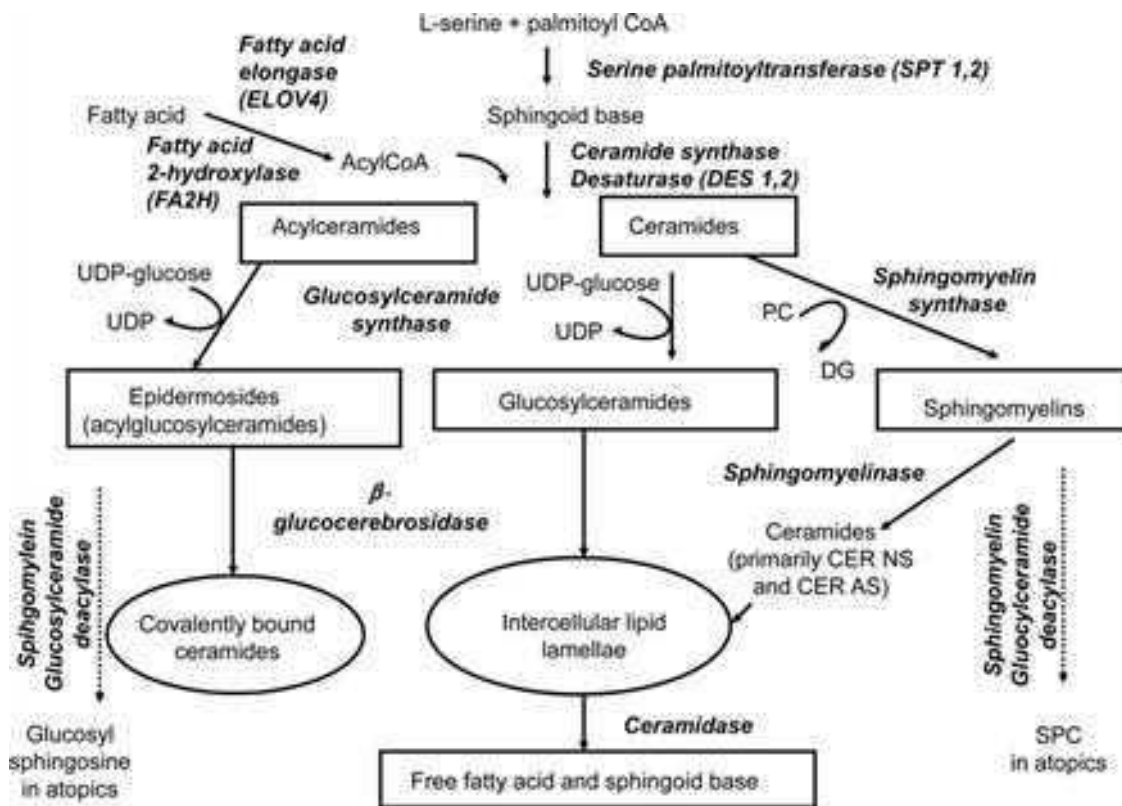
**Table 18.1** Approximate Percentage of Major Free Ceramide Species to Total Ceramide Pool in the Stratum Corneum

Ceramide nomenclature	Percentage of total ceramide
Ceramide (NDS)	6.1
Ceramide (NS)	6.4
Ceramide (NP)	22
Ceramide (NH)	22.5
Ceramide (ADS)	0.8
Ceramide (AS)	3.4
Ceramide (AP)	15.6
Ceramide (AH)	15.4
Ceramide (EOS)	4.2
Ceramide (EOP)	1
Ceramide (EOH)	2.6

literature. We will use the chemical nomenclature throughout this chapter. This nomenclature is based on the molecular structures corresponding to the four sphingoid base chains and three fatty acid chains: sphingosine (S), 6-hydroxy sphingosine (H), dihydrosphingosine (DS), phytosphingosine (P),  $\alpha$ -hydroxy acid (A), nonhydroxy fatty acid (N), and esterified  $\omega$ -hydroxy fatty acid (EO). The complete molecule is designated by "ceramide (CER-acid-base)," that is, the acid chain abbreviation precedes the base chain (in the case of an ester link in the acid chain, this is noted first). For example, a 6-hydroxy sphingosine with an  $\alpha$ -hydroxy

fatty acid chain would be denoted as CER[AH]. The 12 ceramide classes possible from these combinations of acid and bases are listed in Figure 18.4, the relative concentration of each class is listed in Figure 18.1. However, it should be noted that CER [EODS] has yet to be identified within the SC lipids.

Human SC ceramide base chains range from 18 to 22 carbons in length (12,18,26). For the nonhydroxy fatty acid ceramides the amide linked fatty acid chains range from 16 to 32 carbons in length with the major chain species being either 24 or 26 carbons (18,25). For the  $\omega$ -hydroxy ceramides (CER [EOS] and CER[EOH]) the fatty acid chains range from 30 to 34 carbons in length with linoleic acid (C18:2) esterified to the  $\omega$ -hydroxy group (19,27). The ongoing analytical work of Masukawa and colleagues evaluating SC ceramides is refining the above values although these new results appear to be in general agreement (16,17). One point of interest is the identification of several odd-numbered fatty acid chains in SC ceramides and the suggestion of branch chained; these initial studies await further confirmation. Using NPLC-ESI-MS methods over 300 distinct ceramide species have been identified across the classes illustrated in Figure 18.4 (17). Further improvements in these techniques appear set to herald in the dawn of ceramide lipidomics; enabling precise changes in these species associated with body site, increasing age, gender, ethnic differences and varying skin conditions to be elucidated through minimally invasive procedures (adhesive tape stripping).



**Figure 18.3** Summary of the proposed pathways leading to synthesis of stratum corneum ceramides. Enzymes are shown in bold italics. Abbreviations: PC, phosphatidylcholine; DG, diacylglycerol; UDP, uridine diphosphate; SPC, sphingosylphosphorylcholine; SPT, serine palmitoyl transferase; CER, ceramide.

Fatty Acid			
Sphingoid	Nonhydroxy fatty acid [N]	$\omega$ -Hydroxy fatty acid [A]	Esterified $\omega$ -hydroxy fatty acid [EO]
Dihydrosphingosine [DS]	CER[NDS]	CER[ADS]	CER[EODS] [Not yet identified in SC]
Sphingosine [S]	CER[NS]	CER[AS]	CER[EOS]
Phytosphingosine [P]	CER[NP]	CER[AP]	CER[EOP]
6-Hydroxy sphingosine [H]	CER[NH]	CER[AH]	CER[EOH]

**Figure 18.4** Structures of the major free ceramide classes of human SC. The structure of the major covalently bound species CER[OS] and CER[OH] results from hydrolysis of the acyl fatty acid from CER[EOS] and CER[EOH], respectively. *Abbreviations:* CER, ceramide; SC, stratum corneum.

Although not the focus of this chapter it is worth noting the chain length of SC free fatty acids are approximately C22 (11%), C24 (39%), C26 (23%), and C28 (8%) (28). The unusual physical properties of the SC lipid bilayers, compared with other biological membranes, are in large part due to these long, primarily unsaturated, hydrocarbon chains that characterize both the ceramides and the fatty acids. The critical importance of very long-chain fatty acids (VLCFA) is emphasized by mutations in the enzymes (elongases) responsible for their synthesis. Mutations in the elongase, ELOVL4, are associated with the Stargardt-like macular degeneration. Deliberate deletion of ELOVL4 in murine models lead to profound barrier defects characterized by a global decrease in VLCFA in the free fatty acid, ceramide, and glucosylceramide fractions (29,30). Strikingly, the SC is devoid of CER[EOS] and CER[EOH]. Similarly, synthetic short-chain ceramides (based on CER[NS]) with a four- to eight-carbon acyl chain have been shown to dramatically increase SC permeability. The disruption to barrier was maximal with a C6 acyl chain, whereas C2 and C12 ceramides did not increase permeability (31). In contrast, others have demonstrated that short-chain ceramides, including those with a C6 acyl chain, increase keratinocyte differentiation (32,33).

Certain ceramides are covalently bonded to the outside aspect of the corneocyte protein envelope via the formation of ester linkages between hydroxyl groups on the ceramides and carbonyls of the  $\beta$ -sheet proteins of the cornified cell envelope

(34,35). This process appears to be catalysed by transglutaminase 1 (36), a calcium-requiring enzyme previously thought to be involved solely with protein crosslinking *within* the cornified envelope. The lipid envelope consists primarily of CER[OS] (ceramide A) the derivative of CER[EOS] and CER[OH] (ceramide B) the derivative of CER[EOH], see below and Figure 18.4 for ceramide structures. Two novel species of covalently bound ceramides have been identified one consisting of a sphinganine base (C17–C22), the other displaying a phytosphingosine base and both linked to  $\omega$ -hydroxy acid; designated CER[OSP] and CER[OP], respectively (20). Downing suggests that all the  $\omega$ -hydroxy ceramides of corneocyte lipid envelopes are attached to proteins through their  $\omega$ -hydroxyl groups (37).

It has been determined that there is enough lipid covalently attached to the corneocyte protein envelope to form a complete lipid monolayer over the surface of each cell (5,34). The very long chains of the envelope ceramides lipids will be conformationally ordered thereby forming a water barrier around each corneocyte (34), and studies in mice suggest that the amount of covalently bound ceramide is highly correlated with the barrier function of the skin (38). A critical function of this layer, is to cover the corneocytes with a lipophilic coating and thereby act as a template or scaffold to direct the assembly of the extruded lamellar body lipids into lamellar bilayers (4,5). Severe abnormalities to MCG formation, lipid organization and barrier function result from the topical application of a specific inhibitor of  $\omega$ -hydroxylation emphasizing the important role



this class of ceramides plays in barrier formation and integrity (39).

Although the majority of ceramides with the SC remain intact during SC maturation, ceramide-hydrolyzing enzymes have been identified in the SC, and these may be responsible for the formation of ceramide degradation products readily identified within the tissue (40). A lipid species called acyl acid, which appears to be the  $\omega$ -esterified *N*-acyl fatty acid portion of CER[EOS], and free sphingoid bases were shown to be present in human epidermis (41,42). It is possible that both of these lipid species could be derived from hydrolysis of CER[EOS] or acylglucosylceramides. Although the role of these degradation products is uncertain, sphingosine and other sphingoid bases may be involved in a SC-epidermis signaling function as these have been reported to inhibit keratinocyte proliferation (43). It has been shown also that sphingosine is a potent antimicrobial and its presence in the SC may well form part of the skins defense against invading microorganisms (44). Similarly, it has been reported that phytosphingosine has both antimicrobial and anti-inflammatory properties and has demonstrated potential to enhance existing antiacne therapies (45).

### LIPID ORGANIZATION IN THE SC

The lamellar bilayer of most biological membranes consists of lipids in the liquid crystalline ( $L_{\alpha}$ ) state. In this state the lipid chains have considerable intramolecular conformational disorder. Aliphatic liquid crystal forming lipids can undergo reversible transitions between the lamellar gel phase ( $L_{\beta}$ ) and the lamellar  $L_{\alpha}$  phase. In the  $L_{\beta}$  phase, hydrocarbon chains are in a fully extended all-*trans* conformation and the chains are packed in a hexagonal array. Long-chain lipids can also pack lamellar bilayers where the chains are packed in an orthorhombic array. In this phase the chains are conformationally order and packed in a very tight crystalline array (46).

Our understanding of lipid organization in biological membranes has advanced significantly in the last two decades as a variety of biophysical techniques have shed light on the molecular details of membrane lipid organization and dynamics. A consequence of this research has been the considerable modification of the original "fluid mosaic" model of cell membrane organization as the paradigm for membrane lipid organization (47). Thus lipid domains across cell membrane bilayers as well as within the plane of membrane leaflets have been observed in a variety of biological membranes (48–50). The complexity of the lipid composition of the SC, as well as its unusual physical properties clearly indicates a unique molecular organization. The very long carbon chain lengths of SC ceramides and free fatty acids are, no doubt, the primary determinant of the unusual (for a biological membrane) physical properties of the SC lipid bilayers. In recent years a variety of biophysical studies utilizing techniques such as nuclear magnetic resonance (NMR), X-ray spectroscopy, differential scanning calorimetry (DSC), and Fourier transform infrared (FTIR) spectroscopy have presented a detailed molecular level picture of lipid organization in the SC.

A variety of published reports have established that the hydrocarbon chains of SC lipids are highly ordered. McIntosh and coworkers, in X-ray studies of mixtures containing ceramides, fatty acids, and cholesterol, observed ordered gel phase lipids at 25 mol percent cholesterol, which did not depend on the amount of water present, or on the presence of protein (51). The repeat unit of 13 nm in these studies was postulated to

arise from two bilayers. In earlier wide-angle X-ray studies of murine SC, White and colleagues reported the presence of some crystalline orthorhombic lipids at physiological temperature (52). Orthorhombic phase lipids have also been observed by Bouwstra and coworkers in X-ray studies of isolated human SC as well as in recent electron diffraction studies of ceramide/cholesterol/fatty acid models of SC (53–55). In addition, Bouwstra and colleagues have demonstrated the importance of CER[EOS] in producing the intermolecular organization necessary for healthy skin barrier function (56).

In one of the authors laboratory (DJM) experimental infrared spectroscopy techniques have been developed to measure lipid organization in lipid bilayers, cell membranes, and living cells (57–59) to explore the molecular behavior of diverse ceramide species, both alone and in lipid models of the SC (60–63). This work has demonstrated that each ceramide species organizes somewhat differently, reflecting distinct intermolecular interactions between their hydrocarbon chains as well as significant headgroup hydrogen bonding interactions. It is quite feasible that good overall cohesion in the SC, and therefore good barrier function, is provided by the diverse physical properties of these heterogeneous species.

CER[EOS] is worthy of particular mention. This is the predominant ceramide containing unsaturated fatty acids in the SC and it is remarkably enriched in linoleic acid, which comprises a minimum of 20% to 30% of the  $\omega$ -esterified fatty acid. The epidermis has an absolute requirement for linoleic acid to maintain a correctly functioning barrier and its absence leads directly to the dramatically perturbed barrier found in EFAD animals. The characteristic hyperproliferation seen in this condition may also reflect further perturbation in linoleic acid metabolism (64).

As the work of Bouwstra and coworkers, and others has suggested this particular ceramide species provides unique physical properties to the SC (56,65) that simply cannot be compensated for by the esterification of other unsaturated fatty acids within the CER[EOS] fraction. As we will discuss later in this chapter reduced levels of CER[EOS] containing linoleic acid is a feature common to many skin disorders including acne, atopic dermatitis and winter xerosis.

In contrast, increases in CER[EOS] are a feature of the response of skin to repeated surfactant challenge (the so-called "hardening phenomenon") again emphasizing the key role this ceramide plays in skin protection (66).

The careful interpretation of many *in vitro* and *in vivo* investigations on lipid behavior in the SC has led to several models being proposed to describe lipid organization in this structure. Some models are more theoretical/hypothetical, such as Forslind's "domain mosaic" model (67) and Norlen's related "single gel phase" model (68), whereas others are based on selected empirical data, such as Bouwstra's sandwich model that relies primarily on X-ray diffraction data (69). A detailed analysis and discussion on the relative merits of each model is beyond the scope of this review. Since the last edition of this chapter there has been no new models proposed for SC lipid organization. The continued observation of orthorhombic lipid organization from both *ex vivo* and *in vivo* SC measurements (70,71) are consistent with many model SC studies, and suggest the single gel phase model is not an adequate description of barrier lipid organization.

Although the prime function of lipids in the SC is that of providing the water barrier, lipid abnormalities associated with altered cornification have been reported in many common

dermatological disorders (psoriasis and atopic dermatitis). Structural abnormalities in SC lipid lamellae also occur in the outer layers of the SC in dry skin. However, at present there is not a detailed understanding of how changes in the lipid composition, or specifically the ceramide composition, influence corneocyte cohesion and ultimately desquamation. There is indirect evidence for SC lipids being involved in cell cohesion from corneocyte reaggregation studies *in vitro*. Numerous workers have reaggregated previously dispersed corneocytes in the presence of SC lipids and found the physical properties of the reconstituted SC lipid cell films to be similar to the intact tissue (72,73). In marked contrast, Chapman et al. (74) suggested intercellular lipids might actually have an anticohesive role preventing close opposition of adjacent corneocytes. In those particular studies, when SC lipids were completely extracted, the intercorneocyte forces were dramatically increased, primarily because of the juxtaposition of the covalently bound lipids and corneocytes became tightly cohesive. Taken together these observations indicate that both the intercellular and covalently bound lipids may have a role in SC integrity.

Changes in physical properties of the SC ceramide lipids may also be important in promoting cell dyshesion toward the skin surface. It is known that the fine ultrastructure of the ceramide bilayers is disturbed in the superficial layers in normal skin (75). This loss of structure, critical for normal desquamation, may reflect hydrolysis by ceramidases (40). Alternatively there is evidence that surfactant-like sebaceous fatty acids may lead to bilayer disruption (76) and the induction of an orthorhombic to hexagonal structure transition at the surface of the SC (77).

Ultimately, however, it is the corneodesmosome, which is primarily responsible for intercorneocyte cohesion (75,78,79), and it is this structure which must be effectively hydrolyzed to ensure desquamation. Ceramides, together with other lipid species, may play an important role in this process. Although the precise mechanism is far from understood, the phase behavior and organization of the intercellular lipids controls the water content in the SC, and may influence the activity of the hydrolytic enzymes (80) present within the intercellular space which are responsible for corneodesmosomal degradation. In this respect it is of interest to note that the action of ceramidase in releasing free fatty acids may also contribute to the acidification of the SC that is critical for enzymatic regulation, normal desquamation and barrier function (81).

## VARIATIONS IN SC CERAMIDE LEVELS

The total amount of ceramides in SC, as well as individual ceramide species, are influenced by disease and hormonal status, diet, age, race, external environment, and by circannual variation. Ultimately, it is the ratio of the different lipid classes as well as the levels of individual lipids in the SC that influence barrier function, water content, and skin condition. These differences can be subtle, that is, changes in the crucial ceramide:cholesterol ratio may explain the altered barrier characteristics in axillary skin (82). In this section we review specifically the changes in ceramide composition characteristic of various skin disorders.

### Psoriasis and Lamellar Ichthyosis

Of the genetic diseases impacting skin condition, only lamellar ichthyosis and psoriasis have been investigated in any detail in relation to the levels of SC ceramides. In both of these conditions

dramatic changes in SC lipid structure is observed reflecting changes in lipid composition (83–85). These changes include increases in CER[NS], CER[EOH], and decreases in CER[AS]. Together with the altered cholesterol and fatty acids levels, these alterations contribute toward some of the aberrations in SC function which are characteristic of these conditions, including corneocyte cohesion and faulty desquamation. Individuals suffering from lamellar ichthyosis have a defective gene for transglutaminase 1. As we have seen earlier the inability to link ceramides to the cornified envelope has dramatic consequences for the skin and the loss of this enzymatic function explains in part the dramatic skin phenotype seen in ichthyotic individuals. It has also been reported that the composition of the covalently bound lipids differs in psoriatic SC compared with healthy SC. In psoriatic skin, CER[OH] decreases, while other components such as  $\omega$ -hydroxy acids and fatty acids, particularly the covalently bound oleate and linoleate, are seen to increase (27). Recent focused studies on the discrete enzymes involved in the synthesis and degradation of ceramide have suggested that serine palmitoyl transferase (SPT), the rate-limiting enzyme in ceramide biosynthesis is significantly decreased in lesional and nonlesional sites (86). The same authors also report on a negative correlation between the levels of this enzyme and the PASI score.

Over the past five years the genetic basis of the congenital scaling syndrome harlequin ichthyosis has pointed to the importance of mutations in a member of the ABCA transporter family, ABCA12. Mutations in this gene lead to an abnormality in lamellar body formation, perturbed lamellar lipid organization in the SC and loss of barrier function (87). These barrier perturbations are associated with profound decreases in the long-chain  $\omega$ -hydroxyl ceramides (CER[EOS]) and a corresponding increase in glucosylceramides (88). Understanding of molecular mechanisms indicates that epidermal ceramides may regulate ABCA12 gene expression through a peroxisome proliferators-activated receptor (PPAR)- $\delta$ -mediated signaling pathway (89). Although the SC lipid profiles in other ichthyotic diseases have not been fully determined, reduced levels of sphingosine have been found in a variety of subjects with various ichthyoses (90). This decrease in sphingosine may, in part, explain the cellular hyperproliferation observed in these conditions as sphingosine, has been proposed to feedback to the epidermis and downregulate keratinocyte turnover (43).

### Atopic Dermatitis

Atopic dermatitis is characterized by xerosis and reduced barrier function as measured by transepidermal water loss (TEWL) and corneosurfametry. This condition is also associated with a significant decrease in SC ceramide levels (91,92), particularly, CER[EOS] containing linoleic acid (93), and the presence of unusual, possibly diagnostic ceramide species (94). Research over the past 15 years has emphasized that many aspects of lipid metabolism are deranged in this condition; atopics has significantly depleted covalently  $\omega$ -hydroxy ceramides (95), and reduced levels of prosaposin, an important regulator of sphingolipid metabolism (96).

The lowered level of ceramides in atopics has been linked to reduced activity of sphingomyelinase (97) and an altered (increased) expression of the enzyme sphingomyelin deacylase (98,99). This enzyme competes with sphingomyelinase for the ceramide precursor sphingomyelin. Although sphingomyelinase remains active in atopics (100) significant levels, of sphingomyelin are hydrolyzed by this alternative pathway to release

free fatty acid and sphingosyl phosphoryl choline (SPC). The same enzyme can also degrade glucosylceramides to release glucosylsphingosine (GS), that is, it also possess glucosylceramide deacylase activity (101).

The presence of SPC may partially explain the inflammation associated with this disorder as it is a potent modulator of epidermal function, stimulating proliferation and upregulating plasminogen activator (102). The vulnerability of the SC of atopic patients to colonization by *Staphylococcus aureus* may reflect the reduced levels of sphingosine present in the tissue in turn reflecting the decreased levels of ceramide (substrate) and the diminished activity of its metabolic enzyme acid ceramidase (103).

### Acne

Alterations in lipid species are evident in acne. Downing et al. (104) found reduced proportions of linoleate bound to CER [EOS] in acne patients and postulated that this reflected a localized decrease in the bioavailability of the essential fatty acid due to a dilution effect of increased sebum production. Yamamoto (105) has shown that the general decreases in both ceramides and free sphingosine in acne patients correlates to diminished water barrier function. Therefore, altered barrier functionality leading to epidermal hyperkeratinization and poor desquamation within the follicular epithelium may be responsible for comedone formation in susceptible individuals.

### Dandruff

Studies in one of the author's laboratory (CRH) (106) have demonstrated that in dandruff sufferers the intercellular lipid content of scalp SC, including ceramides, is dramatically reduced compared with healthy subjects. This depletion is associated with reduced barrier function, which may leave dandruff sufferers more prone to the adverse irritant effects of microbial metabolites, surfactants or pollutants present on the scalp surface. These observations are consistent with recent studies that indicate the presence of a perturbed lipid ultrastructure in dandruff sufferers (107). Effective use of antidandruff treatments is accompanied by increased lipid levels including ceramides (108).

### Senile Xerosis

It is widely experienced that as we age we suffer from more skin problems. Although these problems arise from a combination of many factors, an age-related reduction in the levels of SC ceramides may contribute to senile xerosis and other skin conditions. Age-related declines in SC ceramide have been reported in both Japanese (109) and Caucasian subjects (110,111). In the latter study, although the relative levels of the main ceramide subtypes did not change, overall SC lipid levels diminished with increasing age on face, leg and hand skin. In addition, the same group reported an age-related decline in CER[EOS] linoleate levels, which may have a dramatic effect on SC barrier function (112). In another study with French Caucasians, a selective depletion of sterol esters and triglycerides, but not ceramides, was reported in ageing leg SC (113). Researchers, at L'Oreal have used high-performance liquid chromatography coupled with ESI-MS to elucidate ceramide change in dry skin. They report that phytosphingosine-containing ceramides are particularly depleted in dry skin compared with sphingosine-containing ceramide species (114).

Moreover shortening and lengthening of the acyl sphingoid bases sphingosine and 6-hydroxy sphingosine have been reported in dry skin (114).

Ceramide subtypes have also been reported to change with age in Japanese women (109). Surprisingly, increases in CER [EOS] but decreases in CER[NP] and CER[AP] were found going from prepuberty to adulthood. These studies and others suggest that the impact of age on ceramide levels is likely to be influenced by ethnic background. For instance, in comparing SC lipid levels in several racial groups, Sugino and coworkers (115) reported that SC ceramide levels were lowest in African Americans compared with other racial types. Paradoxically African American skin is often viewed as being relatively resistant to damage, emphasizing the fact that the resilience of the skin barrier is determined by many factors including the size of the corneocytes and the thickness and integrity of the SC although these factors were not discussed by these authors. For a more detailed consideration of ethnic skin differences see (116).

The most likely cause of an age-related decline in lipid levels is a reduced epidermal lipid biosynthesis capability as reported by Ghadially et al. (117). The increased activity of ceramidase reported by Akimoto may also contribute to declining ceramide levels (118). Studies in aged mice have shown reduced levels of epidermal acid sphingomyelinase and ceramide synthase consistent with a reduced age-related capacity to repair the barrier. In this study ceramidase did not show any age-related change (119). Further work is needed to extend and confirm these changes in man.

Although considerable progress has been made, our understanding of the influences of race, gender, and age on SC lipids remains incomplete. There is a large intraindividual difference in lipid levels without obvious physical manifestations of dryness (120). Similarly in aged dry skin the demonstration of an altered lipid composition or differing molecular organization is not always apparent. Clearly, clinical dry skin is not monocausal and many other factors contribute to the phenotype (1). Nevertheless, and once again emphasizing the importance of the  $\omega$ -hydroxy fatty acids, a deficiency of CER [EOS] and CER[EOH] is frequently correlated with an absence of the long-periodicity phase (LPP) as examined by X-ray diffraction in the dry skin disorder (65).

### Effects of Environmental Factors on the Expression of Winter Xerosis

It has become apparent that many factors influence the levels and types of SC lipids, and it is possible that their reduction leads directly to poor skin condition. Levels of lipids differ on different body sites, which may make those sites more or less prone to environmental damage (121). For instance, lower levels of SC lipids will be more susceptible to extraction (e.g., during hand washing) or perturbation of their structural organization which could lead to abnormalities in SC function and overall skin condition leading to a visibly dry and flaky skin surface. Indeed, a picture is emerging that lipids influence the expression of this common problem. Lipids are easily extracted from the SC by solvents (122) and surfactants (123), leading to their depletion from the intercellular spaces of the SC, and resulting in skin scaling. In studies employing aggressive acute treatment regimes, solvents and surfactants extraction leads to changes in the relative amounts of the different lipid species in the outer layers of the skin, due to selective removal of lipids. However, during chronic treatments, particularly

with surfactants, differences in SC lipid composition, but not total lipid levels, have been reported (124). Following chronic exposure to surfactants, increases in CER[EOS] and CER[NS] and cholesterol were observed, whereas remaining ceramides, cholesterol esters, long-chain fatty acids all decreased in concentration. Similar changes in SC ceramide profiles have been reported in other experimental models for scaly skin (e.g., tape stripping), indicating that the changes in SC lipid composition are related to changes in epidermal lipid biosynthesis rather than lipid extraction from the SC (125). In skin suffering from soap-induced winter xerosis, the total levels of SC ceramides are decreased (110,126,) and the levels of fatty acids are increased (126,127).

Although the effects of climate on skin condition are well known, there have been very few studies examining circannual variation in SC lipids. An early study has shown a general decrease in epidermal cerebrosides in winter compared with summer (128). Following the analysis of SC lipids from the face, hand and leg skin of female Caucasians in the winter, summer and spring months of the year Rogers et al., reported decreases in all major lipid classes on all body sites during the winter months (111). Although the levels of ceramide subtypes were unchanged, the amount of linoleate esterified to CER[EOS] was reduced. These changes are likely to result in reduced barrier function. For instance, an increased susceptibility to treatment with SLS has been reported for the winter months of the year (129), and an inverse correlation has been shown between ceramide levels and TEWL following an SLS patch (130).

Xerosis is not confined to winter and studies conducted almost 20 years ago reported that there were changes in ceramides associated with UV damage. Recently murine studies have indicated that there are dramatic differences in ceramide-relevant enzymatic activity during the early response to UVB. Glucosylceramides accumulate in the SC, because of attenuated activity of  $\beta$ -glucocerebrosidase (131), and decreased levels of covalently bound lipids are measured potentially because of downregulation of transglutaminase 1 (132). These and changes in other enzymes associated with lamellar body formation and organization will contribute to the reduced barrier function and scaly skin characteristically seen post UV irradiation.

During the past 15 years the pioneering studies by Denda and coworkers have begun to elucidate just how seasonal low humidity can influence epidermal processes and lead to disturbances in barrier function. The observation that low environmental humidity stimulates epidermal DNA synthesis, and amplifies the hyperplasia associated with barrier damage (133) has helped to rationalize the characteristic seasonal exacerbation of inflammatory dermatoses. Perturbations to mast cell physiology have suggested the use of H1 and H2 histamine receptor antagonists to improve overall skin condition (134). The reader is referred to a recent review by Denda that explores several new strategies to improve barrier homeostasis (135).

## **BIOSYNTHESIS OF SC CERAMIDES AND BARRIER REPAIR**

### **Endogenous Regulation of Ceramide Synthesis and Barrier Function**

Elias and coworkers developed several models of barrier repair to decipher the biochemical control mechanisms of barrier homeostasis (136). When the SC barrier is damaged, a series of homeostatic processes are immediately accelerated and, in the absence of further damage, the barrier recovers to its original

level. These processes include lipid biosynthesis, lipid processing and the acceleration of the exocytosis of lamellar bodies. Although altered water flux is a key factor in initiating barrier repair following SC perturbation (137) the precise signal is not understood. Moreover, it should be noted that many of these studies were conducted on murine models and may not necessarily reflect the situation in human skin (138).

Studies using inhibitors to the key rate-limiting enzymes have indicated that all major species of SC lipids are synthesized during barrier repair and all are required for full barrier homeostasis. In contrast to the synthesis of cholesterol and fatty acids, which increase almost immediately after barrier disruption, synthesis of glucosylceramides, the precursors of the SC ceramides, is delayed until approximately seven hours later (139). It is possible that the synthesis of the other lipids occurs more quickly as the rate-limiting enzymes (hydroxy methylglutaryl CoA reductase and fatty acid synthetase) involved in their synthesis are subjected to acute metabolic control mechanisms, such as phosphorylation. SPT, (see previous section) is not subjected to such control and requires the transcription and translation of further enzyme (140). Furthermore, recent studies on transcriptional control of lipid synthesis in mammalian cells has shown that the expression of genes involved in cholesterol and fatty acid synthesis and uptake is regulated by the sterol regulatory binding proteins (SREBP 1 and 2). In contrast ceramide synthetic machinery does not appear to be regulated by this system (141).

Studies on animal models (39) have emphasized that hydrolysis of the glycosylated ceramide precursors by  $\beta$ -glucocerebrosidase is a critical step in correct barrier formation and repair, and once again activity of this enzyme is regulated by barrier permeability (142). Although factors controlling the synthesis and activity of this enzyme are poorly understood, there is evidence emerging that the saposins (sphingolipid activator proteins) are intimately involved. This class of proteins stimulates enzymatic hydrolysis of sphingolipids including glucosylceramide and is essential for epidermal barrier permeability barrier formation and maintenance (143). Pro-saposin is reported to be depleted in certain skin disorders (96,144). Many studies have indicated that ion flux plays a critical role in barrier homeostasis, and there is a drastic alteration of calcium gradient following barrier insult (145). It is possible that regulation of calcium ion dynamics after the barrier damage might control the skin barrier homeostasis (146). Mixtures of magnesium and calcium salts have been shown to accelerate skin barrier recovery and improve surfactant- or tape stripping-induced dry skin (147). Although such studies indicate the importance of these ions for epidermal homeostasis more work is needed with cosmetic formulations. Nevertheless, on the basis of these observations recent work has demonstrated that manipulation of ligand-gated ion channels can influence barrier recovery.  $\gamma$ -Aminobutyric (GABA) type A receptor agonists, musimol and isoguvacine; accelerate barrier recovery following barrier disruption (148). Conversely, ATP (purinergic) receptor (P2X) agonists delay barrier recovery whereas P2Y antagonists accelerate it (149). These molecules also reduced the epidermal hyperproliferative response induced by acetone treatment under low environmental humidity.

Importantly, a variety of cytokines are released/secreted by the epidermis during barrier repair and they equally may contribute as key lipid biosynthetic switches in barrier development and barrier homeostasis (150–152).

### Influence of Topically Applied Ceramides on SC Barrier Function

Imokawa and coworkers were the first to investigate the effects of topical application of human SC ceramides to solvent and surfactant-induced scaly skin (122,123). When the extracted lipids, and in particular the ceramide fraction, were applied back to the damaged skin, reductions in scaling and improvements in skin moisturization, as measured by skin conductance, were observed. This amelioration of skin condition was superior to placebo and corresponding formulations containing sebaceous lipids. In these studies the ceramides were either solubilized in squalene or emulsified in water in oil cream containing monomethylheptadecylglyceryl ether. Interestingly, these effects were not observed without the glyceryl ether. Although the glyceryl ether may be aiding penetration of the ceramides into the SC, it is also likely that it influences SC lipid phase behavior. Agents such as glycerol and glyceridacid are known to influence the physical properties of the ceramide containing SC lipids.

Beradesca et al. (153) and Linter et al. (154) have demonstrated that exogenously supplied CER[EOS] and CER[NS], respectively, reduced the detrimental effects of SLS on disturbing skin barrier function. Chamlin (155) has reported that a ceramide dominant barrier repair cream helped to alleviate atopic dermatitis over a six-week period. However, the title was incorrect in this paper as a pseudoceramide was actually used *N*-(2-hydroxyethyl)-2-pentadecanoylhexadecanamide (Y. Uchida, personal communication). Studies by Imokawa and coworkers have reported on the skin condition benefits derived from topical application of formulations containing 5% to 8% synthetic ceramides (so-called pseudoceramides) that mimic the physical properties of SC ceramides (156). Many laboratories continue to examine novel, synthetic ceramide structures for both improved keratinocytes differentiation and impact on barrier repair (157,158).

Invariably, optimal improvements in dry and damaged SC are observed when complete lipid mixtures are topically applied. De Paepé observed that a mixture of ceramides (CER[NP] and CER[AS]), together with cholesterol, linoleic acid, and phytosphingosine provided significant improvements in barrier function and hydration over use of ceramides alone (159). Elias and coworkers have also focused on the use of exogenously supplied lipids to repair water barrier function (160,161). Although equimolar mixtures of ceramides, cholesterol, and fatty acids allow the barrier to repair at normal rates, an optimized mixture (cholesterol, ceramide, palmitate, and linoleate: 4.3:2.3:1:1.08) was noted to accelerate barrier repair following disruption of the murine water barrier by acetone. Although this mixture was seen to accelerate barrier repair following a range of barrier insults (tape stripping, treatment with *N*-laurosarcosine or dodecylbenzene sulfonic acid), the mixture was not effective after barrier damage with SLS or ammoniumlaurylsulfosuccinate (162). These studies suggest that customized mixtures of the critical lipid species may be required to repair barrier damage resulting from differing insults. Further studies are required to relate the significance of these observations to human skin.

It is also becoming apparent that to optimize barrier integrity through the topical application of ceramides that the correct stereochemistry of these lipids is considered. X-ray diffraction studies have reported that chiral CER[NP] forms the characteristic short-periodicity phase (SPP) and LPP, while a racemic CER[NP] mix prevented formation of the LPP resulting in a disrupted lipid matrix (163).

### Enhanced Ceramide Synthesis Through Delivery of Ceramide Precursors

Given the critical importance of ceramides to the barrier function many researchers have sought routes to increase the synthesis of ceramides within the skin using lipid precursors. The earliest work relates to the correction of ceramide levels and barrier function in essential fatty acid deficiency by the application of linoleic and linolenic acid (164). Similarly, it has also been demonstrated that the low ratio of CER[EOS] linoleate to CER[EOS] oleate which is characteristically seen in skin in the winter months, and which may predispose such skin to winter xerosis, can be improved by up to 85%, through topical application of formulations containing linoleic acid in the form of natural oils (165). Brod et al. have also demonstrated similar effects on dry skin (166). Thus, increasing the proportion of CER[EOS] linoleate may improve SC function in such conditions.

Lactic acid, especially *L*-lactic acid, can also function as a general precursor to ceramides and this may explain the improvements in SC resilience observed following treatment with this  $\alpha$ -hydroxy acid. The *L*-chiral isomer improved SC barrier function, as measured by both reduction in TEWL values following a challenge with SLS, and by improved resistance to the appearance of dry skin in moisturization efficacy studies (167). These improvements were related to the overall increase in SC ceramide levels and especially ceramide 1 linoleate levels following use of the prototype formulation. Furthermore, *in vitro* studies with keratinocytes established that lactic acid was utilized for lipid biosynthesis and it is possible that this also takes place *in vivo* leading to increased ceramide levels and a more effective barrier.

Other precursors such as serine, the primary substrate for SPT are utilized by keratinocytes in the presence of thiols (lipoic acid and *N*-acetylcysteine) to stimulate ceramide biosynthesis (168). These thiols presumably activate SPT by thiol disulfide exchange mechanisms, and might be expected to provide benefit to the skin of subjects with a perturbed barrier.

Another option for enhancing ceramide biosyntheses is to use substrates, which can feed into the ceramide biosynthesis pathway beyond the rate-limiting enzyme. Carlomusto et al. have shown that the modified sphingoid base tetracyclphytosphingosine (TAPS) is a substrate for ceramide biosynthesis *in vitro* (169). *In vivo* topical application of TAPs lead to an increase in ceramide biosynthesis *in vivo* as measured by lipid analysis of tape-stripped SC and a corresponding increase in resistance to surfactant damage (170). In further studies, a synergistic improvement in SC ceramide levels and a corresponding increase in barrier function was achieved when TAPS was combined with  $\omega$ -hydroxy acids and linoleic acid. This triple lipid combination preferentially increased CER[EOS] level above other ceramides, supporting its proposed mode of action as a CER[EOS] precursor (170).

Activation of key enzymes is a promising route to increase lipid biosynthesis. Studies by Tanno and coworkers (171) have shown that nicotinamide can increase synthesis of ceramide and free fatty acid levels in the SC and decrease TEWL in dry skin. The mechanism of this action involves increased synthesis of acetyl CoA (as a general precursor for both lipid species) and of mRNA for SPT with an associated increases in enzyme activity.

PPAR are nuclear receptors that belong to the steroid/thyroid/retinoid receptor superfamily and are specifically involved in lipid homeostasis. Recent evidence suggests that

activation of these receptors by specific ligands can also increase the mRNA expression of several key enzymes involved in ceramide (SPT and  $\beta$ -glucocerebrosidase) and cholesterol (HMG CoA reductase) synthesis (172). It is of interest to note that expression of PPAR- $\alpha$  is down regulated in involved regions of psoriatic skin (173). Studies by Hara and coworkers have suggested that certain glycosphingolipids may also improve dry skin condition through activation of  $\beta$ -glucocerebrosidase (174). There is also an indication that, in vitro at least Vitamin C can influence the hydroxylation and synthesis of specific ceramides, notably CER[AP] and CER[AH] to improve the overall organization and water-retaining properties of these model systems (175). Whether vitamin C can influence the spectrum of ceramides synthesized in vivo remains to be established.

Novel routes to enhancing ceramide levels have appeared in recent literature; increased levels of ceramides are reported in the skin of elderly subjects following topical application of a preparation of *Streptococcus thermophilus* containing sphingomyelinase (176), and the potential of dietary manipulation leading to increased barrier function has been shown in mice following dietary supplementation of glucosylceramides obtained from rice bran and germ (177). Dietary supplementation with wheat germ extracts are also claimed to improve barrier function in humans.

### Influence of Ceramides on Keratinocyte Differentiation

Within this review we have been concerned primarily with the role of ceramide in barrier function. Extracellular or exogenously added ceramides may play an important pro-differentiation role, indirectly leading to improved SC resilience. For instance, exogenously supplied short-chain ceramides, and certain pseudoceramides are known to induce keratinocyte differentiation in vitro (32,157). Short-chain ceramides and pseudoceramides also potentiate the effects of Vitamin D, which is essential for keratinocyte differentiation (169). Furthermore, Vitamin D is known to activate keratinocyte sphingomyelinase, leading to increased intracellular levels of ceramide (178). The importance of vitamin D in regulating specific elements of lipid synthesis in the epidermis continues to emerge. It has been reported that gene silencing of the vitamin D receptor and certain coactivators leads to a decrease in glucosylceramide, but not cholesterol or fatty acid. There was a decreased transcription of ceramide glucosyltransferase and the fatty acid elongase (mentioned earlier in the chapter), both critical enzymes in the synthesis of glucosylceramides. Moreover, ABCA12 expression is also perturbed (179). Although the structure/function requirements for ceramide-induced keratinocyte differentiation remain to be elucidated, hydroxy acid containing ceramides have been shown to be superior to nonhydroxy acid containing ceramides in inducing keratinocyte differentiation. In addition, of four  $\omega$ -esterified fatty acid variants of CER[EOS] evaluated in vitro, CER[EOS] linoleate has been found to be the most potent differentiation enhancer (180). Similar effects have been reported for glycosylated forms of these molecules.

In contrast to their critical importance in barrier function, sphingolipids act as potent second messengers in diverse cellular signaling pathways (181–183). Ceramides are intimately involved, in cellular decisions on proliferation (184), differentiation (185), and apoptosis (186) and ultimately the ubiquitous roles fulfilled by ceramides impact skin condition at many different levels. Much of the initiation of mammalian apoptosis

and epidermal differentiation takes place at the mitochondrial level where the physicochemical properties and integrity of the membrane plays a critical role. Mitochondria are essentially sensors of sphingolipids and ceramides can influence membrane permeability effecting activation of the critical proteases (caspases) that can initiate apoptosis or differentiation (187). The mitochondrial membrane appears to represent a common destination where mediators of stress converge and where critical decisions about cellular adaptation or apoptosis are taken. It is becoming clear that ceramides directly or indirectly profoundly affect mitochondrial functions but it must be remembered that this is also necessary for epidermal differentiation (188,189). The most compelling evidence for a lack of these compounds on apoptosis comes from in vivo studies. In humans Jatoi et al. finds no effects of C2 and C6 ceramides on apoptosis (190). In the light of these studies and in vitro studies using realistic dose levels of short-chain ceramides can clearly induce epidermal differentiation by upregulating ABCA12 expression via the PPAR- $\delta$ -mediated signaling pathway which are both important for epidermal differentiation and lipogenesis (89) These studies are consistent with the earlier investigations reported by Pillai (32) and Paragh (33).

### CONCLUSIONS

Research into the structure and function of skin ceramides has increased dramatically over the past twenty five years. These complex lipids have been shown to influence many aspects of cutaneous biology, including the barrier, mechanical and desquamatory properties of the SC. In this respect our understanding of the relationship between SC lipids and cosmetic and pathological skin conditions has been pivotal in our continued desire and ability to improve these abnormal skin conditions, either through the use of defined barrier lipid species or their biosynthetic precursors. Nevertheless, as our techniques of investigation have become more sophisticated it has become increasingly evident that our understanding of these molecules remains in its infancy. The observations that the SC contain over 300 distinct ceramide species, derived from eleven classes suggests an exquisitely subtle relationship between ceramides and the maintenance of the essential function barrier with the correct physical and chemical characteristics. In addition there remains much to learn about the critical role that ceramides play deeper in the epidermis in influencing epidermal signaling and differentiation, and ultimately the factors that control their own biosynthesis.

### REFERENCES

1. Harding CR, Watkinson A, Rawlings AV, et al. Dry skin, moisturisation and corneodesmolysis. *Int J Cosmet Sci* 2000; 22:21–52.
2. Elias PM. Epidermal lipids, barrier function and desquamation. *J Invest Dermatol* 1983; 80(suppl):44–49.
3. Williams ML, Elias PM. The extracellular matrix of stratum corneum: role of lipids in normal and pathological function. *Crit Rev Ther Drug Carrier Syst* 1987; 3:95–122.
4. Schaefer H, Redelmeier TE. *Skin Barrier: Principles of Percutaneous Absorption*. Karger: Basel, 1996:310.
5. Wertz PW, van den Bergh B. The physical, chemical and functional properties of lipids in the skin and other biological barriers. *Chem Phys Lipids* 1998; 91:85–96.
6. Madison KC, Swartzendruber DC, Wertz PW, et al. Presence of intact intercellular lipid lamellae in the upper layers of the stratum corneum. *J Invest Dermatol* 1987; 88:714–718.

7. Epstein EH, Williams ML, Elias PM. Steroid sulphatase, X-linked ichthyosis and stratum corneum cohesion. *Arch Dermatol* 1981; 117:761–763.
8. Ransinghe AW, Wertz PW, Downing DT, et al. Lipid composition of cohesive and desquamated corneocytes from mouse ear skin. *J Invest Dermatol* 1986; 86:187–190.
9. Elias PM. Epidermal barrier function: intercellular lamellar lipid structures, origin, composition and metabolism. *J Control Release* 1991; 15:199–208.
10. Williams ML. Lipids in normal and pathological desquamation. In: Elias PM, ed. *Skin Lipids*. Volume 24. New York: Academic Press, 1991:211–262.
11. Mao-Qiang M, Feingold KR, Jain M, et al. Extracellular processing of phospholipids is required for permeability barrier homeostasis. *J Lipid Res* 1995; 36:1925–1935.
12. Rawlings AV. Skin waxes. Their composition, properties, structures and biological significance. In: Hamilton R, Christie W, eds. *Waxes*. Dundee: The Oily Press, 1995:223–256.
13. Han XL. Characterisation and direct quantitation of ceramide molecular species from lipid extracts of biological samples by electrospray ionisation tandem mass spectrometry. *Anal Biochem* 2002; 302:192–212.
14. Vietzke JP, Strassner M, Hintze U. Separation and identification of ceramides in the human stratum corneum by high-performance liquid chromatography coupled with electrospray ionisation mass spectrometry and electrospray multiple stage mass spectrometry profiling. *Chromatographia* 1999; 50: 15–20.
15. Vielhaber G, Pfeiffer S, Brade L, et al. Localisation of ceramides and glucosylceramides in human epidermis by immunogold electron microscopy. *J Invest Dermatol* 2001; 117:1126–1136.
16. Masukawa Y, Narita H, Sato H, et al. Comprehensive quantification of ceramide species in human stratum corneum. *J Lipid Res* 2009; 50:1708–1719.
17. Masukawa Y, Narita H, Shimizu E, et al. Characterization of overall ceramide species in human stratum corneum. *J Lipid Res* 2008; 49:1466–1476.
18. Wertz PW, Miethke MC, Long SA, et al. Composition of ceramides from human stratum corneum and comedones. *J Invest Dermatol* 1985; 84:410–412.
19. Robson KJ, Stewart ME, Michelsen S, et al. 6-hydroxy-4-sphinganine in human epidermal ceramides. *J Lipid Res* 1994; 35: 2060–2068.
20. Chopart M, Castiel I, Arbey E, et al. A new type of covalently bound ceramide in human epithelia. In: Marks R, Leveque JL, Voegeli R, eds. *The Essential Stratum Corneum*. London: M Dunitz, 2002:331–334.
21. Hamanaka S, Suzuki M, Suzuki A, et al. Epidermosides—structure and function of skin specific glycolipids. *Proc Japan Acad Ser B Phys Biol Sci* 2001; 77:51–56.
22. Uchida Y, Hara M, Nishio H, et al. Epidermal sphingomyelins are precursors for selected stratum corneum ceramides. *J Lipid Res* 2000; 41:2071–2082.
23. Hamanaka S, Hara M, Nishio H, et al. Human epidermal glucosylceramides are major precursors of stratum corneum ceramides. *J Invest Dermatol* 2002; 119:416–423.
24. Jennemann R, Sandhoff R, Langbein L, et al. Integrity of barrier function of the epidermis critically depends on glucosylceramide synthesis. *J Biol Chem* 2007; 282:3083–3094.
25. Motta S, Monti M, Sesana S, et al. Ceramide composition of the psoriatic scale. *Biochim Biophys Acta* 1993; 1182:147–151.
26. Wertz PW. Lipids and barrier function of the skin. *Acta Derm Venereol Suppl (Stockh)* 2000; 208(suppl):1–5.
27. Wertz PW, Madison KC, Downing DT. Covalently bound lipids of human stratum corneum. *J Invest Dermatol* 1989; 92:109–111.
28. Norlen L, Nicander I, Lundsjo A, et al. A new HPLC-based method for the quantitative analysis of inner stratum corneum lipids with special reference to the free fatty acid fraction. *Arch Dermatol Res* 1998; 290:508–516.
29. Vasireddy V, Uchida Y, Salem N Jr., et al. Loss of functional ELOV4 depletes very long chain fatty acids (>or=C28) and the unique omega-O-acylceramides in skin leading to neonatal death. *Hum Mol Genet* 2007; 16:471–482.
30. Li W, Sandhoff R, Kono M, et al. Depletion of ceramides with very long chain fatty acids causes defective skin permeability barrier function and neonatal lethality in ELOVL4 deficient mice. *Int J Biol Sci* 2007; 3:120–128.
31. Novotny J, Janusova B, Novotny M, et al. Short-chain ceramides decrease barrier properties. *Skin Pharmacol Physiol* 2009; 22:22–30.
32. Pillai K, Frew L, Cho S, et al. Synergy between the vitamin D precursor, 25 hydroxyvitamin D and short chain ceramides on human keratinocyte growth and differentiation. *J Investig Dermatol Symp Proc* 1996; 1(suppl):39–45.
33. Paragh G, Schling P, Ugocsai P, et al. Novel sphingolipid derivatives promote keratinocyte differentiation. *Exp Dermatol* 2008; 17:1004–1016.
34. Swartzendruber DC, Wertz PW, Madison KC, et al. Evidence that the corneocyte has a chemically bound lipid envelope. *J Invest Dermatol* 1987; 88:709–712.
35. Lazo ND, Meine JG, Downing DT. Lipids are covalently attached to rigid corneocyte protein envelopes existing predominately as  $\beta$ -sheets: a solid-state nuclear magnetic resonance study. *J Invest Dermatol* 1995; 105:296–300.
36. Nemes Z, Marekov LN, Fesus L, et al. A novel function for transglutaminase 1: attachment of long-chain omega-hydroxyceramides to involucrin by ester bond formation. *Proc Natl Acad Sci* 1999; 96:8402–8407.
37. Stewart ME, Downing DT. The omega-hydroxyceramides of pig epidermis are attached to corneocytes solely through omega-hydroxyl groups. *J Lipid Res* 2001; 42:1105–1110.
38. Meguro S, Arai Y, Masukawa Y, et al. Relationship between covalently bound ceramides and transepidermal water loss (TEWL). *Arch Dermatol Res* 2000; 292:463–468.
39. Behne M, Uchida Y, Seiki T, et al. Omega hydroxyceramides are required for corneocyte envelope formation and normal epidermal permeability barrier function. *J Invest Dermatol* 2000; 114:185–192.
40. Wertz PW, Downing DT. Ceramidase activity in porcine epidermis. *Biochim Biophys Acta* 1989; 1002:213–217.
41. Bowser PA, Nugteren D, White RJ, et al. Identification, isolation and characterisation of epidermal lipids containing linoleic acid. *Biochim Biophys Acta* 1985; 834:429–436.
42. Wertz PW, Downing DT. Free sphingosine in human epidermis. *J Invest Dermatol* 1990; 94:159–161.
43. Gupta AK, Fischer GJ, Elder JT, et al. Sphingosine inhibits phorbol ester-induced inflammation, ornithine decarboxylase activity and the action of protein kinase C in mouse skin. *J Invest Dermatol* 1988; 91:486–491.
44. Bibel DJ, Aly R, Shinefield HR. Antimicrobial activity of sphingosines. *J Invest Dermatol* 1992; 98:269–273.
45. Pavicic T, Wollenweber U, Farwick M, et al. Anti-microbial and –inflammatory activity and efficacy of phytosphingosine: an in vitro and in vivo study addressing acne vulgaris. *Int J Cosmet Sci* 2007; 29:181–190.
46. Small DM. The physical chemistry of lipids. In: Hanahan DJ, ed. *Handbook of Lipid Research*. Volume 4. New York: Plenum Press, 1986:672.
47. Singer SJ, Nicolson GL. The fluid mosaic model of the structure of cell membranes. *Science* 1972; 175:720–731.
48. Welti R, Glaser M. Lipid domains in model and biological membranes. *Chem Phys Lipids* 1994; 73:121–137.
49. Devaux PF, Zachowski A. Maintenance and consequences of membrane phospholipid asymmetry. *Chem Phys Lipids* 1994; 73:107–120.
50. Mouritsen OG, Jorgesen K. Dynamical order and disorder in lipid bilayers. *Chem Phys Lipids* 1994; 73:3–25.
51. McIntosh TJ, Stewart ME, Downing DT. X-ray diffraction of isolated skin lipids: reconstitution of intercellular lipid domains. *Biochemistry* 1996; 35:3649–3653.

52. White SH, Mirejovsky D, King GI. Structure of lamellar lipid domains and corneocyte envelopes of murine stratum corneum. an X-ray diffraction study. *Biochemistry* 1988; 27:3725–3732.
53. Bouwstra JA, Gooris GS, Weerheim A, et al. Characterization of stratum corneum structure in reconstructed epidermis by X-ray diffraction. *J Lipid Res* 1995; 36:496–504.
54. Bouwstra JA, Gooris GS, Salomons-de Vries MA, et al. Structure of human stratum corneum as a function of temperature and hydration: a wide-angle X-ray diffraction study. *Int J Pharm* 1992; 84:205–216.
55. Pilgram GSK, Van Pelt AM, Spies F, et al. Cryo-electron diffraction as a tool to study local variations in the lipid organization of human stratum corneum. *J Microscopy* 1998; 187:71–78.
56. Bouwstra JA, Gooris GS, Dubbelaar FRE, et al. Phase behaviour of stratum corneum lipids based on human ceramides: the role of natural and synthetic ceramide 1. *J Invest Dermatol* 2002; 118:606–617.
57. Moore DJ, Mendelsohn R. Adaptation to altered growth temperatures in *Acholeplasma laidlawii* b: fourier transform infrared studies of acyl chain conformational order in live cells. *Biochemistry* 1994; 33:4080–4085.
58. Moore DJ, Sills RH, Mendelsohn R. Conformational order of specific phospholipids in human erythrocytes: correlations with changes in cell shape. *Biochemistry* 1997; 36:660–664.
59. Mendelsohn R, Moore DJ. Vibrational spectroscopic studies of lipid domains in biomembranes and model systems. *Chem Phys Lipids* 1998; 96:141–157.
60. Moore DJ. Stratum corneum lipids and barrier function: biophysical studies of molecular organisation in sphingomyelin and ceramide [NS] bilayers. *Rec Res Dev Lipids* 2002; 6:55–63.
61. Chen H-C, Mendelsohn R, Rerek ME, et al. Effect of cholesterol miscibility and phase behavior in binary mixtures with synthetic ceramide 2 and octadecanoic acid. infrared studies. *Biochim Biophys Acta* 2001; 1512:345–356.
62. Rerek ME, Chen H-C, Markovic B, et al. Phytosphingosine and sphingosine ceramide headgroup hydrogen bonding: structural insights through thermotropic hydrogen/deuterium exchange. *J Phys Chem* 2001; 105:9355–9363.
63. Moore DJ, Mendelsohn R. IR determination of conformational order and phase behavior in ceramides and stratum corneum models. *Methods Enzymol* 2000; 312:228–247.
64. Ziboh VA, Miller CC, Cho YH. Metabolism of polyunsaturated fatty acids by skin epidermal enzymes: generation of anti-inflammatory and antiproliferative metabolites. *Am J Clin Nutr* 2000; (suppl 71):361S–366S.
65. Schreiner V, Gooris GS, Pfeiffer S, et al. Barrier characteristics of different human skin types investigated with X-ray diffraction, lipid analysis, and electron microscopy imaging. *J Invest Dermatol* 2000; 114:654–660.
66. Heinemann C, Paschold C, Fluhr J, et al. Induction of a hardening phenomenon by repeated application of SLS: analysis of lipid changes in the stratum corneum. *Acta Derm Venereol* 2005; 85:290–295.
67. Forslind B. A domain mosaic model of the skin barrier. *Acta Derm Venereol* 1994; 74:1–6.
68. Norlen L. Skin barrier structure and function: the single gel phase model. *J Invest Dermatol* 2001; 117:830–836.
69. Bouwstra JA, Dubbelaar FER, Gooris GS, et al. The lipid organization in the skin barrier. *Acta Derm Venereol Suppl (Stockh)* 2000; 208:23–30.
70. Pensack RD, Michniak BB, Moore DJ, et al. Infrared kinetic/structural studies of barrier reformation in intact stratum corneum following thermal perturbation. *Appl Spectrosc* 2006; 60:1399–1404.
71. Damien F, Boncheva M. The extent of orthorhombic lipid phases in the stratum corneum determines the barrier efficiency of human skin in vivo. *J Invest Dermatol* 2010; 130:611–614.
72. Abraham W, Downing DT. Interaction between corneocytes and stratum corneum lipid liposomes in vitro. *Biochim Biophys Acta* 1990; 1021:119–125.
73. Smith WP, Christensen MS, Nacht S, et al. Effects of lipids on the reaggregation and permeability of human stratum corneum. *J Invest Dermatol* 1982; 78:7–11.
74. Chapman SJ, Walsh A, Jackson S, et al. Lipids, proteins and corneocyte adhesion. *Arch Dermatol Res* 1991; 283:1679–1732.
75. Rawlings A, Hope J, Rogers J, et al. Skin dryness-what is it? *J Invest Dermatol* 1993; 100:510.
76. Sheu HM, Chao SC, Wong TW, et al. Human skin surface lipid film: an ultrastructural study and interaction with corneocytes and intercellular lipid lamellae of the stratum corneum. *Br J Dermatol* 1999; 140:385–391.
77. Pilgram GS, van der Meulen J, Gooris GS, et al. The influence of two azones and sebaceous lipids on the lateral organisation of lipids isolated from human stratum corneum. *Biochim Biophys Acta* 2001; 1511:244–254.
78. Menon GK, Ghadially R, Williams ML, et al. Lamellar bodies as delivery systems of hydrolytic enzymes: implications for normal and abnormal desquamation. *Br J Dermatol* 1992; 126:337–345.
79. Skerrow CJ, Cleland DG, Skerrow D. Changes to desmosome antigens and lectin binding sites during differentiation in normal epidermis: a quantitative ultrastructural study. *J Cell Sci* 1989; 92:667–677.
80. Egelrud T. Purification and preliminary characterisation of stratum corneum chymotryptic enzyme: a protease that may be involved in desquamation. *J Invest Dermatol* 1993; 101:200–204.
81. Houben E, Hachem JP, De Paepe K, et al. Epidermal ceramidase activity regulates epidermal desquamation via stratum corneum acidification. *Skin Pharmacol Physiol* 2008; 21:111–118.
82. Watkinson A, Lee RS, Moore AE, et al. Reduced barrier efficiency in axillary stratum corneum. *Int J Cosmet Sci* 2002; 24:151–161.
83. Lavrijsen APM, Bouwstra JA, Gooris GS, et al. Reduced skin barrier function parallels abnormal stratum corneum lipid organization in patients with lamellar ichthyosis. *J Invest Dermatol* 1995; 105:619–624.
84. Menon G, Ghadially R. Morphology of lipid alterations in the epidermis: a review. *Microsc Res Tech* 1997; 37:180–192.
85. Pilgram GSK, Vissiers DCJ, van der Meulen H, et al. Aberrant lipid organization in stratum corneum of patients with atopic dermatitis and lamellar ichthyosis. *J Invest Dermatol* 2001; 117:710–717.
86. Kyung-Koch Hong, Hee-Ryung Cho, Won-Chui Ju, et al. A study of altered expression of serine palmitoyltransferase and ceramidase in psoriatic skin lesion. *J Korean Med Sci* 2007; 22:862–867.
87. Kelsell DP, Norgett EE, Unsworth H, et al. Mutations in ABCA12 underlie the severe congenital skin disease Harlequin Ichthyosis. *Am J Hum Genet* 2005; 76:794–803.
88. Zuo Y, Zhuang DZ, Han R, et al. ABCA12 maintains the epidermal lipid permeability barrier by facilitating formation of ceramide linoleic esters. *J Biol Chem* 2008; 283:36624–36635.
89. Jiang YJ, Uchida Y, Lu B, et al. Ceramide stimulates ABCA expression via peroxisome proliferator activated receptor (delta) in human keratinocytes. *J Biol Chem* 2009; 284:18942–18952.
90. Paige DG, Morse-Fisher N, Harper JI. Quantification of stratum corneum ceramides and lipid envelope ceramides in the hereditary ichthyoses. *Br J Dermatol* 1994; 131:23–27.
91. Imokawa G, Abe A, Jin K, et al. Decreased levels of ceramides in stratum corneum of atopic dermatitis: an etiological factor in atopic dermatitis. *J Invest Dermatol* 1991; 96:523–526.
92. Matsumoto M, Umemoto N, Sugiuta H, et al. differences in ceramide composition between “dry” and “normal” skin in patients with atopic dermatitis. *Arch Dermatol Res* 1999; 79:246–247.
93. Yamamoto A, Serizawa S, Ito M, et al. Stratum corneum lipid abnormalities in atopic dermatitis. *Arch Dermatol Res* 1991; 283:219–223.
94. Bleck O, Beck D, Ring J, et al. Two ceramide subfractions detectable in CER[AS] position by HPTLC in skin surface lipids of non-lesional skin of atopic eczema. *J Invest Dermatol* 1999; 113:384–900.
95. Macheleidt O, Kaiser HW, Sandhoff K. Deficiency of epidermal protein bound omega-hydroxyceramides in atopic dermatitis. *J Invest Dermatol* 2002; 119:166–173.



96. Cui CY, Kusada S, Seguchi T, et al. Decreased levels of prosaposin in atopic skin. *J Invest Dermatol* 1997; 109:319–323.
97. Jensen JM, Folster-Holst R, Baranowsky A, et al. Impaired sphingomyelinase activity and altered differentiation in atopic dermatitis. *J Invest Dermatol* 2004; 122:1423–1431.
98. Murata Y, Ogata J, Higaki Y, et al. Abnormal expression of sphingomyelin acylase in atopic dermatitis: an etiological factor for ceramide deficiency? *J Invest Dermatol* 1996; 106:1242–1249.
99. Hara J, Higuchi K, Okamoto R, et al. High-expression of sphingomyelin deacylase is an important determinant of ceramide deficiency leading to barrier disruption in atopic dermatitis. *J Invest Dermatol* 2000; 115:406–413.
100. Kusuda S, Cui CY, Takahashi M, et al. Localisation of sphingomyelinase in lesional skin of atopic dermatitis patients. *J Invest Dermatol* 1998; 111:733–778.
101. Imokawa G. A possible mechanism underlying the ceramide deficiency in atopic dermatitis: expression of a deacylase enzyme that cleaves the N-acyl linkage of sphingomyelin and glucosylceramide. *J Dermatol Sci* 2009; 55:1–9.
102. Wakita H, Matsushita K, Nishimura K, et al. Sphingosylphosphorylcholine stimulates proliferation and upregulates cell-surface-associated plasminogen activator activity in cultured human keratinocytes. *J Invest Dermatol* 1998; 110:253–258.
103. Arikawa J, Ishibashi M, Kawashima M, et al. Decreased levels of sphingosine, a natural antimicrobial agent, may be associated with vulnerability of the stratum corneum from patients with atopic dermatitis to colonisation by *Staphylococcus aureus*. *J Invest Dermatol* 2002; 119:433–439.
104. Downing DT, Stewart ME, Wertz PW, et al. Essential fatty acids and acne. *J Am Acad Dermatol* 1986; 14:221–225.
105. Yamamoto A, Takenouchi K, Ito M. Impaired water barrier function in acne vulgaris. *Arch Dermatol Res* 1995; 287:214–218.
106. Harding CR, Moore AE, Rogers JS, et al. Dandruff: a condition characterised by decreased levels of intercellular lipids in scalp stratum corneum and impaired barrier function. *Arch Dermatol Res* 2002; 294:221–230.
107. Warner RR, Schwartz JR, Boissy Y, et al. Dandruff has an altered stratum corneum ultrastructure that is improved with zinc pyrithione shampoo. *J Am Acad Dermatol* 2001; 45:897–903.
108. Rogers JS, Moore AE, Meldrum H, et al. Increased scalp skin lipids in response to anti-dandruff treatment containing zinc pyrithione. *Arch Dermatol Res* 2003; 295:127–129.
109. Denda M, Koyama J, Hori J, et al. Age- and sex-dependant changes in stratum corneum sphingolipids. *Arch Dermatol Res* 1993; 285:415–417.
110. Saint-Leger D, Francois AM, Leveque JL, et al. Stratum corneum lipids in skin xerosis. *Dermatologica* 1989; 178:151–155.
111. Rogers JS, Harding CR, Mayo A, et al. Stratum corneum lipids: the effect of ageing and the seasons. *Arch Dermatol Res* 1996; 288:765–770.
112. Oldroyd J, Critchley P, Tiddy G, et al. Specialised role for ceramide one in the stratum corneum water barrier. *J Invest Dermatol* 1994; 102:525.
113. Saint-Leger D, Francois AM, Leveque JL, et al. Age associated changes in stratum corneum lipids and their relation to dryness. *Dermatologica* 1988; 177:159–164.
114. Chopart M, Castiel-Higounen I, Arbey E, et al. Quantitative and qualitative analysis of ceramides in the stratum corneum of normal & dry skin. In: Marks R, Leveque JL, Voegeli R, eds. *The Essential Stratum Corneum*. London: M Dunitz, 2002.
115. Sugino K, Imokawa G, Maibach HI. Ethnic differences of varied stratum corneum function in relation to stratum corneum lipids. *J Invest Dermatol* 1993; 102:482.
116. Rawlings AV. Ethnic skin types are there differences in skin structure and function. *Int J Cosmet Sci* 2006; 28:79–83.
117. Ghadially R, Brown B, Sequiera-Martin SM, et al. The aged epidermal permeability barrier: structural, functional, and lipid biochemical abnormalities in humans and a senescent murine model. *J Clin Invest* 1995; 95:2281–2290.
118. Akimoto K, Yoshikawa N, Higaki Y, et al. Quantitative analysis of stratum corneum lipids in xerosis and asteatitic eczema. *J Dermatol* 1993; 20:1–6.
119. Jensen JM, Forl M, Winoto-Morbach S, et al. Acid and neutral sphingomyelinase, ceramide synthase and acid ceramidase activities in cutaneous ageing. *Exp Dermatol* 2005; 14:609–618.
120. Norlen L, Nicander I, Roxell BL, et al. Inter- and intra-individual differences in human skin stratum corneum lipid content related to physical parameters of skin barrier function in vivo. *J Invest Dermatol* 1999; 112:72–77.
121. Lampe MA, Burlingame AL, Whitney J, et al. Human stratum corneum lipids: characterisation and regional variations. *J Lipid Res* 1983; 24:120–130.
122. Imokawa G, Akasaki S, Minematsu Y, et al. Importance of intercellular lipids in water retention properties of the stratum corneum: induction and recovery study of surfactant dry skin. *Arch Dermatol Res* 1989; 281:45–51.
123. Imokawa G, Akasaki S, Minematsu Y, et al. Selective recovery of deranged water-holding properties by stratum corneum lipids. *J Invest Dermatol* 1986; 87:758–761.
124. Fulmer AW, Kramer GJ. Stratum corneum abnormalities in surfactant induced dry scaly skin. *J Invest Dermatol* 1986; 80:598–602.
125. Denda M, Koyama R, Horii I, et al. Sphingolipids & free amino acids in experimentally induced scaly skin. *Arch Dermatol Res* 1992; 284:363–367.
126. Rawlings A, Hope J, Rogers J, et al. Abnormalities in stratum corneum structure, lipid composition and desmosomal degradation in soap-induced winter xerosis. *J Soc Cosmet Chem* 1994; 45:203–220.
127. Nappe C, Delesalle G, Jansen A, et al. Decrease in ceramide II in skin xerosis. *J Invest Dermatol* 1993; 100:530.
128. Nieminen E, Leikola E, Kolijonen M, et al. Quantitative analysis of epidermal lipids by thin layer chromatography with special reference to seasonal variation. *Acta Derm Venereol* 1967; 47:327–338.
129. Agner T, Serup J. Seasonal variation of skin resistance to irritants. *Br J Dermatol* 1989; 121:323–328.
130. Nardo A, Sugino K, Wertz P, et al. Sodium lauryl sulphate induced irritant contact dermatitis: a correlation study between ceramides and in vivo parameters of irritation. *Contact Dermatitis* 1996; 35:86–91.
131. Takagi Y, Nakagawa H, Yaginuma T, et al. An accumulation of glucosylceramide in the stratum corneum due to attenuated activity of beta-glucocerebrosidase is associated with the early phase of UVB-induced alteration in cutaneous barrier function. *Arch Dermatol Res* 2005; 297:18–25.
132. Takagi Y, Nakagawa H, Kondo H, et al. Decreased levels of covalently bound ceramide are associated with ultraviolet B-induced perturbation of the skin barrier. *J Invest Dermatol* 2004; 123:1102–1109.
133. Denda N, Sato J, Tsuchiya T, et al. Low humidity amplifies the hyperproliferative to barrier disruption: implications for seasonal exacerbations of inflammatory dermatoses. *J Invest Dermatol* 1998; 111:873–878.
134. Ashida Y, Denda M, Hirao T. Histamine H1 and H2 receptor antagonists accelerate skin barrier repair and prevent epidermal hyperplasia induced by barrier disruption in a dry environment. *J Invest Dermatol* 2001; 116:261–265.
135. Denda M. New strategies to improve skin barrier homeostasis. *Adv Drug Deliv Rev* 2002; 54:S123–S130.
136. Feingold KR. Permeability barrier homeostasis; its biochemical basis and regulation. *Cosmet Toil* 1997; 112:49–59.
137. Grubauer G, Elias PM, Feingold KR. Transepidermal water loss: the signal for recovery of barrier structure and function. *J Lipid Res* 1989; 30:323–333.
138. Welzel J, Wilhelm KP, Wolff HH. Skin permeability barrier and occlusion: no delay of repair in irritated human skin. *Contact Dermatitis* 1996; 35:163–168.

139. Holleran WM, Man MQ, Wen NG, et al. Sphingolipids are required for mammalian epidermal barrier function-inhibition of sphingolipid synthesis delays barrier recovery after acute perturbation. *J Clin Invest* 1991; 88:1338-1345.
140. Stachowitz S, Alessandrini F, Abeck D, et al. Permeability barrier disruption increases the level of serine palmitoyltransferase in human epidermis. *J Invest Dermatol* 2002; 119:1048-1052.
141. Harris IR, Farrell AM, Holleran WM, et al. Parallel regulation of sterol regulatory element binding protein-2 and the enzymes of cholesterol and fatty acid synthesis but not ceramide synthesis in cultured human keratinocytes and murine epidermis. *J Lipid Res* 1998; 39:412-422.
142. Holleran WM, Takagi Y, Menon G, et al. Permeability barrier requirements regulate epidermal B-glucocerebrosidase. *J Lipid Res* 1994; 35:905-912.
143. Doering T, Holleran WM, Potratz A, et al. Sphingolipid activator proteins are required for epidermal permeability barrier formation. *J Biol Chem* 1999; 274:11038-11045.
144. Alessandrini F, Stachowitz S, Ring J, et al. The level of prosaposin is decreased in the skin of patients with psoriasis vulgaris. *J Invest Dermatol* 2001; 116:394-400.
145. Menon GK, Price LF, Bommannan B, et al. Selective obliteration of the epidermal calcium gradient leads to enhanced lamellar body secretion. *J Invest Dermatol* 1994; 102:789-795.
146. Elias PM, Ahn SK, Denda M, et al. Modulations in epidermal calcium regulate the expression of differentiation-specific markers. *J Invest Dermatol* 2002; 119:1128-1136.
147. Denda M, Katagiri C, Maruyama N. Some magnesium salts and a mixture of magnesium and calcium salts accelerate skin barrier recovery. *Arch Dermatol Res* 1999; 291:560-563.
148. Denda M, Inoue K, Inomata S, et al.  $\gamma$ -Aminobutyric acid (A) receptor antagonists accelerate cutaneous barrier recovery and prevent epidermal hyperplasia induced by barrier disruption. *J Invest Dermatol* 2002; 119:1041-1047.
149. Denda M, Inoue K, Fuziwaru S, et al. P2X purinergic receptor antagonist accelerates skin barrier repair and prevents epidermal hyperplasia induced by skin barrier disruption. *J Invest Dermatol* 2002; 119:1034-1040.
150. Wood LC, Jackson SM, Elias PM, et al. Cutaneous barrier perturbation stimulates cytokine production in the epidermis of mice. *J Clin Invest* 1992; 90:482-487.
151. Nickoloff BJ, Naidu Y. Perturbation of epidermal barrier function correlates with initiation of cytokine cascade in human skin. *J Am Acad Dermatol* 1994; 30:535-546.
152. Williams ML, Elias PM, Feingold KR. Regulation and differentiation in newborn human keratinocytes by endogenous ligands of nuclear hormone receptors. *J Skin Barr Res* 2000; 2:3-26.
153. Beradesca E, Vignoli GP, Oresago C, et al. Prevention of barrier function damage by topically applied ceramides. Proceed 17th IFSCC, International Federation Society Cosmetic Chemists, Int Congress 1992; 1:881-889.
154. Linter K, Mondon P, Girard F, et al. The effect of a synthetic ceramide 2 on transepidermal water loss after stripping or SLS treatment: an in vivo study. *Int J Cosmet Chem* 1997; 19:15-25.
155. Chamlin SL, Kao J, Frieden IJ, et al. Ceramide dominant barrier repair lipids alleviate childhood atopic dermatitis. Changes in barrier function provide a sensitive indicator of disease activity. *J Am Acad Dermatol* 2002; 47:198-208.
156. Imokawa G. Ceramides as natural moisturizing factors and their efficacy in dry skin. In: Leyden JJ, Rawlings AV, eds. *Skin Moisturisation. Cosmetic Science and Technology Series. Volume 25.* New York: Marcel Dekker, Inc., 2002:267-302.
157. Uchida Y, Holleran WM, Elias PM. On the effects of topical synthetic pseudoceramides: comparison of possible keratinocytes toxicities provoked by the pseudoceramides, PC104 and BIO391, and natural ceramides. *J Dermatol Sci* 2008; 51:37-43.
158. Kwon YB, Kim, CD, Youm J-K. Novel synthetic ceramide derivatives increase intracellular calcium levels and promote epidermal keratinocytes differentiation. *J Lipid Res* 2007; 48:1936-1943.
159. De Paepe K, Roseeuw D, Rogiers V. Repair of acetone- and sodium lauryl sulphate-damaged human skin barrier function using topically applied emulsions containing barrier lipids. *J Eur Acad Derm Venereol* 2002; 16:587-594.
160. Mao-Qiuang M, Feingold KR, Elias PM. Exogenous lipids influence permeability barrier recovery in acetone-treated murine skin. *Arch Dermatol* 1993; 129:728-738.
161. Zettersten EM, Ghadially R, Feingold KR, et al. Optimal ratios of topical stratum corneum lipids improve barrier recovery in chronologically aged skin. *J Am Acad Dermatol* 1997; 37:403-408.
162. Yang L, Mao-Qiang M, Talbeni M, et al. Topical stratum corneum lipids accelerate barrier repair after tape-stripping, solvent treatment and some but not all types of detergent treatment. *Br J Dermatol* 1995; 133:679-685.
163. Wollenweber U, Korevaar K, Rawlings AV, et al. Application of a skin identical lipid concentrate for enhanced skin moisturisation and protection. *SOFA* 2004; 130.
164. Prottey C, Hartop PJ, Press M. Correction of the cutaneous manifestations of essential fatty acid deficiency in man by application of sunflower seed oil to the skin. *J Invest Dermatol* 1975; 64:228-234.
165. Conti A, Rogers J, Verdejo P, et al. Seasonal influences on stratum corneum ceramide 1 fatty acids and the influence of topical essential fatty acids. *Int J Cosmet Sci* 1996; 18:1-12.
166. Brod J, Traitler H, Studer A, et al. Evolution of lipid composition in skin treated with blackcurrant seed oil. *Int J Cosmet Sci* 1988; 10:149-159.
167. Rawlings AV, Conti A, Verdejo P, et al. The effect of lactic acid isomers on epidermal lipid biosynthesis and stratum corneum barrier function. *Arch Dermatol Res* 1996; 288:383-390.
168. Zhang K, Kosturko R, Rawlings AV. The effect of thiols on epidermal lipid biosynthesis. *J Invest Dermatol* 1995; 104:687.
169. Carlomusto M, Pillai K, Rawlings AV. Human keratinocytes in vitro can utilise exogenously supplied sphingolipid analogues for keratinocyte ceramide biosynthesis. *J Invest Dermatol* 1996; 106:919.
170. Davies A, Verdejo P, Feinberg C, et al. Increased stratum corneum ceramide levels and improved barrier function following treatment with tetraacetylphytosphingosine. *J Invest Dermatol* 1996; 106:918.
171. Tanno O, Ota Y, Kitamura N, et al. Nicotinamide increases the biosynthesis of ceramides as well as other stratum corneum lipids to improve the epidermal permeability barrier. *Br J Dermatol* 2000; 143:524-531.
172. Rivier M, Castiel I, Safonova I, et al. Peroxisome Proliferator-activated receptor- $\alpha$  enhances lipid metabolism in a skin equivalent model. *J Invest Dermatol* 2000; 114:681-687.
173. Rivier M, Safonova I, Lebrun P, et al. Differential expression of Peroxisome Proliferator-activated receptor subtypes during the course of epidermal differentiation. *J Invest Dermatol* 1998; 111:1116-1121.
174. Hara M, Uchida Y, Haratake A, et al. Galactocerebrosidase and not glucocerebrosidase or ceramide stimulate epidermal beta-glucocerebrosidase activity. *J Dermatol Sci* 1998; 16:111-119.
175. Ponc M, Weerheim A, Kempenaar J, et al. The formation of competent barrier lipids in reconstructed human epidermis requires the presence of Vitamin C. *J Invest Dermatol* 1997; 109:348-355.
176. Di Marzio L, Cinque B, Cupelli F, et al. Increases of skin-ceramide levels in aged subjects following a short-term topical application of bacterial sphingomyelinase from *Streptococcus thermophilus*. *Int J Immunopath Pharmacol* 2008; 21:137-143.
177. Tsuji K, Mitsutake S, Ishikawa J, et al. Dietary glucosylceramides improves skin barrier function in hairless mice. *J Dermatol Sci* 2006; 44:101-107.
178. Carlomusto M, Mahajan M, Pillai S. Vitamin D-mediated keratinocyte differentiation does not involve sphingomyelin hydrolysis. *J Invest Dermatol* 1997; 108:660.
179. Oda Y, Uchida Y, Moradian S, et al. Vitamin D receptor and coactivators SRC2 and 3 regulate epidermal specific sphingolipid

- production and permeability barrier formation. *J Invest Dermatol* 2009; 129:1367–1378.
180. Bosko C, Samares S, Santanastasio H, et al. Influence of fatty acid composition of acylceramides on keratinocyte differentiation. *J Invest Dermatol* 1996; 106:871.
181. Spiegel S, Merrill AH. Sphingolipid metabolism and cell growth regulation. *FASEB J* 1996; 10:1388–1397.
182. Hunnan YA. Functions of ceramides in coordinating cellular responses to stress. *Science* 1996; 274:1855–1859.
183. Merrill AH, Schmelz E-M, Dillehay DL, et al. Sphingolipids—the enigmatic lipid class: biochemistry, physiology and pathophysiology. *Toxic Appl Pharmacol* 1997; 142:208–225.
184. Jung EM, Griner RD, Mann-Blakeney R, et al. A potential role for ceramide in the regulation of mouse epidermal keratinocyte proliferation and differentiation. *J Invest Dermatol* 1998; 110:318–323.
185. Wakita H, Tokura Y, Yagi H, et al. Keratinocyte differentiation is induced by cell permeant ceramides and its proliferation is promoted by sphingosine. *Arch Dermatol Res* 1994; 286:350–354.
186. Allan D, Shawyer A, Taylor A. Mechanisms by which short chain ceramides cause apoptosis. *Biochim Soc Trans* 1999; 27:428–432.
187. Tomasini B, Testi R. Mitochondria as sensors of sphingolipids. *Biochimie* 2002; 84:123–129.
188. Siskind LJ, Kolesnick RN, Colombini M. Ceramide channels increase the permeability of the mitochondrial outer membrane to small proteins. *J Biol Chem* 2002; 277:26796–26803.
189. Wieder T, Orfanos CE, Geilen CC. Induction of ceramide-mediated apoptosis by the anticancer phospholipid analog, hexadecylphosphocholine. *J Biol Chem* 1998; 273:11025–11031.
190. Jatoi A, Suman VY, Schaefer P, et al. A phase II clinical study of topical ceramide for cutaneous breast cancer. *Breast Cancer Res Treat* 2003; 80:99–104.

# Perfumes

Jeanne Duus Johansen

## DEFINITIONS

A fragrance ingredient is any basic substance used for its odorous, odor-enhancing, or blending properties in the composition of perfumes. A perfume is a blend of fragrance ingredients diluted in ethanol and experienced over a certain time frame. It is also named the fragrance formula and may consist of 10 to several hundred ingredients. A fragrance ingredient may be either a chemical or a natural product (1).

Natural fragrance ingredients are produced from natural products such as plant parts, for example, petals, leaves, bark, roots, or fruits from certain plant families (1). Animal secretions such as musk from the male musk deer have been used for their odoriferous properties, but are now replaced by blends of chemicals for the reason of animal welfare protection. The fragrance ingredients are extracted from the plants by processes such as distillation, extraction, or expression.

The resulting natural products are often complex mixtures consisting of numerous ingredients. In some cases, the characteristic odor is due to a particular ingredient and the isolation of these odor determinants is the original basis of production of chemical ingredients. Fragrance chemicals may be isolated from the natural products or synthesized from basic organic chemicals. The synthesized chemicals may be nature-identical; that is, imitations of naturally occurring substances or entirely new chemicals never identified in nature. Most fragrance ingredients are natural or nature-identical (1). About 2,500 fragrance ingredients are in current use for compounding perfumes.

## APPLICATIONS OF PERFUMES

Perfumes are added to many types of consumer products such as cosmetics, detergents, air fresheners, sanitary napkins, and toys. Perfumes are also used in aromatherapy and herbal remedies as well as industrial settings. Perfumes are products in themselves sold as parfum, eau de toilette, and eau de cologne. A perfume is developed for one particular type of product, and the composition may have to be changed to retain the same odor, if it is incorporated into a different type of product.

Perfumes may be used to mask unpleasant odors from the basic ingredients, for example, in skin care products. In case a perfume is added for this purpose only, it is termed a masking perfume and is usually of a simple composition, consisting of few ingredients. Certain fragrance ingredients such as farnesol and geraniol have antibacterial properties and may be used as preservatives.

Plant extracts are by some regarded as functional ingredients, claimed to act as, for example, anti-irritants. The same ingredients may in other cases be used just to provide a pleasant odor.

Perfumes are part of the daily life in modern society as it was in ancient times. The most intense skin exposure comes

from cosmetic products, especially stay-on cosmetics, which is also the cause of most contact allergic reactions.

## ADVERSE REACTIONS TO FRAGRANCE INGREDIENTS

A few fragrance ingredients are banned by industry because of their neurotoxicity or carcinogenic properties ([www.ifa.org](http://www.ifa.org)), but the majority of fragrance ingredients have not been evaluated at all for systemic effects or poorly so. Effects on the respiratory organs from inhalation of perfumes have been described, mediated by sensory or irritant mechanisms (2). Skin reactions as contact urticaria, photoallergy, and phototoxicity are well recognized but infrequent skin side effects. Psoralens in naturally occurring fragrance ingredients were previously the cause of phototoxic reactions giving rise to acute erythema and followed by long-standing hyperpigmentation. The content of the light sensitivity-inducing substances is now regulated and the problem has diminished. In the 1970s, the fragrance ingredient musk ambrette was the cause of an epidemic of photoallergy, particularly in men following the use of after-shave. The usage of musk ambrette was reduced and in 1995 the substance was prohibited from use in cosmetics in Europe (<http://ec.europa.eu/enterprise/cosmetics/cosing>).

Immediate contact reaction to fragrance ingredients is often of the nonimmunological type (3). This means that most individuals will react with local erythema and edema if exposed to the substance in a sufficient concentration. The fragrance ingredient cinnamal is capable of producing nonimmunological contact urticarial reactions, so is Balsam of Peru and cinnamic acid (3). Allergic contact dermatitis is the most frequently reported adverse reaction in relation to fragrance ingredients (4).

## ALLERGIC CONTACT DERMATITIS

Fragrance ingredients are low molecular weight substances, which easily penetrate intact skin. About 100 of the 2,500 ingredients used for compounding perfumes have been described as capable of inducing contact allergy in humans (5). Fragrance ingredients are the most common cause of allergic contact dermatitis because of cosmetics, being responsible for 25% to 45% of the allergic reactions depending on the population under study, closely followed by the preservatives. Allergic contact dermatitis due to fragrance ingredients may involve the face, hands, the axilla, or be generalized depending on the causative products (4).

Contact allergy to fragrance ingredients is diagnosed in 10% of eczema patients in Europe and North America (4). Estimates show that in terms of population frequencies, it can be translated into 1.7% to 4.2% of the general population with either a high or low degree of sensitivity to fragrance ingredients. In Germany, this corresponds to 1.4 to 3.4 million people (6).

In Denmark, the frequency of contact allergy to the fragrance ingredients in a sample of women aged 18 to 41 years recruited from the general population rose from 0.7% in 1990 to 3.9% in 1998 and decreased again to 2.3% in 2006 (7). A statistical significant relationship between fragrance allergy, cosmetic dermatitis within the past 12 months, and seeing a doctor for this condition was established in the population (7).

While contact allergy in children to cosmetic ingredients previously was rare, allergy to fragrance ingredients is seen in about 2% of children 12 to 16 years of age with almost equal frequency in boys and girls (8). No investigation in the general population has yet included the new marker of fragrance allergy, fragrance mix II (see later in the chapter), which may add to the prevalence of fragrance allergy.

### CAUSATIVE INGREDIENTS AND DIAGNOSIS

Since the beginning of the 1980s, a mixture of eight fragrance ingredients, named the fragrance mix I, has been used for screening purposes in the routine investigation of allergic contact dermatitis (Table 19.1). The mixture has been valuable in diagnosing fragrance contact allergy, and only few modifications have been made to its original composition over the years. In 1984 the initial patch test concentration of 16% was reduced to 8% because of many irritant reactions, which seemed to be caused mainly by the presence of cinnamal. As many fragrance ingredients are used in composing perfumes, investigations have been conducted to identify significant fragrance ingredients not present in the fragrance mix I (9,10,12,13). From this knowledge base a new test has been designed, the fragrance mix II, which contains six fragrance chemicals (14–16) (Table 19.1), compiled to a test concentration of 14% in pet. This has also been included in the European baseline series together with its main ingredient hydroxyisohexyl 3-cyclohexenecarboxaldehyde (Lyrall<sup>®</sup>) (17). In a recent investigation from Belgium, the fragrance mix I gave positive reactions in 9.0%; the fragrance mix II and hydroxyisohexyl 3-cyclohexenecarboxaldehyde in 2.1% of patch tested eczema patients (18). Contact allergy to hydroxyisohexyl 3-cyclohexenecarboxaldehyde is much less frequent in North America (19), where a positive reaction to the substance in 0.4% of consecutively patch tested patients were seen, than in Europe. The reason could be that hydroxyisohexyl 3-cyclohexene

carboxaldehyde is not used to the same extent in underarm preparations in North America as in Europe. Deodorants/antiperspirants are product types carrying a high risk of sensitization to fragrance ingredients (20,21).

The ingredients of the fragrance mix I and II are present in most consumer products in combinations and not infrequently in concentrations that is capable of eliciting allergic contact dermatitis (4,22). This explains the value of the two fragrance mixes as diagnostic tools and links the patch test reactions to exposure and clinical disease. A natural *Myroxylon pereirae* is also part of the European baseline series and is used in some countries in topical medicaments and also in the form of extracts and distillates in fragrances (23). Work has been done to optimize the identification of contact allergy caused by natural extracts (9,10) (Table 19.1). Some natural extracts have a simple composition, consisting of only a few chemicals, an example is clove oil that contains up to 80% geraniol, a well-known allergen. Others have a very complex composition, and even though they are well recognized as causes of allergic reactions, the allergens in the extracts are not known. An example is *Evernia prunastri* (oakmoss absolute). As *E. prunastri* is a major cause of allergic reactions, investigations have been undertaken to pinpoint the major allergens. A bioguided fractionation procedure was performed in allergic individuals with fractions of the extracts until the responsible allergens, chloroatranol and atranol, were identified (24). This opens up the possibility of producing extracts of *E. prunastri* with no or low levels of these two strong allergens.

Some natural products from the terpene family, such as limonene and linalool, will form allergens, when oxidized, while they in their unoxidized state have only weak allergenic properties or none. The allergens formed are mainly hydroperoxides with strong allergenic potential (25) Antioxidants can prevent oxidation for some time, but when the antioxidant is consumed, the oxidation starts immediately.

### COSMETIC PRODUCTS AND ALLERGIC CONTACT DERMATITIS TO FRAGRANCE INGREDIENTS

Investigations of fragrance allergic individuals have shown that initiation of disease typically is caused by a fragranced deodorant, a cologne/perfume, or both (20). High levels of well-known allergens have been shown particularly in fine fragrances. A parfum may contain up to 30% of fragrance ingredients, while 1% is typical for deodorants. This means that the individual ingredients are present in much higher concentrations in perfumes than in other products. The same allergens have been found also in significant concentrations in naturally based perfumes, deodorants, and toy perfumes (4).

The risk of sensitization will primarily depend on exposure concentration. The exposures as well as the sensitivity of the individual are decisive factors of whether eczema develops in a sensitized individual. A key determinant in exposure is the concentration of allergen per unit skin surface. However, also the formulation of a product influences the risk of elicitation of allergy; for example, from experiments it seems that deodorant sprays are more likely to give reactions given the same conditions and contents of allergens as deodorant sticks. Other factors that affect the risk of elicitation in man are the number of allergens in a product, the frequency of exposure, the region of application, and the skin condition (4). The intensity of skin contact is important, which means that stay-on products generally give a higher risk of sensitization and elicitation than wash-off products given the same concentrations of allergens.

**Table 19.1** Natural Extracts Frequently Reported as Causing Positive Patch Tests in Eczema Patients

Ingredient
Cedarwood oil
Clove bud oil
Dwarf pine needle oil
Eucalyptus oil
<i>Evernia furfuracea</i> (treemoss abs)
<i>Evernia prunastri</i> (oakmoss abs)
Geranium oil bourbon
Jasmine abs
Lavender oil
Lemongrass oil
<i>Myroxylon pereirae</i> (Balsam of Peru)
Narcissus abs
Patchouli oil
Peppermint oil
Sandalwood oil
Spearmint oil
Ylang-ylang oil I
Ylang-ylang oil II

Source: From Refs. 9 to 11.

### THE FRAGRANCE ALLERGIC PATIENT

There is a considerable interindividual variation in the sensitivity of fragrance allergic individuals. Some cannot tolerate any fragrance products at all; others may be able to use some type of products such as shampoos without problems because of the short time of contact and the dilution factor or even some stay-on products. The products most difficult to tolerate on the skin are perfumed deodorants, perfumes/colognes, and skin care products. In a questionnaire study of the strategies of fragrance allergic eczema patients in their choice of cosmetic products, 45.3% answered that they had found some scented products that they could tolerate, 31.6% had not tried to find any scented products, and 22% had tried but could not find any (26). The methods most often used were trying different products and reading the ingredient label. Patients were also asked if they felt fragrance allergy had an impact on their life. 17.1% of respondents reported sick leave because of fragrance allergy, and 45.3% found that fragrance allergy significantly affected their daily living (26).

Indicative of the clinical problems the fragrance allergic individual may have is their level of sensitivity at patch testing with standard test concentrations. It has been shown that patients giving a +++ plus or ++ grading at patch testing with the fragrance mix or one of its ingredients are very sensitive and likely to react to normal use of cosmetics containing the allergen, they cannot tolerate.

A total 82.1% of a group of eczema patients, who had been diagnosed with fragrance contact allergy within the past two year, reported some degree of eczema presently. Most had hand eczema (55.5%) followed by facial eczema (33.3%), and 42.7% had eczema at multiple locations (26).

Fragrance allergic patients are advised to use fragrance-free products and should be aware that some products marketed as fragrance-free in spite of this may contain fragrance ingredients. These are often various flower or plant extracts or chemicals acting as preservatives (27). Such products may cause adverse reactions in the perfume allergic patients. Often, it is possible by the (pleasant) scent of the product to tell if it contains fragrance ingredients.

### INTERVENTIONS AND REGULATIONS

The International Fragrance Association (IFRA) was founded in 1973 by fragrance manufacturers and has since issued recommendations for the safe use of fragrance ingredients. Guidelines for more than 100 ingredients are published ([www.ifraorg.org](http://www.ifraorg.org)). Most recommendations are due to skin effects especially allergic contact dermatitis. In spite of these guidelines fragrance ingredients still are one of the most frequent causes of allergic contact dermatitis. Fragrance industry has developed new models for the estimation of exposure levels, which does not sensitize (28). The efficacy of these models is unknown, and already sensitized consumers will not be protected.

In Europe, ingredient labeling of cosmetics was introduced in 1997, while it has been in force in the United States for decades. In both cases, fragrance compositions were referred by the word "parfum," and no disclose of the individual fragrance ingredients was given. By the last amendment of the Cosmetic Directive in Europe (2003), labeling of certain fragrance ingredients recognized for their sensitizing potential has been introduced (Table 19.2) to improve the diagnostics and help the

**Table 19.2** Fragrance Ingredients Included in the List of Substances to be Labeled as Ingredients If Present in Cosmetics in Europe and Their Inclusion in Diagnostic Test Preparations

Name (INCI)	CAS no.	In FM I	In FM II
Amyl cinnamal	122-40-7		
Benzyl alcohol	100-51-6		
Cinnamyl alcohol	104-54-1	X	
Citral	5392-40-5		X
Eugenol	97-53-0	X	
Hydroxycitronellal	107-75-5	X	
Isoeugenol	97-54-1	X	
Amylcinnamyl alcohol	101-85-9	X	
Benzyl salicylate	118-58-1		
Cinnamal	104-55-2	X	
Coumarin	91-64-5		X
Geraniol	106-24-1	X	
Hydroxyisohexyl 3-cyclohexene carboxaldehyde (Lyral)	31906-04-4		X
Anisyl alcohol	105-13-5		
Benzyl cinnamate	103-41-3		
Farnesol	4602-84-0		X
Butylphenyl methylpropional	80-54-6		
Linalool	78-70-6		
Benzyl benzoate	120-51-4		
Citronellol	106-22-9		X
Hexyl cinnamal	101-86-0		X
D-Limonene	5989-27-5		
Methyl 2-octynoate	111-12-6		
Alpha isomethyl ionone	127-51-5		
<i>Evernia prunastri</i> (oakmoss extract)	90028-68-5	X	
<i>Evernia furfuracea</i> (treemoss extract)	90028-67-4		

Abbreviation: INCI, International Nomenclature of Cosmetic Ingredients.

FM, mixture of fragrance ingredients used for diagnosing fragrance allergy.

The presence of the substance must be indicated in the list of ingredients, when its concentration exceeds 0.001% in leave-on products and 0.01% in rinse-off products according to the Cosmetic Directive in EU (<http://ec.europa.eu/enterprise/cosmetics/cosing>). Information regarding the presence of other fragrance ingredients in cosmetics may be made available by fragrance industry on a case basis (29).

sensitized consumer to avoid relevant allergens. The list is currently under revision, and substances may both be in and excluded. A number of other fragrance ingredients have been restricted in use mainly because of their sensitizing properties or have been banned from use in cosmetic products (<http://ec.europa.eu/enterprise/cosmetics/cosing>).

A decline in contact allergy to FMI and MP has been noted (7,18,30), which may to some extent be an effect of these actions, change in fashion and other initiatives; however, as new causative ingredient has been identified (FMII/HICC), the collective sum of fragrance allergy seems unchanged.

## REFERENCES

- Harder U. The art of creating a perfume. In: Frosch PJ, Johansen JD, White IR, eds. *Fragrances-Beneficial and Adverse Effects*. Berlin: Springer-Verlag, 1998:3-5.
- Elberling J, Dirksen A, Johansen JD, et al. The capsaicin cough reflex in eczema patients with respiratory symptoms elicited by perfume. *Contact Dermatitis* 2006; 54(3):158-164.
- Tanaka S, Matsumoto Y, Dlova N, et al. Immediate contact reactions to fragrance mix constituents and Myroxylon pereirae resin. *Contact Dermatitis* 2004; 51(1):20-21.
- Johansen JD. Contact allergy to fragrances: clinical and experimental investigations of the fragrance mix and its ingredients. *Contact Dermatitis* 2002; 46(suppl 3):1-31.
- de Groot AC, Frosch PJ. Adverse reactions to fragrances. A clinical review. *Contact Dermatitis* 1997; 36:57-87.
- Schnuch A, Uter W, Geier J, et al. Epidemiology of contact allergy: an estimation of morbidity employing the clinical epidemiology and drug utilization research (CE-DUR) approach. *Contact Dermatitis* 2002; 47:32-39.
- Thyssen JP, Linneberg A, Menné T, et al. The prevalence and morbidity of sensitization to fragrance mix I in the general population. *Br J Dermatol* 2009; 161(1):95-101. [Epub April 24, 2009].
- Mortz CG, Lauritsen JM, Bindslev-Jensen C, et al. Contact allergy and allergic contact dermatitis in adolescents: prevalence measures and associations. *Acta Derm Venereol* 2002; 82:352-358.
- Larsen W, Nakayama H, Fischer T, et al. A study of new fragrance mixtures. *Am J Contact Dermatitis* 1998; 9:202-206.
- Frosch PJ, Johansen JD, Menné T, et al. Further important sensitizers in patients sensitive to fragrances. II. Reactivity to essential oils. *Contact Dermatitis* 2002; 47:279-287.
- Larsen W, Nakayama H, Lindberg M, et al. Fragrance contact dermatitis: a worldwide multicenter investigation, part I. *Am J Contact Dermatitis* 1996; 7:77-83.
- Larsen WG. How to test for fragrance allergy. *Cutis* 2000; 65:39-41.
- Frosch PJ, Johansen JD, Menné T, et al. Further important sensitizers in patients sensitive to fragrances. I. Reactivity to 14 frequently used chemicals. *Contact Dermatitis* 2002; 47:78-85.
- Frosch PJ, Pirker C, Rastogi SC, et al. Patch testing with a new fragrance mix detects additional patients sensitive to perfumes and missed by the current fragrance mix. *Contact Dermatitis* 2005; 52:207-215.
- Frosch PJ, Rastogi SC, Pirker C, et al. Patch testing with a new fragrance mix-reactivity to the single constituents and chemical detection in relevant cosmetic products. *Contact Dermatitis* 2005; 52:216-225.
- Frosch PJ, Johansen JD, Menné T, et al. Lyréal<sup>®</sup> is an important sensitizer in patients sensitive to fragrances. *Br J Dermatol* 1999; 141:1076-1083.
- Bruze M, Andersen KE, Goossens A. Recommendation to include fragrance mix 2 and hydroxyisohexyl 3-cyclohexene carboxaldehyde (Lyréal<sup>®</sup>) in the European Baseline patch test series. *Contact Dermatitis* 2008; 58:129-133.
- Nardelli A, Carbonez A, Ottroy W, et al. Frequency of and trends in fragrance allergy over a 15-year period. *Contact Dermatitis* 2008; 58(3):134-141.
- Belsito DV, Fowler JF Jr, Sasseville D, et al. Delayed-type hypersensitivity to fragrance materials in a select North American population. *Dermatitis* 2006; 17(1):23-28.
- Johansen JD, Andersen TF, Kjølner M, et al. Identification of risk products for fragrance contact allergy. A case-referent study based on patients' histories. *Am J Contact Dermatitis* 1998; 2:80-87.
- Uter W, Geier J, Schnuch A, et al. Patch test results with patients' own perfumes, deodorants and shaving lotions: results of the IVDK 1998-2002. *J Eur Acad Dermatol Venereol* 2007; 21(3):374-379.
- Buckley DA. Fragrance ingredient labelling in products on sale in the U.K. *Br J Dermatol* 2007; 157(2):295-300.
- Api AM. Only Peru Balsam extracts or distillates are used in perfumery. *Contact Dermatitis* 2006; 54(3):179.
- Bernard G, Giménez-Arnau E, Rastogi SC, et al. Contact allergy to oak moss: search for sensitizing molecules using combined bioassay-guided chemical fractionation, GC-MS, and structure-activity relationship analysis. *Arch Dermatol Res* 2003; 295:229-235.
- Hagvall L, Bäcktorp C, Svensson S, et al. Fragrance compound geraniol forms contact allergens on air exposure. identification and quantification of oxidation products and effect on skin sensitization. *Chem Res Toxicol* 2007; 20:807-814.
- Lysdal SH, Johansen JD. Fragrance allergic patients -strategies for use of cosmetic products and perceived impact on life situation. *Contact Dermatitis* 2009; 61:320-324.
- Scheinman PL. The foul side of fragrance-free products: what every clinician should know about managing patients with fragrance allergy. *J Am Acad Dermatol* 1999; 41:1020-1024.
- Basketter DA. Skin sensitization: strategies for the assessment and management of risk. *Br J Dermatol* 2008; 159(2):267-273 [Epub May 22, 2008].
- Roberts G. Procedures for supplying fragrance information to dermatologists. Letter to the editor. *Am J Contact Dermat* 2002; 13: 206-207.
- Thyssen JP, Carlsen BC, Menné T, et al. Trends of contact allergy to fragrance mix I and Myroxylon pereirae among Danish eczema patients tested between 1985 and 2007. *Contact Dermatitis* 2008; 59(4):238-244.

# Do consumer relevant exposures to geraniol cause clinical allergic contact dermatitis in man?<sup>1</sup>

Jurij J. Hostynek and Howard I. Maibach

## INTRODUCTION

Geraniol has been cited as a moderately frequent cause of allergic contact dermatitis. The following reviews the published data on the sensitization potential of geraniol: 2,6-octadien-1-ol, 3,7-dimethyl-, (E)-, (CASRN: 106-24-1, EINECS 203-377-1). A semiquantitative evaluation of the different reports cited below has been made in accordance with the rules outlined by Hostynek and Maibach (1), which are based on procedures suggested by Benezra et al. in 1985 (2).

## METHODS

The medical literature was searched using the electronic databases Biosis, Caplu, Embase, RTECS, Toxlit, Medline/HealthStar, Toxnet, and Science Citation Index (1960 to September 2009). Search terms included "geraniol," "allergic contact dermatitis," "sensitization," and "patch tests." Copies of all cited publications were obtained except for *Annali Italiani Dermatologia Allergologia* and *Bolletino Dermatologia Allergologica e Professionale-Manuela Pangrazio* for which back copies were not available. The Research Institute for Fragrance Materials Inc. (RIFM) kindly made available copies of unpublished studies performed by its members or carried out under its commission (3,4).

## RESULTS

### Data from Predictive Tests Carried Out on Animals

Several animal tests have been reported.

Several local lymph node assays have been performed on geraniol. These studies were given a degree of confidence of 4, even though it is not certain that the differences between these estimated concentration (EC<sub>3</sub>) values are significant. It can be concluded with a good degree of confidence that geraniol is a moderate to weak sensitizer according to local lymph node assay (LLNA) tests.

Lalko and Api (5) used the local lymph node assay to evaluate the dermal sensitization potential of basil, citronella, clove leaf, geranium, litsea cubeba, lemongrass, and palmarosa oils. Also geraniol, one of the major components at 4.9%, was included in the study to observe any difference in sensitization potential from its exposure in a mixture. The EC<sub>3</sub> required to elicit a positive was calculated and taken as a measure of relative potency. Geranium oil was negative; geraniol itself

resulted in an EC<sub>3</sub> value of 11.4%. In general, the potency of each essential oil did not differ significantly from that observed for its main individual component. The local lymph node assay was conducted on female mice according to the method of Kimber et al. (6-8), as formalized in OECD Guideline 429 (OECD, 2002). Geraniol was observed to result in a dose-dependent induction of lymph node cell (LNC) proliferation and SI values of greater than 3 in one or more of the concentrations tested; therefore, it can be regarded as a potential skin sensitizer. Both the individual components and their related essential oils studied were observed to have the potential to induce skin sensitization with a wide range of EC<sub>3</sub> values. Geraniol is classified as a weak sensitizer in the LLNA, but geranium oil was not observed to elicit a positive response and can be considered to be nonsensitizing at the concentrations tested. In general, the potency of each essential oil reported in that study did not differ significantly from the potency of the main individual component, and no evidence of the "quenching" phenomenon could be observed.

*The LLNA test as conducted is rated at level 4.*

Guinea pig maximization tests have been carried out. *In the case of guinea pig maximization tests, the tests that were most highly maximized and to which we attribute the highest degree of confidence showed that geraniol is incapable of causing any significant reactions (9).*

### Predictive Tests Performed on Human Volunteers

A human maximization test carried out on 25 volunteers at a concentration of 6% in petrolatum gave no reactions (10). However, this study was probably carried out under submaximized conditions and is given a rating of 2. Human maximization tests carried out under the same conditions on Japanese-American subjects gave one possible reaction in 26 volunteers (24) and none in a further 24 volunteers (3). These studies were also rated at 2. A modified Draize sensitization screen of geraniol in ethanol at 10% was reported to give 2 reactions in 73 volunteers but none in 104 volunteers when tested at the same concentration in petrolatum (11). *The higher concentration allows a rating of 3 to be accorded to these.* A human repeat insult patch test carried out at 5% in ethanol gave no reactions in 40 subjects (12). Another human repeat insult patch test carried out at only 2% in ethanol/diethyl phthalate (1:3) also gave no reactions (3). Both of these *human repeat insult patch tests were rated at 2 because of the low dose. In summary, the seven human predictive studies indicate a weak or absent sensitization potential.*

<sup>1</sup> This chapter is a revised and updated version of Hostynek JJ, Maibach HI. Is there evidence that geraniol causes allergic contact dermatitis? *Exog Dermatol* 2004; 3:318-331, with permission from S Karger AG.



### Clinical Elicitation Tests on Human Patients

Short reviews have been published (13,14). Because of its presence as one of the eight components of the fragrance mix, there are, not unsurprisingly, numerous reports of studies in which geraniol has been used in routine patch testing. An attempt has been made to include all reported cases.

#### Tests Producing Reactions

The following reports indicate positive elicitation reactions to geraniol.

One patient of 75 who reacted to different fragrance and cosmetic ingredients (taken from 1781 patients over a 6-year period) also reacted to geraniol at an unspecified concentration (probably 5%) (15). *Only 32 of these patients gave any reactions at all, but this group still gave 82 positive reactions. A rating of 2 was given to this publication, which is more of a review of 11 publications by the same group.*

Two patients of 119 who reacted to different fragrance and cosmetic ingredients also reacted to closed patches containing geraniol at 5% (16). *In fact only 53 patients reacted to any of the test materials but a total of 147 reactions were observed. This report indicates that parts of these results have already been published by these authors in seven other reports some of which are indicated above. These reactions that were given a rating of 2 may therefore have been reported twice in this review.*

One of two patients who had reacted to products containing citronella oil reacted to 1% geraniol (17). *In this study however, stronger reactions were seen to citronellal at 1% and to some other substances. A rating of 2 was given as the evidence points to other components of citronella oil.*

Five out of 167 patients in a three-year multicenter study exhibited allergic reactions to 5% geraniol with 7 patients showing irritant reactions (18). *This study showed a high degree of polyreactivity. The reacting patients reacted to an average of 4.5 of the test materials. A rating of 2 was given.*

In a study on a mixed group of 50 healthy and eczematous patients (the latter being divided into those with cosmetic allergy and those with other allergies), a number of immediate reactions were seen in open testing to 5% geraniol but only one reaction was seen after closed patch testing (19). This reaction of unknown severity was not associated with any particular product and was experienced by a patient in the group who had no history of cosmetic allergy. A rating of 2 was given.

In a study performed on 747 patients with "suspected fragrance allergies," 7 reacted to 1% geraniol (20). This study was associated with a high degree of polyreactivity. No information was given on the severity of the reactions, and there was no linkage to products containing geraniol, which may have been responsible for these reactions. As a consequence, a degree of confidence of 2 was attributed.

A study (21) showed that 6 out of 20 perfume-sensitive patients reacted to this substance when tested at 5%. *However, this report indicated that these six patients all reacted to other test materials most notably, hydroxycitronellal. No indications were given in relation to the relative severity of these different reactions. Later studies (18) have shown that at 5% may be too high and produces irritant reactions. As a result, a degree of confidence of 2 was given.*

An occupational exposure to lemon peel gave allergic reactions in a bakery worker who failed to react to most components of lemon peel (citral, limonene, terpineol, linalool, citronellol) but who did react to 5% geraniol with an intensity that was approximately commensurate with reactions to 10%

lemon oil and 10% citronella oil (22). *The lack of test details and the absence of any test to citronellal reduce the degree of confidence to 3.*

In a study on 5202 patients, 11 reacted to an undisclosed concentration of geraniol but only 2 of these reactions were experienced by patients with a history of cosmetic allergy (23). *257 reactions were experienced by 156 of these patients. No information was given on the severity of the reactions, and there was no linkage to products containing geraniol, which may have been responsible for these reactions. As a consequence, a degree of confidence of 2 was attributed.*

In a 10-year study on reactions to the individual components of the fragrance mix in 283 fragrance mix positive patients, 19 reactions were seen to 1% geraniol (24). *233 reactions were experienced by the 133 patients who reacted to any of the components with 73 patients experiencing reactions to more than 2 components. No information was given on the severity of the reactions, and there was no linkage to products containing geraniol, which may have been responsible for these reactions. As a consequence, a degree of confidence of 2 was attributed.*

In another study of reactions to the individual components of the fragrance mix in 50 fragrance mix-positive patients, 2 delayed-type reactions were seen to an unknown concentration of geraniol (25). *Thirty-one reactions were experienced by the 20 patients who reacted to any of the components. No information was given on the severity of the reactions, and there was no linkage to products containing geraniol, which may have been responsible for these reactions. As a consequence, a degree of confidence of 2 was attributed.*

In a five-year multicenter study involving tests on 713 patients with cosmetics dermatitis, 87 individual ingredients were patch tested on 53% of these (378 patients) giving 8 cutaneous reactions to geraniol at an unspecified concentration (81% of all observed reactions were judged to be genuine sensitization reactions) (26). *No information was given on the severity of the reactions, and there was no linkage to products containing geraniol, which may have been responsible for these reactions. As a consequence, a degree of confidence of 2 was attributed.*

Patch testing over 15 years on 402 consecutive patients gave one reaction to 1% geraniol that was tested on 41 of these patients (27). *One hundred and twenty-two reacted to 17 individual fragrance materials were experienced by between 59 and 20 patients. No information was given on the severity of the reactions, and there was no linkage to products containing geraniol, which may have been responsible for these reactions. As a consequence, a degree of confidence of 2 was attributed.*

Two fragrance mix-sensitive patients gave delayed type reactions to 2% geraniol, whereas eight suffered immediate type urticarial reactions (28). *The two patients experienced reactions to 3 and 5 other components of the fragrance mix (in some cases with more severe reactions). There was no linkage to products containing geraniol, which may have been responsible for causing these allergies. As a consequence, a degree of confidence of 2 was attributed.*

In a study on 5315 consecutive patients, 299 were found to be sensitive to the fragrance mix and of these, 42 were further tested with 35 essential oils and with the 8 components of the fragrance mix. Ten patients reacted to 2% geraniol (29). *One hundred and seventy-four reactions were experienced by the 42 patients to the 35 essential oils, and 89 reactions were experienced to the 8 components of the fragrance mix. These ten patients may have reacted to other substances and essential oils. No information was given on the severity of the reactions, and there was no linkage to products containing geraniol that may have been responsible for these reactions. As a consequence, a degree of confidence of 2 was attributed.*

Three out of seven fragrance mix-sensitive patients reacted to 2% geraniol (30). *These patients reacted however to 17, 22, and 14 different substances and essential oils as well. No information was given on the severity of the reactions, and there was no linkage to products containing geraniol, which may have been responsible for these reactions. As a consequence, a degree of confidence of 2 was attributed.*

In a multicenter study on the effects of sorbitan sesquiolate (SSO), 702 patients were tested with 1% geraniol with and without SSO (31). In the absence of SSO, 3 patients gave allergic reactions to geraniol, while 5 experienced allergic reactions to geraniol mixed with SSO. Six patients who had experienced doubtful or irritant reactions to geraniol and SSO failed to react to geraniol in the absence of SSO. Repeated open application testing (ROAT) or two of the patients who had reacted to geraniol failed to confirm positivity to geraniol. *A confidence rating of 2 was ascribed to this report as an indication of the causality of geraniol.*

Although a multicenter study failed to show reactions to geraniol at 1% and 0.1%, this report (32) cites the results of testing 1072 patients in the 9 participating clinics with the components of the fragrance mix. These results that may include positives reported elsewhere indicate that eight patients gave positive reactions to 1% geraniol in the presence of SSO. A further 4 patients gave doubtful/irritant reactions. *The data are by necessity summarized and not linked to possibly causative products. A confidence rating of 2 was ascribed to this report as an indication of the causality of geraniol.*

When 162 patients who were sensitive to the fragrance mix were tested to their individual components, 69 of them gave reactions (33). Only 4 of these reacted to 1% geraniol, and these patients also experienced reactions to the fragrance mix and a further 10 reactions to the other components indicating a high degree of polyreactivity. *The data are highly summarized and not linked to possibly causative products. A confidence rating of 2 was ascribed to this report as an indication of the causality of geraniol.*

In a study on the causes of eyelid dermatitis, 19 patients suffering from this condition were patch tested to 25 fragrance materials and gave no positive reactions to 2% geraniol (34). Tests on 51 cases of dermatitis at other sites gave 2 reactions to the same material. *The data are highly summarized with no indication of severity of the reactions being given, and these are not linked to possibly causative products. A confidence rating of 2 was ascribed to this report as an indication of the causality of geraniol.*

Patch testing on 40 patients to 2% geraniol gave one reaction (35). *Three hundred and thirty-eight reactions were experienced by the 80–27 patients who were tested with 28 different materials. No information was given on the severity of the reactions, and there was no linkage to products containing geraniol, which may have been responsible for these reactions. As a consequence, a degree of confidence of 2 was attributed.*

In a summary of patch testing at St. John's Hospital in which patch testing was performed on 2461 patients in 1979–1980 and 1836 patients in 1984 [results that may also have been reported by other workers such as Calnan et al. (36)], patients reacted to 2% geraniol in the first period and 10 reacted in the second (37). *No information was given on the severity of the reactions, and there was no linkage to products containing geraniol, which may have been responsible for these reactions. As a consequence, a degree of confidence of 2 was attributed.*

A study of 15 patients sensitive to Peru Balsam showed that two reacted to 10% geraniol and one reacted in 253 normal controls (38). *No information was given on the severity of the*

*reactions particularly with regard to the patient's reaction to Peru Balsam. There was no linkage to products containing geraniol, which may have been responsible for these reactions. As a consequence, a degree of confidence of 2 was attributed.*

Patch test and photopatch test studies in Japan over one year showed that 5% geraniol produced one reaction in 111 patients in normal patch testing and no reactions in photopatch testing on the same patients (39). *Although the frequency of reactions to different types of products is given, there is no linkage to the products containing geraniol, which may have been responsible for these reactions. As a consequence, a degree of confidence of 2 was attributed.*

In another study using 5% geraniol, 3 of 64 cosmetic-sensitive patients reacted while one out of 32 patients with dermatitis unrelated to cosmetics reacted and no normal subjects in a control group reacted (40). *No information was given on the severity of the reactions, and there was no linkage to products containing geraniol, which may have been responsible for these reactions. As a consequence, a degree of confidence of 2 was attributed.*

In a six-year study in Japan on patients who had suffered from pigmented allergic dermatitis, 7 patients out of 123 (presumably not the same patients returning each year) reacted to the surprisingly high level of 20% geraniol (41). *Here too, there is insufficient evidence to establish a clear causal link between these reactions and the condition of the patients. A rating of 2 was attributed.*

In further studies in Japan (42), geraniol at 5% and 2% failed to elicit reactions in 45 patients suffering from melanosis facia. However in a group of 120 patients suffering from cosmetics-related dermatitis, 2 reacted to 5% geraniol but none reacted to 2%. Similarly, in a group of 78 patients suffering from cosmetics-unrelated dermatitis, one reacted to 5% geraniol but none reacted to 2% geraniol (42). *The disappearance of reactions at the lower concentration erodes the degree of confidence further in addition to the absence of information on potential causative products (rating of 2).*

A patient who reacted to a roll on deodorant, reacted also to the fragrance and a fraction of the fragrance containing lilyal and geraniol; subsequently reacting to both of these substances on their own at 1% (43). *Reactions to lilyal were more intense and of longer duration than to geraniol. It was concluded that the causative agent was lilyal because the allergy to geraniol was apparently developed during the patch testing. The reaction to geraniol was concluded as being not clinically relevant and a rating of 1 is therefore given.*

One patient of 242 reacted to geraniol at 1% (44). *This reaction was not linked to any potentially causative product and a rating of 2 is ascribed.*

In another study on facial melanosis in Japan, 35 patients with this condition failed to react to 5% geraniol (45). However, 2 patients from a group of 212 with cosmetics-related dermatitis and one from a group of 275 with cosmetics-unrelated dermatitis did react. A control group of 101 normal subjects failed to produce any reactions to this substance. *There was no linkage to products containing geraniol, which may have been responsible for these reactions. As a consequence, a degree of confidence of 2 was attributed.*

Studies on 1200 dermatitis patients in Italy in 1983–1984 showed that of 63 patients who reacted to the fragrance mix, 43 reacted to at least one of the individual components (giving 77 reactions) and of these, 4 reacted to geraniol at 3% (46). In the second series involving 1500 patients in 1984–1985, 54 reacted to the fragrance mix and 45 of these reacted to at least one of the

individual components (58 reactions) and of these, one reaction was to geraniol at 1%. *In view of the polyreactivity, the causality of geraniol in these cases could not be clearly established. Furthermore there was no linkage to causative products containing geraniol, allowing a rating of 2 to be attributed.*

In studies on 757 patients of whom 112 reacted to the fragrance mix, 50 of these reacted to the individual components of this mix and of these, three reacted to 2% geraniol in petrolatum with SSO (47). *There was some degree of polyreactivity because these 50 patients experienced 75 reactions to these components. Again, there was no linkage to causative products that may have contained geraniol and hence a rating of 2 was given to this report.*

In a study on 4975 consecutive patients, 407 reacted to the fragrance mix and from these, 38 patients were tested with the individual ingredients giving 5 reactions to 1% geraniol (48). *In fact only 32 of these subjects reacted to any of the components, giving rise to 75 reactions. In view of this degree of polyreactivity and as no linkage to causative products, which may have contained geraniol, was made, a rating of 2 was given to this report.*

In a study on 247 patients, 10 reacted to 2% geraniol (out of 147 reactions to different fragrance materials experienced by this group (49). *This study was not designed to determine the causative allergens and was considered to attribute causality for these patients' allergies with a degree of confidence of 2.*

In a prospective study of cosmetic reactions from 1977 to 1980 487 patients gave 5 reactions (out of 338 reactions observed) to an unspecified concentration (probably 2%) of geraniol (50). *These positive reactions may also be taken up in the report of Adams and Maibach (26), and like this report (although it summarizes some detailed investigations that linked allergies to specific products through provocative product use tests), this one is also attributed with a rating of 2.*

In studies on 2461 consecutive patients during 15 months, 7 reactions were ascribed to 2% geraniol (36). *Only 172 patients reacted to the fragrance mix (38), but 338 reactions were seen to its eight constituents. Although the authors state that "most of the positive reactions were relevant to the patient's present or past dermatitis," insufficient information is given in this report to substantiate this and as a result, a rating of 2 was ascribed.*

In a study of patch test reactions over 14 years (1979–1992) in which 8215 consecutive patients were tested and gave 449 positive reactions to the fragrance mix, when 367 of these patients were tested with the individual constituents of the fragrance mix, 15 reacted to geraniol at 2% until in 1984 and from then on at 1% with a further 14 doubtful reactions (51). *A total of 338 positive and 142 doubtful reactions were observed in the 224 patients who reacted to one or more of these constituents. No linkage is made to possibly causative products, and this report only provides a level of confidence of 2 in determining that geraniol was the causative agent.*

Another study on 200 fragrance mix-sensitive subjects drawn from 1967 dermatitis patients produced 14 reactions (out of 310 observed when 7 of the 8 constituents of the fragrance mix were tested individually) to geraniol at a concentration of 1% or 3% (52). *In view of the polyreactivity and the absence of any established linkage of these reactions to causative effects or products, a low level of confidence (2) can only be ascribed.*

In 61 patients out of 677 patch tested, 61 reacted to the fragrance mix and when these were tested with the 8 individual constituents, 8 reacted to 5% geraniol (out of 111 reactions recorded to the different constituents) were recorded (53). *Although this study revealed some interesting aspects of patch testing,*

*it can only be given a level of confidence of 2 in attributing direct causality to geraniol for the allergies detected in these 8 patients.*

In a study on dentists and dental nurses in which 180 patch test reactions were observed in 72 female dentists who had presented cases of suspected occupational allergic contact dermatitis, one reaction was seen to geraniol. No reactions were seen to dental nurses (54). *It is not known whether this patient reacted to other materials or whether any attempt was made to assess the clinical relevance of this case. For this reason, a rating of 2 was ascribed.*

In a study on 179 cosmetic-sensitive patients, 67 reacted to 22 substances (giving 116 reactions) including 11 to a high concentration of geraniol (10%) (55). *There was clearly a high degree of polyreactivity, and the authors discount the high concentration as a cause for the relatively high frequency of reactions as 11 out of 179 is too low to represent false positives. No linkage was made to possibly causative products, and this report only provides a level of confidence of 2 in determining that geraniol was the causative agent.*

In a summary of four years of patch testing in 23,660 patients of whom 1811 reacted to the fragrance mix, patch testing of the individual components of this mix, giving rise to 1294 reactions in 934 patients who reacted to at least one of these constituents. Patches containing 1% geraniol and 1% SSO produced 67 reactions to geraniol (SSO on its own at 1% in petrolatum produced 35 reactions (56). *A degree of confidence of 2 was ascribed to this study, which did not detail any results that linked these reactions to causative products.*

Examination of the results of patch testing 3037 out of 8230 consecutive patients with the fragrance mix between 1968 and 1983 led to further tests on 144 fragrance mix positive patients using the 8 individual components. Of these 10 reactions (out of 133 to the 123 patients who reacted to one or more constituents) to 1% geraniol (57). *No record was made of linkage of any of these reactions to causative products. As a result, a rating of 2 has been ascribed.*

In a study aimed more at investigating possible causes of phototoxicity dermatitis with actinic reticuloid syndrome, 3 subjects out of 457 reacted to 2% geraniol (58). *In all, 47 patients experienced a total of 72 reactions. No link was made to possible causes, and as a result, a level of confidence of 2 has been ascribed.*

A total of 5 reactions to geraniol in 31 oakmoss-sensitive patients were ascribed by the authors as concomitant positive reactions (59). *Further more, these 31 patients experienced 75 reactions to other substances. This was also ascribed a rating of 2.*

Two patients who had suffered reactions to specific qualities of essential oils used in aromatherapy were found to react to 2% geraniol (60). One of these patients reacted to 6 other substances (3 more strongly than her reaction to geraniol) and 32 essential oils (19 more strongly). Twenty-one of these essential oils did not contain detectable levels of geraniol. The other patient reacted to 5 other substances (one more strongly than to geraniol) and 21 essential oils (7 more strongly). Most of her essential oils were not analyzed for the presence of geraniol but 9 oils that had produced reactions contained no detectable levels of geraniol. *In view of the number of reactions, each patient produced to other substances or to oils containing no detectable geraniol levels, only a rating of 2 was ascribed.*

In a review of testing in 31 clinics in Germany on 4900 patients over four years (61), 20 patients out of 566 who had given a 1+ reaction to the fragrance mix reacted to 1% geraniol. A further 34 out of another 425 patients who had given 2+ or 3+ reactions to the fragrance mix reacted to the same substance, but only 8 of these gave more than a 1+ reaction to geraniol. *It*

is not clear from these studies whether geraniol had any responsibility at all for the cause of the patients' allergies and for this reason, a score of 2 has been assigned.

In a study on 133 fragrance mix-sensitive patients drawn from 2600 patients who had been routinely patch tested over a 10-year period, 19 reacted (out of 233 reactions observed when the individual components of the fragrance mix were tested) to geraniol at 1% (24). *No linkage was made to specific products containing this ingredient and 233 reactions were observed in only 133 patients, leading to a level of 2 being ascribed.* These same results were reported in another paper cited here (62).

In a study on 542 fragrance mix-sensitive patients drawn from 12118 patients who had been routinely patch tested in 10 centers, 58 reacted (out of 623 reactions observed when the individual components of the fragrance mix were tested) to geraniol at an unknown concentration (63). *No linkage was made to specific products containing this ingredient and the possibility of cross reactions was not ruled out. Furthermore, 623 reactions were observed in only 542 patients, leading to a level of 2 being ascribed.*

A small proportion (0.4%) of a group of 792 eczematous patients (presumably 3) reacted to 10% geraniol (64). *The lack of detail as to possible concurrent reactions suffered by these patients as well as any linkage to past exposure to particular products allows a rating of only 2.*

Single compounds (SCs) in a fragrance mix contribute differently to patch test reactions. Schnuch et al. (65) were interested in the time trends of fragrance materials and single compounds and analyzed data collected by the Information Network of Departments of Dermatology multicenter project in Germany from 1996 to 2002 on 11,789 patients. There was no time trend in reactions to SC, Frequencies of sensitization in patients tested with SCs showed a relatively stable proportion for most of the compounds tested, except for the proportions of patients sensitized against geraniol that increased and peaked in 1999 (8.2%). The authors conclude that this may be ascribed to the increased importance of that compound in the fragrance mix in that year. Data relating the patch test frequency to clinical relevance was not presented. *The lack of detail in clinical data allows a rating of only 2.*

Schnuch et al. (66) studied the frequency of sensitization to 26 fragrances to be labeled according to current European regulation. During 4 periods of 6 months, from January 1, 2003 to December 31, 2004, 26 fragrances were patch tested additionally to the standard series in a total of 21,325 patients. The sensitization rate observed for geraniol was 0.4%, standardized for sex and age. In view of some of the results, the authors propose that the decision of the EU on labeling 26 compounds (because they were considered as allergens) should be revised. As in their 2004 publication (5), data relating patch test frequency to clinical relevance was not provided. *The lack of detail in clinical data allows a rating of only 2.*

Juarez et al. (67) describe a patient who developed allergic contact dermatitis on his leg with secondary spreading after he used a topical medication containing geraniol and lavender essence. Diagnosed with disseminated allergic contact dermatitis, the patient developed an allergic contact dermatitis on his leg (the application site), but there was spreading over extensive regions of the legs, arms, and trunk, ascribed to the application of Blastoestimulina cream, showing a strongly positive reaction to geraniol among similar reactions to other fragrance components. *Details are too few to relate to causation; rated as 2.*

To determine which topical pharmaceutical products marketed in Belgium contain fragrances and to gain insight

into the nature of the fragrance allergens in specific pharmaceutical products having caused iatrogenic contact dermatitis (68), examined data of 18,960 patients investigated for contact allergy between 1978 and 2008. The subjects included were those who presented with iatrogenic contact dermatitis from a specific pharmaceutical product and for whom a positive reaction was found to be due to a fragrance allergen present. Among the 127 patients included were those who presented with iatrogenic contact dermatitis from a specific pharmaceutical product and for whom a positive reaction was attributed to a fragrance allergen present. Four among 48 specific topical pharmaceutical products in question were shown to contain geraniol. *The study is rated 3.*

## Tests Producing No Reactions

A number of studies on patients failed to produce positive reactions to geraniol when this was one of the patch tested substances. A nonexhaustive list is provided here.

Tests carried out at a concentration of 1%: unspecified number of patients (69); 0/667 (44), 0/14 (70); 0/8 (71); 0/47 (72); 0/170 (73). Tests carried out at 2%: 0/336 (74). Tests carried out at 5%: 0/115 (75); 0/122 (76), and tests carried out at 8% (77).

## Regulatory and Industrial Classification

Lapczynski et al. (78) reviewed the classifications of geraniol by various regulatory agencies and industry associations:

COE: Geraniol was included by the Council of Europe in the list of substances granted A—may be used in foodstuffs (COE No. 60).

FEMA: Flavor and Extract Manufacturers' Association: Generally Recognized as Safe as a flavor ingredient—GRAS 3 (FEMA, 1965).

FDA: Geraniol was approved by the FDA as GRAS (21 CFR 182.60).

JECFA: The Joint FAO/WHO Expert Committee on Food Additives (JECFA No. 1223) concluded that the substance does not present a safety concern at current levels of intake when used as a flavoring agent (JECFA, 2004).

An exposure-based quantitative risk assessment (QRA) methodology has been used to determine acceptable exposure limits for geraniol and a new IFRA Standard (IFRA, 2007) has been issued. *Review only; does not obtain a rating.*

## DISCUSSION

Data from predictive tests in animals on geraniol do not indicate a significant sensitization potential. With the exception of local lymph node assays, the tests with which we were able to assign a high degree of confidence were negative. The low potential was confirmed by predictive tests in humans although these generally inspire lower degrees of confidence as they cannot be maximized to the same degree as animal tests.

No single study investigated cases where patients have reacted to specific products containing this substance. Nearly all of the clinical studies reported here have been aimed at goals other than simply determining the original cause of the patients' allergies and have often involved well-designed studies aimed at determining the relationship between positive reactions to the fragrance mix and reactions to its individual constituents. Others are simply clinical reports in which patients were subjected to

multiple patch testing and are aimed more at determining the frequency of reaction to the substance and most have not attempted to establish clinical relevance according to currently accepted procedures (79). This is not a criticism of most of these papers that elegantly achieved other goals. They did not set out to determine the role played by geraniol in the etiology of the patient's disease, and hence we are unable to attribute any real degree of confidence to these papers as pointing to the responsibility of geraniol in this regard.

## CONCLUSIONS

Data from predictive tests in animals do not appear to indicate that geraniol is a particularly potent skin sensitizer. Predictive tests in humans were generally negative although some reactions were obtained when ethanol was used in closed chambers. The possible potentiating effect of occluded ethanol (a situation that is not encountered during normal conditions of use of cosmetics) needs further elucidation. A number of clinical reports describe reactions to different concentrations of geraniol in multiple-substance patch testing on prior-sensitized patients. However, these studies are by their nature incapable unambiguously designating geraniol as the cause of the patient's condition. It is, therefore, unlikely that geraniol is a major "fragrance allergen."

Determining the clinical relevance of fragrance patch test positivity presents a challenge to physicians and dermatologists. To diagnose clinical allergic contact dermatitis, two criteria should be considered: (i) demonstrating the presence of delayed hypersensitivity to an allergen and (ii) determining the clinical relevance. Toward this goal, the physician relies on a detailed history, physical examination, and comprehensive skin testing. This process is simplified as more data becomes available as to appropriate nonirritant patch test concentrations and vehicles together with clinical correlations to provocative use test/repeat open application tests (PUT/ROAT) (80). An expedited schema for providing fragrance allergens should be of value (81). The paper by Hostynek and Maibach: "Operational Definition of a Causative Contact Allergen—A Study with Six Fragrance Allergens" (1) provides an algorithm for defining clinical relevance of positive patch tests to fragrance chemicals. The criteria listed show that when the underlying clinical and experimental data are analyzed accordingly, a clear cause-effect relationship has infrequently or rarely been established, nor would one be necessarily expected on the basis of the generally weak sensitizing potential of these substances coupled with reasonably low exposure conditions. This is not to say that some of these substances are frequent inducers of type IV allergy in members of the public. It remains to be seen however, how often such allergy, once established, is responsible for any of the cases of allergic contact dermatitis commonly ascribed to those six substances investigated.

## REFERENCES

- Hostynek JJ, Maibach HI. Operational definition of a causative contact allergen—a study with six fragrance allergens. *Exog Dermatol* 2003; 2:279–285.
- Benezra C, Sigman CC, Perry LR, et al. A systemic search for structure-activity relationships of skin contact sensitizers: methodology. *J Invest Dermatol* 1985; 85:351–356.
- Research Institute for Fragrance Materials, Inc., Report on human maximization studies. Report to RIFM. Unpublished report 1697 from Epstein W.L. June 18–July 06, 1979.
- Research Institute for Fragrance Materials, Inc., Delayed contact hypersensitivity study of geraniol in guinea pigs (Buehler Technique). Report to RIFM. Unpublished report 17636 from Buehler E.V., Morris T.D., Wiseman D.D. and Shuster D.R., 1992.
- Lalko J, Api AM. Investigation of the dermal sensitization potential of various essential oils in the local lymph node assay. *Food Chem Toxicol* 2006; 44:739–746.
- Kimber I, Weisenberger C. A murine local lymph node assay for the identification of contact allergens. *Arch Toxicol* 1989; 63:274–282.
- Kimber I, Basketter D. The murine local lymph node assay: a commentary on collaborative studies and new directions. *Food Chem Toxicol* 1992; 30:165–169.
- Kimber I, Dearman RJ, Scholes EW, et al. The local lymph node assay: developments and applications. *Toxicology* 1994; 93:13–31.
- Klecak G, Geleick H, Frey JR. Screening of fragrance materials for allergenicity in the guinea pig. I. Comparison of four testing methods. *J Soc Cosmet Chem* 1977; 28:53–64.
- Greif N. Cutaneous safety of fragrance material as measured by the maximization test. *American Perfumer and Cosmetics* 1967; 82:54–57.
- Marzulli FN, Maibach HI. Contact allergy: Predictive testing of fragrance ingredients in humans by Draize and maximization methods. *J Environ Pathol Toxicol* 1980; 3(5-6):235–245.
- IFF Incorporated. Repeated insult patch test of geraniol in human subjects. Unpublished report to the Research Institute for Fragrance Materials, 1964.
- Yoshikawa K. Historical data. Summary of past group studies. *Environ Dermatol* 1996; 3:201–203.
- Iwasa M. Allergen explanation: geraniol. *Environ Dermatol* 1999; 6:190–191.
- de Groot AC. Contact allergy to cosmetics: causative ingredients. *Contact Dermatitis* 1987; 17(1):26–34.
- deGroot AC, Bruynzeel DP, Bos JD, et al. The allergens in cosmetics. *Arch Dermatol* 1988; 124:1525–1529.
- Keil H. Contact dermatitis due to oil of citronella. *J Investig Dermatol* 1947; 8:327–334.
- Larsen W, Nakayama H, Fischer T, et al. Fragrance contact dermatitis: a worldwide multicenter investigation. (Part 1). *Am J Contact Dermatitis* 1996; 7(2):77–83.
- Emmons WW, Marks JG. Immediate and delayed reactions to cosmetic ingredients. *Contact Dermatitis* 1985; 13(4):258–265.
- Wöhrl S, Hemmer W, Focke M, et al. The significance of fragrance mix, balsam of Peru, colophony and propolis as screening tools in the detection of fragrance allergy. *Br J Dermatol* 2001; 145: 268–273.
- Larsen WG. Perfume dermatitis: a study of 20 patients. *Arch Dermatol* 1977; 113:623–626.
- Hausen BM, Kulenkamp D. Contact allergy against geraniol. *Zeitschrift Hautkrankheiten* 1990; 65(5):492–494.
- Broeckx W, Blondeel A, Dooms-Goossens A, et al. Cosmetic intolerance. *Contact Dermatitis* 1987; 16:189–194.
- Brites MM, Gonçalo M, Figueiredo A. Contact allergy to fragrance mix—a 10-year study. *Contact Dermatitis* 2000; 43:181–182.
- Becker K, Temesvari E, Nemeth I. Patch testing with fragrance mix and its constituents in a Hungarian population. *Contact Dermatitis* 1994; 30:185–186.
- Adams RM, Maibach HI. A five-year study of cosmetic reactions. *J Am Acad Dermatol* 1985; 13(6):1062–1069.
- Schauder S, Ippen H. Contact and photocontact sensitivity to sunscreens. Review of a 15-year experience and of the literature. *Contact Dermatitis* 1997; 37(5):221–232.
- Safford RJ, Basketter DA, Allenby CF, et al. Immediate contact reactions to chemicals in the fragrance mix and a study of the quenching action of eugenol. *Br J Dermatol* 1990; 123(5):595–606.
- Rudzki E, Grzywa Z. Allergy to perfume mixture. *Contact Dermatitis* 1986; 15(2):115–116.
- Goossens A, Merckx L. Allergic contact dermatitis from farnesol in a deodorant. *Contact Dermatitis* 1997; 37(4):179–180.

31. Frosch PJ, Pilz B, Burrows D, et al. Testing with fragrance mix. Is the addition of sorbitan sesquioleate to the constituents useful? *Contact Dermatitis* 1995; 32(5):266–272.
32. Frosch PJ, Pilz B, Andersen KE, et al. Patch testing with fragrances: results of a multicenter study of the European Environmental and Contact Dermatitis Research Group with 48 frequently used constituents of perfumes. *Contact Dermatitis* 1995; 33(5):333–342.
33. Enders F, Przybilla B, Ring J. Patch testing with fragrance mix at 16% and 8%, and its individual constituents. *Contact Dermatitis* 1989; 20(3):237–238.
34. Nethercott JR, Nield G, Holness DL. A review of 79 cases of eyelid dermatitis. *J Am Acad Dermatol* 1989; 21:223–230.
35. Ohela K, Saramies J. Perfume sensitivity. *Duodecim* 1983; 99: 215–220.
36. Calnan CD, Cronin E, Rycroft RJG. Allergy to perfume ingredients. *Contact Dermatitis* 1980; 6(7):500–501.
37. Cronin E. Allergy to Cosmetics. *Acta Derm Venereol Stockh* 1978; 134:77–82.
38. Hjorth N. Orange peel. In *Eczematous Allergy to Balsams*, chapter 12. Copenhagen: Munksgaard, 1961:124–128.
39. Nagareda T, Sugai T, Shouji A, et al. Incidence of positive reactives to cosmetic products and their ingredients in patch tests and representative case with cosmetic dermatitis in 1991. *Skin Res* 1992; 34(suppl 14):176–182.
40. Haba Y, Itoh M, Morita C, et al. Results of patch tests on cosmetic ingredients conducted in 1990 and 1991. *Hifu [Skin Res]* 1993; 35(suppl 16):65–74.
41. Hayakawa R, Ohiwa K, Ukei C, et al. Melanosis faciei feminae in 1982. *Skin Res* 1983; 25(4):690–695.
42. Ishihara M, Itoh S, Hayashi S, et al. Methods of diagnosis in cases of cosmetic dermatitis and facial melanosis in females. *Nishinohon J Dermatol* 1979; 41(3):426–439.
43. Larsen WG. Allergic contact dermatitis to the fragrance material lilyal. *Contact Dermatitis* 1983; 9:158–159.
44. Van Joost TH, Stolz E, Van Der Hoek JCS, et al. Sensitivity to woodtar. *Contact Dermatitis* 1984; 11(4):248.
45. Nishimura M, Ishihara M, Itoh M, et al. Results of patch tests on cosmetic ingredients conducted between 1979 and 1982. *Skin Res* 1984; 26(4):945–954.
46. Santucci B, Cristaudo A, Cannistraci C, et al. Contact dermatitis to fragrances. *Contact Dermatitis* 1987; 16(2):93–95.
47. Hendriks SA, Van Ginkel CJW. Evaluation of the fragrance mix in the European standard series. *Contact Dermatitis* 1999; 41(3):161–162.
48. Katsarou A. Contact reactions to fragrances. *Annals of Allergy, Asthma and Immunology* 1999; 82:449–456.
49. Ferguson J, Sharma S. Cinnamic aldehyde test concentrations. [Letter to the Editor] *Contact Dermatitis* 1984; 10:191–192.
50. Eiermann HJ, Larsen W, Maibach HI, et al. Prospective study of cosmetic reactions: 1977–1980. *J Am Acad Dermatol* 1982; 6:909–917.
51. Johansen JD, Menne T. The fragrance mix and its constituents: A 14-year material. *Contact Dermatitis* 1995; 32(1):18–23.
52. Malanin G, Ohela K. Allergic reactions to fragrance-mix and its components. *Contact Dermatitis* 1989; 21:62–63.
53. deGroot AC, VanDerKley AMJ, Bruynzeel DP, et al. Frequency of false-negative reactions to the fragrance mix. *Contact Dermatitis* 1993; 28(3):139–140.
54. Kiec-Swierczynska M, Krecisz B. Allergic contact dermatitis in dentists and dental nurses. *Exog Dermatol* 2002; 1:27–31.
55. deGroot AC, Liem DH, Nater JP, et al. Patch tests with fragrance materials and preservatives. *Contact Dermatitis* 1985; 12:87–92.
56. Buckley DA, Rycroft RJG, White IR, et al. Contact allergy to individual fragrance mix constituents in relation to primary site of dermatitis. *Contact Dermatitis* 2000; 43:304–305.
57. Angelini G, Vena GA, Giglio G, et al. Contact dermatitis due to cosmetics. *J Appl Cosmetol* 1985; 3:223–236.
58. Addo HA, Ferguson J, Johnson BE, et al. The relationship between exposure to fragrance materials and persistent light reaction in the photosensitivity dermatitis with actinic reticuloid syndrome. *Br J Dermatol* 1982; 107:261–274.
59. Gonçalves S, Cabral F, Gonçalves M. Contact sensitivity to oak moss. *Contact Dermatitis* 1988; 19:355–357.
60. Dharmagunawardena B, Takwale A, Sanders KJ, et al. Gas chromatography: an investigative tool in multiple allergies to essential oils. *Contact Dermatitis* 2002; 47:288–292.
61. Schnuch A, Geier J, Frosch PJ. Another look at allergies to fragrances: frequencies of sensitization to the Fragrance Mix and its constituents. *Exog Dermatol* 2002; 1:231–237.
62. Brites MM, Gonçalves M, Figueredo A. Hipersensibilidade à mistura de perfumes da série padrao - avaliação de 10 anos. *Boletim Informativo Grupo Português de estudo das dermatites de contacto* 2000; 14:31–35.
63. Bordalo O, Pereira F, Silva E, et al. Dermite de contacto alérgica a perfumes em cosméticos. *Boletim Informativo Grupo Português de estudo das dermatites de contacto* 1999; 13:22–25.
64. Fregert S, Hjorth N. Results of standard patch tests with substances abandoned. *Contact Dermatitis Newsl* 1969; 5:85.
65. Schnuch A, Lessmann H, Geier J, et al. Contact allergy to fragrances: frequencies of sensitization from 1996 to 2002. Results of the IVDK. *Contact Dermatitis* 2004; 50:65–76.
66. Schnuch A, Uter W, Geier J, et al. Sensitization to 26 fragrances to be labeled according to current European regulation. Results of the IVDK and review of the literature. *Contact Dermatitis* 2007; 57:1–10.
67. Juarez A, Goiriz R, Sanchez-Perez J, et al. Disseminated allergic contact dermatitis after exposure to a topical medication containing geraniol. *Dermatitis* 2008; 19(No 3):163.
68. Nardelli A, D'Hooghe E, Drieghe J, et al. Allergic contact dermatitis from fragrance components in specific topical pharmaceutical products in Belgium. *Contact Dermatitis* 2009; 60:303–313.
69. Megahed M, Holzle E, Plewig G. Persistent light reaction associated with photoallergic contact dermatitis to musk ambrette and allergic contact dermatitis to fragrance mix. *Dermatologica* 1991; 182(3):199–202.
70. Van Joost T, Stolz E, Van Der Hoek JCS, et al. Sensitization to perfume-compounds: clinical and statistical studies. *J Drugther Res* 1984; 9(6):303–305.
71. Paulsen E. Occupational dermatitis in Danish gardeners and greenhouse workers. II. Etiological factors. *Contact Dermatitis* 1998; 38(1):14–19.
72. Shah M, Lewis FM, Gawkrödger DJ. Contact allergy in patients with oral symptoms: a study of 47 patients. *Am J Contact Dermat* 1996; 7(3):146–151.
73. Sugai T. Review article: cosmetic skin diseases in 1994. *Environ Dermatol* 1994; 3:1–7.
74. Vasconcelos C, Barros MA, Mesquita-Guimaraes J. Dermite de contacto alérgica a perfumes. Revisao de 20 casos. *Boletim Informativo Grupo Português de estudo das dermatites de contacto* 2000; 14:36–38.
75. Remaut K. Contact dermatitis due to cosmetic ingredients. *J Appl Cosmetol* 1992; 10(3):73–80.
76. Itoh M, Hosono K, Kantoh H, et al. Patch test results with cosmetic ingredients conducted between 1978 and 1986. *J Soc Cosmet Sci* 1988; 12(1):27–41.
77. Meding B. Skin symptoms among workers in a spice factory. *Contact Dermatitis* 1993; 29(4):202–205.
78. Lapczynski A, Bhatia SP, Foxenberg RJ, et al. Fragrance material review on geraniol. *Food Chem Toxicol (suppl 1)*:S160–S170.
79. Ale SI, Maibach HI. Clinical relevance in allergic contact dermatitis. *Dermatosen* 1995; 43:119–121.
80. Nakada T, Hostynek JJ, Maibach HI. Use tests: ROAT (repeated open application test)/PUT (provocative use test): an overview. *Contact Dermatitis* 2000; 43:1–2.
81. Vey M. Procedures for supplying fragrance information promptly to dermatologists. *Contact Dermatitis* 2003; 48:56–58.

# Survey of alternative and natural drugs in dermatology

Cheryl Levin and Howard I. Maibach

## INTRODUCTION

Supplementation to traditional drugs has gained popularity in recent years, particularly within the field of dermatology where diseases are often chronic and treatments may, at times, be frustrating (1,2). The intent of this review is to survey some of the more recently reported alternative and complementary dermatologic treatments, with an emphasis on those that follow evidence-based dermatology guidelines (3,4). Specifically, this review will highlight treatments for skin pigmentation disorders, psoriasis, atopic dermatitis, aged skin, and oral hairy leukoplakia. This review is intended to update and supplement a previous review of the topic (5).

## SKIN HYPERPIGMENTATION

Skin hyperpigmentation is a concern for which dermatologic care is often sought. Topical hydroquinone is the gold standard treatment. A novel formulation, described by Kligman and Willis in 1975, utilizes hydroquinone in combination with a topical corticosteroid and topical retinoid to provide additional depigmentation (6). However, since 1975, there have been almost no new medical therapies for this common, often frustrating condition.

Assorted plant extracts are potent inhibitors of melanin formation and many have been investigated as potential depigmenting agents. The bioflavonoids as a class, and specifically the flavanones, have been identified as potent tyrosinase inhibitors (7). Flavonones, including hesperidin, eriodictyol, and naringenin, have a chemical structure similar to hydroquinone. In a study by Zhang et al., hesperidin, found in the peel and membranes of citrus fruits, was applied to melanoma B16 cells and human primary melanocytes. A dose-dependent inhibition of tyrosinase activity versus control was observed (8,9). Flavonoids from licorice roots, such as glabrene, glabridin, and isoliquiritigenin, have also been found to inhibit tyrosinase (10). In one study, glabridin applied to cultured B16 murine melanoma cells at concentrations from 0.1 to 1.0  $\mu\text{g}/\text{mL}$  inhibited tyrosinase activity without affecting DNA synthesis (9,11).

The licorice extract liquiritin, another flavonoid, was also found to be effective in decreasing skin pigmentation. In a clinical trial, 2% liquiritin cream at a dose of 1 g/day was applied to 20 women with melasma for four weeks. Eighty percent of the treated cases had a reported excellent response (12). Of note, liquiritin does not inhibit tyrosinase activity. Depigmentation is thought to be secondary to melanin dispersibility and epidermal stain-removing property. Pycnogenol, a flavonoid-containing bark extract, has also decreased pigmentation in melasma patients. In a study of 30 women with melasma, a 25-mg pycnogenol tablet taken three times daily led to a statistically significant decrease in melasma pigmen-

tion, as measured by the average pigment intensity and average melasma area (13).

A recent study by Yamakoshi et al., studied the effects of grape seed extract in treating melasma-associated hyperpigmentation. Twelve Japanese women with melasma took proanthocyanidin-rich grape seed extract three times daily for between six and twelve months, while not using any other treatments for their melasma. There was a significant decrease in their melasma as measured by reflectance spectrophotometry and clinical parameters as compared with baseline (14).

Arbutin, a hydroquinone derivative found in the bearberry plant, has been found to inhibit tyrosinase and 5,6-dihydroxyindole-2-carboxylic acid (DHICA) polymerase activities (15), possibly through competitive inhibition (9). A clinical trial of topical deoxyarbutin (dA, 4-[tetrahydrofuran-2-yl-oxy]-phenol) applied to solar lentigines for 12 weeks led to significant lightening in light-skinned individuals, and minimal lightening in dark-skinned individuals (16).  $\alpha$ -Arbutin (4-hydroxyphenyl  $\alpha$ -glucopyranoside) exhibits greater chemical stability and stronger inhibition of tyrosinase when compared with arbutin (Table 21.1) (17).

## PSORIASIS AND ATOPIC DERMATITIS

Among dermatologic conditions, psoriasis carries significant psychological burden and is associated with widespread treatment dissatisfaction (18,19). As such, patients with psoriasis often turn to alternative therapies to complement their medical treatments. *Aloe vera*, a succulent plant that probably originated in Northern Africa, the Canary islands, and Cape Verde, is a commonly used herbal medicine. Conflicting results have been observed in the treatment of psoriasis. In one study by Syed et al., *A. vera* cream applied three times daily to 60 patients with slight to moderate psoriasis showed improvement as compared with placebo. Improvement was determined by a "positive response," measured as a composite of decreased erythema, infiltration, reductions of lesions, desquamation and lower psoriasis-associated severity index (PASI) score (20). A more recent investigation of *A. vera* gel applied twice daily for four weeks to 41 patients with slight to moderate psoriasis vulgaris showed a greater improvement in placebo-treated patients as compared with those with *A. vera*. Efficacy was measured utilizing a modified PASI score (21).

*Mahonia aquifolium*, an evergreen shrub related to the barberry, has been used in the treatment of atopic dermatitis and psoriasis. In one study, 30 patients with atopic dermatitis were treated with three times daily application of Relieva cream, a homeopathic product containing a proprietary 10% *M. aquifolium* extract. Eczema area and severity index scoring (EASI) revealed significant improvement in both short-term (4-week) and long-term (12-week) improvements as compared

**Table 21.1** Alternative Medications for Hyperpigmentation

Alternative medication	Study type	Experimental result	Source
Hesperidin	In vitro	Inhibits tyrosinase	8
Glabridin	In vitro	Inhibits tyrosinase	11
Liquiritin	In vivo	Decreases melasma pigmentation	12
Pycogenol	In vivo	Decreases melasma pigmentation	13
Grape seed extract	In vivo	Decreases melasma pigmentation	14
Arbutin	In vitro	Decreases tyrosinase and 5,6-dihydroxyindole-2-carboxylic acid	15
Deoxyarbutin	In vivo	Decreases solar lentigines	16

**Table 21.2** Alternative Medications for Psoriasis/Atopic Dermatitis/Pruritus

Alternative medication	Study type	Experimental result	Source
<i>Aloe vera</i>	In vivo	Slight to moderate improvement in psoriasis	20
<i>A. vera</i>	In vivo	No improvement in psoriasis	21
<i>Mahonia aquifolium</i> (Relieva)	In vivo	Improvement of atopic dermatitis	22
<i>M. aquifolium</i> (Relieva)	In vivo	Improvement in psoriasis	24
DSS lotion	In vivo	No improvement in psoriasis	25
DSS soaks (with NB-UVB)	In vivo	No additional improvement in psoriasis as compared with NB-UVB alone	26
Indigo naturalis ointment	In vivo	Improvement in psoriasis	27
Colloidal oatmeal suspension	In vivo	Improvement in pruritus in burn wound-healing patients	31

Abbreviation: DSS, Dead Sea salt.

with baseline (22). However, no placebo control was utilized in this study. In another study on the treatment of psoriasis, 200 patients treated one plaque of psoriasis with Relieva twice daily for 12 weeks. PASI scores were significantly improved in the Relieva-treated patients as compared with placebo (23,24).

The Dead Sea, a salt lake bordering Jordan, the West Bank and Israel, is the deepest hypersaline lake in the world, and with 33.7% salinity, is one of the world's saltiest bodies. It is purported to have several health benefits, and has been investigated in the treatment of psoriasis. In a double-blind, randomized-control clinical trial by Cheesbrough et al., 24 patients were treated with either a 30% Dead Sea salt (DSS) lotion or placebo for a total of 12 weeks. There was no statistically significant improvement in either the DSS lotion or vehicle during the treatment period (25). A more recent study by Dawe et al. investigated DSS soaks plus NB-UVB versus NB-UVB alone in the treatment of plaque psoriasis in a randomized, single-blind, controlled, right/left comparison study. Sixty-six patients pretreated one limb with DSS soaks and then underwent NB-UVB for 12 weeks. There was no significant difference between the DSS soaks plus NB-UVB when compared with NB-UVB alone (Table 21.2) (26).

### Indigo Naturalis

Indigo naturalis, derived from the leaves of plants such as *Baphicacavthus cusia*, has been investigated in the treatment of psoriasis. A recent randomized, observer-blind, vehicle-controlled, inpatient comparison study by Lin et al. evaluated the efficacy of a topical indigo naturalis ointment versus vehicle in the treatment of recalcitrant plaque-type psoriasis in 42 patients. Statistically significant reductions in the sum of scaling, erythema, and induration scores were observed in indigo naturalis treated patients as compared with controls (27). A follow-up study in the Journal of Investigative Science found that the antipsoriatic effects of indigo naturalis involve, at least

partially, modulating the proliferation and differentiation of keratinocytes (28).

### Oatmeal

Oats, a secondary crop, derived from a weed of the primary cereal domesticates wheat and barley (29), are commonly used to treat skin conditions, such as atopic dermatitis. In fact, oatmeal has been deemed an effective skin protectant by the Federal Drug Administration (30). In an assessor-blind study of 35 burn wound-healing patients, 5% colloidal oatmeal in a liquid paraffin suspension applied twice daily was compared with liquid paraffin alone. Patients applying colloidal oatmeal reported significantly less itch and required significantly less antihistamine than those applying vehicle alone (31).

### ANTIOXIDANT

Several botanicals have purported anticarcinogenic properties, including feverfew, rosemary and grape seed extract.

### Feverfew

Feverfew, derived from the Latin *febrifugia*, means "fever reducer." In addition to reduction of fever, it has been used to treat headaches, arthritis, and digestive problems. The active ingredients are parthenolide and tanetin. Parthenolide has been found to be antitumorigenic in vitro and antiproliferative (32,33). Unfortunately, it has also been associated with mouth blisters when taken orally. Therefore, parthenolide has been removed from skin care products, such as *Aveeno*.

### Rosemary

Rosemary is known to exhibit antioxidant properties, which is primarily attributed to the phenolic diterpenes constituent (34,35). Additionally, anticarcinogenesis and, specifically, a



**Table 21.3** Alternative Medications with Antioxidant and Antiwrinkle Potential

Alternative medication	Study type	Experimental result	Source
Feverfew	In vitro	Antitumorigenic Antiproliferative	32,33
Rosemary	In vivo	Antitumorigenic (in mice)	36
Grape seed extract	In vitro	Scavenges free radicals	38
Inner shell of chestnut	In vitro	Prevents skin fibroblast detachment, increases fibronectin, vitronectin	43
Paeoniflorin	In vitro	Protection from NB-UNB-associated damage	44
Paeoniflorin	In vivo	Decreases facial wrinkles	44

decrease in skin tumorigenicity has been observed. In a recent study in mice, the chemopreventive potential of rosemary on DMBA [7,12-dimethylbenz(a)anthracene] initiated and croton oil promoted mouse skin tumorigenesis was assessed. Rosemary leaves extract prolonged the latency period of tumor occurrence, decreased the tumor incidence and tumor burden, and lowered the average weight and diameter of tumors (36,37).

### Grape Seed Extract

The antioxidant properties of grape seed extract are attributed to the oligomeric proanthocyanidins (OPCs), in the flavonoid family. In two separate studies, grape seed extract was shown to more strongly scavenge free radicals as compared with vitamins C and E (38).

Of note, allergic contact dermatitis is commonly observed with use of botanicals. Specifically, rosemary, propolis, and lavender, among others, have been associated with allergic contact dermatitis (39–41).

### ORAL HAIRY LEUKOPLAKIA

Oral hairy leukoplakia is a mucosal disease associated with EBV and commonly observed in patients with HIV infection. It typically presents as a nonpainful white plaque on the lateral border of the tongue. Gentian violet has been evaluated in the treatment of oral hairy leukoplakia. Gentian violet is a known bactericide and antifungal, and is a primary agent used in the Gram stain test. In one case report, 2% gentian violet was applied three times to the tongue in a one-month period. At one-month follow-up, the oral hairy leukoplakia had completely resolved by clinical and histopathologic evaluation. The authors propose that the mechanism of action may be through generation of oxygen species (42). Further investigation is necessary to determine the significance of this case report.

### ANTIWRINKLE COSMECEUTICALS

Fragmented elastic fibers and decreased collagen, along with decreased hyaluronic acid and type IV collagen, are observed in aged skin. Several “natural” products have been evaluated for their antiwrinkle potential. In East Asia, the inner shell of a chestnut is used as an antiwrinkle agent. An in vitro analysis of the chestnut inner shell was evaluated. In this study, the extract prevented cell detachment of skin fibroblasts from culture plates and enhanced expression of fibronectin and vitronectin, extracellular matrix proteins that bind collagen and elastin (43).

In another study by Lee et al., paeoniflorin, a 65% extract from the root of *Paeonia lactiflora* was evaluated for its antiaging

properties in both in vitro and in vivo studies. Paeoniflorin protected cells from UV-induced DNA damage in both cultured normal human keratinocytes (19.4% decrease at 0.001%) and hairless mouse skin keratinocytes (41% decrease at 0.01%). Additionally, an eight-week clinical trial using 0.5% PF-containing formulation with 20 volunteers resulted in a statistically significant reduction in facial wrinkles ( $p < 0.05$ ) (Table 21.3) (44).

### CONCLUSION

The sampling of investigative products presented in this review seems promising. However, caution must be used when translating animal or in vitro studies into clinical application. Further, experimental design, including sample size, drug concentration, and analytic technique greatly influence a study's outcome. The lower cost and wide accessibility of the unconventional remedies has encouraged their continued research. It still remains to be seen, however, which of these products will provide a more advantageous therapeutic ratio when compared with standard agents.

### REFERENCES

- Chen Y, Chang J. Complementary and alternative medicine among patients attending a hospital dermatology clinic in Taiwan. *Int J Dermatol* 2003; 42:616–621.
- Fleisher AJ, Feldman S, Rapp S, et al. Alternative therapies commonly used within a population of patients with psoriasis. *Cutis* 1996; 158:216–220.
- Bigby M. Evidence-based medicine in dermatology. *Dermatol Clin* 2000; 18:261–276.
- Maibach H, Bashir S, McKibbin A. *Evidence Based Dermatology*. Toronto: BC Dekker, 2002.
- Levin C, Maibach H. Exploration of “alternative” and “natural” drugs in Dermatology. *Arch Dermatol* 2002; 138:207–211.
- Kligman AM, Willis I. A new formula for depigmenting human skin. *Arch Dermatol* 1975; 111(1):40–48.
- Tiedtke J, Morel J, Marks O. Depigmentation factor. Bioflavonoids—a safe and effective skin lightener based on encapsulated citrus bioflavonoids. *Cosmetochem* 2004;12–17.
- Zhang R, Zhu W, Xie F. Effect of hesperidin on B16 and HaCaT cell lines irradiated by narrowband-UVB light. *J Clin Dermatol (China)* 2008; 37:146–149.
- Zhu W, Gao J. The use of botanical extracts as topical skin-lightening agents for the improvement of skin pigmentation disorders. *J Invest Dermatol* 2008; 13:20–24.
- Nerya O, Vaya J, Musa R, et al. Glabrene and isoliquiritigenin as tyrosinase inhibitors from licorice roots. *J Agric Food Chem* 2003; 51:1201–1207.
- Fu B, Li H, Wang X, et al. Isolation and identification of flavonoids in licorice and a study of their inhibitory effects on tyrosinase. *J Agric Food Chem* 2005; 53:7408–7414.

12. Amer M, Metwalli M. Topical liquiritin improves melasma. *Int J Dermatol* 2000; 39:299–301.
13. Ni Z, Mu Y, Gulati O. Treatment of melasma with Pycnogenol. *Phytother Res* 2002; 16:567–571.
14. Yamakoshi J, Sano A, Tokutake S, et al. Oral intake of proanthocyanidin-rich extract from grape seeds improves chloasma. *Phytother Res* 2004; 18:895–899.
15. Chakraborty A, Funasaka Y, Komoto M, et al. Effect of arbutin on melanogenic proteins in human melanocytes. *Pigment Cell Res* 1998; 11:206–212.
16. Boissy R, Visscher M, DeLong M. Deoxyarbutine: a novel reversible tyrosinase inhibitor with effective in vivo skin lightening potency. *Exp Dermatol* 2005; 14:601–608.
17. Sugimoto K, Nishimura T, Nomura K, et al. Inhibitory effects of alpha-arbutin on melanin synthesis in cultured human melanoma cells and a three-dimensional human skin model. *Biol Pharm Bull* 2004; 27:510–514.
18. Lebwohl M, Tan M-H. Psoriasis and stress. *Lancet* 1998; 351:82.
19. Stern R, Nijsten T, Feldman S, et al. Psoriasis is common, carries a substantial burden even when not extensive, and is associated with widespread treatment dissatisfaction. *J Invest Dermatol Symp Proc* 2004; 9(2):136–139.
20. Syed T, Ahmad S, Holt A, et al. Management of psoriasis with aloe vera extract in a hydrophilic cream: a placebo-controlled, double-blind study. *Trop Med Int Health* 1996; 1:505–509.
21. Paulsen E, Korsholm L, Brandrup F. A double-blind, placebo-controlled study of a commercial aloe vera gel in the treatment of slight to moderate psoriasis vulgaris. *J Eur Acad Dermatol Venerol* 2005; 19:326–331.
22. Donsky H, Clarke D. Relieva, a *Mahonia aquifolium* extract for the treatment of adult patients with atopic dermatitis. *Am J Ther* 2007; 14:442–446.
23. Smith N, Weymann A, Tausk FA, et al. Complementary and alternative medicine for psoriasis: a qualitative review of the clinical trial literature. *J Am Acad Dermatol* 2009; 61(5):841–856.
24. Bernstein S, Donsky H, Gulliver W, et al. Treatment of mild to moderate psoriasis with Relieva, a *Mahonia aquifolium* extract—a double-blind, placebo-controlled study. *Am J Ther* 2006; 13:121–126.
25. Cheesbrough M. Treatment of psoriasis with 30% Dead Sea salt lotion. *J Dermatol Treat* 1992; 3:201–203.
26. Dawe R, Yule S, Cameron H, et al. A randomized controlled comparison of the efficacy of Dead Sea salt balneophototherapy vs narrowband ultraviolet B monotherapy for chronic plaque psoriasis. *Br J Dermatol* 2005; 153:613–619.
27. Lin YK, Chang CJ, Chang YC, et al. Clinical assessment of patients with recalcitrant psoriasis in a randomized, observer-blind, vehicle-controlled trial using indigo naturalis. *Arch Dermatol* 2008; 144:1457–1464.
28. Lin Y-K, Leu Y-L, Yang S-H, et al. Anti-psoriatic effects of indigo naturalis on the proliferation and differentiation of keratinocytes with indirubin as the active component. *J Dermatol Sci* 2009; 54:168–174.
29. Zhao X, Jellen E, Murphy J. Progenitor germplasm of domesticated hexaploid oat. *Crop Sci* 1999; 39:1208–1214.
30. Baumann LS. Less-known botanical cosmeceuticals. *Dermatol Ther* 2007; 20:330–342.
31. Matheson J, Clayton J, Muller M. The reduction of itch during burn wound healing. *J Burn Care Rehabil* 2001; 22:76–81.
32. Herrera F, Martin V, Rodriguez-Blanco J, et al. Intracellular redox state regulation by parthenolide. *Biochem Biophys Res Commun* 2005; 332:321–325.
33. Sweeney C, Mehrotra S, Sadaria M, et al. The sesquiterpene lactone parthenolide in combination with docetaxel reduces metastasis and improves survival in a xenograft model of breast cancer. *Mol Cancer Ther* 2005; 4:1004–1012.
34. Chiu A, Kimball A. Topical vitamins, minerals and botanical ingredients as modulators of environmental and chronological skin damage. *Br J Dermatol* 2003; 2003(149):681–691.
35. Slamenova D, Kuboskova K, Horvathova E, et al. Rosemary-stimulated reduction of DNA strand breaks and FPG-sensitive sites in mammalian cells treated with H<sub>2</sub>O<sub>2</sub> or visible light-excited methylene blue. *Cancer Lett* 2002; 177:145–153.
36. Sancheti G, Goyal P. Modulatory influence of *Rosmarinus officinalis* on DMBA-induced mouse skin tumorigenesis. *Asian Pac J Cancer Prev* 2006; 7:321–335.
37. Sancheti G, Goyal P. Effect of *Rosmarinus officinalis* in modulating 7,12-dimethylbenz(a)anthracene induced skin tumorigenesis in mice. *Phytother Res* 2006; 20:981–986.
38. Bagschi D, Garg A, Krohn R, et al. Oxygen free radical scavenging abilities of vitamins C and E, and a grape seed proanthocyanidin extract in vitro. *Res Commun Mol Pathol Pharmacol* 1997; 95:179–189.
39. Martínez-González M, Buján JG, Gómez WM, et al. Concomitant allergic contact dermatitis due to *Rosmarinus officinalis* (rosemary) and *Thymus vulgaris* (thyme). *Contact Dermatitis* 2007; 56(1):49–50.
40. Münstedt K, Hellner M, Hackethal A, et al. Contact allergy to propolis in beekeepers. *Allergol Immunopathol (Madr)* 2007; 35:95–100.
41. Goiriz R, Delgado-Jiménez Y, Sánchez-Pérez J, et al. Photoallergic contact dermatitis from lavender oil in topical ketoprofen. *Contact Dermatitis* 2007; 57:381–382.
42. Bhandarkar SS, MacKelfresh J, Fried L, et al. Targeted therapy of oral hairy leukoplakia with gentian violet. *J Am Acad Dermatol* 2008; 58:711–712.
43. Chi Y, Heo M, Chung JH, et al. Effects of the chestnut inner shell extract on the expression of adhesion molecules, fibronectin and vitronectin, of skin fibroblasts in culture. *Arch Pharm Res* 2002; 25:469–474.
44. Lee S, Lim J, Jin MH, et al. Partially purified paeoniflorin exerts protective effects on UV-induced DNA damage and reduces facial wrinkles in human skin. *J Cosmet Sci* 2006; 57:57–64.

# Skin care products for normal, dry, and greasy skin

Céline Try, Laurence Nicod, and Philippe Humbert

## INTRODUCTION

Skin care products have biologically active ingredients with medicinal or druglike benefits. Furthermore, they satisfy the needs of beauty and health. Many substances, either chemically synthesized or extracted from plants or animals, can be used as functional ingredients. Nowadays, many products with biologically active ingredients have been developed and marketed. They are intended to carry out their functions as protection, whitening, tanning, antiwrinkling, deodorants, antiaging, and nail and hair care. Skin care products may however, cause some unwanted problems. The common ones are irritability to the skin, contact dermatitis, photosensitivity, comedogenicity, hair and nail damage, hyper- or hypopigmentation, infectivity, carcinogenicity, and even systemic adverse effects.

Advances in electronics and computing have allowed the development of instruments for measuring certain parameters of the skin. Quantification of these parameters has enabled the evaluation, comparison and hence improvement of the efficacy of skin care products.

## THE DIFFERENT TYPES OF SKIN

### Normal Skin

Normal skin is defined as having no visible lesions or sensations of discomfort. It results from an equilibrium of various continuous biologic processes including keratinization, desquamation, water loss, sebum excretion and sweating. In situations of perfect balance between sebum production and requirements, the skin is comfortable, well moisturized, suppleness, elasticity, clean, easy to decorate and not so easy to irritate.

During aging, the skin undergoes certain changes arising from external causes, in particular ultraviolet (UV) radiation as well as the general aging process that affects the entire organism. According to certain authors, these changes with age are manifested as changes in the chemical structure, the quality and quantity of structural proteins, proteoglycans and hyaluronic acid (1). Also, during adult life, dermal collagen content progressively decreases, correlating with a reduction in skin thickness (2). A simultaneous decrease in the amount of proteoglycans and hyaluronic acid is also seen (1).

Elsewhere, hormonal changes occurring during adolescence and then aging account for the respective increases in sebum secretion seen in puberty, then its progressive decrease during adult life, declining considerably in postmenopausal women (3). With aging, a decrease in the rate of corneocyte desquamation is also seen (4).

### Dry Skin

The term dry skin or xerosis describes an integument with a dry, rough, or scaly appearance with the possible presence of

reddening, cracking, or itching. The skin is less flexible than normal, contributing to the irregular feel to the touch (5,6).

Dry skin results from many factors.

The water content of stratum corneum is reduced (13% of water for normal skin and less of 10% for dry skin)

An abnormal keratinization modifying the stratum corneum equilibrium (between desquamation and proliferation) and corneocytes cohesion (abnormal lipid compartment)

A decrease in barrier function, which increases in the passive rate of transepidermal water loss

Two types of dry skin can be distinguished (7): acquired dry skin and constitutional dry skin. Acquired dry skin may arise from normal, or sometimes even greasy skin, which is rendered temporarily and locally dry by external factors such as solar radiation, exposure to extreme climate (cold, heat, wind, dryness), exposure to chemicals or various therapeutic measures (lithium, retinoids). Constitutional dry skin can be non-pathologic (senile skin, fragile skin) or pathologic (ichthyoses, dry skin of atopic dermatitis, hypothyroidism, uremia).

### Greasy Skin

Greasy skin mainly involves the upper part of the body, where greater numbers of sebaceous gland are found.

The simple greasy skin is common in adolescents and young adults. It is characterized by skin thickening and an increase in sebaceous excretion, giving the face a shiny appearance, especially on the nose and forehead and unclean and smell rancid. In extreme cases, the follicular ducts are often dilated (kerosis). However, they can also plug by minuscule cornified spicules, which protrude and give a sensation of roughness to the touch.

Several parameters induce a production of sebum by sebaceous gland, notably by the main stimulus, circulating androgens levels. In men, the sebum casual level is higher from birth, is temporarily inverted during prepuberty, which occurs earlier in girls. In females, a decrease during the estrogenic phase of the menstrual cycle and an increase during the luteal phase are observed (8).

Several types of complications can be associated with greasy skin, especially the following:

**Acne:** This complication is characterized by the presence of comedones (blackheads) and closed comedones (microcysts). Several causes can be the originate: infection by *Propionibacterium acnes*, which produces free acids by enzymatic hydrolysis of triglycerides; irritation of the dermis by keratin and free fatty acids released by comedones; and immune reactions with sensitization of acne subjects to *P. acnes*.

Seborrheic dermatitis: This is also a frequent problem, which is still unknown but may include *Pityrosporum* yeasts (*Pityrosporum ovale*), chemical agents (detergents), or nervous factors (stress, anxiety). It is characterized by the presence of erythematous squamous plaques, made up of greasy squames, localized mainly on the hairline and eyebrows, nasal folds, chin and presternal region. The scalp is often affected, with the formation of crusty plaques covering the bases of the hair shafts. These lesions are often slightly pruritic.

## METHODS FOR EVALUATING SKIN CHARACTERISTICS (BIOENGINEERING)

The main parameters of different skin types that can be used to evaluate products efficacy are those related to skin surface morphology, *stratum corneum* hydration and sebum excretion. Because of parameter variation between different anatomical zones on the same subject and between different subjects, these techniques are used mainly to measure the change in a parameter with time, on the same zone. For example, a comparison can be made between the initial state (pre-treatment) and the final state (post-treatment).

### Evaluation of Skin Surface Morphology

D-Squames and Corneofix F20 (9,10) are used to detect and assess some damage of the horny layer and alteration of the viable epidermis behavior. The principles of measure consist in a special transparent adhesive tape, which collects corneocytes from the top layer of the skin for five seconds. The tape is removed, stuck on a glass slide, inserted into a microfilm viewer, and its optical density is measured. The latter is inversely proportional to the amount of scales per unit area.

With the probe, precise information regarding desquamation can be obtained: the number, size and thickness of the corneocytes or the roughness of the *stratum corneum* can be evaluated.

## OTHER PROBES

The Visioscan VC98 device (Courage and Khazaka, Köln, Germany) is a video camera that monitors the skin surface illuminated under an UVA light source. Interpretation of the image by the supplied software gives information about skin roughness, smoothness, scaliness, wrinkleless.

Optical coherence tomography (OCT) was originally used for ophthalmologic diagnosis but has found applications in dermatologic investigation (11). OCT is based on the principle of Michelson interferometry and uses a light source with a short coherence length. The light source is split into a reference, and a sample beam being focused on the skin. Structural information on morphology and thickness can be easily obtained, and information on water content or hydration is also available via the calculation of refractive index profiles.

The confocal laser scanning microscopy (Vivascope 1500) (12) enables the instant visualization of skin structures at a histopathologic resolution and represents a new noninvasive approach for the in vivo study of physiologic and pathologic conditions of the skin.

The confocal microscope consists of a small source of light, which illuminates a small spot within the object; the illuminated spots then imaged onto a detector through a small aperture. The source, illuminated spot, and detector

aperture are placed in optically conjugate focal planes. The image are obtained with a defined horizontal layer of 5- $\mu$ m thickness, thus eliminating reflected light from other skin layers as well as aberrations.

A near infrared laser wavelength (830 nm), which is absolutely harmless for user and patient.

## Skin Hydration Measurements

Objective assessment of skin hydration remains the preoccupation of most cosmetic scientists and dermatologists. The methods and techniques used vary in complexity and have been fully described elsewhere (13).

### Measurement of Electrical Properties of the Skin

The dielectric constants of keratin and epidermal lipids are very small as compared with that of water. Therefore, the dielectric constant of the *stratum corneum* is principally determined by its level of hydration: the greater the water content, the larger the dielectric constant.

The Corneometer CM 825 (Courage and Khazaka, Köln, Germany) (14) is an apparatus with a probe that is placed in contact with the skin. The probe acts as a capacitor, in which it is applied. The capacitance thus measured is proportional to the dielectric constant of the skin, varies according to its state of hydration and is expressed in arbitrary units. The device measures capacitance thus measured is proportional to the dielectric constant of the skin, and varies according to its state of hydration. On the forearm the following data are obtained (15):

- <75: dehydrated skin
- 75–90: skin with a tendency to dehydration
- >90: normal skin

Other instruments can evaluate the hydration state of the skin by assessing electrical properties (16):

The DermaLab is manufactured by Cortex Technology (Hadsund, Denmark) and measures the impedance of the skin.

The MoistureMeter SC-4 (Delfin Technology, Kuopio, Finland) is a novel capacitive device. The instrument shows arbitrary capacitance units.

The Nova Dermal Phase Meter DPM 9003 (Nova technology Corporation, Portsmouth, New Hampshire, U.S.) measures impedance-based capacitive reactance of the skin. The final readout is given in arbitrary DPM units, which are related to the capacitance.

The Skicon 200, based on the experimental device developed by Tagami and coworkers, is manufactured by ISBS Company (Hamamatsu, Japan). The instrument measures the conductance in micro siemens.

### Infrared Spectroscopy (17)

Water absorbs infrared radiation. This property has been exploited to quantify, non-invasively *stratum corneum* hydration using attenuated total reflectance infrared spectroscopy. It has been shown that absorbance at 3400/cm characteristic of OH stretching vibrations increases in the deeper layers of the *stratum corneum*, suggesting a corresponding increase in water content as a function of *stratum corneum* depth.

### Measurement of Passive Transepidermal Water Loss (18,19)

Measurement of Transepidermal Water Loss (TEWL) (18,19) determines the continual flux of water vapour diffusing across

the stratum corneum. It does not measure skin hydration, but does allow evaluation of the barrier function and efficacy of hydrating products whose mode of action relies on occlusivity. TEWL is measured using an evaporimeter (Servo Med Evaporimeter, Kinna, Sweden). This device is applied on the skin surface, built as a cylindrical chamber open to the surrounding air and determines the continual flux of water vapor diffusing across the stratum corneum. The process measure the partial water vapor pressure at two points 3 and 9 mm above the skin surface, respectively, with the aid of two pairs of humidity transducers and thermistors.

A normal TEWL values are between 2 and 5 g/m<sup>2</sup>/hr.

#### *Measurement of Wettability (20–25)*

The wettability results from the interactions between a fluid and the skin. A drop of water is placed on the skin and forms with the skin a semi hydrophobic contact angle. The drop is observed with an operating microscope equipped with a slanted mirror, which gives a view of the profile of the drop, recording of the image of the profile using a video camera connected to a computer. The water contact angle  $\theta$  can be measured and it is used as an indicator of hydrophobic or hydrophilic tendency of the skin or to see the effect of products in the greasy or dry skin. For a normal skin,  $\theta$  (forehead) is between 57° and 73°. In the case of dry skin, the affinity with water decreases and the contact angle between skin and water increase.

#### *Evaluation of Friction Coefficient*

Friction is an interaction between two surfaces. Many factors influence the friction coefficient value as hydration or sebum. Hydration studies have correlated increases and decreases in skin hydration with the changes in the friction coefficient (26–28).

### **Sebum Measurement**

#### *Measurement of Sebum Excretion (29,30)*

The Sebumeter SM 810 (Courage and Khazaka, Köln, Germany) uses a plastic tape which is applied on the skin for 30 seconds. The sebum lipids are adsorbed on the film and render it transparent. Next, the probe is inserted into the Sebumeter, which shines a light beam onto the film. A reflective metal plate behind the film reflects the light back, passing a second time through the film, before entering a photomultiplier. The device automatically determines the increase in film transparency as a function of skin surface sebum and gives the lipid index in micrograms per square centimeter.

The Lipometer (L-Oréal, Paris) functions in a similar way to the Sebumeter. Its principal differences are:

The plastic film is replaced by a ground-glass disc mounted on a dynamometer to standardize the application pressure;

A series of standard calibrated values are used to convert readings into absolute data (e.g.,  $\mu\text{g}$  lipid/cm<sup>2</sup>).

#### *Quantification of Sebum Output, Density, and Activity of Sebaceous Glands (31)*

The main component of Sebutape (Cutoderm, Dallas, Texas, U.S.) is a microporous hydrophobic polymer film, which becomes translucent then transparent when impregnated with oil. It can be stuck on the skin as it has an adhesive coating or simply applied (Sebufix F16). The film absorbs the sebum originating

from the follicular openings, which forms transparent spots that are easily visible on a dark background and whose area is proportional to the collected volume. This method quantified the topographical distribution of functional glands and their output on the skin surface using computerized image analysis. The size of the spot is proportional to follicular excretion activity. With sustained application of Sebufix F16, the progressive enlargement of sebum spots can be monitored using a UV light video camera (Visioscan VC98, Courage and Khazaka) and 3-D images obtained at will.

### **Skin Brightness Measurement**

The glossmeter is a new instrumentation to measure the specularly reflecting light from the skin. It can be used to evaluate the skin care including the brightness of the skin. It could be used to evaluate the effect of matting products or hydrating products. Two glossmeters have been developed in 2009: the Glossymeter GL 200 (Courage and Khazaka, Köln, Germany) and the Skinglossmeter (Delphin Technologies, Kuopio, Finland) (32).

## **SKIN CARE PRODUCTS**

### **Care of Normal Skin (33)**

The stratum corneum matrix is rich in ceramides, free fatty acids and cholesterol, which serve to repel water and provide an effective barrier. The integrity of the stratum corneum is also promoted by substances in the corneocytes known as natural moisturizing factor (NMF), a complex mixture of free amino acids, amino acid derivatives and salts, which attract and hold water. This also helps to maintain skin flexibility and elasticity by absorbing water from the atmosphere, which enables the outermost layers of the skin to remain hydrated, despite the drying action of the environment. The fundamental skin care consists of main areas, namely: cleansing, moisturizing and protection.

#### *Cleansing Products*

Washing removes debris from the skin surface, and soap and water are frequently used together for this purpose because of convenience and perceived cost-effectiveness. Soaps are made by hydrolysis of natural triglycerides and neutralization of fatty acids released by sodium. They are good emulsifiers, having emollient action and increased lathering power. However, two problems are associated with them:

Their powerful detergent action may completely eliminate the protective surface lipid film, which helps maintain the skin's physiological balance, and thus may engender irritation.

Soaps have highly alkaline nature (pH  $\approx$  10). The repeated use of soap may shift the pH of the skin surface making it more alkaline, thereby negating the protective influence of the acid mantle, and upsetting the balance of resident flora on the skin (34).

#### *Hydrating Products*

Current emollients are available in the form of sprays, lotions, creams and ointments. Although the development and formulation of emollients has moved forward, the basic principle remains the same, namely they are all variations of an oil (lipid) and water emulsion. Technically these emulsions may

take the form of oil-in-water or water-in-oil emulsions, with oil-in-water emulsions being the most common. Thus, modern emollients can not only help to maintain skin hydration, but can also help to replenish skin barrier lipids as well. The characteristics of emollient are described below in the section Care of Dry Skin.

### Photoprotective Products

Ultraviolet radiation can cause inflammatory changes, erythema, subsequently pigmentation, inducing premature skin aging and a risk of cancer. All long the seasons, photoprotection has an important role for all skin types, including normal skin. The ideal photoprotector must

- effectively absorb noxious radiation (UVB and UVA);
- be substantive to the stratum corneum and be water and sweat resistant;
- be stable in daylight and in air, and to heat and water; and
- be totally innocuous.

A proper sunscreen product must provide protection against acute and long term UV induced skin damage and be stable to heat and UV radiation. The degree to which a sunscreen protects the skin from UV rays is given as its sun protection factor (SPF). The SPF can be used as a guide to select sunscreen to avoid sunburn. The SPF indicates the time a person with sunscreen applied can be exposed to sunlight before getting sunburn relative to the time a person without sunscreen can be exposed.

The photoprotective ability of sun products is determined by two types of substance: chemical filters and physical screens.

Chemical filters (35) are synthetic chemical substances with the following properties:

- Powerful absorption of UV radiation owing to the measure of double bonds
- Relative stability when excited, so the absorbed energy is released slowly

Physical screens are mineral particles that, instead of absorbing UV rays, reflect them like a mirror. The main type used is ultrafine titanium dioxide (TiO<sub>2</sub>), made up of particles of 20–30 nm in size (36). The reduced size of ultrafine particles confers better reflection in the UVB and short UVA wavelengths, and better transparency in the visible wavelengths.

Consumers are more aware of unnatural chemicals and other toxins and are searching for natural products to use on their skin. Antioxidants can have profound effects on the intracellular signaling pathways involved in skin damage and thus may be protective against photodamage as well as may prevent wrinkles and inflammation. The body has physiologic antioxidants, such as vitamins, glutathione, ubiquinon 10 (CoQ10) and  $\alpha$  lipoic acid. The use of exogenous antioxidants can add to the body's physiologic reservoir of endogenous antioxidants and enhance the enzymatic clearance of reactive oxygen species (ROS) (37).

Following, there are many examples of natural components which have antioxidant properties. For some of them, they can be found in skin care.

Vitamins A, C and E are naturally present in human skin. These vitamins are part of a complex system of enzymatic and nonenzymatic antioxidants that protect the skin from harmful

ROS (38,39). However, the skin is subjected to substantial environmental free radical stress from sunlight, pollution, and smoking that can deplete dermal stores of naturally occurring antioxidant. To remedy vitamin deficiency, many topical products can be containing vitamins (40).

Soy contains active ingredients: phytosterols and small protein serine protease inhibitors (Bowman-Birk inhibitor and soybean trypsin inhibitor). Soy has antioxidant and anti-inflammatory effects (41,42). It stimulates collagen synthesis, initiate the skin elastin repair process, inhibit pigmentation and control oil production and moisturizing the skin.

White, green, oolong and black tea are derived from the leaves and buds of the tea plants (*Camellia sinensis*), with the different varieties dependent on the type of processing and oxidation or fermentation. The main active ingredients are polyphenols that include catechin, epicatechin-3-gallate, epigallocatechin and epigallocatechin-3-gallate. These polyphenols have very potent antioxidant, anti-inflammatory, and anticarcinogenic properties, making teas useful in the prevention/treatment of photodamage (43,44).

Pomegranate extract (*Punica granatum*) is primarily composed of alkaloids and polyphenols, the active constituent being ellagic acid and has demonstrated a variety of beneficial functions including antioxidative and antiviral activity. Pomegranate seed oil fractions may facilitate epidermal regeneration (30).

Ectoin, a natural, vital substance was developed for the use in cosmetic applications. It was discovered in halophilic bacteria, which survive and grow under extreme conditions in salt lakes, sea water and saline deserts. Efficacy studies in vitro demonstrated that Ectoin counteracts the effects of UVA-induced and UVA-accelerated skin ageing at different cell levels. In fact, ectoin protects the skin from effects of UVA-induced cell damage in a number of different ways and has the potential to protect mitochondria of human fibroblasts in vitro against UVA radiation-induced mutagenesis (45).

Sesamol (46) is a highly acclaimed antioxidant. An experiment on mouse skin showed that it has a good effect on prevention on photodamage, observed on biochemical and histopathologic changes.

### Care of Dry Skin (47–49)

Treatment of dry skin is aimed at restoration of the epidermal water barrier. This is accomplished with moisturizing agents that are topically applied to the skin.

Excessive bathing or the use of hot baths or showers should be discouraged and the use of mild soaps rather than harsh soaps or detergents should be encouraged.

Soap substitutes such as cetyl alcohol preparations can be helpful in dry skin. Hydration of the stratum corneum by balneotherapy followed by either addition of oil to the bath water or rapid application of emollients (occlusive agents) to the skin on exit from the bath can improve hydration of the stratum corneum.

Hydration can be done in two ways.

By the input of external water, which is retained in the stratum corneum by addition of humectants

By the slowing down of stratum corneum water loss due to evaporation (reducing TEWL), by means of an occlusive lipid film

The lipids in the latter can combat the delipidization associated with dry skin, and protect against external agents. Formulation of a hydrating product involves both of these principles, but with different emphasis placed on them depending on the type of skin and conditions of use envisaged.

#### *Humectant Moisturizing Ingredients*

Humectants are compounds that attract water from the dermis into the stratum corneum. They are many and varied. When humidity is higher than 70%, humectants can also attract water from the atmosphere into the epidermis. Humectants can be thought of as the cosmetic equivalents of NMF. NMFs are natural components including hygroscopic and hydrosoluble substances in the stratum corneum which are most likely to be enveloped by cell membrane lipids. These substances play an important role in water retention, since it has been shown that their extraction results in a 25% loss in stratum corneum water content and 66% loss in elasticity (50). NMF agents include the following:

Polyols are molecules with numerous hydroxyl groups (hydrophilic and hygroscopic substances). Glycerol and sorbitol are excellent humectants and are used at concentration between 2% and 10%. Propylene glycol has good hydrating ability at low concentrations (inferior to 10%) and keratolytic activity at high concentrations (superior to 40%). Other polyols are used like mannitol but there are less hydrating.

Pyrrolidone carboxylic acid is the one of principal components of NMF (about 12%). It is found in salt form and has a hydrating effect at concentration of 3% to 5%.

Urea hydrates at concentration at less than 10%. Over this concentration, urea has keratolytic power. This molecule have a highly solubility in water and is rapidly hydrolyzed and decomposed.

Lactic acid and sodium lactate can capture a high concentration of water. It has an effect from concentration of 3%.

Certain macromolecules of biologic origin have a high content of hydrophilic groups, but with their high size, they cannot penetrate the stratum corneum and they form at the surface, a hygroscopic film.

Certain macromolecules of biologic origin have a high content of hydrophilic groups, but with their high size, they cannot penetrate the stratum corneum and they form at the surface, a hygroscopic film. This category includes the following:

Glycosaminoglycans such as hyaluronic acid and chondroitin sulphate are polysaccharides. These compounds are found in the ground substance of all connective tissue and possess a considerable water sorption and retention, owing the large number of hydroxyl groups. Collagen and elastin are the two main structural protein of the connective tissue and have hygroscopic property. With water, they form an aqueous gel. These proteins are generally used in denatured or hydrolysed form.

DNA has a large number of phosphate groups and possesses a good hygroscopic property. It used in a denatured and partially hydrolyzed form in cosmetology.

#### *Occlusive Moisturizing Ingredients (48)*

Occlusives increase the water content of the skin by slowing the evaporation of water from the surface of the skin. These ingredients are often greasy and are most effective when applied to damp skin. Mineral oil is often used because of its

favorable texture, but it is not as effective at preventing evaporation of water as many other occlusives.

Actually, filmogenic products compose the emulsion. Water-in-oil emulsion is very occlusive. Petrolatum, an hydrocarbon oil, is the most effective occlusive moisturizer.

Other hydrocarbons include mineral oil, paraffin, and squalene. In occlusive moisturizing ingredients, other categories of compounds exist and include vegetable fats, fatty alcohols, wax esters, vegetable waxes, phospholipids, sterols, silicones and oils rich in polyunsaturated fatty acids (PUFAs).

Oils rich in PUFAs (49) occupy a particular place in cosmetology. They are occlusive but their potential lies in their high PUFA content. PUFAs are long-chain fatty acids, unsaturated at  $\omega$ -3 or  $\omega$ -6, of which some are classed among the essential fatty acids (linoleic acid, arachidonic acid, linolenic acid). These PUFAs are found in large quantities in certain animal oils (fish oil) and plants (evening primrose, borage, grape seed). They are involved in several important physiologic functions such as metabolism of prostaglandins and leukotrienes, inflammation and hence the maintenance of stratum corneum hydration.

#### *Additives to Moisturizer*

Other agents are now included in moisturization products. These agents have different functions than simply reducing TEWL or reconstituting the lipid components of the stratum corneum. Special moisturizing agents such as  $\alpha$ - or  $\beta$ -hydroxy acids can help promote corneocyte desquamation and decrease roughness.

$\alpha$ -Hydroxy acids (49) (lactic, glycolic, malic, tartaric, citric, gluconic, and mandelic acids) have been shown to improve the appearance of photodamaged skin and are an effective keratolytic in concentration as low as 10%, and have a tendency to reduce corneocytes cohesion at the base of stratum corneum. At high concentration (30–70%), their keratolytic action predominates: they act on the deeper epidermal layers, and even the papillary and reticular dermis. At these concentrations they are suggested for the treatment of hyperkeratosis.

Salicylic acid is the only  $\beta$ -hydroxy acid. Its mechanism of action is supposed on the dissolution of the intercellular cement between adjacent corneocytes, reducing corneocytes adhesion. It is unique in that it can enter the pilosebaceous unit and increase exfoliation in the oily areas of the face. Because of its exfoliating effects, salicylic acid is beneficial in aging skin because of increased desquamation of the stratum corneum.

Urea (48) can also be added to moisturizers and enhances the water-binding capacity of the stratum corneum by disrupting hydrogen bonding. Urea exposes water-binding sites on corneocytes and promotes desquamation by decreasing the intercellular cementing substance between the corneocytes. Also, long-term treatment with urea has been demonstrated to decrease TEWL.

#### **Care of Greasy Skin (51)**

The essential requirement is to reduce excess skin surface sebum without total delipidization. Severe degreasing treatment can lead to an exacerbation of sebaceous secretion.

Facial washing may be carried out with either an oily soap. This must be followed by copious rinsing. In cold weather, the protection afforded by a continuous aqueous phase, light emulsion (oil in water) suffices. However, products used for this type of skin must be noncomedogenic.

## Acne Treatment

### Comedolytic Agents

Salicylic acid, lactic acid, glycolic acid, and benzoyl peroxide may all decrease follicular impaction and have been proved in both human and animal use. Of these compounds, salicylic acid is the most widely used. It has been shown to be safe and effective in reducing comedones when applied in 0.5% and 2% solutions.

The use of topical benzoyl peroxide does have some limitations. It is not effective as a monotherapy for severe acne. Leave on benzoyl peroxide creams and gel have the potential to bleach clothes and bed linens, like all topical medications, have the risk of causing an allergic contact dermatitis.

Some more recent innovations in benzoyl peroxide formulations include microsphere technology, aqueous-based gel, liposomal delivery and microemulsion. The latest innovation involves the use of micronization to produce solubilized benzoyl peroxide particles, which allows the smaller-sized particles to penetrate down into the follicle.

Moreover, irritation associated with benzoyl peroxide can be minimized, while maintaining equal efficacy, by using the 2.5% formulation of benzoyl peroxide and vehicle such as the dimethyl isorobide containing hydrophase base and the 10% urea (52).

As benzoyl peroxide treatment technology advances, it should become even more useful of a treatment, as monotherapy or adjunct, for mild to moderate acne vulgaris.

### Topical Antibiotics

The use of topical antibiotics (macrolide as clindamycin or erythromycin) is frequently. Its bactericidal action on *P. acnes* results to inhibit bacterial protein synthesis.

The problem of emergence of antibiotic resistant *P. acnes* encountered with topical clindamycin monotherapy is markedly reduced by the addition of benzoyl peroxide as a combination formulation. Fixed combination products of clindamycin 1% and benzoyl peroxide 5% are commonly used in the treatment of acne vulgaris. Although any given topical acne product may be therapeutically effective, signs and symptoms of cutaneous tolerability may lead to missed applications by the patient, thus limiting adherence to therapy. Benzoyl peroxide can cause cutaneous irritation and dryness, which are dose-dependant. Recently, clindamycin and benzoyl peroxide 2.5% gel appears to provide efficacy comparable to that of higher concentration (5%) fixed clindamycin-benzoyl peroxide combination products and should optimize patient compliance as a result of the reduction in cutaneous tolerability reactions, including signs of skin irritation or dryness (53).

### Azelaic Acid

It is a naturally occurring dicarboxylic acid produced by yeasts of the *Pityrosporum* genus. It is a compound with significant direct anti-*P. acnes* activity and some comedonal activity. The compound has no effect on sebaceous gland size, sebum production or sebum composition, even after long-term application. Azelaic acid is bacteriostatic at low concentrations and bactericidal at higher levels.

### Topical Tretinoin

Tretinoin, which is the acid form of vitamin A and also known as all-*trans* retinoic acid, works both by comedolysis and by normalizing the maturation of follicular epithelium so that

comedons formation ceases. It has no antiseborrheic or bactericidal activity.

All concentrations of tretinoin are useful in comedonal and inflammatory acne (0.05% or 0.1% cream is the maximal benefit).

Despite its benefits, tretinoin, as with other topical retinoids, has the potential to cause localized irritation. To minimize this response while maintaining clinical efficacy, tretinoin has been formulated in sponge like polymeric microspheres that encapsulate the active ingredient and deliver gradually and relatively selectively to the follicle. In comparison with a standard 0.025% cream, a tretinoin microsphere gel 0.1% formulation has been shown to be less irritant to normal skin and to cause significantly less erythema and dryness in patient with mild to moderate facial acne over a period of 12 weeks (54,55).

## Sebum Regulator

### Intradermal Botulinum Toxin

The use of intradermal botulinum toxin type A is a new technique. The purported mechanism of action of botulinum pore reduction can be postulated on the basis of its known neuromodulatory effects. A. Shah shows that intradermal botulinum toxin can be injected safely in the area of the forehead, medial cheek, and nose without complications. A treatment of intradermal botulinum toxin subjectively reduced skin oiliness and pore size in 17/20 patients at 1 month after injection (56).

The role of botulinum toxin in targeted therapy without systemic consequences may eventually make it an alternative to isotretinoin in the treatment of oily skin and acne prone skin.

## Seborrheic Dermatitis Treatment

Essentially, this consists of daily treatment with topical antifungals (topical imidazoles), which act on *Pityrosporum*.

Treatments using products with 5- $\alpha$  reductase inhibitors (acetamide and unsaponifiable plant oils) may also be used to combat seborrhoea.

In parallel, treatments for greasy skin will also be used.

## CONCLUSION

In recent years, considerable progress has been made in cosmetics, which was originally mainly concerned with perfume and make-up. Nowadays, the emphasis is much more on the development of veritable medical cosmetics of increasingly high performance, specifically adapted for all kinds of skin types, and backed up by rigorous scientific testing procedures for efficacy and tolerance. Whether one considers the various protective roles of all these products, or looks more specifically at, say, the corrective properties of treatment for dry or greasy skin, all have the common aim of maintaining or restoring the skin to its 'normal' state. At the same time, these products can also be used as complementary treatments for more classical therapy, particularly where side effects occur.

## REFERENCES

1. Pierard GE, Lapiere CM. Structures et fonction du derme et de l'hypoderme. In: Prunieras M, ed. Précis de Cosmétologie Dermatologique. Paris: Masson, 1989:37-50.
2. Shuster S, Black MM, McVitie E. The influence of age and sex on skin thickness, skin collagen and density. Br J Dermatol 1975; 93:639-643.



3. Agache P. Seborrhea. In: Zviak C, ed. *The Science of Hair Care*. New York: Marcel Dekker, 1986:469–499.
4. Roberts D, Marks R. The determination of regional and age variations in the rate of desquamation: a comparison of four techniques. *J Invest Dermatol* 1980; 74:13–16.
5. Chernosky ME. Clinical aspects of dry skin. *J Soc Cosmet Chem* 1976; 27:24–28.
6. Seitz JC, Rizer RL, Spencer TS. Photographic standardization of dry skin. *J Soc Cosmet Chem* 1984; 35:423–437.
7. Curtil L. Améliorer les peaux sèches. *Rev Eur Dermatol MST* 1992; 4:75–82.
8. Agache P. Sebaceous physiology. In: Agache P, Humbert PH, eds. *Measuring the Skin*. Berlin: Springer, 2004:271–280.
9. Agache P. Metrology of the stratum corneum. In: Agache P, Humbert PH, eds. *Measuring the Skin*. Berlin: Springer, 2004:101–111.
10. Schatz H, Kligman AM, Manning S, et al. Quantification of dry (xerotic) skin by image analysis of scales removed by adhesive discs (D-Squames). *J Soc Cosmet Chem* 1993; 44:53–63.
11. Welzel J. Optical coherence tomography in dermatology. *J Biomed Optics* 2000; 5:83–92.
12. Corcuff P, Gonnard G, Pierard GE, et al. In vivo confocal microscopy scanning laser microscopy: a new design for cosmetology and dermatology. *Scanning* 1996; 18:351–355.
13. Elsner P, Berardesca E, Maibach HI, eds. *Bioengineering of the Skin: Water and the Stratum Corneum*. Boca Raton, FL: CRC Press, 1994.
14. Courage W. Hardware and measuring principle: corneometer. In: Elsner P, Berardesca E, Maibach HI, eds. *Bioengineering of the Skin: Water and the Stratum Corneum*. Boca Raton, FL: CRC Press, 1994:171–175.
15. Marty JP, Vincent CM, Fiquet E. Etude des propriétés hydratantes de la crème hydratante visage Neutrogena. *Réalités Ther Dermatovenerol* 1992; 15:37–40.
16. Gabard B, Clarys P, Barel AO. Comparison of commercial electrical measurement instruments for assessing the hydration state of the stratum corneum. In: Serup J, Jemec G, Grove G, eds. *Handbook of Non-Invasive Methods and the Skin*. 2nd ed. Boca Raton: CRC Press, 2006.
17. Triebkorn A, Gloor M. Infrared spectroscopy. A method for measurement of moisture in the stratum corneum using the ATR method. In: 16èmes Journées Internationales de Dermocosmétologie de Lyon, 18–20 mai 1988:47–55.
18. Wilson DR, Maibach HI. Transepidermal water loss: a review. In: Lévêque JL, ed. *Cutaneous Investigation in Health and Disease*. New York: Marcel Dekker, 1989:113–133.
19. Gabard B, Treffel P. Transepidermal water loss. In: Agache P, Humbert PH, eds. *Measuring the Skin*. Berlin: Springer, 2004:553–564.
20. Agache P, Elkhyat A, Mavon A. Measurement of skin surface wettability. In: Agache P, Humbert PH, eds. *Measuring the Skin*. Berlin: Springer, 2004:87–94.
21. Mavon A, Zahouani H, Redoules D, et al. Sebum and stratum corneum lipids increase human skin surface free energy as determined from contact angle measurements: a study on two anatomical sites. *Coll Surf B Biointerface* 1997; 8:147–155.
22. Elkhyat A, Courderot-Masuyer C, Mac-Mary S, et al. Assessment of spray application of Saint Gervais water effects on skin wettability by contact angle measurement comparison with bidistilled water. *Skin Res Technol* 2004; 10:283–286.
23. Elkhyat A, Courderot-Masuyer C, Gharbi T, et al. Influence of the hydrophobic and hydrophilic characteristics of sliding and slider surfaces on friction coefficient: *in vivo* human skin friction human skin friction comparison. *Skin Res Technol* 2004; 10:215–221.
24. Elkhyat A, Mac-Mary S, Humbert PH. Skin wettability and friction. In: Barel AO, Paye M, Maibach HI, eds. *Handbook of Cosmetic Science and Technology*. 3rd ed. New York: Taylor & Francis, 2009:427–436.
25. Mavon A, Redoules D, Humbert PH, et al. Changes in sebum levels and skin surface free energy components following skin surface washing. *Coll Surf B Biointerface* 1998; 10:243–250.
26. Sivamani RK, Wu G, Maibach HI. Tribological studies on skin: measurement of the coefficient of friction. In: Barel AO, Paye M, Maibach HI, eds. *Handbook of Cosmetic Science and Technology*, 3rd ed. New York: Taylor & Francis, 2009:415–425.
27. Cua AB, Wilhelm KP, Maibach HI. Frictional properties of human skin: relation to age, sex and anatomical region, stratum corneum hydration and transepidermal water loss. *Br J Dermatol* 1990; 123:473–479.
28. Elkhyat A, Courderot-Masuyer C, Gharbi T, et al. Influence of the hydrophobic and hydrophilic characteristics of sliding and slider surfaces on friction coefficient: *in vivo* human skin friction comparison. *Skin Res Technol* 2004; 10:215–221.
29. Agache P. Sebaceous function assessment. In: Agache P, Humbert PH, eds. *Measuring the Skin*. Berlin: Springer, 2004:281–289.
30. Agache P. Evaluation de la production sébacée. In: Thivolet J, Schmitt D, eds. *Biologie de la peau. Séminaire INSERM*. Vol 148, 1987:93–100.
31. Pierard GE, Pierard-Franchimont C, Lê T, et al. Patterns of follicular sebum excretion rate during lifetime. *Arch Dermatol Res* 1987; 279:S104–S107.
32. Petitjean A, Sainthillier JM, Mac-Mary S, et al. Skin radiance: how to quantify? Validation of an optical method. *Skin Res Technol* 2007; 13(1):2–8.
33. Curtil L, Richard A. Maintenir en bon état les peaux normales. *Rev Eur Dermatol MST* 1991; 3:403–410.
34. Korting HC, Kober M, Mueller M, et al. Influence of repeated washings with soap and synthetic detergents on pH and resident flora of forehead and forearm. *Acta Derm Venereol (Stockh)* 1987; 67:41–47.
35. Jeanmougin M. Filtres et écrans solaires. *Bull Esthet Dermatol Cosmetol* 1983; 7:11–21.
36. Msika PH, Boyer F. Efficacité et sécurité de l'oxyde de titane ultrafin en photoprotection. *Bull Esthet Dermatol Cosmetol* 1993; 1:231–240.
37. Ditre C, Wu J, Baumann LS, et al. Innovations in natural antioxidants and their role in dermatology. *Cutis* 2008; 82(6 suppl):2–16.
38. Thiele JJ, Hsieh SN, Ekanayake Mudiyansele S. Vitamin E: critical review of its current use in cosmetic and clinical dermatology. *Dermatol Surg* 2005; 31:805–813.
39. Farris PK. Topical vitamin C: a useful agent for treating photoaging and other dermatologic conditions. *Dermatol Surg* 2005; 31:814–818.
40. Burke KE. Photodamage of the skin: protection and reversal with topical antioxidants. *J Cosmet Dermatol* 2004; 3:149–155.
41. Wallo W, Nebus J, Leyeden JJ. Efficacy of a soy moisturizer in photoaging: a double-blind, vehicle controlled, 12-weeks study. *J Drugs Dermatol* 2007; 6:917–922.
42. Bonina F, Puglia C, Avogadro M, et al. The topical protective effect of soybean germ oil against UVB-induced cutaneous erythema: an *in vivo* evaluation. *Arch Pharm* 2005; 338:598–601.
43. Camouse MM, Hannelan KK, Conrad EP, et al. Protective effects of tea polyphenols and caffeine. *Expert Rev Anticancer Ther* 2005; 5:1061–1068.
44. Katiyar S, Elmets CA, Katiyar SK. Green tea and skin cancer: photoimmunology, angiogenesis and DNA repair. *J Nutr Biochem* 2007; 18:287–296.
45. Heinrich U, Barbe B, Tronnier H. *In vivo* assessment of ectoin: a randomized, vehicle-controlled clinical trial. *Skin Pharmacol Physiol* 2007; 20(4):211–218.
46. Sharma S, Kaur IP. Development and evaluation of sesamol as an antiaging agent. *Int J Dermatol* 2006; 45:200–208.
47. Proksch E. Protection against dryness of facial skin: a rational approach. *Skin Pharmacol Physiol* 2009; 22:3–7.
48. Curtil L. Améliorer les peaux sèches. *Rev Eur Dermatol MST* 1991; 3:457–464.

49. Gougerot A, Enjolras O. Améliorer les peaux sèches pathologiques. *Rev Eur Dermatol MST* 1992; 4:75–82.
50. Ramette G. Produits cosmétiques de protection et de correction. In: Prunieras M, ed. *Précis de cosmétologie dermatologique*. Paris: Masson, 1981:103–122.
51. Roger F. Les cosmétiques de la peau grasse. *Bull Esthet Dermatol Cosmetol* 1985; 5:13–18.
52. Fakhouri T, Yentzer BA, Feldman SR. Advancement in benzoyl peroxide-based acne treatment: methods to increase both efficacy and tolerability. *J Drugs Dermatol* 2009; 8:657–661.
53. Bucks D, Sarpotdar P, Yu K, et al. The development and optimization of a fixed combination of clindamycin and benzoyl peroxide aqueous gel. *J Drugs Dermatol* 2009; 8:634–638.
54. Nighland M, Grossman R. Tretinoin microsphere gel in facial acne vulgaris: a meta-analysis. *J Drugs Dermatol* 2008; 7(8 suppl):2–8.
55. Jorizzo J, Grossman R, Nighland M. Tretinoin microsphere gel in younger acne patient. *J Drugs Dermatol* 2008; 7(8 suppl):9–13.
56. Shah AR. Use of intradermal botulinum toxin to reduce sebum production and facial pore size. *J Drugs Dermatol* 2008; 7:847–850.

## Self-tanning products

Stanley B. Levy

### INTRODUCTION

With improvements in formulation and aesthetics, sunless or self-tanning products have become a viable alternative to UV tanning. Public awareness as to the hazards of both natural and artificial UV tanning has facilitated self-tanners becoming a significant component of the overall sun care market. Over 20% of young adults in both the United States and Australia reported using these products in a recent year (1,2). Individual users were more likely to have had sunburns consistent with higher use of these products in Caucasians. In other studies, exclusive users of sunless tanners were more likely to practice overall sun protection (3,4) and decrease their use of ultraviolet light tanning beds (5).

Dihydroxyacetone (DHA), a keto sugar, is the active ingredient in sunless or self-tanners and is responsible for darkening the skin by staining. DHA is classified in the International Cosmetic Ingredient Dictionary and Handbook (6) as a colorant or a colorless dye. Other similar sugars such as erythrulose and glyceraldehyde are occasionally used. Products containing DHA should not be confused with bronzers intended to produce a darker color on the skin by the use of water-soluble colorants or dyes. Other agents that have been used to enhance skin pigmentation with and without stimulation by UV with varying degrees of success and toxicity (Table 23.1) will not be discussed in detail here (7).

### CHEMISTRY

Dihydroxyacetone ( $C_3H_6O_3$ ) is a white crystalline hygroscopic powder. This three-carbon sugar forms a dimer in freshly prepared aqueous solution (Fig. 23.1). With heating to affect a solution in alcohol, ether, or acetone, it reverts to the monomer. The monomeric form is less stable, but is more important in the browning reaction that leads to the skin color change (8). DHA is stable between pH 4 to 6, but above pH 7 efficacy is lost with the formation of brown colored compounds. A buffered mixture at pH 5 is most stable. Heating above  $38^\circ C$  for long periods of time will also affect stability. DHA needs to be stored in a cool, dry place, ideally  $4^\circ C$  and low atmospheric humidity (9). Glyceraldehyde, the isomer of DHA, is also present in solution. Glyceraldehyde may degrade into formaldehyde and formic acid. In acidic solution (pH 4), this isomerization and therefore these latter undesirable ingredients are minimized. Commercially available formulations generally contain 2.5% to 10% DHA (Fig. 23.2).

The Maillard or browning reaction has been defined as the reaction of an amino group of amino acids, peptides, or proteins with the glycosidic hydroxyl group of sugars. DHA in the context of this reaction may be considered a three-carbon sugar, reacting with free amino groups available as amino acids, peptides, and proteins supplied by the keratin to form

products or chromophores referred to as melanoidins (10). Melanoidins have some physicochemical properties similar to naturally occurring melanin (11). Electron spin resonance has recently shown that free radicals are produced in vivo by the Maillard reaction (12).

### MECHANISM OF ACTION

The site of action of DHA is the stratum corneum (13). Tape stripping of the skin quickly removes the color (14), as does mechanical rubbing. Deeper staining in areas with thicker stratum corneum and no staining of mucous membranes without a stratum corneum are also consistent with this being the site of action. DHA may be used as a substitute for dansyl chloride as a measure of stratum corneum turnover time (15,16). Microscopic studies of stripped stratum corneum and hair reveal irregular pigment masses in the keratin layers (17) consistent with melanoidins. These melanoidins are formed via the Maillard reaction with DHA as a sugar reacting with the amino groups supplied by the keratin.

### APPLICATION

Following application of a typical DHA containing self-tanning lotion, color change may be observed within an hour (18). This color change may be seen under Wood's light (black light) within 20 minutes. Maximal darkening may take 8 to 24 hours to develop. Individuals can make several successive applications every few hours to achieve their desired color. Color may last as long as five to seven days with a single application. Depending on anatomical application, the same color can be maintained with repeat applications every one to four days. The face requires fewer applications but more frequent reapplication to maintain the color than the extremities. Depth of color varies with the thickness and compactness of the stratum corneum. Palms and soles stain deepest, necessitating washing of hands after application to avoid staining. Hair and nails will color but not mucous membranes lacking a stratum corneum or keratin layer. Rougher hyperkeratotic skin over the knees, elbows, and ankles will color more unevenly as will older skin with keratoses and mottled pigmentation. Color will also be maintained longer in these areas.

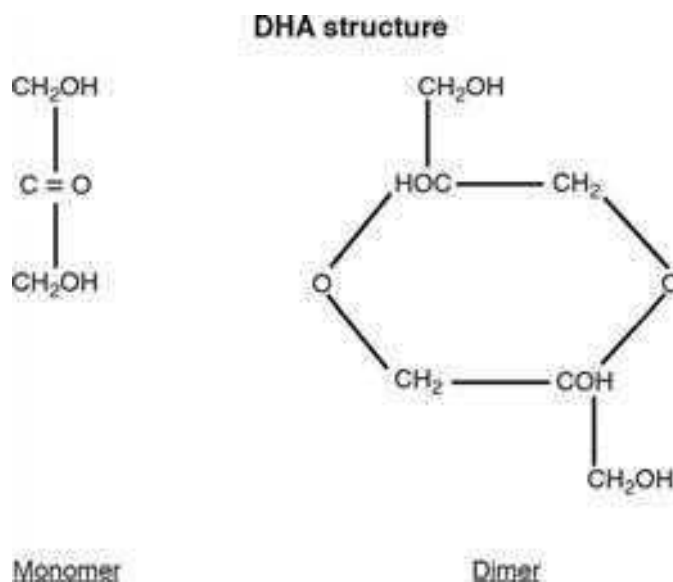
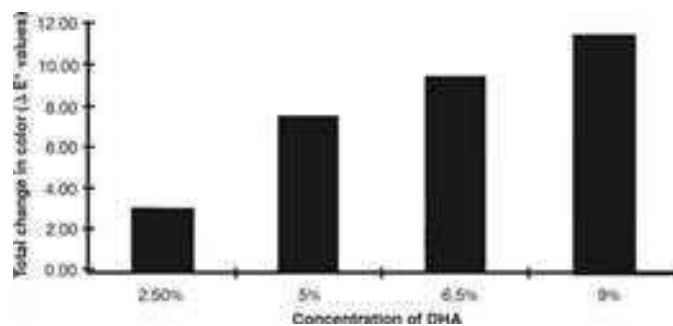
As in the formulation, the pH of the skin before application may have an effect on the tonality of the skin color (10). Alkaline residues from soaps or detergents may interfere with the reaction between DHA and the amino acids on the skin surface, resulting in a less natural (more yellow) appearing color. Wiping the skin surface with a hydroalcoholic acidic toner just prior to DHA application may improve results. Ex vivo epidermal studies suggest that skin hydration (19) and relative humidity (20) influence the development of coloration.

**Table 23.1** Tanning Product Types

Product type	Active ingredient
Sunless or self-tanner	Dihydroxyacetone
Bronzer	Dyes
Tanning simulator	Melanins
Tanning preparation	UVB sunscreens
Tan accelerator	Tyrosine
Tanning promoter	5-Methoxypsoralen
Tanning pill	Canthaxanthin
Hormone	Synthetic analogues $\alpha$ -MSH

**Table 23.2** Application Instructions for Self-Tanners

Prepare skin with mechanical exfoliation
Spot test
Wipe skin with hydroalcoholic acidic toner
Apply carefully and evenly
Apply less to thicker skin
Allow to dry
Reapply regularly
Remember sun protection

**Figure 23.1** Chemical structure of DHA.**Figure 23.2** Degree of skin darkening with concentrations of DHA.

Careful application is key with using these products (Table 23.2). The skin may be prepared with a mild form of exfoliation. Even application is required with lighter application around elbows, knees, and ankles to avoid excessive darkening in these areas. Care also needs to be taken around the hairline where lighter hair may darken. Hands need to be washed immediately after use to avoid darkening of the palms,

fingers, and nails. Skill and experience are necessary with using these products resulting in greater user satisfaction.

Spray-on tanning formulations may aid in providing an even application (21). Larger air operator assisted delivery units are available for air-brushing on by a technician. Tanning booths using sprays are now commonplace in spas and salons. This form of application introduces the potential hazard of inhalation of sprayed material.

Some formulations include colorants as used in bronzers, including dyes and caramel, to achieve an immediate makeup effect. Tinting with iron oxides or titanium dioxide can provide immediate color and allow the user to visualize evenness of application. Metal oxides may however induce degradation of DHA (22). Vitamins, botanical extracts, antioxidants, anti-irritants, and even  $\alpha$ -hydroxy acids may be added to broaden the manufacturer's claims made with a given product. The addition of sunscreen ingredients to self-tanners warrants a more detailed discussion in the section that follows.

### SUNSCREEN ACTIVITY

DHA itself has at most a modest effect on SPF (23), providing perhaps SPF 3 or 4 protection. SPF increases with DHA concentration and number of applications (24). Low-level SPF persists for several days decreasing with loss of color (25). The brown color obtained on the skin does absorb in the low end of the visible spectrum with overlap into long UVA and may provide some UVA I protection (26). Melanoidins can act as free-radical scavengers as they demonstrate an electron spin resonance signal (12). Superficial skin coloration induced by frequent topical application of DHA in high concentrations may delay skin cancer development in hairless mice irradiated with moderate UV doses (27).

Individuals using DHA-containing tanning products need to be cautioned that despite visible darkening of their skin, these products provide minimal sun protection. Confusion may be compounded by the addition of UV filters to the formulation providing significant sun protection. The stated SPF for the product is applicable for a few hours after application, but not for the days during which the skin color change may remain perceptible.

### INDICATIONS

Even with recent improvement in DHA formulations, the color achieved remains dependent on skin type. Individuals of medium complexion with skin phototypes II or III (28), as opposed to those who are lighter or darker will obtain a more pleasing color. Individuals with underlying golden skin tones will achieve better results than individuals with rosy, sallow, or olive complexion. Older consumers with roughened,

hyperkeratotic skin or mottled pigmentation with freckling may be less pleased with their use.

Dermatologists regularly recommend these products for tanning as a safe alternative to UV exposure. They may be used to camouflage some skin irregularities such as leg spider veins. Light to medium complexioned patients with vitiligo who show increased contrast with the vitiliginous areas with natural or unavoidable tanning in their normal skin may also benefit (29,30). They may even provide some protection for individuals with certain photosensitivity disorders (31). Protection of uninvolved skin by DHA during psoralen-UVA treatment (PUVA) allows higher UVA exposures to be tolerated, with fewer treatments resulting in faster clearing known as Turbo-PUVA (32).

## SAFETY

The visible color change associated with the use of artificial tanning products might suggest to some users that these products are hazardous. On the basis of the chemistry of DHA and its toxicological profile, it can be considered nontoxic. It reacts quickly in the stratum corneum minimizing systemic absorption. The acute toxicity of DHA was investigated for diabetics in the 1920s with oral intake well tolerated (24). The phosphate of DHA is found naturally as one of the intermediates in the Krebs's cycle. Toxicity based on inhalation in closed spray-on tanning booths is unknown.

Contact dermatitis to DHA has only rarely been reported (33,34). As with other topical products with active ingredients, such as sunscreens, much of the reported sensitivity is secondary to other ingredients in the vehicle (35). Adverse reactions are more likely to occur on the basis of irritation and not true allergy. Ultimately, all claims related to product safety are based on testing the final formulation.

Although not approved by regulatory agencies, some of the alternative agents for increasing skin pigmentation (Table 23.1) are available to individuals. Tanning pills containing carotenoids such as canthaxanthin have been reported to cause retinopathy, urticaria, hepatitis, and aplastic anemia (36). More recently, injections of analogues of melanocyte-stimulating hormone may be gaining in popularity (37). Of potential benefit to individuals with photosensitive disorders (38), synthetic analogues of  $\alpha$ -MSH may drive proliferation of neoplastic melanocytic cells in the nevi of predisposed individuals (39).

## CONCLUSION

Increasing awareness as to the hazards of ultraviolet light should fuel ongoing interest in self-tanning products. It is incumbent on dermatologists to be familiar with this category. The benign toxicologic profile of DHA reinforces the notion that these products represent a safe alternative to a UV-induced tan. The results obtained are dependent on the final formulation, individual application technique, and the consumers' skin type. Greater experience in formulation combined with increasing sophistication on the part of the consumers has led to increasing satisfaction with the use of these products.

Users need to be clearly informed that these products do not offer significant protection against UVB. If the products are formulated with standard sunscreens, individuals should be cautioned that the duration of UV protection is more short-lived than the color change.

## REFERENCES

- Brooks K, Brooks D, Dajani Z, et al. Use of artificial tanning products among young adults. *J Am Acad Dermatol* 2006; 54(6):1060-1066.
- Beckmann KR, Kirke BA, McCaul KA, et al. Use of fake tanning lotions in the South Australian population. *Med J Aust* 2001; 174(2):75-78.
- Stryker JE, Yaroch AL, Moser RP, et al. Prevalence of sunless tanning product use and related behaviors among adults in the United States: results from a national survey. *J Am Acad Dermatol* 2007; 56(3):387-390.
- Mahler HI, Kulik JA, Harrell J, et al. Effects of UV photographs, photoaging information, and use of sunless tanning lotion on sun protection behaviors. *Arch Dermatol* 2005; 141(3):373-380.
- Sheehan DJ, Leshner JL. The effect of sunless tanning on behavior in the sun: a pilot study. *South Med J* 2005; 98(12):1192-1195.
- Wenninger JA, McEwen GN Jr., eds. *International Cosmetic Ingredient Dictionary and Handbook*. 11th ed. Washington: The Cosmetic, Toiletry, and Fragrance Association, 2006.
- Brown DA. Skin pigmentation enhancers. *J Photochem Photobiol* 2001; 63:148-161.
- Maes DH, Marenus KD. Self-tanning products. In: Baran R, Maibach HI, eds. *Textbook of Cosmetic Dermatology*. 3rd ed. United Kingdom: Taylor & Francis, 2005:225-227.
- Aretz C, Buczys R, Buchholz K, et al. Degradation reactions of dihydroxyacetone. *Euro Cosmetics* 1999; 6:32-36.
- Wittgenstein E, Berry HK. Reaction of dihydroxyacetone (DHA) with human skin callus and amino compounds. *J Invest Dermatol* 1961; 36:283-286.
- Meybeck A. A spectroscopic study of the reaction products of dihydroxyacetone with aminoacids. *J Soc Cosmet Chem* 1977; 28:25-35.
- Lloyd RV, Fong AJ, Sayre RM. In vivo formation of Maillard reaction free radicals in mouse skin. *J Invest Dermatol* 2001; 117:740-742.
- Purcetti G, Leblanc RM. A sunscreen tanning compromise: 3D visualization of the actions of titanium dioxide particles and dihydroxyacetone on human epidermis. *Photochem Photobiol* 2000; 71:426-430.
- Maibach HI, Kligman AM. Dihydroxyacetone: a suntan-simulating agent. *Arch Dermatol* 1960; 82:505-507.
- Pierard GE, Pierard-Franchimont C. Dihydroxyacetone test as a substitute for the dansyl chloride test. *Dermatology* 1993; 186(2):133-137.
- Forest SE, Grothaus JT, Ertel KD, et al. Fluorescence spectral imaging of dihydroxyacetone on skin in vivo. *Photochem Photobiol* 2003; 77:524-530.
- Goldman L, Barkoff J, Blaney D, et al. The skin coloring agent dihydroxyacetone. *Gen Pract* 1960; 12:96-98.
- Levy SB. Dihydroxyacetone-containing sunless or self-tanning lotions. *J Am Acad Dermatol* 1992; 27:989-993.
- Nguyen BC, Kochevar IE. Influence of hydration on dihydroxyacetone-induced pigmentation of stratum corneum. *J Invest Dermatol* 2003; 120:655-661.
- Nguyen BC, Kochevar IE. Factors influencing sunless tanning with dihydroxyacetone. *Br J Dermatol* 2003; 149:332-340.
- Rogers CJ. Spray-on tanning. *Aesthetic Surg J* 2005; 25:413-415.
- Chaudhuri RK. Dihydroxyacetone: chemistry and applications in self-tanning products. In: Schlossman ML, ed. *The Chemistry and Manufacture of Cosmetics*. Vol 3. Carol Stream, IL: Allred Publishing Corporation, 2002:383-402.
- Muizzuddin N, Marenus KD, Maes DH. UV-A and UV-B protective effect of melanoids formed with dihydroxyacetone and skin. Poster 360 presented at the 55th Annual Meeting of the American Academy of Dermatology, San Francisco, 1997.
- Faurschou A, Janjua NR, Wulf HC. Sun protection effect of dihydroxyacetone. *Arch Dermatol* 2004; 140:886-887.
- Faurschou A, Wulf HC. Durability of the sun protection factor provided by dihydroxyacetone. *Photodermatol Photoimmunol Photomed* 2004; 20:239-242.

26. Johnson JA, Fusaro RM. Protection against long ultraviolet radiation: topical browning agents and a new outlook. *Dermatologica* 1987; 175:53–57.
27. Petersen AB, Na R, Wulf HC. Sunless skin tanning with dihydroxyacetone delays broad spectrum ultraviolet photocarcinogenesis in hairless mice. *Mutat Res* 2003; 542:129–138.
28. Fitzpatrick TB. The validity and practicality of sunreactive skin types I through IV. *Arch Dermatol* 1988; 124:869–871.
29. Rajatanavin N, Suwanachote S, Kulkollakarn S. Dihydroxyacetone: a safe camouflaging option in vitiligo. *Int J Dermatol* 2008; 47:402–406.
30. Suga Y, Ikejima A, Matsuba S, et al. Medical pearl: DHA application for camouflaging segmental vitiligo and piebald lesions. *J Am Acad Dermatol* 2002; 47:436–438.
31. Fusaro RM, Johnson JA. Photoprotection of patients sensitive to short and/or long ultraviolet light with dihydroxyacetone/naphthoquinone. *Dermatologica* 1974; 148:224–227.
32. Taylor CR, Kwagsukstith C, Wimberly J, et al. Turbo-PUVA: dihydroxyacetone-enhanced photochemotherapy for psoriasis: a pilot study. *Arch Dermatol* 1999; 135:540–544.
33. Bovenschen HJ, Korver JEM, Van der Valk PGM, Van der Valk PGM. Contact dermatitis to self-tanning products. *Contact Dermatitis* 2009; 60:290–291.
34. Kimura T. Contact dermatitis caused by sunless tanning treatment with dihydroxyacetone in hairless descendants of mexican hairless dogs. *Environ Toxicol* 2008; 1:1–7.
35. Foley P, Nixon R, Marks R, et al. The frequency of reaction to sunscreens: results of a longitudinal population-based study on the regular use of sunscreens in Australia. *Br J Dermatol* 1993; 128:512–518.
36. Bluhm R, Branch R, Johnston P. Aplastic anemia associated with canthaxanthin ingested for tanning purposes. *JAMA* 1990; 264:1141–1142.
37. Mazza JM, Zippin JH. An  $\alpha$ -melanocyte-stimulating hormone analogues: the perils and the promise. *J Drugs Dermatol* 2009; 8:772–775.
38. Harms J, Lautenschlager S, Minder C, et al. An  $\alpha$ -melanocyte-stimulating hormone analogue in erythropoietic protoporphyria. *N Engl J Med* 2009; 360:307–308.
39. Carderones AR, Grichnik JM.  $\alpha$ -melanocytic-stimulating hormone-induced eruptive nevi. *Arch Dermatol* 2009; 145:441–444.

## Astringents, masks, and ancillary skin care products

Zoe Diana Draelos

### INTRODUCTION

Ancillary skin care encompasses products designed to supplement basic cleansing and moisturizing of the skin. Frequently, these products are recommended as part of a skin care routine designed to impart benefits above and beyond basic hygiene needs or maintenance of the skin barrier. Ancillary skin care products include astringents, exfoliants, facial scrubs, epidermabrasion, textured cloths, mechanized skin care devices, and face masks. This chapter discusses these ancillary skin care products and their dermatologic value.

### ASTRINGENTS

Astringents are liquids applied to the face following cleansing. They comprise a broad category of formulations known by many terms: toners, clarifying lotions, controlling lotions, protection lotions, skin fresheners, toning lotions, T-zone tonics, etc. Originally, astringents were developed to remove alkaline soap scum from the face following cleansing with lye-based soaps and high-mineral content well water. The development of synthetic detergents (syndets) and public softened water systems greatly decreased the amount of post-washing residue. A new use for astringents was found when cleansing cream became a preferred method of removing facial cosmetics and environmental dirt. The astringent then became an effective product for removing the oily residue left behind following cleansing cream use.

Astringent formulations are presently available for all skin types (oily, normal, dry, sensitive, photoaged, etc.), with a variety of uses (1). Oily skin astringents contain a high concentration of alcohols, water, and fragrance functioning to remove any sebum left behind following cleansing to produce a clean feel and to possibly deliver some treatment product to the face. For example, 2% salicylic acid or witch hazel may be added for a keratolytic and drying effect on the facial skin of acne patients. Clays, starches, or synthetic polymers may be added to absorb sebum and minimize the appearance of facial oil. Astringents for normal skin are generally formulated to give the skin a clean, fresh feeling without much dryness. They may contain propylene glycol to function as a humectant, a water-attracting mild moisturizing agent.

Products formulated for dry or sensitive skin are alcohol-free and are based on light-weight occlusive moisturizers, such as silicone (dimethicone, cyclomethicone). In addition, soothing agents such as allantoin, guaiazulene, and quaternium-19 may be added. The newest type of astringents are those designed for photoaged skin that contain salicylic acid ( $\beta$ -hydroxy acid) or glycolic acid ( $\alpha$ -hydroxy acid) to aid in keratinocyte exfoliation and achieve smoother, more evenly pigmented skin.

### EXFOLIANTS

Exfoliants are solutions, lotions, or creams applied to the face following cleansing designed to hasten stratum corneum exfoliation. They are similar in function to the antiaging astringents previously discussed. Their exfoliant effect is based on the use of  $\alpha$ -, poly-, or  $\beta$ -hydroxy acids, thus inducing chemical exfoliation.

Exfoliants containing hydroxy acids produce both epidermal and dermal changes. The epidermal changes are immediate and occur at the junction of the stratum corneum and stratum granulosum. They consist of a reduction in the thickness of the hyperkeratotic stratum corneum due to decreased corneocyte adhesion (2). The dermal effects, which are delayed, consist of increased glycosaminoglycan synthesis (3). These effects are most pronounced with the  $\alpha$ -hydroxy acids (glycolic acid, lactic acid, malic acid), which rapidly penetrate the epidermis to enter the dermis. Individuals with sensitive skin may not be able to tolerate the low pH of 3 required to cause this epidermal renewal (4). This has led to development of polyhydroxy acids (gluconolactone, lactobionic acid, ferulic acid), which are larger molecular weight hydroxy acids that do not penetrate as rapidly to the dermis. This produces less irritation allowing polyhydroxy acid use by persons with sensitive skin, eczema, and atopic dermatitis.

Another mechanism for reducing the irritation of chemical exfoliants is through neutralization or buffering. Irritation can also be minimized by raising the exfoliant pH through sodium hydroxide neutralization; however this also reduces the exfoliation produced. The use of buffering agents, such as phosphoric acid or monosodium phosphate, is preferable since the buffer maintains the product at a desired pH (5). Ideally, the pH of an exfoliant solution should not be lower than 3. More exfoliation is induced with lower pH, since the hydroxy acid concentration is increased, but more irritation in the form of stinging and burning is also expected.

$\beta$ -Hydroxy acids, such as salicylic acid, may also be used, but do not produce dermal penetration. Salicylic acid is technically not a  $\beta$ -hydroxy acid, but rather a phenolic compound, but the marketing nomenclature has popularized this terminology. Salicylic acid is an oil-soluble acid, as compared to the  $\alpha$ -hydroxy acids that are mainly water soluble, and remains on the skin surface. Since exfoliation occurs on the skin surface, this is a desirable characteristic that minimizes irritation. Salicylic acid is also able to exfoliate within the follicular ostia, making it the exfoliant of choice in acne patients as well as sensitive skin patients. Salicylic acid is listed on the acne monograph and functions as a keratolytic in many over-the-counter acne preparations.

## FACIAL SCRUBS

Facial scrubs are mechanical exfoliants, as opposed to the chemical exfoliants previously discussed, employing small granules in a cleansing base to enhance corneocyte desquamation. The scrubbing granules may be polyethylene beads, aluminum oxide, ground fruit pits, or sodium tetraborate decahydrate granules aiding in the removal desquamating stratum corneum from the face (6). Sibley et al. considered abrasive scrubbing creams effective in controlling excess sebum and removing desquamating tissue (7). However, they can cause epithelial damage if used too vigorously. This view is held by Mills and Kligman, who noted that the products produced peeling and erythema without a reduction in comedones. Aluminum oxide and ground fruit pits provide the most abrasive scrub because of their rough-edged particles, followed by polyethylene beads, which are smoother and produce less stratum corneum removal. Sodium tetraborate decahydrate granules become softer and dissolve during rubbing, providing the least abrasive scrub.

A currently popular trend in facial exfoliant scrubs is the production of warmth. These products are labeled as “self-heating” scrubs. The heat is produced as part of an exothermic reaction resulting in the heat by-product. The heat does not increase exfoliant efficacy but is added for consumer comfort and marketing purposes. Sometimes these heated exfoliant scrubs are preceded by a self-administered hydroxy acid peel, thus combining both chemical and physical exfoliation into one kit.

## EPIDERMABRASION AND TEXTURED CLOTHS

Another mechanical method of enhancing stratum corneum exfoliation has been labeled epidermabrasion by Durr and Orentreich, who examined the use of a nonwoven polyester fiber web sponge for the removal of keratin excrescences and trapped hairs in pilosebaceous ducts (8–10). Other epidermabrasion implements include rubber puffs, sea sponges, loofahs, and the most recent addition of textured fibered face cloths. The fibered face cloths have become a large segment of the current epidermabrasion marketplace and therefore are discussed in detail.

Fibered cloths are extremely versatile dermatologic devices. They can be premoistened and impregnated with surfactants to cleanse the face, be perfumed containing volatile solvents to freshen the face, be packaged dry with lipids and detergents to clean the face, be covered with a plastic film pouch with microscopic holes to time release an active onto the skin surface, and be textured with patterns to physically exfoliate the skin. Even though many of the facial uses of fibered cloths are new, the clothes have been around for 30 years.

The first fibered clothes were introduced as baby wipes. They were made from carded rayon fibers that were held together by adhesive binders. They exhibited wonderful strength for their thickness, but were rather coarse and a frequent cause of irritant contact dermatitis due to both the surfactants employed and the rough cloth texture. The need for a strong, but soft cloth led to development of air-laid nonwoven fibered clothes in the mid 1970s. These clothes were composed of wood pulp, polyester, and adhesive binders. These clothes were thicker and softer. The technology was further developed in the 1980s by adding both cotton and rayon fibers to improve strength.

Modern fibered cloth technology focused on creating a soft wipe with excellent strength to prevent tearing. The fibers used are a combination of polyester, rayon, cotton, and cellulose fibers held together via heat through a technique known as thermobonding. Additional strength is imparted to the wipe by hydroentangling the fibers. This is achieved by entwining the individual rayon, polyester, and wood pulp fibers with high-pressure jets of water. Thermobonding and hydroentangling have eliminated the use of adhesive binders thereby creating a soft, strong cloth suitable for facial use.

Face clothes can available both dry and moist. The dry packaged cloths are impregnated with a cleanser that foams modestly when the cloth is water moistened. The type of cleanser in the cloth can produce aggressive sebum removal for oily skin or minimal sebum removal for dry skin. Humectants and emollients can also be added to the cloth to decrease barrier damage or to smooth xerotic skin scale. Thus, face cloths can be designed for normal to oily skin, normal to dry skin, or sensitive skin.

In addition to the composition of the ingredients preapplied to the dry cloth, the weave of the cloth will also determine its cutaneous effect. There are two types of fiber weaves used in facial products: open weave and closed weave. Open weave cloths are so named because of the 2 to 3 mm windows in the cloth between the adjacent fiber bundles. These clothes are used in persons with dry and/or sensitive skin to increase the softness of the cloth and decrease the surface area contact between the cloth and the skin yielding a milder exfoliant effect. Closed weave cloths, on the hand, are designed with a much tighter weave and are double sided. One side of the closed weave cloth is textured and impregnated with a synthetic detergent cleanser designed to optimize the removal of sebum, cosmetics, and environmental dirt while providing an exfoliant effect. The opposite side of the cloth is smooth and designed for rinsing the face and possibly applying skin conditioning or antiaging agents. Some of the newer cloths contain a central petrolatum strip designed to leave behind a moisturizer on the skin during the rinse process.

The texture of the cloth provides gentle mechanical exfoliation that may be valuable in the patient who cannot tolerate chemical exfoliation with hydroxy acids. The mechanical exfoliation can be achieved on the skin surface and around the follicular ostia because of the ability of the textured cloth to traverse the irregular topography of the skin more effectively than the hands or a wash cloth. The degree of exfoliation achieved is dependent on the cloth weave, the pressure with which the cloth is stroked over the skin surface, and the length of time the cloth is applied.

Figure 24.1 provides a demonstration of the amount of facial foundation left behind on the skin after cleansing with a variety of different techniques. The pads contain unremoved



Figure 24.1 Cleansing cloth: facial foundation removal.



cosmetic. Notice that there is a small amount of cosmetic on the pad after using either a closed weave or an open weave cloth. More cosmetic is left behind after soap cleansing and even more after using a lipid-free cleanser. This illustration demonstrates the cleansing attributes of a face cloth.

### **MECHANIZED SKIN CARE DEVICES**

Mechanization of the epidermabrasion process is known as microdermabrasion. This is a procedure performed by estheticians and paramedical personnel where small particulates, such as aluminum, silica, and baking soda, are sprayed against the skin surface and simultaneously removed with a vacuum. Microdermabrasion simply represents another technique to induce stratum corneum exfoliation, a natural body process that slows with advancing age.

A variety of devices are available to exfoliate the facial skin. These include rotary brushes that drag synthetic bristles across the skin surface to physically remove the stratum corneum. These devices are sold with a special cleanser to remove sebum and clean the bristles simultaneously. A variant of this technology used scrubbing pads of various roughnesses to produce exfoliation. The scrubbing pads were held on the device head with adhesive and could be replaced when worn. These devices vibrated instead of rotating to remove skin scale.

A third type of facial cleansing device produces a sonicating motion, similar to the sonicating electric toothbrushes. The hand-held device runs on a rechargeable battery that is attached to a miniaturized motor creating an oscillatory motion of the brush head. This oscillatory sonic motion allows the brush bristles to traverse the dermatoglyphics, facial pores, and facial scars more adeptly than other mechanized cleansing methods.

### **FACE MASKS**

Face masks are the last ancillary skin care product discussed and consist of substances applied to the face for an extended time period for therapeutic and/or esthetic purposes. Masks are available for home purchase and professional use. They may be packaged in a jar or bottle for immediate application to the face or as dry ingredients in a pouch for mixing with water. Typically, a mask is applied on a weekly basis to provide a time for relaxation, an esthetically pleasing sensation, and skin benefits. There are four basic mask formulations: wax-based, vinyl or rubber-based, hydrocolloid and earth-based.

#### **Wax Masks**

Wax masks are popular among women who visit professional spas for their warm, esthetically pleasing feel. They are composed of beeswax or, more commonly, paraffin wax to which petroleum jelly and cetyl or stearyl alcohols have been added to provide a soft, pliable material for facial application with a soft brush. The wax is heated in a pot placed in a water bath to control the temperature and prevent burning. Sometimes the wax is dipped from the pot and painted over the face and other times it may be brushed over thin cotton gauze draped over the face. Gauze is commonly used to enable the facial technician to remove the wax in one piece (11). Gauze also prevents the wax from sticking to the vellus hairs on the face, which may be painfully epilated as the wax is peeled from the face.

Wax-based face masks temporarily impede cutaneous transepidermal water loss. This effect is limited only to the time the mask is in direct contact with the face, unless a suitable occlusive

moisturizer is applied immediately following mask removal. For this reason, they are popular in persons with dry skin.

#### **Vinyl and Rubber-Based Masks**

Vinyl and rubber-based masks are popular masks for home use, since they are easily squeezed from a pouch onto the face and removed in one piece. Rubber-based masks are usually based on latex, while vinyl-based masks are based on film-forming substances, such as polyvinyl alcohol or vinyl acetate. Because of the concern over latex allergy, there are no true rubber-based masks for home use.

Vinyl masks are squeezed premixed from a tube or pouch and applied with the fingertips or a wooden applicator to the face. Upon evaporation of the vehicle, a thin flexible vinyl film remains behind on the face. The mask is generally left in contact with the skin for 10 to 30 minutes and then peeled in one sheet by loosening the edges from the face.

Vinyl and rubber masks are appropriate for all skin types. The evaporation of the vehicle from the wet mask creates a cooling sensation, and the shrinking of the mask with drying may give the impression that the skin is actually tightening. These masks can temporarily impede transepidermal water loss while they are in contact with the skin.

#### **Hydrocolloid Masks**

Hydrocolloid masks are used both in professional salons and at home. Hydrocolloids are substances, such as oatmeal, that are of large molecular weight and thus interfere with transepidermal water loss. These masks are formulated from gums and humectants and enjoy tremendous popularity since many specialty ingredients are easily incorporated into their formulation. They are marketed in the form of dry ingredients in a sealed pouch that must be mixed with warm water prior to application. The resulting paste is then smeared over the face with the hands or a wooden blade and allowed to dry (12).

Hydrocolloid masks leave the skin feeling smooth and create the sensation of skin tightening as the water evaporates and the mask dries. Temporary moisturization can occur while the mask is on the skin. Specialty additives such as honey, egg whites, chamomile flowers, aloe vera, almond oil, zinc oxide, sulfur, avocado, and witch hazel may be used to customize the mask. Many spas have their own special concoction. By varying the ingredients, masks can be created for all skin types. In addition, herbal medicine can be practiced by combining various healing plants into a poultice for facial application.

#### **Earth-Based Masks**

Earth-based masks, also known as paste masks or mud packs, are formulated of absorbent clays such as bentonite, kaolin, or china clay. The clays produce an astringent effect on the skin making this mask most appropriate for oily-complected patients. The astringent effect of the mask can be enhanced through the addition of other substances such as magnesium, zinc oxide, and salicylic acid.

### **SUMMARY**

This chapter has discussed the various ancillary skin care products for purchase in the current marketplace. Astringents represent a broad category and may impart both cleansing and moisturizing effects to the skin, depending on formulation and skin type. Exfoliants, which became popular when glycolic acid

was introduced to the antiaging marketplace, can contain both chemical and physical exfoliating ingredients to enhance desquamation of the stratum corneum. Physical exfoliating agents are commonly packaged as particulate facial scrubs, woven sponges, or textured cloths. Textured cloths are the newest introduction and can function like disposable washcloths or may leave behind ingredients on the skin surface. Mechanized skin care devices attempt to deliver at home microdermabrasion with rotary, vibrating, or sonicating motors. Finally, face masks deliver both esthetic and skin care benefits in a professional or home environment.

Ancillary skin care is an interesting area that combines devices and products to offer innovative solutions to skin care. These products can be used alone or in combination to deliver exfoliant, antiaging, moisturizing, astringent, or aesthetic benefits. Most of the new introductions in the commercial skin care market have occurred in this arena, since the profit margin is high and consumers are now focusing on cleansing as a way of enhancing the skin appearance. While cleansing has traditionally been a method to obtain good skin hygiene and minimize infection, a new concept in skin care is the expansion of cleansing beyond soap and water to include astringents, exfoliants, facial scrubs, epidermabrasion, textured cloths, mechanized skin care devices, and face masks.

## REFERENCES

1. Wilkinson JB, Moore RJ. Astringents and skin toners. In: *Harry's Cosmeticology*. 7th ed. New York: Chemical Publishing, 1982:74-81.
2. Dietre CM, Griffin TD, Murphy CF, et al. Effects of alpha-hydroxy acids on photoaged skin. *J Am Acad Dermatol* 1996; 34:187-195.
3. Van Scott JE, Yu RJ. Hyperkeratinization, corneocyte cohesion and alpha hydroxy acids. *J Am Acad Dermatol* 1984; 11:867-879.
4. Smith WP. Hydroxy acids and skin aging. *Cosmet Toil* 1994; 109: 41-48.
5. Yu RJ, Van Scott EJ. Alpha hydroxy acids: science and therapeutic use. *Cosmet Dermatol* 1994; 7(10s):12-20.
6. Mills OH, Kligman AM. Evaluation of abrasives in acne therapy. *Cutis* 1979; 23:704-705.
7. Sibley MJ, Browne RK, Kitzmiller KW. Abradant cleansing aids for acne vulgaris. *Cutis* 1974; 14:269-274.
8. Durr NP, Orentreich N. Epidermabrasion for acne. *Cutis* 1976; 17: 604-608.
9. Mackenzie A. Use of Buf-Puf and mild cleansing bar in acne. *Cutis* 1977; 20:170-171.
10. Millikan LE, Ameln R. Use of Buf-Puf and benzoyl peroxide in the treatment of acne. *Cutis* 1981; 28:201-205.
11. Gerson J. *Milady's Standard Textbook for Professional Estheticians*. Buffalo, NY: Milady, 1992:240-242.
12. Draelos ZD. *Cosmetics in Dermatology*. 2nd ed. Edinburgh: Churchill Livingstone (WB Saunders), 1995:213.

# Cosmeceuticals

Marianne Nelson O'Donoghue

## INTRODUCTION

Cosmeceuticals as defined by Albert Kligman, MD (1), are products which are promoted with aggressive claims to have a favorable impact on the condition of the skin. They have revolutionized skin care because of their ability to improve the appearance and function of skin without cosmetic surgery. They are between drugs and cosmetics, and thus they are not regulated by most governments.

The categories usually include

antioxidants,  
 $\alpha$ -hydroxy acids,  
 antiperspirants,  
 sunscreens, and  
 self-tanners.

This chapter will deal with an overview of these categories, since some of these categories will be discussed in greater detail by other authors.

## ANTIOXIDANTS

In 1984 L.H. Kligman demonstrated that connective tissue could be repaired in the rhino mouse with tretinoin (2). Subsequently this was established in humans with multicenter, double-blind study over a 48-week period (3). This ushered a new method of skin care for photoaging, cancer, and cosmetic reasons. The gold standard for the reversal of photoaging is tretinoin, but because of its irritant potential, other products have been studied.

Antioxidants are products that quench or offset free radicals. These occur because of sunlight, pollution, stress, heavy metals, drugs, and normal metabolism. Free radicals have a role in skin carcinogenesis, inflammation, and aging. The mechanism by which they disturb the homeostasis is that the oxygen molecules combine with the other molecules and are left with an odd number of electrons. Oxygen with an unpaired electron is reactive, because it takes electrons from vital components leaving them damaged. DNA, cytoskeletal elements, and cellular membranes may all be adversely affected.

Antioxidants couple with unpaired electrons to disarm or offset the free radicals.

Naturally occurring antioxidants include the following:

Vitamins

A, B3 (niacinamide), B5 (panthenol), C, E

Other natural-occurring antioxidants

$\alpha$ -Lipoic acid,  $\beta$ -carotene, catalase, glutathione

Superoxide dismutase, ubiquinone (CoQ 10)

Plant antioxidants

Green tea polyphenols

Silymarin

Soy isoflavones

Furfuryladenine (kinerase)

Additional antioxidants and cosmeceuticals

Rosemary

Oatmeal

Olive oil

Grape seed extract

Tea tree oil

Coffeeferry extract

Idebenone

These ingredients have been incorporated in many products over the past 15 years. Their success at performing at a cellular level to improve the quality of the skin will be covered extensively elsewhere in this text.

It is important to realize that these different antioxidants network together to stop cellular damage. They are capable of recycling each other.

Vitamin E is recycled by vitamin C or CoQ 10.  $\alpha$ -Lipoic acid can recycle vitamins C, glutathione, and vitamin E (4). The model for testing most of the antioxidants is the use of these products before, during, and after sun exposure (5-7). The results were a lack of erythema, sunburn cell production, or other signs of ultraviolet (UV) damage. These scientists also tested the ability of the skin to keep its immunity. Sun can cause immunosuppression. This can stop cancer surveillance. These antioxidants can prevent the immunosuppression from occurring (8).

The Plant antioxidants synergize with vitamins C and E. They also help in recycling. These products have been demonstrated to act as photoprotectant network antioxidants. They also help with dispigmentation. The major ones are green tea polyphenols, silymarin, soy isoflavonones, and furfuryladenine. The difficult problem with the green tea polyphenols is keeping the products fresh.

Furfuryladenine has been added to cell cultures of human fibroblasts and has allowed them to be assayed many times (9). This substance stimulates plant growth, retards leaf senescence, and modulates the plant to resist environmental stresses. In a study performed at the University of California, Irvine, clinical trials for N6-furfuryladenine (kinerase) compared this substance with 0.05% tretinoin emollient cream. ICN Pharmaceuticals sponsored these studies. At 24 weeks, physicians determined that there was overall improvement in the parameters of wrinkling, dispigmentation, and erythema with the furfuryladenine product compared with the tretinoin product, but there was less irritation. This product is helpful, but would be used only if a patient could not tolerate tretinoin products or some of the other antioxidants.

$\beta$ -Hydroxyacids (usually salicylic acid) have been used as keratolytics for acne-prone skin and as exfoliants for normal

skin. If a facial-colored cosmetic is labeled "For Acne," it usually contains 2% salicylic acid.

$\beta$ -Hydroxyacids have been used most recently in normal patients for gentle face peels. These acids can penetrate the oily milieu of the sebaceous units. By dissolving the intercellular cement, salicylic acid may induce corneocytes separation and desquamation in the oily areas of the face (10). These can stimulate exfoliation, which is another tool for facial rejuvenation.

## ADDITIONAL ANTIOXIDANTS AND COSMECEUTICALS

*Rosemary* as a substance is better known as a spice, but it is a potent antioxidant because of its phenolic diterpenes. It has been shown to suppress tumorigenesis in the two-stage skin cancer model in mice. It also exhibits photoprotection in mice.

*Oatmeal* has always been soothing and anti-inflammatory. It can repair skin and hair damage from UV radiation, smoke, bacteria, and free radicals.

*Olive oil* contains polyphenolic compounds with protect against inflammation. It is found in soaps, lip balms, shampoos and moisturizers. Extravirgin olive oil has protected mice after UV exposure.

*Grape seed extract* is an antioxidant because of its oligomeric proanthocyanides (OPC). These compounds are in the flavinoid family which is most famous for green and black tea. This extract helps vascular endothelial growth factor expressed in keratinocytes which fosters wound healing. It also scavenges free radicals for vitamins C and E.

*Tea tree oil* has been used widely in hair and skin products because of its activity against *Propionibacterium acnes* and trichophyton dermatophytes. It is very popular in beauty salon products. It has the highest rate of contact dermatitis of the cosmeceuticals. Many reports have come from Great Britain. Its efficacy in antidandruff shampoos needs to be proven.

*Coffeaberry* is a proprietary name for antioxidants harvested from the fruit of the coffee plant—*Coffea arabia*. The fruit is harvested in a subripened state because that is the peak of antioxidant activity. Coffeaberry contains potent polyphenols including chlorogenic acid and ferrulic acid among others. The plant is used for cellulite.

*Idobenone* is a synthetic analog of coenzyme Q10. As such it is a powerful antioxidant. Clinically it has been demonstrated to improve fine lines and wrinkles in the periorbital area and a lightening of facial dyschromia in concentrations of both 0.05% and 1%.

All of these antioxidants have been put into formulation to help fine and coarse wrinkling, dyspigmentation, and erythema. The new technology of consistent positioning of the patient for photography, consistent lighting, and computer measurement of wrinkles, discoloration, and skin folds has allowed a scientific assessment of these products. Many of these work well.

The gold standard of improving skin quality is still tretinoin, in whatever formulation it occurs. Some patients cannot tolerate the irritation from tretinoin; for those people the antioxidant cosmetics are appropriate. Some patients can combine tretinoin with antioxidants successfully.

## $\alpha$ -HYDROXY ACIDS

Before the tretinoin products were introduced,  $\alpha$ -hydroxy acids went from medical uses for ichthyosis vulgaris, lamellar ichthyosis, and many other hyperkeratotic diseases to some cosmetic uses. They became incorporated in shampoos, mois-

turizers, bleaching agents, and many other products to enhance penetration or absorption. Lactic acid has been used in dermatology for many years. Van Scott's research (11) ushered in a decade of the use of these products. These natural fruit acids exert their influence by diminishing corneocyte cohesion. The most commonly used ingredients are as follows:

Glycolic acid	Sugarcane
Lactic acid	Sour milk
Malic acid	Apples
Citric acid	Citrus fruits
Tartaric acid	Grapes

Leyden (12) has outlined the functions of these products clearly.

1. They bind water in the skin; therefore, the stratum corneum becomes more flexible.
2. They normalize desquamation of corneocytes from the stratum corneum. This may occur by interaction with corneum lipids.
3. They release cytokines locally.
4. They cause a thickening of the epidermis.
5. They increase production of hyaluronic acid within the dermis. This may be due to the increased production of transforming growth factor  $\beta$ .
6. In both ichthyosis and thickening stratum corneum of dry skin, the  $\alpha$ -hydroxy acids make the skin thin down toward normal.

## ANTIPERSPIRANTS

Antiperspirants are considered a drug because of their physical interaction with the sweat duct. Because of this, they do have some regulation by the government in the United States. These products, which contain aluminum salts, act by causing a precipitation in the duct itself to block the secretion of sweat. They must have a specific amount of aluminum salts and in laboratory tests must reduce sweat by at least 20% in half of the people tested. There have been a few reports of axillary granular parakeratosis (13) from aluminum salts or from deodorants. Cessation of the aluminum salts in some patients has cured the eruption. Some patients have required more aggressive therapy. The eruption resembles familial pemphigus.

Deodorants only contain bacteria-killing agents such as triclosan to decrease the odor. These are therefore only cosmetic. For efficacy, roll-on products are the best, followed by the stick formulations, and then the spray-on products. These spray-on products may be irritating to the axillae.

## SUNSCREENS

Sunscreens continue to be the best cosmeceutical to prevent photoaging. Because of the prevention of skin cancer, they may be considered to be either a drug or a cosmeceutical. They are evaluated by their SPF factor in UVB sunblocks, and the ability of a UVA sunscreen to be a broad-spectrum block.

The SPF value is the ratio of UVB dose required to produce the minimal erythema reaction through the applied sunscreen product (2 mg/cm<sup>2</sup>). The UVA sunscreens are usually tested with psoralens and UV light, or with special solar simulators.

The major failure today of sunscreen is that patients do not apply enough. They often use only .05 mg/cm<sup>2</sup> (14), or even lower amounts. Reapplication every three or four hours is also necessary in some situations.

There are two major types of sunblocks—physical and chemical.

### Physical Sunblocks

The major ingredients of these products are zinc oxide and titanium dioxide.

The older formulations of zinc oxide and titanium dioxide were thick, messy, and unattractive. The advantages of these products however, are that they reflected sun off of the skin, were good against UVB and UVA, and were not allergenic. They still have a place below the eyes, on the nose, and on the shoulders of young children.

With the advent of pulverization of these molecules, more elegant preparations are available which are the microfine zinc, and microfine titanium dioxide. These must be combined with a waterproof vehicle to give substantivity to these products. The advantages of physical sunscreens are: good coverage, no allergic or photoallergic reactions, waterproof, chemical free, superior coverage for UVA, good coverage for UVB.

The disadvantages are: a mask-like or opaque appearance, a violet color may be imparted to the skin, and some claim the TiO<sub>2</sub> can break down with UV exposure.

### Chemical Sunblocks

#### UVB Absorbers (All Are 290–310)

*Cinnamates.* Octyl methoxycinnamate and cinoxate are the most common UVB sunscreen ingredients at this time. These ingredients are easily incorporated in skin and hair cosmetics, rarely cause allergic reactions, and do not stain clothing. They are in most products throughout the world, and they are often used in combination with other ingredients.

*Salicylates.* Homomenthyl, octyl, and triethanolamine salicylates are often used to Elevate the SPF level in sunblocks. By themselves they are only an SPF of 3.5 to 4.5, but with other ingredients they are very effective.

*Octocrylene.* This ingredient has been used most successfully with Parsol 1789, or Avobenzone. It is noncomedogenic, hypoallergenic, and a very good UVB blocker. It has been incorporated in many more products since 2005.

*Phenylbenzimidazole sulfonic acid.* This product has been used more commonly in the past few years. It is compatible with many other cosmetics, and as such, is used in more elegant products.

#### UVA Absorbers

*Benzophenones.* As our knowledge of the damage to the dermis, melanocytes, and Immunity grows, we are more aware that UVA contributes more than we realized (15).

UVA can pass through window glass, is present evenly all year long, and has been determined to have a severe effect in the skin. The major chemical ingredient for protection has been benzophenone (oxybenzone 270–390) and dioxybenzone (200–390). This still does not protect the skin from wavelengths 390 to 400.

The benzophenones are incorporated easily into cosmetic ingredients and usually do not cause contact dermatitis. When they are used in intense sun, however, such as near the Equator, high temperatures, and in desert type exposure, they can often cause a photoallergic reaction. These ingredients throughout the world have the highest incidence of a phototoxic or photoallergic reaction.

The spectrum usually peaks around UVA 284 or 327. This is not always adequate for good protection. These ingredients continue to be a major source of UVA block in sunscreens, moisturizers, and hair products.

### Parsol 1789 (Avobenzone)

This ingredient is the best chemical UVA block because of its range of It peaks at 358. This chemical mixes well cosmetically, is fairly hypoallergenic, and is in most of the broad-spectrum sunblocks. Because the UVB protection is weak, it must be combined with other ingredients. Many good products today combine octocrylene, benzophenone, and Parsol 1789.

The Parsol 1789 appears to prevent the photoallergic reactions associated with the benzophenones. Titanium dioxide is also often added for protection. Cinnamates were not compatible with Parsol 1789.

The most effective chemical UVA blockers in recent years have been Mexoryl and Helioplex. These products have been synthesized to allow Parsol 1789 to remain stable. Dr Henry Lim addresses these in detail in Chapter 26.

When an individual selects a sunblock, there are three characteristics that are important. The first is the SPF and broad-spectrum number. The second is whether the product is waterproof. This is measured by lap swimming for 80 minutes. The third important characteristic for the face is whether the product is noncomedogenic or not. Most of the physical and chemical sunscreens are labeled with this information. Many of the cosmetic sunscreens are not.

### SELF-TANNERS

Self-tanning lotions consist primarily of dihydroxyacetone (DHA). These have a protein-staining effect from the DHA in the stratum corneum of the skin. These products used to be orange and streaky but have been perfected to an even-colored tone by the addition of silicone to the vehicle. Although these are nontoxic, they may accentuate freckles and seborrheic keratoses and may therefore not be desirable. These products are discussed in greater detail in Chapter 23.

Bronzing gels consist of henna, walnut, juglone, and lawsone. These are water-soluble dyes to stain the skin. They can be messy to clothes and have the stickiness of a gel. They are usually noncomedogenic.

Tanning promoters, such as 5-methoxypsoralen, have been well documented to be highly phototoxic and carcinogenic. 5-Methoxypsoralen is used primarily in PUVA therapy and not for cosmetic reasons.

Tanning pills consist of Canthaxanthin and are toxic to both skin and eyes. These are not used in most countries today (16).

### REFERENCES

1. Kligman AM. Why cosmeceuticals? *Cosmet Toilet* 1994; 08:37–38.
2. Kligman LH, Duo CH, Kligman AM, et al. Topical Retinoic acid enhances the repair of ultraviolet damaged dermal connective tissue. *Connect Tissue Res* 1984; 12:139–150.
3. Olsen EA, Katz HI, Levine N, et al. Tretinoin emollient cream for photodamaged skin: results of 48-week, multicenter, double-blind studies. *J Am Acad Dermatol* 1997; 37:217–226.
4. Podda M, Grundmann-Kollmann M. Low molecular weight anti-oxidants and their role in skin aging. *Clin Exp Dermatol* 2001; 26: 578–582.

5. Darr D, Combs S, Dunston S, et al. Topical vitamin C protects porcine skin from ultraviolet radiation-induced damage. *Br J Dermatol* 1992; 127:247–253.
6. Elmets CA, Singh D, Tubesing K, et al. Cutaneous photoprotection from ultraviolet injury by green tea Polyphenols. *J Am Acad Dermatol* 2003; 44:425–432.
7. Lopez-Torres M, Theile JJ, Shindo Y, et al. Topical application of  $\alpha$ -tocopherol modulates the antioxidant network and diminishes ultraviolet-induced oxidative damage in murine skin. *Br J Dermatol* 1998; 138(2):207–215.
8. Steenvoorden DP, Beijersberger VH. Protection against UV-induced systemic immunosuppression in mice by a single topical application of the antioxidant Vitamin C and C. *Int J Radiat Biol* 1994; 201:665.
9. Ratten S, Clark B. Kinetin delays the onset of aging characteristics in human fibroblasts. *Biochem Biophys Res* 1994; 201:665.
10. Draelos ZD. Alpha-hydroxy acids and other topical agents. *Dermatol Ther* 2000; 13:154–158.
11. Van Scott EJ, Yu RJ. Hyperkeratinization, corneocyte cohesion, and alpha-hydroxy acids. *J Am Acad Dermatol* 1983; 11:867–879.
12. Leyden J. Alpha-hydroxy acids. *Dialog Dermatol* 1994; 34:3.
13. Mehregan DA, Vanderstean D, et al. Axillary granular parakeratosis. *J Am Acad Dermatol* 1995; 33:373–375.
14. Autier P, Boniol M, Serei G, et al. European organization for research and treatment of cancer melanoma co. Quantity of sunscreen used by European students. *Br J Dermatol* 2001; 144: 288–296.
15. Yaar M, Gilchrist BA. Skin aging postulated mechanism and consequent changes in structure and function. *Clin Geriatr Med* 2001; 17:617–630.
16. Jackson EM. Tanning without sun: accelerators, promoters, pills, bronzing gels, and self-tanning lotion. *Am J Contact Dermat* 1994; 5:38.

## FURTHER READING

- Baumann L. Less-known botanical cosmeceuticals. *Dermatol Ther* 2007; 20(5):330–342.
- Farris P. Idebenone, green tea, and Coffeeferry extract: new and innovative antioxidants. *Dermatol Ther* 2007; 20(5):322–329.
- Palm MD, O'Donoghue MN. Update on photoprotection. *Dermatol Ther* 2007; 20(5):360–376.

# Photodamage: prevention

Camile L. Hexsel and Henry W. Lim

## INTRODUCTION

Knowledge is expanding about the effects of electromagnetic radiation, which includes ultraviolet (UV)B, UVA, visible and infrared radiation. In the past few years, significant effort has been put into the development of sunscreens and other photoprotective methods with broad-spectrum UVA coverage; however, especially in the United States, debate still exists on how to objectively report the level of UVA protection of sunscreens to consumers.

Given the need of ideal protection against the full UVB and UVA spectrum, and given the recent evidence that both visible light and infrared radiation also have biologic effects on the skin, prevention of photodamage should be undertaken not only by proper application of sunscreens, but also by a combination of measures, including seeking shade during the peak UV hours of 10 AM to 4 PM, and the adjunctive use of physical barriers, such as wide-brimmed hat, tightly woven or specifically designed UV-protective clothing, and sunglasses. Because of the known physical and psychologic benefits of outdoor activities, it is not realistic or appropriate to advise patients to stay entirely indoor. Thus, proper education of photoprevention, as outlined above is essential (1).

Vitamin D is synthesized in the skin following exposure to UVB. It is long known to be associated with bone health; in the past few years, inadequate levels of vitamin D has been associated with other conditions, including heart and neurologic diseases, certain cancers, and mortality from all causes (2). Therefore, photoprotection message should be combined with advice for appropriate vitamin D supplementation. In mid-2009, several professional organizations, including American Academy of Dermatology, National Council for Skin Cancer Prevention, and Skin Cancer Foundation released position statements suggesting an intake of 1000 IU of vitamin D<sub>3</sub> for adults who practice regular photoprotection (3).

## SUNSCREENS

Currently, the use of sunscreens with broad-spectrum UVB and UVA coverage with minimum sun protection factor (SPF) 30 is recommended, with reapplication at least every two hours and after swimming, perspiring and towel drying. The use of physical measures (shade, clothing, hat) is recommended in all, especially in children younger than six months of age, because of the higher skin surface to body weight ratio and their underdeveloped metabolism. In children younger than six months of age, if absolutely necessary, limited and infrequent use of sunscreen on exposed areas may be done (1).

Correct use, appropriate amount of sunscreen applied and reapplication frequency are important factors for the effectiveness of sunscreens. Concentrations of sunscreen used by consumers (0.5–1 mg/cm<sup>2</sup>), compared with that used in testing

(2 mg/cm<sup>2</sup>) is the reason that in-use SPF frequently is only 20% to 50% of the labeled SPF value. To achieve a 2 mg/cm<sup>2</sup> concentration, the average adult should apply the equivalent of a full 1 oz (30 mL) evenly and liberally to the body (1). Otherwise, two applications of sunscreen, the first 15 to 30 minutes before sun exposure, followed by another application 15 to 30 minutes later, is recommended to obtain adequate amounts of sunscreen on the skin, and to minimize “skip” areas.

Sunscreens are categorized as organic or inorganic, previously also known as chemical or physical, respectively. Organic sunscreens act by absorbing UV radiation, in the UVB, UVA range, or across both spectra. Inorganic filters act by either reflecting or absorbing UV radiation and visible light, depending on the particle size (1).

## ORGANIC UVB FILTERS

SPF is the ratio of the dose of UV radiation (290–400 nm) needed to produce one minimal erythema dose (MED) on sunscreen-protected skin over the dose to needed to produce one MED on unprotected skin, with the concentration of sunscreen used being 2 mg/cm<sup>2</sup> (1,4). Thus, SPF is a reflection of the erythemogenic effect of UV, with is predominantly the biologic effect of UVB, and to a lesser extend, UVA2. To clearly distinguish this protective effect against erythema from the protective effect against the effect of UVA, in August 2007, the FDA proposed to change the acronym SPF to UVB sunburn protection factor (5).

FDA approved UVB sunscreen drugs include paraaminobenzoic acid (PABA), padimate O, octinoxate, cinoxate, octisalate, homosalate, trolamine salicylate, octocrylene and enzulizole.

*PABA*, was previously the most commonly reported contact and photoallergen in sunscreens. Although PABA is an effective sunscreen with maximum peak absorption at 283 nm, concerns of in vitro carcinogenicity with unclear biologic or clinical significance, and the inconvenience of staining of clothes have limited its use.

*Padimate O*, the most commonly used PABA derivate, has a good safety profile and maximum peak absorption at 311 nm.

*Octinoxate* has maximum peak absorption at 311 nm as well, and it is less potent and more photolabile than padimate O. It is the most widely used UVB sunscreen drug in the United States. However, it is photolabile, therefore, the final product requires additional photostable UVB drugs, or stabilizers, to achieve a high SPF value. Its combined use with avobenzene, an excellent but photolabile UVA1 filter, would enhance the photodegradation of both filters.

*Cinoxate* is a less commonly used cinnamate derivative with maximum peak absorption at 289 nm.

*Salicylates* are weak UVB absorbers, therefore, are used in relatively high concentrations to augment the effects of other

UVB absorbers, and to minimize the photodegradation of other sunscreen active ingredients. *Octisalate* has a maximum peak absorption at 307 nm, and *homosalate* has a maximum peak absorption at 306 nm. *Trolamine salicylate* has an absorption range from 260 to 355 nm. While most sunscreen drugs are oil soluble, trolamine salicylate is water soluble; when combined with other sunscreen drugs, it may improve the cosmetical acceptability of the final product by contributing to a lighter, less oily feel. It is frequently used in hair preparations as a photoprotective agent.

*Octocrylene* is a photostable UVB sunscreen drug with maximum peak absorption at 303 nm. It is often combined with other sunscreen drugs to improve photostability of the final product.

*Ensulizole* is a water-soluble sunscreen drug with maximum peak absorption at 310 nm. It is used to enhance the SPF (1), and also to improve the cosmetical acceptability of the final product (6).

Other UVB sunscreen actives approved for use in Europe and other countries but not currently approved by the FDA include discussed next.

*Camphor derivatives* are moderately effective UVB absorbers with a maximum peak absorption at 300 nm (1).

*Univinil T 150* (ethylhexyl triazone), is a UVB sunscreen active with peak absorption at 314 nm. It is composed of a chromophore of PABA linked to a triazine ring. It was considered to be the best UVB sunscreen active before the introduction of *Uvasorb HEB* (diethylhexyl butamido triazone), which has maximum peak absorption at 312 nm, slight improvement in efficacy and increased solubility compared with *Univinil T 150*.

*Parsol SLX* (benzylidene malonate polysiloxane) is a UVB sunscreen active with maximum peak absorption at 312 nm and very large molecular weight (7) (more than 6000 d) (8). *Parsol SLX* does not penetrate the skin surface, resulting in improved safety; however, it has very low UV absorbing properties. It is generally used in combination with other products, resulting in a broad-spectrum photostable sunscreen (7).

## ORGANIC UVA FILTERS

FDA approved organic UVA sunscreen drugs listed in the 1999 sunscreen monograph include oxybenzone, sulizobenzene, dioxybenzone, avobenzone and meradimate. In addition, the FDA recently approved sunscreen products containing ecamsule (terephthalidene dicamphor sulfonic acid, Mexoryl SX).

*Oxybenzone*, *sulizobenzene*, and *dioxybenzone* have two maximum absorption (the UVB and UVA2) ranges, respectively: oxybenzone at 288 and 325 nm, sulizobenzene at 286 and 324 nm, and dioxybenzone at 284 and 327 nm, respectively (8). *Avobenzone* has strong absorption in the UVA1 range, with maximum peak absorbance at 357 nm (8). *Meradimate* absorbs primarily in the UVA2 range, with maximum peak absorption at 340 nm (1). *Ecamsule* is an intrinsically photostable sunscreen drug that absorbs UV radiation between 290 and 390 nm with a maximum peak absorption at 345 nm (7).

While avobenzone is currently considered the best long-wavelength UVA1 sunscreen drug product available in the United States, it is photolabile, therefore, it is frequently combined with other sunscreens or stabilizers to increase its photostability (1). In fact, photostable and broad-spectrum UVB/UVA coverage, is achieved by combining avobenzone (long UVA sunscreen drug) with photostable UVB sunscreen drugs (such as homosalate, octisalate, and octocrylene) and photostable short

UVA sunscreen drugs (such as oxybenzone and ecamsule). In some products, non-UV-filter stabilizers, such as diethylhexyl 2,6-naphthalate (DEHN) are also used.

Other broad-spectrum and intrinsically photostable UVB and UVA sunscreen actives, not yet available in the United States, are described next.

*Silatriazole* (drometriazole trisiloxane, Mexoryl XL) (7) is a photostable UVB and UVA sunscreen active with two absorption spectra in the UVB and UVA range (290–320 nm, maximum absorption peak at 303 nm; and 320–360 nm, maximum absorption peak at 344 nm, respectively) (1,16).

*Bisotrizole* (methylene-bis-benzotriazolyl tetramethylbutylphenol, Tinosorb M) is a photostable UVB and UVA sunscreen active with two maximum absorption peaks at 305 and 360 nm. It is the first class of sunscreens with both organic and inorganic properties; it consists of microfine particles that not only absorb UV but also scatter and reflect it. The particles are dispersed in water phase allowing for synergistic effects with oil-soluble sunscreen actives (7).

*Bemotrizinol* (anizotriazine, bis-ethylhexyloxyphenol methoxyphenol triazine, Tinosorb S) (7) is a photostable UVA and UVB sunscreen active with maximum peak absorption at 310 and 343 nm. Both bisotrizole and bemotrizinol are undergoing the the FDA TEA approval process (1,16).

*Bisdilulizole disodium* (disodium phenyl dibenzimidazole tetrasulfonate, DPDT, Neo Heliopan AT) is a water-soluble UVA sunscreen active with maximum peak absorption at 334 nm. *Diethylamino hydroxybenzoyl hexyl benzoate* (DHHB, Uvinil A plus) has maximum peak absorption at 354 nm and was launched as a successor of avobenzone because of its similar absorptive properties but superior photostability (7).

With the exception of Uvinil A plus, all these new generation sunscreen products have molecular weight over 500 d, hence minimizing the possibility of percutaneous absorption.

A study by Vielhaber et al. assessed the efficacy of five different filters with different absorption maxima in the UVA1 range on their capacity to protect against UVA1-induced matrix metalloproteinase-1 expression on primary human fibroblasts cultures. The efficacy to protect against UVA1-induced matrix metalloproteinase-1 expression was wavelength dependent. UVA filters with maximum absorption at or more than 360 nm were most effective in preventing UVA1-induced matrix metalloproteinase-1 expression, IL-1 $\alpha$  and IL-6 expression, illustrating the critical role of effective UVA1 filtering for protection against photoaging and collagen degradation. The best protection was achieved by experimental filters HRH22127, followed by experimental filter HRH21328, diethylamino hydroxybenzoyl hexyl benzoate, avobenzone and anizotriazine (22).

Currently, there is no uniform method of UVA rating in the United States. For the first time, the 2007 amendment to the 1999 FDA sunscreen monograph proposes a new grading system of the level of UVA protection, comprised of a four-star rating system that ranges from low, medium, high to highest UVA protection. The rating system is based on both in vivo and in vitro testing procedures.

The persistent pigment darkening test is proposed by the FDA as the standard method of in vivo UVA testing, defined as the ratio of the minimal pigmentation dose in sunscreen-protected skin to the minimal pigmentation dose in unprotected skin, evaluated between 3 and 24 hours after the irradiation (5).

Since UVA2 is the portion of UVA mostly represented in the PPD testing (9), the FDA proposed an in vitro testing that



provides a measure of UVA1 protection, specifically, the ratio of UVA1 absorbance to total UV (290–400 nm) absorbance.

When discordances between *in vitro* and *in vivo* test results occur, the final rating will be the lowest rating determined by either of these two methods.

A recent study evaluated the degree of UVA protection provided by 13 popular sunscreen products that are commercially available in the United States, *in vitro*, using the new method proposed by FDA on the 2007 amendment to the sunscreen monograph, as well as using two European/U.K. standardized indices of UVA protection for comparison. On the basis of the new FDA-proposed guidelines, eight products achieved the medium protection category, and five products achieved high protection; nine products achieved the desired critical wavelength value of 370 or higher. No products achieved highest protection. A higher degree of UVA protection was provided by sunscreens with avobenzone photostabilized with octocrylene. This study demonstrates the importance of a grading system and the need to photostabilize avobenzone (10).

## INORGANIC FILTERS

Although inorganic filters act by reflection and absorption, they are less efficient UV absorbers than organic UV filters. Furthermore, thick coating is required to achieve a satisfactory degree of reflection. Decreasing the particle size results in less scattering of visible light, and shifts the protection toward shorter wavelengths and toward absorbency function while improving cosmetic acceptability.

Microfine titanium dioxide has better protection in the UVB and UVA2 range, compared with the UVA1 spectrum. Microfine zinc oxide protects from the UVB to the UVA1 range (1,4).

Protection against visible light, which may be of value in certain photosensitivity conditions, patients undergoing photodynamic therapy and patients with undesired pigmentation, is challenging. Opaque inorganic sunscreens may protect against visible light. Iron oxide is a third physical blocker, not approved in the United States that has shown to confer protection in the visible light range at different concentrations (11).

## Shade

Shade reduces solar irradiation by 50% to 95% (4).

## Clothing

Recent advances in clothing photoprotection have included specifically designed clothing with UV protection factor (UPF), the measurement of UV photoprotection of fabrics, measured *in vitro* with a spectrophotometer that determines the transmission of UVA and UVB through fabrics (4). UPF is regulated by standards, such as the Australian/New Zealand, U.K., European, and U.S. standards (12).

Several factors affect the UPF of fabrics, such as the construction and the color of fabrics, hydration, washing and wearing, chemical treatments, stretching and distance of the fabric from the skin (1,12).

Construction of fabrics, or in other words, how close together the fibers are, is an important factor. Clothing with tightly woven fibers (wool and synthetic materials such as polyester) and thick fibers have higher UPF. Therefore, photoprotective clothing with specific UPF is ideal, since typical summer clothing with loosely woven and thin fabrics provide low UPF. For example, cotton T-shirts provide UPF of 5 to 9, and when wet, the UPF decreases to only 3 to 4.

The UPF decreases considerably when fabrics are stretched. On the other hand, washing shrinks the fabrics and reduces the gaps between fibers. Optical brightening agents are compounds which absorb the incoming visible light photons and convert them into fluoresce, leading to reduced UV transmission and the appearance of being bright. Furthermore, dark-colored fabrics have greater UPF and visible light absorption than light colored fabrics. The laundry additive containing UV absorber Tinosorb FD has been shown to result in significantly increased UPF than fabrics exposed regular washing.

Another factor that affects the UPF of fabrics is the distance of the fabric from the skin. The closer to the skin, the less photoprotection the fabric provides because there is less diffusion of the UV beam reaching the skin (1).

## Hats

Photoprotection of hats varies with the brim width, material and weaving. Narrow-brimmed hats (<2.5 cm) provide SPF 1.5 for nose, and little protection for chin and neck; medium-brimmed hats (2.5–7.5 cm) provide SPF 3 for nose, 2 for cheek and neck, and none for chin. A wide-brimmed hat (>7.5 cm) has SPF 7 for nose, 3 for cheek, 5 for neck, and 2 for chin (1).

## Sunglasses

The cornea absorbs wavelengths below 295 nm, the crystalline lens between 295 and 400 nm and the retina between 400 and 1400 nm, thus visible and infrared light are transmitted to the retina. The ideal sunglass should substantially reduce UV transmission to cornea and lens, including that from lateral directions (thus should wrap around the eyes maximizing eye and eyelid protection). Additional retinal protection can be accomplished with lenses that reduce the transmission of short-wavelength violet/blue light since this portion of visible light is considered to be hazardous to the retina. For added photoprotection, a wide-brimmed hat is recommended to reduce the level of radiation reaching the eyes. Polarizing lenses reduce glare but do not add UV-blocking properties.

Excessively dark tinted sunglasses can cause pupillary dilatation and increase lid opening, thus resulting in increased UV exposure to the lens of the eye. Clear glasses, on the other hand, absorb the vast majority of UVB radiation but no UVA radiation. Therefore, for UVA protection, a plastic film containing zinc, chrome, nickel or other metals with broad-spectrum UV coverage is typically obtained.

Sunglasses standards have been developed to ensure quality, performance and adequate protection to consumers. While in Australia and Europe, standards are mandatory, the U.S. standard is voluntary and not followed by all manufacturers. The U.S. standard (ANZI Z80.3) requires less than 1% of the wavelengths below 310 nm to be transmitted.

Sunglasses have been classified in three categories: special purpose sunglasses (which are indicated for specific activities such as skiing and going to the beach), general purpose (which reduce the glare of bright light) and cosmetic (which provide minimal UV protection) (13).

## Makeup

Foundation makeup without sunscreen provides SPF of 3 to 4 because of its pigment content for up to four hours after application. For better protection, foundations containing UV filters with high SPF (1) and adequate UVA coverage are of greater value.

**Table 26.1** Types of Window Glasses

Type of glass	Characteristics
Clear glass	Transparent. Transmits 90% of visible light, 72% UV (300–380 nm), and up to 83% of solar infrared irradiation.
Tinted or heat-absorbing glass	Reduces unwanted heat gain and UV and visible light transmission in comparison with clear glass.
Reflective glass	Reduces solar heat gain, UV radiation, and visible light transmission to less than 20%. Often used in commercial buildings.
Low-emissivity glass	Reduces solar heat gain and interior generated heat loss without the loss of color neutrality. Allows >70% of visible light transmission. Different coatings allow for 20–60% transmission of UV and 40–70% reflection of solar heat. UVA is still transmitted.
Laminated glass	2 pieces of glass together with a plastic interlayer, which is virtually invisible. Filters 99% of UV ( $\leq 380$ nm), reduces the transmission of sound.
UV-blocking-coated glass	Contains a very thin invisible surface, looks indistinguishable from standard clear glass. Monolithic form blocks >98% of UV ( $\leq 380$ nm) while transmitting visible light.
Combined spectrally selective low-emissivity and UV-blocking-coated	Blockage of >99% UV and 70% solar heat gain, maintains 70% visible light transmission. Appears very close to standard clear glass.

Source: Adapted from Ref. 15.

### Sunless Tanning Agents

Although not usually recommended as a photoprotective method, dihydroxy acetone, the active ingredient of sunless tanning preparations has an SPF of 2, and interestingly, has protective properties against UVA and the low end of visible light for approximately five to six days (1,4).

### Window Glass

While *standard glass* filters out UVB but not UVA, visible light and infrared radiation, several types of glass are now available, in which the use of additional filters for UVA and infrared radiation are incorporated, without the historically associated loss of visible light transmission. Different types of specialty glasses are described in Table 26.1.

### Automobile Glass

All car windshields are made of laminated glass, which blocks the vast portion of UVA radiation. Conversely, rear and side windows are usually made from nonlaminated glass that transmits a significant amount of UVA. To reduce the transmission of UVA radiation, visible and infrared light, tints to rear and side windows or complete laminated window glass packages can be added, especially for photosensitive patients (13).

### PUBLIC EDUCATION ON PHOTOPROTECTION

Campaigns educating the public about photoprotective measures have been in place for several years in the United States and different countries. Australia has a well established population-based skin cancer prevention program called SunSmart since 1988, incorporating substantial public education efforts and environmental change strategies. A populational based study indicates that, in nine cross-sectional surveys from 1987 to 2002, in which 11,589 adults were interviewed, and trends over 15 years in behavioral risk factors for skin cancer were examined, there was an increase in use of sunscreen and hats, decreased sunburn incidence, increased preference for no tan, and higher proportion of body surface protected from the sun. Such study highlights that photoprotective programs can be effective in improving a population's photoprotective behaviors (14).

### SKIN CANCER PREVENTION

Cancer chemoprevention is defined as the use of synthetic, natural or biologic chemical agents to prevent, suppress or reverse carcinogenic properties, which thus include the photoprotection measures aforementioned. There have been non-randomized studies and case reports of the use of systemic retinoids, primarily acitretin and isotretinoin in low doses, for the prevention of nonmelanoma skin cancers (NMSCs) development, particularly patients with high risk of skin cancer development. Evidence at this time indicates preventive effect is more pronounced at squamous cell carcinoma (SCC) development, compared with basal cell carcinoma (BCC) development. Because of the known toxicity of retinoids, patient selection for systemic retinoid therapy is essential.

Indications for the use of systemic retinoid therapy are divided into general and specific indications. General indications include patients developing greater than five NMSCs per year; those with multiple NMSCs and actinic keratosis, especially of the head and neck area; patients with aggressive subtypes of NMCs, and patients with metastatic NMSCs and patients with eruptive keratoacanthomas. Specific indications include solid organ transplant recipients, chronically immunosuppressed patients with NMSCs; psoriasis patients treated with PUVA who developed NMSCs, especially SCCs; patients with radiation induced BCCs; human immunodeficiency virus-positive patients with multiple NMSCs; patients with non-Hodgkin's lymphoma or chronic lymphocytic leukemia with NMSCs, patients with xeroderma pigmentosum, nevoid BCC syndrome, Basex's syndrome and Rombo syndrome, and patients with epidermodysplasia verruciformis.

In general, acitretin is considered the first line agent for skin cancer prophylaxis in men and in women not of childbearing potential, low dose therapy is associated with low incidence of adverse effects compared with isotretinoin. On the other hand, isotretinoin is the drug of choice in female patients of childbearing potential, such as patients with XP and nevoid BCC syndrome.

Although the optimal treatment protocol is not clear, gradual escalation dose pattern, starting from a low dose and increasing as tolerated, is the regimen mostly studied. Therefore, acitretin 10 mg/day for four weeks, followed by increase to 20 mg/day for four weeks as tolerated to maintenance dose of 25 mg/day is recommended. For isotretinoin, 0.25 mg/kg/day

for two months, followed by final dose of 0.5 mg/kg/day, is recommended. Ideal duration of therapy is unfortunately not completely clear, it varied between six months to two years in different studies with variable follow up period. Clinical and laboratory monitoring for adverse effects is recommended, as with any other indication of systemic retinoid use (15). It would be interesting to find out if topical retinoid therapy has a chemopreventive effect, as it has been used as an adjuvant for photoaging and actinic keratosis (16).

Photodynamic therapy has also been reported as a means of managing actinic keratosis, BCCs and SCCs in immunosuppressed patients (17).

Considering the morbidity of skin cancer, particularly in high risk groups, chemoprevention with therapeutic agents should be considered. Needless to say, dermatologists do a superb job at proper treatment of actinic keratosis for cancer prevention. Perhaps clinicians, in the proper clinical setting, should have a low threshold for the use of field treatments for actinic keratosis, such as 5-fluoracil, photodynamic therapy, imiquimod and retinoids, which may address clinically unapparent actinic damage.

## PHOTODAMAGE PREVENTION AND TREATMENT WITH ANTIOXIDANTS AND DIETARY AGENTS

UVB can induce DNA damage directly via the formation of cyclobutane pyrimidine dimers (CPDs). Furthermore, UV irradiation triggers the production of short DNA fragments during the course of excision repair process.

One small single stranded DNA fragment, *thymidine dinucleotide*, mimics cellular responses to UV radiation, via activation of p53 and increased messenger RNA levels for the responsible proteins, as demonstrated in human fibroblasts. This results in enhanced melanogenesis, tumor necrosis factor  $\alpha$  expression and secretion, induction of IL-10 expression and increased DNA repair and reversible cell growth arrest (1). Therefore, thymidine dinucleotides may play a role in photoprotection.

*T4 endonuclease V* is a bacterial DNA excision repair enzyme that repairs CPDs in DNA. Both animal and human studies demonstrated removal of CPDs with topical treatment with its liposome form. In addition, its application immediately after UV exposure partially protects against sunburn cell formation, local suppression of contact hypersensitivity, suppression of delayed-type hypersensitivity, and nearly completely prevented UV-induced upregulation of IL-10 and tumor necrosis factor  $\alpha$  messenger RNAs (1). Topical application of *T4 endonuclease V* for one year also lowered the rate of development of actinic keratoses and BCCs in patients with xeroderma pigmentosum (1,18).

*Photolyase* is another DNA repair enzyme that has been reported to decrease the number of UVB-induced dimers by 40% to 45% in human skin when applied immediately after UVB exposure (1), as well as preventing immunosuppression, erythema and sunburn formation (18).

Antioxidants can be used adjunctively with other methods in photoprotection, both orally and topically. Many agents continue to be reported in the literature to have photoprotective properties, usually on a molecular basis. Commonly used antioxidants in sunscreen products include vitamin E and vitamin C. Vitamin D (calcitriol or 1,25-dihydroxyvitamin D<sub>3</sub>), carotenoids, zinc and selenium also have photoprotective properties. The list of antioxidant agents with reported photoprotective properties includes, the daily worldwide used and

flavor admired caffeine, polyphenolic compounds present in green tea, flavonoid cocoa, which are present in beverages; in addition to the antioxidant genistein, present in spices and foods (such as soybean, Greek oregano, Greek sage, *Ginkgo biloba*), caffeic acid and ferulic acid, present in vegetables, as well as  $\omega$ -3 polyunsaturated fatty acid, the commercialized plant extract *Polypodium leucotomos*, *N*-acetylcysteine (a synthetic antioxidant), pomegranate extract, aloe plant poly/oligosaccharide, among many others.

*Green tea* contains four main polyphenolic compounds, (–)-epicatechin (EC), (–)-epicatechin gallate (ECG), (–)-epigallocatechin (EGC), and (–)-epigallocatechin-3-gallate (EGCG). EGCG is considered the main polyphenol responsible for the antioxidant effects. These compounds exhibit anti-inflammatory activity, suppression of contact hypersensitivity (19), as well as effects on photocarcinogenesis, including a decrease tumor burden, inhibition on the formation and size of malignant and nonmalignant tumors and regression of these tumors in mice with established tumors. Effects of green tea polyphenols in photoaging include the inhibition of UVB-induced expression of matrix metalloproteinases and reduction of UVB-induced collagen cross-linking (1).

The antioxidant plant extract *P. leucotomos* is used as a photoprotection agent in patients with photodermatosis, 240 mg twice daily, started 15 days prior to sun exposure (20). Proposed mechanisms include prevention of UV-induced photoisomerization of *trans*-urocanic acid (21), anti-inflammatory properties, prevention of UV-induced apoptosis in human keratinocytes and fibroblasts (22), prevention of photodecomposition of both endogenous photoprotective molecules and DNA, and prevention of UV-induced cell death (23). After topical and oral administration, *P. leucotomos* was reported to increase the UV dose required for IPD, MED, minimal melanogenic dose and minimal phototoxic dose (1).

## SUMMARY

In the past 10 years, significant advances have been made in the understanding of the prevention of photodamage. Behavioral modification in seeking shade, the use of SPF 30 or above sunscreens, the use of photoprotective clothing, wide-brimmed hat and sunglasses are proven to minimize photodamage. Photoprotection should be accompanied by appropriate intake of vitamin D<sub>3</sub> (total of 1000 IU daily). Public education is essential to get the message across to the general population.

## ACKNOWLEDGMENT

Dr Lim and Dr Hexsel have participated in the conception and design, drafting, and critical revision of the chapter for important intellectual content. **Conflict of Interest:** Dr Lim is a consultant for La Roche-Posay, Orfagen, Johnson and Johnson, and Dow Pharmaceuticals; and he has received research grant support from Johnson and Johnson. Dr Hexsel has no conflicts of interest to declare.

## REFERENCES

1. Kullavanijaya P, Lim HW. Photoprotection. *J Am Acad Dermatol* 2005; 52:937–958; quiz 959–962.
2. Bischoff-Ferrari H, Lim HW. Effect of photoprotection on vitamin D and health. In: Lim HW, Draelos ZD, eds. *A Clinical Guide to Sunscreens and Photoprotection*. New York: Informa Healthcare, 2009:117–138.

3. Position statement on vitamin D. Available at: <http://www.aad.org/forms/policies/uploads/ps/ps-vitamin%20d.pdf>. Accessed August 22.
4. Lautenschlager S, Wulf HC, Pittelkow MR. Photoprotection. *Lancet* 2007; 370:528–537.
5. 21 CFR Parts 347 and 352. Sunscreen drug products for over-the-counter human use: proposed amendment of final monograph; proposed rule. *Fed Regist* 2007; 72:49070–49122.
6. Rai R, Srinivas CR. Photoprotection. *Indian J Dermatol Venereol Leprol* 2007; 73:73–79.
7. Tuchinda C, Lim HW, Osterwalder U, et al. Novel emerging sunscreen technologies. *Dermatol Clin* 2006; 24:105–117.
8. Shaath N. *The Encyclopedia of Ultraviolet Filters*. Carol Stream: Allured Publishing Corporation, 2007:222.
9. Bissonnette R, Allas S, Moyal D, et al. Comparison of UVA protection afforded by high sun protection factor sunscreens. *J Am Acad Dermatol* 2000; 43:1036–1038.
10. Wang SQ, Stanfield JW, Osterwalder U. In vitro assessments of UVA protection by popular sunscreens available in the United States. *J Am Acad Dermatol* 2008; 59:934–942.
11. Bissonnette R. Update on sunscreens. *Skin Therapy Lett* 2008; 13:5–7.
12. Gies P. Photoprotection by clothing. *Photodermatol Photoimmunol Photomed* 2007; 23:264–274.
13. Tuchinda C, Srivannaboon S, Lim HW. Photoprotection by window glass, automobile glass, and sunglasses. *J Am Acad Dermatol* 2006; 54:845–854.
14. Dobbins SJ, Wakefield MA, Jansen KM, et al. Weekend sun protection and sunburn in Australia trends (1987–2002) and association with SunSmart television advertising. *Am J Prev Med* 2008; 34:94–101.
15. Lens M, Medenica L. Systemic retinoids in chemoprevention of non-melanoma skin cancer. *Expert Opin Pharmacother* 2008; 9: 1363–1374.
16. Peck GL. Topical tretinoin in actinic keratosis and basal cell carcinoma. *J Am Acad Dermatol* 1986; 15:829–835.
17. Braathen LR, Szeimies RM, Basset-Seguín N, et al. Guidelines on the use of photodynamic therapy for nonmelanoma skin cancer: an international consensus. *International Society for Photodynamic Therapy in Dermatology*, 2005. *J Am Acad Dermatol* 2007; 56:125–143.
18. Verschooten L, Claeherhout S, Van Laethem A, et al. New strategies of photoprotection. *Photochem Photobiol* 2006; 82:1016–1023.
19. Afaq F, Mukhtar H. Botanical antioxidants in the prevention of photocarcinogenesis and photoaging. *Exp Dermatol* 2006; 15: 678–684.
20. Caccialanza M, Percivalle S, Piccinno R, et al. Photoprotective activity of oral *Polypodium leucotomos* extract in 25 patients with idiopathic photodermatoses. *Photodermatol Photoimmunol Photomed* 2007; 23:46–47.
21. Capote R, Alonso-Lebrero JL, Garcia F, et al. *Polypodium leucotomos* extract inhibits trans-urocanic acid photoisomerization and photodecomposition. *J Photochem Photobiol B* 2006; 82:173–179.
22. Alonso-Lebrero JL, Dominguez-Jimenez C, Tejedor R, et al. Photoprotective properties of a hydrophilic extract of the fern *Polypodium leucotomos* on human skin cells. *J Photochem Photobiol B* 2003; 70:31–37.
23. Gonzalez S, Alonso-Lebrero JL, Del Rio R, et al. *Polypodium leucotomos* extract: a nutraceutical with photoprotective properties. *Drugs Today (Barc)* 2007; 43:475–485.

## Photodamage: protection and reversal with topical antioxidants

Karen E Burke

### INTRODUCTION

More than ever before, our generation enjoys the luxury of travel and leisure time for outdoor sports, markedly increasing our exposure to solar ultraviolet (UV) radiation. Exposure is increased at high altitudes and with reflection from surfaces covered with snow, sand, water or concrete. Our skin suffers the greatest damage—both acutely, with erythema and sunburn, and chronically, resulting in photoaging with mottled pigmentation, wrinkling, dryness, and keratoses as well as the severe consequence of skin cancer.

Certainly, sunscreens are essential for protection, but they are not enough. The most significant inherent limitations are inadequate application (too little, too infrequently) and incomplete spectral protection from both UVA and UVB radiations. The skin naturally uses nutritional antioxidants to protect itself from photodamage, and when effective formulations are applied topically, sun protection is enhanced.

Topical application of these antioxidants can give far higher concentrations in the skin than even maximal oral intake. The challenge is to make formulations that are *stable* and that give *effective transcutaneous absorption* to deliver effectively *high concentrations of the active forms* to the dermis as well as the epidermis.

This chapter describes the necessary concentrations, molecular forms, and requirements for stability and topical delivery of several antioxidants that have been proven to be effective: vitamin C, vitamin E, and selenium. New research on topical application of genistein (a soy isoflavone) is also presented.

### VITAMIN C

Vitamin C (L-ascorbic acid) is the body's major aqueous-phase antioxidant and is vital for life. All animals make their own vitamin C, except for humans and other primates, one species of Indian fruit-eating bat, and the guinea pig. In fact, a 59-kg goat synthesizes 13 g of vitamin C per day, almost 200 times the American Food and Drug Administration (FDA) requirement (1). Not only do other animals make hundreds of times the vitamin C we ingest, but also, when under stress, they can make more than 10 times their normal amount of vitamin C. Unfortunately, we humans do not have that capability (1).

Our skin is the organ that suffers most from environmental free-radical stress from exposure to sunlight, pollution, and smoking. This contact, furthermore, depletes the level of vitamin C in the skin. Even minimal UV exposure of 1.6 minimal erythema dose (MED) decreases the level of vitamin C to 70% of the normal level, and exposure to 10 MED decreases the vitamin C to only 54% (2). Exposure to 10 parts per million of

ozone in city pollution decreases the level of epidermal vitamin C by 55% (3).

That was the bad news. The good news is that the most effective way to increase the skin level of vitamin C significantly is by topical application. Topical absorption was proven to be effective by radioactive labeling studies in pigs. After treatment with 10% vitamin C cream, 8.2% was found in the dermis, and 0.7% was in the blood (4). Formulations containing 5%, 10%, 15%, 20%, or 25% vitamin C were tested. After 24 hours, 20% resulted in the highest skin levels, with maximized concentration in the skin after three days (5). Topical vitamin C protects against solar damage primarily as an antioxidant that deactivates the UV-induced free radicals. Vitamin C is itself not at all a sunscreen, although applying vitamin C decreases the degree of redness and sunburn suffered even when applied after sun exposure. Protection is confirmed by histologic examination. Treatment with topical 10% vitamin C decreases the number of abnormal "sunburn cells" by 40% to 60% (4) and reduces the UV damage to DNA by 62% (4).

Topical vitamin C is also directly anti-inflammatory. Laser resurfacing causes redness for at least three to four months. With vitamin C applied before and after laser surgery, redness is decreased after only two months (6). Topical vitamin C can also be used effectively to treat the inflammation of rosacea (7).

The main action of vitamin C on the skin is direct stimulation of collagen synthesis. Vitamin C is an essential cofactor for the two enzymes required for collagen synthesis: prolyl hydroxylase (which makes the collagen molecule stable) and lysyl hydroxylase (which cross-links the collagen to give structural strength) (8). Recent research has further demonstrated that vitamin C acts directly on DNA to increase the transcription rate and to stabilize the procollagen mRNA, thus regulating and maintaining the intercellular amount of collagen (9).

Exciting experiments have demonstrated that vitamin C also has antiaging effects. Studies *in vitro* compared newborn with elderly (80–95 year old) fibroblasts (10). Elderly cells proliferate *in vitro* at only one-fifth of the rate of newborn cells. However, when vitamin C is added to the culture medium, the elderly cells proliferate better than normal newborn fibroblasts. Even the newborn fibroblasts proliferate almost four times better when exposed to vitamin C (10).

Not only do fibroblasts increase proliferation in the presence of vitamin C, but they also synthesize more collagen. Newborn fibroblasts synthesize a larger percentage of collagen than elderly cells, but again, when elderly cells are exposed to vitamin C *in vitro*, they produce more collagen than the normal newborn fibroblasts (10). Surprisingly, even the newborn cells double the amount of collagen synthesized (10).



**Figure 27.1** Correction of photoaging after one year of once-daily treatment with 15% vitamin C Serum (SkinCeuticals). Notice the improvement of periorbital wrinkles and lightening of solar lentigines. *Source:* Courtesy of SkinCeuticals, Dallas, TX, USA.

Vitamin C further reverses the adverse appearance of photoaging by inhibiting tyrosinase (11), thereby fading unattractive solar lentigines. Because L-ascorbic acid may inhibit elastin biosynthesis (12), it may reduce the solar elastosis of photoaged skin.

The remarkable reversal of photoaging can be appreciated in Figure 27.1. After one year of once-daily treatment with 15% topical vitamin C, wrinkles were clearly reduced and mottled pigmentation resolved in both of the subjects shown. The skin acquired a healthy, more youthful glow.

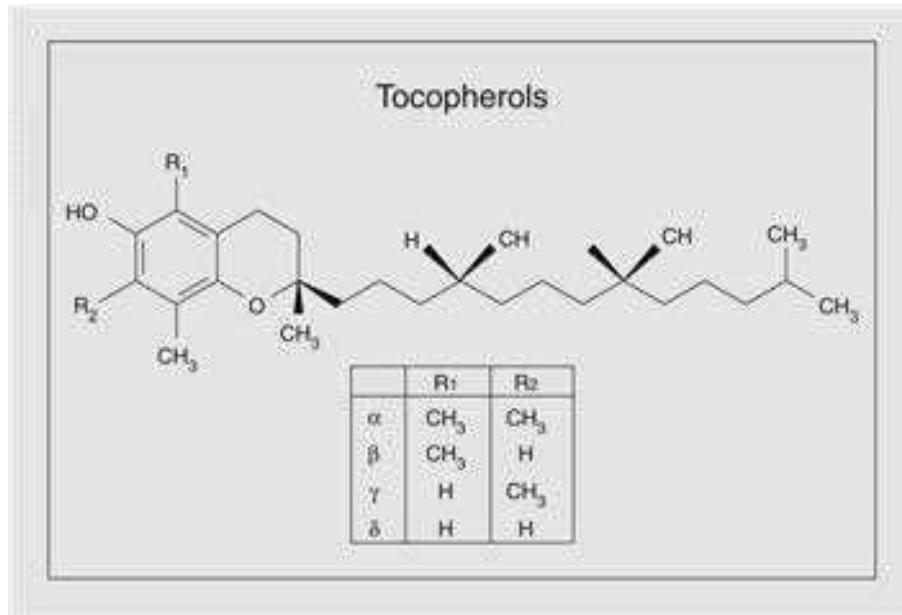
Another important action of vitamin C on the skin is that topical vitamin C increases the synthesis of several specific lipids of the skin surface (13). This means that not only does vitamin C help the natural moisturization of the skin but also enhances the protective barrier function of the skin (14).

To optimize percutaneous absorption and full activity of vitamin C, the precise formulation is of the utmost importance (15). Since L-ascorbic acid is an inherently unstable molecule—making it an excellent antioxidant—creation of an effective topical delivery system is crucial. Many products contain stable derivatives that are not metabolized by the skin (such as ascorbyl-6-palmitate or magnesium ascorbyl phosphate) and therefore have no activity (5). Other formulations do not result in measurable absorption of vitamin C because they are not at the correct pH. Delivery of L-ascorbic acid ( $pK_a = 4.2$ ) depends on removing the ionic charge—achieved optimally at a pH of 3.5 (5). As stated above, the most effective concentration for topical delivery is 20%, giving maximal skin levels after three days.

## VITAMIN E

Natural vitamin E is the most important lipid-soluble, membrane-bound antioxidant in the body. Vitamin E is especially abundant in the stratum corneum, delivered there by sebum (16,17). Its concentration is highest at the lower levels of the stratum corneum, with a decreasing gradient outward. As the outermost defense of the body, the stratum corneum is first to absorb the oxidative stress of sunlight and pollution. Vitamin E is depleted in the process, so topical application can be particularly advantageous, especially since the lipophilic structure makes it cosmetically attractive for application and absorption.

Several forms of vitamin E exist in natural dietary sources. The form that is found in mammalian tissues and which has by far the greatest biologic activity is pure, nonesterified RRR- $\alpha$ -tocopherol (or D- $\alpha$ -tocopherol) (18,19), which has three methyl groups on the 6-chromal ring (Fig. 27.2). Humans use predominantly  $\alpha$ -tocopherol because a specific  $\alpha$ -tocopherol transfer protein selectively transfers  $\alpha$ -tocopherol into lipoproteins (20). The other natural forms are  $\beta$ ,  $\gamma$ , and  $\delta$  that contain only one or two methyl groups on the 6-chromal ring. Relative to the  $\alpha$  form, the  $\beta$ ,  $\gamma$ , and  $\delta$  RRR-tocopherols give only 42%, 72%, and 40%, respectively, of the protection against post-UV edema (21). The synthetic form is “dl” or “all-*rac*,” a mixture of eight stereoisomers. The synthetic isomers are esterified (to acetates and succinates) for use in commercial vitamins and some topical formulations because the esters are far more stable. This ester must be hydrolyzed before there is any biologic activity, a reaction that readily occurs in the stomach after oral ingestion or in cell and organ culture, but is very slow after topical application.



**Figure 27.2** Molecular structures of tocopherols.



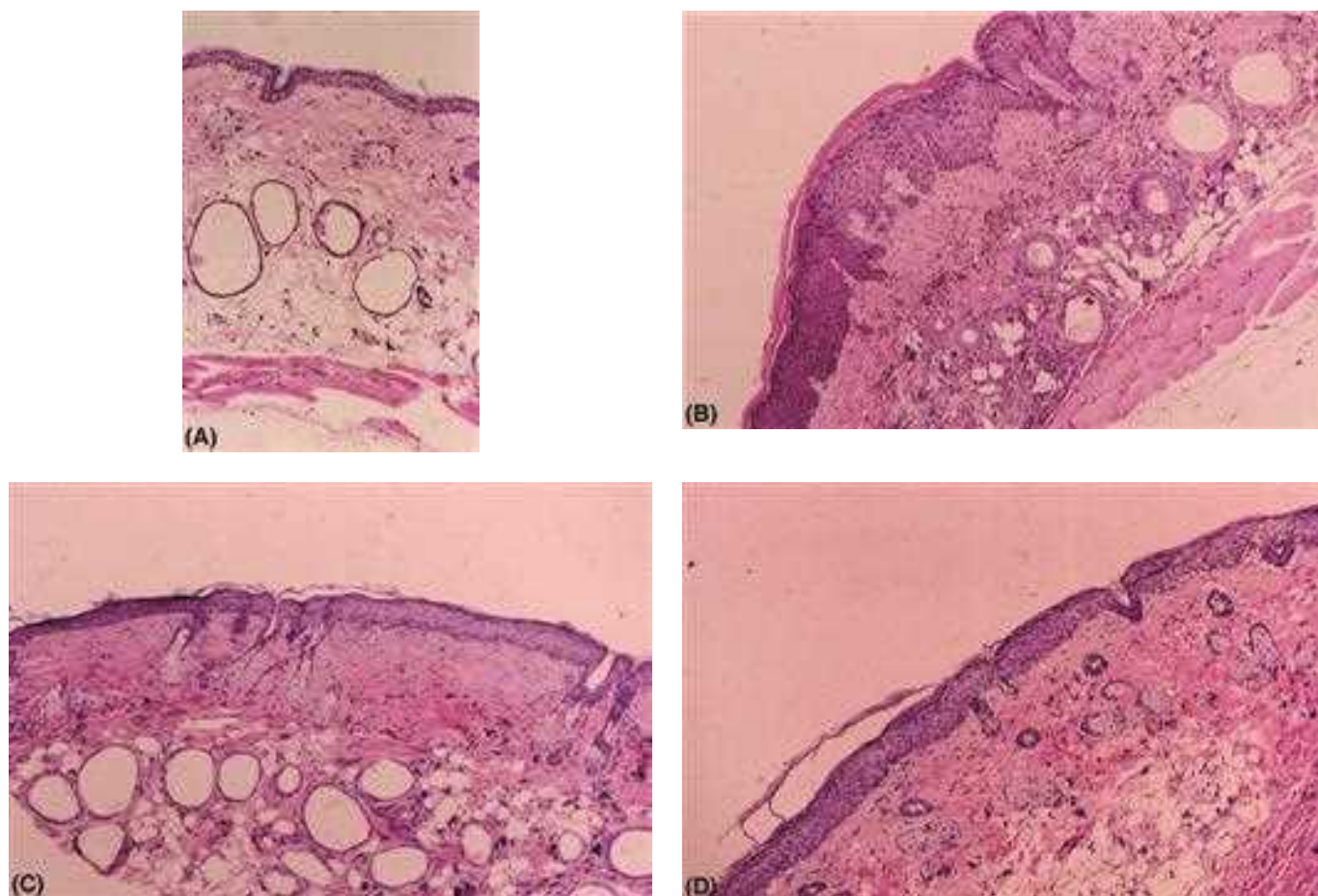
**Figure 27.3** Correction of periorbital wrinkles after four months of once-daily treatment with 0.05% D- $\alpha$ -tocopherol cream.

The skin has only a limited capacity to cleave the esterified forms of vitamin E to the active free tocopherol form, so the antioxidant potential of the esters is minimal (22,23). Furthermore, the all-*rac* form of vitamin E has been reported to cause allergic contact dermatitis (24) and erythema multiforme (25) when applied topically. No such adverse reaction has been reported with D- $\alpha$ -tocopherol.

Previous studies have demonstrated protection from the acute (26–32) UV-induced damage of inflammation (erythema, “sunburn”) and hyperpigmentation (tanning) as well as protection from the chronic UV-induced damage of skin cancer (31–36) even by the various forms of vitamin E that are less metabolically potent when applied topically than the nonesterified Eol. Topical D- $\alpha$ -tocopherol was shown to be far more effective in protecting against all acute and chronic UV-induced damage than topical D- $\alpha$ -tocopheryl succinate in mice (37). In other mouse studies, topical  $\alpha$ -tocopheryl succinate and  $\alpha$ -tocopheryl acetate not only failed to inhibit UVB-induced

immunosuppression and carcinogenesis but also appeared to enhance carcinogenesis (22). Topical  $\alpha$ -tocopheryl acetate was less effective than  $\alpha$ -tocopherol in protecting against UV-induced erythema in rabbits (22,38) and against UV-induced photoaging in mice (39).

Vitamin E has been demonstrated to reverse photoaging dramatically. Figure 27.3 shows the impressive decrease in periorbital rhytides in a 48-year-old woman after four months of daily application of D- $\alpha$ -tocopherol (5%). This correction of UV-induced damage was confirmed by histologic examination. Mice were exposed to UVB for six weeks, after which epidermal hypertrophy with thickened stratum corneum, an increased incidence of damaged “sunburn cells” in the basal layer, disruption of dermal collagen and degradation of dermal elastin, and dermal inflammation were noted, as shown in Figure 27.4. Each group was then treated for eight weeks with vehicle cream, 0.05% retinoic acid, 5% D- $\alpha$ -tocopherol cream, or 0.05% L-selenomethionine cream (see following



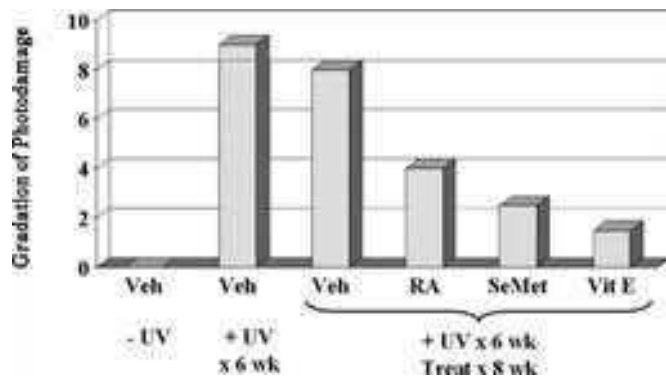
**Figure 27.4** Histologic correction of photodamage by topical antioxidants. Four groups of 10 Skh:2 mice were exposed to UVB three days per week for six weeks to photodamage the skin. Then each group was treated five days per week for eight weeks as follows: (i) vehicle, (ii) 0.05% retinoic acid, (iii) 5.0% D- $\alpha$ -tocopherol, (iv) 0.05% L-selenomethionine. (A) Biopsies taken before UVB exposure show a thin, outer keratin layer, normal epidermis, normally aligned, fine fibrillar dermal collagen and elastin, and no dermal inflammation. (B) Biopsies after UV exposure show a markedly thickened keratin layer, epidermal hypertrophy, degradation of dermal collagen and elastin, and prominent dermal inflammation. After treatment for six weeks with (C) topical 0.05% retinoic acid or (D) topical 5.0% D- $\alpha$ -tocopherol, there is reversal of hyperkeratosis and epidermal hypertrophy and repair of damaged dermal collagen and elastin with clearing of dermal inflammation. (Special stains for collagen and elastin are not shown.)

section), after which multiple biopsies from each mouse were evaluated (blind) by two experienced dermatopathologists. The histologic improvement in all parameters of photoaging can be appreciated in Figure 27.4, with a marked decrease in hyperkeratosis and epidermal hypertrophy, repair of damaged dermal collagen and elastin, and clearing of dermal inflammation after treatment with retinoic acid or with vitamin E. Each of these parameters was graded on a scale of 0 (no damage) to 4 (maximal damage). As shown in Figure 27.5, in overall gradation, D- $\alpha$ -tocopherol cream was even more effective at reversing UV-induced damage than retinoic acid, the “gold-standard” of topical antiaging formulations (KE Burke et al., unpublished observation). Further electron microscopic analysis confirmed correction of collagen and elastin fiber damage and demonstrated repair of UV-induced disruption of the basement membrane anchoring fibrils.

### VITAMIN C WITH VITAMIN E

As presented earlier, the skin uses predominantly vitamin C to protect the aqueous environment and vitamin E to protect membranes from lipid peroxidation. Since vitamin C is naturally present intracellularly in relatively high concentrations, L-ascorbic acid not only acts directly as an antioxidant and as an essential cofactor in the synthesis of collagen, but also regenerates oxidized membrane vitamin E, so that the vitamin E need not be replaced (40). Oral vitamin C with E in high doses protects against UV-induced erythema in humans (41,42), whereas either vitamin alone is ineffective (42). Topical L-ascorbic acid (15%) with D- $\alpha$ -tocopherol (1%) gives four-fold protection against UV-induced erythema and thiamine dimer formation in porcine skin (43). This protection from UV-induced erythema (44) and tanning (45) by vitamins C and E combined with melatonin was further demonstrated in





**Figure 27.5** Gradation of histologic correction of photodamage by topical antioxidants. Each of four histological parameters for photodamage (hyperkeratosis, epidermal thickness, collagen disruption, and solar elastosis) was graded on a scale of 0 (no damage) to 4 (maximal damage) and evaluated before exposure to UVB, after exposure to UVB, and after treatment for eight weeks with vehicle (veh), 0.05% retinoic acid (RA), 0.05% L-selenomethionine (SeMet), or 5.0% D- $\alpha$ -tocopherol (vit E). The average gradation of all parameters of damage is shown. *Source:* From Ref. 83.

humans. Fortunately, mixing these hydrophilic and lipophilic antioxidants in a topical formulation stabilizes each (43) for a cosmetically attractive application.

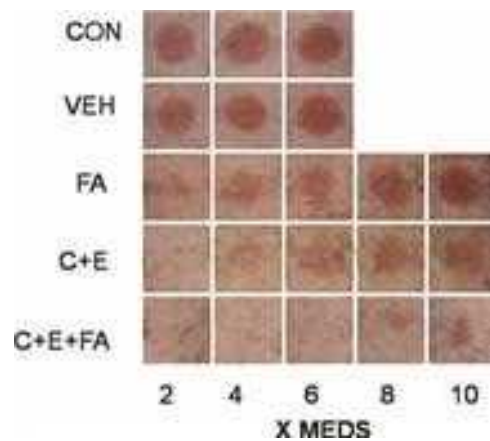
### VITAMIN C WITH VITAMIN E AND FERULIC ACID

Ferulic acid is found ubiquitously and at high concentrations in plants (46–48) where it cross-links polysaccharides and proteins during lignin cell wall synthesis (49). A potent antioxidant, ferulic acid protects membranes from lipid peroxidation and neutralizes alkoxy and peroxy radicals. It has also been shown to have synergistic interactions with ascorbic acid (50). Furthermore, ferulic acid itself minimally blocks UVB to give some sunscreen protection (Fig. 27.6).

After testing the effectiveness of a series of low molecular weight antioxidants that are available in chemically pure form, Zielinski and Pinnell et al. (51) demonstrated that ferulic acid provides stability of more than 90% for L-ascorbic acid and 100% for  $\alpha$ -tocopherol. Addition of ferulic acid (optimally 0.5%) to the formulation of vitamin C (15%) + vitamin E (1%) doubles photoprotection to solar-simulated irradiation of skin from fourfold to approximately eightfold as measured by both erythema (as shown in Fig. 27.6) and sunburn cell formation (52,53). Enhanced photoprotection was further demonstrated immunohistochemically by inhibition of UV-induced formation of thymine dimer mutations and of UV-induced p53, both of which are associated with skin cancer. Evaluation by real-time polymerase chain reaction demonstrated suppression of UV-induced cytokine mRNA formation (for inflammatory cytokines interleukin (IL)-1 $\alpha$ , IL-6, IL-8, and tumor necrosis factor (TNF)- $\alpha$ , as well as for the immunosuppressive cytokine IL-10) (53).

### VITAMIN C WITH FERULIC ACID AND PHLORETIN

Phloretin is another potent plant-derived phenolic antioxidant (found in both the flesh and peel of apples) that can be absorbed by the skin. When combined with vitamin C and



**Figure 27.6** Photoprotection by topical antioxidant formulations. Skin was (i) untreated or pretreated with (ii) vehicle, (iii) 0.5% ferulic acid, (iv) 15% vitamin C + 1% vitamin E, or (v) 15% vitamin C + 1% vitamin E + 0.5% ferulic acid and irradiated with solar-simulated radiation [2 $\times$  to 10 $\times$  minimal erythema dose (MED)]. Visual erythema one day later is shown. *Source:* From Ref. 52.

ferulic acid, phloretin enhances photoprotection to UVA-induced erythema and pigmentation (54). Biopsies from human volunteers after UV exposure (89% UVA and 11% UVB) and treatment with a formulation containing vitamin C (10%), ferulic acid (0.5%), and phloretin (2.0%) at pH 2.5, demonstrated significant photoprotection as measured by decreased thymine dimer formation, decreased matrix metalloproteinase-9 expression, and decreased p53 expression (54). This topical serum also protected against UV-induced immunosuppression: There was no UV-induced decrease in CD1a-expressing Langerhans cells when skin was pretreated with vitamin C + ferulic acid + phloretin (54).

### SELENIUM

Selenium, an essential trace element in humans and animals, is required by the intracellular antioxidant enzymes glutathione peroxidase and thioredoxin reductase (55,56). Selenium has been shown to have other protective effects that may not involve selenium-dependent glutathione peroxidase activity (57), such as protecting (58) and repairing DNA (59,60), reducing the DNA binding of carcinogens (61), inhibiting neoplastic transformation (62), and suppressing gene mutations at the lysine and histidine loci (63).

Selenium has been implicated in reducing carcinogenesis. In animal tumor models, moderate selenium supplementation at levels above the dietary requirements decreases the number of tumors induced by several chemical carcinogens (64) and viruses (65), and reduces the incidence of spontaneous mammary tumors (66). In addition, selenium supplements inhibit the growth of human tumor cell lines *in vitro* (67) as well as the growth of transplanted tumors in mice (68,69), and decrease the mutagenic activity of several known carcinogens (70,71).

Some, but not all, epidemiological studies have found a reduced risk for several kinds of cancers associated with a higher blood concentration of selenium (72–74). A decreased selenium concentration and glutathione peroxidase activity



**Figure 27.7** Correction of periorbital wrinkles after four months of once-daily treatment with 0.05% L-selenomethionine lotion.

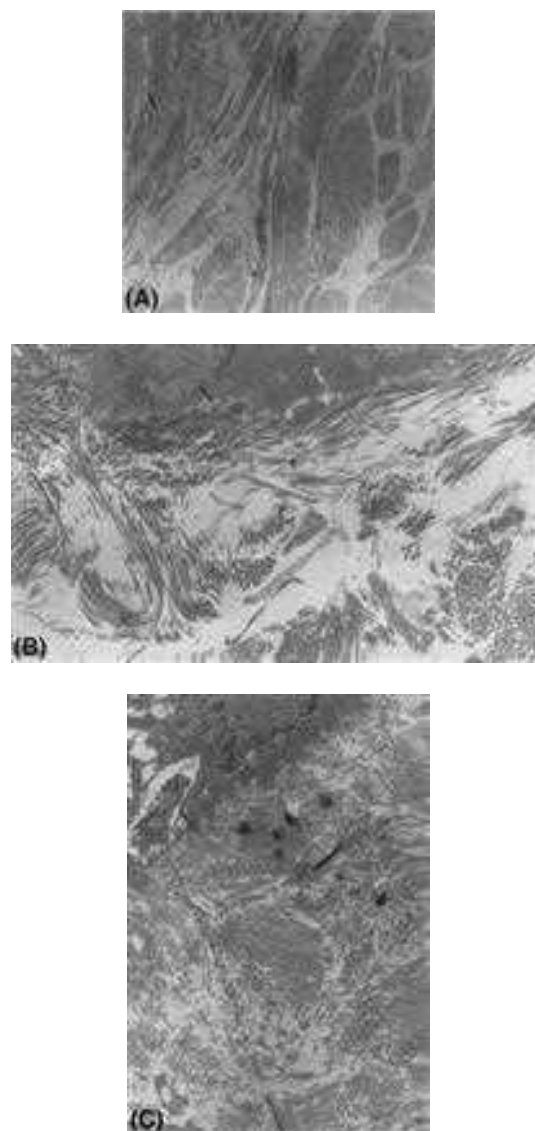
in blood and, interestingly, an increase of these parameters in malignant tissue was found in lung cancer patients (74). A study of 240 nonmelanoma skin cancer patients in good general health demonstrated a significantly lower mean plasma selenium concentration than control subjects without skin cancer (75). In fact, those patients whose blood concentrations were in the lower decile had 4.4 times the incidence of skin cancer as those in the highest decile (75).

In a 10-year prospective study of 1312 patients with a history of basal cell or squamous cell carcinomas of the skin, selenium treatment did not protect against further development of such skin cancers; however, it did reduce total cancer incidence and the incidence of lung, colorectal, and prostate cancer as well as lung cancer mortality (76). The lack of protection against skin cancer may indicate that selenium cannot enhance rates of repair of previously incurred damage, so it cannot protect patients whose skin is already severely oncogenically damaged from prior UVB exposure.

Topical preparations containing selenium sulfide are frequently used for the treatment of tinea versicolor (77), seborrheic dermatitis (78), and dandruff (79). However, the selenium from these preparations is not absorbed by the skin (79). Selenium can be absorbed transdermally in guinea pigs when applied as selenomethionine (80), giving increased skin and liver levels of selenium after topical application of 0.02% selenomethionine to mice (81). This formulation increased the MED in humans (82) and decreased UV-induced skin damage, as demonstrated by a decrease in post-UV tanning and skin cancer in Skh:2 mice (81).

Topical L-selenomethionine is highly effective not only in preventing but also in reversing photoaging (83). The significant decrease in periorbital rhytides in a 56-year-old woman after four months of daily application of L-selenomethionine (0.05%) is seen in Figure 27.7.

This correction of UV-induced damage was similar to that of topical vitamin E as discussed previously and confirmed by histologic examination as shown (for topical vitamin E) in Figure 27.4. All histologic parameters of photodamage demonstrated reversal after treatment with topical L-selenomethionine (83). Transmission electron microscopy further confirmed repair of dermal photoaging, as shown in Figure 27.8 (83). Normal, non-UV-damaged dermis (Fig. 27.8A) consists of dense collagen with homogeneous bundles of uniformly dispersed fibers aligned parallel to the basal lamina above. The dermal-epidermal junction shows anchoring fibrils of dense collagen. After exposure to UV (Fig. 27.8B), the dermal collagen is sparse; bundles are not uniform and are irregularly



**Figure 27.8** Reversal of photodamage by topical antioxidants: Transmission electron microscopy. (A) Before UV exposure, (B) after six weeks of UVB exposure, (C) after treatment for eight weeks of UVB-exposed skin with topical 0.05% L-selenomethionine. Source: From Ref. 83.

dispersed; fibers are disoriented and fragmented. There is an increase in extracellular mucopolysaccharide matrix. The dermal-epidermal junction has sparse collagen with a decrease in anchoring fibrils. Treatment with topical L-selenomethionine did indeed reverse this UV-induced damage (Fig. 27.8C): Dermal collagen was repaired and fibers became oriented and more regular. As collagen became denser, the increase in extracellular mucopolysaccharide matrix resolved. Collagen was replaced in the dermal-epidermal junction with repair of the anchoring fibrils. Clearly topical L-selenomethionine is effective in reversing photodamage of the skin (83).

## SELENIUM WITH VITAMIN E

In many biologic systems, vitamin E and selenium often act synergistically. Borek et al. (84) demonstrated that selenium and RRR- $\alpha$ -tocopheryl succinate (natural vitamin E succinate) act alone by different mechanisms to prevent radiogenic and chemically induced transformation in vitro. They further showed that there was additive protection when both were used together (84).

In experiments in mice comparing and combining topical L-selenomethionine with topical D- $\alpha$ -tocopherol (85), the topical combination was less effective than topical vitamin E alone—both in prolonging the onset and in decreasing the incidence of UV-induced skin cancers (85).

However, topical L-selenomethionine with oral vitamin E was more effective than either alone. Both forms of vitamin E alone were equally effective and more effective than topical L-selenomethionine alone (85).

Topical L-selenomethionine (alone or in combination with each form of vitamin E) was most effective in preventing UV-induced inflammation (100% effective!) (85). In reducing UV-induced pigmentation, topical L-selenomethionine with topical or with oral vitamin E was more effective than any one of these antioxidants alone, particularly during the first eight weeks of UV exposure.

## GENISTEIN

Recent epidemiologic analysis comparing Asian diets high in soy (average daily intakes of 20–150 mg) (86) with American diets (average daily intake of only 1–3 mg) (86) indicate that soy confers major health benefits by decreasing the incidence of cancer (86–89) and reducing cardiovascular disease (87). Since genistein is the most plentiful isoflavone in soy, this molecule has been the most extensively studied component for its chemopreventive and anticancer effects.

Extensive experimental evidence documents the direct anticarcinogenic action of genistein. Animal studies demonstrate protection against bladder, breast, colon, liver, lung, prostate, and skin cancer (86,90) with oral genistein. Growth of many in vitro cancer cell lines is inhibited by genistein (90). Dietary soy inhibits chemically induced skin cancer in mice (91). Exciting research demonstrates that genistein arrests the growth and induces the differentiation of malignant melanoma in vitro (92) and inhibits pulmonary metastases of melanoma in vivo (93,94).

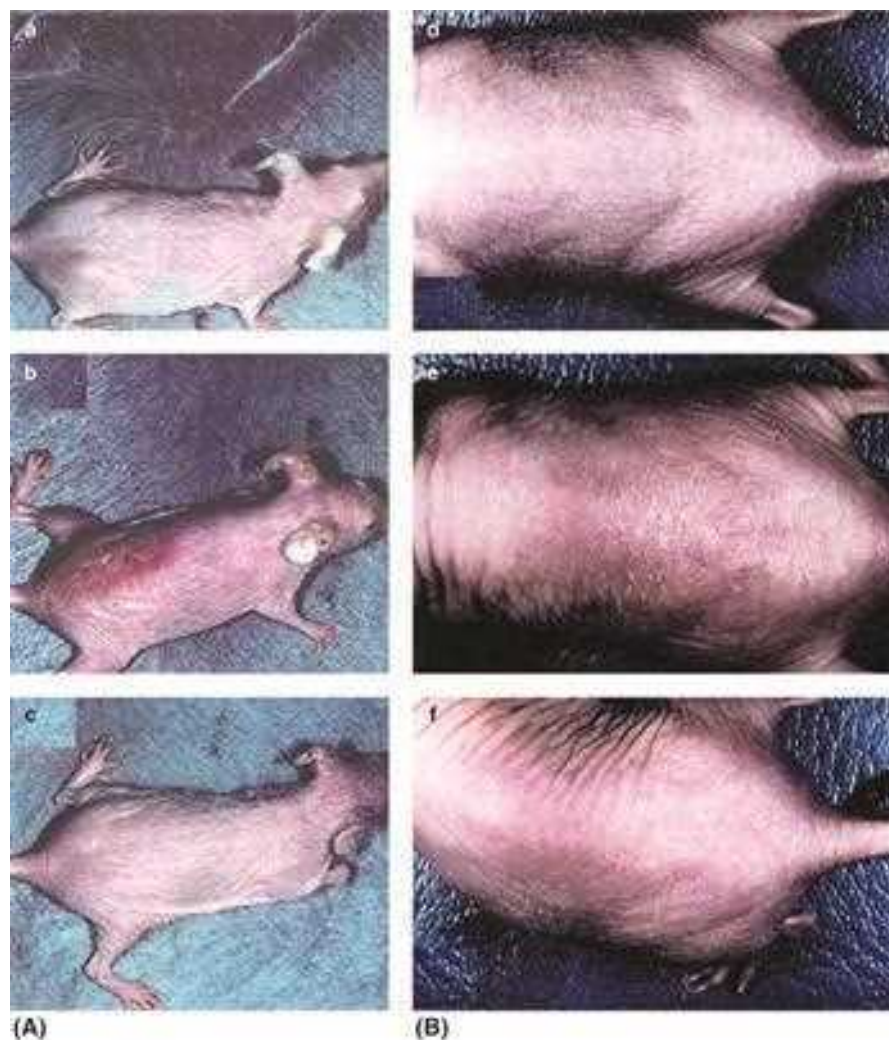
The mechanism by which genistein inhibits carcinogenesis may be through its proven inhibition of tyrosine protein kinases (TPKs), the enzymes that phosphorylate proteins necessary for regulation of cell division and transformation (95). Of particular importance is phosphorylation of TPK-dependent

epidermal growth factor receptors (EGF-R) that are related to tumor promotion, including initiation of transcription factors, release of inflammatory mediators (such as prostaglandins), and stimulation of cell proliferation (96). Genistein was found to downregulate both UVA- and UVB-induced EGF-R phosphorylation in human epidermoid carcinoma cells in vitro (97). By similar enzymic inhibition, genistein retard UV-induced apoptotic changes, including caspase-3 and p21-activated kinase 2 activation of human epidermal carcinoma cells (98) and phosphokinase C $\delta$  in human keratinocytes (99).

Genistein is also a potent antioxidant. Genistein scavenges peroxyl free radicals, thereby protecting against lipid peroxidation in vitro (100) and in vivo (101). The decreased incidence of cardiovascular disease with high soy diets may be due to genistein's inhibiting the oxidation of low-density lipoprotein (LDL) cholesterol in both aqueous and lipophilic environments. Of direct importance in protection of the skin from UV-induced damage, genistein has been shown to inhibit in vitro UV-induced DNA oxidation (102) and cellular DNA oxidation induced by benzopyrene and UVA (103) and by phorbol ester stimulation (104), as well as by psoralen plus UVA (PUVA) therapy (105). The fact that genistein also reduces erythema and histologic inflammation induced by PUVA in mouse skin (106) may have important implications for PUVA therapy, by reducing possible short- and long-term adverse reactions.

The use of topical genistein to prevent and reverse photoaging has recently been intensively investigated, with promising results. In animal studies, Wei et al. (97) demonstrated that topical genistein (10  $\mu$ mol/cm<sup>2</sup>) protects against acute and chronic UV damage to the skin. After exposure of Skh:1 hairless mice to UVB, topical genistein completely blocked acute skin burns and inhibited UVB-induced cutaneous wrinkling (as seen clinically in Fig. 27.9) (97). This protection from UV-induced erythema with topical genistein (0.5%) was further confirmed in pig skin by an increase in MED and a decrease in number of sunburn cells after pretreatment with topical genistein (107). Histologic analysis in mice showed that topical genistein substantially blocked the signs of chronic photodamage: epidermal hyperplasia and reactive acanthosis with nuclear atypia (97). At a molecular level, UV-induced damage to DNA as measured by the biomarker 8-hydroxydeoxyguanosine was markedly reduced (108). Protection was also demonstrated by decreased expression of proliferating cell nuclear antigen (PCNA) (a marker of DNA repair that indirectly indicates degree of UV damage) as well as by decreased cox-2 expression and by increased catalase concentration in mice treated with topical genistein (1–3 mg/mL) prior to UVB exposure (109). Inhibition of acute UV-induced erythema with topical genistein was also demonstrated in humans. Topical genistein (5  $\mu$ mol/cm<sup>2</sup>) (applied 30 minutes before UVB radiation) inhibited, by one MED, the UVB-induced erythema (97). Further recent immunohistologic studies on human reconstructed skin demonstrated that pretreatment with genistein (10–50  $\mu$ M) inhibits UV-induced DNA damage, as measured by inhibition of pyrimidine dimer formation and of expression of PCNA (110). The degree of protection is dose dependent, increasing with increasing concentrations of genistein (110).

Equally impressive is the fact that topical genistein also inhibits the most serious consequence of chronic UVB damage: skin cancer. Both the incidence and the multiplicity of UVB-induced skin tumors in Skh:2 hairless mice were reduced by about 90% after 25 weeks of UVB exposure (97). Furthermore, after induction of skin tumors in mice by



**Figure 27.9** (A) Effect of genistein on ultraviolet B (UVB)-induced acute skin burns. Once daily for 10 days, Skh:1 hairless mice were treated with 5  $\mu\text{mol}$  of genistein 60 minutes before UVB irradiation ( $1.8 \text{ kJ/m}^2$ ). Photographs were taken 24 hours after final UVB irradiation. (a) Negative (sham) control; (b) vehicle + UVB; (c) 5  $\mu\text{mol}$  of genistein + UVB. (B) Effect of genistein on photodamage in mouse skin chronically exposed to UVB. Twice weekly for 20 weeks, Skh:1 hairless mice were treated topically with 5  $\mu\text{mol}$  of genistein 60 minutes before or 5 minutes after UVB irradiation ( $0.3 \text{ kJ/m}^2$ ). (d) Negative (sham) control; (e) vehicle + UVB; (f) UVB + genistein.

7,12-dimethylbenzanthracene (DMBA) and promotion by 12-*O*-tetradecanoylphorbol-13-acetate (TPA), topical genistein (10  $\mu\text{M}$ ) inhibited tumor numbers by 60% to 75% (108).

To investigate the mechanism of inhibition of UV-induced skin cancer, the effect of genistein on the expression of the photo-oncogenes *c-fos* and *c-jun* on mRNA was investigated in mouse skin (111). Expression of these proteins induces matrix metalloproteinases that degrade dermal connective tissue, causing the wrinkles and laxity of photoaging (112). Overexpression of these photo-oncogenes is related to promotion of cell proliferation in oncogenesis. At low-dose UVB, genistein (20  $\mu\text{M}$ ) substantially inhibited both; at high dose, genistein blocked *c-fos* but had little effect on *c-jun* (111). Treatment of mouse skin immediately after UVB irradiation also inhibited the expression of both (111). In human skin, topical genistein (1%) did prevent UV-induced *c-jun*, thereby preventing photoaging and oncogenesis (112).

Another possible dermatologic benefit of genistein is as a phytoestrogen. The skin has both  $\alpha$  and  $\beta$  nuclear estrogen receptors (ER) (113), through which estrogen binding can regulate linked genes of proliferation and differentiation. Genistein has a 30-fold higher affinity for ER $\beta$  than ER $\alpha$  (114), but a greater ER $\alpha$  agonist activity than ER $\beta$  (115). Although estradiol has 700-fold more ER $\alpha$  and 45-fold more ER $\beta$  activity than genistein, the possible biologic effect of genistein (even through dietary soy isoflavones) may be great. Oral (116,117) and topical (118,119) estrogen increases the collagen content of skin, which diminishes with aging, and especially dramatically in women during and after menopause (120). Genistein may reduce the "crepey" appearance of aging skin by stimulating collagen synthesis. Indeed, genistein does increase collagen gene expression in fibroblasts *in vitro* (121).

In other studies on normal human fibroblasts exposed to chemical oxidative stress, genistein prevented disturbances in

**Table 27.1** Correction of Photoaging with Topical Estrogens

	$\beta$ -Estradiol (0.01%)	Genistein (4%)
↑ Epidermal thickness	75%	20%
↑ Number of dermal papillae	135%	0%
↑ Fibroblasts	123%	0%
↑ Blood vessels	77%	36%

Biopsies of preauricular skin were taken before and after topical gel treatment once/day for 24 weeks and analyzed by image digitalization. Source: From Ref. 124.

the insulin-like growth factor-1 receptor-mediated collagen signaling pathway (122). Also, treatment of cultured human dermal fibroblasts with soy extract increased synthesis of collagen and hyaluronan (123). Topical application of a soy extract emulsion ameliorated UV-induced flattening of the dermoepidermal junction and enhanced the number of dermal papillae, thus demonstrating histologically rejuvenation of photoaged human skin (123). Armed with these auspicious *in vitro* and *in vivo* studies, a six-month study of postmenopausal women compared topical  $\beta$ -estradiol (0.01%) with topical genistein (4%) (124). Skin biopsies showed that topical estrogens gave more correction of photodamage than did genistein, as summarized in Table 27.1.

Thus, topical genistein shows great promise not only in protection of the skin against extrinsic acute and chronic UV photodamage, but also in enhancing collagen synthesis, which is diminished with normal intrinsic aging.

## SUMMARY

There are two great advantages to applying an active formulation (5) of topical antioxidant(s) to the skin. First, the skin attains far higher levels of each antioxidant than can be achieved by only taking these supplements orally (5). For example, the level of vitamin C attained in the skin by topical application is 20 to 40 times the level achievable with oral vitamin C (5); with topical application, the concentration of vitamin E increases by a factor of 10.6 (37) and selenium by a factor of 1.7 (81). Second, topical application arms the skin with a reservoir of antioxidant(s) that cannot be washed or rubbed off, a protection that stays in the skin for several days after application (5). Because topical antioxidants work by affecting cellular mechanisms of photoprotection, they supplement sunscreens in preventing photoaging and skin cancer. Indeed, scientific research confirms that topical application of antioxidant(s) offers exciting new possibilities not only in *protecting* the skin from UV damage (to reduce extrinsic photoaging and to retard intrinsic aging) but also in *reversing* previously incurred photodamage.

## REFERENCES

- Pauling L. How to Live Longer and Feel Better. New York: WH Freeman, 1987.
- Shindo Y, Wit E, Han D, et al. Dose response effects of acute ultraviolet irradiation on antioxidants and molecular markers of oxidation in murine epidermis and dermis. *J Invest Dermatol* 1994; 23:470-475.
- Thiele JJ, Traber MG, Tsang KG, et al. *In vivo* exposure to ozone depletes vitamins C and E and induces lipid peroxidation in epidermal layers of murine skin. *Free Radic Biol Med* 1997; 23:85-91.
- Darr D, Combs S, Dunsten S, et al. Topical vitamin C protects porcine skin from ultraviolet radiation-induced damage. *Br J Dermatol* 1992; 127:247-253.
- Pinnell SR, Yang HS, Omar M, et al. Topical L-ascorbic acid: percutaneous absorption studies. *Dermatol Surg* 2001; 27:137-142.
- Alster T, West TB. Effect of vitamin C on postoperative CO<sub>2</sub> laser resurfacing erythema. *Dermatol Surg* 1998; 24:331-334.
- Bergfeld W, Pinnell S. Topical vitamin C. *Dialogues Dermatol Am Acad Dermatol* 1996; 38:1.
- Kivirikko KI, Myllyla R. Post-translational processing of procollagens. *Ann N Y Acad Sci* 1985; 460:187-201.
- Tajima S, Pinnell SR. Ascorbic acid preferentially enhances types I and III collagen gene transcription in human skin fibroblasts. *J Dermatol Sci* 1996; 11:250-253.
- Phillips CL, Combs SB, Pinnell SR. Effects of ascorbic acid on proliferation and collagen synthesis in relation to donor age of human dermal fibroblasts. *J Invest Dermatol* 1994; 103:228-232.
- Maeda K, Fukuda M. Arbutin: mechanism of its depigmenting action in human melanocyte culture. *J Pharmacol Exp Ther* 1996; 276:765-769.
- Davidson JM, Luvalle PA, Zoia O, et al. Ascorbate differentially regulates elastin and collagen biosynthesis in vascular smooth muscle cells and skin fibroblasts by pretranslational mechanisms. *J Biol Chem* 1997; 272:345-352.
- Uchida Y, Behne M, Quec D, et al. Vitamin C stimulates sphingolipid production and markers of barrier formation in submerged human keratinocyte cultures. *J Invest Dermatol* 2001; 117:1307-1313.
- Catiel-Higournenc Ferrais C, Guey C, Schmidt R, et al. Private communications: L'Oréal Advanced Research Laboratories, Clichy and Aulnay-sous-Bois, France.
- Pinnell SR, Madey DL. The benefits of topical vitamin C (L-ascorbic acid) for skin care and UV protection. *Aesth Surg J* 1998; 18:126-134.
- Podda M, Weber C, Traber MG, et al. Simultaneous determination of tissue tocopherols, tocotrienols, ubiquinol, and ubiquinones. *J Lipid Res* 1996; 37:893-901.
- Thiele JJ. Oxidative targets in the stratum corneum: a new basis for antioxidative strategies. *Skin Pharmacol Appl Skin Physiol* 2001; 14:87-91.
- Mayer P, Pittermann W, Wallat S. The effects of vitamin E on the skin. *Cosmet Toiletries* 1993; 108:99-109.
- Burton GW, Traber MG, Acuff RV, et al. Human plasma and tissue  $\alpha$ -tocopherol concentrations in response to supplementation with deuterated natural and synthetic vitamin E. *Am J Clin Nutr* 1998; 67:669-684.
- Azzi A, Breyer I, Feher M, et al. Specific cellular responses to  $\alpha$ -tocopherol. *J Nutr* 2000; 131(suppl):369-375.
- Potokar M, Holtmann W, Werner-Busse A. Effectiveness of vitamin E protecting against UV light—comparative testing of the natural tocopherols on the skin of the hairless mouse. *Fat Sci Technol* 1990; 92:406-410.
- Gensler HL, Aickin M, Peng YM, et al. Importance of the form of topical vitamin E for prevention of photocarcinogenesis. *Nutr Cancer* 1996; 26:183-191.
- Beijersbergen van Hanegouwe GMJ, Junginger HE, de Vries H. Hydrolysis of RRR- $\alpha$ -tocopheryl acetate (vitamin E acetate) in the skin and its UV protecting activity (an *in vivo* study with the rat). *J Photochem Photobiol B Biol* 1995; 29:45-51.
- Hart M. Vitamin E: a contact sensitizer. *Schoch Lett* 1990; 40:48.
- Saperstein H, Rapaport M, Rietschel RL. Topical vitamin E as a cause of erythema multiforme-like eruption. *Arch Dermatol* 1984; 120:906-908.
- Möller H, Potokar M, Wallat S. Vitamin E also Kosmetischer Wirkstoff. *Parfüm Kosmet* 1987; 68:688-708.
- Potapenko A, Abijev G, Pistosov M, et al. PUVA-induced erythema and changes in mechano-electrical properties of skin inhibition by tocopherols. *Arch Dermatol Res* 1984; 276:12-16.

28. Moeller H, Ansmann A, Wallat S. The effects of vitamin E on the skin in topical applications. *Fett-Wissenschaft Technol* 1989; 8:295-315.
29. Trevithick J, Xiong H, Lee S, et al. Topical tocopherol acetate reduces post-UVB, sunburn-associated erythema, edema and skin sensitivity in hairless mice. *Arch Biochem Biophys* 1992; 296:575-582.
30. Record IR, Dreosti IE, Konstantinopoulos M, et al. The Influence of topical and systemic vitamin E on ultraviolet light-induced skin damage in hairless mice. *Nutr Cancer* 1991; 16:219-225.
31. Marenus K, Muizzuddin N, Kasman K, et al. The use of antioxidants in providing protection from chronic suberythemal UV-B exposure. 16th IFSCC Conference 1990; 1:24-34.
32. Berton TR, Conti CJ, Mitchell DL, et al. The effect of vitamin E acetate on ultraviolet-induced mouse skin carcinogenesis. *Mol Carcinog* 1998; 23:175-184.
33. Black H, Lenger W, McCann V, et al. Relation of UV dose to antioxidant modification of photocarcinogenesis. *J Am Coll Toxicol* 1983; 2:201-207.
34. Bissett D, Chatterjee R, Hannon D. Protective effect of a topically applied antioxidant plus an anti-inflammatory agent against ultraviolet radiation-induced chronic skin damage in the hairless mouse. *J Soc Cosmet Chem* 1992; 43:85-92.
35. Gensler H, Magdaleno M. Topical vitamin E inhibition of immunosuppression and tumorigenesis induced by ultraviolet irradiation. *Nutr Cancer* 1991; 15:97-106.
36. Gerrish K, Gensler H. Prevention of photocarcinogenesis by dietary vitamin E. *Nutr Cancer* 1993; 19:125-133.
37. Burke KE, Clive J, Combs GF Jr., et al. The effects of topical and oral vitamin E on pigmentation and skin cancer induced by ultraviolet irradiation in Skh:2 hairless mice. *Nutr Cancer* 2000; 38:87-97.
38. Roshchupkin D, Pistsov MY, Potapenko AY. Inhibition of ultraviolet light-induced erythema by antioxidants. *Arch Dermatol Res* 1979; 266:91-94.
39. Bissett DL, Chatterjee R, Hannon DP. Photoprotective effect of superoxide-scavenging antioxidants against ultraviolet radiation-induced chronic skin damage in the hairless mouse. *Photodermatol Photoimmunol Photomed* 1990; 7:56-62.
40. Chan AC. Partners in defense, vitamin E and vitamin C. *Can J Physiol Pharmacol* 1993; 71:725-731.
41. Eberlein-Konig B, Placzek M, Przybilla B. Protective effect against sunburn of combined systemic ascorbic acid (vitamin C) and d- $\alpha$ -tocopherol (vitamin E). *J Am Acad Dermatol* 1998; 38:45-48.
42. Fuchs J, Kern H. Modulation of UV-light-induced skin inflammation by d- $\alpha$ -tocopherol and L-ascorbic acid: a clinical study using solar simulated radiation. *Free Radic Biol Med* 1998; 25:1006-1012.
43. Lin J, Selim A, Shea C, et al. UV photoprotection by combination topical antioxidants vitamin C and E. *J Am Acad Dermatol* 2003; 48:866-874.
44. Dreher F, Gabard B, Schwindt DA, et al. Topical melatonin in combination with vitamins E and C protects skin from ultraviolet-induced erythema: a human study in vivo. *Br J Dermatol* 1998; 139:332-339.
45. Quevedo WC, Holstein TJ, Dyckman J, et al. The responses of the human epidermal melanocyte system to chronic erythematous doses of UVR in skin protected by topical applications of a combination of vitamins C and E. *Pigment Cell Res* 2000; 13:190-192.
46. Graf E. Antioxidant potential of ferulic acid. *Free Radic Biol Med* 1992; 13:435-448.
47. Rice-Evans CA, Miller NJ, Paganga G. Structure-antioxidant activity relationships of flavonoids and phenolic acids. *Free Radic Biol Med* 1996; 20:933-956.
48. Ou S, Kwok K-C. Ferulic acid: Pharmaceutical functions preparation and applications in foods. *J Sci Food Agric* 2004; 84:1261-1269.
49. Mathew S, Abraham TE. Ferulic acid: an antioxidant found naturally in plant cell walls and feruloyl esterases involved in its release and their applications. *Crit Rev Biotechnol* 2004; 24: 59-83.
50. Trombino S, Serini S, Di Nicuolo F, et al. Antioxidant effect of ferulic acid in isolated membranes and intact cells: Synergistic interactions with alpha-tocopherol, beta-carotene, and ascorbic acid. *J Agric Food Chem* 2004; 52:2411-2420.
51. Zielinski JE, Pinnell SR. Stabilized ascorbic acid compositions and methods thereof. US Patent 34405.2, 2004.
52. Lin F-H, Lin J-Y, Gupta RD, et al. Ferulic acid stabilizes a solution of vitamins C and E and doubles its photoprotection of skin. *J Invest Dermatol* 2005; 125:826-832.
53. Murray JC, Burch JA, Streilein RD, et al. A topical antioxidant solution containing vitamins C and E stabilized by ferulic acid provides protection for human skin against damage caused by ultraviolet irradiation. *J Am Acad Dermatol* 2008; 59:418-425.
54. Oresajo C, Stephens T, Hino PD, et al. Protective effects of a topical antioxidant mixture containing vitamin C, ferulic acid, and phloretin against ultraviolet-induced photodamage in human skin. *J Cosmet Dermatol* 2008; 7:290-297.
55. Stadtman TC. Mammalian selenoenzymes. *Ann N Y Acad Sci* 2000; 894:399-402.
56. Barceloux DG. Selenium. *Clin Toxicol* 1999; 37:145-172.
57. Ragman MP. The importance of selenium to human health. *Lancet* 2000; 356:233-241.
58. Roussyn I, Briviba K, Masumolo H, et al. Selenium-containing compounds protect DNA from single-strand breaks caused by peroxyxynitrite. *Arch Biochem Biophys* 1996; 330:218-220.
59. Lawson T, Birt DF. Enhancement of the repair of carcinogen-induced DNA damage in the hamster pancreas by dietary selenium. *Chem Biol Interact* 1983; 45:95-104.
60. Russell GR, Nader CJ, Patrich EJ. Induction of DNA repair by some selenium compounds. *Cancer Lett* 1980; 10:75-80.
61. Chen T, Goelchius MP, Combs GF, et al. Effects of dietary selenium and vitamin E on covalent binding of aflatoxin to chick liver cell macromolecules. *J Nutr* 1982; 112:350-355.
62. Chatterjee M, Banerjee MR. Influence of selenium (Se) and beta-carotene on transformation of mammary cells in culture of the whole mammary organs of BALB:c mice (abstr). *Proc Am Assoc Cancer Res* 1983; 23:349.
63. Rosin MP. Effects of sodium selenite on the frequency of spontaneous mutation of yeast mutator strains (abstr). *Proc Am Assoc Cancer Res* 1981; 22:55.
64. Combs GF Jr. Selenium. In: Micozzi MS, Moon TE, eds. *Nutrition and Cancer Prevention*. New York: Marcel Dekker, 1989:389-420.
65. Milner JA. Effects of selenium on virally induced and transplantable tumor models. *Fed Proc* 1985; 44:2568-2572.
66. Schrauzer GN, McGinness JE, Kuehn K. Effects of temporary selenium supplementation on the genesis of spontaneous mammary tumors in inbred female C3H/St mice. *Carcinogenesis* 1980; 1:199-201.
67. Redman C, Scott JA, Baines AT, et al. Inhibitory effect of selenomethionine on the growth of three selected human tumor cell lines. *Cancer Lett* 1998; 125:103-110.
68. Greeder GA, Miller JA. Factors influencing the inhibitory effect of selenium on mice inoculated with Erlich ascites tumor cells. *Science* 1980; 209:825-827.
69. Ip C. Prophylaxis of mammary neoplasia by selenium supplementation in the initiation and promotion phases of chemical carcinogenesis. *Cancer Res* 1981; 41:4386-4390.
70. Shamberger RJ, Beaman KD, Corlett CL, et al. Effect of selenium and other antioxidants on the mutagenicity of malonaldehyde (abstr). *Fed Proc* 1978; 37:261.
71. Jacobs MM, Matney TS, Griffin AC. Inhibitory effects of selenium on the mutagenicity of 2 acetylaminofluorene (AAF) and AAF derivatives. *Cancer Lett* 1977; 2:319-322.
72. Willett WC, Stampfer MJ. Selenium and cancer. *Br Med J* 1988; 297:573-574.
73. Kabuto M, Imai H, Yonezawa C, et al. Prediagnostic serum selenium and zinc levels and subsequent risk of lung and

- stomach cancer in Japan. *Cancer Epidemiol Biomarkers Prev* 1994; 3:465-469.
74. Zachara BA, Marchaluk-Wisniewaka E, Maciag A, et al. Decreased selenium concentration and glutathione peroxidase activity in blood and increase of these parameters in malignant tissue of lung cancer patients. *Lung* 1997; 175:321-332.
  75. Clark LC, Graham GF, Crainse RG, et al. Plasma selenium and skin neoplasms: a case-control study. *Nutr Cancer* 1984; 6:13-21.
  76. Clark LC, Combs GF, Turnbull BW, et al. Effects of selenium supplementation for cancer prevention in patients with carcinoma of the skin. *J Am Med Assoc* 1996; 276:1057-1063.
  77. Faergemann JU, Fredriksson T. Tinea versicolor: some new aspects on etiology, pathogenesis and treatment. *Int J Dermatol* 1982; 1:8-11.
  78. Bereston ES. Use of selenium sulfide shampoo in seborrheic dermatitis. *J Am Med Assoc* 1954; 157:1246-1247.
  79. Cummins LM, Kimuka ET. Safety evaluation of selenium sulfide antidandruff shampoos. *Toxicol Appl Pharmacol* 1971; 20:89-96.
  80. Edwards LI. The absorption of methionine by the skin of the guinea pig. *Biochemistry* 1954; 57:542-547.
  81. Burke KE, Combs GF, Gross EG, et al. The effects of topical and oral L-selenomethionine on pigmentation and skin cancer induced by ultraviolet irradiation. *Nutr Cancer* 1992; 17:123-137.
  82. Burke KE, Bedford RG, Combs GF Jr., et al. The effect of topical L-selenomethionine on minimal erythema dose of ultraviolet irradiation in humans. *Photodermatol Photoimmun Photomed* 1992; 9:52-57.
  83. Burke KE. Method for the prevention and reversal of the extrinsic aging of the skin by transdermal application of selenamino acids and compositions therefore. US Patent no. 5,330,757, July 19, 1994.
  84. Borek C, Ong A, Mason H, et al. Selenium and vitamin E inhibit radiogenic and chemically induced transformation in vitro via different mechanisms. *Proc Natl Acad Sci* 1986; 83:1490-1494.
  85. Burke KE, Clive J, Combs GF, et al. The effects of topical L-selenomethionine with topical and oral vitamin E on pigmentation and skin cancer induced by ultraviolet irradiation in Skh:2 hairless mice. *J Am Acad Dermatol* 2003; 49:458-472.
  86. Barnes S, Peterson TG, Coward L. Rationale for the use of genistein-containing soy matrices in chemoprevention trials for breast and prostate cancer. *J Cell Biochem Suppl* 1995; 22:181-187.
  87. Tham DM. Potential health benefits of dietary phytoestrogens: a review of the clinical, epidemiological and mechanistic evidence. *J Clin Endocrinol Metab* 1998; 83:2223-2235.
  88. Messina M, Barnes S. The role of soy products in reducing risk of cancer. *J Natl Cancer Inst* 1991; 83:541-546.
  89. Messina M, Persky V, Setchell K, et al. Soy intake and cancer risk: a review of the in vitro and in vivo data. *Nutr Cancer* 1994; 21:113-131.
  90. Barnes S. Effect of genistein on in vitro and in vivo models of cancer. *J Nutr* 1995; 125(suppl):S777-S783.
  91. Limtrakul P, Sutrajit M, Semura R, et al. Suppressive effect of soybean milk protein on experimentally induced skin tumors in mice. *Life Sci* 1993; 53:1591-1596.
  92. Kiguchi K, Constantinou AI, Huberman E. Genestein induced cell differentiation and protein-linked DNA strand breakage in human melanoma cells. *Cancer Commun* 1990; 2:271-278.
  93. Menon LG, Kuttan R, Nair MG, et al. Effect of isoflavones genistein and daidzein in the inhibition of lung metastasis in mice induced by B16F-10 melanoma cells. *Nutr Cancer* 1998; 30:74-77.
  94. Li D, Yee JA, McGuire MH, et al. Soybean isoflavones reduce experimental metastasis in mice. *J Nutr* 1999; 29:1075-1078.
  95. Akiyama T, Ishida J, Nakagawa S, et al. Genistein, a specific inhibitor of tyrosine-specific protein kinases. *J Biol Chem* 1987; 262:5592-5595.
  96. Hunter T, Cooper JA. Protein-tyrosine kinase. *Annu Rev Biochem* 1985; 54:897-930.
  97. Wei H, Spencer J, Gelfand J, et al. The isoflavone genistein: a new agent in dermatology? *Cosmet Dermatol* 2001; 14:13-19.
  98. Chan WH, Yu JS. Inhibition of UV irradiation-induced oxidative stress and apoptotic biochemical changes in human epidermal carcinoma A431 cells by genistein. *J Cell Biochem* 2000; 78:73-84.
  99. Fukunaga M, Oka M, Ichihashi M, et al. UV-induced tyrosine phosphorylation of PKC delta and promotion of apoptosis in the HaCaT cell line. *Biochem Biophys Res Commun* 2001; 289: 573-579.
  100. Hwang J, Sevanian A, Hodis HN, et al. Synergistic inhibition of LDL oxidation by phytoestrogens and ascorbic acid. *Free Radic Biol Med* 2000; 29:79-89.
  101. Wiseman H, O'Reilly JD, Adlercreutz H, et al. Isoflavone phytoestrogens consumed in soy decrease F-2-isoprostane concentrations and increase resistance of low-density lipoprotein to oxidation in humans. *Am J Clin Nutr* 2000; 72:395-400.
  102. Wei H, Cal O, Rahn RO. Inhibition of UV light- and Fenton reaction-induced oxidative DNA damage by the soybean isoflavone genistein. *Carcinogenesis* 1996; 17:73-77.
  103. Liu ZS, Lu YH, Rosenstein B, et al. Benzo-[A]pyrene enhances the formation of 8-hydroxy-2[prime]-deoxyguanosine by ultraviolet A radiation in calf thymus DNA and human epidermoid carcinoma cells. *Biochemistry* 1998; 37:10307-10312.
  104. Giles D, Wei HC. Effect of structurally related flavones/isoflavones on hydrogen peroxide production and oxidative DNA damage in phorbol ester-stimulated HI-60 cells. *Nutr Cancer* 1997; 29:77-82.
  105. Liu ZS, Lu YH, Lebowitz M, et al. PUVA (<sup>TM</sup>-methoxy-psoralen plus ultraviolet A) induces the formation of 8-hydroxy-22-deoxyguanosine and DNA fragmentation in calf thymus DNA and human epidermoid carcinoma cells. *Free Radic Biol Med* 1999; 27:127-133.
  106. Shyong EQ, Lu YH, Lazinsky A, et al. Effects of the isoflavone (genistein) on psoralen plus ultraviolet A radiation (PUVA)-induced photodamage. *Carcinogenesis* 2002; 23:317-321.
  107. Lin J-Y, Tournas JA, Burch JA, et al. Topical isoflavones provide effective photoprotection to skin. *Photoderm Photoimmun Photomed* 2008; 24:61-66.
  108. Wei H, Bowen R, Zhang X, et al. Isoflavone genistein inhibits the initiation and promotion of two-stage skin carcinogenesis in mice. *Carcinogenesis* 1998; 19:1509-1514.
  109. Chiu T-M, Huang C-C, Lin T-J, et al. In vitro and in vivo anti-photoaging effects of an isoflavone extract from soybean cake. *J Ethnopharmacol* 2009; 126:108-113.
  110. Moore JO, Wang Y, Stebbins WG, et al. Photoprotective effect of isoflavone genistein on ultraviolet B induced pyrimidine dimer formation and PCNA expression in human reconstituted skin and its implications in dermatology and prevention of cutaneous carcinogenesis. *Carcinogenesis* 2006; 27:1627-1635.
  111. Wei H, Barnes S, Wang Y. Inhibitory effect of genistein on a tumor promoter-induced *c-fos* and *c-jun* expression in mouse skin. *Oncol Rep* 1996; 3:125-128.
  112. Kang S, Chung J-H, Lee JH, et al. Topical N-acetyl cysteine and genistein prevent ultraviolet-light-induced signaling that leads to photoaging in human skin in vivo. *J Invest Dermatol* 2003; 120:835-841.
  113. Brandenberger AW, Tee MK, Lee JY, et al. Tissue distribution of estrogen receptors alpha (ER-alpha) and beta(ER-beta) mRNA in the midgestational human fetus. *J Clin Endocrinol Metab* 1997; 82:3509-3512.
  114. Kuiper GG, Carlsson B, Grandien K, et al. Comparison of the ligand binding specificity and transcript tissue distribution of estrogen receptors alpha and beta. *Endocrine* 1997; 138:863-870.
  115. Barkhem T, Carlsson B, Nilsson S, et al. Differential response of estrogen receptor alpha and estrogen receptor beta to partial estrogen agonists/antagonists. *Mol Pharmacol* 1998; 54:105-112.
  116. Castelo-Branco C, Duran M, Gonzalez-Merlo J. Skin collagen changes related to age and hormone replacement therapy. *Maturitas* 1992; 15:113-119.

117. Maheux R, Naud F, Rioux M, et al. A randomized, double-blind, placebo-controlled study on the effect of conjugated estrogens on skin thickness. *Am J Obstet Gynecol* 1994; 170:642-649.
118. Brincat M, Versi E, O'Dowd T, et al. Skin collagen changes in post-menopausal women receiving oestradiol gel. *Maturitas* 1987; 9:1-5.
119. Varila E, Rantala I, Oikarinen A, et al. The effect of topical oestradiol on skin collagen of post-menopausal women. *Br J Obstet Gynaecol* 1995; 102:985-989.
120. Affinito P, Palomba S, Sorrentino C, et al. Effects of postmenopausal hypoestrogenism on skin collagen. *Maturitas* 1999; 33: 239-247.
121. Greenwel P, Hu W, Kohanski RA, et al. Tyrosine dephosphorylation of nuclear proteins mimics transforming growth factor beta-1 stimulation of alpha-2 (1) collagen gene expression. *Mol Cell Biol* 1995; 15:6813-6819.
122. Sienkiewicz P, Surazyriski A, Palka J, et al. Nutritional concentration of genistein protects human dermal fibroblasts from oxidative stress-induced collagen biosynthesis inhibition through IGF-I receptor-mediated signaling. *Acta Pol Pharm* 2008; 65: 203-211.
123. Sudel KM, Veneke K, Mielke H, et al. Novel aspects of intrinsic and extrinsic aging of human skin: beneficial effects of soy extract. *Photochem Photobiol* 2005; B1:581-587.
124. Moraes AB, Haidar MA, Soares JM Jr., et al. The effects of topical isoflavones on postmenopausal skin: double-blind and randomized clinical trial of efficacy. *Eur J Obstet Gynecol Reprod Biol* 2009; 146:188-192.



## Hair care

John Gray and Jeni Thomas

### INTRODUCTION

Modern humans possess in toto as many hair follicles as our primate cousins. However we do not possess their all encompassing pelage. We have been selected for shorter and finer body hair and abundant hair only in locations associated with display and scenting. Human scalp hair is capable of growing to greater lengths than that of any other mammal for the purpose of sexual display and signaling and may have some variable but ultimately, vestigial role in thermoregulation.

The human head bears between 100,000 to 150,000 hair follicles. In an individual adult with 30 months' continuous, unstyled growth, some 30 to 45 km of hair is being carried (Fig. 28.1). This, in itself has consequences for overall appearance and grooming ease: the volume and phenotype have similar impact on the design of modern hair care products.

Caring for hair is an (almost) ubiquitous human habit (Figs. 28.2 and 28.3).

It is entirely consistent with mammalian grooming, enhancing appearance to consciously or subconsciously impart status, apparent health, wealth and physical attractiveness. The appearance of our hair is significantly affected by many factors including, obviously, climate and surprisingly, mood: The impact these have on the frequency of washing, conditioning, grooming and styling, is now established.

The physician of the 21st century ignores the importance of his or her patients hair, hair care practices and the products used designed to maximize physical attractiveness—at his or her peril. Patients with diffuse hair loss, the recovering alopecia areata, and postchemotherapy patients all rightly deserve cosmetic advice as part of holistic management.

### STRUCTURE OF HAIR: IMPACT ON HAIR CARE AND GROOMING

#### Morphology of Human Hair

The varied morphology of humans and their hair may be explained by both genetics and the adaptive consequences that occurred after the first diaspora of *Homo sapiens*. Genetic evidence suggests that *H. sapiens* originated only 200,000 to 250,000 years ago somewhere in the East-African savanna. Despite their apparent phenotypic variation, today's world population is potentially derived from as few as 1000 to 10,000 individuals, some 90,000 years ago, who eventually went on to populate the earth.

Human hair morphology varies from the literally flat to the perfectly round (Fig. 28.4). Typically, these have been allocated to perceived "racial" groups. However, single human scalps often bear a multiplicity of hair phenotypes.

#### Caucasoid, Negroid, and Mongoloid Hair Types

The literature perpetuates the taxonomy of hair as caucasoid, negroid, and mongoloid. These terms not only have a pejora-

tive ring but from a practical standpoint are scientifically inaccurate and no longer employed by publishers. Further, they are geopolitically incorrect. Other alternatives, such as Equatorial-African, Indo-European (IE) and Oriental, might better allocate the dominant phenotypes while recognizing the impact of past passive and forced migrations and the increasing homogeneity of the scalp hair of *H. sapiens* through gene sharing.

The cross-section of the hair shaft reveals three major components: the cuticle, the cortex, and the medulla (Fig. 28.5). The main constituents of hair are sulphur-rich proteins, lipids, water, melanin, and trace elements. The cortex, the main bulk of a fully keratinized hair shaft, contributes almost all the mechanical properties of the hair, including strength and elasticity. The cuticle consists of six to eight layers of flattened overlapping cells with their free edges directed upward to the tip of the hair shaft. Three distinct regions of the cuticle are recognized. Innermost is the endocuticle, derived from the developing cell cytoplasm contents. The exocuticle lies closer to the external surface and comprises three parts: the b-layer, the a-layer, and the epicuticle. The b-layer and the a-layer are largely proteinaceous. The epicuticle is a hydrophobic lipid layer of 18-methyl eicosanoic acid (18-MEA) on the surface of the fiber, or the f-layer. The epicuticle is not visible on routine microscopy.

The normal cuticle has a smooth appearance, allowing light reflection and limiting friction between the hair shafts. It is responsible for the luster and texture of the hair. The cuticle may be damaged by frictional forces (brushing, combing, or blow-drying) as chemical removal of the f-layer, particularly by oxidation, eliminates the first hydrophobic defense and leaves the hair more porous and vulnerable (Fig. 28.6).

If the cuticle is damaged there is little change in the tensile properties of hair, however, its protective function is diminished.(see section "Weathering and the Record of the Hair").

The morphology of hair and its condition at any one time determine the outcome of any interaction with a hair care product. The desire for an "end benefit" drives the product designer to diversify from the standardized products of the past.

### COSMETIC HAIR PROBLEMS

#### Weathering and the Record of the Hair

Weathering is the process of degradation of the elements of the hair shaft. This occurs with natural "wear and tear" but is much accelerated by physical and chemical process inflicted by the owner. The hair shaft records repeated cosmetic practices—the so-called record of the hair.

Although all hair exhibits some degree of weathering, longer hair, subjected to repeated insults, inevitably shows



**Figure 28.1** Long hair in an adult female.



**Figure 28.2** (A, B) Hair care processes.

more severe Changes; features of weathering include damaged cuticles, longitudinal fissures known as spilt ends, and transverse fissures resembling the nodes seen in trichorrhexis nodosa (Fig. 28.5).



**Figure 28.3** Variations in human hair morphology.



**Figure 28.4** Cross-section of the human hair.

Hair grows at circa  $\sim 0.4$  mm/day for between two and seven years, sometimes much longer.

Newly emerging hair has properties that are different from those of the hair tips. The more distal part of the hair shaft, particularly the tip, has typically undergone several hundred washes, the application of hot styling implements, and other cosmetic procedures such as bleaching, permanent coloring, and perming in addition to normal exposure to the environment. It may show the effects of weathering. The root may be less porous and have different chemical properties.

Hair care and hair care products are designed to cleanse and render the hair in a fit state for ease of grooming. The range of human hair—long and straight to short and intensely curled challenges the product formulator. The degree of damage inflicted on hair raises that challenge to greater heights.

### Surface Charge Changes with Weathering

- Hair coloring and bleaching changes the surface charge of hair which impacts the hair bulk properties. This change in surface charge is mainly driven by the removal of the f-layer during the oxidative treatment process.
- The f-layer is a monolayer of covalently bound branched fatty acid (18-MEA). This fatty lipid layer binds to the surface of the cuticle and acts as the hair's natural conditioning system. These lipids are bound to the surface by thioester linkages.



Figure 28.5 (A, B) Hair displaying signs of weathering.

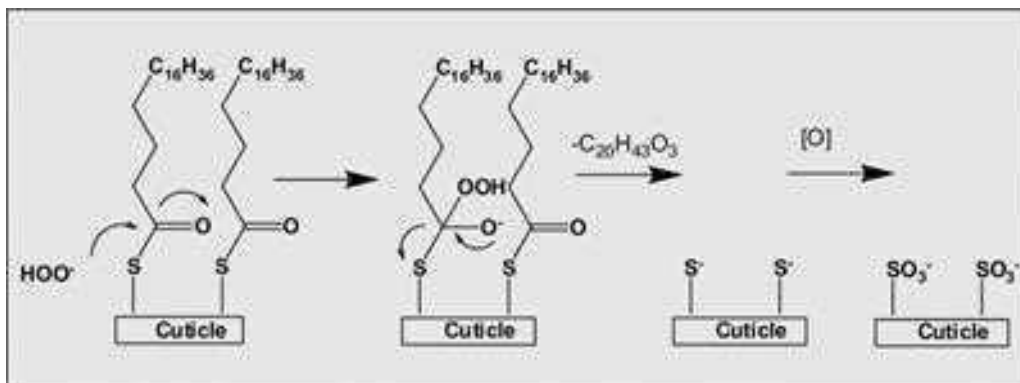


Figure 28.6 Mechanism of f-layer removal from hair.

- Coloring or bleaching with alkaline peroxide attacks the thioester groups that bind 18-MEA to the ultra high sulfur protein backbone at the surface of the hair and in the upper  $\beta$ -layer of the cell membrane complex (CMC) (1,2). This partially removes the hydrophobic surface barrier and weakens the cuticle-cuticle CMC against deformations in the dry state. The mechanism for the 18-MEA removal is thought to be perhydrolysis of the thio ester.
- *Increase in friction:* Bleaching hair increases hair fiber friction, and friction increases with increasing bleach damage (3). This has been observed at both high and low load. There is a larger frictional decrease from treatment of alkaline peroxide treated hair with cationic crème ingredients than with treatment of virgin hair with these same

ingredients. These results suggest a stronger interaction of bleached hair with cationic crème rinse ingredients that has been described (4) and are consistent with the higher concentration of ionized cysteic acid groups in the fibers (5).

- *Hair texture:* Alkaline peroxide treatment increases friction, making hair feel coarser (6). It produces a more irregular or varied scale pattern, which produces the perception of a more coarse texture versus chemically unaltered human hair (7). When female panelists were blindfolded and asked to rate hair for coarseness, the hairs with the greater degree of bleach damage were rated most coarse (8).

Hair freshly treated with an oxidation dye has a better wet feel immediately after treatment, but that feel gradually fades after several shampoo and conditioner

applications. With a condensation type reaction, as in oxidative dyeing, large molecules can form with three or more condensation units and larger species will tend to accumulate at or near the fiber surface. They resist rinsing off because the total binding force of van der Waals forces and polar attractions increase with molecular size. All molecules that bond on/in the surface layers can influence the surface properties of the hair such as friction, combing, and the more complex property of hair feel. These surface bound molecules will gradually be removed by shampooing.

- *Combing forces:* Permanent waving and bleaching hair with either alkaline peroxide or peroxide-persulfate make hair more difficult to comb (12,13). Permanent waving increases both hair fiber curvature and interfiber friction (9). Bleaching mainly increases interfiber friction (9). Crème rinses (10) and some conditioner sets (11) make hair easier to comb by decreasing interfiber friction. Chargeability (10) will also decrease with conditioners, thus improving fly-away hair and dry combing.
- *Style retention:* A water set in hair can be removed by either going to a higher relative humidity or a lower relative humidity (6). Changes in relative humidity or water content in hair fibers caused by either an increase or a decrease in relative humidity can cause curl loss or straightening of hair fibers wherein movement of water into or out of the hair causes changes in hydrogen bonding that allows for molecular rearrangements to occur causing hair to revert to its natural curvature or natural curl pattern and loss of a water set.

Oxidative dyes with alkaline peroxide increase interfiber friction (9,12), thus they help hair stay in place to improve style retention.

- *Hair body:* Changes in hair fiber curvature produce large changes in hair body hair body may be defined as thickness or apparent volume of a hair assembly, involving sight and touch for assessment (3). The quality of liveliness or springiness is also associated with hair body. Hair curvature, friction, stiffness and fiber diameter will increase hair body and ingredients applied to hair that provide an increase in cohesion of hair fibers or weight on the hair will decrease hair body. Robbins has shown that for cohesive effects a change in fiber curvature has a greater impact on hair body than the other fiber properties (stiffness, friction, and fiber diameter) (13).
- Permanent waves, hair bleaches, and oxidation dyes increase hair body. Permanent waving does this by increasing fiber curvature and friction (9,12). Bleaching and oxidation dyeing increase interfiber friction substantially (9,12), increasing body.

## OTHER COSMETIC PROBLEMS

- *Knots:* Knots can form in hair, especially curly hair. Knots in hair eventually lead to hair damage and breakage.
- *Flyaway:* Curly hair provides less flyaway than straight hair under the same conditions. Robbins (13) has demonstrated that straight hair has a greater tendency to flyaway than curly hair, even when a similar level of static charge has been built up on the fibers. Fiber entanglements of curly hair inhibit the separation of hairs as occurs in static flyaway, and this effect to inhibit flyaway becomes greater as the hair fiber curvature increases.

- *Shine:* Curl in hair decreases hair luster by producing poor alignment of hairs. Hair curl or coiling of hair fibers produces misalignment of hairs which produces dull hair. Single hairs of African-Americans are among the shiniest of hairs. It is only because of the high coiling and poor alignment that an array of hair from an African American does not appear shiny. Therefore, curly to highly coiled hair of blacks often thought of as not being shiny would be even less shiny if it contained less pigment.
- *Oil transport:* Curly-coarse hair is least affected by cohesive forces of oily soils on hair. Curly-coarse hair will tend to inhibit transport and also to minimize the influence of tress compacting by oily ingredients. Among all hair properties, increasing fiber curvature provides the greatest influence against the cohesive forces of hair lipid and the resultant compacting of tresses (limpness) by oily/greasy ingredients (5), thus curly hair will appear less oily and less limp than straighter hair with the same amount of oily/greasy ingredients on it. This is why very large amounts of oils/greasy ingredients are applied to hair in pomades, amounts too large to be deposited from a shampoo or a standard rinse-off hair conditioner used by Caucasians and Asians.

## SURFACE CHARGE CHANGES AFTER COLORING AND BLEACHING

Hair coloring and bleaching changes the surface charge of hair which impacts the hair bulk properties. This change in surface charge is mainly driven by the removal of the f-layer during the oxidative treatment process.

The f-layer is a monolayer of covalently bound branched fatty acid (18-MEA). This fatty lipid layer binds to the surface of the cuticle and acts as the hair's natural conditioning system. These lipids are bound to the surface by thioester linkages.

Coloring or bleaching with alkaline peroxide attacks the thioester groups that bind 18-MEA to the ultra high sulfur protein backbone at the surface of the hair and in the upper  $\beta$ -layer of the CMC (14,15). This partially removes the hydrophobic surface barrier and weakens the cuticle-cuticle CMC against deformations in the dry state (16). The mechanism for the 18-MEA removal is thought to be perhydrolysis of the thioester.

## HAIR CARE REGIMENS

Hair care products initially focused on the sole purpose of removing dirt and oil from hair. Hair care products have since, evolved to not only gently cleanse hair, but to enhance its esthetics by sustaining its core elements (i.e., cortex, cuticle) and facilitating desired styles. Conditioning actives can now be delivered to hair from a shampoo, from a separate rinse-off product, or from a leave-on treatment used outside of the washing environment. Conditioners help control the flux of moisture in and out of the hair fiber, provide lubrication to minimize friction-related damage, reduce static charge, and smooth rough surfaces. They contribute to, feel, appearance, resilience and manageability.

In recent decades, hair care products have been transformed from the functional but often unpleasant, to versatile, creative and quality-of-life enhancing. A hair care regimen includes a basic cleansing and conditioning product often with a number of variants to meet consumer needs. These

products are generally used separately, and conditioning usage is still much less than shampoos despite the increasing use of chemistry on the hair.

Combination, or two-in-one, products developed by Procter and Gamble (P&G) in the late 1980s delivered for the first time cleansing and conditioning benefits from a single bottle.

Regimen ranges were classically designed for three hair types: normal, dry, or damaged hair. Subsequent generations of products were created to deliver a desired end benefit, such as “smooth and sleek,” “perfect curls,” and “color radiant.” A range of styling products to create long-lasting styles have also emerged to complement the cleansing and conditioning products.

These can enhance or alter most common esthetic styling problems. Foremost among these is the control of “volume,” either too little or too much. Managing frizzy hair is important and products for so-called “ethnic” hair are emerging.

Current hair care regimens can vary from zero to six products a day. While previous generations may have had nothing and relied solely on grooming, in an increasingly competitive society, the prolonged wearing of unwashed, matted, and neglected hair is considered eccentric at the very least.

Daily shampooing alone is harmless to the hair shaft, and in itself can improve the ability to groom and style. Hair care products, in comparison with skin care are inexpensive and ubiquitous. Curiously in some developed societies, bar soaps for washing the scalp, particularly among men, are still sadly, common. These harsh anionic surfactant systems are not just poor cleansers, but also lead to extensive calcium salt buildup in the hair and reduced grooming capability.

Recent research (P&G data on file) indicates that, despite improvements over the last two decades, 70% of women still experience dissatisfaction in achieving the end result they desire. This failure of expectation may be due to product choice based either on the hair type or on the prospective “look,” without options to link the two for a more tailored solution. For

example, “moisturization” is a common need, but current technologies offer a single formula designed to deliver a moisturization benefit regardless of the hair type. The technology that would be most effective for delivering a moisturization benefit to thick hair would be far too heavy and unappealing for fine hair.

In the future a more sophisticated approach encompassing targeted products based on fundamental hair characteristics will be available (see recent developments).

## HAIR CARE PRODUCTS

### Shampoos

Shampoos are the bedrock of hair care. Modern high-quality shampoos have evolved from agents that once merely and harshly removed grease (sebum), perspiration, environmental dirt, and dead corneocytes. In the twenty-first century they contain agents that enhance the natural beauty of hair and mitigate the damage which the owners inflict.

Shampoos consist of three major components.

- Primary surfactants (surface-active molecules) for detergency and foaming power
- Secondary surfactants to improve and condition the hair
- Additives that complete the formulation and add special esthetic effects

The surfactants or detergents act by removing the dirt from the hair with a lipophilic component and transferring it to the rinse water with hydrophilic component (Tables 28.1 and 28.2).

#### *Moisturizing Shampoos*

Moisturizing shampoos are designed for dry hair and can include essential oils such as petrolatum as well as the surfactant systems described above. They are orientated toward those with hair of African origin or hair that is excessively dry. They leave the hair feeling moisturized and easy to comb. These products are also designed to help weathered and colored hair.

**Table 28.1** Classical Shampoo Formulation: with Ingredient Function

Ingredients	Material function	Details
Aqua	Purified water	Bulk matrix
Ammonium laureth sulfate	Surfactant	Cleaning
Ammonium lauryl sulfate	Surfactant	Cleaning
Sodium chloride	Viscosity control	Controls thickness of final product
Glycol distearate	Pearlescent	Visual esthetics
Dimethicone	Conditioning agent	Improves hair feel
Ammonium xylenesulfonate	Viscosity control	Controls thickness of final product
Sodium citrate	Ph balancer	Controls pH of final shampoo
Citric acid	Ph balancer	Controls pH of final shampoo
Cetyl alcohol	Conditioning agent	Lubricates hair
Panthenol	Provitamin	Humectant
Panthenyl ethyl ether	Provitamin	Humectant
Cocamide MEA	Foam booster	Improves lather performance
Polyquaternium 10	Conditioning agent	Improves hair feel and provide body
Parfum	Perfume	
Laureth 4	Surfactant	Solubilizes perfume
Trimethylpropane tricaprilate/tricaprate	Conditioning agent, rinse modifier	Improves hair feel, rinses faster, clean rinse feel
Hydrogenated polydecene	Conditioning agent	Improves hair feel
Tetrasodium EDTA	Preservative enhancer	Metal ion absorber
Disodium EDTA	Preservative enhancer	Metal ion absorber
DMDM hydantoin	Preservative	
Sodium benzoate	Preservative	
Methylchloroisothiazolinone, methylisothiazolinone	Preservative	Kathon

**Table 28.2** Ingredients and Their Functions

Ingredients	Material function	Details
Aqua	Purified water	Bulk matrix
Cyclomethicone	Conditioning agent	Lubricates and improves hair feel
Stearamidopropyl dimethylamine	Conditioning agent and emulsifier	Improves hair feel
Cetyl alcohol	Conditioning agent	Lubricates hair
Quaternium-18	Conditioning agent and emulsifier	Reduces static
Stearyl alcohol	Conditioning agent	Improves hair feel
PEG-2M	Conditioning agent	Improves hair feel
Cetearyl alcohol	Conditioning agent	
Polysorbate 60	Solubilizer and emulsifier	
Benzyl alcohol	Preservative	
Panthenyl ethyl ether	Provitamin	Humectant
Panthenol	Provitamin	Humectant
Dimethicone	Conditioning agent	Improves hair feel
Hydroxyethylcellulose	Thickening agent	
Glyceryl stearate	Emulsifier	
Oleyl alcohol	Conditioning agent	Improves hair feel
DMDM hydantoin	Preservative	
EDTA	Preservative enhancer	Metallon absorber

Originally there were no shampoos specifically designed for African hair. However, African hair benefits from shampoos that contain mild cleansing agents (detergents) help detangle the hair and are pH balanced in the range of 4.5 to 5.5. Shampoos formulated for other hair types may not help to detangle hair sufficiently, contributing to combing damage.

### Conditioning Agents

Conditioning materials are formulated as emulsions and are traditionally applied after shampooing to increase hair “quality” before grooming. They reduce negative charge, prevent flyaway, increase miscibility and hence reduce tangling. Other ingredients (see below) are humectants.

In the past the only available “conditioners” were equivalent to greasy pomades offering protection against the harsher effects of relaxers, permanents, straighteners and colorants were common. Modern intensive conditioners are much pleasanter and if used regularly can obviate the effects of these processes.

Modern, high-quality conditioners increase the manageability, shine, and moisture content of each hair shaft. Modern products are designed to provide one or more of the following functions:

- Increase the ease of wet and dry combing
- Smooth, seal and realign damaged areas of the hair shaft
- Minimize porosity
- Impart sheen and a silken feel to hair
- Provide some protection against thermal and mechanical damage
- Moisturize
- Add volume and body
- Eliminate static electricity

Regular condition contributes significantly to the preservation of the external architecture and internal chemical chemistry of each hair shaft. Frequent chemical processing makes conditioning even more important.

Dry, woolly hair generally requires heavier deposits of conditioners than other hair types. The use of leave-in or “intensive” conditioners is growing. The use of moisture-retaining ingredients (humectants) such as panthenol, can be

augmented by cationic ingredients (e.g., polyquaternium derivatives), which leave hair manageable. Treatment with polymeric conditioning agents that bond to the hair at points of damage also aid in improving resistance to breakage. Increasingly, light conditioning materials are added to shampoos (other than clarifying) to improve end results.

### KEY CONDITIONING MATERIALS

#### Silicones

Embue extreme softness to hair, provide dry combing capability and increase shine.

#### Cationic Polymers

Positively charged molecules which are attracted preferentially to areas of damage. Makes hair easier to comb, softer, smoother and less static.

#### Fatty Alcohols

Give hair a smooth feel when dry and improves wet combing. They are creamy in texture and give product thick, creamy appearance.

Also help to retain moisture.

#### Quats/Amines

Enable combing and control static.

#### Oil Emollients

Moisturize hair to improve softness.

Conditioning hair is critical to its sustained integrity as it inevitably weathers over time. Chemical and physical processing remove the outer lipid coating of lipids (the f-layer) and result in amino acid degradation in the cortex of up to 50%.

### STYLING ISSUES IN HAIR CARE

For most ordinary people, a good cut utilizing the intrinsic nature of the hair and its patterns is the first essential for good style. Thereafter, maintaining or creating a daily style is a

**Table 28.3** Typical Volume-Styling Ingredients

Ingredient type	Examples	Function
Styling polymers	Water based: polyquaternium 4, acrylates copolymer, PVP/VA copolymer Alcohol based: acrylates/dimethicone copolymer, octylacrylamide/acrylates/butylaminoethyl methacrylate copolymer Waxy: petrolatum, beeswax, oleth-5	“Active ingredients” that form bonds between hair strands
Plasticizers and neutralizers	Aminomethyl propanol, triethanolamine, potassium hydroxide, isododecane, aminomethyl propanol	Ingredients that modify polymer properties to make them more flexible and easier to wash out of hair
Solvents	Water, SD alcohol	Liquids that serve as carriers for other ingredients and evaporate after product is applied to hair (usually water or ethanol)
Thickeners	Hydroxyethylcellulose, acrylates/behent-25 methacrylate copolymer, carbomer	Ingredients that build viscosity of solution to help application
Conditioning agents	Propylene glycol, polyquaternium 11, dimethicone copolyol	Help to improve softness and shine attributes
Preservatives	DMDM hydantoin, disodium EDTA, tetrasodium EDTA, phenoxyethanol, propyl paraben	Prevent microbial contamination of product
Propellants	Isobutane, propane, dimethyl ether	Pressurized gases to provide necessary force to push product out of container.
Surfactants	Peg 40 hydrogenated castor oil, C9-11 pareth 8, isosteareth 20	Used to help dissolve oils in a water-based system. Also used in mousses to work together with propellant to create foam. Can improve spreadability of product.
Fragrances		Impart a appealing scent or coverup a raw material odor.

combination of cleansing, conditioning, physical effects (natural or forced drying), and styling products to give long-lasting control.

Control of “volume” is the most common reason for “styling”—either too much or too little. The hairstyle can be used to help accent facial features and camouflage the worst. However for many this is not an easy option and is influenced by hair density and diameter and hair shaft characteristics. Curly hair is more difficult to groom and tends to frizz. Tightly curled hair lends itself to sculpting and can only be styled if relaxed. Strong straight hair may defy any attempt at styling (Table 28.3).

Long-lasting volume can be defined as: “hair that is lifted and held away from the scalp which defies gravity and humidity over time.” For the physician key clues to understanding how volume works is described below.

### VOLUME PROBLEMS

Modern hair care products applied correctly and regularly can contribute significantly to the amelioration of these problems. To the office physician this may be an important part of management for a variety of hair loss conditions or those with hair shaft abnormalities.

### Factors Influencing Hair Volume

The key physiological factors affecting volume are as follows:

- Diameter
- Density
- Stiffness
- Friction
- Cohesion

There are three main ways to build long-lasting hairstyle.

- Reshaping the hair strand through wet setting
- Creating frictional interactions to help hairs hold each other up
- Bonding the hair strands at critical points to hold the shape over time

### WET SETTING

The process most people use to reshape the hair strand is *wet setting* to increase curvature or set a shape in the hair. The basic process is to wet the hair by either shampooing or applying a wet styler. Shampooing works best because the surfactants help the water penetrate the hair shaft really well. Once the hair is wet it is redried into shape either by air drying on rollers or heat drying with a blowdryer on a round brush.

Water in the air as humidity can also penetrate the shaft and loosen hydrogen bonds. The best way to prevent humidity attack is to use hair spray on finished style. Hair spray polymers are the most humidity resistant polymers and not soluble in water alone.

Certain phenotypes have generic problems—Nordic hair is regularly fine and tends to lankness and lack of body. Curly dry hair has too much and suffers from grooming problems.

### Blow-Drying

With the introduction of precision cutting techniques in the 1970s, blow-drying became universally popular at home. Processed hair then exposed to high levels of heat and mechanical manipulation may result in excessive damage gives conditioning great importance.

Even natural hair can be blow-dried to loosen the curl. Blow-drying products are designed to help protect the hair

from heat and dehydration, and to reduce the combing force exerted in the blow-drying process. Specifically, lotions and silicone gels formulation have been developed.

### Pressing

Physically straightens excessively curly hair using heat, oils and metal implements. A *hot comb* is still the most popular implement in the United States for the temporary straightening of hair (more dramatic effect than blow-drying).

The temperatures of hair dryers sometimes exceed 200°C and may cause tremendous damage. Petrolatum is a commonly used ingredient to offset damage. The treated hair subsequently remains straight until moisture causes reversion back to its curly appearance. The hair may later be set on rollers.

In those with African hair this process can be damaging to both hair and scalp and may lead to hot-comb alopecia (baldness).

### Setting

Like clothing fashions, various hair setting techniques have come, gone and returned again with great vigor to the ethnic market. Some styles are achieved with rollers, and others accomplished by various “molding techniques” such as waving and wrapping.

Reducing hair or the use of hot irons does not produce permanent straightening of hair. Reductive methods or hot irons when used separately provide only temporary hair straightening in which the hair will revert to its original curvature, or close to it, either by washing or on exposure to high humidity. However, these scientists demonstrated that by combining reducing solutions such as TGA or TGA/dithiodiglycolic acid (DTDG) followed by a hot press application immediately after the reduction reaction that permanent straightening can be achieved.

Hot curling or straightening irons can produce hair damage curling hair with curling irons can cause hair damage.

### TEMPORARILY INCREASING HAIR FRICTION

There are three ways of temporarily increasing friction which also helps increase volume and fullness.

**Cleaning:** Hair’s natural oils or sebum can build up over time, making hair more slippery and reduce friction and make hair limp. Cleaning these oils off with a volume building shampoo will restore hair’s natural for long-lasting volume.

**Teasing or backcombing:** Teasing or combing hair backward from tip to root will roughen the cuticle, drastically increasing friction. This temporarily creates volume but is potentially very damaging over time.

Teasing causes the cuticle layers to roll and peel up.

**Foundation stylers like mousse and gel:** Styling gels and mousses temporarily increase friction during styling to help you achieve style.

Unfortunately, volume created via friction alone can collapse over time as hair is blown around by the wind, head shaking or other forms of disruption. Volume created by friction alone is unreliable.

Volumizing conditioners and styling products containing ingredients such as polyquatonium and stearamidapropyl dimethylamine prevent static charge buildup in fine hair.

These ingredients are charged and conductive and help dissipate the static buildup in hair.

### BONDING THE HAIR STRANDS AT CRITICAL POINTS TO HOLD THE SHAPE OVER TIME

Styling products help keep long-lasting volume by creating reinforcing bonds between hair shafts at critical locations to the style. These bonds come in two types.

- **Seam welds:** Seam welds are bonds created that hold two hair shafts together in in side by side alignment.
- **Spot welds:** Spot welds are found where hairs cross each other to create a support structure. The styling polymer glues the shafts together at this critical structural point.

All styling products create both kinds of welds. However, mousse, gel and waxes are preferred for creating seam welds. This is because they are applied in larger quantities and typically rubbed by hand before the finished style is created. Hair spray is preferred for creating spot welds because it is applied through the air in droplets to finished style and thus can act on critical hair cross over points.

Styng products for volume can generally be categorized into three categories by their key holding polymers.

Reshaping the hair strand stiffness of the hair mass can be enhanced by using styling products with holding polymers which can temporarily improve this feature by bonding together separate hairs – when the hairs work together they have more natural lift and stiffness.

Physical attributes of hair care can be achieved by shaping with a brush or rounded comb. Lifting the roots off the scalp and supplementing this with a foundation styler like mousse or gel can help to help set the curve. Gentle heat makes the styling polymers melt and flow to increase hair to hair contact and provide even better long-lasting hold.

Styling gels and mousses temporarily increase friction during styling to help achieve the desired style. As the film partially dries they go through a tacky or sticky phase. This helps hold hair into shape while finishing by drying the hair. Once the film is completely dry, it stops feeling sticky and the style is set.

### PRODUCT TYPES

#### Water-Based Stylers

Water-based styling polymers are delivered to the hair as a film that dries relatively slowly. As the film dries it becomes tacky and forms bonds between hair strands, making the desired style easier to achieve and maintain. After the hair is dry, the polymer forms a hard film that bonds the hair into place. Combing or disrupting the hair can break the bond, but even the broken pieces provide some friction, which provides some hold benefits by helping to prevent hair strands from sliding across each other.

*Gels* are water-based products that use water-based polymers with a variety of thickeners to achieve the desired product consistency and texture. Gels are typically applied by hand and can either be air dried for a shiny, wet look finished or blow-dried for a drier, softer look. Because of their thickness they are particularly good for creating seam welds that increase apparent hair stiffness and give a texturized look and great root lift.

*Spray gels* are typically very similar to thick gels minus the thickeners. Application using a nonaerosol pump enables



consumers to apply product very evenly through the hairstyle with no mess. Spray gels are great for creating all over fullness.

*Mousses* use a propellant (pressurized gas) and a surfactant in addition to water-soluble styling polymers to help create a smooth, creamy foam. When the consumer shakes the can, liquid propellant is mixed with the water-based liquid concentrate. Then, when the can is inverted and product is dispensed, the pressure of the vapor propellant pushes the mixture of liquid propellant and liquid concentrate out of the can. The liquid propellant then quickly evaporates, creating foam. The mousse foam makes it easy to apply the styling polymers to your hair because in the foaming state it can be spread very thinly. This makes mousse great for long hair that would be weighed down by large clumps of polymer. Another benefit of mousse is that in its foamy state it is not runny and thus will stay where you put it—making it another good alternative for adding root lift to a straight style.

### WAX-BASED STYLERS

Waxes are the ultimate styling products. They primarily hold hair through seam welds creating large locks of many hair bonded together. The result is hair that stands up from the scalp in large chunks creating a, texturized look. The holding power is created by the waxy materials internal stickiness or cohesiveness. The waxy materials do not “dry” because they are not water soluble. The positive benefits of not drying means that the bonds can be easily remolded by running your hands through the hair over time. However hair is still susceptible to humidity and disruption over time. These are the most remoldable, and can give significant root lift. But they are potentially heavy and greasy if over used. They are best used on very short hairstyles. They can be difficult to wash out of hair given that waxes are water repellent. Use of a clarifying or purifying shampoo is recommended with waxes.

Tips for dispensing stiff waxes—use the back of the knuckles to get the wax out the jar without getting wax under the fingernails.

### Pomades

Pomades are typically a water and oil emulsions which combine water-soluble polymers with waxy ingredients. These products combine the look of waxes with some of the hold of water-based styling polymers. The balance of waxy to water-based polymers impacts the amount of remoldability and humidity resistant hold. These are good for creating end flicks and flips and piecing out layers and bangs.

### Alcohol Based

Alcohol based styling polymers are delivered to the hair in a solution of polymer and alcohol that dries very quickly. The rate of drying is much faster than that for water-based styling products because alcohol evaporates much faster than water. As the alcohol evaporates the film dries, forming bonds between hair strands, welding the hairs together in the desired style. Fast drying rate makes alcohol based stylers perfect for locking in finished styles because it does not rewet the hair.

Alcohol based polymers are typically much more humidity resistant than water-based polymers. That is because alcohol based polymers require surfactant, like shampoo, to make them soluble in water. Thus the water available via high humidity does not soften or loosen hair spray bonds.

### Hair Spray

Hair spray is the most common alcohol based styler and is a solution of polymer in a mixture of alcohol and water that is sprayed on the hair in droplets. The droplets are formed when the liquid is forced through a pinhole in the nozzle of the can. In aerosol hair sprays, the force is supplied by propellant. In nonaerosols, the force is supplied via mechanical action of pumping the nozzle. Typically, nonaerosol's propellants provide more force than mechanical pumping resulting in smaller droplet sizes. Smaller droplets dry faster giving aerosol hair spray a “drier” feeling than nonaerosol hair spray.

Hair spray droplets range in size from 30 to 40  $\mu\text{m}$  for aerosols and 45 to 55  $\mu\text{m}$  for nonaerosols.

### HAIR WITH SPECIAL NEEDS

Of the three major phenotypic hair Caucasian (or IE) African and Oriental—all have attributes and difficulties with hair care.

*Subequatorial African hair* is unique in its appearance and esthetic qualities and differs from IE and Oriental hair in its lower attainable length, flattened fiber shape, reduced diameter, lower density, unique amino acid content, and lower tensile properties such as elasticity and percentage elongation at its breaking point. It is curiously fragile and tends to knot and easily develop longitudinal grooves which render it even more fragile.

In addition it tends to be drier than Oriental or IE hair and consequently often requires special moisture-rich cosmetic products or treatments to create or hold styles and maintain its “health.”

African hair presents special difficulties during grooming due to its curly structure, which renders it difficult to untangle and comb.

IE hair encounters more difficulty in wet combing than dry (hence the need for conditioners). This type of hair has a range of phenotype from fine and straight to medium diameter with wave or curl. Curly hair is an intermediate in hair care. It has natural volume but tends to frizz.

Oriental hair mostly, but not invariably is dark straight to gently wavy but with higher diameter may become spiky and difficult to manage.

### RELAXING AFRICAN-AMERICAN HAIR

Chemical restructuring agents are now predominantly used by women. And by far the commonest hair “style” in women of African-American descent is to wear the hair relaxed. An estimated 70% of U.S. women undertake this on a regular basis. This can only be achieved by chemical processing and straightens the hair allowing to be worn in “Caucasian” fashion or permitting less challenging curls to be formed by reprocessing. The damage to the already fragile hair may be significant.

### Relaxers

Chemical hair products that permanently straighten hair are called straighteners or relaxers. Relaxation of tight curly hair is normally achieved by application of 2% to 4% alkali based relaxers. Most relaxers are formulated in the form of heavy creams consisting of very high oil-in-water emulsions which are combed through the hair where they slowly break down the structural bonds. The aggressiveness of the caustic is controlled by the incorporation of suitable emollient oils (Table 28.4).

**Table 28.4** Comparison of Relaxer Types

Characteristics	Lye	No-lye
Relative strength	3	1
Alkaline active	NaOH or KOH	Guanidine hydroxide Lithium hydroxide
Chemical agent	OH <sup>-</sup>	OH <sup>-</sup>
pH	12.5–14	12.5–13.5
Penetration and spreading	Faster	Slower
Relaxer processing time	Shorter	Longer
Irritation potential	Higher because of lower safety margin	Lower because of a higher safety margin
Drying potential	Less drying to hair and scalp	More drying to hair and scalp

*Note:* No-lye products, although considered less harsh, can still burn the scalp, eyes, and ears.

### Relaxer Chemistry

Relaxers consist of three principal components: *an alkaline agent, an oil phase, and a water phase*. Relaxers need a strong alkaline component; this may be sodium, potassium or lithium hydroxide, or guanidine hydroxide formed by the reaction of guanidine carbonate and calcium hydroxide. The oil phase contains a high concentration of oils as well as a surfactant. Because these lipid materials add sheen to the hair, ease combing and lend some barrier protection to the scalp, the oil phase can be considered a conditioning and protecting vehicle.

Relaxers are the most popular method of straightening hair. The two most common types of relaxers are sodium hydroxide (lye) and guanidine hydroxide (no-lye). Also on the market are potassium and lithium hydroxide relaxers as well as ammonium bisulfite relaxers. However, sodium hydroxide and guanidine hydroxide have proven to be the most effective. Guanidine hydroxide relaxers are considered less irritating to the scalp than lye based relaxers; therefore, some consumers prefer them.

### RECENT PRODUCT DESIGN PARAMETERS

The key variables that define the properties of an individual hair fiber are as follows:

- Diameter/cross-sectional area

- Degree of curvature
- Surface properties

These single fiber variables impact the bulk hair properties and they influence how hair fibers interact with each other.

*Hair shaft diameter* can be connected to tensile properties, bending properties, torsional effects, hair volume, friction, curl retention, hair feel, combing ease, and rate of sebum transport.

*Degree of curvature* can be connected to combing ease, knotting, shine, body, oiliness, and style retention.

*Surface properties:* The surface properties of hair can be divided into two areas of discussion, and both types of surface property changes lead to differences in the bulk hair properties.

- Topography changes: changes to the surface roughness and cuticle alignment, etc.
- Surface charge changes: changes in hydrophobicity, surface charge, etc.

In addition to the single fiber properties, it should be noted that one's cut, hair length and density will also affect the bulk hair properties.

Recent advances in polymer and formulation science, is enabling the development of new hair care technology expected to curtail this dissatisfaction. This research has shed light on the unique needs of different hair types and the impact of hair's structure, on the single fiber and multifiber level, on



**Figure 28.7** Four distinct hair types (*in shaded boxes*) differentiated by their chemical and physical structures.

**Table 28.5** Key Variables in Design of Hair Care Products

Hair type	End benefit	Performance profile desired	Shampoo and conditioner formulation parameters
Fine	Volume	<ul style="list-style-type: none"> <li>• Good cleaning (<i>high removal of sebum</i>)</li> <li>• Low deposition of conditioners</li> <li>• Ability to style with volume</li> </ul>	<ul style="list-style-type: none"> <li>• In shampoo, highest concentration of effective surfactants, including HPM cellulose, a polymer that gives a cleaning boost</li> <li>• Lowest levels of conditioning</li> <li>• Adhesion deposition mechanism</li> </ul>
Fine	Moisturized	<ul style="list-style-type: none"> <li>• Good cleaning (<i>high removal of sebum</i>)</li> <li>• Medium deposition of light-weight conditioners to give soft, smooth feel to hair without a loss of volume</li> </ul>	<ul style="list-style-type: none"> <li>• In shampoo, high concentration of effective surfactants, yet slightly lower than for the version designed to deliver volume to fine hair</li> <li>• Poly(DADMAC) polymer designed to increase hydrophobicity of hair surface, give conditioned feel, and aid deposition of silicone from the conditioner</li> <li>• Adhesion/aided deposition mechanism</li> </ul>
Medium/thick	Moisturized	<ul style="list-style-type: none"> <li>• High deposition of conditioners to give soft, smooth feel to hair</li> </ul>	<ul style="list-style-type: none"> <li>• Different choice of surfactants than used in the Fine, Moisturized product</li> <li>• Poly(DADMAC) polymer designed to increase hydrophobicity of hair surface, give conditioned feel, and aid deposition of silicone from the conditioner (1.5× silicone levels in fine, moisturized conditioner)</li> <li>• Aided deposition mechanism</li> </ul>
Medium/thick	Smooth	<ul style="list-style-type: none"> <li>• Soft, smooth feel to hair</li> <li>• Close alignment of hair fibers</li> </ul>	<ul style="list-style-type: none"> <li>• Triquat-76 polymer system used instead of Poly(DADMAC) to aid deposition of conditioning ingredients without modifying hydrophobicity</li> <li>• Silicone levels in shampoo are 50% of the levels in the medium/thick, moisturized shampoo version</li> <li>• Hybrid deposition mechanism (filtration and adhesion)</li> </ul>

Abbreviation: Poly(DADMAC), poly(diallyldimethylammonium chloride).

product performance. These recent findings and formulation options open the door for a more customized approach to hair care, while still focusing on delivering the end benefit.

The design approach now incorporates both the starting and end points, as described above, with the starting point included in a more intuitive and technically meaningful way. Under this model, moisturization benefits specific to fine hair can be offered separate from moisturization benefits best suited to thick hair.

Product formulation now defines key target areas as in Figure 28.7.

New hair care technologies and formulas are being developed against the needs of each of these four groups on the basis of the understanding of the impact of hair's structure on product performance.

As the new formulas are specifically designed not just for the hair type but also for a specific end benefit, their ingredient and performance profiles vary to deliver the relevant benefit. Table 28.5 illustrates how the shampoo and conditioner formulas have been adapted for (i) the same hair type yet different end benefits and (ii) different hair types yet the same end benefit. The same principles apply to all types of hair care products (i.e., styling products and leave-on treatments).

## CONCLUSION

Understanding "hair care" is an important part of the physician's role. The judicious use of physical methods in conjunction with the whole panoply of modern cosmetic products from cleansing, conditioning and styling applied correctly and with the right advice can improve the quality of life for many patients.

## REFERENCES

- Berarddesca E, Leveque J-L, Maibach HI. *Ethnic Skin and Hair*. New York: Informa Healthcare USA, Inc., 2007.
- Ogle RR, Fox MJ. *Atlas of Human Hair; Microscopic Characteristics*. Boca Raton: CRC Press, 1999.
- Kaswell ER. *Textile Fibers & Fabrics*. New York: Reinhold, 1953: 52.
- Steggarda M, Siebert HC. Size and shape of head hair from six racial groups. *J Heredity* 1941; 32:315-318.
- Wolfram LJ. Human hair: a unique physicochemical composite. *J Am Acad Dermatol* 2003; 48:S106-S114.
- Syed AN, et al. African-American hair: its physical properties and differences relative to Caucasian hair. *Cosmet Toil* 1995; 110:39-48.
- Vernall DG. A study of the size and shape of cross-sections of hair from four races of men, *Am J Phys Anthropol* 1961; 19:345-350.
- Franbourg A, Hallegot P, Baltenneck F, et al. Current research on ethnic hair. *J Am Acad Dermatol* 2003; 48:S115-S119.
- Nagase S, Tsuchiya M, Matsui T, et al. Characterization of curved hair of Japanese women with reference to internal structures and amino acid composition. *J Cosmet Sci* 2008; 59:317-336.
- Robbins C. *Chemical and Physical Behavior of Human Hair*. 3rd ed. Berlin, Heidelberg, New York: Springer-Verlag, 1994:328-330.
- Loussouarn G, et al. *Int J Dermatol* 2007; 46(suppl 1):2-6.
- Bailey J, Schliebe S. The precision of the average curvature measurement in human head hairs. *Proceedings of the symposium on forensic hair comparisons, FBI, U.S. Government Printing Office, Washington, D.C., 1985*.
- Robbins C. *Chemical and Physical Behavior of Human Hair*. 4th ed. Berlin, Heidelberg, New York: Springer-Verlag, 2002.
- Robbins, et al. *J Cosmet Sci* 2004; 55:351-371.
- Reutsch and Kamath, *IFSCC Magazine* 2004; 7:299-307.
- Robbins C. *Chemical and Physical Behavior of Human Hair*. 4th ed. Berlin, Heidelberg, New York: Springer-Verlag, 2002:398-399.

**FURTHER READINGS**

- Campbell ME, et al. *Aust J Biol Sci* 1975; 28:389.
- Dawber R, Van Neste D. *Hair & Scalp Disorders*. London: Martin Dunitz, 1995:19.
- Kawasoe T, et al. Tribiology in the hair surface and tactile perception. *Tribiology Online* 2008; 3(2):127-130.
- Lindelof B, et al. *Arch Dermatol* 1988; 124:1359.
- Orwin DFG. In: Rogers, et al. eds. *Biology of Wool and Hair*. Chapman and Hall, 1989:229.
- Randebrook RJ. *J Soc Cosmet Chem* 1964; 15:691.
- Thibaut S, et al. *Int J Dermatol* 2007; 46(suppl 1):7-10.
- Thibaut S, et al. Human hair shape, characterization: from hair bulb to hair fiber. Presented at the Fourth International Symposium On Ethnic Hair & Skin. Miani, November 9-11, 2007.
- Trotter M, Dawson HL. The hair of French Canadians. *Am J Phys Anthropol* 1934; 18:443.
- Yin NE, Kissinger RH, Tolgyesi WS, et al. *J Soc Cosmet*.

## Dandruff and seborrheic dermatitis

James R. Schwartz, Caroline W. Cardin, Yvonne M. DeAngelis, and Thomas L. Dawson, Jr.

### INTRODUCTION

The formation of large, individually distinguishable flakes of skin on the scalp is considered an abnormal condition (1). These flakes are dislodged by mechanical action and are visible either within the hair array or on horizontal surfaces immediately below the hair such as shoulders and top of the back. This condition is known by a number of equivalent names, each having slightly different connotations. The most common, yet not very descriptive, name is "dandruff." "Seborrheic dermatitis" describes essentially the same condition with an emphasis on excessive oiliness (seborrhea) and irritation/redness (dermatitis) (2). Names reflecting the fungal causality (though none of them correctly termed based on today's knowledge, see below) are captured in "pityriasis simplex" and "pityriasis capitis" (referring to *Pityrosporum*) and "furfuracea" (referring to *Malassezia furfur*). All of these terms are in common use today, the practitioner and diagnostician simply need to understand they represent the same symptomology based on the same causes and prescribe treatments as summarized below (2).

### CLINICAL FEATURES

Normal scalp has few flaking areas (Fig. 29.1A) and healthy appearing, smooth skin. Dandruff is characterized by patches of loosely adherent oily flakes, often accompanied by pruritus. Dandruff has the clinical feature of small white or gray flakes that accumulate diffusely on the scalp surface or in localized patches (Fig. 29.1B). Also, dandruff does not exhibit the overt inflammation seen in seborrheic dermatitis and is confined to the scalp.

In seborrheic dermatitis subjects, the scales are greasy and yellowish in color (Fig. 29.1C). Seborrheic dermatitis flakes accumulate in adherent mounds on the scalp, and underlying inflammatory changes (seen as surface erythema) are evident. The lesions of seborrheic dermatitis vary in appearance, with the characteristic presentation being patches of red, flaking, greasy skin, particularly on the scalp, nasolabial folds, ears, eyebrows, and chest. However, patients often vary with respect to the degree of erythema, amount of flaking, and the extent to which the affected areas have a greasy appearance. It is also important to note that while patients with seborrheic dermatitis may have oily skin, this is not necessarily the cause (3–5).

Recently, it has been demonstrated that the unhealthy skin state associated with dandruff and seborrheic dermatitis has negative consequences to the quality of hair (6). Hair from dandruff and seborrheic dermatitis scalp is thinner, has a more brittle surface, and is less shiny than hair from a normal scalp. These observations are very similar to those associated with scalp psoriasis.

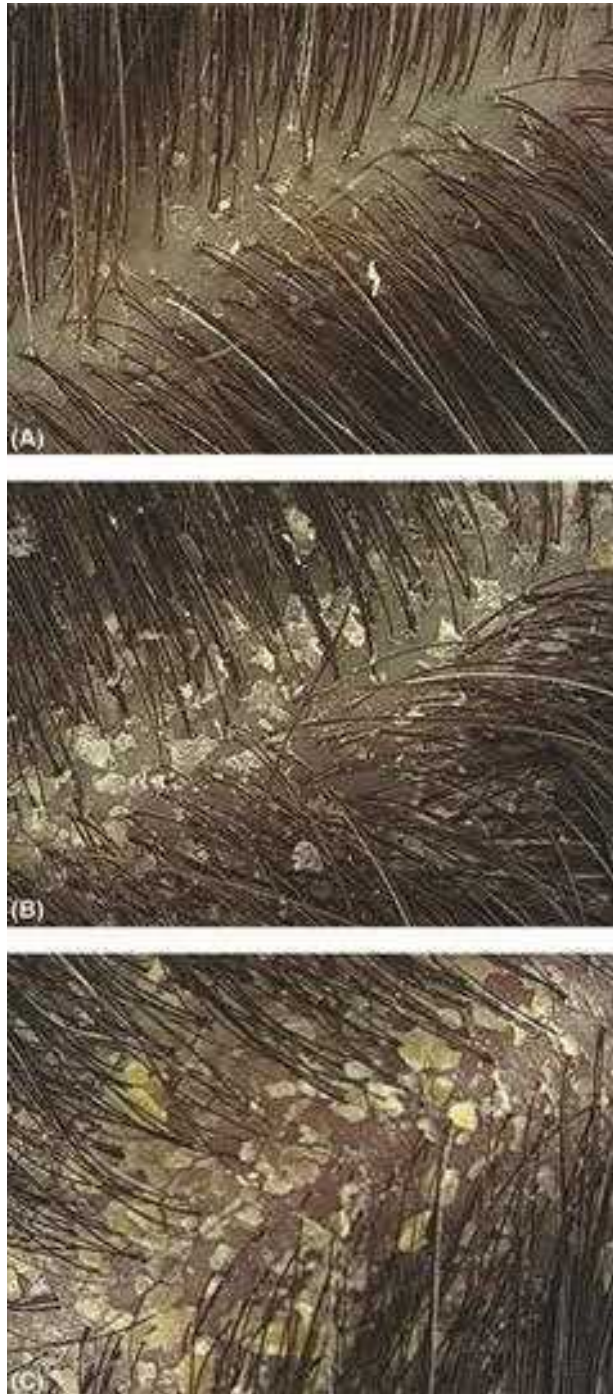
### PREVALENCE

Dandruff and seborrheic dermatitis are the most common scalp afflictions of adolescence and adult life but are considered relatively rare and mild in children (1,2,4). Historically, it was thought that about 50% of the world's population is afflicted to some degree with onset at puberty and peak incidence and severity reached at the age of about 20 years. Dandruff becomes less frequent after the age of 50 years (1,2). A recent survey of 1408 Caucasians, African Americans, and Chinese from Minnesota and Georgia, the United States and Beijing, Shanghai and Guangzhou, and China suggests that severity and prevalence of noticeable dandruff and seborrheic dermatitis are much higher in adult population than first thought at 81% to 95% in African Americans, 66% to 82% in Caucasians, and 30% to 42% in the Chinese (Table 29.1, Fig. 29.2A) (5). Additionally, the prevalence of dandruff was as high in U.S. teens as their adult counterparts with prevalence at 75% to 95% in Caucasian and African American teens (Table 29.1, Fig. 29.2B) (7,8). On the basis of this survey, dandruff occurs in 60% to 90% and seborrheic dermatitis in 3% to 5% of immunocompetent adults. In AIDS patients, the prevalence of seborrheic dermatitis increases to 30% to 33% (9).

Dandruff appears to have little variation due to climate, as incidence and severity are similar from North to South of the United States and China during the winter (Fig. 29.3) (7,8). Higher shampooing frequency appears to result in lowered dandruff severity in all populations (Fig. 29.4) (8). However, when examining population statistics, the frequency of antidandruff product use needs to be taken into account. Despite higher shampoo frequencies and the ready availability of highly effective over-the-counter and prescription antidandruff shampoos in the United States, the most recent prevalence study in both adults and teens suggests dandruff is occurring at a much higher rate and severity than initially thought in the United States versus China (8). The higher prevalence of dandruff in the United States is most likely associated with the lower use of antidandruff shampoo in routine hair care regimen in the United States (10–20%) versus China (40–52%) (Fig. 29.5). In addition, this study demonstrated that scalp itch, the key symptom of dandruff and seborrheic dermatitis, was found to be correlated with the severity of dandruff flaking across all ethnic groups. Dandruff has recently received much attention as its presence can lead to loss of self-esteem and a negative social image (5,8,10).

### PATHOLOGY

The superficial flaking and redness that are the outward symptoms of dandruff and seborrheic dermatitis are manifestations of an abnormal epidermal structure and function (11). Flakes are generally believed to occur in "patches" on the scalp



**Figure 29.1** Clinical features of normal (A), dandruff (B), and seborrheic dermatitis (C) scalp.

and for these eruptions to randomly “move” about on the surface over time. However, the underlying stratum corneum irregularities occur throughout the scalp of affected individuals (11), suggesting the actual flakes are the end result of a cycle of skin distress that may or may not be visible to the unaided eye.

The stratum corneum of affected individuals shows striking features consistent with a hyperproliferative state, as is

**Table 29.1** Adherent Scalp Flaking Severity Scores in Adult and Teens in the United States and China

	Adults	Teens
African American females	29.3	27.1
African American males	23.4	26
Caucasian females	22.7	22.8
Caucasian males	21.3	23.7
Chinese females	12.1	12.4
Chinese males	13.6	11.2

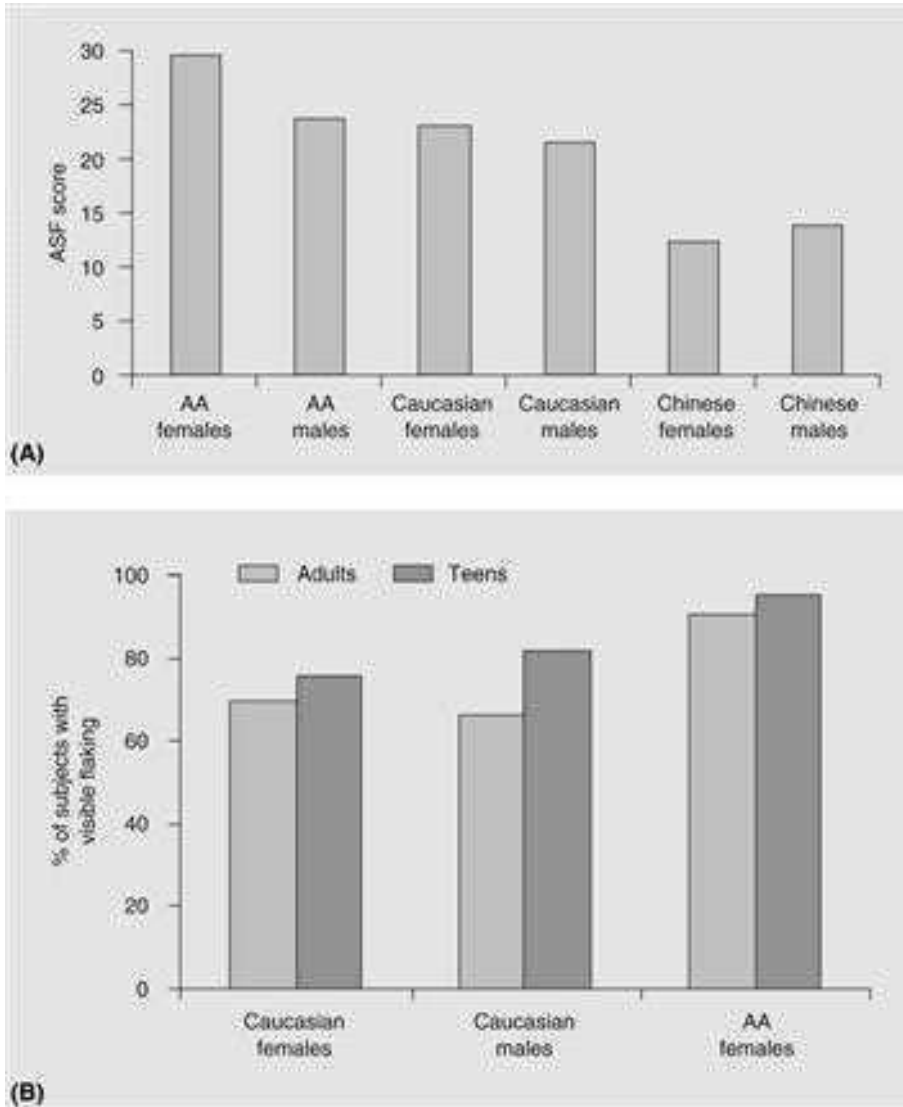
indicated by functional studies that measure accelerated epidermal maturation times (2). The physical features accompanying this state are dramatic (4,5). An electron microscopic study of stratum corneum using new fixation methods (11) reveals that dandruff stratum corneum exhibits parakeratotic nuclei, lipid droplets within corneocytes, a decreased number of desmosomes, irregular corneocyte envelope structure, intercellular *Malassezia* yeasts, and massive quantities of unstructured intercellular lipid (Fig. 29.6). All of these features are consistent with a state in which the feedback between epidermal synthesis and maturation rate is lost and uncontrolled growth leads to corneocytes reaching the surface that are immature and not ready to be shed as individual cells.

The intercellular lipid abnormalities are quite striking in their size as well as lack of tightly ordered lamellae. As expected, there is a lack of true intercellular lipids (ceramides) with most of the lipids being sebaceous in origin (12). Again, this is indicative of the lack of an ordered temporal chain of events, resulting in low epidermal lipid secretion into the intercellular space. Simply topically applying such lipids is unlikely to be meaningful as they cannot displace the sebaceous lipids present nor will initiate the formation of missing features such as a tight lamellar structure or desmosomes and the other characteristics required for orderly desquamation.

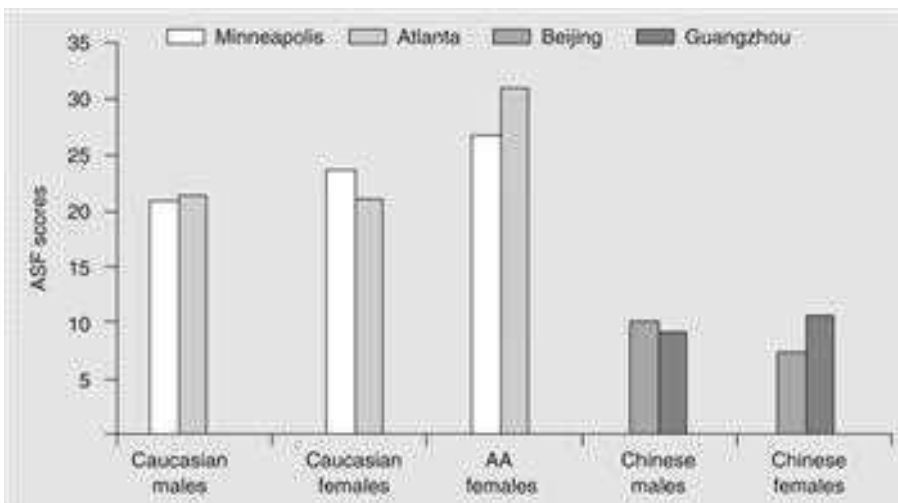
Treatment of dandruff and seborrheic dermatitis will be discussed in the following text, but it is appropriate to mention here that as the outward symptom of flakes is improved, the underlying skin condition is also being restored (11). There is a direct correlation between clinical flaking and the severity of the stratum corneum abnormalities, suggestive of the cause and effect relationship between the superficial (flaking) and sub-surface (morphology) symptoms.

## ETIOLOGY

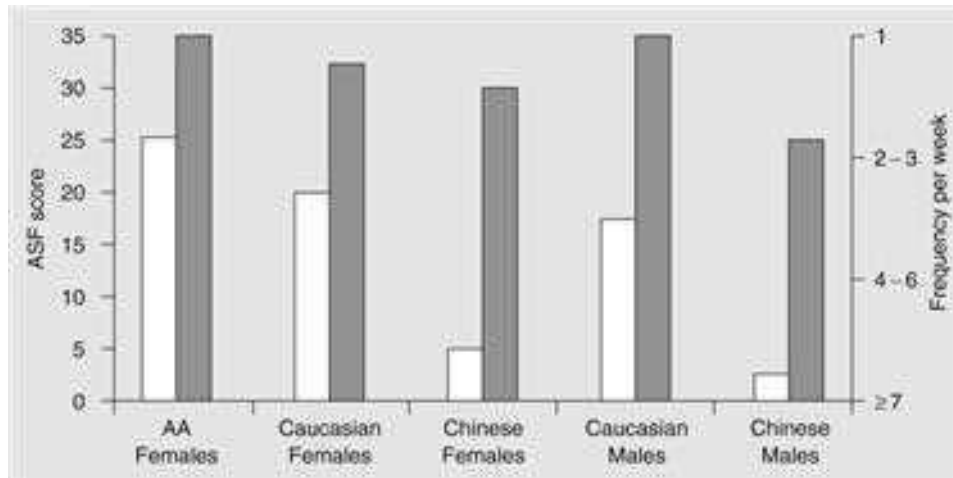
The relationship between dandruff and seborrheic dermatitis has at times been controversial. While most investigators regard seborrheic dermatitis of the scalp as severe dandruff, others believe that dandruff should be used to describe any flaking of the scalp (13–16). The microbial origin of dandruff centers on the causal role of yeasts of the genus *Malassezia* (17,18). Originally named *Malassezia* by Malassez in 1898 (19,20), this genus was renamed and referred to as *Pityrosporum* during the second half of the 20th century (21,22). In the mid-1990s, studies of the morphological, ultrastructural, physiological, and genomic differences of the genus *Malassezia* led to the identification of the following seven species: *M. furfur* (*Pityrosporum ovale*), *M. pachydermatis*, *M. sympodialis*, *M. globosa* (*P. orbiculare*), *M. obtusa*, *M. restricta*, and *M. slooffiae* (23,24). Recently, there have been five additional *Malassezia* spp. described, *M. dermatis* (25), *M. equi* (26), *M. nana*, *M. yamatoensis*



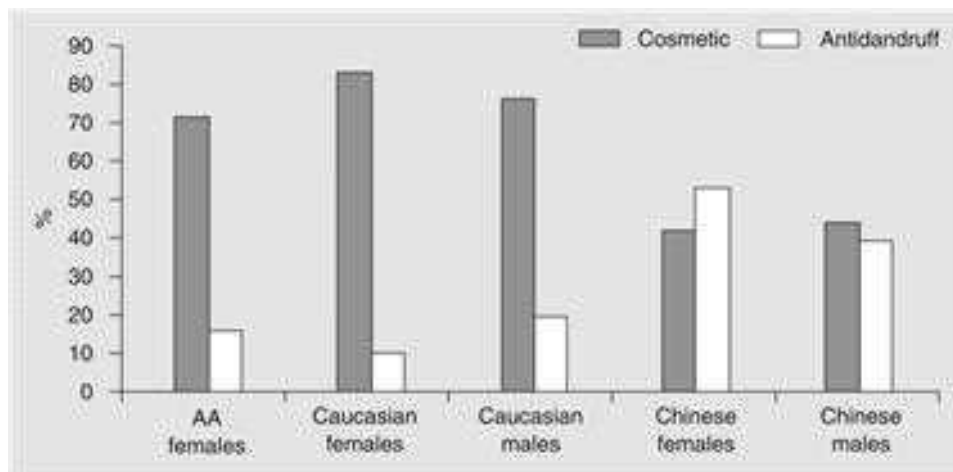
**Figure 29.2** Dandruff incidence among ethnic groups and teens. **(A)** Adherent scalp flaking (ASF) scores in African Americans (AA), Caucasians, and Chinese. **(B)** Dandruff incidence as high in teens as in adults.



**Figure 29.3** Dandruff severity across climatic conditions. *Abbreviations:* ASF, adherent scalp flaking; AA, African American.



**Figure 29.4** Adherent scalp flaking (ASF) score (white bars) versus shampoo frequency (shaded bars). Abbreviation: AA, African American.



**Figure 29.5** Cosmetic versus antidandruff shampoo users. Abbreviation: AA, African American.

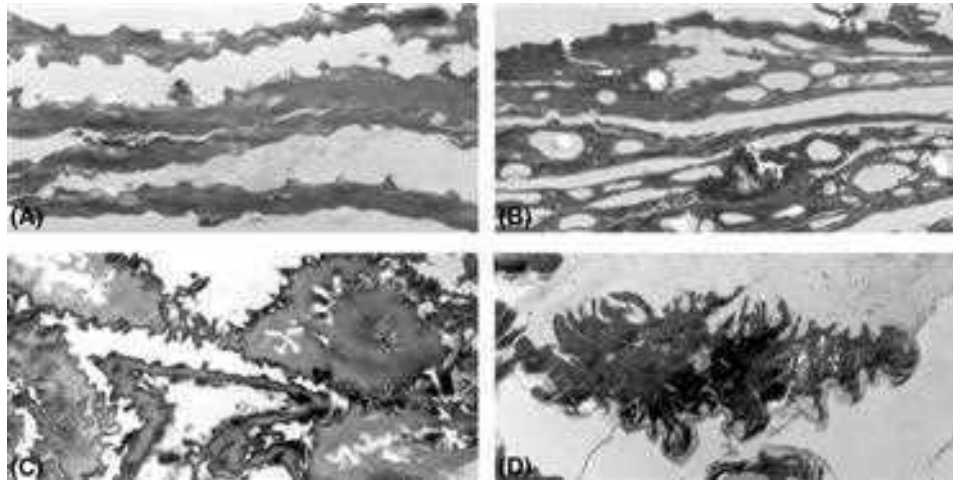
(27), and *M. japonica* (28). As detailed DNA-based identification techniques are more broadly applied to the *Malassezia* genus, there will almost certainly be more species identified.

While the pathogenic role of *Malassezia* as the principal causative agent of dandruff and its association with disease severity has been reported (15,17,18,29,30,31), it was a novel molecular biological technique using terminal fragment length polymorphism (tFLP) analysis that identified *M. globosa* and *M. restricta* as the predominant fungal species present on scalps of both dandruff (flaking scores of >24) and normal (flaking scores of <10) scalps (Fig. 29.7) (32–34). *M. furfur* (*P. ovale*) was absent on human scalps. Though *M. furfur* was the predominant species previously identified using culture techniques (34–36), it is not the species present in vivo. This suggests that *M. furfur* is likely not the causal organism for dandruff, and perhaps is an artifact of isolation or culture techniques, or

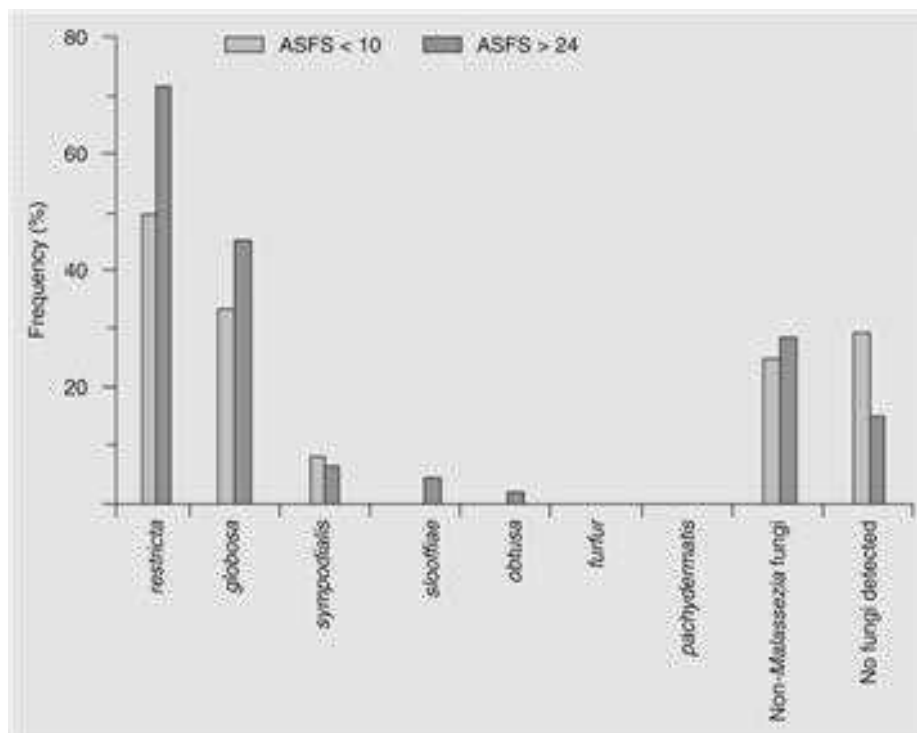
use of supplanted nomenclature. It is important to note that in the 1950s to 1990s, the entire *Malassezia* genus was referred to as *M. furfur* (21,22), and only in the 1990s was the species *M. furfur* split into the genus *Malassezia* with multiple unique species (23,24). The species that retained the name *M. furfur*, while the most robust in culture and likely the most pathogenic, is very rarely isolated from normal human skin (32,37). More recent molecular genotype analyzes the *Malassezia* microflora on skin of atopic dermatitis, and seborrheic dermatitis patients support the presence of *M. globosa* and its likely involvement in disease expression (19,38–40).

Increased interest in the role of *Malassezia* yeasts in the development of dandruff and seborrheic dermatitis has provided additional evidence that in most cases dandruff is indeed a mild form of seborrheic dermatitis. The vast majority of recent data supports a direct causal link between *Malassezia* fungi and





**Figure 29.6** Stratum corneum features in dandruff. (A) Normal scalp. Note the closely apposed cells, flat, solid cell morphology, and close junctions between cells. (B–D). Dandruff scalp. Note the lipid droplets between cells (B), interdigitated cell membranes (C,D), parakeratotic nuclei (D), and vast amount of extracellular lipid (D).



**Figure 29.7** *Malassezia* sp. on human scalp. Abbreviation: ASFS, adherent scalp flaking score.

dandruff. First, effective treatment of the condition can occur with a wide range of material types, from zinc and selenium salts to highly specific azoles, with the only known functional link between these materials being antifungal activity (18). The second supporting factor is that improvement in dandruff correlates exquisitely with reduction in scalp *Malassezia* level

(33,41). While the absolute level of *Malassezia* correlates less well with the dandruff, its reduction, among those individuals that express the symptoms, strongly supports its role.

Recent identification of *M. globosa* as a lipophilic *Malassezia* sp., which is on the scalp and capable of digesting sebaceous triglycerides (33), thereby releasing free fatty acids (oleic

acid) led to the hypothesis that these fatty acids penetrate the stratum corneum and break down skin barrier function (42). This barrier breakdown results in hyperproliferation as well as the secretion of more sebum, which then acts as food to sustain further *Malassezia* proliferation (33). Confirmation of the role of fatty acids in dandruff genesis is proven by the demonstration of oleic acid-induced dandruff-like flaking when applied to scalps of dandruff-susceptible human subjects in the absence of *Malassezia* (33). The resurgence in interest in *Malassezia* biology has also resulted in the sequencing of the *M. globosa* and *M. restricta* genomes (43). Key findings include confirmation of many lipase genes and their expression on scalp, as well as proteomic identification of many other enzymes, which would be detrimental to scalp and hair. For example, there were 24 proteases identified, more than half of which were shown to be expressed on human scalp. Also, multiple genes for generation of peroxides were identified, making it likely that *Malassezia* are involved in damage to the hair shaft as well as the scalp. This hypothesis is also supported by recent work indicating that hair sampled from dandruff sufferers was less healthy than that isolated from nondandruff subjects (44).

Since both *M. globosa* and *M. restricta* are found in dandruff and normal scalps (32), the host immune system may have a role in manifestation of this scalp disorder. Why some individuals get dandruff and others do not, with similar absolute levels of *Malassezia*, will require further research into individual susceptibility.

Investigation of molecular markers and precursors of skin inflammatory, immunologic, and infectious processes in normal and dandruff and seborrheic dermatitis scalps indicate that skin cellular immunity is involved in this scalp disease process (45). Significantly higher levels of IL-1 $\alpha$ /TP (total protein) levels ( $p = 0.03$ ) and IL-1 $\alpha$  to IL-1 $\alpha$  ratios were recovered from dandruff ( $p = 0.07$ ) and seborrheic dermatitis ( $p = 0.002$ ) scalps versus the scalps of normal subjects (Fig. 29.7). The IL-1 $\alpha$  and the IL-1 $\alpha$  to IL-1 $\alpha$  ratios correlated with scalp flaking severity in the diseased versus the non-diseased scalps. The TNF $\alpha$ /TP levels recovered from dandruff scalps were significantly higher ( $p = 0.02$ ) than those recovered from the seborrheic dermatitis and normal scalps. IL-2/TP was significantly increased ( $p = 0.01$ ) and IFN- $\gamma$  and NO levels were significantly decreased ( $p = 0.05$ ) in seborrheic dermatitis versus normal scalps (28). Recent work shows that pyrithione zinc (PTZ) has the ability to abate surfactant-induced IL-1 expression (46).

## ANTIDANDRUFF ACTIVES AND MODES OF ACTION OF ACTIVES

Multiple topical agents identified in the last several decades have proven to be successful therapies for the treatment of dandruff and seborrheic dermatitis. These agents include PTZ (11,13,47–61), selenium sulfide (13,47–52), salicylic acid (47), sulfur (47), coal tar (47,62), hydrocortisone (47) and ketoconazole (13,51,52,57,59,61,63–77) in the United States. In addition, ciclopirox olamine and climbazole are approved antidandruff actives in other countries. A consistent mode of action of all effective actives is their antifungal activity against *Malassezia*. In vitro fungistatic and fungicidal tests of ketoconazole (11,13,51,52,66,67), PTZ (11,13,51,52,57), and selenium disulfide (11,13,51,52,57) have demonstrated extremely low minimum inhibitory concentrations of growth (MICs) against *M. furfur* as the marker organism (11). Coal tar (65) was also demon-

strated to possess activity against 54 *Malassezia* strains isolated from patients with dandruff, seborrheic dermatitis, and pityriasis versicolor, but with a much lower potency. Other antimycotic agents such as itraconazole, terbinafine, bifonazole, climbazole, fluconazole, clotrimazole, dithranol, and liquor carbonis also have the ability to inhibit *P. ovale* (presumed to be *M. furfur*, due to culture conditions) (52,66).

Salicylic acid, sulfur, and liquor carbonis possess exfoliative qualities expected to improve the appearance of scaling, while the antimitotic effect of topical corticosteroids and coal tars might also be involved in reducing the hyperproliferation associated with dandruff scaling.

Traditionally, non-scalp seborrheic dermatitis has been treated with either topical or oral steroids (41). However, the renewed interest in the role of *Malassezia* yeasts and the known side effects of topical steroids have made antifungal medications an increasingly popular choice. Tacrolimus has been shown to have potent antifungal activity against *M. furfur* in vitro (78). It has been suggested that topical tacrolimus and pimecrolimus may be superior alternatives to corticosteroids, as they exhibit anti-inflammatory activity but do not have the side effects associated with long-term corticosteroid use (79). Further, tacrolimus and pimecrolimus may be effective and their effectiveness may be increased as they possess both anti-inflammatory and antifungal activities.

The fungal etiology of both dandruff and seborrheic dermatitis leads to a refractory condition. *Malassezia* yeasts are commensal microflora, so cessation of antifungal therapy will result in a return of the condition. When considering any topical therapy for long-term prophylaxis, particularly when concerning hair, it must be cosmetically acceptable enough to assist in compliance. This highlights that for dandruff and scalp seborrheic dermatitis the use of cosmetic antidandruff shampoos should be the first choice, with less cosmetically acceptable shampoos, lotions, and foams reserved for use in severe or refractory cases (80,81).

## THERAPIES AND EFFICACY

The objective of treatment of dandruff and seborrheic dermatitis is to control the scalp condition at the lowest possible cost and inconvenience to the patient (1,62,80,81). Since the 1960s, various shampoos, conditioners, and treatment products have been marketed as over-the-counter or prescription products for the treatment of seborrheic dermatitis and dandruff. Many of these products not only treat the scalp but can also provide hair grooming needs for cleansing and conditioning hair (11). The importance of antidandruff hair care products with no trade-offs in aesthetics is extremely important for effective therapy because they can be incorporated into a routine hair care regimen and lead to high patient compliance (11,62).

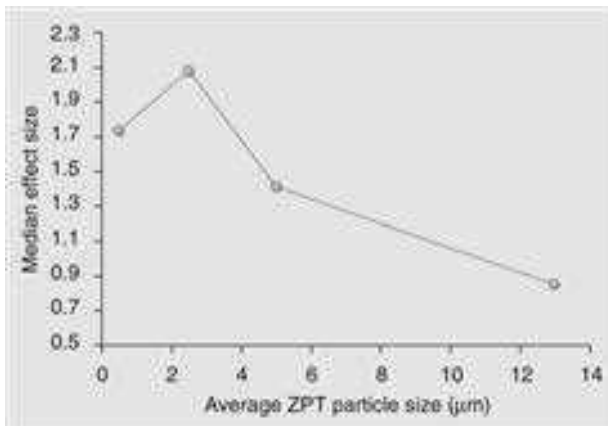
Therapies considered to be effective include PTZ (11,13,47–61), selenium sulfide (47–50,54,58,63,64,82), salicylic acid (4,5,47), sulfur (4,5,47), coal tar (4,5,48), hydrocortisone (41), and ketoconazole (13,51,52,57,61,63–77,83) in the United States. In addition, ciclopirox olamine (47,48), piroctone olamine (84), and climbazole (66) are approved for use in other countries. A consistent mode of action of most of the actives is their antifungal activity against *Malassezia* (13,18).

PTZ shampoo and conditioning rinse-off products have been marketed since the 1960s. This category of antidandruff products has been approved for over-the-counter use in the United States for the treatment of dandruff and seborrheic

**Table 29.2** Optimization of Active Particle Size Increases Dandruff Efficacy of Marketed 1% PTZ Shampoos

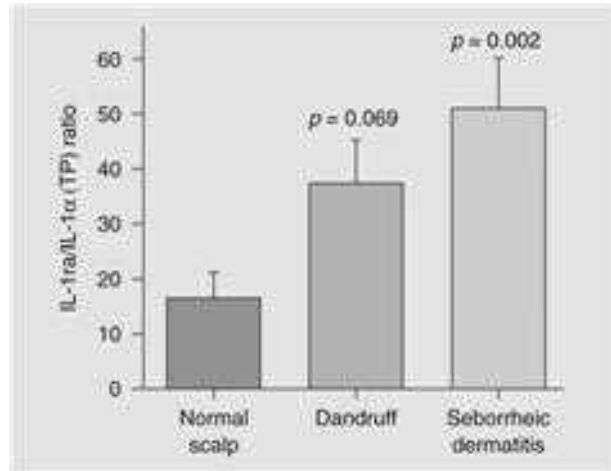
1% PTZ shampoo	Avg. particle size ( $\mu\text{m}$ )	Median effect size	Range of effect sizes
Shampoo A	13	0.85	1 study only
Shampoo B	5	1.41	[1.36, 2.93]
Shampoo C	2.5	2.08	[0.55, 2.14]
Shampoo D	0.5	1.74	1 study only

Individual effect sizes are standardized mean differences between active and placebo shampoos of the reduction in scalp flaking after six weeks of use. The results were taken from 14 separate studies. Since some PTZ shampoos appeared together in the same study, the effect sizes were computed accounting for the correlation and for unequal variances.

**Figure 29.8** Effect of particle size is a significant variable in PTZ-based product efficacy. Note that, in practice, products containing 2.5  $\mu\text{m}$  platelet PTZ appears to be most effective.

dermatitis at levels of 0.3% to 2% PTZ in shampoo and rinse-off products (47–50), and 0.1% to 0.25% PTZ in conditioner and leave-on products (49,50). The efficacy of these products has been demonstrated in many clinical trials (13,21,47–52,63). While PTZ possesses high intrinsic microbial inhibitory activity against *Malassezia* (21,47–52), its practical efficacy is dependant on shape and particle size. These parameters can be optimized to maximize scalp surface coverage and deliver optimal efficacy. For example, platelet PTZ at a particle size of 2.5  $\mu\text{m}$  is optimal for deposition on scalp from shampooing as well as provides scalp surface coverage (Table 29.2, Fig. 29.8) (11).

For antidandruff products containing particulate actives such as PTZ, the antidandruff efficacy would be expected to be effected by the size and shape of those particles. These latter factors will affect the amount of active deposited on the scalp (also impacted by the product matrix itself), the persistence of the deposit during rinsing, and the degree of coverage on the scalp surface. The authors have compiled data from 14 separate clinical studies involving antidandruff shampoos with 1% PTZ of different average particle size. To gauge the impact of particle size, the median effect size was evaluated relative to placebo as measured by the standardized mean differences of the reduction in scalp flaking after six weeks of product use (since some PTZ shampoos appeared together in the same

**Figure 29.9** Ratio of interleukin (IL)-1ra/IL-1 $\alpha$  normalized to total protein (TP) in normal scalps and scalps of dandruff and seborrheic dermatitis sufferers. Values are mean  $\pm$  SE.

study, the effect sizes were computed accounting for the correlation and for unequal variances). The results are represented graphically in Figure 9. It can be seen that particle size is a significant variable in PTZ-based product efficacy and that not all PTZ-based shampoos can be assumed to work equivalently. In practice, products containing 2.5  $\mu\text{m}$  platelet PTZ appear to be most effective (11,85,86).

*Selenium sulfide* has been approved for over-the-counter use for the treatment of dandruff and seborrheic dermatitis at levels of 0.6% (micronized form) and 1% (47–50). Shampoos containing selenium sulfide have proven efficacy (15,30,31). Since selenium sulfide is a particulate, efficacy is dependent on the particle size to optimize coverage. Differences in efficacy may be related to the particle size of the selenium sulfide in the shampoo. Further, selenium sulfide is a complex mixture of multiple isoforms, and the relative constitution of formulations affect efficacy.

*Ketoconazole*, an imidazole antimycotic agent, has been used orally for the treatment of mycoses. Several large antidandruff efficacy studies have demonstrated efficacy against pityriasis capitis and seborrheic dermatitis (15,18,30,31,47–50). Ketoconazole has been approved for topical over-the-counter use at 1% in shampoos and prescription use at 2%. Twice weekly treatments are currently recommended for ketoconazole-containing shampoos. To achieve efficacy, these products are recommended to be left on the scalp for 5 to 10 minutes before rinsing thereby requiring a change in shampooing habits and practices.

*Coal tar*, approved for over-the-counter treatment of dandruff, seborrheic dermatitis, and psoriasis at levels of 0.5% to 5% (tar equivalent) (47–50), reduces the number and size of epidermal cells, decreases epidermal proliferation, and dermal infiltrates. Coal tar has also been reported to have slight antifungal activity, which could explain its limited antidandruff efficacy (47–50,62). Coal tar-containing shampoo and treatment products have been marketed for decades mainly for psoriasis. This shampoo has been anecdotally reported to negatively impact hair color.

*Salicylic acid*, approved for over-the-counter treatment of dandruff, seborrheic dermatitis, and psoriasis at concentrations of 1.8% to 3% (47–50), is an exfoliative agent that loosens the scales, enabling them to be washed away. Sulfur is approved for over-the-counter treatment of dandruff at levels of 2% to 5%. Combinations of salicylic acid and sulfur have not been approved for over-the-counter use in the United States.

*Climbazole*, an antimycotic agent present in antidandruff shampoos in the European continent with high in vitro and in vivo efficacy against *Malassezia*, was evaluated for efficacy and safety (85). This shampoo is not marketed in the United States.

## COMPARATIVE EFFICACY OF ANTIDANDRUFF THERAPIES

### Ketoconazole vs. PTZ

Comparison of optimized PTZ and ketoconazole products has demonstrated equivalent performance. As discussed in the preceding text, it is important to consider the particle size of the PTZ contained in each product, as optimized PTZ particles have been shown to have increased performance. The relative antidandruff efficacy of a 1% size-optimized PTZ particle-containing shampoo has been compared to 1% and 2% ketoconazole shampoos (11,57,61). In a three hundred and sixty-four patient, six-week, randomized, double-blind, parallel group study (57), three groups of 112 patients were assigned a 1% PTZ shampoo, or a 1% PTZ shampoo with a different use regimen, or a 2% ketoconazole shampoo, and a fourth group of 28 patients was assigned to a placebo shampoo. The antidandruff efficacy of the two 1% PTZ shampoos, regardless of the use regimen, was found to be comparable to the 2% ketoconazole shampoo. All three active treatments were significantly more efficacious than the placebo shampoo. In a small 60-patient, 8-week, randomized, double-blind, parallel group study (58), a 1% ketoconazole shampoo was found to be more efficacious than a 1% nonoptimized large particle PTZ-containing shampoo after six and eight weeks of therapy in a subpopulation of patients with severe dandruff. The differences observed in this study are attributed to a shampoo with a larger nonoptimum particle size PTZ and therefore less efficacious than some of the currently marketed PTZ shampoos.

In a recent clinical study (59), the efficacy of 2% ketoconazole shampoo was compared to a 1% nonoptimized PTZ shampoo in severe dandruff and seborrheic dermatitis sufferers. This randomized parallel group study in a total of 341 sufferers consisted of a two-week run period with a neutral non-antidandruff shampoo, followed by four weeks of active treatment with either 2% ketoconazole twice weekly or 1% PTZ shampoo at least twice weekly and a subsequent four-week follow-up phase on nonactive shampoo. While significant benefits were observed for both shampoos in comparison to nondandruff shampoos, the 2% ketoconazole shampoo achieved a 73% improvement in total dandruff severity scores compared to 67% improvement for 1% PTZ shampoo at week 4 of active treatment. These differences were significant at  $p = 0.02$ . Side effects were minimal. Efficacy differences observed in this study were attributed to a shampoo with a larger particle size PTZ, and therefore less efficacious product than currently marketed PTZ shampoos.

In a post-marketing study examining the efficacy of a combination shampoo containing 2% ketoconazole and 1% PTZ (61), greater than 90% reduction in dandruff severity was observed for all areas of the scalp for in 236 moderate to

severe dandruff sufferers in four weeks of treatment. In addition to the significant reduction in dandruff severity, improvements in erythema and pruritus and minimal side effects were observed. This combination shampoo while offering a safe and effective option for the treatment of dandruff in India and perhaps other geographies is not approved for use in the United States.

### Ketoconazole vs. Selenium Sulfide

In a comparative efficacy study of a 1% selenium sulfide shampoo versus a 2% ketoconazole shampoo (63), a 1% selenium sulfide shampoo was found to be more effective than the 2% ketoconazole shampoo after 4 weeks of therapy. This was a large 350, 6-week, double-blind, randomized parallel group study where two groups of 150 patients, with moderate to severe dandruff or seborrheic dermatitis, were randomly assigned to either 1% selenium sulfide shampoo or 2% ketoconazole shampoo, and one group of 50 patients was randomly assigned to placebo shampoo. Adherent scalp flaking scores were assessed at baseline and weeks 2, 4, and 6. Both the 1% selenium sulfide shampoo and the 2% ketoconazole shampoo were significantly more efficacious than the placebo shampoo at all treatment time points. While the efficacy of these shampoos was comparable at week 2, the 1% selenium sulfide shampoo was found to be significantly more effective at reducing adherent scalp flaking in comparison to the 2% ketoconazole shampoo after four and six weeks of therapy. The superior efficacy associated with the 1% selenium sulfide shampoo may be a function of the shampoo frequency. When the hair was shampooed three times weekly, patients using the 1% selenium sulfide shampoo had significantly better improvement than patients using the 2% ketoconazole shampoo. When the shampoo frequency was comparable at two times per week, the efficacy of the two active products was comparable.

In a four-week study (63), 246 patients with moderate to severe seborrheic dermatitis and dandruff used a 2% ketoconazole shampoo, a 2.5% selenium sulfide shampoo, or a placebo shampoo twice weekly for four weeks. Both active shampoos produced significant improvement in total adherent dandruff scores relative to the placebo shampoo. The 2% ketoconazole shampoo was found to be significantly better than the 2.5% selenium shampoo after one week, but not after two and four weeks of therapy. Assessments of the reduction in yeast cell counts paralleled the adherent flaking results with the ketoconazole and selenium sulfide shampoos having significantly reduced yeast cell counts relative to placebo treatment. Following the active treatment phase, 103 patients who responded to treatment entered the regression phase, where they used a nonmedicated shampoo for an additional three weeks. A progressive increase in adherent and loose dandruff scores and an increase in the percentage of patients with yeast colonization were noted indicating relapse on cessation of therapy.

In a four-week, double-blind study (68), 102 patients with moderate to severe dandruff were shampooed at the test facility with a 2% ketoconazole shampoo, a 2.5% selenium sulfide, or placebo shampoo twice weekly for four weeks. Adherent scaling and yeast organism density were assessed at pre- and two and four weeks post treatment. The 2% ketoconazole shampoo was comparable to the 2.5% selenium sulfide shampoo in flaking reduction scores, and both active shampoos were significantly more effective than the placebo shampoo. The

mean yeast count reduction scores paralleled the flake reduction efficacy measures, with the 2% ketoconazole and 2.5% selenium sulfide shampoos producing a significantly higher reduction in yeast density than the placebo shampoo.

### Coal Tar, Selenium Sulfide, and PTZ

In a study comparing the activity of a 1% selenium sulfide commercial shampoo with two commercial shampoos containing 1% PTZ and one product containing coal tar (40,54), loose, adherent, and total dandruff flake scores were obtained. The study was conducted among 199 panelists for four weeks. Most clinical evaluations focus on the adherent scalp flakes; thus, this data is referred to here. The change versus baseline at four weeks was as follows: selenium sulfide, 7.1; PTZ prototype A, 7.0; PTZ prototype B, 5.7; and coal tar, 5.8. Coal tar does not appear to have substantial antidandruff activity and, as has been seen previously, PTZ-based products can vary considerably in activity depending on pharmacological delivery of the active.

### Other Actives and Combinations

In a recent trial, the efficacy of a 1.5% ciclopirox olamine and 3% salicylic acid shampoo was compared to 2% ketoconazole in a study with 224 (154 dandruff and 70 seborrheic dermatitis) subjects (80). The shampoos were used three times weekly for a period of four weeks followed by a two-week follow-up period. Clinical and self-assessments of efficacy were made. Both treatments produced significant improvement with lower clinical and self-assessment scores observed at the end of treatment and follow-up periods. Only subjects treated with 1.5% ciclopirox olamine and 3% salicylic acid shampoo showed a significant reduction in scalp itching in the seborrheic dermatitis subjects.

A recent randomized double-blind study was conducted in two groups of 30 moderate to marked dandruff sufferers with a nontar (2% salicylic acid, 0.75% piroctone olamine and 0.5% elubiol) or 0.5% coal tar shampoo (88). The study consisted of a three-week run-in washout period, followed by a four-week treatment and a four-week post-treatment regression phase. The nontar shampoo was found to reduce *Malassezia* spp. counts and squamometry values versus the 0.5% tar shampoo. However, the nontar shampoo contained two antifungal agents, namely piroctone olamine and elubiol and a keratolytic agent (89).

The effectiveness of 2% sulfur and 2% salicylic acid either alone or in combination in a shampoo were assessed in a double-blind, parallel controlled study (90) using scaling and corneocyte counts as the end points for efficacy. A total of 48 patients with moderate to severe dandruff were shampooed twice weekly at the study site for five weeks. At weekly intervals, scalp flaking and corneocyte counts were assessed. Significantly greater and earlier reductions in the degree of scaling and corneocyte counts were observed in patients treated with the formula containing 2% sulfur and 2% salicylic acid versus the individual ingredients. This combination active treatment is not approved for marketing in the United States.

In a small (8 patients on selenium sulfide and 15 patients on miconazole nitrate treatment) parallel group study (57), the antidandruff efficacy of a 2.5% selenium disulfide shampoo was compared to a 2% miconazole nitrate shampoo. Miconazole nitrate was found to possess antidandruff activity equivalent

to selenium disulfide. The end point for efficacy determination was clinical assessment of disease severity supplemented by cytodiagnosis of exfoliated scalp epidermal cells by smear examination.

A small, four-week, unblinded, open study (60) reported marked decreases in scaling, seborrhea, erythema, and the burning and itching of the scalp of seborrheic dermatitis patients treated with either a 1% PTZ or a 1% econazole shampoo. The 1% econazole shampoo was assessed to be slightly better than the 1% PTZ shampoo. However, this 1% econazole shampoo is not marketed.

## EFFICACY MEASURES (DERMATOLOGIC AND MICROBIOLOGIC)

The primary efficacy measure of antidandruff activity in clinical trials is adherent scalp flaking severity. This assessment is generally based on an 11-point flaking scale ranging from 0 to 1 (very light scaling) to 8 to 10 (severe scaling) (47,58,59,61, 68–72,75,76,83) or from 0 (no scaling) to 10 (very heavy scaling) (47,53,55,57,63). The scalp is divided into six (47,58,59,61, 68–72,75,76,83) or eight (47,53,55,57,63) anatomic sites, and the adherent density is scored after parting the hair at each anatomical site multiple times. The adherent flaking score from each site is then summed across sites (total of 60 or 80) for the primary efficacy measure. An alternative method, the Colorimetric method (Chroma C\*), called squamometry is used to assess the amount of flakes obtained on D-squame tapes collected from the most severely affected area at pretreatment and the same area at posttreatment to assess flaking density changes resulting from treatment. Corneocyte counting is another alternative method for assessing flaking changes. These two latter methods are not used in the conduct of current clinical studies. In addition to the adherent scalp flaking scores, assessment of loose dandruff, global involvement in the disease process, and subjective assessment of itch and dandruff severity serve as secondary efficacy measures. Other secondary efficacy end points include the assessment of *Malassezia* density (64,68,74). However, these have been superseded by more accurate molecular genetic techniques (33,38–40,91) in species identification and quantification.

## DANDRUFF TREATMENT CONSIDERATIONS

While intrinsic antifungal potency of antidandruff products is important, these therapeutic results can only be achieved if antidandruff shampoos are incorporated into a patient's routine hair care regimen. Despite higher shampoo frequencies and the ready availability of highly effective over-the-counter and prescriptions antidandruff shampoos in the United States, the most recent prevalence study (11,47–50) in both adults and teens suggests dandruff is occurring at a much higher rate and severity than initially thought in the United States versus China (7). The higher prevalence of dandruff in the United States may be associated with the lower use of antidandruff shampoo in routine hair care regimen versus China. This suggests that shampooing more often with antidandruff shampoos that have excellent efficacy, aesthetics and hair conditioning properties similar to cosmetics shampoo could lead to a lower prevalence and severity of dandruff. While most antidandruff shampoos have trade-offs in usage regimen and hair end benefits such as negative odor attributes, unusual color or hair staining properties, or altered use regimen instructions

such as a 5- to 10- minute residence time versus 30 seconds, the norm for shampooing (72), some cosmetic PTZ-containing shampoos have been uniquely formulated to have no significant trade-offs, leaving the hair cleaned and conditioned. Recommendations for more frequent use of antidandruff shampoos with superior cleansing and conditioning properties as a patient's regular hair care regimen may lead to more successful management of dandruff.

Once dandruff and seborrheic dermatitis is brought under control, effective prevention is required to decrease the probability of reoccurrence (which is quite frequent due to the recolonization of *Malassezia*). This requires long-term use of an effective antidandruff product that is also cosmetically desirable and affordable. PTZ-based shampoos have been shown (44) to be effective over long periods of time without the risk of any physiological accommodation (tachyphylaxis) that could gradually reduce the benefits.

## REFERENCES

- Dawber R. Shampoos—scientific basis and clinical aspects. The Royal Society of Medicine Press. International Congress and Symposium Series 216, 1995.
- Dawber R. Isolated dandruff. In: Maibach HI, ed. *Cosmetic Dermatology*. 1st ed. London, England: Martin Dunitz, 1994.
- Broberg A. *Pityrosporum ovale* in healthy children, infantile seborrheic dermatitis and atopic dermatitis. *Acta Derm Venereol Suppl (Stockh)* 1995; 191:1-47.
- Ackerman AB, Kligman AM. Some observations on dandruff. *J Soc Cosmet Chemists* 1969; 81-101.
- Orfanos CE, Happle R. *Hair and Hair Diseases*. 1st ed. Berlin: Springer-Verlag, 1989:641-662.
- Sinclair RD, Schwartz JR, Rocchetta HL, et al. Dandruff and seborrheic dermatitis adversely affect hair quality. *Eur J Dermatol* 2009; 19(4):410-411.
- Hickman JG, Wang X, King B, et al. Dandruff among teens—incidence and fungal speciation characterization. In: American Academy of Dermatology Meeting, 2003.
- Hickman JG, Cardin C, Dawson TL, et al. Dandruff, Part I: Scalp Disease Prevalence in Caucasians, African Americans and Chinese and the Effects of Shampoo Frequency on Scalp Health. In: American Academy of Dermatology Meeting, 2002.
- Farthing CF, Staughton RCD, Rowland Payne CME, Skin disease in homosexual patients with Acquired Immune Deficiency Syndrome (AIDS) and lesser forms of human T cell Leukaemia Virus (HTLV III) disease. *Clin Exp Dermatol* 1985; 10(1):3-12.
- Hay R, Graham-Brown R. Dandruff and seborrheic dermatitis: causes and management. *Clin Exp Dermatol* 1997; 22(1):3-6.
- Warner R, Schwartz JR, Boissy Y, et al. Dandruff has an altered stratum corneum ultrastructure that is improved with zinc pyrithione shampoo. *J Am Acad Dermatol* 2001; 45(6):897-903.
- Harding CR, Moore AE, Rogers JS, et al. Dandruff: a condition characterized by decreased levels of intercellular lipids in scalp stratum corneum and impaired barrier function. *Arch Dermatol Res* 2002; 294(5):221-230.
- Bulmer A, Bulmer G. The antifungal action of dandruff shampoos. *Mycopathologia* 1999; 147(2):63-65.
- Kligman AM. Perspectives and problems in cutaneous gerontology. *J Invest Dermatol* 1979; 73(1):39-46.
- McGrath J, Murphy GM. The control of seborrheic dermatitis and dandruff by antipityrosporal drugs. *Drugs* 1991; 41(2):178-184.
- Pierard Franchimont C, Hermanns JF, Degreef H, et al. From aziums to new insights into dandruff. *Dermatology* 2000; 200:93-98.
- Saint-Leger D. The history of dandruff and dandruff in history. A homage to Raymond Sabouraud. *Ann Dermatol Venereol* 1990; 117(1):23-27.
- Shuster S. The aetiology of dandruff and the mode of action of therapeutic agents. *Br J Dermatol* 1984; 111(2):235-242.
- Sei Y. Seborrheic dermatitis—clinical diagnosis and therapeutic value of different drugs. *Jpn J Med Mycol* 2003; 44:77-80.
- Malassez L. Note sur le champignon du pityriasis simple. *Arch De Physiologie* 1874; 1:451.
- Gordon MA. The lipophilic mycoflora of the skin. I. In vitro culture of *Pityrosporum orbiculare* n. sp. *Mycologia* 1951; 43: 524-535.
- Yarrow D, Ahearn DG. The yeasts. A taxonomic study. In: Kreger-Van Rij NJW, ed. *Genus 7. Malassezia* Baillon. Amsterdam: Elsevier, 1984:882-885.
- Gueho E, Midgley G, Guillot J. The genus *Malassezia* with description of four new species. *Antonie Van Leeuwenhoek* 1996; 69(4):337-355.
- Guillot J, Gueho E, Lesourd M, et al. Identification of *Malassezia* Species. *J Mycol Med* 1996; 6:103-110.
- Sugita T, Takashima M, Shinoda T, et al. New yeast species, *Malassezia dermatis*, isolated from patients with atopic dermatitis. *J Clin Microbiol* 2002; 40(4):1363-1367.
- Nell A, James SA, Bond CJ, et al. Identification and distribution of a novel *Malassezia* species yeast on normal equine skin. *Vet Rec* 2002; 150:395-398.
- Sugita T, Tajima M, Takashima M, et al. A new yeast, *Malassezia yamatoensis*, isolated from a patient with seborrheic dermatitis, and its distribution in patients and healthy subjects. *Microbiol Immunol* 2004; 48(8):579-583.
- Sugita T, Takashima M, Kodama M, et al. Description of a New Yeast species, *Malassezia japonica*, and its detection in patients with atopic dermatitis and healthy subjects. *J Clin Microbiol* 2003; 41(10):4695-4699.
- Gupta AK, Batra R, Bluhm R, et al. Skin diseases associated with *Malassezia* species. *J Am Acad Dermatol* 2004; 51:785-798.
- Leyden J, Kligman AM. Dandruff cause and treatment. *Cosmet Toil* 1979; 94:3.
- Leyden JJ, McGinley KJ, Kligman AM. Role of microorganisms in dandruff. *Arch Dermatol* 1976; 112(3):333-338.
- Gemmer C, DeAngelis YM, Theelen B, et al. Fast, noninvasive method for molecular detection and differentiation of *Malassezia* yeast species on human skin and application for the method to dandruff microbiology. *J Clin Microbiol* 2002; 40(9):3350-3357.
- DeAngelis YM, Saunders CW, Johnstone KR, et al. Isolation and expression of a *Malassezia globosa* lipase gene, LIP1. *J Invest Dermatol* 2007; 127(9):2138-2146.
- Gupta AD, Deangelis YM, Kaczvinsky JR, et al. Application of Novel Molecular Methods to Delineate the Role of Specific *Malassezia* Species in the Etiology of Dandruff. In: American Academy of Dermatology Meeting, 2002.
- Gupta AK, Kohli Y, Faergemang J, et al. Epidemiology of *Malassezia* yeasts associated with pityriasis versicolor in Ontario, Canada. *Med Mycol* 2001; 39(2):199-206.
- Nakabayashi A, Sei Y, Guillot J. Identification of *Malassezia* species isolated from patients with seborrheic dermatitis, atopic dermatitis, pityriasis versicolor and normal subjects. *Med Mycol* 2000; 38(5):337-341.
- Gaitanis G, Velegraki A, Alexopoulos EC, et al. Distribution of *Malassezia* species in pityriasis versicolor and seborrheic dermatitis in Greece. Typing of the major pityriasis versicolor isolate *M. globosa*. *Br J Dermatol* 2006; 154:854-859.
- Sugita T, Kodama M, Saito M, et al. Sequence diversity of the intergenic spacer region of the rRNA gene of *Malassezia globosa* colonizing the skin of patients with atopic dermatitis and healthy individuals. *J Clin Microbiol* 2003; 41(7):3022-3027.
- Sugita T, Nishikawa A. Molecular and quantitative analysis of *Malassezia* microflora on the skin of atopic dermatitis patients and genotyping of *M. globosa* DNA. *Jpn J Med Mycol* 2003; 44:61-64.
- Kawaguchi H, Akiyama K. *Malassezia* and atopic dermatitis. *Nippon Ishinkin Gakkai Zasshi* 2003; 44(2):65-69.
- Johnson B, Nunley J. Treatment of seborrheic dermatitis. *Am Fam Physician* 2000; 61(9):2703-2710, 2713-2714.

42. Ro BI, Dawson TL. The role of sebaceous gland activity and scalp microfloral metabolism in the etiology of common scalp conditions. *J Investig Dermatol Symp Proc* 2005; 10:194–197.
43. Xu J, Saunders CW, Hu P, et al. Dandruff-associated *Malassezia* genomes reveal convergent and divergent virulence traits shared with plant and human fungal pathogens. *Proc Natl Acad Sci U S A* 2007; 104(47):18730–18735.
44. Schwartz JR, Rocchetta H, Asawanonda P, et al. Does tachyphylaxis occur in long-term management of scalp seborrheic dermatitis with pyrithione zinc-based treatments? *Int J Dermatol* 2009; 48(1):79–85.
45. Perkins MA, Cardin CW, Osterhues MA, et al. A noninvasive tape absorption method for recovery of inflammatory mediators to differentiate normal from compromised scalp conditions. *Cosmet Toil* 2004; 119(2):82.
46. Warren R, et al. Attenuation of surfactant-induced interleukin 1 expression by zinc pyrithione. *Exogenous Dermatol* 2003; 2(1):23–27.
47. Food and Drug Administration, H., Dandruff, seborrheic dermatitis and psoriasis drug products for over-the-counter human use. *Fed Regist* 1982; 47(233):54664–54666.
48. Food and Drug Administration, H. Dandruff, seborrheic dermatitis and psoriasis drug products for over-the-counter human use; final monograph. *Fed Regist* 1991; 56(19):63554–63569.
49. Food and Drug Administration, H., Dandruff, seborrheic dermatitis and psoriasis drug products for over-the-counter human use; amendment to the monograph. *Fed Regist* 1994; 59(19):4000–4001.
50. Food and Drug Administration, H., Dandruff, seborrheic dermatitis, and psoriasis drug products containing coal tar and menthol for over-the-counter human use; amendment to the monograph. Final rule. *Fed Regist* 2007; 72(43):9849–9852.
51. Van Cutsem J, Van Gerven F, Franssen J, et al. The in vitro antifungal activity of ketoconazole, zinc pyrithione, and selenium sulfide against *Pityrosporum* and their efficacy as a shampoo in the treatment of experimental pityrosporiasis in guinea pigs. *J Am Acad Dermatol* 1990; 22(6 pt 1):993–998.
52. Nenoff P, Hausteil UF. Effect of anti-seborrhea substances against *Pityrosporum ovale* in vitro. *Hautarzt* 1994; 45(7):464–467.
53. Marks R, Pearse AD, Walker AP. The effects of a shampoo containing zinc pyrithione on the control of dandruff. *Br J Dermatol* 1985; 112(4):415–422.
54. Rapaport M. A randomized, controlled clinical trial of four anti-dandruff shampoos. *J Int Med Res* 1981; 9(2):152–156.
55. Cardin CW, Amon RB, Hanifin JM. The antidandruff efficacy of Head and Shoulders rinse-in shampoo (1% zinc pyrithione) and Head and Shoulders shampoo (1% zinc pyrithione) with Head and Shoulders conditioning rinse (0.3% zinc pyrithione) versus Merit shampoo with Merit Moisture Rinse. *Nishininon J Dermatol* 1990; 52:1208–1216.
56. Rowlands CG, Danby FW. Histopathology of psoriasis treated with zinc pyrithione. *Am J Dermatopathol* 2000; 22(3):272–276.
57. Billheimer W, Bryant PB, Murray KP, et al. Results of clinical trial comparing 1% pyrithione zinc and 2% ketoconazole shampoos. *Cosmet Dermatol* 1996; 9(5):34–39.
58. Cauwenbergh G. International experience with ketoconazole shampoo in the treatment of seborrheic dermatitis and dandruff. in Royal Society of Medicine Services International Congress and Symposium, The Royal Society of Medicine Services Limited, 1988.
59. Pierard Franchimont C, Goffin V, Decroix J, et al. A multicenter randomized trial of ketoconazole 2% and zinc pyrithione 1% shampoos in severe dandruff and seborrheic dermatitis. *Skin Pharmacol Appl Skin Physiol* 2002; 15:434–441.
60. Rigoni C, Toffolo P, Cantù A, et al. [1% econazole hair-shampoo in the treatment of pityriasis capitis; a comparative study versus zinc-pyrithione shampoo]. *G Ital Dermatol Venereol* 1989; 124(11–12):LXVII–LXX.
61. Saple D, Ravichandran G, Desai A. Evaluation of safety and efficacy of ketoconazole 2% and zinc pyrithione 1% shampoo in patients with moderate to severe dandruff—a postmarketing study. *J Indian Med Assoc* 2000; 98(12):810–811.
62. Nenoff P, Hausteil UF, Fiedler A. The antifungal activity of a coal tar gel on *Malassezia furfur* in vitro. *Dermatology* 1995; 191(4):311–314.
63. Neumann P, Coffindaffer T, Cothran P. Clinical investigation comparing 1% selenium sulfide and 2% ketoconazole shampoos for dandruff control. *Cosmet Dermatol* 1996; 9:20–26.
64. Danby FW, Maddin WS, Margesson LJ, et al. A randomized, double-blind, placebo-controlled trial of ketoconazole 2% shampoo versus selenium sulfide 2.5% shampoo in the treatment of moderate to severe dandruff. *J Am Acad Dermatol* 1993; 29(6):1008–1012.
65. Faergemann J, Borgers M. The effect of ketoconazole and itraconazole on the filamentous form of *Pityrosporum ovale*. *Acta Derm Venereol* 1990; 70(2):172–176.
66. Schmidt A, Ruhl Horster B. In vitro susceptibility of *Malassezia furfur* against azole compounds. *Mycoses* 1996; 39(7–8):309–312.
67. Richardson MD, Shankland GS. Enhanced phagocytosis and intracellular killing of *Pityrosporum ovale* by human neutrophils after exposure to ketoconazole is correlated to changes of the yeast cell surface. *Mycoses* 1991; 34(1–2):29–33.
68. Hickman J. Nizoral (ketoconazole) shampoo therapy in seborrheic dermatitis. *J Int Postgrad Med* 1990; 2(1):14–17.
69. Ive FA. An overview of experience with ketoconazole shampoo. *Br J Clin Pract* 1991; 45(4):279–284.
70. Faergemann J. Treatment of seborrheic dermatitis of the scalp with ketoconazole shampoo. A double-blind study. *Acta Derm Venereol* 1990; 70(2):171–172.
71. Peter RU, Richarz-Barthauer U. Successful treatment and prophylaxis of scalp seborrheic dermatitis and dandruff with 2% ketoconazole shampoo: results of a multicentre, double-blind, placebo-controlled trial. *Br J Dermatol* 1995; 132(3):441–445.
72. Berger R, Mills O, Jones E. Double-blind, placebo-controlled trial of ketoconazole 2% shampoo in the treatment of moderate to severe dandruff. *Adv Ther* 1990; 7(5):247–256.
73. Go IH, Wientjens DP, Koster M. A double-blind trial of 1% ketoconazole shampoo versus placebo in the treatment of dandruff. *Mycoses* 1992; 35(3–4):103–105.
74. Arrese J, Piérard-Franchimont C, De Doncker P, et al. Effect of ketoconazole-medicated shampoos on squamometry and *Malassezia ovalis* load in pityriasis capitis. *Cutis* 1996; 58(3):235–237.
75. Pierard-Franchimont C, Piérard GE, Arrese JE, et al. Effect of ketoconazole 1% and 2% shampoos on severe dandruff and seborrheic dermatitis: clinical, squamometric and mycological assessments. *Dermatology* 2001; 202(2):171–176.
76. Squire RA, Goode K. A randomised, single-blind, single-centre clinical trial to evaluate comparative clinical efficacy of shampoos containing ciclopirox olamine (1.5%) and salicylic acid (3%), or ketoconazole (2%, Nizoral) for the treatment of dandruff/seborrheic dermatitis. *J Dermatol Treat* 2002; 13(2):51–60.
77. Draeos Z. Shampoo, hair, and technology: part two. *Cosmet Dermatol* 2003; 16(2):71–76.
78. Nakagawa H, Etoh T, Yokota Y, et al. Tacrolimus has antifungal activities against *Malassezia furfur* isolated from healthy adults and patients with atopic dermatitis. *Clin Drug Invest* 1996; 12:245–250.
79. Ling MR. Topical tacrolimus and pimecrolimus: future directions. *Semin Cutan Med Surg* 2001; 20(4):268–274.
80. Faergemann J. Seborrheic dermatitis (dandruff). In: Peter Elsner HIM, ed. *Cosmeceuticals: Drugs vs. Cosmetics*. New York, NY: Marcel Dekker, Inc., 2000:197–202.
81. Caputo R, Barbareschi M. Itraconazole: new horizons. *G Ital Dermatol Venereol* 2002; 137:1–7.
82. Sheth RA. A comparison of miconazole nitrate and selenium disulfide as anti-dandruff agents. *Int J Dermatol* 1983; 22(2):123–125.
83. Zecevic R, Toskic-Radojicic M, Mijailovic B. [Therapy of dysseboreic dermatitis with ketoconazole]. *Vojnosanit Pregl* 1993; 50(1):61–63.

84. Bartalini P, Bilenchi R, Dina F. Anti-pityriasis of a line of products containing piroctone olamine. *G Ital Dermatol Venerol* 1987; 122(3):XI-XIX.
85. Gleser L, Olkin I. Stochastically dependent effect sizes. In: Cooper H, Hedges LV, eds. *The Handbook of Research Synthesis*. New York: Russell Sage Foundation Publications, 1994:339-355.
86. Wang M, Bushman BJ. *Integrating Results through Meta-Analytic Review Using SAS Software*. Cary, NC: SAS Publishing, 1999.
87. Wigger-Alberti W, Kluge K, Elsner P. [Clinical effectiveness and tolerance of climbazole containing dandruff shampoo in patients with seborrheic scalp eczema]. *Schweiz Rundsch Med Prax* 2001; 90(33):1346-1349.
88. Pierard-Franchimont C, Piérard GE, Vroome V, et al. Comparative anti-dandruff efficacy between a tar and a non-tar shampoo. *Dermatology* 2000; 200(2):181-184.
89. Schwartz J. [Letter to the Editor]. *Eur J Dermatol* 2002; 12:617.
90. Leyden JJ, McGinley KJ, Mills OH, et al. Effects of sulfur and salicylic acid in a shampoo base in the treatment of dandruff: a double-blind study using corneocyte counts and clinical grading. *Cutis* 1987; 39(6):557-561.
91. Sugita T, Suto H, Unno T, et al. Molecular analysis of malassezia microflora on the skin of atopic dermatitis patients and healthy subjects. *J Clin Microbiol* 2001; 39(10):3486-3490.



## The periorbital wrinkle

Martin R. Green

### INTRODUCTION

Wrinkles are the most obvious and perhaps the most disliked aspect of facial ageing. Considering this, it is surprising that relatively little is known about the biological changes that cause a wrinkle, what is its physical structure and why is it so hard to erase a wrinkle once it is formed.

Many people, scientists and laymen alike, have considered wrinkles to be cosmetic and so not worthy of research. There was a common belief that as the skin aged, collagen stiffened, elastic networks collapsed and the mechanical properties of the skin degraded. Wrinkles were just seen as the “points of weakness” where the degraded skin creased.

Nothing has served to make a larger impact on this simplistic model than the success of botulinum toxin in reducing facial wrinkles. Botulinum toxin is injected into the muscles underneath the skin and causes a long lasting paralysis and relaxation of those muscles. The fact that this has such a dramatic effect on the appearance of the wrinkle demonstrates that deep wrinkles are not simply a phenomenon of changed properties of the skin but rather are an effect of the entire integumentary system including not only the dermis but also the subcutaneous fat and muscle layers.

More recently “perceived age,” the average estimated age of a person by independent assessors, has gained credence as a highly useful biomarker of ageing and a method by which to study the facial attributes of attractiveness (1,2). Perceived age has been shown to be a robust indicator of health (1) and to be influenced by facial wrinkles (2). In a 70+ age group perceived age predicted human survival and correlated inversely with physical and cognitive functioning (1). As well as facial wrinkles, hair graying and lip height are also major contributors to perceived age. Twin studies have also recently shown that facial wrinkles are more or less equally influenced by genetic and environmental factors while hair graying and lip height are largely influenced by genetic factors (2).

This book chapter briefly reviews what is known about the wrinkle and sets out studies that cast new light on how deep periorbital wrinkles (“crow’s feet”) form and are maintained, pointing to new therapeutic approaches to treat periorbital wrinkles.

### WRINKLES AS AN ASPECT OF AGED SKIN

There is a considerable literature describing the differences between youthful and aged skin. In many cases, no attempt is made to differentiate between the area of the wrinkle and the unwrinkled skin around it. In large part this is because it is sometimes difficult to locate a wrinkle in a histological section.

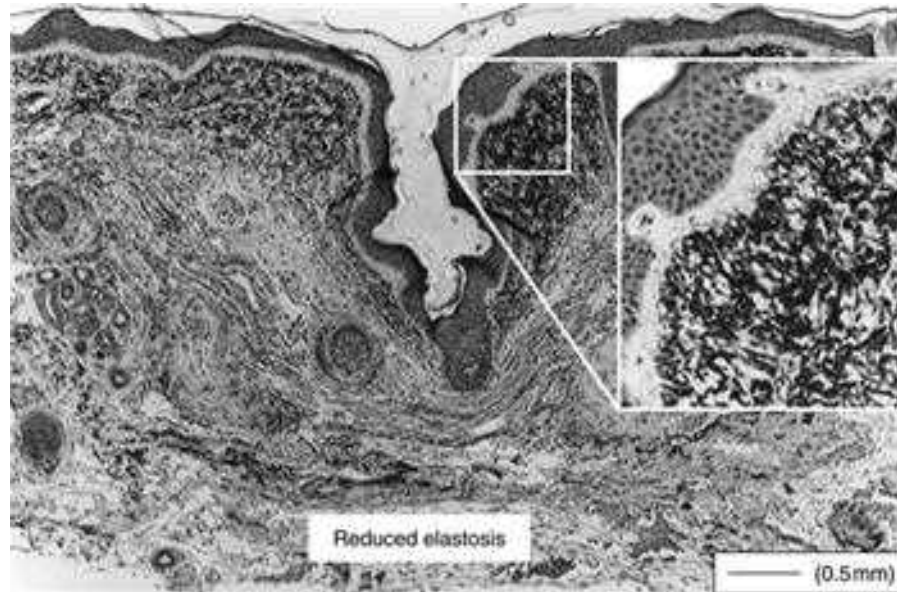
For a review of the wrinkle literature the reader is guided to the articles by Kligman (3), Contet-Audonneau (4), Lavker (5), and Tsuji (6). The key findings are as follows:

1. The epidermis thins with age and the properties of the stratum corneum change in a multitude of ways including reduced barrier repair properties and decreased elasticity. These changes are particularly important in causing “fine lines” and are the changes that are countered by the vast majority of effective topical moisturizing products.
2. The intricate, interconnected, elastic fiber network in the dermis degrades and is replaced (especially in the case of sun-exposed skin) by large deposits of poorly organized elastin deep in the dermis. This leads directly to loss of resiliency—the ability of the skin to quickly return to its original shape after distortion. In extreme cases the large elastin deposits (so-called elastosis) can cause the skin to look sallow and yellowish in color.
3. Collagen fibers become less well organized and the collagen itself undergoes chemical changes that reduce its mechanical flexibility. Repeated imperfect collagen repair can lead to “scar-like” patches of stiff, aligned collagen.
4. Glycosaminoglycan composition changes. In sun-exposed skin with chronic (i.e., years) of photodamage there is a marked increase in types of sulphated glycosaminoglycans (versican) at the expense of others (decorin). Since these molecules can hold as much as 1000 times their own weight of water in an elastic gel these changes hugely affect the water content of the dermis.
5. The subcutaneous fat layer, especially in women, decreases markedly in thickness.

It is self evident that skin which has undergone all these deleterious changes is more prone to wrinkles. However, these changes are not sufficient to cause some types of wrinkling to occur. It is quite possible to find individuals and areas of skin where all these histological and biochemical changes can be seen but no wrinkles are visible. The extra factor that seems to be necessary is repeated movement of the skin causing folding of the skin. Over time, and combined with the overall ageing changes set out above, wrinkles form and progressively get worse. Thus wrinkling can be seen on the face where “expression lines” form but not in other sun-exposed areas even though the histological degradation of the skin may be worse. Cigarette smoking also makes a marked, adverse contribution to wrinkling (7) particularly around the mouth.

### LOCAL DIFFERENCES IN THE WRINKLE COMPARED WITH SURROUNDING SKIN

Considering what an obvious feature a wrinkle represents, there is a surprising paucity of published data contrasting the



**Figure 30.1** Elastic fibers in the periorbital wrinkle (orcein stain).

wrinkle with the surrounding skin. Such studies that have been done suggest that the classic features of solar elastosis are less in the base of the wrinkle than in the surrounding skin (4,6).

One reason for the limited number of studies is that it is very difficult to identify wrinkles—even deep ones—in histological sections. When the skin is excised, the wrinkle opens and partially disappears—evidence that the wrinkle is an aspect of the whole skin. To overcome this problem a novel technique was used whereby a line of cyanoacrylate glue, visible in Figure 30.1, was introduced into the wrinkle and allowed to set prior to taking a biopsy of the wrinkle. With this precaution, the shape of the wrinkle was preserved through processing allowing a better correlation of histological changes to the architecture of the wrinkle.

Sections of these biopsies, which were taken from the periorbital crow's feet area were stained by a variety of techniques using both conventional and immunostaining techniques. We confirmed the finding (4,6) that the elastic fiber network was far less damaged at the base of a deep wrinkle than on the sides of the wrinkle or adjacent skin (Fig. 30.1). This is thought to be a consequence of the base of the wrinkle being less exposed to ultraviolet light during and after formation, than the surrounding skin. It suggests that the damage to the elastic fiber network is unlikely to be a primary cause of the wrinkle.

In contrast to the normal-appearing elastin at the wrinkle base the "elastin" at the sides of the wrinkle is heavily disorganized (elastotic), a phenomenon that is worse on the lower, more sun exposed side, viewed as the wrinkle would be positioned when in situ on the face. The collagen fibers orientations were also quite abnormal. In stark contrast to the sides of the wrinkles, where the collagen fibers tended to run parallel to the long edge of the wrinkle and were in places relatively normal, at the wrinkle base there was a dense band of highly aligned collagen fibers running perpendicular to and underneath the wrinkle (Fig. 30.2, also clearly visible in Fig. 30.1).

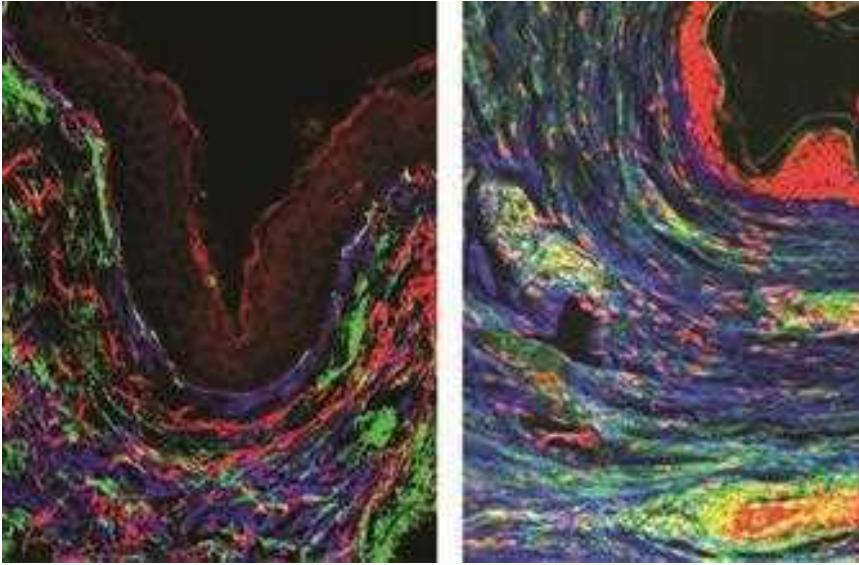
This band of highly aligned collagen was one of the few features of the permanent periorbital wrinkle that correlated clearly with the wrinkle location and gave any clue to what dictated the shape of the wrinkle. However, predicting how a complex material like skin will behave under different flexing force regimes is a difficult challenge and intuitively "obvious" phenomena often turn out to be very different from what intuition would suggest.

To investigate this, a computer model of the skin was developed (M. Eastwood and M.R. Green, unpublished data) incorporating the structural information derived from the histology, and building in physical material constants for the different parts of the skin. Other simulated models for immediate wrinkle formation after skin compression have been prepared (8,9) but these do not take account of the effect of changing tension on the long term biological responses of the skin, and local changes in wrinkle architecture. A novel method using digital image speckle correlation has also been developed to study the mechanical properties of skin, showing that lines of increased tension in skin coincide with the position of prominent wrinkles (10).

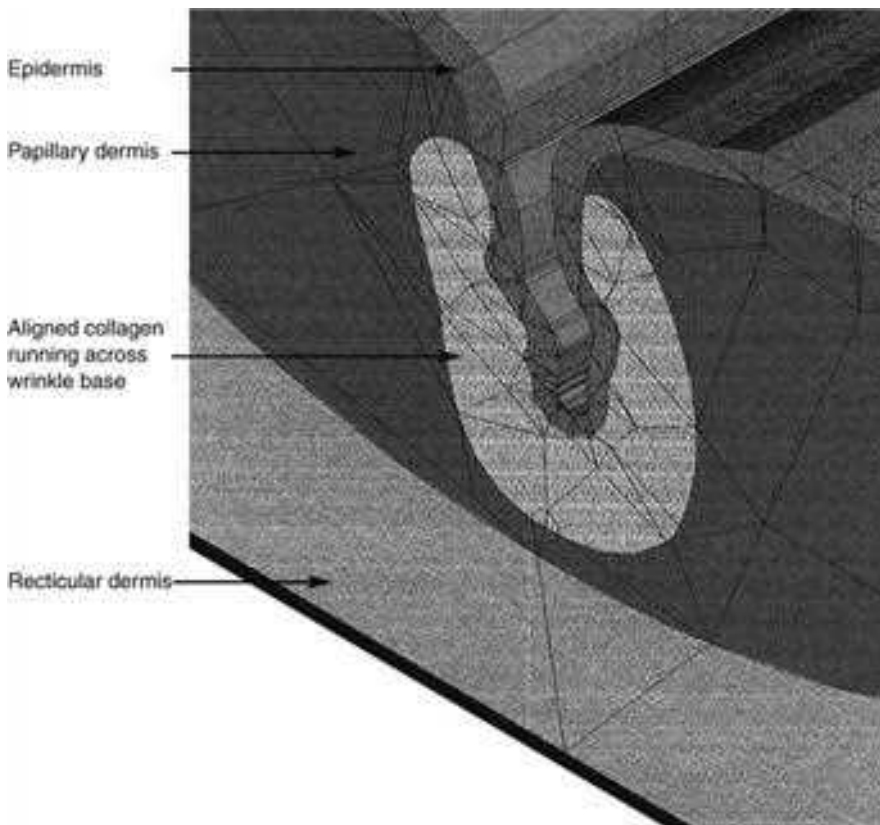
### COMPUTER MODEL OF THE PERIORBITAL WRINKLE

Figure 30.3 shows the basic structure of the computer model. It incorporates four different layers: the epidermis, the papillary dermis, the reticular dermis and the highly aligned zone of collagen. Material properties of these zones were estimated from literature values, as shown in Table 30.1. The model was based on finite element analysis using ProMechanica<sup>®</sup> software. The base of the skin in the model was anchored to an inflexible substrate. No attempt was made to simulate the effects of muscle or the attached subcutaneous fat layer.

The first and critical finding in preparation of the model was that the simulated wrinkle could only maintain its shape



**Figure 30.2** Highly aligned collagen at the base of the wrinkle. Red, tropoelastin; green, fibroblasts; blue, mature collagen (*left*). Red, nuclei; green, fibroblasts; blue, mature collagen (*right*). *Source:* Courtesy of J. Wares.



**Figure 30.3** Visualization of the wrinkle computer model. *Source:* Courtesy of M. Eastwood.

with compressive forces pushing the wrinkle closed. Three possible sources of this compressive force exist.

1. Overall pressure from the surrounding skin. If older skin has a larger natural area than it is constrained to by its attachment to the underlying tissue, then the whole area of

skin will be under compression. This is probably a significant factor where there has been significant loss of the subcutaneous fat layer leading to shrinkage of the attachment area for the skin. Conventional “face-lift” procedures act on this compression effect by reducing the natural area

**Table 30.1** Physical Constants Used in the Wrinkle Model

	Epidermis	Papillary dermis	Reticular dermis	Aligned collagen
Young's modulus (MPa)	0.06	0.05	0.048	0.065
Poisson's ratio	0.45	0.49	0.49	0.49

of the skin so that wrinkle compression is replaced by a tension. Skin is usually maintained under tension as is evident from its behavior when cut (it will gape) or from instrumental measurements (11–13).

2. Action of subcutaneous muscles. The skin is extensively attached to muscle groups that can actively create tensions in the skin. This is particularly so on areas such as the forehead and around the mouth. Where muscle groups act to compress areas of skin, the compression can generate and sustain wrinkles. Botulinum toxin injections act on these muscle groups causing them to relax for as long as six months. The fact that in certain types of wrinkle such injections virtually eliminate the visible wrinkle suggests that for these wrinkles the muscle generated compressive forces are the primary cause.
3. Tension carried within the aligned collagen at the wrinkle base. Figure 30.4 shows the computer wrinkle model when the wrinkle has been allowed to open up, as if it were excised. The color scale shows the amount of stress in the different elements of the model. A major stress is found in a narrow zone at the base of the wrinkle, in the aligned collagen domain. This stress arises because of the removal of the compressive force on the wrinkle sides, and gives an indication of what might happen during day to day flexing of the wrinkle on the face. Put simply, the aligned collagen band is stiff but under little stress when the wrinkle is closed. As the wrinkle opens, the stiff collagen band deforms and resists the opening of the wrinkle. This

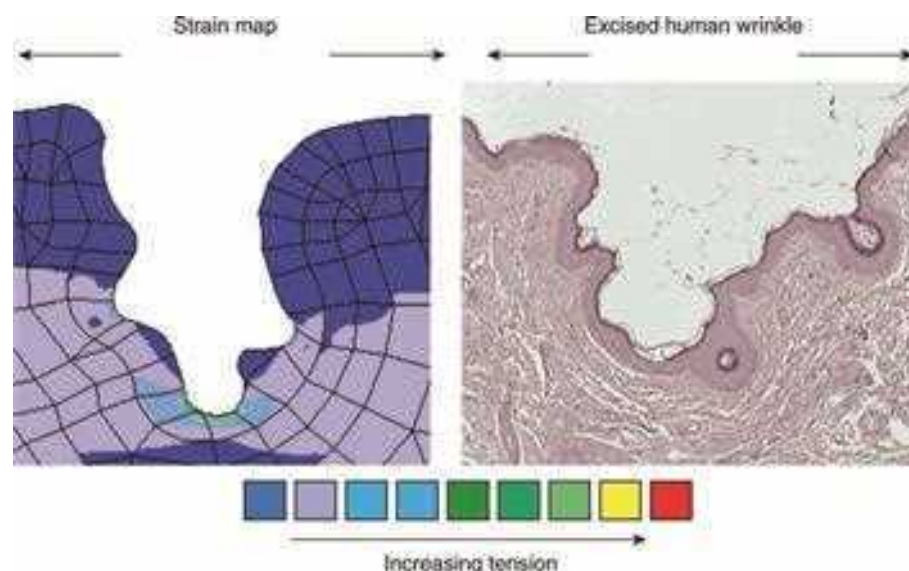
strongly implies that the aligned collagen band is a major factor in maintaining the shape of the periorbital wrinkle.

### ORIGIN OF THE ALIGNED COLLAGEN LAYER

Why does the wrinkle possess this deep zone of highly aligned scar-like collagen? While it is clearly important to the maintenance of the wrinkle once formed, it is unlikely to have a role in the initial formation of the wrinkle. Indeed if such a zone were present in an area of unwrinkled skin it would probably cause the wrinkle to form elsewhere rather than in the rigid zone. To understand how the zone could form it is necessary to consider the interplay of forces within the tissue and the biological behavior of fibroblasts within the tissue.

Fibroblasts are richly endowed with surface molecules that will bind to components of the connective tissue—collagen, fibronectin, etc. When these surface molecules bind to the connective tissue matrix, they transduce mechanical forces acting through the binding sites into biological changes in the cell. One outcome of this is that fibroblasts within a connective tissue matrix that is under tension increase their synthesis of collagen and deposit it preferentially in the direction of the tension (14–16).

What does this mean for the skin? In unwrinkled skin under tension, individual collagen fibers have a random direction of alignment. When unwrinkled skin is flexed so as to form a temporary “expression” fold, the greatest tension is experienced by the tissue at the base of the fold. In response to that



**Figure 30.4** Strains calculated in the computer wrinkle model of a “relaxed” wrinkle (*left*) compared with the histology of an excised, relaxed human periorbital wrinkle where the cyanoacrylate glue failed to hold the wrinkle sides together (*right*).

tension fibroblasts deposit collagen in the direction of the tension, perpendicular to the fold. The next time the skin is flexed and the fold forms, the tissue at the base of the fold is just a little stiffer because of the deposited collagen. That makes the tension at the wrinkle base just a little higher and induces the deposition of still more aligned collagen. Over time this vicious circle continues until the aligned collagen comes to dominate the stress field in the skin to the point where it maintains a permanent wrinkle. Sunlight, particularly UVB radiation, exaggerates this effect by activation of proteases and the triggering of further collagen realignment (17) and loss of elastic fibers (18).

### IMPLICATIONS FOR TREATMENT OF WRINKLES

It is clear from the discussion above that there are multiple distinct factors such as acute and chronic sun exposure, natural skin tension and flexing, intrinsic ageing changes including the thinning of the dermis and loss of subcutaneous fat, causing and sustaining wrinkles. In all body and facial sites it is likely that all the factors contribute to the overall wrinkling effect, but the relative contribution of the different factors will differ, giving rise to different wrinkle structures, suggesting a different optimum treatment regimen.

On the forehead, the dominant factor sustaining wrinkles appears to be the action of the subcutaneous muscles. Botulinum toxin injections are therefore effective.

On the cheeks and around parts of the mouth, loss of subcutaneous fat and elastic fibers leads to a general loss of tension of the skin. In these cases, botulinum toxin is less effective and surgical removal of flaps of skin or generalized contraction of the skin using laser treatment is necessary to have a substantial effect.

The crows feet area is characterized by wrinkles maintained by the stiffened aligned collagen zone at the wrinkle base. Botulinum toxin has relatively little effect on these wrinkles and while surgical face-lift procedures may have temporary benefits, the analysis above suggests that stretching the wrinkles out may well cause yet more deposition of aligned collagen at the wrinkle base, ensuring that the wrinkles will return and possibly making the problem worse in the long term.

The analysis above suggests that a promising route for treatment of such periorbital wrinkles would involve stimulation of deep dermal collagen remodeling, to put into reverse the vicious cycle that caused the aligned collagen zone to form. If collagen turnover could be stimulated while the skin was exposed to tension parallel to the long edge of the wrinkle, then the existing perpendicular collagen fibers would be reduced and remodelled while new fibers forming parallel to the wrinkle would no longer sustain the wrinkle shape. Retinoic acid might be effective used in this way, as it has been shown both to increase collagenase expression in skin and to increase the deposition of newly synthesized collagen. To our knowledge, such a combined topical tension and topical treatment experiment has yet to be attempted.

### ACKNOWLEDGMENTS

I thank Dr I.R. Scott for coauthoring the first edition of this book-chapter and W.E. Parish (Unilever Research, Colworth Laboratory, Bedford, U.K.), M. Eastwood (University of Westminster,

London, U.K.), M. Simon (Departments of Oral Biology and Dermatology, State University of New York, Stony Brook, New York, U.S.A.), and D.M. Siegel (Departments of Oral Biology and Dermatology, SUNY, Stony Brook, New York, U.S.A.) for access to results prior to publication.

### REFERENCES

1. Christensen K, Thinggaard M, McGue M, et al. Perceived age is a clinically useful biomarker if ageing: cohort study. *Br Med J* 2009; Dec, in Press.
2. Gunn DA, Rexbye H, Griffiths CEM, et al. Why some women look young for their age. *PLOS One* 2009; Nov, in Press.
3. Kligman AM. The classification and treatment of wrinkles. In: Kligman AM, Takase Y, eds. *Cutaneous Ageing*. Tokyo, Japan: University of Tokyo Press, 1989:547-555.
4. Contet-Audonneau JL, Jeanmarie C, Pauly G. A histological study of human wrinkle structures: comparison between sun-exposed areas of the face, with or without wrinkles, and sun-protected areas. *Br J Dermatol* 1999; 140:1038-1047.
5. Lavker RM. Structural alterations in exposed and unexposed aged skin. *J Invest Dermatol* 1979; 73:59-66.
6. Tsuji T, Yorifuji T, Hayashi Y, et al. Light and scanning electron microscopic studies on wrinkles in aged persons' skin. *Br J Dermatol* 1986; 114:329-335.
7. Morita A. Tobacco smoke causes premature skin ageing. *J Dermatol Sci* 2007; 48:169-175.
8. Kuwazuru O, Saothong J, Yoshikawa N. Mechanical approach to aging and wrinkling of human facial skin based on the multistage buckling theory. *Med Eng Phys* 2007; 30:516-522.
9. Flynn CO, McCormack BAO. A three-layer model of skin and its application in simulating wrinkling. *Comput Methods Biomech Biomed Engin* 2009; 12:125-134.
10. Staloff IA, Guan E, Katz S, et al. An in vivo study of the mechanical properties of facial skin and influence of aging using digital image speckle correlation. *Skin Res Technol* 2008; 14:127-134.
11. Gibson T, Kenedi RM. The significance and measurement of skin tension in man. In: *Transactions of the Third International Congress on Plastic Surgery*. Baltimore: Williams & Wilkins, 1963:387-395.
12. Alexander A, Cook TH. Accounting for natural tension in the mechanical testing of human skin. *J Invest Dermatol* 1977; 69: 310-314.
13. Diridollou S, Vabre V, Berson M, et al. Skin ageing: changes of physical properties of human skin in vivo. *Int J Cosmet Sci* 2001; 23:353-362.
14. Eastwood M, Mudera VC, McGrouther DA, et al. Effect of precise mechanical loading on fibroblast populated collagen lattices: morphological changes. *Cell Motility Cytoskeleton* 1998; 40:13-21.
15. Wang JHC, Grood ES. The strain magnitude and contact guidance determine orientation response of fibroblasts to cyclic substrate strains. *Connect Tiss Res* 2000; 41:29-36.
16. Lindahl GE, Chambers RC, Papakrivopoulou J, et al. Activation of fibroblast procollagen 1(1) transcription by mechanical strain is transforming growth factor  $\beta$  dependent and involves increased binding of CCAAT-binding factor (CBF/NF-Y) at the proximal promoter. *J Biol Chem* 2002; 277:6153-6161.
17. Takema Y, Nishijima A, Ohsu H, et al. Skin morphology at the time of UV irradiation is important for wrinkle formation. *J Soc Cosmet Chem* 1997; 48:297-306.
18. Lee JY, Kim YK, Seo JY, et al. Loss of elastic fibers causes skin wrinkles in sun damaged skin. *J Dermatol Sci* 2008; 50:99-107.

## Cosmetology for normal nails

Robert Baran and Douglas Schoon

### INTRODUCTION

Evolving from the primeval claw, the nail's working uses became less important, while over time their aesthetic value has grown more important. The application of cosmetics to the nail can be done to enhance length, beautify, or address specific needs. The nail is a convex, hard, horny plate covering the dorsal aspect of the tips of the fingers and toes (Fig. 31.1). Its appearance is determined by the integrity of the terminal bony phalanx and the perionychium, that is, matrix, nail bed and hyponychium, and nail folds. The nail plate, produced by the matrix, grows from a pocket-like invagination of the epidermis, and adheres firmly to the nail bed. Tissue from the under surface of the proximal nail fold also tightly adheres to the surface of the nail and, as the nail grows, emerges from underneath the eponychium to create the cuticle. This cuticle tissue creates a resistant gasket-like seal that helps protect the nail pocket from infection, irritants, etc. The most distal part of the matrix, the whitish semicircular lunula is visible wherever it extends beyond the proximal nail fold. Juxtaposed to the lunula, the pink nail bed epithelium is made from parallel longitudinal rete ridges and subepithelial capillaries running longitudinally at different levels. Adjacent to the nail bed, the hyponychium, an extension of the epidermis under the nail plate, marks the point at which the nail separates from the underlying bed tissue. There is small area between the nail and the distal bony phalanx that is occupied by nonkeratinizing nail epithelium, as well as highly vascular mesenchyme containing glomus organs.

The following should be borne in mind:

1. The proximal matrix forms the surface of the nail plate and the distal matrix forms its inferior part. It is, therefore, possible to locate initiating pathology by a thorough examination of the nail.
2. Finger nails grow at a rate of 0.1 mm a day; toenails grow much more slowly. It can take 12 to 18 months to replace a large toenail, as opposed to 5 to 6 months for the fingernail. The nail's functional role is to protect the nail bed and help prevent breakage or fracture of the bony tips at the end of each finger and toe. The underside provides counter pressure on the pulp, essential for good tactile sensations involving the fingers. Nail beauty depends on several main factors: the shape and length of the nail, its color (or decoration), and its texture.

### CARE AND ADORNMENT OF THE NORMAL NAIL The Shape of the Nail

The shape of the nail depends on proportion and contour. The ratio of length to breadth of the nail is critical to its aesthetic appeal, and the two dimensions should be approximately equal

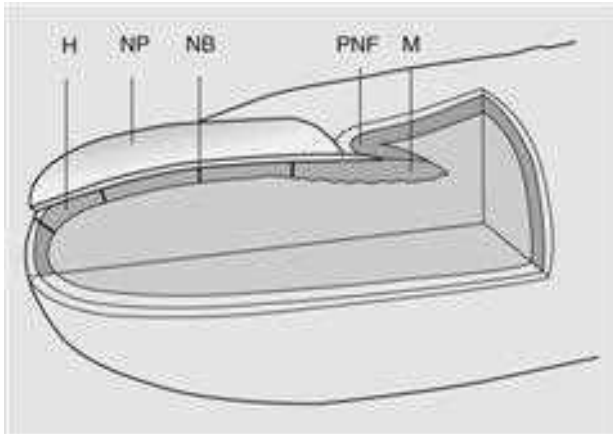
(1), at least on the thumb. When the "magic" ratio differs from the ideal, the nail is less attractive (Fig. 31.2).

Until the early 90s, oval-shaped nails were most common, but the current trend is to cut the tip more or less squarely at the free edge (Fig. 31.3) to create an illusion of thinner, more tapered, and graceful fingers. When too long, however, nails may not only become unsightly but also the length may interfere with hand performance and increase the risk of injury. A long nail is more likely to become caught and, acting like a lever, can lead to catastrophic separation of the nail plate–nail bed attachment, a condition called onycholysis. The form or style of the nail can vary geographically. In some locales, shorter nail lengths are preferred nails, usually with rounded or almond-shaped free edges that can create a very natural-looking nail, if skillfully applied, while in other areas the preference is for longer nails with higher apex arches. Artificial nails are often used to seal the surface of the nail to help prevent mild peeling or splitting at the free edge as well as to enhance their look for cosmetic purposes, that is, reshaping flat nails with more attractive natural looking arches or creating more dramatic curvature at the free edge. They can also be used to correct the coloration of the nail or underlying tissue bed or to create the illusion of a longer nail bed. It is a misperception that they are mostly worn to lengthen the nail plate.

### THE DECORATION OF THE NAIL

For nails of equal length and corresponding contour, a colored or painted nail is usually considered more attractive (Fig. 31.4). Interest continues to grow for many types of sculptured artificial nails, and the current trend is to decorate them with everything from a painted snowflake to a three-dimensional flower or flag to a portrait of their grandchild. Colorant powders or colored UV gels or glitters are used to create artificial nail with permanent designs that can be very intricate and beautiful. In some places, this is considered a new art form, highly sought after and collected by nail art enthusiasts. Diamonds or emeralds have even been fixed into the elongated nails, while some wear intricate jewellery attachments to the free edge (Fig. 31.5). Like jeweller, some practitioners utilize preformed nails of gold or goldplate, some studded with jewels.

Modern nail art was invented in the late 1960s when American teens began to paint colorful designs on their nails. The fad evolved during the 1970s when Japanese nail technicians began mixing colored pigments into their artificial nail enhancement products. Airbrushing with paint became popular for creating artistic designs on the nails, and this service is still performed in salons to a lesser degree. The newest technique is to use decorated films (coated on one side with a heat-sensitive adhesive backing) to decorate either natural or



**Figure 31.1** Anatomy of the nail apparatus. *Abbreviations:* M, matrix; NB, nail bed; H, hyponychium; NP, nail plate; PNF, proximal nail fold. *Source:* After Dr E Haneke.



**Figure 31.2** The racket nail of the middle finger is less attractive than the nail exhibiting the ideal ratio.



**Figure 31.3** There is a tendency to cut the tips of the nails more squarely.



**Figure 31.4** Painted nails are more attractive than plain nails.

artificial nails. There are hundreds of colors available for UV gels and acrylic nail powders users and many hundreds of preprinted designs and decorations available on adhesive backed film (Fig. 31.6).

### THE TEXTURE OF THE NAIL

The appearance and condition of the nail can determine its esthetic appeal. The nail may be exposed to external agents or conditions that may render it softer or brittle or peeling. The brittle nail is vulnerable to single or multiple longitudinal splitting and horizontal splitting into layers (onychoschizia) (Fig. 31.7) or less often to transverse breaking (Fig. 31.8).

Frail nails can benefit from external treatments with oils or waxes that may absorb to soften or may seal the surface of the nail to prevent excessive moisture loss or absorption. Such treatments are popular and may provide value, especially when used in conjunction with avoidance of "wet work." In addition, the age-dependent decrease in cholesterol sulfate levels might explain the previously observed higher incidence of brittle nails in women (2).

### ITEMS FOR NAIL CARE

The following are examples of tools used for nail care (3).

#### Nippers and Cutters

Nippers are used to chip away loose artificial nail place over the lunula area in preparation for reapplication in the area where the nail has grown out or where product is losing adhesion. This process is called "a fill" or "rebalance." These tools are often used to nip off tags of dead skin in these areas surrounding the nail. Some are especially designed for toenails. Cutters are jaw-like blades operated by a spring mechanism and used to sever the free edge of the nail or artificial tips. They are available in many sizes.

#### Emery Board

A flat, disposable, "paperboard" wand, coated with abrasives emery powder and used to shape, reduces the length or smooth sharp or jagged edges on the nail's free edge. These types of



**Figure 31.5** Intricate jewelry attached to the free top extremity of the nail.



**Figure 31.6** Nail art.



**Figure 31.7** Onychoschizia (splitting into layers).





**Figure 31.8** Complete transverse breaking.

abrasive files are inexpensive and often used by nail salon's offering low-cost services and are considered single-use disposable items.

### Other Abrasive Nail Files

Other types of abrasive nail files are made by coating an elongated board made of metal, glass, fiberglass, hard plastic, or wood with abrasives particles ranging in sizes and hardness. The "grit" of abrasive nail files is a measure by counting the number of abrasive particles per cubic centimeter. Low-grit boards (60–120 grit) are used to quickly removing layers of the artificial nail and should not be used directly on a natural nail. Medium-grit boards (120–240) are for smoothing and shaping both artificial and natural finger- and toenails. High-grit boards (800–2400) are used for buffing, polishing, and finishing. Grit is not the only determining factor. Nail files can be coated with either crystalline aluminum oxide or silicon carbide. Silicon carbide is 20% harder than aluminum oxide, making these materials significantly more aggressive. Fine particles of diamond dusts are electroplated on to a metalized fiberglass board, giving these abrasive files great durability and longevity. Diamond's high cost and extreme hardness (50% higher than silicon carbide) is the reason that these files have limited value for this application.

### Blocks

These are also abrasive nail files, and they take the form of a larger, rectangular foam block that fits comfortably into the

hand. Blocks are the most widely used primarily because of their improved comfort, ease of use, and efficiency.

### Nail Buffer

Specialty nail files are designed to create very smooth and high shine surfaces on natural or artificial nails. They are normally used as "three-way buffer," having three different grit sizes used in succession from coarse to finest particle size, which remove scratches and create smooth, uniform surfaces.

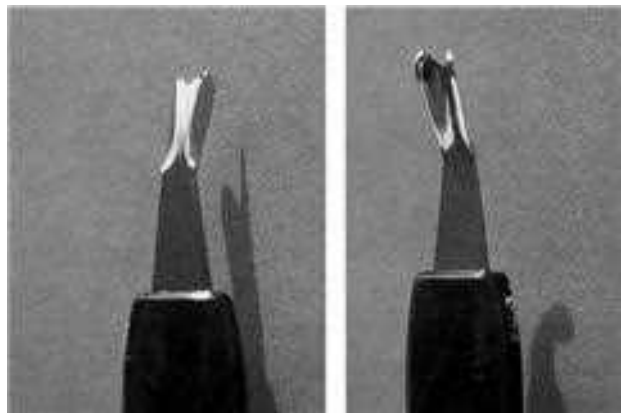
Padded chamois buffers used in conjunction with mild pumice-type abrasive creams or waxes and oils will produce a very high shine on the nail surface. Such systems have been used for generations. This is not a widely used mainstream technique, but instead considered a more traditional technique used by more traditional practitioners.

### Pushers

These devices are used to gently push back the eponychium and expose more of the lunula. They can also be used to carefully loosen, scrape, and remove cuticle tissue from the nail plate. Pushers can be polished, metallic probes with variously shaped rounded ends and relatively dull edges to minimize the potential for soft tissue injury. Another type is a pencil-shaped plastic or wooden implement used in the same fashion. The advantage of using wood is safety, since they are less likely to cause injury to the nail folds. Originally fabricated from orange wood, now they are primarily birch and are considered a single-use disposable item.

### Cuticle Trimmer

The small, clipper-jawed scissors are used inappropriately for cutting frayed skin and living tissue (Fig. 31.9). Devices that are curette-like, using a V-shaped blade mounted to a plastic handle, are used to shave living tissue. Nail technicians are using them for cutting the nail fold, which they mistakenly believe it is the cuticle. Trimming this living skin creates hardened tissue. When nail technicians cut this tissue a way with any device, they often breach the skin barrier, this increases potential for infection; this is why government regulations usually forbid service providers, such as nail technicians, from intentionally cutting living skin as part of their professional services. Like all



**Figure 31.9** Cuticle trimmer.

devices designed to shave the skin, they should not be used to perform salon services.

### Nail Whitener

This is a pencil-like device with a white clay (kaolin) core used to deposit color on the under surface of the free edge of the nail. These should be avoided in professional salon settings since reuse can contribute to transmission of pathogenic organisms from client to client.

### Disinfectant Container and Cover

A disinfection container should have a cover and be large enough to contain enough disinfectant solution to completely cover all items intended for disinfection. Many have a tray for removing implements and helping to prevent skin contact with potentially irritating, disinfectant solutions or provide tongs for reaching into the solution to withdraw implements.

### Pedicures

Pedicures require specialized implement. Toenails are larger and thicker, and hardened callus can be tough to handle without the proper tools. Heavy-duty toenail cutter with a squeeze-grip action are used along with abrasive files to smooth and shape toenails. Abrasive grit foot buffers are used on calluses. Recently, California prohibited the use of metallic razors or abrasives on calluses in nail salons. The concern was that such tools were too aggressive and dangerous for use in nail salons.

Aggressive tools and procedures, that is, use of highly acidic or alkaline callus, that completely remove the callus are more concentrated and therefore have a higher potential to injure the underlying tissue. A risky practice performed by some nail technicians is to use razor-type devices to cut calluses from the foot. Complete removal of the callus is considered medical procedure and is not appropriate for salon services and should be discouraged. Salon services should only smooth callous, and not remove them.

## TOILETRIES AND COSMETICS

Evaporative coatings, including base coats, top coats, and nail varnish.

### Nail Varnish Formulation

Whether they are called nail varnish, enamel, lacquer, varnish, or color, these products are identical in function and, for practical purposes, nearly the same in basic composition. These different terms are merely marketing terms used to establish brand identity. The varnish may be clear, opaque, or shaded with color. Varnishes may appear to be nothing more than a paint-like coating for the nail, but the chemistry is much more complex. In its simplest form, a nail varnish is defined as a durable film coating created by evaporation of a volatile solvent component. However, the coating must withstand severe abuse without losing color, gloss, or adhesion. Luckily, a clever formulator has a wide range of raw materials from which to choose, and through proper ingredient selection these properties can be greatly enhanced. However, the cosmetic appearance and durability of the final product are not the only considerations when choosing ingredients. Regulatory agencies and consumer perception also play important roles. For these and other reasons, it is instructive to examine each

ingredient type to gain a better understanding of these useful cosmetics.

### Nail Varnish Basics

A typical varnish formulation consists of seven basic types of ingredient:

1. Film formers
2. Film modifiers
3. Plasticizers
4. Solvents/diluents
5. Viscosity modifiers
6. Stabilizers
7. Coloration additives

Each of these contributes to the quality of the final product. If proper ingredient selections are made and correctly balanced, the varnish will be easy to apply and remove, quick-drying, waterproof, glossy, chip- and scratch-resistant, and flexible, and will adhere well to the nail. Ideally a properly applied coating should remain cosmetically attractive and intact for five days to a week. Also, the varnish coating must have a low potential for toxicity and adverse skin reactions.

### Film Formers

The role of the film former is to create a smooth, continuous coating over the nail plate. The coating material of choice is an organic polymer called nitrocellulose (cellulose nitrate), the first natural polymer to be successfully modified by chemical manipulation, was commercially produced in 1860 by treating cellulose with a mixture of nitric and sulfuric acids. Originally used in high explosives, dry powdered nitrocellulose is highly unstable and sensitive to light, heat, atmospheric moisture, and oxygen, as well as an alkaline pH. It is so chemically reactive that it must be transported in a polar organic solvent, usually ethanol or isopropanol, to prevent explosive detonation. Formulators can choose from several viscosities and grades of materials and use them alone or in synergistic blends. Non-nitrated cellulose such as cellulose acetate and derivatives are also used with varying degrees of success. Polyurethanes, polyamides, and polyesters have also been utilized, but cannot match the surface gloss and hardness of nitrocellulose. Also, nitrocellulose blends superbly with colored pigments, producing bright and vibrant colors. Still, disadvantages of nitrocellulose drive formulators constantly to seek alternative materials, since the coatings it produces are brittle, adhere poorly, discolor quickly, and shrink excessively to cause poor adhesion. Examples of other film formers are meth(acrylate) polymers or copolymers.

### Film Modifiers

The purpose of a film modifier is to favorably offset some deficiencies of the primary film former. Specifically, film modifiers are used to improve adhesion. Until recently, the most commonly used modifier is toluenesulfonamide/formaldehyde resin (TSFR) or tosylamide/formaldehyde resin (TF), the name listed in the *International Nomenclature of Cosmetic Ingredients Dictionary* (INCI). Because of the public's erroneous and unfavorable association with formaldehyde gas (see "Formaldehyde Controversy"), this resin has fallen out of favor therefore it is being replaced by other resins, that is, tosylamide/epoxy resin (4), polyvinyl butyral, ester sucrose benzoate, polyesters (5),

acrylic ester oligomers, sucrose acetate isobutyrate (SAIB), and arylsulfonylethanes (6), and various copolymers, that is, adipic acid/fumaric acid/phthalic acid/tricyclodecane dimethanol.

### Plasticizers

Plasticizers keep polymer films flexible and offer a useful way to improve the strength of nitrocellulose films. They reportedly increase separation between the cellulose chains and act as an internal lubricant (7). Film modifiers counterbalance the negative aspects of nitrocellulose, whereas plasticizers alter the properties of the entire film and can have profound, positive effects on flexibility and adhesion. The plasticizer must be compatible and remain in solution without negatively affecting viscosity, consistency, flow, color, or shelf-life. It must not readily escape from the film through migration or volatilization and must be dermatologically innocuous. Camphor (bp 96°C) is the most common example of low molecular weight, high-boiling point plasticizers. Other examples of plasticizers are acetyl tributyl citrate, castor oil, sucrose benzoate, glyceryl tribenzoate, PPG-2 dibenzoate, ethyl tosylamide, glycerol, triacetin, and a polymeric plasticizer called NEPLAST (a polyether-urethane) (8).

Dibutyl phthalate (DBT) was for many years the preferred plasticizer for nail varnish. In 2003, DBT was reviewed in the United States and declared "safe as used" by the Cosmetic Ingredient Review Expert Panel (CIR). However, in that same year, new regulations in the European Union (EU) required that any ingredient listed as category 3 on the EU Dangerous Substance List or CMR List (Carcinogen, Mutagens, and Reproductive Toxicants) must prove to the EU's Scientific Committee on Consumer Products (SCCP) that they are safe before they are allowed for use. DBT was listed as a category 3 (as an additive in spray paint) so rather than undergoing exhaustive and onerous toxicological testing, nail varnish manufacturers around the world began to eliminate this ingredient since they did not wish to carry a separate inventory for the EU.

### Solvents and Diluents

Nail varnish solvents give these products their characteristic odor and flammability, but solvents are vital since they dissolve solid ingredients, and on evaporation, deposit them on the nail plate. The most commonly used are alkyl esters (ethyl, amyl and *n*-butyl acetate) and glycol ethers (propylene glycol monomethyl ether). Since each solvent has a different boiling point and evaporation rate, a skillful formulator can balance several solvents to achieve the desired drying time. Good solvents are those that easily dissolve solid ingredients and reduce viscosity or improve brushability.

Even though they are not solvents for nitrocellulose, ethanol, isopropanol, and butanol act as coupling agents and through hydrogen bonding act synergistically to increase the overall solubility and flow of the system. Diluents are usually nonpolar compounds that are also nonsolvents for nitrocellulose, but help to regulate evaporation rates and stabilize viscosity to prevent uneven evaporation that may affect surface gloss, color, and clarity, especially in humid conditions. A great advantage of diluents is that they may be added in controlled amounts without reducing viscosity.

In the past, toluene was used without significant problems since the 30s as a nail varnish diluents and often accounted for up to 25% of the formulation. Toluene was

added to the list of chemicals for which California's Proposition 65 requires a warning label since it is suspected of causing birth defects and cancer (9,10). However, study by the Nail Manufacturers Council (NMC) performed under the auspices of the California State Attorney General indicates that nail technicians' salon exposure levels are approximately 1000 times below U.S. Federal safe limit set by the Occupational Safety and Health Administration (OSHA) (11). Even so, in 2008 the California Air Resources Board (CARB) identified toluene as an air contaminant that contributes ground level formation of ozone; therefore, most manufacturers have voluntarily discontinued use of the solvent, replacing toluene generally by increasing the levels of ethyl and butyl acetate (12).

### Viscosity Modifiers

Ideally, a nail varnish should have a gel-like consistency to keep pigments suspended, but thinner, more brushable liquids produce better and more uniform films. Luckily, both consistencies are possible in systems that display thixotropic behavior. Thixotropic systems become thinner as they are mixed and brushed, but while at rest they will reform a semigel structure. Examples of substances used to create this useful effect are cationic modified montmorillonite clays that are approximated by the formula  $(Al,Mg)_2(SiO_2)(OH)_2 \cdot nH_2O$ . Treating these clays with quaternary ammonium compounds will render them organophilic. Stearalkonium hectorite is the most frequently used of these clays. The main disadvantage of clay additives is that they lower surface gloss. This can be offset by the addition of various polymers, for example, acrylate copolymers and nylon. These additives improve gloss, as well as toughness and scratch resistance. Amorphous (noncrystalline) silica is also used as a viscosity modifier at very low levels.

### Stabilizers

Color stability is a very important property in nail varnishes. Special stabilizers are added to nail varnishes to prevent the colors from fading and shifting. Nitrocellulose is usually the culprit, since it is inherently unstable in ultraviolet (UV) light. Solutions of nitrocellulose will change from a clear to a yellow to a brown liquid with relatively little UV light exposure. Pigments and dyes may also become unstable with longer periods of exposure. Lighter colored varnishes are less stable than darker colors. Sheerer varnishes with lower levels of colorant are more susceptible to UV light than richer varnishes with higher levels of colorant. Generally, varnishes with colors nearer to the blue end of the spectrum shift more readily and dramatically than colors found nearer to the red side. To help prevent discoloration problems, nail varnish formulations utilize UV light-absorbing stabilizers that absorb UV light and convert it into harmless visible light and infrared energy (heat). The most common of the stabilizers of this type are benzophenone-1 and octocrylene.

### Coloration Additives

Unless the nail varnish is clear and colorless, additives must be used to alter the opacity and shade. Color additives must have very low or no heavy metal content, to be certified by the Food and Drug Administration (FDA) and if sold internationally, it must also be allowed in the EU, Canada, and Japan. Occasionally, smaller manufacturers will risk using nonapproved colorants (e.g., "day-glo" colors) to satisfy the faddish demands of

younger consumers, but for the most part these regulations are adhered closely. Colorants must have relatively high light fastness and should not stain the nail plate. Colorants can be stabilized by precipitating a particular pigment with aluminum hydroxide to form a salt complex called a “pigment lake,” that is, D&C Red No. 7 Calcium Lake and D&C Yellow No. 5 Zirconium Lake. Pastel shades are achieved by the addition of titanium dioxide (TiO<sub>2</sub>). Ferric ferrocyanide (Prussian blue) is used in small amounts to enhance blues and alter other shades. To achieve complete pigment dispersion and suspension, high-energy ball or roll mills must be used to ensure uniform colors and to reduce the amount of colorant needed, that is, 2% dry colorant or less. Pearlescent pigments continue to be highly desirable commodities in modern varnishes. Bismuth oxychloride and mica coated with TiO<sub>2</sub> and other colorants are used to create the many beautiful iridescent shades. More complete information on approved colorants can be obtained from the CTFA’s *International Color Handbook* (now known as the Personal Care Product Council or PCPC) (13).

Colorants are usually indicated on the label by their international color index number (CI), which is accepted by most regulatory agencies around the world; however, sometimes both the CI and INCI nomenclatures are used, for example, CI 77891 (titanium dioxide), unless there is a lack of space on the label.

### Other Additives

A variety of highly specialized additives are known to those skilled in the art of nail varnish formulation. Even tiny amounts of many of these special additives can give dramatic differences in performance. Some examples are surfactants to improve wetting and adhesion and organic acids to stabilize colorants. However, some additives serve no function other than to increase consumer appeal. These include proteins, minerals, pearl, gem dusts, and vitamins.

### Base and Top Coats

Base coats are applied to the nail plate before application of the nail varnish. They are usually of similar composition to varnish but contain more additives, which improve adhesion and act to protect against staining of the nail. Top coats utilize higher levels of ingredients that maximize surface gloss and hardness. Often, the top coat contains special UV-absorbing materials to prevent discoloration. Not all top coats are evaporative coatings, since some are UV-cured urethane (meth)acrylate oligomers and blends (14).

#### *Film-Drying Accelerant*

Silicone oil blends and silicone oil-in-water emulsions are often used to accelerate nail varnish dry times. Film-drying accelerant is sprayed or brushed over freshly applied nail varnish to give rapid drying and increased protection from minor dents or surface scratches while remaining solvent evaporates from the coating, allowing it to reach a hard set. Drying is accelerated because the thickener’s microstructure collapses, allowing solvents to escape more quickly.

### Formaldehyde Controversy

Formaldehyde is an anhydrous gas and cannot be utilized as a cosmetic ingredient for that reason. When formaldehyde is mixed with water, it does not simply dissolve but instead

undergoes a chemical reaction that converts it from the aldehyde into methylene glycol and trace levels of free formaldehyde in equilibrium. Unfortunately all around the world, formalin is incorrectly thought of as aqueous formaldehyde, even by medical and scientific professionals. The so-called “formaldehyde releasing” preservatives do not release formaldehyde gas, but instead they release methylene glycol. Until recently, the INCI dictionary, which cosmetic product manufacturers are supposed to use to name their ingredients, incorrectly requires formalin to be called formaldehyde. No one worried about the misnaming until advocacy groups began saying that cosmetic products contain cancer-causing formaldehyde as an ingredient, which is clearly incorrect. The NMC petitioned INCI to address this issue and as of December 2008, the INCI name for formalin is methylene glycol.

The FDA allows the use of up to 5% formalin in nail hardeners and requires warning labels on nail-care products, as well as “nail shields that restrict application . . .” (15). EU regulations require “formaldehyde” warning labels when concentrations exceed 500 ppm formaldehyde gas. These levels of free formaldehyde gas are much greater than what is found in nail hardeners, which typically contain less than 12 ppm, based on equilibrium calculations for these products, which typically contain 1.5% formalin or less (16).

It is suspected that formalin cross-links proteins (17) in the nail, resulting in increase in surface hardness and decreased flexibility, which the user misinterprets as improved strength and durability. After months of continued use, nail hardeners may eventually increase nail plate hardness and rigidity to the point that brittleness becomes obvious. Users remember the early success of the hardener and usually respond to the brittleness by increasing the frequency of application. This leads to further cross-linking, and nails may end up in a worse condition than before. Onycholysis and abnormal growth of the hyponychium may be the results of prolonged formalin overexposure, but this is probably uncommon. Typically, these problems are a result of aggressive manicuring services (18).

### Microbiological Contamination and Water-Based Varnish

Microbiological studies commissioned in 2009 by the NMC show that traditional solvent-based nail polishes will quickly kill common pathogens without additional preservation and do not create the potential for transmitting pathogenic organisms (19). Water-based nail varnishes are available, but they cannot compare to the performance of traditional nail polishes and, being prone to bacterial contamination, must be preserved with, for example, quaternium (15).

### New Developments

New industry trends are turning toward UVA-curable top coats, base coats, and nail color, which applies like traditional nail varnish to form durable, long-lasting coating when exposed to low levels of UVA light. Also, nail varnishes that improve nail plate health are currently the hottest topics of interest for consumers. There is therefore a tremendous economic incentive for manufacturers to discover ingredients that provide demonstrable benefits to the nail. Improved nail toughness and solutions for yellow, dry, brittle, and splitting nails would be enormously beneficial. When these technologies are developed, it may eventually lead to the holy grail of nail

varnishes—one that truly prevents or helps treat common nail pathologies.

#### *Nail Varnish Solvents (Nail Varnish Remover)*

Acetone and/or butyl or ethyl acetate, methyl ethyl ketone, ethoxy ethanol, or similar compounds are used for rapid softening and solubilizing of nail polish, as well as to remove oils and waxes to cleanse and prepare the nail for varnish application. Some varnish removers claim to minimize stripping of moisture and oil from already brittle nails. The removers are based on solvents such as lactones or dimethyl esters of adipic, glutaric, and succinic acids (dibasic esters).

#### *Nail Creams and Lotions*

Oil-in-water emulsion preparations aid in softening the keratin of the nail plate and contiguous skin. This is achieved initially by the addition of water and, subsequently, by the reduction in evaporation of water from the nail. Cosmetic preparations are of two basic types: those designed to deliver water-soluble, hydrophilic substances into the nail plate and those designed to deliver hydrophobic substances, such as natural jojoba or almond oil. Once absorbed, these ingredients have the potential to plasticize, increasing flexibility, toughness, and durability, and are claimed to be especially useful for dry and/or brittle nails.

#### *Cuticle Removers*

These are lotions or gels containing approximately 2% to 4% sodium or potassium hydroxide (pH 12–13.5). They are applied in the vicinity of the cuticular ridge to eliminate the remnants of cuticle that adhere to the nail plate as it grows outward. The lotion is left in place for approximately one to two minutes and then washed off. In nail salons, the process is hastened by using a cuticle pusher. Creams containing low levels of  $\alpha$ -hydroxyacids are also used as cuticle removers. These usually contain 1% to 5% lactic acid (pH 2.5–3.5). Besides their ability to soften and remove cuticle, daily use can eliminate hangnails.

### **Adverse Reactions to Nail Cosmetic Procedures**

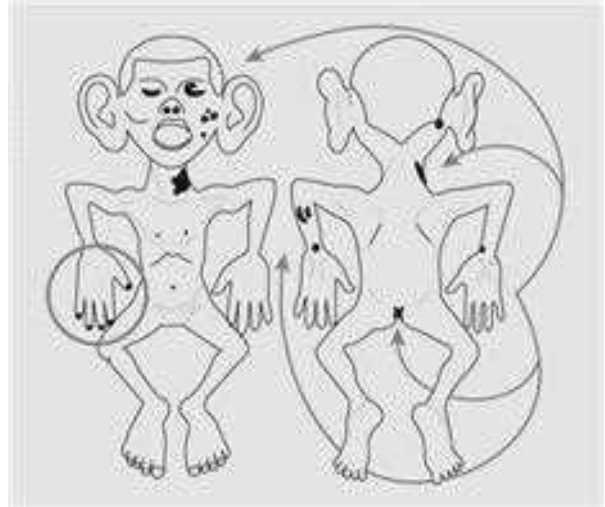
Adverse reactions to nail cosmetic procedures (20) may be divided into two main categories: reactions to applied cosmetics and nail tool/instrument damage.

### **REACTIONS TO APPLIED COSMETICS**

Cosmetics may produce reactions both at the site of application to the nail area and secondarily elsewhere on the body. The fingernails act as a reservoir for small amounts of cosmetic preparations transferred by the hand to other areas of skin, that is, face.

#### **Nail Varnish Dermatitis**

Nail varnish dermatitis of allergic origin can appear on any part of the body accessible to the nails (Fig. 31.10), but often with no signs in the nail apparatus. Exceptions, however, may exist, mainly in the periungual area (21) (Fig. 31.11). The eyelids (Fig. 31.12), the lower half of the face, the sides of the neck, and the upper chest are the most commonly affected areas (22,23). In addition to ectopic dermatitis, allergic airborne contact dermatitis caused by nail ingredients should be suspected when lesions on the face, neck, and ears are symmetrical (24). The allergen in nail varnish is usually thermoplastic resin. Diagnostic skin patch testing with nail varnish should be performed without



**Figure 31.10** Distribution of nail varnish ectopic dermatitis. *Source:* After G Bonu.



**Figure 31.11** Rechallenge of nail varnish onto two fingers only, showing severe local dermatitis. *Source:* Courtesy of Dr R. Staughton.



**Figure 31.12** Eyelid dermatitis.

occlusive covering, or with dry varnish films to avoid false-positive reactions from the solvent.

The thermoplastic resin used to promote adhesion is often the main culprit (25–28), but when the nail varnish is completely dry it is only a weak allergen (29). However, nail varnish that has completely dried on the fingernails contains water-soluble components that may reach the skin during extensive, transient contact (30). To make “formaldehyde-free” claims, cosmetic manufacturers have reformulated their nail varnish replacing TF resin with other resins, that is, tosylamide/epoxy resin [trade names Lustrabrite<sup>®</sup> and Nagellite<sup>®</sup>, a condensation product of bis-phenol A epoxy resin (31)], phthalic and trimellitic anhydride/glycol copolymer (32), glycerophthalic polyester resin (PhaseTM), 4-methylbenzene sulfonamide-epoxy resin (CliniqueTM), phthalic polyester resin (ShiseidoTM), or polyester saturated hydroxylated resin (DeborahTM) (33). Unfortunately, some of these and related “hypoallergenic” resins (34,35) have already produced distant contact dermatitis. Another potential exposure source is the (meth)acrylates used in some UVA-curable nail products.

The following substances should be included in a test battery:

- Tosylamide/epoxy resin (10% petrolatum)
- TSFR (10% petrolatum)
- Glyceryl phthalate resin (polymer resin) 10% petrolatum
- Formalin (1–2% methylene glycol in aqua)
- Phthalic and trimellitic anhydride (1% petrolatum)
- Colophony (resin) 10% or 20% petrolatum (36)
- Drometrizole (Tinuvin P) 1% to 5% petrolatum
- Nickel (0.5% petrolatum) and 1% dimethylglyoxine spot test for nickel from varnish mixing beads
- Benzalkonium chloride (0.01% to 0.1% water)

### Contact Urticaria

Recurrent urticaria involving the same area as contact dermatitis plus the distal phalanx of the fingers has been reported with isomorphic response to nail varnish testing, immediately after simple contact (37).

### Nail Plate Staining

Nail staining from the use of deeper shades of red and brown nail varnish is most commonly yellow-orange in color (38) (Fig. 31.13). Typically, it begins near the cuticle area, extends to the top of the nail, and becomes progressively darker from base to tip. Colorants such as D&C Red no. 6, 7, 34; FD&C Yellow no. 5 Lake can penetrate into the nail too deeply to be removed, but this can be significantly avoided with the use of a base coat prior to nail varnish application. Fingernail discoloration can be produced by chloroxine, an active ingredient in a shampoo used for control of seborrheic dermatitis is highly reactive to metals such as iron oxides commonly used as pigments in nail varnish, and it is likely that discoloration may result from a reaction between the two (39). Patients undergoing therapy with minocycline may develop discoloration of the nails (40). Analysis of the nail clippings from minocycline-treated women showed a large amount of iron concentrated only in discolored areas of the nail, which did not occur in women who did not varnish their nails, nor in men with nails free of a significant amount of iron. Nail discoloration may also result from the combined effect of nail varnish and dermatological treatment containing either resorcinol or resorcinol monoacetate (41).



**Figure 31.13** Yellow–orange nail-plate staining. *Source:* Courtesy of A Tosti.

### Nail Keratin Granulation

Injury to the nail from nail varnish is rare. However, “granulations” of nail keratin (Fig. 31.14), presenting as superficial friability (42), can sometimes be observed. In these cases, individuals continually remove old varnish and apply fresh coat over for periods of weeks. Nail keratin granulation may be avoided by lessening the frequency of removal and reapplication of nail varnish, that is, no more than once per week to avoid damaging the surface of the nail. These products contain acetone and/or butyl or ethyl acetate, methyl ethyl ketone, or similar compounds that can dehydrate the nail plate and decrease corneocyte adhesion, extract lipids, and contribute to brittleness (43). Some polish removers contain significant amounts of water (17%) and/or conditioners for skin, to reduce tissue damage, making them the preferred solvent for varnish removal. Oils are sometimes added to prevent excessive drying of the nail. Nail varnish removal may cause inflammation of the paronychia area when the solvent remover solution is left in contact with the skin. Rarely, irritant and allergic contact dermatitis, blistering, onycholysis, and brittleness may occur (43).



**Figure 31.14** “Granulation” of nail keratin.



Figure 31.15 Stick-on nail dressing.



Figure 31.16 Onycholysis due to overzealous manicure.

### Cuticle Removers and Softeners

Removers (see the preceding text) are designed to destroy keratin by attacking the disulfide bonds of cystine. After the nails have been soaked in soapy water, cuticle removers are applied and left in place for approximately two minutes before being washed off. The loose cuticle tissue is usually removed from the nail by being rubbed gently with a wooden stick covered with cotton. Removers should not be applied to the fibrous cuticular ridge, nor should this tissue be removed with sharp implements such as nippers or V-shaped curettes.

Cuticle softeners are often misnamed since they are actually designed to soften and moisturize the eponychium and lateral folds and not designed to remove cuticle tissue from the nail plate; the pH of these products is typically 4.5 to 6.0. Skin conditioners or softeners often contain substances such as quaternary ammonium or urea or  $\alpha$ -hydroxyacids at low concentrations and are used as emollient creams. Triethanolamine is used to adjust the product's pH and may act as a sensitizing agent (5% in petrolatum for patch testing).

### Stick-On Nail Dressing

"Stick-on nail dressings" (decorative coatings) are thin, clear, or colored synthetic films (Fig. 31.15) with an adhesive that fixes them firmly to the nail. Recently, decorative adhesive films have undergone a resurgence and become very popular. In some cases, pathologic changes (44) of traumatic origin are said to be produced in nails by the occlusive nature of the film. In fact, they can be attributed to a temporary overhydration of the nail plate. The same is true for any occlusive or semioclusive coating on the natural nail. For example, when the artificial nails are removed, the nail may feel weaker and thinner because of the higher moisture content increases flexibility. Press on nail extender tips are also used for temporary extension of the nail. Generally, these are only used for special occasions, that is, weddings, and are removed within a day or two.

### POTENTIAL FOR INJURY/INFECTION

Traumatic injuries from nail files, wooden or plastic sticks, and metal or porcelain spatulas may cause not only infection but also onycholysis (Fig. 31.16) and Beau's lines or transverse white streaks from overzealous manicuring, pedicuring, or filing on

the nail (45). It is, therefore, wise to use wooden sticks covered with cotton or instruments with blunt edges. Nail technicians usually remove too much of the natural nail plate with coarse abrasives and powered electric files, which should only be used on artificial nails. Cutting the nail with dull or blunt tools may contribute to increased weakening, peeling, fracturing, and splitting. Tools should be sharpened regularly or the blades changed when they become dull. An alternative method is to shape the fingernail with an abrasive board, filing from the sides of the nail toward the center.

Procedures for consistent and proper hand washing by all hospital personnel should be reinforced, as well as the maximum 3-mm rule for end-of-fingernail lengths (46). The subungual space of the hand is heavily colonized with microorganisms, and contaminated instruments may lead to acute bacterial or chronic *Candida* paronychia and onycholysis. Over-filing of the nail plate with coarse abrasives or heavy-handed filing techniques with even the mildest buffing block can disrupt the thin tissue seal that holds the plate to the bed and lead to onycholysis and possibly subsequently *Candida* or other infections. Acrylic nail extensions are also implicated in *Candida* nail bed infection (47), but much more commonly the issue is increased bacterial carriage versus natural nails (48), particularly *Staphylococcus aureus* and *S. epidermidis*, which are not uncommon under the free edge and are more difficult to remove out of this area despite surgical scrubs (49). In contrast to fresh nail polish worn on short healthy nails (50), chipped nail varnish is a known potential reservoir for bacterial growth on natural nails (49). In addition, bacterial carriage is higher in subjects with artificial nails than in those with natural nails, possibly because of the longer length of artificial nails and more surface area for colonization (51). Serious eye infections have also been reported following *Pseudomonas* involvement in the nail apparatus (52), as has subacute bacterial endocarditis after nail trauma (53).

Warts can affect mainly the periungual tissue and sometimes are found on the proximal nail fold as a result of nail biting or other insult (54). In the mid-90s, a woman was awarded \$3.1 million after contracting herpes on all 10 fingers at a salon (55).

Transmission of more serious diseases such as hepatitis B and AIDS (HIV) seems to be virtually impossible through nail

services. The approximately 200,000 nail technicians in the United States perform on average about 20 to 25 services per week. Since 1985, very conservative estimates are that over 5 billion nail services have been performed without a single identified or suspected case of HIV or hepatitis B transmission. If this type of transmission were possible, a noticeable increase in unexplained infections in women who frequent salons would have been noticed, but no such link has ever been discovered. Of course, all infectious complications can be avoided with effective sanitary practices, and this has become an increasingly important focus in nail salons.

## Sanitation and Disinfection Practices

### Sanitation

The public generally does not understand that "to sanitize" simply means low-level cleaning, in which potentially harmful microorganisms are reduced to levels considered safe by public health standards. The simple act of wiping an object with soap and water is a method of sanitizing. The public often confuses sanitation with disinfection. Even so, sanitation/sanitizing is a primary method for infection control and must be properly preformed or disinfection procedures will be less effective.

### Disinfection

This is the elimination of most potentially harmful microorganisms, except bacterial spores, on a surface. U.S. Environmental Protection Agency (EPA)-registered disinfectants are authorized for use only on hard, nonporous surfaces, since this is how their efficacy verified. Bleach and alcohol are examples of effective disinfectants that existed before the creation of the EPA and therefore they do not require EPA registration. It is against U.S. federal law to use and EPA-registered disinfectant in a manner contrary to its registration; therefore, soft or porous surfaces can be disinfected with appropriate bleach or alcohol solutions and meet EPA requirements, if properly preformed. In American nail salons, most State Board's of Cosmetology regulations generally require that hard, nonporous implements be thoroughly washed and then disinfected for 10 minutes in an EPA-registered disinfectants that are virucidal, fungicidal, and bactericidal.

Wooden sticks, cotton balls, emery boards, and certain types of abrasive files are considered single use items that should be disposed off after one use. These items should not be stored or put aside for one specific client only, since this can contribute to spread of microorganisms in the salon. Even so, salon disinfection regulations nationwide are confusing and, in many cases, antiquated or use incorrect terminology, that is, interchanging "sanitize" with "disinfect." Each licensed nail technician receives training in the best practices of sanitation and disinfection during the course of their education and must pass an examination, but sometimes this information is not properly taught or fully understood.

Improper cleaning and disinfection probably account for the vast majority of salon-related infections that would be prevented by adhering to the proper guidelines. A comprehensive set of recommendations for cleaning and disinfecting both manicure and pedicure equipment in salons has been developed by the NMC and is available for free will download in several languages (56). These recommendations have been accepted and endorsed by competent associations in the United States, EU, Australia, and Korea.

Some prefer to bring their own clippers or other implements, but doing so means a loss of all control over these

devices. Patrons have been known to use them on other family members and even their pets. Nail professionals must clean and disinfect all implements *prior* to use on a client. Because of time constraints, this is almost never done; therefore this practice should be discouraged.

### Sterilization

Complete elimination of living organisms, including viruses, bacteria, and bacterial spores, from a surface is required to achieve sterilization. Ethanol 90% (effective against herpes) and 10% sodium hypochlorite (bleach) work well if instruments are fully submerged for 10 minutes. Some authorities are convinced that glutaraldehyde should not be recommended for salons claiming that the risks of overexposure in this use do not warrant using potentially unsafe, toxic, and highly aggressive pesticides.

Autoclaves are growing in popularity, but some experts estimate that less than 1% of the salons in the United States use autoclaves. Those that do often do not properly maintain the units or verify their efficacy by spore testing, as required. Because of the negative press and positive PR value of using and autoclaves, this trend is expected to continue. Use of autoclaves is far more common in Australia, due to government regulations. An interesting development is that several companies have set up services, which sterilize implements for salons. Sterilization will never replace disinfection and salon since many items that come in contact with patrons are too large to fit in autoclaves and therefore must be properly cleaned and disinfected before reuse.

## REFERENCES

1. Alkiewicz J, Pfister R. Atlas der Nagelkrankheiten. Stuttgart: Schatthauer-Verlag, 1976.
2. Brosche T, Dressler S, Platt D. Age-associated changes in integral cholesterol and cholesterol sulfate concentrations in human scalp hair and finger nail clippings. *Aging Clin Exp Res* 2001; 13:131-138.
3. Brauer E, Baran R. Cosmetics: the care and adornment of the nail. In: De Berker D, Haneke E, Tosti A, eds. *Baran & Dawber's Diseases of the Nails and their Management*. 3rd ed. Oxford: Blackwell Science, 2001.
4. Mallavarapu L. US Patent 4,996,284, 1991.
5. Schlossman ML. US Patent 4,301,046 (to Tevco), 1981.
6. Lecaheur M, Mutterer J, Wimmer E. French Patent 9202486, 1992.
7. Schlossman ML. Nail cosmetics. *Cosmet Toil* 1986; 101:24.
8. Schlossman ML. Advances in nail enamel technology. *J Soc Cosmet Chem* 1992; 43:331-337.
9. California Environmental Protection Agency. Office of Environmental Health Hazard Assessment Proposition 65. Implementation. Sacramento, CA: California Environmental Protection Agency, 1986.
10. Donald JM, Hooper K. Hopenhayen-Rich. Reproductive and Development Toxicity of Toluene: a Review. Sacramento, CA: California Department of Health Services, Health Hazard Assessment Division.
11. Schoon D. The truth about toluene. *Nails Magazine* 1994; Nov: 76.
12. Environmental Protection Agency. Federal Register, 40 CFR, part 51 and 59, National Volatile Organic Compound Admission Standards for Aerosol Coating-Final Rule, June 23, 2009.
13. CTFA. International Color Handbook. Washington, DC: Cosmetics, Toiletries and Fragrance Association, 1992.
14. Schoon D. Nail Polish Chemistry, Nail Structure and Product Chemistry, 2nd ed. Albany, NY: Thomson/Delmar Publishing, 2005:122-127.
15. FDA. Cosmetic Handbook, June 1989.
16. Winkelman JGM, et al. Kinetics and chemical equilibrium of the hydration of formaldehyde. *Chem Engin Sci* 2002; 57:4067.



17. Kiernan JA. Formaldehyde, formalin, paraformaldehyde and glutaraldehyde: what they are and what they do. *Microsc Today* 2000; 1:8.
18. Baran R, Dawber R, deBerker D, et al. *Cosmetics: The Care and Adornment of the Nail, Disease of the Nails and their Management*. 3rd ed. Blackwell Science, 2001:367.
19. Nail Manufacturers Council (NMC) data, publication forthcoming.
20. Baran R. Nail cosmetics. Allergies and irritations. *Am J Clin Dermatol* 2002; 3:547-555.
21. Liden C, Berg M, Färm G, et al. Nail varnish allergy with far-reaching consequences. *Br J Dermatol* 1993; 123:57-62.
22. Calnan CD, Sarkany J. Studies in contact dermatitis: nail varnish. *Trans St John's Hosp Dermatol Soc* 1958; 40:1-11.
23. Schorr WF. Nail polish allergy. *Dermatol Allergy* 1981; 4:23.
24. Dooms-Goossens E. Contact dermatitis caused by airborne agents. *J Am Acad Dermatol* 1986; 15:1-18.
25. Tosti A, Guerra L, Vincenzi C, et al. Contact sensitization caused by toluene sulfonamide-formaldehyde resin in women who use nail cosmetics. *Am J Contact Dermatitis* 1993; 3:150-153.
26. Hausen BM. Nagellack-Allergie. *Z Hautkr* 1994; 69:252-262.
27. Anonide A, Usiglio D, Pestarino A, et al. Frequency of positivity to nail varnish allergens. Study of eighty women. *G Ital Dermatol Venereol* 1995; 130:13-16.
28. De Groot AC, Weyland JW, Nater JP. *Unwanted Effects of Cosmetics and Drugs used in Dermatology*. 3rd ed. Amsterdam: Elsevier, 1993:524-529.
29. Fisher AA. *Contact Dermatitis*. Philadelphia: Lea & Febiger, 1986.
30. Hausen BM, Milbrodt M, Koenig WA. The allergens of nail polish. *Contact Dermatitis* 1995; 33:157-164.
31. Lee HN, Pokorny CD, Law S, et al. Cross-reactivity among epoxy acrylates and bisphenol F epoxy resins in patients with bisphenol A epoxy resin sensitivity. *Am J Contact Dermatitis* 2002; 13:108-115.
32. Moffitt DL, Sansom JE. Allergic contact dermatitis from phthalic anhydride/trimellitic anhydride/glycols copolymer in nail varnish. *Contact Dermatitis* 2002; 46:236.
33. Giorgini S, Brusi C, Francalanci S, et al. Prevention of allergic contact dermatitis from nail varnishes and hardeners. *Contact Dermatitis* 1994; 31:325.
34. Shaw S. A case of contact dermatitis from hypoallergenic nail varnish. *Contact Dermatitis* 1989; 20:385.
35. Kanerva L, Lauerma A, Jolanki R, et al. Methyl acrylate: a new sensitizer in nail lacquer. *Contact Dermatitis* 1995; 33:203-204.
36. Cronin E. *Contact Dermatitis*. Edinburgh: Churchill Livingstone, 1980:150-157.
37. Bonu G, Zina G. Reazione da contatto morfologicamente inconsueta. *Minerva Dermatol* 1959; 33:507-509.
38. Calnan CD. Reactions to artificial colouring materials. *J Soc Cosmet Chem* 1987; 18:215-223.
39. Cortese TA. Capitol shampoo, nail discoloration. *The Schoch Letter* 1981; 31, item 154.
40. Gordon G, Sparano BM, Iatropulos MJ. Hyperpigmentation of the skin associated with minocycline therapy. *Arch Dermatol* 1985; 121:618-623.
41. Loveman AB, Fliegelman MT. Discoloration of the nails. Concomitant use of nail lacquer with resorcinol or resorcinol acetate as a cause. *Arch Dermatol* 1955; 72:153-156.
42. Baran R. Pathology induced by the application of cosmetics to the nail. In: Frost P, Horowitz SN, eds. *Principles of Cosmetics for the Dermatologist*. St Louis: Mosby, 1982:181-184.
43. Kechijian P. Nail polish removers. Are they harmful? *Semin Dermatol* 1991; 10:26-28.
44. Samman PD. Onychia due to synthetic coverings. Experimental studies. *Trans St John's Hosp Dermatol Soc* 1961; 46:68-73.
45. Baran R. Nail beauty therapy: an attractive enhancement or a potential hazard? *J Cosmet Dermatol* 2002; 1:24-29.
46. Jackson EM. Some hospitals ban artificial nails. *Cosmet Dermatol* 2001; 14:52-53.
47. Symonds J, O'Dell CA. Candida nail bed infection and cosmetic acrylic nail extension - a potential source of hospital infection? *J Hosp Infect* 1993; 23:243-247.
48. Pottinger J, Burns S, Manske C. Bacterial carriage by artificial versus natural nails. *Am J Infect Control* 1989; 17:340-344.
49. Wynd CA, Samstag DE, Lapp AM. Bacterial carriage on the fingernails of OR nurses. *AORN J* 1994; 60:796-805.
50. Baumgardner CA, Maragos CS, Walz JA, et al. Effects of nail polish on microbial growth of fingernails. *AORN J* 1993; 58:84-88.
51. Senay H. Acrylic nails and transmission of infection. *Can J Infect Control* 1991; 6:52.
52. Parker AV, Cohen EJ, Arentsen JJ. *Pseudomonas* corneal ulcers after artificial fingernail injuries. *Am J Ophthalmol* 1989; 107:548-549.
53. Aderka D. Bacterial endocarditis following nail trauma. *Arch Intern Med* 1988; 148:752-754.
54. Schoon D. *Nail Structure and Product Chemistry*. 2nd ed. Albany, NY: Milady/Delmar Publishing, 2005:66-67.
55. ABC NEWS.com: Woman gets \$3.1 M in herpes manicure case.
56. Nail Manufacturers Council (NMC), A series of safety related brochures for nail technicians, Professional Beauty Association, Scottsdale, Arizona, available at: [www.probeauty.org/NMC](http://www.probeauty.org/NMC).

## Cosmetics for abnormal and pathological nails

Douglas Schoon and Robert Baran

### INTRODUCTION

Medical or surgical nail disorders can sometimes be camouflaged by cosmetic nail techniques. This, however, covers up the underlying process, and proper diagnosis and therapy are therefore essential to correct the underlying condition (1).

There are limits to the use of cosmetics, such as acrylic chemicals, in some at-risk patients: those who have had a reaction to artificial nails in the past, for example, or individuals with circulatory disorders, particularly with scarring or ulceration around the fingertip. Any bacterial or fungal infection should be treated before applying any type of artificial nail. Individuals whose hands are in water for long periods will have difficulty keeping on artificial nails. Psoriasis produces an isomorphic reaction (2), so artificial nails should be avoided in persons affected by this condition, since nicking the eponychia or nail folds may provoke a Koebner reaction. Lichen planus and lupus erythematosus may also precipitate this type of reaction. If the condition is minor or temporary, that is, waiting for hangnails to heal, then artificial nails are acceptable; however, for potentially chronic conditions such as onycholysis, it might be prudent to avoid artificial nails until the condition is resolved. This will avoid medicolegal problems (3). For the same reasons, an ultraviolet (UV) light-cured acrylic should never be used in people who are taking photosensitizing medications, or who are affected by photodermatitis.

### ARTIFICIAL NAILS

There are three major methods for applying artificial nails: approximately 30% are sculptured on a form, 60% are molded on an acrylonitrile butadiene styrene (ABS) plastic tip, and 10% are applied as thin overlay on the natural nail. Each is popular for a variety of reasons.

- All three methods can correct the coloration of nail plates or beds.
- Each method can build a natural-looking curvature to a flat natural nail.
- All will increase the durability of the nail plate and may be decorated with colors, designs, ornaments, and jewels.
- Each type can attractively replace a deteriorated nail plate, one reduced by onychophagia (e.g., affected by splitting), or one that is simply broken—acrylics can even cosmetically correct ski-jump nails or the unsightly racket nails.
- Sculpting and plastic tips specifically add length beyond the free edge and can create the illusion of a longer nail bed.
- Plastic tips require less technical skill to create a natural-looking nail.
- Natural nail overlays add no length and require lower maintenance while providing a protective coating. Artifi-

cial nail products are applied both in salons and in the home. Since the sculpting technique requires considerably more skill, it is usually restricted to the salon setting.

There are three basic types of product used to perform these services; they share similar ingredients, but feature different chemistries. All three are discussed in this chapter. They are “liquid/powder” (methacrylate based), “UV gels” [(meth)acrylate based], and “wraps” (cyanoacrylate based). In this chapter the term (meth)acrylate will be used to indicate methacrylates and/or acrylates.

A typical methacrylate liquid/powder-based kit contains (4)

- a metallized paperboard template, placed on the natural nail surface to frame the new nail for sculpting;
- a liquid methyl<sup>a</sup>, ethyl or isobutyl methacrylate monomer blend containing proprietary blends of other mono-, di-, tri-, and tetrafunctional methacrylate monomers;
- a powdered, spherical polymer made from poly(methyl methacrylate) and/or poly(ethyl methacrylate) polymer (or a copolymer of both methacrylates) with benzoyl peroxide as an initiator;
- a stabilizer such as resorcinol, eugenol, thymol or (most commonly) hydroquinone (HQ) or methyl ethyl hydroquinone (MEHQ);
- a catalyst, such as *N,N*-dimethyl-*P*-toluidine to catalyze the production of free radicals from benzoyl peroxide in the polymer powder;
- plasticizers such as tricresyl phosphate;
- very low levels of solvents to act as clarifiers or solubilizers; and
- dyes.

In salons, metalized nail forms (Fig. 32.1) and mylar-coated nail forms predominate over reusable.

Teflon nail forms (Fig. 32.2).

The nail is first thoroughly cleansed by brushing with soap and water and often painted with antiseptic solutions.

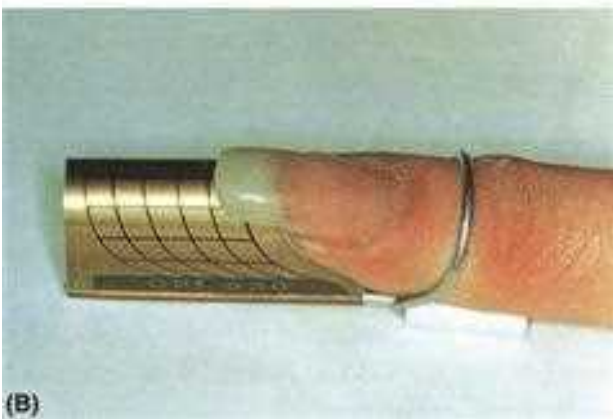
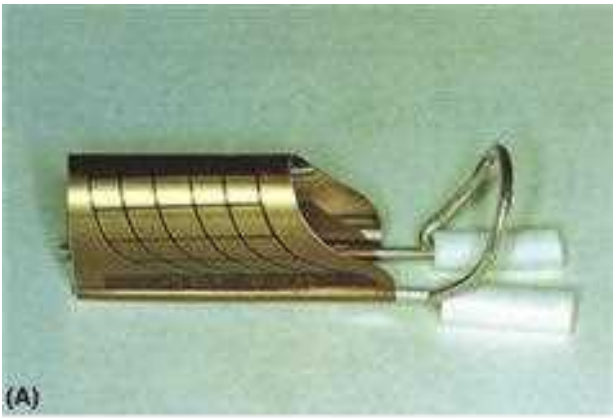
The dried nail is sometimes coated with an adhesion promoting primer. In the past these primers were based on diluted methacrylic acid, but developed acid-free primers are designed to react covalently with the keratin and the acrylic, providing increased adhesion to both surfaces.

Primers are “adhesion promoters.” Nonmethacrylic acid primers are adhesion promoters in a solvent base, and are not corrosive and therefore not likely to burn the soft tissue on contact, as is the case with methacrylic acid. Newer artificial

<sup>a</sup>Methyl methacrylate monomer is specifically prohibited for use to create artificial nails in most U.S. states and Australia.



**Figure 32.1** Metalized paperboard template for sculptured artificial nails.



**Figure 32.2** (A, B) Teflon templates for sculptured artificial nails.

nail formulations no longer require pretreatment of the nail with a primer.

Using a paper or Teflon nail form, the natural nail is coated with a fresh acrylic mixture that hardens at room tem-

perature in less than three minutes. The prosthetic nail is enlarged by repeated applications. The sculptured nail can be filed and manicured to shape, and as the nail grows out, further applications of the acrylic mixture are added every two to three weeks to fill in the new growth of nail plate at the lunula. These types of service can be performed by sculpting either on a form or over a tip.

Colored polymer powders can create the illusion of a beautiful nail by using a combination of natural pink color over the nail bed and opaque white distally for the nail plate's free edge. This combination perfectly simulates a natural nail and nail varnish need not be used. Various shades of pink powders are used to hide visible defects in the nail bed and plate.

### ALLERGIC REACTIONS

These may occur two to four months, and even as long as 16 months, after the first application (5). One of the first indications is an itch in the nail bed. Paronychia, which is usually present in allergic reactions, can be associated with excruciating pain in the nail area, and sometimes with paresthesia. The nail bed is dry and thickened (Fig. 32.3), and there is often onycholysis (Fig. 32.4). The natural nail plate may appear thinner



**Figure 32.3** Nail bed and hyponychium thickening from sculptured artificial nails.



**Figure 32.4** Onycholysis due to sculptured artificial nails.

(Fig. 32.5), split, and sometimes discolored. It takes several months for the nails appearance to return to normal. Permanent nail loss (Fig. 32.6) is exceptional, as is intractable prolonged paresthesia (6–8). Distant allergic contact dermatitis may affect the face and the eyelids (9), and is probably caused by touching the face with the hands. The arms and wrists of nail technicians may be affected if these areas are repeatedly exposed to filing dusts. Filings contain small amounts of monomer that has not yet reacted, since it takes 24 to 48 hours for the enhancement to cure fully.

Technicians should be instructed to wash their hands before touching the face or eye area. The area involved is usually the chin, where some technicians tend to rest their heads in their hands. They should also be warned to avoid contact with the dust of freshly applied product and to avoid using the product with too high a ratio of liquid to powder.

A medium dry consistency of the slurry is considered ideal. The filings from UV gel nails (discussed below) are also responsible for skin sensitizations.

The UV bulbs used to cure this type of artificial nail system lose about half of their original peak UV output after about four to six months, depending on usage.



**Figure 32.5** Thinning of the nail plate after use of sculptured artificial nails.



**Figure 32.6** Permanent loss of the nails due to sculptured artificial nails. Source: Courtesy of A. Fisher.

Technicians should be told to change the UV bulbs in their lights three times per year, even though they will continue to emit visible blue light for many years. Applying multiple thinner coats of products, rather than fewer and thicker coats, is preferred. The thicker the coating, the more difficult it is to cure the gel. UV penetration is low and the number of photons reaching beyond a depth of 2 mm is greatly reduced and a complete cure cannot be assured if applied too thickly. Although sensitization to butylhydroxytoluene is possible, gels use acrylated oligomers and monomers. Acrylates are many times more likely to cause sensitization than methacrylates or stabilizers. These systems also rely on photoinitiators, such as benzoyldimethyl ketal or camphorquinone (1–3%) or benzophenone, which can all be sensitizing.

Glutaraldehyde and acrylic acid are also sometimes used in low levels (<1%), as keratin adhesion promoters and certainly contribute to adverse skin reactions. Since UV gels contain oligomers with high molecular weights, they tend to be very sticky and messy, which further increases the risks of overexposure.

### Patch Testing to Identify Reactions to Sculptured Artificial Nails

Patients who are allergic react strongly to the acrylic liquid monomer (10) (1–5% monomer in petrolatum or olive oil). In the series of 11 patients of Koppula et al. (10), 0.1% ethyl acrylate in petrolatum detected 91% of the acrylate-allergic users of artificial nails. These authors proposed the following five chemicals be used as screens: ethyl acrylate, 2-hydroxy ethyl acrylate, ethylene glycol dimethacrylate, ethyl cyanoacrylate, and triethylene glycol diacrylate. The pattern of acrylate cross-reactivity among the most frequently positive acrylates suggests that a functional group that is a carboxyethyl side group may be requisite for allergic contact dermatitis to acrylates. Kanerva et al. (11) reported that six out of 23 patients who were acrylate sensitive were sensitive to ethyl methacrylate, which is consequently a significant allergen.

The powder contains ethyl methacrylate homopolymer or ethyl/methyl methacrylate copolymer, but also small amounts of monomeric methyl methacrylate monomer and ethyl methacrylate (<0.1%) and up to 2% benzoyl peroxide. This explains why the powder may in some cases provoke an allergic patch test reaction (11,12). Benzophenone and other UV light absorbers used in nail enhancement may produce eyelid dermatitis (13).

UV absorbers are often used at low levels (<1%) to protect the coating from UV-related discoloration.

Since there are no real monomer-free acrylic resins, an adaptable nail prosthesis made of silicone rubber is sometimes an alternative.

This “thimble-shaped” finger cover takes nail polish well (Fig. 32.7) (14,15). A recent development is for UV gel nail systems to be used as prosthetic devices for toes (Dr Robert Spaulding, personal communication).

### NONALLERGIC REACTIONS

With continued wear the edges of the sculptured nails become loose. These must be filed or clipped and then rebuilt to prevent development of an environment prone to bacterial and, beneath the nail plate, *Candida* infection. In fact, this is a result of improper application and maintenance. Failure to undergo



**Figure 32.7** Adaptable nail prosthesis made of silicone rubber.

filling every two to three weeks may result in creation of a lever arm that can predispose to traumatic onycholysis or damage to the natural nail. Older clients' nails grow much more slowly and require regular maintenance less frequently.

Onycholysis (16) is more common with nail extensions that are too long (lever effect). It has also been said that the bond between the sculptured and the natural nail can be stronger than the adhesion between the nail plate and the nail bed. There is no evidence that an occlusive prosthetic nail interferes with the nail's normal vapor exchange. Irritant reactions to monomers are possible (4). These are manifest as a thickening of the nail bed's keratin layer, which can sometimes cause the entire nail bed to thicken, with or without onycholysis. Still, without question, the overwhelming majority of cases result from physical trauma or abuse.

Damage to the natural nail is not unusual after two to four months of wear of a sculptured nail. If it becomes yellow or crumbly, this means that the product was applied and maintained incorrectly.

Higher-quality products, which are properly prepared, do not suffer from these problems. Therefore, instead of recommending wearing prosthetic nails for no more than three consecutive months with one-month intervals before resuming applications (17), or the dermatologist should find a better-qualified nail technician. It is probably unrealistic to assume

that clients will remove their artificial nails for any period. The problem may well not be the acrylic nail materials but rather the thinning of the nail due to overfilling with heavy abrasives. Acid-based primer (methacrylic acid) is a strong irritant, which may produce third-degree burns, so it is fortunate these are rarely used any longer. Acid-based primer is hazardous if one floods the soft, living tissue, neglects to wash up spills immediately, or ignores an individual complaining of burning. One must rinse any area immediately with water when the client says it is burning. Acid primer can permeate the plate and soak the nail bed if the nails are too thin. Soap or baking soda, used with water, are excellent neutralizers. If acid primer gets in the eyes, the eyes should be flushed with water for at least 15 minutes, making sure all traces of the chemical have been rinsed, then a poison control center should be called and emergency medical treatment sought. There is a general tendency to disregard manufacturers' instructions and warnings, which causes the majority of disorders.

### Contact Urticaria

Butylhydroxytoluene has been reported as a cause of non-allergic contact urticaria (18).

### Removing Sculptured Artificial Nails and Nail Polish

Acetone is the primary solvent used to remove artificial nails. Usually, 20 to 30 minutes is all that is required for methacrylate-based, liquid/powder systems. Most UV gels are extremely difficult to remove with solvent, so they are more frequently removed by filing with a coarse abrasive. The use of acetone-free nail polish remover on painted nails is not necessarily desirable. The alternative solvents, especially methyl ethyl ketone, have higher orders of toxicity and can damage the underlying polymer surface. Acetone diluted with 10% water works well for removing colored polish without excessively drying the skin or damaging the artificial nail. Reports have been published of severe and even fatal cases following ingestion or inhalation of acetonitrile-containing nail polish and acrylic nail removers, because the acetonitrile is metabolized into cyanide (19–22). Nitroethane poisoning from artificial finger nail remover has led to cyanosis and 39% methemoglobinemia (23). Ethyl methacrylate monomer and polymer nails and the UV or photobonded variety may produce severe and prolonged paresthesia, even without associated allergic dermatitis (3), but this is relatively rare. Unfortunately, the product the patient was using could have contained methyl methacrylate monomer, since this ingredient is used in gray market products, but not by mainstream manufacturers; it is often not disclosed in the ingredient listing.

### LIGHT-CURING GELS (UV GEL SYSTEMS: GEL NAILS)

The word gel applies to the form of the product—not the product itself. UV gel systems require no premixing of a powder component and are either acrylate or methacrylate based (approximately 30% of the market worldwide).

Cyanoacrylate-based “no-light gels” 1% or less of the market worldwide) do not cure via UV light or photochemical reaction (11). These products cure via moisture and can be accelerated with internal or externally applied catalyst. Both have very little odor, makes them popular in full-service beauty

salons and spas seeking to create a relaxing environment. UV gels may also require the use of a nail primer. The thick UV gel is brushed on the nail and cured with either UV or visible light, although visible light systems are rarely used since the visible light lamps produce large quantities of heat.

UV light-cured gels are the best known. These gels contain urethane (meth)acrylate and/or epoxy urethane oligomers and mono- and difunctional (meth)acrylate monomers for cross-linking and viscosity reduction, one or more photoinitiators, plasticizers, adhesion promoters, stabilizers, antiyellowing agents, colorants and a UVA light source/unit. Many of the same types of ingredients used in two-part methacrylate systems are also found in UV gels. Despite the fact that some products are marketed as being “not acrylics,” all two-part liquid/powder systems and UV gel systems based on the acrylic chemistry. The gel remains in a semiliquid form until cured under a UV lamp (two to three minutes per applied layer). The proportion of oligomeric resins to monomers determines the gel consistency. When the gel is exposed to light of an appropriate wavelength (UVA), polymerization occurs, resulting in hardening of the UV gel. UV gels do not require external catalysts and often, do not require primers. The newest trend is to create systems with a much lower potential for adverse reactions by avoiding the use of acrylates, relying instead on methacrylates with a lower potential for adverse reactions. Newer formulations also use very low levels of highly efficient photoinitiators and avoiding reliance on acrylic acid and glutaraldehyde for adhesion promotion. Visible light systems work in a similar fashion and are also composed of either urethane acrylate or urethane ethacrylate. The main difference is in the choice of a photoinitiator, which is sensitive to visible light.

No-light cyanoacrylate gels have a completely separate type of chemistry, utilizing a spray or a brush-on or dropper-applied activator, usually *N,N*-dimethyl-*P*-toluidine. In spray setting gels a thermal initiator replaces the photoinitiator. UV lights and primer are never used with cyanoacrylate gels. Individuals with a distal fissure or men who bite their nails may want more attractive hands, but shy away from liquid/powder systems. A UV or no-light gel-coated nail can look completely natural, and the smooth hard finish will make the nail more resistant to chewing and picking. Of course, a natural nail overlay can be accomplished with any type of system.

UV gels can also be used as tip overlays for individuals who want to extend the length of the nail plate, however, cyanoacrylate-based gels. Do not have the necessary strength to extend beyond the tip of the finger nail. Some companies provide a thicker UV gel designed for building and sculpting nail extensions. Some UV gels may also be used as a “sealer” that can also be used over nail varnish, making it more impervious to clipping, wearing and fading. However, the difficulty in removing the sealer is a consideration when evaluating the usefulness of this technique.

## COLORED GELS

Like colored methacrylate powders, colored UV gels are sometimes recommended to persons who do not often change polish color or to create nail art designs. They are noted for easy application, high shine, and durability. However, if nail infection or onycholysis occurs, the permanently colored gel makes detection nearly impossible. Also, colored pigments and dyes usually block UV penetration, making them more difficult to cure completely.

## REMOVING GELS

Since many gels slowly embrittle and degrade with continued UV exposure, that is, tanning bed and natural sunlight, they must usually be removed every two to three months.

The best way to remove UV gels is to let the nails grow out or to carefully file them off with heavy abrasives.

Acetone will have no effect on most UV gels, unless the majority of the thickness had been previously reduced by filing. This is a serious disadvantage that UV gel promoters ignore until recently when they make claims that these types of artificial nail are “safer” or healthier for the nail, when in fact they are no better than any other system. History has shown that nail technicians’ knowledge and skill are the primary determinants for successful application and for avoiding nail damage or other adverse reactions.

## REMOVABLE UV GELS

The latest trend in UV curable gels is to make products that can be removed easily. This is usually accomplished by either lowering the amount of cross-linking monomers, therefore lowering the cost link density of the artificial nail or by using an insufficient amount of photoinitiator and creating a partially cured artificial nail or a combination of both. These products generally require 30 minutes soaking in acetone to remove them.

## ADVERSE REACTIONS

Artificial nails shrink when they polymerized.

UV gel enhancement shrink by up to 18%, which can result in adhesion loss feel tight on the nail, throbbing or feel warmth below the nail plate. This may lead to tender, sore fingertips, but usually the condition resolves within a day or two. Adverse nail reactions, even with nail loss (24) and paresthesia with UV gels, have been observed (25).

UV-cured acrylates sensitize in many applications, including inks, lacquers, composite dental resins, audiological ear molds and nail cosmetics (26–30). In patients wearing UV-cured acrylic nails who had perionychial and subungual eczema with fingertip fissuring extending under the nails (31), Hemmer et al. (32) patch tested “hypoallergenic” commercial products.

The omission of irritant methacrylic acid primers from use with UV curable gels does not reduce the sensitizing potential of acrylate systems, since they still contain several other potential sensitizers. In contrast to the manufacturers’ declaration, all hypoallergenic products continue to include (meth)acrylated functional monomers and oligomers, and therefore continue to cause allergic sensitization.

UV gels and two-part liquid/powder systems (commonly called acrylics nails) share many similar ingredients, but are compositionally distinct enough that they will not necessarily cross-react (11,24). The resistance of disposable latex gloves to penetration by (meth)acrylates is low (33,34). Disposable nitrile or vinyl gloves are better alternative, since their resistance to methacrylates is much higher than latex.

## Preformed Artificial Nails

Plastic press-on nails are preformed by injection molding with the thermoplastic resin ABS and temporarily glued with cyanoacrylate to the nail (Fig. 32.8). They are packaged in several shapes and sizes to conform to normal nail plate configurations. They come in two types.



Figure 32.8 Preformed plastic nail "tips."

1. Those that are adhered to the free edge of the nail plate to act as a platform to support artificial nail coatings
2. Those that are adhered over the entire nail plate as a temporary application for special occasions, for example, weddings and high school

Decorative, preformed nails in gold plate (Fig. 32.9) may be used in the same way as plastic nails. The application of preformed prosthetic nails is limited by the need for some normal nail to be present for attachment (Fig. 32.10). When used alone (listed item 2 above) it is recommended that they are removed after one or two days at a time, as they are not very durable and have sometimes caused onycholysis and nail surface damage. Since these tips are adhered by using cyanoacrylate, in some cases they can produce allergic changes indistinguishable from dermatitis caused by formaldehyde nail hardeners. Ectopic allergic or irritant contact dermatitis may affect the face and eyelids (35) and large areas of the trunk (36), and disappear with removal of the cause.

Allergic onychia and paronychia due to cyanoacrylate nail preparations require some comment (9,37). After about three months, painful paronychia, onychia, dystrophy, and discoloration of the nails may become apparent and last for several months (Fig. 32.11).

Eyelid dermatitis disappears with removal of the allergen. Shelley and Shelley (38) reported an isolated chronic allergic contact dermatitis simulating a plaque of parapsoriasis due to an allergic reaction to cyanoacrylate adhesive used on the fingernails.

Not surprisingly, patients react far more often on patch testing to the adhesive than to the plastic nails.

Suggested allergens for patch testing are

- *P-t*-butyl phenol resin (1% petrolatum) (39,40),
- tricresyl ethyl phthalate (5% petrolatum),
- cyanoacrylate adhesives (10% petrolatum),
- 5% methyl ethyl ketones,
- MEHQ or HQ, and
- the artificial nail itself.

Most cyanoacrylate adhesive formulations contain HQ at concentrations up to 1000 ppm, but more typically 200 ppm. The European Union has put a 200 ppm limit for HQ in



Figure 32.9 Preformed nail in gold plate.

artificial nail systems (after mixing if contained in a two-part system) (41).

Therefore, most investigators perform patch testing not only with cyanoacrylate glue or nail preparations as such, but also with HQ.

### NAIL MENDING AND WRAPPING

The purpose of nail mending is to create a splint for a partially fractured nail plate (Fig. 32.12) or one longitudinal split extending the full length of the nail. The split is first bonded with cyanoacrylate glue, then the nail is painted with any clear nail varnish. A piece of wrap fabric is cut and shaped to fit over the nail surface. This is then embedded in varnish and several coats are applied; conversely, the fabric is applied directly over the crack and subsequently sealed to the nail with cyanoacrylate adhesive or no-light gel. In nail wrapping or "wraps," the free edge of the nail is covered with paper, silk, linen, or fiberglass and fixed to the plate with cyanoacrylate glue (Fig. 32.13). The activator for cyanoacrylate wraps is a catalyst and contains *N,N*-dimethyl-*P*-toluidine, in a solvent carrier. Methemoglobinemia with resultant cyanosis may follow its ingestion (22). It is typically 0.5% of the formulation, and HQ approximately 0.001%. The ethyl acetate and trichloroethane in these products do not promote curing, but are instead solvents.

Paper is not very effective, but silk wraps are sheer, very thin and works quite well. Linen is thicker and offers increased



(A)



(B)



(C)

**Figure 32.10** (A–C) Different stages for shaping the tips of nails.

strength, but inhibits cyanoacrylate penetration to the nail, thus lowering adhesion.

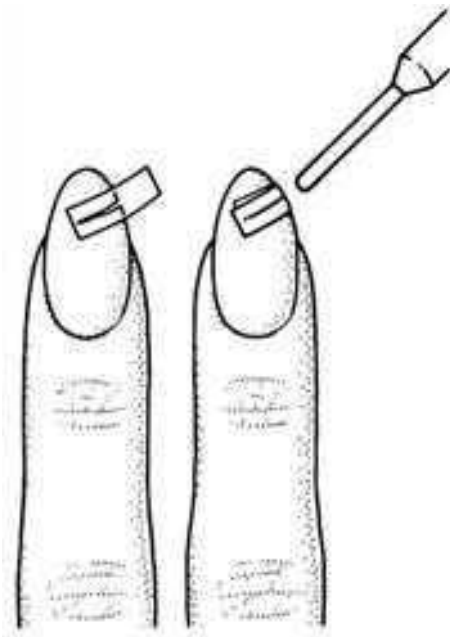
Fiberglass combines many benefits of both silk and linen and is the most universally used.

Most wrap systems consist of a few basic elements (42).

- Monomeric cyanoacrylate, polymerizing from moisture in the air or on the surface of the natural nail's surface to form



**Figure 32.11** Dystrophic nails with subungual hyperkeratosis due to preformed plastic nails. *Source:* Courtesy of P. Lazar.



**Figure 32.12** Nail mending.

the hard nail coating that is both the base and top coats of the nail wrap.

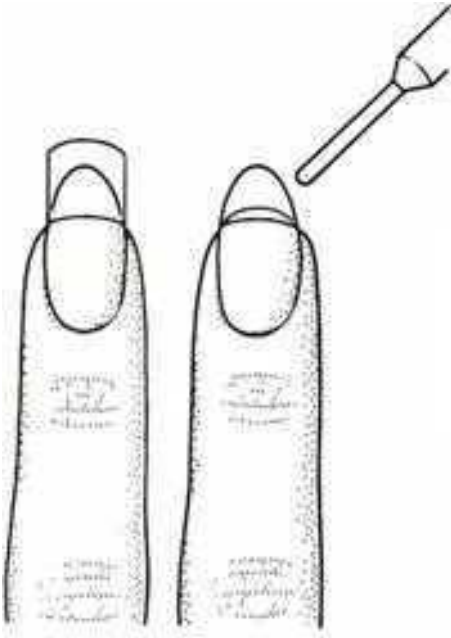
- A mesh material, for example, fiberglass or silk, is preferred.
- An activator or catalyst that cuts the hardening time to seconds.

See above for patch testing of patients sensitized to cyanoacrylate.

### NAIL HARDENERS AND TREATMENTS

There are two main types of product that make nail-hardening claims. In one group the products are modified nail polish, containing among their ingredients nylon fibers, (meth)acrylate





**Figure 32.13** Nail wrapping.

resin, and hydrolyzed proteins. They function either as a base coat for nail polish or as a stand-alone treatment. These products provide a protective coating, therefore the implied benefits come from the added strength and durability of the coating itself, rather than altering the physical properties of the nail plate. These products may also consist of polyesters and polyamides. These nail hardeners are essentially a modification of clear nail polish and the addition of nonfunctional ingredients for marketing purposes, that is, amino acids are hydrolyzed protein.

Like nail varnish and base coats, these are applied to the clean nail plate. Some are designed with a dual purpose and also function as a varnish base coat (17).

The second type of hardener chemically alters the structure of the nail. The U.S. FDA allows these products to contain products may contain up to 5% formalin [International Nomenclature of Cosmetic Ingredients (INCI) name: methylene glycol] and kits are required to contain a skin shield to protect the eponychium and side walls from exposure (43). It is important to note that until recently, the INCI dictionary required manufacturers to call formalin by an incorrect name, formaldehyde. Formaldehyde is an anhydrous gas that upon mixing with water reacts to form a methylene glycol and residual traces of formaldehyde in equilibrium. Most products never exceed 1.5% methylene glycol since at higher concentrations Both the nail plate and the surrounding tissue can quickly show signs of adverse changes. At these concentrations used products contain less than 12 ppm (0.0012%) free formaldehyde (44).

Companies selling these products generally disregard requirements for skin shields, so accidental skin exposure can occur.

Using a concentration of less than 0.2% methylene glycol seems to have little or to no positive benefits on the surface

hardness of the nail plate. Methylene glycol permanently alters the structure of the nail plate by cross-linking the keratin (45), which can quickly lead to embrittlement, since the cross-link density rises over time with continued regular use. Repeated use also allows a deeper migration into the plate, further affecting the bulk properties of the natural nail. Increased cross-link density increases the surface hardness of the nail plate, but it also lowers the flexibility while increasing the strength, resulting in an imbalance called brittleness (46). The property that people are unknowingly seeking is toughness. This occurs when there exists a favorable balance between strength and flexibility. Since the general public does not understand how or why these products work, the products are often applied to nails that are already overly brittle or rigid and therefore not suitable for further hardening. Even on nails that could benefit, these products are frequently misused. The preparations work so well on thin, weak nails that users see an almost instant improvement, which encourages repeated and frequently excessive use. After several weeks of success, the nails can eventually become overly hard and rigid. Continued use can cause splitting, cracking, and breaking, which unaware users can misinterpret. This will often cause them to continue to use these products with even greater frequency, leading to the problems associated with overexposure to this ingredient. Methylene glycol preparations may cause nail changes, including a bluish discoloration (Fig. 32.14), which may turn red, with intense throbbing (47). Resolving hemorrhages produce reddish-rust or yellow discoloration of the nail. Methylene glycol can also be responsible for paronychia, onycholysis (Fig. 32.15), subungual hyperkeratosis, and dryness of the fingertips, but nail shedding is uncommon. Pterygium inversum (Fig. 32.16) (48) has been observed, sometimes accompanied by severe pain necessitating a systemic corticosteroid (43).

Isolated onycholysis and ectopic contact dermatitis, even associated with hemorrhages of the lips in nail biters (49), have been reported. Airborne contact dermatitis of the face may also be seen. Formalin (1–2% in water) should be used for patch testing, but caution is necessary in interpreting the reactions because the agent also acts as an irritant. In recent years, a new nail-hardening ingredient has been introduced, which overcomes the objections related to formalin. The ingredient, dimethyl urea, is nonsensitizing, and 2% concentrations in a



**Figure 32.14** Acute formaldehyde reaction. *Source:* Courtesy of P. Lazar.



**Figure 32.15** Longstanding onycholysis due to formaldehyde.



**Figure 32.16** Pterygium inversum due to formaldehyde.

base coat preparation do not overcross-link the keratin. The higher molecular weight and relative increase in hydrophobicity prevent dimethyl urea from penetrating as deeply into the plate as methylene glycol.

This effectively limits the cross-linking action to the surface of the plate, thereby dramatically reducing the potential for overhardening and embrittlement. Further, the greater the cross-linking on the surface, the more restricted the dimethyl urea penetration will become, essentially creating a self-limiting cross-linking reaction while having the additional benefit of being nonsensitizing (50).

Other alternatives to formaldehyde hardeners are aluminum chloride (5% in water), tannin, and nail creams with a low water (30%) and high lipid content for minimizing nail fragility.

### Overall Risk

Recently, nine out of 819 patients showed a contact allergy to nail polish, while two persons reacted to artificial nails (51). The Cosmetic Ingredient Review has reviewed 24 artificial nail enhancement methacrylate monomers used to create the two-part systems and declared all to be "safe as used," while recog-

nizing that it was important to avoid direct skin contact with the monomers to minimize the potential for skin sensitization.

### REFERENCES

1. Barnett JM, Scher RK. Nail cosmetics. *Int J Dermatol* 1992; 31:675-681.
2. Fisher AA, Baran R. Occupational nail disorders with a reference to Koebner's phenomenon. *Am J Contact Dermatitis* 1992; 3:16-23.
3. Baran R, Schibli H. Permanent paresthesia to sculptured nails. A distressing problem. *Dermatol Clin* 1990; 8:138-41.
4. Engasser P. Cosmetics and contact dermatitis. *Dermatol Clin* 1991; 9:69-80.
5. Marks JC, Bishop ME, Willis WF. Allergic contact dermatitis to sculptured nails. *Arch Dermatol* 1979; 115:100.
6. Fisher AA. Permanent loss of fingernails from sensitization and reaction to acrylic in a preparation designed to make artificial nails. *J Dermatol Surg Oncol* 1980; 6:70-76.
7. Fisher AA, Baran R. Adverse reactions to acrylate sculptured nails with particular reference to prolonged paresthesia. *Am J Contact Dermatitis* 1991; 2:38-42.
8. Freeman S, Lee MS, Gudmundsen K. Adverse contact reactions to sculptured acrylic nails: 4 cases—reports and a literature review. *Contact Dermatitis* 1995; 33:381-385.
9. Fitzgerald DA, Enlish JSC. Widespread contact dermatitis from sculptured nails. *Contact Dermatitis* 1994; 30:118.
10. Koppula SV, Fellman JH, Storrs FJ. Screening allergens for acrylate dermatitis associated with artificial nails. *Am J Contact Dermatitis* 1995; 6:78-85.
11. Kanerva L, Lauerma A, Estlander T, et al. Occupational allergic contact dermatitis caused by photobonded sculptured nails and a review on (meth) acrylates in nail cosmetics. *Am J Contact Dermatitis* 1996; 7:1-9.
12. Lane CW, Kost LB. Sensitivity to artificial nails. *Arch Dermatol* 1956; 74:671-672.
13. Guin JD. Eyelid dermatitis from benzophenone used in nail enhancement. *Contact Dermatitis* 2000; 43:308-309.
14. Pillet J. The esthetic hand prosthesis. *Orthop Clin North Am* 1981; 12:961-969.
15. Beasley RW, de Beze G. Prosthetic substitution for fingernails. *Hand Clin* 1990; 6:105-112.
16. Goodwin P. Onycholysis due to acrylic nail applications. *Clin Exp Dermatol* 1976; 1:1991-1992.
17. Draelos ZK. *Cosmetics in Dermatology*. 2nd ed. New York: Churchill Livingstone, 1995.
18. Schubert HJ, Lindner K, Prater E. Kontaktallergie im Nagelstudio. *Z Hautkr* 1992; 67:1067-1069.
19. Turchen SG, Monaguerra AS, Whitney C. Severe cyanide poisoning from the ingestion of an acetonitrile containing cosmetic. *Am J Emerg Med* 1991; 9:264-267.
20. Caravati EM, Litovitz TL. Pediatric cyanide intoxication and death from an acetonitrile containing cosmetic. *J Am Med Assoc* 1988; 260:3470-3473.
21. Rainey PM, Roberts WL. Diagnosis and misdiagnosis of poisoning with cyanide precursor acetonitrile: nail polish remover or nail glue remover? *Am J Emerg Med* 1993; 11:104-108.
22. Potter JL, Krill CE Jr, Neal D, et al. Methemoglobinemia due to ingestion of *N,N*-dimethyl-*p*-toluidine, a component used in the fabrication of artificial finger nails. *Ann Emerg Med* 1988; 17:1098-1100.
23. Hornfeldt CS, Rab W. Nitroethane poisoning from an artificial remover. *J Toxicol Clin Toxicol* 1994; 32:321-324.
24. Halgmüller T, Hemmer W, Kusak I, et al. Loss of fingernails due to persisting allergic contact dermatitis in an artificial nail designer. *J Allergy Clin Immunol* 1995; 95:250.
25. Fischer AA. Adverse nail reactions and paresthesia from photobonded acrylate sculptured nails. *Cutis* 1990; 45:293-294.
26. Nethercott JR, Nosal R. Contact dermatitis in printing tradesmen. *Contact Dermatitis* 1986; 14:280-287.

27. Carmichael AJ, Foulds IS. Allergic contact dermatitis due to an amino-substituted diacrylate in a UV-cured lacquer. *Contact Dermatitis* 1993; 28:45–46.
28. Kanerva L, Estlander T, Jolanki R. Allergic contact dermatitis from dental composite resins due to aromatic epoxy acrylates and aliphatic acrylates. *Contact Dermatitis* 1989; 20:201–211.
29. Koefoed-Nielsen B, Pedersen B. Allergy caused by light-cured ear moulds. *Scand Audiol* 1993; 22:193–194.
30. Fisher AA. Adverse nail reactions and paraesthesia from photo-bonded acrylate 'sculptured nails.' *Cutis* 1990; 45:293–294.
31. Brooke RCC, Beck MH. A new source of allergic contact dermatitis from UV-cured acrylate adhesive. *Contact Dermatitis* 2002; 47: 179–180.
32. Hemmer W, Focke M, Wantke F, et al. Allergic contact dermatitis to artificial fingernails prepared from UV light-cured acrylates. *J Am Acad Dermatol* 1996; 35:377–380.
33. Pegum JS, Medhurst FA. Contact dermatitis from penetration of rubber gloves by acrylic monomer. *Br Med J* 1971; 2:141–143.
34. Pegum JS. Penetration of protective gloves by epoxy resin. *Contact Dermatitis* 1979; 5:281–283.
35. Calnan CD. Cyanoacrylate dermatitis. *Contact Dermatitis* 1979; 5:165–166.
36. Fitzgerald DA, Bhaggoe R, English JSC. Contact sensitivity to acyanoacrylate nail-adhesive with dermatitis at remote sites. *Contact Dermatitis* 1995; 32:175–176.
37. Shelley ED, Shelley WB. Nail dystrophy and Periungual dermatitis due to cyanoacrylate glue sensitivity. *J Am Acad Dermatol* 1988; 19:574–575.
38. Shelley ED, Shelley WB. Chronic dermatitis simulating small-plaque parapsoriasis due to cyanoacrylate adhesive used on fingernails. *J Am Med Assoc* 1984; 252:2455–2456.
39. Burrows D, Rycroft RJG. Contact dermatitis from PTBP and tricreyl ethyl phthalate in a plastic resin. *Contact Dermatitis* 1981; 7:336–337.
40. Pigatto PD, Giacchetti A, Altomare GF. Unusual sensitization to cyanoacrylate ester. *Contact Dermatitis* 1986; 14:193.
41. Opinion of the Scientific Committee on Cosmetic Products and Nonfood Products Intended for Consumers (SCNFP), The Use of Benzoyl Peroxide (BPO), Hydroquinone (HQ), Hydroquinone Methylene (MeHQ) in Artificial Nail Systems, SCCNFP/0486/01/final, June 2002.
42. Hill S. The fiberglass option: natural look, supernatural strength. *Nails Magazine* 1990; Aug:44–52.
43. Norton LA. Common and uncommon reactions to formaldehyde-containing nail hardeners. *Semin Dermatol* 1991; 10:29–33.
44. Winkelman JGM, Voorwinde OK, Ottens M, et al. Kinetics and chemical equilibrium of the hydration of formaldehyde. *Chem Engin Sci* 2002; 57:4067.
45. Kieran JA. Formaldehyde, formalin, paraformaldehyde and glutaraldehyde: What are they and what do they do? *Microsc Today* 2000; 8:8–12.
46. Schoon D. *Milady's Nail Structure and Product Chemistry*. 2nd ed. Albany: Thomson/Delmar Publishing, 2005:205–206.
47. Lazar P. Reactions to nail hardeners. *Arch Dermatol* 1966; 94: 446–448.
48. Daly BM, Johnson M. Pterygium inversum inguis due to nail fortifier. *Contact Dermatitis* 1986; 15:256–257.
49. Hülldin DH. Hemorrhages of the lips secondary to nail hardeners. *Cutis* 1968; 4:708.
50. Caletto J, Patel A. Composition for application to keratinous substrate and a method for strengthening such substrates. Revlon Consumer Products Corporation, U.S. patent 5,993,833, November 30, 1999.
51. Kohl L, Blondeel A, Song M. Allergic contact dermatitis from cosmetics. *Dermatology* 2002; 204:334–337.

## Hand and body lotions

F. Anthony Simion and David C. Story

### INTRODUCTION

Skin, the largest organ of the body, plays a critical role as the interface between the human body and the environment. Originally it was thought mainly to have a passive role, being a physical barrier to environmental threats such as low humidity, biological pathogens, UV radiation, physical trauma and environmental pollutants. It has always been recognized as playing a vital role as a sensory organ alerting us to the presence and nature of objects surrounding us, extremes of temperature and noxious chemicals. More recently its active interactions with the environment have become more appreciated. It is physiologically active: the immunological response involving keratinocytes and Langerhans cells as well as the T- and B-lymphocytes. Melanin in the skin protects it from UV damage. Upon exposure to strong light, melanin can be redistributed to the keratinocytes protecting the cells of the lower epidermis. The skin has significant levels of enzymes such as cytochrome P<sub>450</sub> that can metabolize xenobiotics. However, it is most effective as a barrier if it is intact. Hand and body lotions play a vital role in helping to maintain the integrity and plasticity of the stratum corneum (SC) in the face of many outside threats. Furthermore it provides a crucial benefit to consumers, your patients, in improving the feel of their skin and eliminating the negative sensations of dryness and itching associated with dry skin.

Dermatologists continue to see many patients suffering from dryness and itching often associated with visible scaling and flaking of their skin. Even more consumers treat themselves without medical intervention. There are many causes for the increasing prevalence of dry skin. Shifting demographics, specifically the aging population in combination with increased usage of low humidity central heating and air conditioning systems has significantly contributed to the increase in dry skin complaints. In addition, skin is exposed to household detergents and personal cleansers, which can quickly damage the SC proteins, extract small hygroscopic molecules and deplete or rearrange the bilayer structure of key intercellular lipids. This causes a dramatic decrease in the skin's ability to act as a barrier. Detergent induced dryness and primary irritation has made dermatitis one of the most common forms of occupational disease in developed countries. Health care workers, hairdressers, nurses and food handlers are especially at risk (1,2).

During the last 100 years hand and body moisturizers have been designed to provide relief to dry skin sufferers by increasing the skin's softness and smoothness (plasticity) while eliminating skin scaling. There are several mechanisms to achieve this. They include increasing the skin's water content by forming an occlusive barrier, by binding more water more

effectively (humectancy), and by supplementing the water with other plasticizing materials. Indeed individual moisturizing ingredients may deliver benefits to the skin by several mechanisms. For instance, glycerin works as a humectant, a fluidizer of the lipid bilayer and an activator of SC enzymes. It also is a skin softening agent (emollient). Today's moisturizers are far superior to those of the past. This is due to new materials that are capable of mimicking the skin's biological moisture holding mechanisms and the ability to deliver these materials effectively to the skin. Ingredients such as ceramide analogs, provitamins, and essential fatty acids, have been successfully incorporated into hand and body lotions. When moisturizers are used regularly, they help to mitigate dry skin. Furthermore, advances in formulating have produced esthetically superior products that consumers enjoy using, yet maintain their efficacy. The leading hand and body lotion brands in the United States are shown in Table 33.1.

A second role for hand and body moisturizers is as a vehicle for active ingredients including OTC drug actives such as sunscreens, and cosmetic ingredients such as antioxidants, antiirritants,  $\alpha$ -hydroxy acids (AHAs), and a multitude of botanical extracts. As a result of increased awareness regarding the effects of the sun, recent marketplace trends show an increase in the number of hand (and facial) moisturizers that have the ability to block UVA and UVB exposure. Hand and body moisturizers serve as an effective and convenient vehicle for the delivery and application of sunscreen ingredients. Importantly, esthetically optimized SPF moisturizers are now available, which provide consumers with much preferred tactile benefits such as a nonsticky, nongreasy, and nonoily skin feeling; attributes not traditionally found in sunscreen products.

The efficacy and esthetics of hand and body lotions depends on several factors. Gross chemical composition is not the only factor that effects both efficacy and skin feel. Most lotions are emulsions, heterogeneous mixtures of oil and water-soluble materials. How ingredients are distributed between the oil and aqueous phases plays a significant role in how they are delivered to and partition into the skin to have their moisturizing effects, and the feel of the skin during and after application. To account for these factors, this chapter will discuss the ingredients used in lotions separately from emulsion structure. Assessing the safety and efficacy of lotions will also be discussed.

In conclusion, although many skin characteristics are genetically determined, the environment also has significant effects. These negative effects can be ameliorated by regular use of cosmetic moisturizers. The regular use of moisturizers, a healthy diet, protection from the sun and regular exercise will contribute to significantly healthier, younger looking skin.

**Table 33.1** Leading Hand and Body Lotions in the United States

Brand <sup>a</sup>	Manufacturer	Emulsion type	Key moisturizing ingredients
Jergens	Kao Brands Company Cincinnati, Ohio	Oil in water	Glycerin, petrolatum mineral oil Nonionic emulsifiers
Vaseline Intensive Care	Chesebrough-Ponds (Unilever) Trumbull, Connecticut	Oil in water	Glycerin, sunflower seed oil, C11-13 paraffin, petrolatum TEA stearate
Lubriderm	Johnson & Johnson Los Angeles, California	Oil in water	Mineral oil, petrolatum, lanolin, sorbitol, glycerin
Eucerin	Beiersdorf Norwalk, Connecticut	Water in oil	Petrolatum, mineral oil, lanolin alcohol, hydrogenated castor oil
Curel	Kao Brands Company Cincinnati, Ohio	Oil in water	Glycerin Cationic polymers Petrolatum
Neutrogena	Neutrogena Corporation (Johnson & Johnson) Los Angeles, California	Oil in water	Glycerin Cationic polymers Petrolatum
Sauve	Unilever Chicago, Illinois	Oil in water	Glycerin, mineral oil
Gold Bond	Sanofi Aventis	Oil In water	Glycerin Cationic polymers Petrolatum

<sup>a</sup>Several brands have many variants—the “key ingredients” are a composite between variants.

## INGREDIENTS FOR HAND AND BODY LOTIONS

### Overview

As anyone who has looked at the ingredient statement for a typical hand and body lotion can attest, the number and variety of ingredients used in these products can be somewhat intimidating. Consequently, it is clear that a review of all of these ingredients is beyond the scope of this chapter. However, this chapter will attempt to cover the major categories of ingredients, organized according to their function in the product.

Before we begin the review of specific ingredients, a few general comments about ingredient disclosure may be helpful. In the United States, manufacturers of cosmetic products are required to provide a complete disclosure of the ingredients used in their products. This requirement was established for the purpose of allowing consumers to monitor ingredients and to make an informed purchase. Package labeling guidelines require listing ingredients in descending order of weight percent. One exception is for ingredients used at levels of 1% or less. Such minor ingredients can be listed in any order. Since many of the ingredients used in hand and body lotions are complex or ill-defined chemical entities, a standard nomenclature has been developed by the Personal Care Products Council (PCPC; formerly the Cosmetics, Toiletries, and Fragrance Association). Under the PCPC guidelines, manufacturers are obliged to use the assigned “International Cosmetic Ingredient” (INCI) name for all ingredients used in their products. Information about these ingredients, manufacturers and chemical structures are compiled in the PCPC International Cosmetic Ingredient Dictionary, which is a highly recommended resource for cosmetic formulators.

### Ingredient Classes

#### Water

This ingredient can be found at the beginning of nearly all ingredient statements for hand and body lotions since it typically makes up 70% or more of the formula. Water has two important functions in a hand and body lotion. First, it is the vehicle by which many other ingredients are delivered to the skin. Second, water can be viewed as an active ingredient in the sense that it hydrates the skin for a short time, usually less than 15 minutes, before evaporating. Although the PCPC does not recognize the use of any particular type of water (such as “purified water”) for the purpose of ingredient labeling, most manufacturers do use treated water. They use water that is softened or deionized (demineralized) water in their products to avoid any interactions between calcium, magnesium, and

iron ions and other components in the formula. It is also customary in the industry to process the deionized water to remove problematic microorganisms.

Since the water concentration is transient after application and quickly evaporates, materials that are minor components of the formula become concentrated on the skin. This fact is often forgotten when determining the benefits and risks of these minor ingredients.

#### Emollients

An emollient can be defined as an ingredient that softens the SC. Emollients used in hand and body lotions are frequently oily materials that help plasticize dry skin either by direct interaction with the SC or by providing an occlusive barrier that traps water from the under laying skin strata. However, glycerin has a similar skin softening effect. The plasticized SC is exhibits more flexibility and a surface that is more uniform, which consumers perceive as smooth and soft.

Historically, lanolin was one of the first commercial emollients used widely by the industry. It was a prominent ingredient in apothecaries from the 1920s to the early 1960s. Pharmacists used lanolin as a base for compounding ointments. It has the unique ability to adsorb up to 30% of its weight in water. It is a refined portion (deodorized and bleached) of raw wool wax. Wool wax is the fatty, waxy residue separated from the washings of sheep’s wool, which yields a complex mixture of semisolid oils, fats and waxes. As an emollient, lanolin provides a strong occlusive effect when applied to skin and may also directly plasticize the SC. Lanolin, its constituents and derivatives are still used in some hand and body lotions, but have largely been replaced by other emollients because of its reported sensitization potential. These adverse reactions may be due to the presence of low levels of alkane- $\alpha,\beta$ -diols and alkane- $\alpha,\omega$ -diols (3). Pesticide residues were an issue for lanolin, and the U.S. Pharmacopoeia monograph specified limits for organic pesticides (4). This change in the monograph has forced manufacturers to commercialize a higher purity of an old emollient.

Two of most common emollients used today are mineral oil and petrolatum, which are hydrocarbon based materials derived from petroleum. Petrolatum, in particular, resembles lanolin in its physical characteristics and its occlusive effect on the skin. In addition to forming an occlusive barrier, Ghadially et al. (5) showed that petrolatum penetrates into the intercellular lipids of the SC. Kligman (6) reported that petrolatum was very effective at reducing observable skin dryness and preventing its reappearance. Compositionally, the only difference

between mineral oil and petrolatum is the number of carbons in the hydrocarbon chains with mineral oil having fewer carbons. Mineral oil is less occlusive, but has better spreading properties and is generally believed to have a less greasy feel on the skin compared with petrolatum.

Silicones are a class of synthetic polymers that are also widely used in hand and body lotions. Most silicones are used for their good spreading and detackifying properties as well as their emolliency. They also form good barriers to environmental agents and often are the principle ingredient in skin protective products. Common examples are dimethicone and cyclopentasiloxane.

Another class of emollients is triglycerides, which are derived from animal fats or vegetable oils. These oils are usually named according to the original source such as sunflower seed oil. Triglycerides (oils) contain approximately 5% free fatty acids. Many triglycerides contain essential fatty acids. Essential fatty acids are unsaturated fatty acids that cannot be synthesized by the body yet are required for maintaining the SC barrier function. Experiments have shown that when EFAs are withheld from rats' diet, their skin becomes scaly and water barrier function is compromised (7). Healthy skin can be restored by topical application of triglycerides that are rich in EFAs. Similar results were observed in human patients whose lipid intake had been reduced because of stomach surgery (8).

Processing of triglycerides is a major industry. Triglycerides as neutral fats and oils are hydrolyzed to form fatty acids, fatty alcohols, and a predominant raw material in the manufacturing of soap. The hydrolysis produces monoglycerides and diglycerides, which are also used in emulsion products as a secondary agent for stabilizing the suspension.

The use of unsaturated triglycerides in a hand and body lotion can create problems due to the susceptibility of these oils to oxidation, producing discoloration and off odors (rancidity) over time. To prevent this oxidation, stabilizers such as antioxidants, for example, tocopherol (vitamin E), BHA, or BHT, chelators, for example, EDTA salts, are often added to the formula.

Triglycerides may be processed to provide a large variety of other emollient ingredients. Glycerides are used not only for

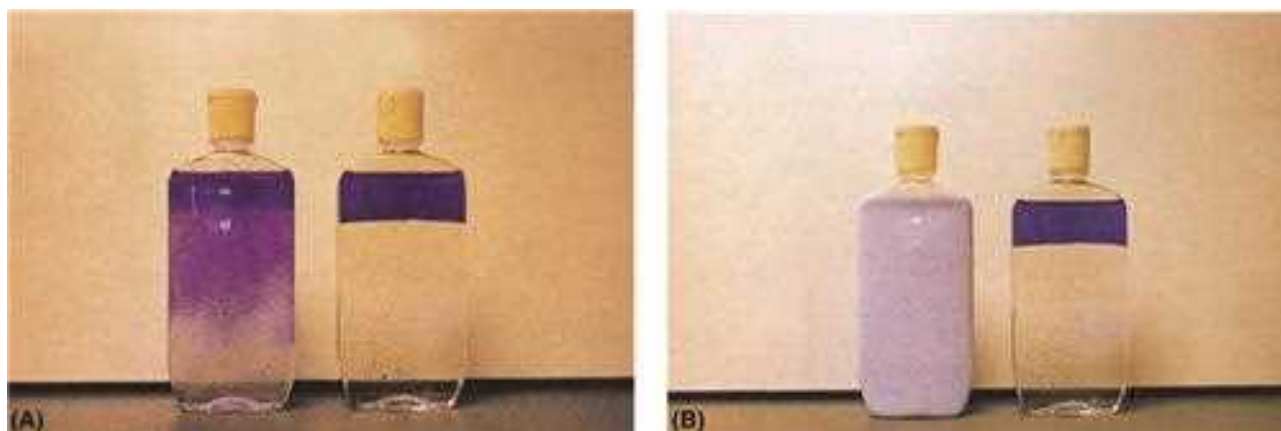
emolliency, but also for their ability to stabilize the lotion by emulsification (see section "Physical Structure of Hand and Body Lotions"). Examples of glycerides are glyceryl stearate (monoglyceride), glyceryl dilaurate (diglyceride), and palm oil glyceride (mixed glycerides). Fatty acids are also processed to produce fatty esters. Numerous types of fatty esters are used in hand and body lotions. Some common examples are isopropyl myristate, isopropyl palmitate, octyl hydroxystearate, and cetyl palmitate.

#### Humectants

Humectants are water-soluble organic compounds, typically polyhydric alcohols, which have an affinity for water. The most common humectant is glycerin, but others include sorbitol, propylene glycol, dipropylene glycol, and butylene glycol. Once it was believed that these ingredients helped to moisturize the skin simply by binding additional water in the SC, thus plasticizing the SC and reducing the rate of evaporation. However, within the last 20 years, two additional mechanisms by which glycerin may moisturize have been proposed. Froebe, Matti and their colleagues showed that glycerin at low humidity can prevent the conversion of liquid crystals in the intercellular lipids to a solid, rigid crystal within the SC (9,10). The solid crystal is more readily removed by environmental factors, for example, cleansing, and provides less resistance to water loss. This effect may be responsible for the improvement in barrier function observed when glycerin (and possibly other humectants) is applied to the skin. Rawlings et al. showed that glycerin is able to promote normal desquamation by enhancing the activity of the proteases that degrade desmosomes (11). It is likely that all three mechanisms occur in the SC simultaneously.

#### Emulsifiers

Classically, these are surface-active ingredients, which are used to promote temporary mixing, and suspension of the discontinuous phase (often oils) into the continuous phase (usually water). This will significantly slow the rate at which the two phases separate (Fig. 33.1). Conventional emulsifiers are often classified on the inherent charge associated with the surface-active ingredient. The classes are anionic (negative charge), cationic (positive charge) and nonionic (no charge/neutral).



**Figure 33.1** (A) Emulsifiers reduce the rate at which the oil and aqueous phases separate. The left-hand bottle contains an emulsifier with the oil and aqueous phases, whereas the right-hand bottle contains no emulsifier. After mixing the system on the left separates more slowly. (B) Emulsions are opaque systems (*left*) compared with an unemulsified two-phase oil/water system (*right*).

The anionic emulsifiers were widely used for many commercial moisturizers. In most early oil-in-water (o/w) emulsions utilized a soap (anionic) formed in situ by neutralization of a fatty acid with a metallic hydroxide or an amine. The common material used as a soap emulsifier is neutralized stearic acid. The anionic emulsifiers tend to be more irritating and their level of use should be balanced between having a product that is stable yet nonirritating to skin.

Nonionic emulsifiers are probably the most commonly form used today. They produce stable and nonirritating emulsions or suspensions. The cosmetic formulator again will use these materials judiciously to maintain the desired properties without adding excess amounts of the surface-active agents. Since these emulsifiers are surfactants, they have the potential to be irritating to the skin and any excess adds more cost to the formula. Common nonionic emulsifiers are ethoxylated or propoxylated fatty alcohols, such as cetareth-20 or steareth-2.

The third class, cationic emulsifiers has become more widely used for moisturizers that are more therapeutic or long lasting. The cationic products are substantive to the SC. The SC surface is negatively charged from the fatty acids and basic amino acid residues and therefore a positively charged droplet is attracted to the skin. These types of emulsions resist wash-off with water and possess different esthetics. Common cationic emulsifiers are the long-chained fatty alcohols bonded to quaternary nitrogen, such as distearyldimonium chloride or behen-trimonium chloride.

Recent advances in polymer science have now created a quasi fourth class of emulsifiers. The new emulsifier is based on a hydrophobically modified polymer poly (2-acrylamido-2-methylpropanesulfonate), which is also known as AMPS. It is an amphipathic and when a nonionic emulsifier is added the emulsion yields a stable o/w emulsion. Most suppliers of polymers for personal care products now have variations of the AMPS copolymers within their product line (12).

#### *Water-Soluble Polymers (Thickeners and Conditioners)*

Common additives to emulsion products are water-soluble polymers. The polymers can be synthetic or natural. The most common class is the acrylates. These polymers are synthetic with an anionic charge. Some common examples are acrylates/C10-30 alkyl acrylates cross-polymer and carbomers. Acrylic acid polymers often require neutralization with a base to realize their benefit in emulsion products. The base neutralizes the pendant acid chains allowing them to “unfold” creating spoke-like projections, which form an intricate network. The network builds viscosity and resists separation of the emulsion phases.

There are many water-soluble polymers that are derivatives of cellulose. The cellulosic polymers possess an anionic or nonionic charge and numerous grades with various properties are commercially available. The commercial grades vary in molecular weight, ether linkages and electrolyte tolerance. Examples of common cellulose are: sodium carboxymethyl cellulose, hydroxypropyl methylcellulose, and hydroxyethylcellulose.

There are also cationic water-soluble polymers both synthetic and natural. They are derivatives of cellulose, polysaccharides and modified acrylic acids. These polymers are usually restricted to cationic and nonionic emulsions because of the inherent instability that arises when added to anionic systems. Polyquaternium-10, chitosan and derivatized guar gum are three such polymers frequently found in hand and body lotions.

The water-soluble polymers enhance emulsion stability by preventing the small, suspended droplets from fusing

together. The polymer network sterically restricts the movement of the dispersed phase and enhances the formula's apparent viscosity.

#### *Minor Components*

*Preservatives and fragrances.* Although they make up a very small percentage of the total formula, these ingredients are of concern to dermatologists as they cause many of the sensitization reactions from lotions that require medical attention (13). Indeed the mixture of fragrances used in patch testing has one of the highest incidence rates observed for cosmetic ingredients. Consumers' recognition of the association between fragrance and adverse reactions has prompted many manufacturers to develop unscented products. Their increasing popularity has led some manufacturers to include various botanical extracts, which technically are not fragrances, yet still include many of the same chemicals found in certain fragrances. The European Union requires common fragrance ingredients that are believed to be allergens to be declared in the ingredient statement when exceeding minimum thresholds established. This is 10 ppm for leave-on and 25 ppm for wash-off products.

Preservatives are included in hand and body lotions to prevent the growth of microorganisms, specifically bacteria, mold and yeast. These are necessary for several reasons. First, most hand and body lotions contain a high percentage of water, which makes them a good growth media for these microorganisms. Inadvertent contamination by consumers during use can lead to rapid bacterial growth and spoilage of the product. Further, if the growth of opportunistic pathogenic bacteria such as pseudomonas is not prevented, blindness could result when applied to compromised skin or near the eye.

Given the need to prevent growth of microorganisms in their products, manufacturers use a variety of biocide and biostatic agents in sufficient concentrations to provide a product that does not allow for active growth. In other words, the preservative system is designed and tested to withstand multiple contaminations so that any microorganisms introduced into the product are either killed or prevented from actively multiplying. These agents are most often used in various combinations to provide effective preservation against a broad spectrum of bacteria and mold.

The preservatives are also an ingredient class, which receives a significant amount of consumer concern. In today's environment misinformation can often be represented as scientific data. Unfortunately, the majority of consumers do not have the training to scrutinize data and determine its scientific validity but they do understand fear and wish to avoid harm to themselves and their loved ones. This has been the situation with the common biocides in personal care products and especially parabens. With consumer access to the internet, many materials can be erroneously classified as dangerous. Our challenge as an industry is to counter and correct consumer misperceptions. To help in this process the PCPC has launched a website ([www.cosmeticsinfo.org](http://www.cosmeticsinfo.org)) that provides accurate information on the safety of cosmetic ingredients.

The following is a partial listing of some of the common biocides used in hand and body lotions—preservatives that work by releasing formaldehyde (formaldehyde donors):

- DMDM hydantoin
- Diazolidinyl urea
- Imidazolidinyl urea
- Quaternium-15



**Figure 33.2** Both emulsion types are intensely opaque with differing degrees of reflectance. Equal amounts of water-soluble dye and base were used to create the image. The oil-in-water (o/w) emulsion has a continuous phase of water and the dye imparts the color to this phase (darker intensity). The water-in-oil (w/o) emulsion is less intense in color since color is restricted to the discontinuous or suspended phase.

Preservatives that work by mechanisms other than releasing formaldehyde are as follows:

- Parabens (esters of *P*-hydroxybenzoic acid)—the most common are methyl paraben and propyl paraben, but other esters are also used
- Methyl-dibromo-glutaronitrile
- Benzyl alcohol
- Methylchloroisothiazolinone/methylisothiazolinone (MCI/MI)
- Ethanol
- Phenoxyethanol
- Iodopropynyl butylcarbamate

*Skin care additives.* Many lotions have cosmetic materials added at low levels for marketing purposes, that is, to persuade consumers of additional benefits from these ingredients and to buy the product. In these cases the moisturization benefits that consumers require are delivered by the overall product. However, in the last few years, additives have been identified that improve the appearance and feel of the skin over the vehicle alone. These include AHAs, retinol and ceramide analogs (14,15). Imokawa et al. showed that ceramide analogs increase the water holding capacity and barrier function especially of damaged skin. Stiller et al. showed that 8% lactic or glycolic acids reduce the signs of photodamage compared with a vehicle after 22 weeks of treatment. However, these levels of AHAs have also been shown to increase the skin's sensitivity of the sun (16).

## Physical Structure of Hand and Body Lotions

### Overview

Most hand and body lotions are emulsions. A simple definition for an emulsion is a thermodynamically reversible suspension. The insoluble ingredients are dispersed in a vehicle (usually water). The vehicle is the continuous phase and the suspended droplet or particle is the discontinuous phase. The particle size of the suspended droplet in most emulsions occurs in the range of 10 to 20  $\mu\text{m}$ , which are not visible with the human eye but do

effectively scatter light. This gives these products their characteristic opaque, white appearance (Fig. 33.2).

Hand and body lotions can be further characterized as being one of two emulsion types. The first type of emulsion, which is by far the most common, is referred to as an o/w emulsion, often abbreviated "o/w." This type of emulsion consists of tiny droplets of oils and/or waxes dispersed in water (the continuous phase). The second type of emulsion takes the opposite form: droplets of water dispersed in a mixture of oils. This is referred to as a water-in-oil ("w/o") emulsion. In addition to the binary (o/w or w/o) emulsions, there are more complicated tertiary emulsions, which will be discussed briefly at the end of this section.

*Oil-in-water emulsions.* This is the typical form of emulsion used in hand and body lotions. The water-insoluble ingredients (oils) are the emollients that are typically used in the range of 5% to 25% of the total formula, and the fragrance. The water-insoluble ingredients are dispersed into the aqueous phase, that is, water with all of the aqueous soluble materials, for example, humectants.

In an o/w emulsion, the emulsifiers have two important functions. First, the emulsifiers act at the interface between the oil and water phases to reduce the energy required to overcome the inherent surface tension of water. By reducing the required energy, a fine dispersion of the oil ingredients into the water is easily obtained. The second function of the emulsifiers is to stabilize the emulsion, retarding the natural tendency of the oils to separate from the water phase of the formula. Emulsifiers stabilize the formula by forming a film ("coating") around each oil droplet and preventing it from coalescing with other oil droplets and thereby growing in size. Preventing growth in droplet size is critical for stabilizing an emulsion. The appearance of large droplets would compromise the lotion's smooth texture and appearance.

In terms of esthetics, o/w hand and body lotions can range from very "light" (low oil content) to heavy (high oil content). The skin feel of the product during rub in and after drying is affected not only by the amount of oil, but also the types of the emollient oils used in the formula. For example, if the emollient oil mixture is composed mainly of mineral oil, the



lotion will generally provide an “oily” feel on the skin, while the use of emollients like lanolin or petrolatum gives a heavier “greasy” skin feel.

o/w emulsions may be better able to deliver water-soluble materials to the skin. Sah et al. showed enhanced delivery of lactic acid to the skin from an o/w emulsion compared with a w/o emulsion that had a similar composition (17). A tertiary w/o/w emulsion (see below) showed an intermediate rate of delivery.

*Water-in-oil emulsions.* This type of emulsion is much less common than the o/w type for several reasons. One key reason is esthetics. To have enough emollient oil to surround the water, a relatively large percentage of oil is required, usually in excess of 25%. Thus it is very difficult to formulate a w/o hand and body lotion with a light skin feel. Another reason w/o emulsions are not common is they are more expensive to manufacture than o/w emulsions. Oils are more expensive than water and increasing the oil content will increase formula cost. Additionally, to produce and stabilize w/o emulsions, special emulsifiers are necessary, which generally cost more than o/w emulsifiers.

Recent advances in silicone technology have created a new type of w/o emulsion that has a higher percentage of water. The silicone emulsifiers facilitate the formation of a monolayer of oil surrounding the water droplet. This allows the oil percentage in the formula to be in the range of 10% to 15%, which is equivalent to a conventional o/w emulsion. The benefit of the silicone based o/w emulsion is that when it is applied to the skin, it is resistant to wash-off. This type of technology is ideal for long-lasting sunscreen products particularly when swimming.

For commercial hand and body lotions, simple test will often determine if the emulsion is o/w or w/o. If the lotion rinses away easily from the skin in running water, it is probably an o/w. If the product will not rinse away and leaves an oily shine on the skin, it is probably a w/o. In the laboratory an electrical bridge can be used to differentiate the two types of lotion. O/w emulsions with their continuous aqueous phase conduct electricity well. In contrast w/o emulsions, which have a continuous oil phase do not conduct electricity.

*Complex emulsions.* In addition to the binary emulsion systems already discussed, there are more complicated emulsions, which have been developed for use in personal care products. One such system is the w/o/w emulsion where a water phase is first dispersed and stabilized into an oil phase, and this w/o emulsion is in turn dispersed into a second water phase. The purpose of this elaborate emulsion structure is to protect water-soluble ingredients by sequestering them inside the oil phase where they would not come into contact with other ingredients in the second water phase that may degrade them. Examples of ingredients, which might require such protection, would be biological materials such as enzymes.

## Assessing Moisturizer Efficacy

### Overview

The primary use of hand and body moisturizers is to alleviate skin dryness and irritation and prevent their return. Measuring these effects, both from a consumer and an objective perspective are primary objectives for assessing a moisturizer's efficacy. Clinical methods with controlled application have been developed that assess dry skin and irritation or their absence by visual scoring by a trained observer, using biophysical measurements of the skin and by panelists' self-assessments.

However, clinical efficacy alone is not sufficient to make a product commercially successful. To appeal to consumers, the lotion must be both efficacious and esthetically pleasing, that is, pleasantly scented (or unscented) and have acceptable tactile characteristics during and immediately after application.

### Clinical evaluation of moisturizer efficacy

**Alleviating dry skin** Clinical evaluation is an important component in the measurement of moisturizer efficacy. The visual assessment of skin dryness is a direct link to the perceivable benefits of “moisturization” that consumers readily recognize. Signs of dry skin include flaking and scaling, fine dry lines, rough texture, ashiness, and skin cracking. Figure 33.3 shows the different levels of skin dryness observed in clinical studies. In many studies, visual assessments are supplemented with instrumental measures of skin hydration, surface topography, or elasticity. These instrumental measurements are more easily standardized than observer assessments and each will provide an objective assessment of a particular cosmetic benefit.

There are a variety of methods used to assess the ability of moisturizers to alleviate dry skin. These include the single application test and the regression test developed by Kligman and later modified by others (6). Typically, these studies start with dry skin, frequently on the legs, and then the skin is treated. In the single-application test, the condition of the skin can be reassessed as little as 2 hours after product application and at subsequent time points, some even beyond 24 hours. It is important to include time points of two hours or greater post application, as many lotions contain water that rapidly evaporates. This is usually completed within two hours. In these studies, moisturization is frequently assessed by electrical measurements or by observer scoring.

The regression test was developed by Kligman to assess the effects of both products and their constituents on dry skin. Test material (2 mg/cm<sup>2</sup>) is applied to the lower legs of 12 to 30 female panelists twice daily for up to three weeks (Fig. 33.4). The visual dryness was assessed prior to treatment (baseline) and at the end of each week. Panelists started with dry skin and the improvement in dryness from baseline was the measure of moisturization efficacy, or the relief of dryness.

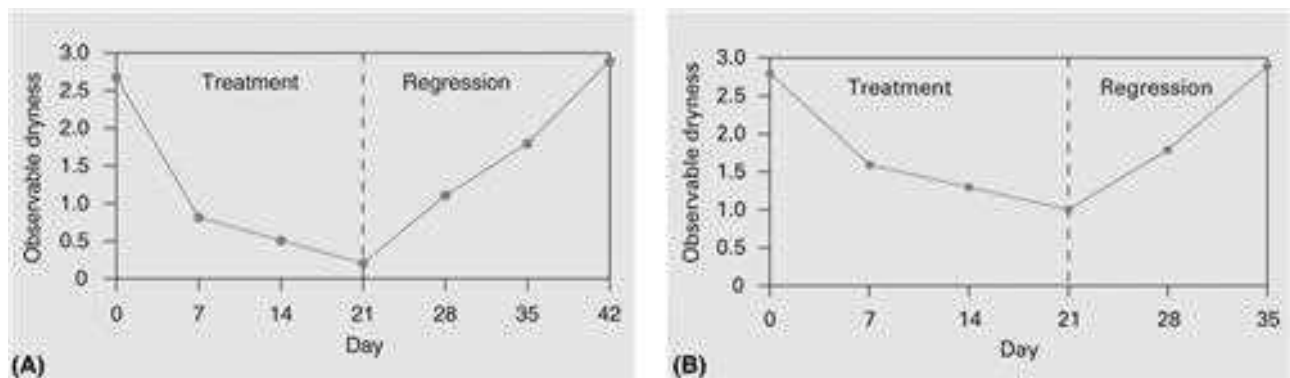
Using the regression test, Kligman showed that hydrophobic oils, such as mineral oil or olive oil, alone had little ability to alleviate dry skin. The efficacy of these oils was enhanced when they were formulated with hydrophilic materials into cold creams. Kligman's data suggested that the moisturizers composition could have a greater influence on its efficacy than the number of applications (dosage). He demonstrated a large range in the ability of ingredients to alleviate dryness, but increasing the dosage had limited effects especially beyond four applications a day.

The Kligman regression protocol has been modified by several groups to meet different assessment needs. Boisitis et al. (1989) (18) applied more rigorous conditions to reduce the experimental variability and increase test sensitivity. The most notable modifications include the following:

1. Conducting the test only if the temperature and humidity were below 45°F and 40%, respectively
2. Throughout the study, washing test sites with ivory soap<sup>®</sup> prior to lotion application to increase the propensity of the skin to dry out
3. Requiring leg shaving no more than two times a week and no later than 30 hours before an observation



**Figure 33.3** Different levels of skin dryness observed in a moisturization study, utilizing a 0 to 4 scoring scale.



**Figure 33.4** Petrolatum is more effective than lanolin in alleviating dry skin and preventing its return. (A) Effect of petrolatum on dry skin. (B) Effect of lanolin on dry skin. The Kligman regression test was used: test material is applied to the lower leg daily for three weeks; after treatment stops, the legs are followed until the skin's condition regresses to its original level of dryness. Regression takes longer for petrolatum than for lanolin. *Source:* From Ref. 6.

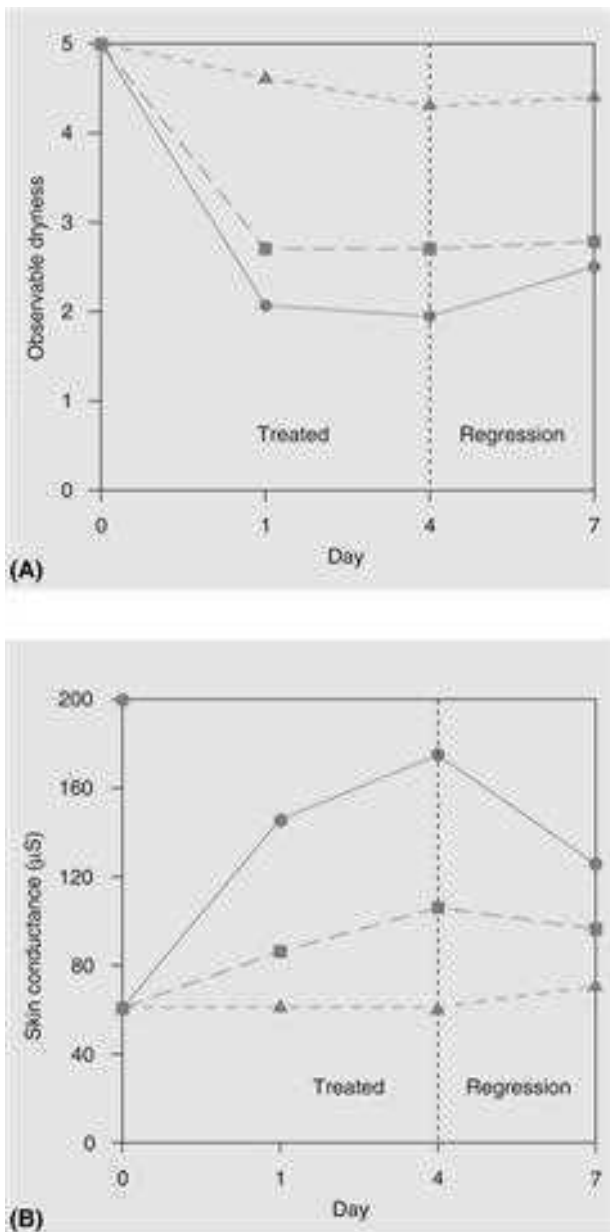
Biosits et al. claimed the refined methodology allows for better differentiation between products.

Another modification has been dubbed the miniregression. Prall et al. (19) reported a regression study conducted using a four-day treatment followed by a six-day regression phase.

The protocol was similar to Kligman's method as the applications were conducted twice daily with a dose of approximately 2 mg/cm<sup>2</sup>. Product efficacy differences were determined during regression in the following descending order of

efficacy: 5% lactic acid lotion > o/w lotion > placebo. Grove et al. (20) utilized the same miniregression time frame to examine the efficacy of marketed moisturizers. Clear differences between each of the two products and between the treated sites and the untreated site were observed (Fig. 33.5). In this study skin conductance was used to confirm the observer scored dryness.

In a similar study of moisturizers containing glycerin, Appa et al. (21) utilized a seven-day treatment period followed by a seven-day regression. These investigators demonstrated



**Figure 33.5** Effect of two lotions on skin dryness as assessed by a miniregression test. (A) Effect of products on observable dryness. (B) Effect of products on skin conductance: product A, product B, untreated. Source: From Ref. 20.

that the moisturizer efficacy increased with the concentration of glycerin. A plateau was reached with a 25% glycerin lotion being similar in efficacy to a 40% glycerin cream. These results could also relate to the ability of the products to deliver glycerin into the skin, or to the effect of ancillary ingredients.

A third adaptation of the regression test utilizes the lower arms, either the volar or dorsal aspect. Prall et al. (19) used a miniregression design to compare the performance of two lotions on the legs using a controlled lotion dosage with performance on the outer aspect of the arms using ad libitum dosage. They concluded that either method accurately predicted

the directional efficacy of the lotions. Grove (20) originally used the miniregression methodology to examine lotion efficacy on the volar forearm using the instrumental method of skin conductance to evaluate performance.

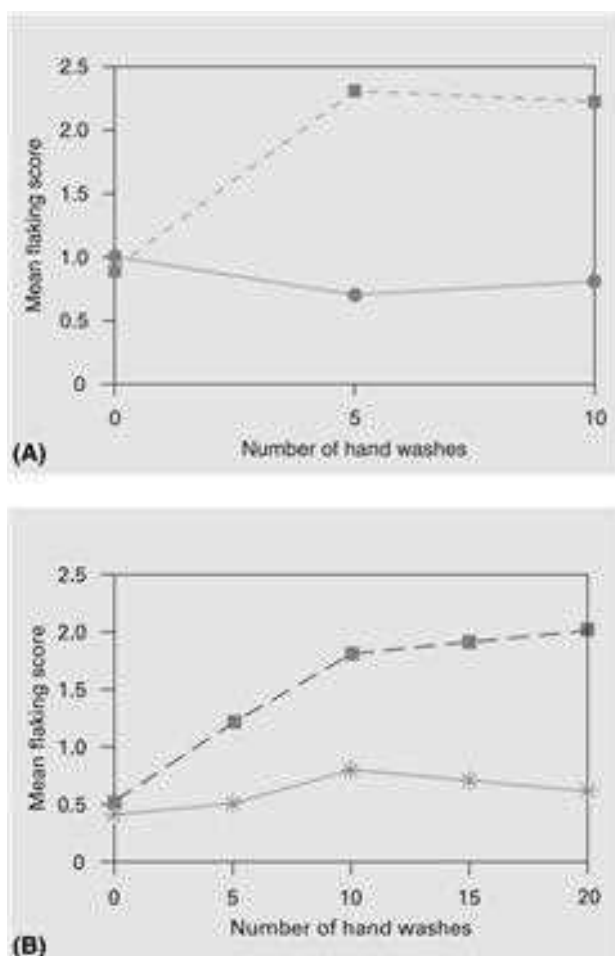
**Preventing the return of dry skin** Effective moisturizers are able to prevent the return of dry skin; even after product applications have stopped. The residual effect is important to consumers who wish to maintain their skin's good condition until the next convenient application time, even though it is still exposed to the stresses that caused the dryness in the first place. Both the single application test and the regression test are able to do this. An effective product has moisturized the skin, and the decay of the benefits can be measured after application ceases. A slow return to baseline is indicative of an efficacious product with lasting effects. Figure 33.4 shows the data obtained by Kligman for two cosmetic moisturizing ingredients, petrolatum and lanolin. The data clearly demonstrate product efficacy during the treatment and regression phases. During the regression, persistent moisturizing effects are demonstrated 21 days after the last treatment with petrolatum but only two weeks for lanolin.

A more direct approach to measure the prevention of dry skin was developed by Highley et al. (22). In the Highley hand wash protocol, the analysis begins with nondry, healthy skin. The panelists wash their hands with bar soap for one minute five times a day over a four-day period. One hand remains otherwise untreated, while lotion is applied to the other hand after the first four washes of the day. The condition of the skin is assessed by a trained observer and by instrumental measurements before the first wash of the study (baseline) and approximately one hour after the last (fifth) wash each day. Results show that ingredients such as petrolatum and effective commercial lotions can prevent the induction of dry skin, which can be considerable on the untreated hand (Fig. 33.6 and Table 33.2). By determining the difference between the treated and untreated hands, more than one product or ingredient can be compared. Although panels as small as 5 were used by Highley, it is more usual to use panels of 15 or more to enable the data to be statistically analyzed. Recently the test has been modified so only a defined area of each hand is treated with lotion. The surrounding area acts as that hand's "no-product" control.

**Reducing primary irritation** An adverse environment or working conditions may drive the skin beyond dryness (xerosis) into the realm of primary irritation and dermatitis. In recent years many scientists and dermatologists have realized that moisturizers may reduce the propensity of the skin to develop primary irritation and help accelerate its reduction should it occur. A review by Zhai and Maibach gives a good overview on the subject (24). The prevention of irritation and its reduction when it does occur can be modeled separately.

Hannuksela and Kinnunen (1992) (25) performed a similar study using one-minute washes with dishwashing liquid, twice a day, on the arms over a seven-day period. The authors evaluated cleanser induced irritation using transepidermal water loss (TEWL) as a measure of SC integrity and Laser-Doppler flowmetry to assess blood flow. They demonstrated that moisturizer application could prevent surfactant induced skin damage and accelerate repair compared with no treatment, but were unable to differentiate between products.

Another approach was that of Loden and Andersen (26). They used occlusive patching with 0.5% SLS to generate primary irritation, then applied different lipids to accelerate that rate at which the skin repaired itself. They utilized observer



**Figure 33.6** Ability of petrolatum (A) and lotion (B) to prevent the induction of skin flaking by repeated washing with soap, petrolatum, and lotion, and no treatment. *Source:* From Ref. 23.

**Table 33.2** The Ability of Ingredients to Prevent the Induction of Skin Dryness due to Repeated Hand Washings with Soap

Ingredient	Ability to prevent dryness (higher the score the more effective the ingredient)
Petrolatum	54
Mineral oil	49
Glycerin (25% aqueous solution)	34
Sorbitol (25% aqueous solution)	14
Propylene glycol (25% aqueous solution)	-1

*Source:* From Ref. 22.

and instrument measures of erythema to assess the skin's response and hydrocortisone as the positive, effective, control. They found that soy sterols that had a beneficial effect. This model has been modified using 5% soap to cause the irritation and evaporimetry to assess SC barrier function. In this case 1% hydrocortisone (an OTC drug in the United States), was effective at reducing erythema but the results on barrier function

appeared to be dependent on the vehicle rather than the hydrocortisone itself. Some high glycerin containing moisturizers are also very effective at accelerating erythema reduction and restoring barrier integrity (27). This is consistent with the observations of Fluhr and his colleagues on the restorative properties of glycerin.

**Preventing primary irritation** The ability of moisturizers to prevent detergent induced skin dryness has important public health implications. Dermatitis is a leading occupational disease and professions that involve frequent hand washings are at particular risk. Frequent, effective moisturization may provide a significant preventative benefit. However, moisturization or using a barrier cream does not provide sufficient benefit alone. Their use must be part of a comprehensive education program to be able to provide a tangible benefit in the workplace (28).

There are two main models that assess the ability of a moisturizer to prevent primary irritation. They are the occlusive patch test and a repeated washing test. In the former, test products are applied to the skin and allowed to dry—about 30 minutes. Occlusive patches with dilute SLS solutions are applied for 24 hours and then removed. Twenty-four hours later, primary irritation is assessed by a trained observer, by colorimeter and by evaporimetry. A no-product site is used as a control. High glycerin cationic emulsions were shown to be more effective at preventing the induction of primary irritation than hydrocarbon based moisturizers that form occlusive barriers (27).

Similar methods have been utilized to assess the ability of barrier creams to reduce or even prevent the induction of irritation (29). For instance, Schentz et al. (30) standardized the repeated short-term occlusive irritation test (ROIT) to assess the ability of test barrier creams to reduced irritation induced by toluene or 0.5% aqueous solutions of SLS. Sites on the volar forearm were pretreated with the test creams at 25 mg/cm<sup>2</sup>. Ten minutes later the irritants were applied under occlusion for 30 minutes. This was repeated 3.5 hours later, and the twice a day treatment was used for two weeks (excluding the weekend). All four test centers found that the petrolatum based creams were effective at reducing SLS induced irritation as measured by TEWL rates and erythema measurements (both trained observer and colorimeter), but appeared to have a less consistent protective effect against toluene, possibly because of the hydrophobic nature of both petrolatum and the solvent. Wigger-Alberti et al. (31) used a similar approach. They applied petrolatum to sites on the ventral forearm of 20 volunteers. Thirty minutes later, test irritants such as aqueous solutions of lauryl sulfate, sodium hydroxide and lactic acid as well as toluene were applied for 30 minutes. This process was repeated daily for two weeks. Assessments of skin condition by erythema scoring, chromameter, and TEWL demonstrated that petrolatum could reduce irritation although it appeared least effective against lactic acid.

**Instrumental evaluations of moisturizer efficacy** Instrumental evaluation of skin condition is often used to supplement to visual assessments in clinical moisturization protocols. They provide an objective method to evaluate a specific skin parameter. For example, Raman confocal microscopy and conductance/capacitance have been used as direct and indirect measures of skin hydration, respectively. TEWL is a measure of SC barrier function by measuring water flux from the skin. It must be emphasized that a single instrumental parameter should not be used alone as a measure of moisturization. Instruments

measure a defined physical parameter, which may not always correlate with moisturization or skin condition. For instance, hydrophobic materials such as petrolatum, silicones or mineral oil that can be effective moisturizers reduce skin conductance immediately after application. This contradicts the usual interpretation of this parameter that correlates increased conductance with moisturization. Instead the bioinstrumental measurement should be used to support and expand on observer scoring and panelist self-assessment, and if possible multiple bioinstrumental measures should be used simultaneously.

Several bioinstrumental methods will be briefly reviewed in this chapter. More thorough reviews of bioinstrumentation are available in the literature (32–36).

### Measuring Skin Dryness

Biophysical methods have been developed as alternatives to assessments by a trained observer. Chief amongst these is assessing skin dryness harvesting skin scaling with D-Squame<sup>®</sup> sticky tape strips, then quantification by computerized image analysis (19,37). D-Squame tapes consist of clear plastic disks with a homogenous layer of adhesive on one side. The disk is pressed against the skin using uniform pressure. Scales on the surface of the SC are removed along with the disk. These scales can be readily visualized when placed on a black background and scored with a 0 to 4 analog scale or image analysis (19,36). Have analyzed D-Squame disks using image analysis. Prall's quantization utilized reflected light from the scales. The analysis of Schatz et al. included both the area of scale coverage and the thickness of the scales to yield a desquamation index (DI). This approach appears to be superior to observer scoring as skin scales are readily obscured from trained observer by high humidity or products that matt the scales down but do not cause desquamation. However, as they are still present on the skin's surface, they still can be harvested by the sticky tape and quantified. An ingredient or product that causes desquamation will lower the measured DI. This was demonstrated in a regression test that compared lotions C and E, with a no-product control. While the trained observer perceived few differences, both D-Squame and conductance demonstrated that product C was significantly more effective than lotion E or the no-product control (Fig. 33.7).

### Assessing the Integrity of the Stratum Corneum's Surface

Squamometry has been developed as a method of assessing the integrity of the corneocytes on the SC surface. D-Squame tape is used to harvest the surface corneocytes, which are then treated with a hydrophilic stain, such as polymultichrome stain (PMS). If the corneocytes are in good condition, they do not take up stain and remain relatively clear, and in large sheets. Damaged corneocytes appear in smaller clumps, and take up stain to give a purple color (Fig. 33.8). This can be quantified by colorimetry.

Since it is measuring damage to the surface corneocytes, squamometry is a very sensitive measure of damage to the skin's surface. Previously, Simion et al. showed that increased color uptake correlated to the sensory irritation produced by different cleansing bars, before any clinical signs were observed (38). Similarly, Pierard et al. showed that squamometry could demonstrate that fabric softeners could reduce damage on sensitive skin (39).

Dry skin, as a failure of the normal desquamation process, resulting in damaged corneocytes remaining on the surface. There is much staining of the harvested cells. An effective moisturizer causes desquamation, removing the damaged cells, so that the surface corneocytes are in good condition and staining is reduced. Under the microscope less damage to the corneocytes is observed (Fig. 33.8).

### Measuring Skin Surface Topography

New optical methods have been developed to assess the changes that a lotion can produce on skin topography more quickly and with less damage than silicone replicas previously used. One example is the Visioscan that rapidly measures and quantifies skin dryness, smoothness, volume, and texture utilizing the "surface evaluation of living skin" (SLES) parameters (40). It uses UVA light sources to illuminate a small area (6 × 8 mm) uniformly and then the light reflected by the SC is captured by CCD camera with a high resolution black and white chip. When skin is hydrated using a moisturizer the flakes at the skin's surface are no longer observed (Fig. 33.9).

### Spectroscopic Methods for Evaluating Skin Microstructure

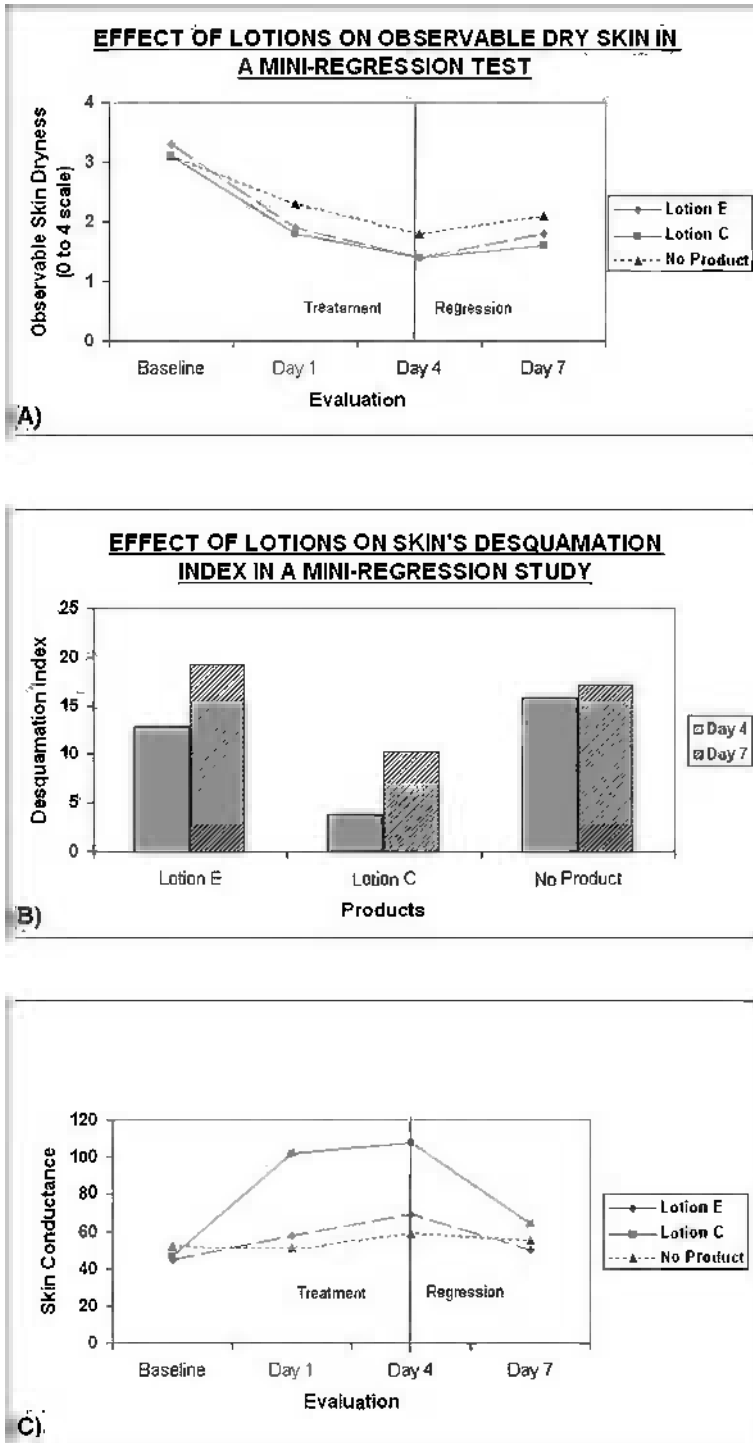
Different components of the skin such as hemoglobin, melanin and collagen have the ability to absorb light at different wavelengths. By capturing and analyzing the reflected light for the different chromophores at different points across a large area, it is possible to build a map of the underlying surface structure down to a depth of about 2 mm. Using this method, Matts et al. showed that as the skin ages the distribution of both hemoglobin and melanin in sun exposed skin becomes more diffuse, less homogenous. This could be used to measure the effects of antiaging lotions on the skin (41).

### Measuring Water Content of the Skin

In recent years, direct measurements of the skin's water content have been developed. A leader in such methods is confocal Raman microscopy. This method is able to measure the water content at different depths of the skin. Water being present in such large amounts, is a dominant contributor to the skin's absorption spectra. However, other molecules can be observed, especially if they have distinct absorption peaks. The use of deuterated glycerin and lipids is one approach to measuring the absorption of common skin care ingredients.

Egawa and Tagami used confocal Raman spectroscopy (CRS) to measure the effects of season age and body site on the water profile in the SC (42). They showed that the SC apparent thickness of the forearm was greater in older Japanese volunteers compared with younger ones. This was not observed on the cheek. Although the humid Japanese summer resulted in an increase in skin capacitance, there was no change in the depth profiles for water in the SC. The capacitance change could be due to variations in the concentration of water binding molecules especially urea and lactate near the skin's surface in the summer. In contrast, applying water soaked cotton wool to the skin for 15 minutes or more resulted in increasing water content especially close to the skin's surface (the point of application).

Crowther et al. examined the effects of lotions on the skin using confocal Raman microscopy together with optical

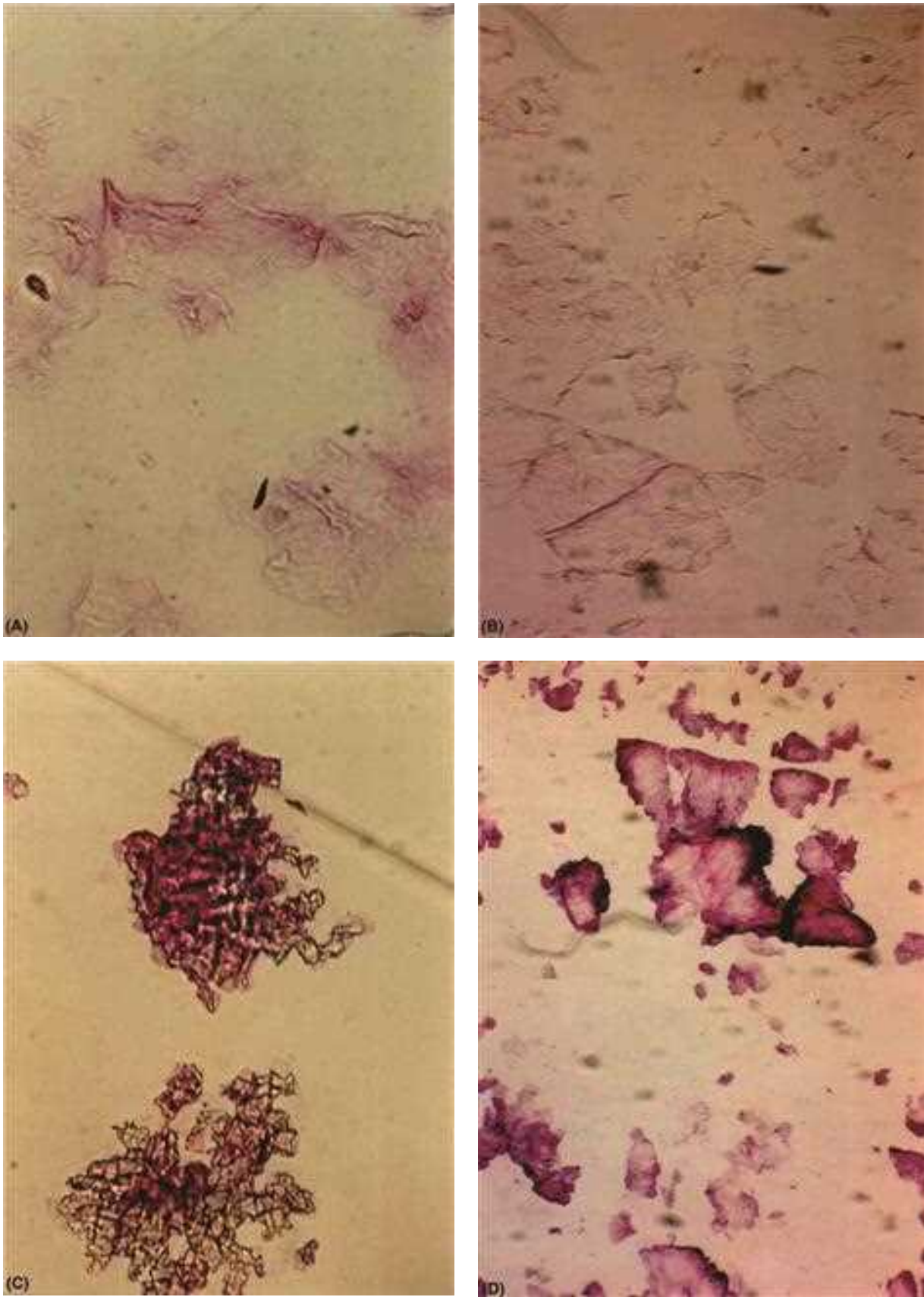


**Figure 33.7** Effect of lotions E and C on (A) observable dry skin in a miniregression test, (B) the skin's desquamation index in a miniregression study, and (C) the skin's hydration as measured by conductance.

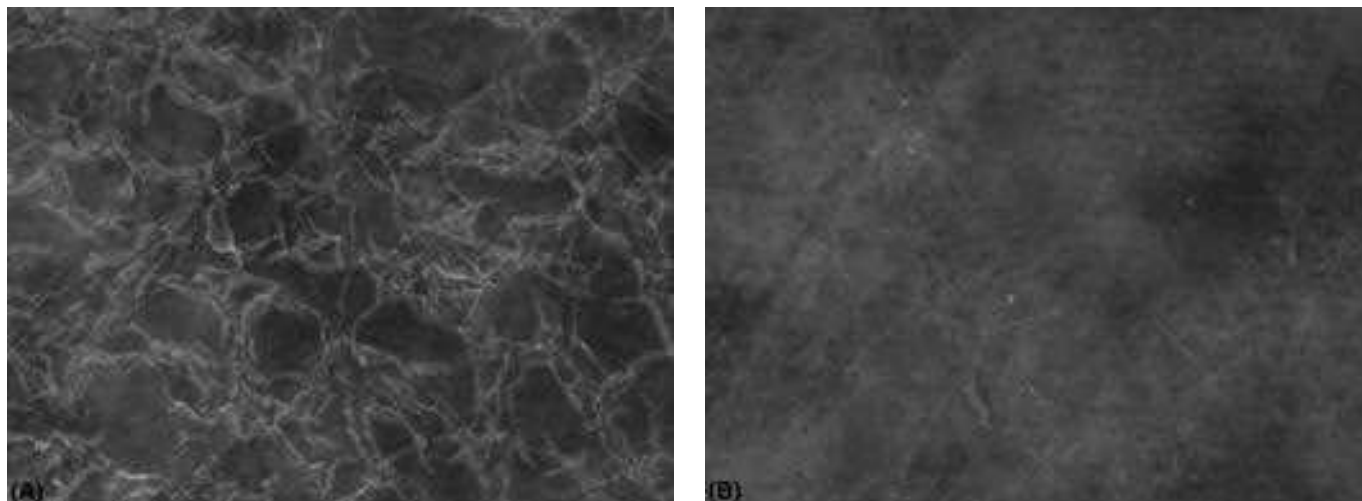
coherence tomography (OCT) and skin capacitance (43). They showed that there was a strong correlation between the width of the SC measured by CRS and OCT:  $R^2 > 0.93$ . However, CRS was better able to measure SC width at body sites where it is naturally thinner, than OCT. When measuring the effects of three lotions on volar forearm skin after two weeks of treatment and one week of regression, Crowther et al. showed that only one effectively raised the water content of the SC, whereas skin

capacitance increased for all three. It was hypothesized that the increase in capacitance was due to glycerin from the lotions being absorbed into the skin.

Additionally, confocal Raman microscopy can be used to measure the absorption rate and depth of many compounds applied to the skin, especially those that have absorbance peaks that are different from those of the skin's endogenous absorption spectrum.



**Figure 33.8** Effect of lotion in preventing the reduction of surface corneocyte integrity. With lotion: (A) stained D-Squame<sup>®</sup> disk and (B) magnification of  $\times 100$ . Without lotion: (C) stained D-Squame disk and (D) magnification of  $\times 100$ .



**Figure 33.9** Effect of lotion on the appearance of the skin's surface. (A) Before lotion application and (B) eight hours after lotion application.

Unfortunately, the confocal Raman microscopy instrument is still very expensive. Therefore in routine moisturizer efficacy testing, indirect electrical measurements still have an important role.

The four most common instruments for measuring the skin's electrical properties are the Skicon<sup>®</sup> and Dermalab<sup>®</sup>, which measure skin conductance, and the Corneometer<sup>®</sup> and Nova<sup>™</sup> Dermal Phase Meter, which measure skin capacitance. These parameters that are not identical have been shown to strongly correlate to each other in moisturizer studies [ $R^2 = 0.92$  (44)]. Conductance measures the ability of a very small electrical current to pass through the skin, whereas capacitance measures the ability of the skin to hold a charge. However, in practice the two parameters increase with hydration level produced by increasing the water content of the skin. Conversely, artificially or weather induced dry skin holds less water and also has air pockets between the scales, the latter causing a white appearance. These lower both conductivity and capacitance. Measurements are rapid, in the order of seconds, and reproducible. However, it is important that the subject is in a relaxed state in a climate controlled environment to remove any contributions from sweat or from variable environmental conditions. Another source of error can result from product residue (45). Measurements taken immediately after lotion application will be especially high before the water from the vehicle has completely evaporated. In the opposite scenario, the presence of a hydrophobic product residue, such as petrolatum, will lower the measured value even if the hydration level of the skin is higher.

### Skin Elasticity

The elasticity of skin is widely recognized to decrease with chronological and photodamaged induced aging and has been shown experimentally to increase with hydration level (46). Though many devices have been used to measure elasticity in vivo, only a few are commercially available (47,48). The Dermal Torque Meter<sup>™</sup> was designed to apply a torsional force (twist

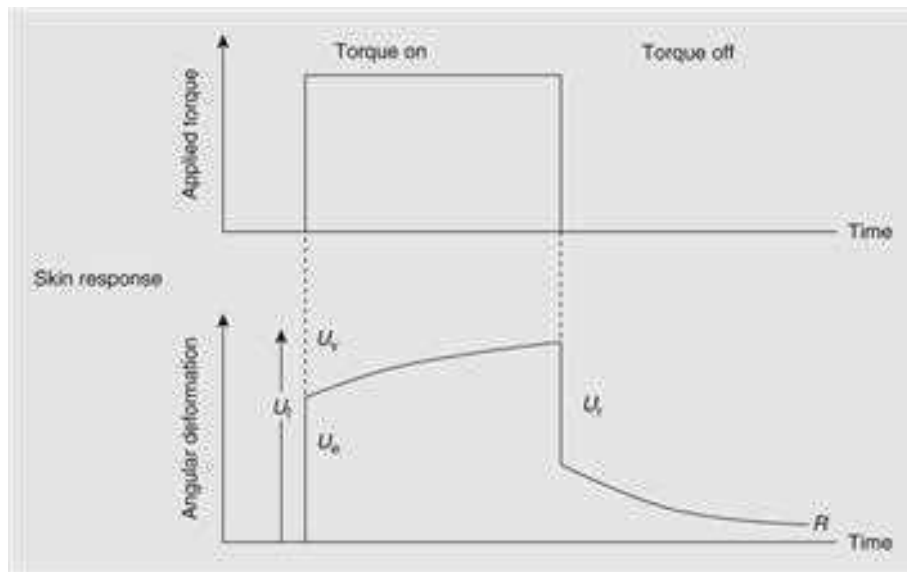
in the plane of the skin and measure the deformation and relaxation of the affected skin. The Cutometer<sup>®</sup> and Dermalab<sup>®</sup> both apply a vacuum suction perpendicular to the skin surface and measure the resultant displacement and relaxation of the skin, that is, snap back. Regardless of whether the force is applied perpendicular or parallel to the plane of the skin, the data are described by the same standardized parameters (Fig. 33.10). That different instruments deforming the skin in different ways use the same parameters has caused much confusion in the past.

There is a rapid initial deformation ( $U_e$ ) as the force is applied followed by a slow viscous "creep" ( $U_v$ ) if the applied force remains constant. As the skin is moisturized and becomes more plastic and flexible, both parameters increase. The final (total) deformation is termed  $U_f$ . When the force is released, the skin relaxes rapidly ( $U_r$ ), though only partially, toward the preforce position. Over a longer period of time the skin relaxes back to its original state by viscous flow ( $U$ ). All of these parameters are dependent on the thickness of the skin assessed. This in turn is dependent on the size and geometry of the probes utilized and how well the probe isolates the measurement site. Ideally, for moisturizers the probes should assess the SC only. As this is difficult to accurately assess the elasticity data are frequently presented as ratios. The ratio  $U_r/U_f$  is called the biological elasticity.

Although measurements can be completed within seconds, the techniques are not completely noninvasive. The skin may take up to an hour to completely return to its baseline values and in the case of the Dermal Torque Meter will undergo alterations from a tape-stripping effect of the adhesive used to attach the probe.

An alternate approach to skin softness/elasticity is to use the "tactile sensor." This instrument measures skin softness by a change in frequency of a probe tip that resonates in the kilohertz range. Upon application to a soft, readily deforming surface the probe travels further and appears to slow (49). This results in a reduction in observed vibrational frequency.





**Figure 33.10** Parameters used in assessing the viscoelastic properties of the skin. *Abbreviations:*  $U_t$ , total stretch;  $U_e$ , immediate deformation;  $U_r$ , immediate relaxation;  $U_v$ , viscous stretch;  $U_r/U_t$ , skin elasticity ratio;  $R$ , residue.

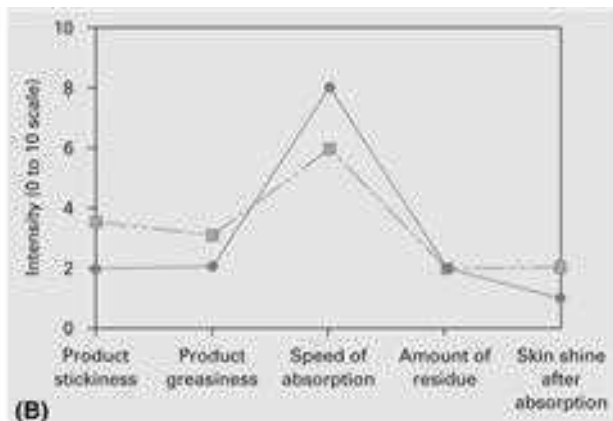
### Consumer Evaluation of Moisturizer Performance

Consumer testing is a vital tool by which industry assesses acceptability. Usage testing provides the most consumer relevant information available. Not only about moisturization performance, but also about the entire product's esthetics such as fragrance, appearance as well as tactile properties including greasiness and spreadability.

These studies utilize large panels, frequently hundreds of consumers who use the test moisturizer(s) for a designated period according to their normal routine. Once consumers have tried the product for themselves, they are debriefed with interviews and written questionnaires or in focus groups. Feedback on product attributes such as greasiness, stickiness, and afterfeel enables the cosmetic formulator to optimize the products to the needs of the target consumers.

### Product Evaluation by a Trained Expert Sensory Panel

Since large scale consumer testing is time consuming and expensive, the intensity of product attributes including stickiness, greasiness and afterfeel be rapidly evaluated by a trained expert sensory panel. One such method is the skin feel spectrum descriptive analysis (skin feel SDA) used by Meilgaard et al. (50). This method outlines the product attribute descriptors and scoring scales used to evaluate moisturizers. An expert panel of 8 to 15 persons is required to complete many hours of training to ensure they can reproducibly quantify moisturizer and skin attributes such as spreadability, amount of residue and absorbency, which are scored using a 0 to 10 scale (Fig. 33.11). Once the panel is calibrated, they can be used to evaluate competitors' products and optimize new formulas. It should be noted that



**Figure 33.11** Expert panel testing of lotions. (A) Product application. (B) Prototypical results for the sensory profile of two lotions: lotion A and lotion B.

**Table 33.3** Common Descriptors of Moisturizer Efficacy Used in Advertising

Action of moisturizer	Description of skin	Other claims
Controls dry skin	Severe dry skin	Long-lasting relief
Heals dry skin	Extra dry skin	Fast relief
Protects dry skin	Overdry skin	Penetrates skin
Relieves dry skin	Rough, dry skin	Soft, smooth, healthy skin
Ends dry skin	Normal to dry skin	Lasts up to "x" hr

these panels measure attribute intensity only, and do not assess the preference of different consumer groups.

### Advertising Claims Made for Moisturizers

Modern day hand and body moisturizers have been developed to meet the varied needs of today's consumers. These products span the range from lightweight lotions designed to provide a pampering feeling for normal skin to heavy, greasy creams formulated to relieve severely dry skin. The manufacturers of these products make many claims concerning product efficacy. Some of the common descriptors found on hand and body lotion packaging are listed in Table 33.3 below.

Any claim that is made on these packages must be supportable by the manufacturer. If the label is found to be false the product is considered to be misbranded under Section 601 of the Federal Food, Drug and Cosmetic Act (FDC). A deceptive act or practice, that is, a false claim, is also illegal under Section 5 of the Federal Trade Commission Act (FTC). The industry is largely self-regulated by the National Advertising Division (NAD) of the Council of Better Business Bureaus through which competitors or outside agencies can challenge claims made in advertising. In deciding whether a claim has been adequately substantiated the NAD assesses three types of support: rationale, subjective data, and objective data (51). The manufacturer will use a combination of test methods reviewed earlier in this section, to provide the necessary support.

## THE TOXICOLOGY OF HAND AND BODY LOTIONS Overview

Although cosmetic hand and body lotions are leave-on products, they have a low rate of adverse reactions in normal usage. Adams and Maibach (13) reported that cosmetics caused 5.4% of the contact dermatitis cases studied by the North American Contact Dermatitis Group (NACDG) from 1979 to 1983. Hand and body lotions were probably a small group within this total based on the type of product and body site of reactions. This is supported by more recent data from the U.S. Food and Drug Administration (FDA). They reported that for the years 1991 to 1994, hand and body lotions caused approximately three "possible allergic or other serious irritation" reactions for the first million units distributed. In contrast facial moisturizers caused six reactions for the first million units distributed and bath soaps caused 45—Cosmetic Product Experience Report Summary. This indicates that the hand and body lotions developed and sold by leading U.S. manufacturers deliver their benefits with little risk to consumers. However, even with minimal rates of adverse reactions, some consumers do experience reactions. This section will review the types of adverse reactions experienced by consumers, the materials that may cause the reactions and how industry tests for them.

Most adverse reactions to hand and body lotions experienced by consumers are forms of primary dermal or sensory irritation. These are usually dependent on three factors.

1. The lotion's composition
2. The condition of consumers' skin
3. How consumers use the product

### Lotion Composition

The first point appears self-evident. If a product does not contain any potential irritants, then it is unlikely to cause irritation. Lotion manufacturers strive to market nonirritating and nonsensitizing products.

However, the addition of beneficial ingredients to lotions can cause adverse reactions. Such ingredients include sunscreens and AHAs that may cause sensory irritation such as facial stinging or burning, in about 15% of the population. Preservatives such as quaternium-15 and Kathon CG can potentially cause sensitization but are required to prevent microbiological contamination of products. Such contamination, especially by Pseudomonads, could pose a greater threat to a larger number of consumers. Novel delivery systems, skin protectants and antiirritants have been used to reduce adverse reactions by limiting release of, or penetration into the skin of potential allergens or irritants. Responsible manufacturers seek to minimize these risks for lotions, which consumers essentially regard as being "risk-free," while maximizing the benefits to their consumers.

### Role of Consumers' Skin Condition

Most hand and body moisturizers are well tolerated by the general population as evidenced by the low adverse reaction rate reported by the FDA. However, there are subgroups of consumers that respond adversely to a product or ingredient, more readily than the general population. There are several different reasons for this phenomenon. People with a damaged SC barrier due from preexisting trauma or pathology may be more reactive, especially to marginal or cumulative irritants. This group includes people with atopic dermatitis, or chronic preexisting irritation.

A subset of the population experiences sensory irritation—stinging or burning, when they apply lactic acid or sunscreens to their facial skin. This sensory irritation is distinct from detergent induced irritation. This conclusion is based on the observations that sodium lauryl sulfate, an irritating surfactant does not cause stinging (52) and stingers to lactic acid, demonstrate a wide range of irritation responses to lauryl sulfate (53).

Finally, people with a known allergy must avoid exposure to that allergen. Listing the ingredients in all cosmetic and OTC drug products sold in the United States facilitates this process. If there are any questions, especially about a fragrance component, the lotion manufacturer should be contacted. The names of the contact persons for each major U.S. manufacturer, is listed in the "CTFA on Call" book. This is distributed annually to all members of the American Academy of Dermatology.

### How Consumers Use the Product

Usually, consumers do not misuse hand and body lotions in such a way that they are harmed. Most lotions are relatively mild to the eyes and are not toxic when ingested. However, this may not be the case for all products, and it is advisable to contact the manufacturer in case of a question.

## PREDICTING ADVERSE SKIN EFFECTS

### Primary Dermal Irritation

Erythema occurs when the concentration of an irritant and the time and conditions of skin exposure, exceeds a critical threshold level. Redness is usually localized to the exposure site. It may occur rapidly after the first exposure to an acute irritant or after several applications of a weaker or cumulative irritant. Diagnostically, irritation is frequently differentiated from sensitization reactions by factors such as the following:

- The composition and dose of the product
- If the response occurs after the first usage
- Its rapid onset after usage
- The type and spreading of the reaction
- How long the erythema and/or swelling lasts

Lotion manufacturers routinely probe for this type of information when consumers complain concerning an adverse reaction and may utilize a dermatologist to diagnose or follow-up as appropriate. Ingredients that can cause primary irritation in lotions are frequently anionic surfactants used as emulsifiers, or AHAs that are added for their antiaging benefits.

A sensitive method to assess and differentiate lotions on the basis of their primary dermal irritation potential is the cumulative irritation test (CIT) (54). Panelists are randomly selected from a general population. The product is applied under an occlusive patch for 24 hours. The patch is removed and the site is evaluated for irritation using a 0 to 3 scale. Traditionally, this process is repeated for 21 consecutive days with patches remaining in place over the weekend. However, Berger et al. developed a test where applications are only made for 14 days (55) and showed that this modification gave the same line up of irritation potentials as the 21-day study, but with a reduced chance of tape reactions. The cumulative irritation score in a panel of 10 to 25 subjects is a measure of primary irritation potential. The mean cumulative score per panelist for most lotions is low—less than 5 out of a possible 45 in the 21-day test. In contrast a 0.1% SLS solution, which is used as a positive control, usually yields a mean cumulative score per panelist that exceeds 20.

An alternative method for assessing irritation potential utilizes the induction phase of the human repeated insult patch (HRIPT). Although this test's primary purpose is to identify sensitizing ingredients or products, it begins with an induction phase. During induction, usually 100+ panelists are occlusively patched with the product for 24 to 48 hours, over a three-week period. In the case of the Jordan-King and Maibach-Marzulli variants of the HRIPT the patches are applied for 48 hours and are removed shortly before scoring and repatching. As in the 21-day CIT, the skin does not have time to recover. Indeed this methodology resembles the 21-day CIT, but on a larger scale. After the induction phase, the panel is rested. Two weeks later, panelists are challenged by patching with the product at a naive as well as the original site, to determine sensitization potential.

Damaged skin may be more readily irritated than "normal" skin. This has been confirmed epidemiologically for occupations that involve repeated hand washings such as nurses and kitchen workers have significantly higher rates of hand dermatitis than their cohorts that do not do "wet" work, for example, clerical workers (56). Atopy also increases the risks of occupational dermatitis. Such effects can be modeled. For instance, Freeman and Maibach showed a greater TEWL response on skin repatched with lauryl sulfate two weeks after the initial insult, even though the skin appeared normal (57). This suggested that there was a level of subclinical or "invisible dermatitis" still

present at the cellular level. Indeed Kligman reported that patching with 0.5% lauryl sulfate can cause spongiosis even though again the skin's surface appears normal (58). Typically, subclinical levels of skin damage are caused by cold winter weather, repeated exposure to detergent solutions, that is, wet work, or physical microtrauma. It has been suggested that the use of ancillary cosmetic or cleansing products can cause subthreshold levels of irritation. Subsequent application of a second product, such as a lotion, may elevate the irritation above the threshold resulting in observable irritation (59).

To examine the role of the stratum corneum in preventing irritation, Frosch and Kligman developed a model (60). The stratum corneum is mechanically damaged by scratching with a needle and then is occlusively patched for three consecutive days. They showed that damaging the hydrophobic stratum corneum barrier reduced the concentration of water-soluble compounds required to cause irritation: 10 fold for sodium lauryl sulfate to 50 fold for nickel salts. The threshold concentration to cause irritation by lipophilic irritants such as Triclosan or fatty acids was reduced less than six fold by this method.

The final approach to assess the irritation potential of a product on a vulnerable group is to have individuals from that group, for example, atopics or lactic acid stingers, use the product under exaggerated conditions.

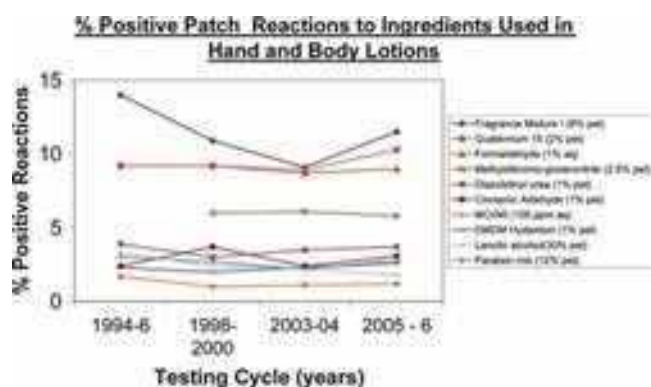
### Sensory Irritation

This type of irritation is more common than many people realize. It may cover several different mechanisms, such as subclinical irritation, and low-level contact urticaria as well as effects like lactic acid stinging. Indeed over half the adverse reactions to cosmetics involve sensory irritation in the absence of any visible signs (61). Frosch and Kligman (1977) examined many ingredients for their potential to cause facial stinging and showed that 5% lactic acid, and sunscreens such as PABA had the potential to cause facial stinging in approximately 15% of the population (52). It is unclear what the rate of reaction would be on other parts of the body. Undoubtedly, it would be lower. More recently Christensen and Kligman showed that damaging the skin by repeated facial washing with soap would enhance the stinging response (62). Low levels of cinnamic aldehyde (0.01%) have been used to cause tingling in chewing gum. At higher concentrations it can produce visible contact urticaria and with repeated exposure sensitization.

#### *Sensitization*

Delayed (type IV) contact hypersensitivity. Typically, dermatologists are most familiar with this type of adverse reaction. From 1979 to 1983 the NACDG reported that 60% of adverse reactions to cosmetic products observed by the group, were allergic in nature (13). This differs from epidemiological data that indicates that most adverse reactions are due to irritation (61). This difference may reflect the greater intensity and duration of allergic reactions that would require medical intervention. The leading allergens identified by the NACDG that are found in cosmetics include fragrances and preservatives such as balsam of Peru, fragrance mix, quaternium-15, and formaldehyde. The sensitization rates have not changed much in the last 12 years (Fig. 33.12 and Table 33.4) (63).

Sensitization to ingredients may occur more readily on damaged or irritated skin. Previously, parabens had developed a reputation as a potential sensitizer. However, this may be due to parabens being used to preserve medicaments for dermatitic



**Figure 33.12** The rates of positive dermal allergic reactions in patch testing run by the North American Contact Dermatitis Group over a decade. *Source:* From Refs. 63–66.

skin. The parabens will penetrate the damaged stratum corneum more readily and be more available to induce sensitization reactions (67). Recent epidemiological data has shown parabens to have a relatively low sensitization rate compared with other preservatives (63).

#### Preservatives

Lotion manufacturers prefer to avoid potential allergens by excluding them from products. When this is not possible, such as in selecting effective preservatives, then the least sensitizing product that ensures microbiological integrity is utilized. The preservatives frequently used in U.S. products are listed in section “Ingredients for Hand and Body Lotions.”

#### Fragrances

There is a fragrance industry organization, Research Institute for Fragrance Materials (RIFM), that evaluates the safety of individual components. It recommends if a component should be used not be used or if there is maximum safe level. Most major U.S. manufacturers follow or even exceed these guidelines. It should be noted in the last few years that the RIFM has updated their guidelines basing them more on risk assessment and the class of product and type of exposure consumers will experience (68).

#### Sensitization Testing

After reviewing the proposed ingredients for potential allergens, lotion manufacturers utilize the HRIPT to experimentally confirm that the product or its components do not sensitize. This testing involves occlusively patching a panel of over 100 individuals from the general population, for up to three weeks with a test material. After a two-week rest period, the panelists are challenged with a 24- to 48-hour patch and the response is evaluated (69). If the responses at challenge are greater than that during the induction phase, are long lasting—increasing in the 48 hours after patch removal, or spread beyond the patch site—there is a possible sensitization that should be investigated further. Predamaging the stratum corneum with sodium lauryl sulfate can enhance the sensitivity of the test (70). This method known as the maximization test is not often used as it causes many false positives.

#### Acnegenesis and Comedogenesis

These two terms are frequently used interchangeably, although they likely represent different biological events. Acnegenesis is the occurrence of breakouts, blackheads, and white heads, especially on the face but also on the back. Frequently there is a strong inflammatory component that is not observed in comedogenesis. Inflammation is due to *Propionibacterium acnes* proliferation and the body's immune response to them. Lesions seem to appear rapidly, although formation of the initial hyperkeratotic plug may occur subclinically over a longer period.

Comedogenesis was originally the term given to the formation of large hyperkeratotic impactions due to exposure to chlorinated hydrocarbons. Such exposure can result from industrial accidents such as in Sarveso, Italy. These comedones do not have an inflammatory component, are larger and develop more slowly than facial acne.

The interchangeability of the terms arose from two factors. The first is mechanistic—both events involve the formation of hyperkeratotic plugs. Secondly, the original models for assessing comedone formation—the rabbit ear test and comedone formation on the human back are more convenient than for acnegenesis (71,72). This enables many products and ingredients to be readily assessed and claims made that a product is noncomedogenic. Comedogenic materials include branched and unsaturated fatty acids and esters. However, combining these ingredients into products can greatly modify their comedogenic potential. Indeed the oil used to dissolve a fatty acid greatly modifies its comedogenic potential (Table 33.5). In

**Table 33.4** Percentage of Positive Patch Test Reactions to Ingredients Used in Hand and Body Lotions

Compound/mixture	Years tested			
	2005–2006	2003–2004	1998–2000	1994–1996
Fragrance mixture I (8% petrolatum) <sup>a</sup>	11.5	9.1	10.9	14.0
Quaternium 15 (2% petrolatum)	10.3	8.9	9.2	9.2
Formaldehyde (1% aqueous)	9.0	8.7	9.2	9.2
Methylchloroisothiazolinone/methylisothiazolinone (2.5% petrolatum)	5.8	6.1	6.0	Not recorded
Diazolidinyl urea (1% petrolatum)	3.7	3.5	3.0	3.9
Cinnamic aldehyde (1% petrolatum)	3.1	2.4	3.7	2.4
Methylchloroisothiazolinone/methylisothiazolinone (100 ppm aqueous)	2.8	2.2	2.7	3.0
DMDM hydantoin (1% petrolatum)	2.6	2.3	2.0	2.3
Lanolin alcohol (30% petrolatum)	1.8	2.2	2.4	3.3
Paraben mix (12% petrolatum)	1.2	1.1	1.0	1.7

<sup>a</sup>Concentration tested and vehicle.

*Source:* From Refs. 63–66.

contrast, the test method for acnegenicity requires a panel of at least 40 normal and acne prone subjects to use a product on their faces for at least six weeks. A nonacnegenic product will not significantly increase the level of acne over this test period (75). This is a more expensive test than patching since each panelist can test only one product at one time.

#### Contact Urticaria

Clinically defined contact urticaria is often characterized by the rapid formation of wheals or flares frequently within an hour of

exposure to a causative agent. Either an immunological or a nonimmunological pathway can cause this. However, the exact molecular and cellular mechanisms are not well understood.

Potential urticants that may occur in cosmetic products include the preservative benzoic acid, and fragrance components—cinnamic aldehyde and balsam of Peru. It should be stressed that the incidence of reaction to these ingredients are not known, so the epidemiological importance of these is not clear. At lower concentrations, many urticants can produce sensory irritation, especially itching or tingling, without

**Table 33.5** Comedogenicity: Its Relationship to Primary Irritation and Modification by Vehicle and Different Testing Models

A. Comedogenicity and irritation potential of cosmetic ingredients in the rabbit ear model		
Ingredient	Comedogenicity	Irritation
<b>Oils</b>		
Coca butter	4	0
Coconut butter	4	0
Evening primrose oil	3	2
Soybean oil	3	0
Peanut oil	2	0
Castor oil	1	0
Sunflower oil	0	0
Mineral oil	0–2	0
<b>Lanolin and derivatives</b>		
Acetylated lanolin	0	0
Acetylated lanolin alcohol	4	2
Anhydrous lanolin	0–1	0
Lanolin alcohol	0–2	0
PEG-16 lanolin	4	3
PEG-75 lanolin	0	0
<b>Fatty acids and esters</b>		
Lauric acid	4	1
Myristic acid	3	0
Palmatic acid	2	0
Stearic acid	2–3	0
Butyl stearate	3	0
Cetyl acetate	4	2
Cetyl ester NF	1	1
Isopropyl isostearte	5	0
Isopropyl lineolate	4	2
Isopropyl myristate	5	3
<b>Alcohols sugars and their derivatives<sup>a</sup></b>		
Isopropyl alcohol	0	0
Cetyl alcohol	2	2
Isocetyl alcohol	4	4
Oleyl alcohol	4	2
Stearyl alcohol	2	2
Sorbitol	0	0
Sorbitan laurate	1–2	1–2
Sorbitan oelate	3	0
Sorbitan stearate	0	0
Oleth-3	5	2
Oleth-5	3	2
Oleth-10	2	1
Oleth-20	1	0
<b>B. Effect of solvent on comedogenicity potential</b>		
	Organic solvent <sup>b</sup> (grades 0–5)	Sunflower oil (grades 0–5)
Caproic acid	0	2
Lauric acid	3	4
Palmitic acid	0	2
Stearic acid	0	2
Behenic acid	1	1
D&C Red 36	3 (in mineral oil)	0 (in PEG 400)

(Continued)

**Table 33.5** (Continued)

## C. Comparison of human back and rabbit ear comedogenicity scores

Material	Mean comedogenicity score	
	Rabbit <sup>c</sup>	Human
Acetylated lanolin alcohol	3	2
Coca butter	3	2
5% Crude coal tar <sup>d</sup>	3	3
Isopropyl myristate	1	0.4
Safflower oil	1	0
5% or 8% sulfur <sup>d</sup>	3	2
2.5% sulfur <sup>d</sup>	2	1.2
Hydrophilic ointment	0	0

<sup>a</sup>Scoring scale is 0 to 5.

<sup>b</sup>Ethyl ether or acetone.

<sup>c</sup>Comedogenicity scored on a 0 to 3 scale.

*n* = three rabbits or five humans.

<sup>d</sup>These test materials were diluted with hydrophilic ointment. All other test materials were used at full strength.

Source: From Refs. 73 and 74.

observable clinical signs. Von Krogh and Maibach proposed a cascade of increasing rigorous testing for contact urticaria (76). It must be stressed that this testing, especially invasive scratch or prick testing, should be carried out by an experienced physician who has resuscitation apparatus readily available.

#### Photoreactions

The interaction of UV radiation with certain ingredients can cause chemical changes that produce irritation or allergic reactions. Usually, products are tested only if they contain ingredients that absorb UV light. This includes sunscreens and fragrances, although fragrance ingredients that cause photoallergy and phototoxicity have been identified by RIFM and are not used by most lotion manufacturers. Predictive test methods involve application of the test material to the skin then exposure to UV radiation. A parallel site has the product applied but is not exposed to UV light. This accounts for normal irritation or sensitization.

#### USE TESTING TO ASSESS ADVERSE REACTIONS

It is apparent from the section above, that there are many causes of the adverse reactions that consumers describe as "irritation." In normal usage, any of these reactions may occur. The reaction rate depends not only the products' composition and the consumer's skin condition but also, on how the consumer uses the product. This last factor can only be determined by when a target consumer uses or misuses it the normal conditions. Frequently such tests are run on panels that exceed 100, as the adverse reaction rate is low. To interpret the data properly, it is important to be able to benchmark the results, either from historical data for similar products, or by including a standard, a commercially available product with a known rate of adverse reactions in the marketplace. For those panelists that do experience an adverse reaction, follow-up is appropriate. This may include a questionnaire to better understand the symptoms and their cause and in a few cases diagnostic testing. Diagnostic tests include exaggerated usage such as the repeated open application test (ROAT) and the provocative usage test

(77,78). For contact urticaria, von Krogh and Maibach (76) suggested a cascade of open application on normal skin then slightly affected skin, followed by open then occlusive patching on slightly or previously effected skin. Whealing or erythema and edema indicate contact urticaria. If indicated, diagnostic patch testing for suspected allergic reactions should be run. A dermatologist experienced in this issue should run all the diagnostic testing.

#### EYE IRRITATION

Accidental exposure of hand and body lotions to the eyes does occur, as a sizable minority of consumers uses these products on their faces. As with skin irritation, premarketing safety assessment has two major steps. First, a review of the ingredients' toxicological profiles—is this ingredient an eye irritant, and at what concentration will the ingredient be used. Second is testing. Traditionally, the Draize test in rabbits has been used to assess irritation potential. Recently this is supplemented and in many cases superseded by predictive, *in vitro* methods. These include the chorioallantoic membrane vascular assay (CAMVA) in hen's eggs, which models damage to the conjunctiva and the bovine corneal opacity and permeability test (BCOP), which models corneal damage. Cell culture is also used. Human test methods such as direct eye instillation under the direction of an ophthalmologist may be used, but these are more common for facial care products.

#### REFERENCES

1. Wall LM, Gebauer KA. Occupational skin disease in Western Australia. *Contact Dermatitis* 1991; 24:101-105.
2. Halkier-Sorensen L. Notified occupational skin diseases in Denmark. *Contact Dermatitis Supplement* 1 1996; 35:1-35.
3. Takano S, Yamanaka M, Okamoto K, et al. Allergens of lanolin: parts I and II. *J Soc Cosmet Chem* 1983; 34:99-125.
4. USP XXVI. Lanolin Monograph 2003; 26:1056-1058.
5. Ghadially R, Halkier-Sorensen L, Elias PM. Effects of petrolatum on stratum corneum structure and function. *J Am Acad Dermatol* 1992; 26:387-396.

6. Kligman AM. Regression method for assessing the efficacy of moisturizers *Cosmet Toilet* 1978; 93:27–35.
7. Elias PM, Brown BE, Ziboh VA. The permeability barrier in essential fatty acid deficiency: evidence for a direct role for linoleic acid in barrier function. *J Invest Dermatol* 1980; 74:230–233.
8. Prottey C, Hartop PJ, Press M. Correction of the cutaneous manifestations of essential acid deficiency in man by application of sunflower seed oil to the skin. *J Invest Dermatol* 1975; 64:228–234.
9. Froebe CL, Simion FA, Ohlmeyer H, et al. Prevention of stratum corneum lipid phase transition *in vitro* by glycerol—an alternative mechanism for skin moisturization. *J Soc Cosmet Chem* 1990; 41: 51–65.
10. Mattai J, Froebe CL, Rhein LD, et al. Prevention of model stratum corneum lipid phase transitions by cosmetic additives—differential scanning calorimetry, optical microscopy and water evaporation studies. *J Soc Cosmet Chem* 1993; 44:89–100.
11. Rawlings A, Harding C, Watkinson A, et al. The effect of glycerol and humidity on desosome degradation in stratum corneum. *Arch Dermatol Res* 1995; 287:457–464.
12. Braun O, Mallo P, Basset S. U.S. patent 7,462,363 B2, 2008.
13. Adams RM, Maibach HI. A five year study of cosmetic reactions. *J Am Acad Dermatol* 1985; 13:1062–1069.
14. Stiller MJ, Bartolone J, Stern R, et al. Topical 8% glycolic acid and 8% L-lactic acid creams for the treatment of photodamaged skin. *Arch Dermatol* 1996; 132:631–636.
15. Imokawa G, Asasaki S, Kawamata A, et al. Water retaining function in the stratum corneum and its recovery properties by synthetic pseudoceramides. *J Soc Cosmet Sci* 1989; 40:273–285.
16. Kornhauser A, Wei RR, Yamaguchi Y, et al. The effects of topically applied glycolic acid and salicylic acid on ultraviolet-induced erythema, DNA damage and sunburn cell formation in human skin. *J Dermatol Sci* 2009; 55:10–17.
17. Sah A, Mukherjee S, Wickett RR. Effects of product structure and formulation on delivery of AHA to skin. *J Soc Cosmet Chem* 1997; 48: 55–56.
18. Boisitis EK, Nole GE, Cheney MC. The refined regression method. *J Cutan Aging Cosmetic Dermatol* 1989; 1:155–163.
19. Prall JK, Theiler RF, Bowser PA, et al. The effectiveness of cosmetic products in alleviating a range of skin dryness conditions as determined by clinical and instrumental techniques. *Internat J Cosmet Sci* 1986; 8:159–174.
20. Grove GL. Skin surface hydration changes during a mini-regression test as measured *in vivo* by electrical conductivity. *Curr Ther Res* 1992; 52:556–561.
21. Appa Y, Hemingway L, Orth DS, et al. Poster Presentation at the 53rd Annual Meeting of the American Academy of Dermatology, 1995.
22. Highley DR, Savoyka VO, O'Neill JJ, et al. A stereomicroscopic method for the determination of moisturizing efficacy in humans. *J Soc Cosmet Chem* 1976; 27:351–363.
23. Simion FA, Babulak SW, Morrison BM, et al. Experimental method soap induced dryness in the absence of erythema. Scientific Exhibit in the 50th American Academy of Dermatology Annual Meeting, Dallas, Texas, 1991.
24. Zhai H, Maibach HI. Moisturizers in preventing irritant contact dermatitis: an overview. *Contact Dermatitis* 1998; 38:241–244.
25. Hannuksela A, Kinnunen T. Moisturizers prevent irritant dermatitis. *Acta Derm Venereol (Stockh)* 1992; 72:42–44.
26. Lodén M, Andersson A-C. Effect of topically applied lipids on surfactant-irritated skin. *Br J Dermatol* 1996; 134:215–220.
27. Simion FA, Abrutyn ES, Draelos ZD. Ability of moisturizers to reduce dry skin and irritation and to prevent their return. *J Cosmet Sci* 2005; 56:427–444.
28. Agner T, Held E. Skin protection programmes. *Contact Dermatitis* 2002; 46:253–256.
29. Frosch PJ, Kurte A. Efficacy of Barrier Creams (IV): the repetitive irritation test (RIT) with a set of 4 standard irritants. *Contact Dermatitis* 1994; 31:161–168.
30. Schentz E, Diepgen TL, Elsner P, et al. Multicentre study for the development of an *in vivo* model to evaluate the influence of topical formulations on irritation. *Contact Dermatitis* 2000; 42: 336–341.
31. Wigger-Alberti W, Caduff L, Burg G, et al. Experimentally induced chronic irritant dermatitis to evaluate the efficacy of protective creams *in vivo*. *J Am Acad Dermatol* 1999; 40:590–596.
32. Potts RO. Stratum corneum hydration: experimental techniques and interpretation of results. *J Soc Cosmet Chem* 1986; 37:9–33.
33. Kajs TM, Gartstein V. Review of the instrumental assessment of skin: effects of cleansing products. *J Soc Cosmet Chem* 1991; 42: 249–271.
34. Frosch PJ, Kligman AM, eds. *Non-invasive Methods for the Quantification of Skin Functions*. New York: Springer-Verlag, 1993.
35. Serup J, Jemec GBE, Grove GL, eds. *Handbook of Non-Invasive Methods and the Skin*. 2nd ed. Boca Raton: CRC Press, 2006.
36. Berardesca E, Elsner P, Wilhelm K-P, et al. eds. *Bioengineering of the Skin: Methods and Instrumentation*. Boca Raton: CRC Press, 1995.
37. Schatz H, Altmeyer PJ, Kligman AM. Dry skin and scaling evaluated by D-Squames and image analysis. In: Serup J, Jemec GME eds. *Handbook of Non-Invasive Methods and the Skin*. Boca Raton: CRC Press, 1995:153–157.
38. Simion FA, Witt PS, Rau AH, et al. Stratum corneum cellular damage produced by surfactants during dry skin induction. Poster presentation at the American Academy of Dermatology.
39. Pierard GE, Arrese JE, Rodriguez C, et al. Effects of softened and unsoftened fabrics on sensitive skin. *Contact Dermatitis* 1994; 30: 286–291.
40. Tronnier H, Wiebusch M, Heinrich U, et al. Surface evaluation of living skin. *Adv Exp Med Biol* 1999; 455:507–516.
41. Matts PJ, Fink B, Grammer K, et al. Color homogeneity and visual perception of age, health, and attractiveness of female facial skin. *J Am Acad Dermatol* 2007; 57:977–984.
42. Egawa M, Tagami H. Comparison of depth profiles of water and water binding substances in stratum corneum determined *in vivo* by Raman spectroscopy between cheek and volar forearm skin: effects of age, seasonal changes and artificial forced hydration. *Br J Dermatol* 2008; 158:251–260.
43. Crowther JM, Sieg A, Blenkiron P, et al. Measuring the effects of topical moisturizers on changes in stratum corneum thickness, water gradients and hydration *in vivo*. *Br J Dermatol* 2008; 159:567–577.
44. Morrison BM, Scala DD. Comparison of instrumental methods of skin hydration. *J Toxicol Cut Occular Toxicol* 1996; 15:305–314.
45. Loden M, Lindberg M. The influence of a single application of different moisturizers on the skin capacitance. *Acta Derm Venereol (Stockh)* 1991; 71:79–82.
46. Agache PG. Twistometry measurement of skin elasticity. In: Serup J, Jemec GBE, eds. *Handbook of Non-Invasive Methods and the Skin*. Boca Raton: CRC Press, 1995:319–328.
47. Barel AO, Courage W, Clarys P. Suction methods for measurement of skin mechanical properties: the Cutometer. In: Serup J, Jemec GME, eds. *Handbook of Non-Invasive Methods and the Skin*. Boca Raton: CRC Press, 1995:335–340.
48. Elsner P. Skin elasticity. In: Berardesca E, Elsner P, Wilhelm K-P, et al. eds. *Bioengineering and the Skin: Methods and Instrumentation*. Boca Raton: CRC Press, 1995:53–64.
49. Omata S, Terunuma Y. New tactile sensor like the human hand and its application. *Sensors and Actuators* 1992; 35:9–15.
50. Meilgaard M, Civielle GV, Carr BT. *Sensory Evaluation Techniques*. Pub. CRC Press, 1987.
51. Smithies RH. Moisturization claims challenged through the NAD. *J Toxicol Cut Ocular Toxicol* 1992; 11:205–211.
52. Frosch PJ, Kligman AM. A method of appraising the stinging capacity of topically applied substances. *J Soc Cosmet Chem* 1977; 28:197–210.
53. Basketter DA, Griffiths HA. A study of the relationship between susceptibility to skin stinging and skin irritation. *Contact Dermatitis* 1993; 29:185–189.

54. Phillips L, Steinberg M, Maibach HI, et al. A comparison of rabbit and human skin response to certain irritants. *Toxicol Appl Pharmacol* 1972; 21:369-382.
55. Bowman JP, Berger RS, Mills OH, et al. The 21-day human cumulative irritation test can be reduced to 14 days without loss of sensitivity. *J Cosmet Sci* 2003; 54, 443-449.
56. Nilsson E, Mikaelsson B, Andersson S. Atopy, occupation and domestic work as risk factors for hand eczema in hospital workers. *Contact Dermatitis* 1985; 13:216-223.
57. Freeman S, Maibach HI. Study of irritant contact dermatitis produced by repeated patch testing with sodium lauryl sulfate and assessed by visual methods, transepidermal water loss and Laser Doppler velocimetry. *J Am Acad Dermatol* 1988; 19:496-501.
58. Kligman AM. The invisible dermatoses. *Arch Dermatol* 1991; 127: 1375-1382.
59. Lee CH, Maibach HI. Study of cumulative contact irritant contact dermatitis in man utilizing open application on subclinically irritated skin. *Contact Dermatitis* 1994; 30:271-275.
60. Frosch PJ, Kligman AM. The chamber scarification test for irritancy. *Contact Dermatitis* 1976; 2:314-324.
61. de Groot AC, Nater JP, van der Hende R, et al. Adverse effects of cosmetics and toiletries: a retrospective study in a general population. *Int J Cosmet Sci* 1988; 9:255-259.
62. Christensen M, Kligman AM. An improved procedure for conducting lactic acid stinging tests on facial skin. *J Cosmet Sci* 1996; 47:1-11.
63. Zug KA, Warshaw EM, Fowler JF, et al. Patch-test results of the North American contact dermatitis group 2005-2006. *Dermatitis* 2009; 20:149-160.
64. Marks JG, Belsito DV, DeLeo VA, et al. North American Contact Dermatitis Group patch test results for the detection of delayed type hypersensitivity to topical allergens. *J Am Acad Dermatol* 1998; 38:911-918.
65. Marks JG, Belsito DV, DeLeo VA, et al. North American Contact Dermatitis Group patch test results 1998-2000. *Am J Contact Dermatitis* 2003; 14:59-62.
66. Warshaw EM, Belsito DV, DeLeo VA, et al. North American Contact Dermatitis Group patch test results, 2003-2004 study period. *Dermatitis* 2008; 19:129-136.
67. Jackson EM. Paraben paradoxes. *Am J Contact Dermatitis* 1993; 4: 69-70.
68. Api AM, Basketter DA, Cadby PA, et al. Dermal sensitization quantitative risk assessment (QRA) for fragrance ingredients. *Regul Toxicol Pharmacol* 2008; 52:3-23.
69. Marzulli FN, Maibach HI. Contact allergy predictive testing in humans. In: Marzulli FN, Maibach HI, eds. *Dermatotoxicology*. 4th ed. New York: Hemisphere, 1991:415-439.
70. Kligman AM, Epstein W. Updating the maximization test for identifying contact allergens. *Contact Dermatitis* 1975; 1:231-239.
71. Morris WE, Kwan SC. Use of the rabbit ear model in evaluating the comedogenic potential of cosmetic material. *J Soc Cosmet Chem* 1983; 34:215.
72. Mills OH, Kligman AM. Human model for assessing comedogenic substances. *Arch Dermatol* 1982; 118:903-905.
73. Fulton JE, Jr. Comedogenicity and irritancy of commonly used ingredients in skin care products. *J Soc Cosmet Chem* 1989; 40: 321-333.
74. Mills OH, Kligman AM. Comedogenicity of sunscreens. *Arch Dermatol* 1982; 118:417-419.
75. Strauss JS, Jackson EM. American Academy of Dermatology Invitational Symposium on comedogenicity. *J Am Acad Dermatol* 1989; 20:272-277.
76. von Krogh C, Maibach HI. The contact urticaria syndrome. *Semin Dermatol* 1982; 1:59-66.
77. Zhai HB, Maibach HI. Use tests: ROAT (repeated open application test)/PUT (provocative use test) an overview. *Contact Dermatitis* 2000; 43:1-3.
78. Fischer LA, Voelund A, Andersen KE, et al. The dose response relationship between the patch test and ROAT and the potential use for regular purposes. *Contact Dermatitis* 2009; 61:201-208.



## Anticellulite products and therapies

Enzo Berardesca and Manuela Carrera

### INTRODUCTION

The term cellulite, first used in the 1920s by Alquier and Paviot, defines a localized lipodystrophic disease, which affects more women than men. Nodular liposclerosis, edematofibrosclerotic panniculopathy, panniculosis, and gynoid lipodystrophy are some of the other names proposed over the last decades instead of cellulite. The pathophysiological aspects of cellulite are still poorly cleared. Many predisposing factors seem to influence cellulite onset, including gender, heredity, race, body weight, and age. Hormones and impairment of both microvascular and lymphatic circulation are considered the most important etiologic factors. Cellulite usually develops in particular anatomic sites such as lateral thighs and buttocks. The histopathological modifications that characterize cellulite involve the different "operational units" of the fatty tissue: the matricial-interstitial unit, the microcirculatory unit, the neuro-vegetative unit, and the energy-fatty unit. These alterations are accountable for the padded and orange peel appearance of the affected areas and induce irregular body profile. Cellulite represents an heartfelt esthetic problem for millions of women around the world. Various systemic and topical products as well as numerous medical procedures have been developed to resolve cellulite, very often with poor results and little scientific basis.

### AETIOPATHOGENESIS

In 1922, two French doctors, Alquier and Paviot, were the first to describe cellulite as a nonphlogistic dystrophy of the mesenchymal tissue, which implied accumulation of interstitial liquids. They suggested that the disorder was a reaction to stimuli of different origin: infectious, traumatic, toxic, etc. Since then, many contrasting theories have been expressed to explain the aetiopathogenesis of cellulite, which is currently often considered a physiological phenomenon, especially in Anglo-Saxon countries.

Among the different hypothesis, the theory proposed by Curri has gained approvals and remains one of the most popular ones (1). According to Curri, cellulite begins with alterations of the precapillary arteriolar sphincter, as described by Merlen, which induce capillary ectasia, increased capillovenular permeability with accumulation of interstitial liquid and consequent intercellular edema. Edema provokes fibroblast activation and proliferation, which cause hyperpolymerization of glycosaminoglycans in the connective matrix of the subcutaneous tissue. This phenomenon increases hydrophilicity of the intercellular matrix as well as the interstitial osmotic pressure. These alterations induce tissue hypoxia, which results in collagen production and damaged adipocytes. Anisopoikilocytotic adipocytes are hence surrounded by thickened

fibrosclerotic septae; groups of adipocytes gradually form micronodules and subsequently macronodules.

Around 85% of postpuberal women suffer from cellulite, independently of their weight. This is due to the anatomy of the subcutaneous fat, which is constituted by two layers divided by a superficial fascia. The areolar layer is located just underneath the dermis; in this layer adipocytes are large and arranged vertically. In the lamellar layer, which is the deeper one, adipocytes are small arranged horizontally. If weight increases, the lamellar layer enlarges. When cellulite occurs it is the superficial part of hypodermis that tends to protrude into the dermis. The areolar layer is thicker in women than in men and is under the control of estrogen.

Hormonal factors seem to play a significant role in cellulite onset as well as in its evolution. Cellulite affects prevalently women, appears after puberty and worsens during pregnancy and contraceptive therapy; therefore cellulite is greatly influenced by estrogen. Estrogen acts on adipocyte increasing lipogenesis and hence causing adipocyte hypertrophy and anisopoikilocytosis, it promotes fibroblast proliferation and alterations in glycosaminoglycans and collagen, leading to fibrosclerosis. Insulin, prolactin and thyroid hormones are also involved in the pathophysiology of cellulite. Furthermore, recent investigations on the adipose organ have highlighted that adipocytes release several substances, which act in an endocrine or paracrine way as well as some so-called adipokine (2). On the basis of the new knowledge, it is clear that adipose tissue is not a passive organ but rather a dynamic organ able to interact with and regulate other cells such as endothelial cells.

Cellulite development also depends on predisposing factors such as genetic, nutritional, lifestyle, and pharmacological factors. Sex is the most important genetic predisposing factor. On the basis of histological examinations, Nürnberger and Muller have noticed that a female subcutaneous tissue presents some anatomical peculiarities such as fibrous bands whose course is perpendicular to the skin's surface and which could be responsible of the "hill" profile of the dermo-hypodermic border whereas in men the fibrous septa present a different disposition, more oblique with reference to the skin (3). Furthermore, a recent study performed by means of magnetic nuclear resonance imaging (MRI) has confirmed that women with cellulite have constitutional characteristics of fibrous interlobular bands, which induce bigger and radial fat chambers (4). Caucasian women are more frequently affected by cellulite than Asian or Black women. Genetic influences the number and the sensitivity of hormones receptors on adipocytes as well as the tendency to circulatory insufficiency. Nutritional factors are very important. As hyperinsulinemia stimulates lipogenesis, excessive intake of fats and carbohydrates contributes to cellulite onset and worsening. But although adiposity is linked to cellulite, MRI has

demonstrated that, among women with body mass index over 30, there are women who do not manifest cellulite at all. Salt favors hydric retention and alcohol stimulates lipogenesis. Sedentary lifestyle contributes to cellulite as it is associated with ponderal increase and decreased activity of the muscular pumping in the lower limbs with consequent venous stasis. The muscular pumping activity is also influenced by the habit to wear tight clothes and high heeled shoes. Among drugs, estrogens, antihistamines, and  $\beta$ -blockers have shown to play a role in cellulite's development.

## CLASSIFICATION

On the basis of clinical and histological modifications that occur in the subcutaneous tissue, four stages of cellulite are distinguishable (5).

### Stage I

In the first stage, the patient may be asymptomatic or only manifest a pale and pasty skin. Histologically, we can observe a thicker areolar layer, increased capillary permeability, anisopoikilocytotic adipocytes, ectasic capillaries, and lipoeidema.

### Stage II

Clinical alterations are not clearly evident at rest but only after skin pinching or muscular contraction we can observe an orange peel appearance, with decreased skin temperature and elasticity. Histologically, the fibril network, which surrounds adipocytes, appears hypertrophic; there is an important microvessel dilatation, and there are microhemorrhagies.

### Stage III

In this phase, clinical changes are appreciable at rest with the characteristic orange peel aspect. On palpation, we can notice small lumps, hypoelasticity, and decreased skin temperature. This clinical picture histologically corresponds to anisopoikilocytotic adipocytes encapsulated in micronodules, neofibrillogenesis, and dilation of small veins.

### Stage IV

The clinical characteristics of the stage III are more evident, in particular there are macronodules due to the agglomeration of many micronodules. In this stage, cellulite may be painful because of the compression of the nerves by the nodules.

According to skin consistency, we can distinguish four types of cellulite: hard, flaccid, edematous, and mixed (6). Hard cellulite is characteristic of teenagers and young women who regularly practice sport; at rest skin appears firm and compact and orange peel becomes evident only after pinching. On the contrary, inactive subjects usually show flaccid cellulite, which is associated to muscular hypotonia. In the edematous form, lower limbs are globally enlarged and patients complaint sense of heaviness, cramps, and swelling.

## NONINVASIVE TECHNIQUES TO EVALUATE CELLULITE

The variety of anticellulite products and professional (surgical or not) approaches to treat cellulite is quite huge: ranging from topical products to oral regimens, from manual or mechanical massages to garments, we can find out many and many strategies

to contrast such a condition, a borderline one with pathology. In general, the efficacy of cellulite treatments is often debated and objective studies are needed to claim support. Furthermore, it is very difficult to investigate cellulite by bioengineering methods.

### Thigh Circumference Measurements

This traditional measure indicates the reduction of thigh circumference, which can be due to both the reduction of edema, and the effect on the fatty layer. It is recorded on hips, ankles and thighs as follows:

1. Hip: The tape measure is positioned around the hips, putting it finally on the superanterior iliac crest.
2. Thigh: The tape measure is placed around the thigh, marking the site of interest.
3. Ankle: The tape measure is placed around the ankle, exactly above the malleolar bone (7).

### Ultrasonography

Ultrasound is used to study the thickness and the quality of the connective tissue and the edematous component of cellulite. Frequencies between 10 and 15 MHz should be chosen for skin examination. With higher frequencies it becomes more difficult to view in depth (8).

### Laser Doppler Flowmetry

Laser Doppler flowmetry (LDF) is an optical technique used to evaluate skin microcirculation, which provides information on blood flow and erythema.

The method consists of a Ne-He laser source of 632 nm wavelength applied to the skin via a small probe. The incident radiation enters the skin and is scattered and reflected by nonmoving tissue components and by mobile red blood cells encountered as the radiation penetrates to a depth of 1 to 1.5 mm. A portion of the scattered and reflected incident radiation exits the skin and is collected by a second optical fiber that carries the light back to a photodetector where it is converted to an electrical signal. Stationary skin tissue reflects and back-scatters light with the same frequency as the incident source, while moving erythrocytes reflect the frequency-shifted radiation. The shift increases with increasing erythrocytes speed. The LDF extracts the frequency-shifted signal and derives an output proportional to the flux of erythrocytes of the blood flow. LDF is a reliable method to estimate cutaneous microcirculation (9).

### Thermography

Anticellulite products are meant to increase local skin blood flow. By increasing the blood flow, they increase the local skin temperature. Thermography is an electrooptical method for the imaging of temperature. The current technology used is based on the detection of the infrared radiation emitted by the skin. A conventional color thermogram uses a spectral color range, where blue is cold and redwhite is hot. Intermediary temperatures are shown as shades of green, yellow, orange, etc. (10).

### Plicometry

The technique implies the use of the plicometer, a device that allows to evaluate the thickness of cutaneous plicae or folds, which is possible to calculate the percentage of fat in human

body. The measurement is usually performed on the thigh, on a defined point, which can be determined by measuring the half distance between the iliac crest and the center of the knee as reference points.

During measurements, the leg is relaxed. All measurements are performed in standard conditions, which guarantee reliability and suitability of collected data.

### Magnetic Resonance Imaging (11)

Amongst in vivo skin imaging methods, MRI is the most recent approach, being of high interest not only for its ability to distinguish structures at a submillimetre scale, but also for its ability to describe the physiology of the different skin layers through the measurement of their intrinsic MR parameters. High spatial resolution MRI allows to differentiate the different skin departments, epidermis, dermis, and hypodermis, giving new and interesting opportunities for the evaluation of anti-cellulite treatments. Actually some authors (4) found that changes in skin architecture with cellulite can be well visualized by that method, pointing out clearly in the images the skin fat layers beneath the dermis and down to the level of muscles. Also, the diffuse pattern of extrusion of underlying adipose tissue into dermis is clearly imaged, and was found to correlate with cellulite grading. In turn, other researchers (12) applying such a technique characterized the topography of the dermo-hypodermal junction, and the three-dimensional architecture of the subcutaneous fibrous septae, giving as more clear frame of skin condition in areas affected by cellulite.

### Therapies

#### Pharmacological Agents

Several proximate principles have been employed, topically, systemically, or transdermally, in attempt to contrasting the different pathophysiological aspects of cellulite. Notwithstanding, only a few scientific studies proving their real efficacy have been published.

Methylxanthines such as theobromine, theophylline, aminophylline, and caffeine,  $\beta$ -adrenergic agonists such as isoproterenol and adrenaline and  $\alpha$ -antagonists such as yohimbine, piperoxan, and phentolamine, represent drugs with a lipolytic effect. Among these, topical aminophylline has demonstrated to be the most effective one but the best results are obtained applying aminophylline together with yohimbine and isoproterenol (13). The use of coenzyme A and L-carnitine may contribute to improve the effects of the above mentioned drugs as they induce the discharge of free fatty acids.

A 2.8-mm decrease in subcutaneous fat thickness has been observed after a month of application of a product containing caffeine, horsechestnut, ivy, algae, bladderwrack, plankton, butcherbroom, and soy (14). Extracts from *Centella asiatica* is active either on connective tissue either on micro-circulation and they are commonly used orally and topically. In particular 60 mg of Asiatic *Centella* once a day for 90 days induces reduction of adipocytes' dimensions (15).

Distante et al. have performed a prospective, longitudinal double-blind designed study aimed to test a plant complex on the basis of seed extracts of grape (*Vitis vinifera*), *Ginkgo biloba*, Asiatic *Centella*, *Mellilotus* (*Mellilotus officinalis*), fucus vesiculosus, fish oil, and borage oil. Data obtained from these trials have demonstrated that the oral intake of the mixture of plant extracts leads to significant improvement of cellulite (16).

A four-week oral intake of peroxisome proliferator-activated receptors (PPAR) agonists have demonstrated to reduce subcutaneous fat thickness in mice (17).

Actually there is no FDA-approved dietary supplement for cellulite treatment.

### Massage Treatment

Bayrakci et al. (18) have investigated the effects of mechanical massage, manual lymphatic drainage, and connective tissue manipulation techniques on cellulite. They have reported improvement in all groups treated with a decrease of thigh circumference and fat thickness. This study confirms previous data obtained by Lucassen et al. (19) who have monitored the effectiveness of electromechanical massage device by ultrasound imaging. A "smoothing" of the dermis-hypodermis interface has been observed but the improvement was transitory as the result regresses after the end of the treatments.

### Endermologie

LPG endermologie is an electromechanical handheld massage device, designed by Louis Paul Guitay, a French engineer and approved by FDA for cellulite treatment. The machine consists in two rollers and a vacuum chamber. The rollers rhythmically fold and unfolds skin and subcutaneous tissue whereas the vacuum impresses a negative pressure. In the few published studies the results obtained highlight that LPG induces fat mobilization and redefines body profile. In a recent trial performed on 33 women with cellulite grades 1 to 3, treated with LPG twice weekly for 15 sessions, Gülec (20) observed a circumference reduction in all patients but only 15% of the subjects had a reduction of cellulite grade.

### Optical Devices

Velasmoth (Syneron Medical Ltd., Yokneam, Israel) combines negative tissue massage, radio frequency (RF) and a 700-nm infrared light (IR), it has approved by FDA for the treatment of cellulite. The mechanical massage improves micro-circulation and facilitates lymphatic drainage whereas RF and IR heat the tissue thus inducing collagen contraction and neo-collagenesis. Improvement is usually obtained after eight or more treatments, delivered on a twice-weekly basis. Monthly maintenance treatment is recommended. Results decline within six months post treatment (21).

TriActive (Cynosure, Inc., Chelmsford, Massachusetts, U.S.) combines a 810-nm diode laser, contact cooling, suction and massage. It represents another FDA-approved device to contrasting cellulite and has shown to be as effective as Velasmoth in a randomized, comparative, prospective clinical study in which patients were treated twice a week for six weeks. Bruising was the only reported side-effect, occurring globally in about 55% of the patients (22).

Goldberg et al. have investigated the use an unipolar RF device (Alma Lasers, Buffalo Grove, Illinois, U.S.), which delivers a high-frequency electromagnetic radiation at 40 MHz inducing heating of the tissue. Good results have been obtained with a treatment regimen of six every-other-week sessions and benefits were persistent for the following six months (23).

More recently, a new bipolar RF system emitting variable frequencies, called automatic multifrequency and low impedance (AMPLI) RF has been experimented for cellulite in the buttocks in a multicenter study. Enrolled subjects underwent

one treatment per week for 12 sessions. An improvement in body profile was observed. With reference with the other types of RF devices already used, the AMPLI RF technology has the advantage of a continuous emission of different frequencies with a consequent progressive heating, an homogeneous thermal damage, sparing epidermidis (24).

Manuskiatti et al. have tested a Tripollar RF device (Regen, Pollogen Ltd., Tel Aviv, Israel) for cellulite reduction. This novel system employs a three-electrode technology to deliver the RF. Patients were treated once a week for eight sessions. Good results were reached in terms of reduction of circumference and better appearance of cellulite (25).

### Surgical Subcision

The surgeon tears the connective bands that ties the dermis to the fascia by means of a needle (26). This mechanism is also exploited by liposculpture, which, moreover, reduces local adiposity.

### Mesotherapy

This method that delivers drugs directly into the dermis of the affected areas, by means of several injections, was conceived by Pistor in 1958 and is commonly employed since 1964. Despite its popularity, mesotherapy is lacking in scientific published supports. Several drugs are used such as aminophylline, enzymes, minerals, L-carnitine, and, recently, phosphatidylcholine.

### REFERENCES

- Curri SB. Adiposità localizzata e pannicolopatia edematofibrosclerotica. 1990 Sepem Ed., Milano.
- Havel PJ. Update on adipocyte hormones: regulation of energy balance and carbohydrate/lipid metabolism. *Diabetes* 2004; 53 (suppl 1):S143-S151.
- Nürnberg F, Müller G. So-called cellulite: an invented disease. *J Dermatol Surg Oncol* 1978; 4(3):221-229.
- Mirrashed F, Sharp JC, Krause V, et al. Pilot study of dermal and subcutaneous fat structures by MRI in individuals who differ in gender, BMI, and cellulite grading. *Skin Res Technol* 2004; 10 (3):161-168.
- Curri SB. Las panniculopatie de estasis venosa: diagnostico clinic e instrumental. Hausmann, Barcelona, 1991.
- Rossi AB, Vergnanini AL. Cellulite: a review. *J Eur Acad Dermatol Venereol* 2000; 14(4):251-262. Review.
- Smith PW. Cellulite treatments: snake oils or skin science. *Cosmet Toilet* 1995; 110:61-70.
- Serup J. Skin imaging techniques. In: Berardesca E, Elsner P, Wilhelm K, eds. *Bioengineering and the Skin: Methods and Instrumentation*. Boca Raton: CRC Press, 1995:65-79.
- Bernardi L, Berardesca E. Measurements of skin blood flow by laser Doppler flowmetry. In: Berardesca E, Elsner P, Wilhelm K, eds. *Bioengineering and the Skin: Methods and Instrumentation*. Boca Raton: CRC Press, 1995:13-28.
- Sherman RA, Woerman AL, Arstetter KW. Comparative effectiveness of videothermography, contact thermography, and infrared beam thermography for scanning relative skin temperature. *J Rehabil Res Dev* 1966; 33:377-386.
- Querleux B. Magnetic resonance imaging and spectroscopy of skin and subcutis. *J Cosmet Dermatol* 2004; 3:156-161.
- Querleux B, Cornillon C, Jolivet O, et al. Anatomy and physiology of subcutaneous adipose tissue by in vivo magnetic resonance imaging and spectroscopy: relationships with sex and presence of cellulite. *Skin Res Technol* 2002; 8:118-124.
- Greenway FL, Bray GA. Regional fat loss from the thigh in obese women after adrenergic modulation. *Clin Ther* 1987; 9(6):663-669.
- Buscaglia DA, Conte ET. The treatment of cellulite with methyl-xanthine and herbal extract based cream: an ultrasonographic analysis. *Cosmet Dermatol* 1996; 9:30-10.
- Hachem A, Borgoin JY. Etude anatomo-clinique des effets de l'extrait titré de *Centella asiatica* dans la lipodystrophie localisée. *La Méd Prat* 1979; 12(suppl 2):17-21.
- Distante F, Bacci PA, Carrera M. Efficacy of a multifunctional plant complex in the treatment of the so-called 'cellulite': clinical and instrumental evaluation. *Int J Cosmet Sci* 2006; 28(3):191-206.
- Tsuzuki T, Kawakami Y, Nakagawa K, et al. Conjugated docosa-hexaenoic acid inhibits lipid accumulation in rats. *J Nutr Biochem* 2006; 17(8):518-524; [Epub October 25, 2005].
- Bayrakci Tunay V, Akbayrak T, Bakar Y, et al. Effects of mechanical massage, manual lymphatic drainage and connective tissue manipulation techniques on fat mass in women with cellulite. *J Eur Acad Dermatol Venereol* 2010; 24(2):138-142; [Epub July 13, 2009].
- Lucassen GW, van der Sluys WLN, van Herk JJ, et al. The effectiveness of massage treatment on cellulite as monitored by ultrasound imaging. *Skin Res Technol* 1997; 3:154-160.
- Güleç AT. Treatment of cellulite with LPG endermologie. *Int J Dermatol* 2009; 48(3):265-270.
- Alster TS, Tehrani M. Treatment of cellulite with optical devices: an overview with practical considerations. *Lasers Surg Med* 2006; 38(8):727-730. Review.
- Nootheti PK, Magpantay A, Yosowitz G, et al. A single center, randomized, comparative, prospective clinical study to determine the efficacy of the VelaSmooth system versus the Triactive system for the treatment of cellulite. *Lasers Surg Med* 2006; 38(10):908-912.
- Goldberg DJ, Fazeli A, Berlin AL. Clinical, laboratory, and MRI analysis of cellulite treatment with a unipolar radiofrequency device. *Dermatol Surg* 2008; 34(2):204-209; discussion 209; [Epub December 17, 2007].
- Van der Lugt C, Romero C, Ancona D, et al. A multicenter study of cellulite treatment with a variable emission radio frequency system. *Dermatol Ther* 2009; 22(1):74-84.
- Manuskiatti W, Wachirakaphan C, Lektrakul N, et al. Circumference reduction and cellulite treatment with a TriPollar radiofrequency device: a pilot study. *J Eur Acad Dermatol Venereol* 2009; 23(7):820-827; [Epub April 8, 2009].
- Hexsel DM, Mazzucco R. Subcision: a treatment for cellulite. *Int J Dermatol* 2000; 39(7):539-544.

# Therapy of telangiectasia and varicose veins and their complications

Robert A. Weiss and Margaret A. Weiss

## INTRODUCTION

One of the most commonly treated cosmetic disorders in dermatology includes telangiectatic webs or spider veins. The methods of treatment most commonly employed by the dermatologic surgeon include sclerotherapy and lasers. For larger varicose veins, dermatologic surgeons employ sclerotherapy with the newest improvement of foamed detergent-sclerosing agents, ambulatory phlebectomy and endovenous occlusion, and ablation by intravascular radiofrequency or laser energy.

Sclerotherapy, which consists of the intravascular introduction of a sclerosing substance, is the most frequently utilized process. Sclerotherapy is actually endovenous chemoablation with subsequent fibrosis and concomitant vein wall collagen dissolution. The term "sclerotherapy" gained acceptance during the 19th century and has never changed. In the United States, sclerotherapy gained wide acceptance in the early 1990s and is regarded as a highly effective treatment for telangiectasias as well as veins of all sizes (1,2). It also serves as an effective addition to surgical techniques such as ambulatory phlebectomy for saphenous tributaries (3,4) and endovenous obliteration of refluxing saphenous veins (5,6). Knowledge of venous anatomy and physiology, principles of venous insufficiency, methods of diagnosing venous malfunction, uses and actions of sclerosing solutions, and proper use of compression are essential elements of successful venous therapy.

## EPIDEMIOLOGY

Bulging varicose veins and unsightly "roadmap" telangiectatic webs affect millions of patients, and the number affected is increasing every year as the population ages. Telangiectasias comprise one of the most common of cosmetic complaints, affecting up to 50% of women, while larger varicose veins affect up to 40% of the population (7,8). Varicose veins may cause significant morbidity including chronic stasis dermatitis, ankle edema, spontaneous bleeding, superficial thrombophlebitis, recurrent cellulitis, lipodermatosclerosis, and skin ulceration on the ankle and foot.

The incidence of varicose veins increases with each decade of life. Increased incidence has led to increased demand for treatment of varicose and telangiectatic veins as the average age of the U.S. population grows. While 41% of women in the fifth decade have varicose veins, this number rises to 72% in the seventh decade (9). Statistics for men are similar with 24% incidence in the fourth decade, increasing to 43% by the seventh decade. Six million workdays per year may be lost because of complications of varicose veins including stasis dermatitis, cellulitis, and ulceration (10).

## HISTORICAL ASPECTS

In the second century A.D., Galen proposed tearing out the veins with hooks, a precursor to the modern day technique of ambulatory phlebectomy originated by Swiss dermatologist Robert Muller in the late 1960s. Primitive stripping and cauterization, however, were practiced by Celsus, while ligation was mentioned by Antyllus (30 A.D.).

In 1851 Pravaz attempted sclerotherapy with ferric chloride using his new invention, the hypodermic syringe. The foundation of modern sclerotherapy can be traced to World War I when both Linser and Sicard noticed the sclerosing effect of intravenous injections used to treat syphilis that often resulted in vein sclerosis. Tournay greatly refined the sclerotherapy technique in Europe and wrote the gold standard of textbooks. French physicians were leaders in the field of vein diagnosis and treatment, which evolved into the subspecialty of phlebology. It was not until 1946, when a safe sclerosant, Sotradecol (sodium tetradecyl sulfate) had been tested and described that sclerotherapy began to be seriously studied in the United States (11).

Another key to success and acceptance of the treatment of varicose veins by sclerotherapy was the addition of compression. The most significant contributions were European with Sigg and Orbach in the 1950s and Fegan in the 1960s emphasizing the importance of combining external compression immediately following injections. Starting in the 1980s, Duffy promoted the technique in the United States among dermatologists and advocated the use of polidocanol (POL) and hypertonic saline as safe and effective sclerosing solutions (12). The first endovenous obliteration technique utilizing radiofrequency, designed as a substitute for ligation and stripping of the greater saphenous vein, was researched and pioneered by dermatologic surgeons (6). It has now become accepted as the standard for treatment of saphenous vein reflux (13). Utilization began in Europe in 1998 on saphenous vein incompetence, and the technique was made available in the United States in March 1999. Goldman's first American textbook of sclerotherapy (now in its fourth edition) integrated the world's phlebology literature, introduced new sclerosing solutions, and validated dermatology's claim to expertise in vein treatment (14). Several additional textbooks by dermatologic surgeons have now firmly established phlebology, which includes the diagnosis and treatment of spider and varicose veins firmly within the sphere of dermatology (15,16).

## VENOUS ANATOMY AND PHYSIOLOGY: THE KEY TO CHOOSING THE RIGHT TECHNIQUE

The superficial venous system consists of three primary territories: great saphenous vein, small saphenous vein, and subdermic lateral venous system. Because of gravitational

hydrostatic pressure, sequential retrograde breakdown of venous valve function often follows a leak at one point leading to propagation of a varicosity or spider vein. All veins regardless of their size contain valves (17). Increased diameter between valve leaflets with failure to oppose properly caused by genetically weak venous wall or venous valve structure may initiate these events (8). Calf muscle pump pressure plus gravitational hydrostatic forces are transmitted directly via the incompetent perforating vein or communicating veins to the surface veins. Venous pressure may reach as high as 300 mmHg in the cutaneous venules with the patient erect. Transmission of pressure may result in venular dilatation over a wide area of skin including the formation of telangiectatic webs.

When present in significant quantity, the volume of blood sequestered and stagnant in reticular veins and associated telangiectatic webs (particularly of the lateral venous system) may cause enough distention to produce symptoms (18). Symptoms are relieved by the wearing of support hose or with rest and elevation of the legs. Prolonged standing or sitting worsens symptoms. The size of the vessels causing moderately severe symptoms may be as small as 1 to 2 mm in diameter. Sclerotherapy has been reported to yield an 85% reduction in these symptoms as well as superb cosmetic results (18).

### CONTRAINDICATIONS TO TREATMENT OF SPIDER VEINS

A high rate of recurrence for sclerotherapy is commonly seen when reflux originates at the major saphenous junctions. When reflux exists at the saphenofemoral junction, this must be dealt with prior to treatment of distal varicosities or telangiectasias. Since the goal of sclerotherapy and other treatments is to eliminate reflux at its origin, the goal of noninvasive diagnostic evaluation is to reveal the primary source of reverse flow. The techniques of endovenous occlusion by radiofrequency or laser have been developed to address reflux occurring at the termination point of the saphenous veins. Over a decade of experience has shown that radiofrequency or endovenous ablation is as effective as the surgical techniques of ligation and stripping to eliminate saphenous and associated varicose veins (13,19).

Previous urticaria or suspected allergy to a sclerosing agent should serve as a relative contraindication to use of that particular sclerosing agent. A history of deep venous thrombosis (DVT) or previous trauma to the leg (e.g., auto accident) should preclude sclerotherapy until adequately evaluated by Duplex ultrasound. Venous treatment is contraindicated in a bedridden patient since ambulation is important for minimizing risks of thrombosis. Similarly, patients under general anesthesia for nonrelated procedures should not undergo simultaneous sclerotherapy. Severely restricted arterial flow to the legs necessitates postponement of vein treatment. During hot summer months, heat-induced vasodilatation and inability to comply with wearing of compression hose may also require postponement of treatment.

Pregnancy is no longer considered a contraindication to sclerotherapy, extremely painful or bleeding varices may be treated even in the last trimester in our experience. Endovenous techniques may be employed to treat refluxing saphenous veins in pregnancy. However, treatment is typically postponed since many varicosities and telangiectasias will spontaneously clear within one to six months postpartum. Obesity should be considered a relative contraindication since maintaining adequate external compression is difficult.

## TREATMENT TECHNIQUES Sclerotherapy or Endovenous Chemoablation Techniques

### General Principles

Progression from proximal to distal regions will focus initial treatment on vessels most likely to be proximal pressure sources. Thus, a basic principle of treatment is to begin at the largest (reflux sources) and progress to the smallest varicosities. Sclerotherapy of telangiectasias is approached by combined injection of visibly connected reticular veins, venulectasias, and telangiectatic webs or networks.

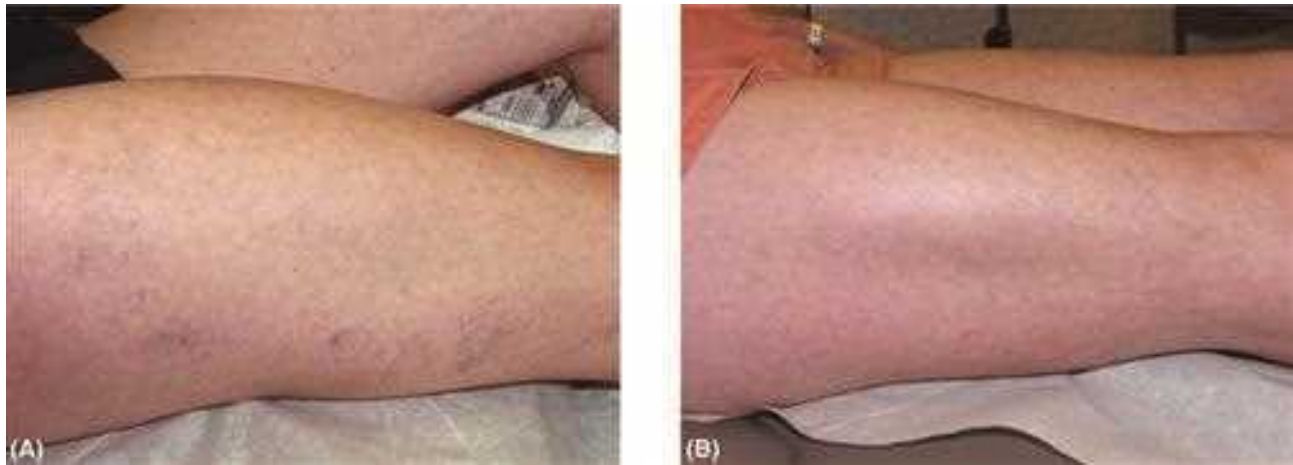
Reticular veins are treated only after all sources of reflux from major varicosities have been treated by sclerotherapy and/or surgery. When no clear feeder vessel is seen or identified by duplex ultrasound, transillumination (Veinlite, 3Gen, Dana Point, California, U.S.) is another method that may be used to identify the "feeding" reticular vein. When unable to locate an associated reticular vein, then the point at which the telangiectasias begin to branch out is the site at which to begin injection. Injection of telangiectasias is simultaneously performed with injection of reticular veins in the hopes of decreasing the number of treatments (20).

### TECHNIQUE OF SCLEROTHERAPY Liquid Sclerotherapy

To reduce side effects for treatment of telangiectasia, use of a liquid sclerosant rather than foamed sclerosant is advantageous (see later). The American dermatology technique of sclerotherapy has been described in detail by Duffy and Goldman (12,21). The sclerotherapy tray is prepared with the necessary equipment including a 30-gauge needle, bent to an angle of 10° to 30° with the bevel up, that is placed on the skin so that the needle is parallel to the skin surface. A 3 cc syringe filled with 1.5 to 2 cc of solution is held between the index and middle fingers while the fourth and fifth finger support the syringe against the leg in a fixed position facilitating accurate penetration of the vessel (Fig. 35.1). The nondominant hand is used to stretch the skin around the needle and may offer additional support for



**Figure 35.1** Position of the hands for sclerotherapy. While the dominant hand holds the syringe and creates a platform with the fifth digit, the nondominant hand stretches the skin and acts as a support for the needle hub so that fine changes in position are permitted.



**Figure 35.2** Typical results following sclerotherapy of telangiectasia. (A) Treatment with 0.1% STS. (B) Excellent clinical results at four-month follow-up.

the syringe. Magnifying lenses or operating loops on the order of 1.5 to 3 $\times$  are recommended to aid in cannulation of the smallest telangiectasias.

The initial treatment of telangiectatic webs begins with lowest possible concentration that will cause a telangiectasia to sclerose over a period of one to six months post injection. This typically is 0.1% sodium tetradecyl sulfate (STS), 0.2% POL, or 72% glycerin in water. When ineffective sclerosis occurs judged at a subsequent visit, the concentration but *not* the volume per site of sclerosing solution is increased. Post-treatment compression consists of graduated 20 to 30 mmHg support hose for two weeks for telangiectasia associated with reticular veins and OTC 15 mmHg compression for telangiectasias only. Treatment intervals vary between physicians, but allowing four to eight weeks between treatments allows time for resorption of treated telangiectasias and therefore helps to minimize the number of necessary sessions. Typical results are shown in Figure 35.2.

### Sclerosing Solutions

Sclerosing solutions have been classified into groups based on chemical structure and effect: hyperosmotic, detergent and corrosive agents (chemical toxins—salts, alcohols, and acid or alkaline solutions). The distinct advantage of detergent agents is the ability to foam these solutions to use for larger varicosities. Table 35.1 summarizes the sclerosing agents.

#### *Hypertonic Saline*

This is still a commonly employed solution (only in the United States) in spite of the extreme pain on injection and relatively low efficacy in vessels over 0.4 mm. We recommend against using this as a sclerosing solution. Used at a concentration of 23.4% (HS), a theoretical advantage of HS is its total lack of allergenicity when unadulterated. HS has been commonly used in various concentrations from 10% to 30%, with occasional addition of heparin, procaine, or lidocaine. Additional agents typically provide no benefit. Therefore, HS is used either unadulterated or diluted to 11.7% with sterile water for smaller telangiectasias (22).

With hypertonic solutions, damage of tissue adjacent to injection sites may easily occur. Skin necrosis may be produced by extravasation at the injection site particularly when injecting very close to the skin surface. HS is not one of our favorite solutions for this reason. Injection of hyaluronidase into sites of extravasation may significantly reduce the risks of skin necrosis with HS, although this has not been demonstrated in human clinical applications (23).

Hypertonic saline and dextrose (HSD) (Sclerodex, Omega Laboratories Ltd., Montreal, Canada). HSD is a viscous mixture of dextrose 250 mg/mL, sodium chloride 100 mg/mL, propylene glycol 100 mg/mL, and phenethyl alcohol 8 mg/mL. HSD is a relatively weak sclerosant for local treatment of small vessels, with a total volume of injection not to exceed 10 mL per visit with 0.1 to 1 mL per injection site. HSD is marketed predominately in Canada. Although a slight burning sensation occurs, pain is far less than with HS. Efficacy has been seen by us in over 5000 patients with excellent results for treatment of telangiectasias and small associated reticular veins.

#### *Polidocanol*

The detergent-based POL (Aethoxysklerol, Kreussler & Co., Wiesbaden-Biebrich, West Germany), a urethane compound, was originally developed as an anesthetic, but was found to have the property of sclerosing small diameter vessels after intradermal injection. POL contains hydroxypolyethoxydodecane dissolved in distilled water with 5% ethanol as a stabilizer. First used as a sclerosing agent in the late 1960s in Germany, POL is popular worldwide for smaller vessels because of painless injection and lowest incidence of cutaneous necrosis with intradermal injection. Lower concentrations of POL were initially suspected to have a lower incidence of hyperpigmentation than HS or STS, but recent clinical trials indicate that a significant percentage of hyperpigmentation also occurs (24). Australian comparison studies have preferred POL over STS with increased efficacy with fewer complications (24). POL is currently being evaluated by the FDA for marketing in the United States and is anticipated to be available in the United

**Table 35.1** Comparison of Sclerosing Agents

Sclerosing solution	Category	Advantages	Disadvantages	Vessels treated	Concentrations (reduce concentrations for foamed solution by 50%)
Sodium tetradecyl sulfate (STS)	Detergent	May be foamed Low incidence of allergic reaction when used with Latex-free syringe	May cause skin breakdown at higher concentrations	All sizes	0.1–0.2% telangiectasias 0.2–0.5% reticular 0.5–1.0% varicose 1.0–3.0% axial varicose
Polidocanol (POL)	Detergent	May be foamed Forgiving with intradermal injection	May inadvertently be injected into arteriole without pain	Small to medium	0.25–0.5% telangiectasias 0.5–1.0% reticular 1.0–3.0% varicose
Hypertonic saline (HS)	Hyperosmolar	Not allergic	Ulcerogenic Painful to inject	Small	23.4–11.7% telangiectasias 23.4% reticular
Hypertonic saline + Dextrose (HSD)	Hyperosmolar	Less painful than HS	Relatively weak sclerosant	Small	Undiluted—telangiectasias Undiluted—reticular
Sodium morrhuate	Detergent	None	Allergic reactions highest	Small	Undiluted—telangiectasias Undiluted—reticular
Glycerin (72% glycerin with 0.5% lidocaine)	Chemical irritant	Treats matting Low incidence of pigmentation	Very weak sclerosant	Smallest	Undiluted to ½ strength—telangiectasias
Polyiodinated iodine (Varigloban)	Chemical irritant	Powerful for largest veins	Void in iodine allergic patients	Largest	1–2% for up to 5 mm veins 2–6% for the largest veins

States in 2010. It will be the first new sclerosing solution introduced in the United States since 1946.

*Sodium Tetradecyl Sulfate*

STS (Fibrovein, STD Pharmaceuticals, United Kingdom; Thrombovar, Omega Labs, Montreal, Canada) is a long-chain fatty acid salt with strong detergent properties and is a highly effective sclerosing agent used worldwide. Approved for use in the United States since 1946, it has been popular with vascular surgeons since the 1960s and first described for use in telangiectasias in the 1970s. A relatively high incidence of postsclerosis pigmentation was reported at inappropriately high doses (1% STS). More appropriate concentrations for superficial telangiectasias are 0.1% to 0.2%. Other concentrations are 0.2% to 0.5% in reticular veins or small varicosities (1–3 mm diameter), and 0.5% to 3% in larger varicosities related to major sites of valvular reflux. Recent use of foamed STS indicates that half the concentration may be utilized when the solution is frothed with air (see later)

*Sodium Morrhuate*

Sodium morrhuate (Scleromate, Palisades Pharmaceuticals, Inc., Tenafly, New Jersey, U.S.) is a 5% solution of the salts of saturated and unsaturated fatty acids in cod liver oil. Approximately 10% of its fatty acid composition is unknown and use is limited by reports of fatalities secondary to anaphylaxis (14). Although sodium morrhuate is approved by the FDA for the sclerosis of varicose veins, use in treatment of telangiectasias is not common due to the caustic qualities with potential for cutaneous necrosis and higher risks of allergy. This agent is reserved primarily for sclerosis of esophageal varices.

*Chemical Irritants*

The chemical irritants include polyiodinated iodine (very caustic) and chromated glycerin (very weak) and are believed to have a direct toxic effect on the endothelium. After injection of

polyiodinated iodine salt, the endothelium near the site of injection is destroyed within seconds. The corrosive action is limited because of rapid inactivation by blood proteins. At the sites of endothelial destruction, the chemical can penetrate further and diffuse into deeper layers of the vessel wall causing further destruction. These agents are not commercially cleared by the U.S. FDA.

A preparation of 72% glycerin diluted 2:1 with 1% lidocaine can be prepared by local compounding pharmacies. Glycerin without the chromate salt may work primarily by osmotic injury. A commercial glycerin product has been reported to give a lower incidence of inflammation and subsequent pigmentation in smaller telangiectasias (25). In our experience in over 10,000 patients over the last five years, the 72% glycerin solution was the most effective at eliminating telangiectatic matting and resistant telangiectasias. It is particularly effective in treating smaller residual telangiectasias with a greatly reduced incidence of matting and hyperpigmentation. Glycerin cannot be foamed.

*Foam Sclerotherapy*

Detergent agents such as POL and STS may be mixed with air to create a foamed sclerosing solution (26–30). Typically air is added at a ratio of one part solution to three to four parts air. Agitation is performed by rapid transfer from syringe to syringe via an IV stopcock yielding a foamy substance as shown injected into these vessels (Fig. 35.3). The advantages for treatment of larger vessels include: (i) by displacing blood in the vein, the highest concentration of sclerosant is always contacting vessel wall; (ii) the total amount of sclerosant injected is greatly reduced; (iii) there is great persistence of sclerosant with very slow washout, and finally this can be used as a contrast agent under Duplex ultrasound. An illustration of the persistence of foam is seen in Figure 35.3. Recently, it was reported with POL that the foamed version is far more potent on varicose veins than the nonfoamed of equal concentration (31).





**Figure 35.3** Foam sclerotherapy (A) Injection of foam. (B) Persistence of foamed sclerosant at 2 minutes post-injection.

## SIDE EFFECTS AND COMPLICATIONS OF SCLEROTHERAPY

### Postsclerotherapy Hyperpigmentation

Postsclerosis pigmentation is defined as the appearance of increased visible pigmentation along the course of a treated vein of any size. Initially perivascular hemosiderin deposition and not increased melanin production causes this appearance (32). However, after several weeks to months, the hemosiderin is replaced by melanin. The reason for persistence of pigmentation is unknown. The incidence of pigmentation is related to dilution and type of sclerosing agent as well as diameter of treated vessel (33). Pigmentation incidence ranges from 11% to 30% using HS (18), 11% to 30% with POL (12,34), and up to 30% with STS. The incidence of pigmentation may be reduced in varicose veins by expressing the dark, viscous blood thought to be a liquefied coagulum or intravascular hematoma that may accumulate one to four weeks following sclerotherapy. For those patients highly susceptible to pigmentation, such as African American patients, the use of glycerin as a sclerosant agent is highly recommended.

Pigmentation clears in 70% within six months but rarely persists for greater than a year (33,35). Attempts to hasten resolution of pigmentation have been mostly unsuccessful as the pigment is dermal hemosiderin and not epidermal melanin. Bleaching agents, exfoliants such as trichloroacetic acid or phenol, cryotherapy, various lasers, and intense pulsed light have achieved limited success (36,37). The Q-switched ruby laser has been found to be the most consistently effective for treatment of post-sclerosis pigmentation (38). Our experience with multiple wavelengths of Q-switched lasers indicate that ruby, alexandrite, or Nd:YAG Q-switched lasers may be successfully applied to clear the pigmentation more rapidly.

### Telangiectatic Matting

Telangiectatic matting is defined as the appearance of groups of new, fine (<0.2 mm diameter) telangiectasias surrounding or replacing a previously treated area in a blush-like manner. A retrospective analysis of over 2000 patients reports an incidence of 16% in patients treated with HS and POL (39). Resolution

usually occurs spontaneously within a 3- to 12-month period with 70% to 80% spontaneous resolution within the first six months (40).

Matting may also occur as a result of trauma to the leg, in association with pregnancy or hormonal therapy or in scars around previous sites of surgical stripping. Predisposing factors include predilection for certain areas of the leg, such as the medial lower thigh, obesity, hormonal therapy with estrogen, family history, and a longer history of telangiectasias (39). The relative risk factor for development of telangiectatic matting is 3.17 times greater for female patients taking hormonal supplements (41). Successful treatment of matting with pulsed dye laser (PDL) is reported to be accompanied by temporary hyperpigmentation (42). The use of enhanced visualization with a cross-polarized light source (Syris Scientific, LLC, Grey, Massachusetts, U.S.) has been found to assist injection of sclerosing solution into telangiectatic matting. Treatment is often not required since matting will resolve spontaneously except when caused by a source of reflux superiorly.

### Cutaneous Necrosis/Ulceration

Cutaneous ulceration may occur with all sclerosing solutions in spite of the most skilled technique. Unavoidably, a tiny amount of sclerosing solution may be left along the needle tract as the needle is withdrawn. Sclerosing solution may also leak out into the skin through the small puncture sites of vessel cannulation. The varicose vein may have a fragile, thin wall, with the injection causing rapid injury leading to sudden unexpected rupture with perivascular accumulation of sclerosant. Additionally, injection may inadvertently occur into a small arteriole associated with telangiectatic varicosities with resultant necrosis and ulceration.

When the dermatologic surgeon recognizes that extravasation has occurred, the risk for necrosis can be minimized by injecting normal saline in a ratio of 10:1 into the extravasation site. Extensive massage of small subcutaneous blebs to spread the trapped sclerosing agent as quickly as possible will minimize prolonged blanching of the area. We have found that the application of topical 2% nitroglycerine paste applied

immediately to the suspected extravasation site greatly reduces the risks of necrosis but will not always prevent it.

#### *Superficial Thrombophlebitis*

This complication is most commonly mistaken for the normal nodular fibrosis (endosclerosis) that occurs with proper sclerotherapy. After sclerotherapy, a nontender, nonpigmented, nonerythematous fibrotic cord may normally be palpable along the course of a treated 4 to 8 mm vein. This frequent finding is due to a liquefied intravascular hematoma with surrounding vein wall sclerosis and is not a thrombus. In contrast, superficial thrombophlebitis is characterized clinically by a very tender, indurated, linear erythematous swelling. Incidence of superficial thrombophlebitis is quite variable estimated at 1% to 0.01% following sclerotherapy (43), although some report that the incidence is higher than typically reported (44). Treatment consists of leg elevation and/or compression and regular administration of aspirin or other nonsteroidal anti-inflammatory drugs. Extension of superficial thrombophlebitis into the deep system is extremely rare so that aggressive anticoagulation is not the usual course of therapy.

#### *Pulmonary Embolism*

Pulmonary emboli probably occur from extension of a superficial thrombus into the deep venous system. Evidence of extension from superficial thrombus to deep thrombophlebitis should be treated promptly by anticoagulation. The incidence of pulmonary embolism has been associated with injection of large quantities of sclerosant at a single site. The incidence is extremely low with less than 1 in 40,000. We have not seen this complication in treatment of over 20,000 patients.

#### *Arterial Injection*

This dreaded medical emergency is fortunately extremely rare. Classic warning signs include immediate intense pain far beyond the normal discomfort at the initiation of injection, although leakage of sclerosant into the arterial circulation may present in an atypical fashion. Continuous intense burning pain with immediate bone white cutaneous blanching over an area of several square centimeters is the usual initial sign. Progression to a sharply demarcated cyanosis within minutes is typical for arterial injection. Emergency treatment involves immediate application of ice, attempts to flush the inadvertently injected artery with normal saline and/or heparin, injection of 3% procaine to inactivate STS, and vascular surgery consultation for intravenous anticoagulation.

A major clinical problem is that arterial injection may rarely not be accompanied by any pain or cutaneous signs. The atypical cases are suspected to arise from arterio-venous (A-V) malformations that allow sclerosant to enter the arterial system via the venous system (45). This is most commonly seen in the popliteal fossa. Arterial injection may lead to wide areas of skin necrosis and damage to subcutaneous tissue and muscle that take months to heal.

## **MODERN MINIMAL SURGICAL APPROACHES FOR VARICOSE VEINS**

### **Endovenous Occlusion Techniques**

When it has been determined by ultrasound that the originating point of reverse flow or reflux is the greater saphenous vein, endovenous radiofrequency or laser techniques are now utilized.

The efficacy for RF elimination of reflux is 90% at 2 years (46) and is now known to give similar results at 10 years of follow-up (47). This method involves the placement of a catheter within the varicose vein through a small puncture or incision. The catheter is threaded up to the saphenofemoral junction typically under duplex ultrasound guidance. Following placement of tumescent local anesthesia between the vein and the skin and or in a perivenous location, energy is applied as the catheter is slowly withdrawn. This results in a collagen shrinkage of the vein wall accompanied by complete occlusion (19). Midterm studies suggest a very favorable comparison to traditional ligation and stripping with far less morbidity without the risks of general anesthesia (46). Typical results are shown in Figure 35.4.

The other endovenous technique involves the use of laser energy. This technique is termed endovenous laser treatment or EVLT. Very similar to RF occlusion, this technique involves the placement of a laser fiberoptic via a small puncture. Wavelengths presently utilized are 810, 940, and 980 nm. The newest wavelength, 1320 nm, that is absorbed only by water has been shown to provide superior results (48). The primary problem with present wavelengths absorbed by hemoglobin is the requirement for blood for laser absorption (19). This leads to increased risks of bruising and pain. A wavelength absorbed by water only appears to eliminate these side effects.

### **Surgical Ligation and Limited Stripping**

For larger varicose veins, particularly originating from an incompetent valve at the saphenofemoral junction, ligation of the greater saphenous vein with short stripping of its proximal half in the thigh is the traditional surgical method but has been replaced by endovenous ablation by RF or laser. After proximal ligation without stripping of the saphenous vein, varicography has shown persistent mid-thigh perforator incompetence in 34%, a patent portion of saphenous vein in 54%, and residual or recurrent femoral-saphenous communication in 80% (49). High ligation combined with sclerotherapy or with varicosity excision was inferior to high ligation and stripping of the saphenous vein (50). The technique of ligation and stripping has virtually been replaced by endovenous techniques.

### **Ambulatory Phlebectomy**

This technique, originally described by Robert Muller and further refined by another Swiss dermatologist (Albert-Adrien Ramelet), involves the use of tiny incisions through which the varicose vein is removed by a small hook (51,52). This safe, outpatient local anesthesia technique allows removal of almost any varicose vein except the saphenofemoral or saphenopopliteal junction. Ambulatory phlebectomy is used for primary or secondary branches of saphenous-related varicosities. Areas or veins that are resistant to sclerotherapy (axial) are particularly indicated for ambulatory phlebectomy (Fig. 35.4). Risks minimized compared with sclerotherapy are deep venous thrombosis, post-sclerotherapy pigmentation, skin necrosis, and superficial phlebitis. In many cases, larger varicose veins coexist with smaller reticular veins and associated telangiectatic webs. It is reasonable to treat larger varicose veins by various surgical techniques and follow up with sclerotherapy of the remaining reticular networks.



**Figure 35.4** Ambulatory phlebectomy of a large truncal varicose vein. (A) Before. (B) After AP and endovenous RF occlusion of the greater saphenous vein. It is important to eliminate the source of reflux into this vein concomitant with the ambulatory phlebectomy of this primary branch arising from the greater saphenous vein.

### Lasers and Light Sources

New trends for improved results with lasers and light sources for spider veins include longer wavelengths, larger spot sizes, and cooling to protect the skin. The first report of 1064 nm Nd:YAG laser indicated that 75% improvement was possible after a single treatment at three months (53). These findings were confirmed and mechanism of action explained as heat-induced vessel damage and subsequent fibrosis (54). Recent reports also indicate effectiveness of 940-nm diode laser (55). Shorter wavelengths used in the past, like pulsed dye laser (PDL), are useful on leg veins fine telangiectasia like telangiectatic matting especially with longer pulse durations up to 40 milliseconds. A broadband, noncoherent pulsed light (IPL) has been reported to improve 70% of patients responding with up to five treatments per region (56). In our practice, the vast majority of laser treatments are performed using 1064 nm Nd:YAG in the millisecond domain on isolated telangiectasias, sclerotherapy-resistant telangiectasias, ankle telangiectasias, and suspected arterio-venous malformations. We also use PDL for fine telangiectasias up to 0.8 mL, especially using an elliptical optical spot at 10 milliseconds or longer, which can be oriented along the long axis of telangiectasia of the leg (57).

### SUMMARY

Phlebology is an integral part of dermatologic surgery. The method of endovascular chemoablation or sclerotherapy is the gold standard for treatment of telangiectasias and small varicosities. A supplemental technique for telangiectasias is laser. Larger veins that originate from saphenous reflux require endovenous RF or laser techniques for effective treatment. These techniques replace traditional stripping and ligation. Primary or secondary branches of saphenous varicosities can

be treated by ambulatory phlebectomy or the newest technique of foam sclerotherapy.

### REFERENCES

1. Weiss RA, Weiss MA, Goldman MP. Physicians' negative perception of sclerotherapy for venous disorders: review of a 7-year experience with modern sclerotherapy. *South Med J* 1992; 85:1101–1106.
2. Weiss RA, Goldman MP. Advances in sclerotherapy. *Dermatol Clin* 1995; 13(2):431–445.
3. Goldman MP, Weiss RA, Bergan JJ. Diagnosis and treatment of varicose veins—a review (review). *J Am Acad Dermatol* 1994; 31(3pt 1):393–413.
4. Weiss RA, Weiss MA. Ambulatory phlebectomy compared to sclerotherapy for varicose and telangiectatic veins: indications and complications. *Adv Dermatol* 1996; 11:3–17.
5. Weiss RA. Endovenous techniques for elimination of saphenous reflux: a valuable treatment modality. *Dermatol Surg* 2001; 27(10): 902–905.
6. Goldman MP. Closure of the greater saphenous vein with endoluminal radiofrequency thermal heating of the vein wall in combination with ambulatory phlebectomy: preliminary 6-month follow-up. *Dermatol Surg* 2000; 26(5):452–456.
7. Biegeleisen K. Primary lower extremity telangiectasias relationship of size to color. *Angiology* 1987; 38:760–768.
8. Golledge J, Quigley FG. Pathogenesis of varicose veins. *Eur J Vasc Endovasc Surg* 2003; 25(4):319–324.
9. Engel A, Johnson ML, Haynes SG. Health effects of sunlight exposure in the United States: Results from the first national health and nutrition examination survey, 1971–1974. *Arch Dermatol* 1988; 124:72–79.
10. Lofgren KA. Varicose veins: their symptoms, complications, and management. *Postgrad Med* 1979; 65(6):131–139.
11. Cooper WM. Clinical evaluation of sotradecol, a sodium alkyl sulfate solution, in the injection therapy of varicose veins. *Surg Gynecol Obstet* 1946; 83:647–652.

12. Duffy DM. Small vessel sclerotherapy: an overview. *Adv Dermatol* 1988; 3:221-242.
13. Ravi R, Trayler EA, Barrett DA, et al. Endovenous thermal ablation of superficial venous insufficiency of the lower extremity: single-center experience with 3000 limbs treated in a 7-year period. *J Endovasc Ther* 2009; 16(4):500-505.
14. van HE, Liasis N, van RB, et al. The development of valvular incompetence after deep vein thrombosis: a 7 year follow-up study with duplex scanning. *Eur J Vasc Endovasc Surg* 1996; 12(3): 295-299.
15. Weiss RA, Feied CF, Weiss MA. *Vein Diagnosis and Treatment: A Comprehensive Approach*. New York: McGraw-Hill, 2001.
16. Sadick NS. *Manual of Sclerotherapy*. New York: Lippincott Williams and Wilkins, 2000.
17. Scultetus AH, Villavicencio JL, Rich NM. Facts and fiction surrounding the discovery of the venous valves. *J Vasc Surg* 2001; 33(2): 435-441.
18. Weiss RA, Weiss MA. Resolution of pain associated with varicose and telangiectatic leg veins after compression sclerotherapy. *J Dermatol Surg Oncol* 1990; 16:333-336.
19. Weiss RA. Comparison of endovenous radiofrequency versus 810 nm diode laser occlusion of large veins in an animal model. *Dermatol Surg* 2002; 28(1):56-61.
20. Weiss RA, Weiss MA. Painful telangiectasias: diagnosis and treatment. In: Bergan JJ, Weiss RA, Goldman MP, eds. *Varicose Veins and Telangiectasias: Diagnosis and Treatment*. 2nd ed. St. Louis: Quality Medical Publishing, Inc., 1999:389-406.
21. Goldman MP, Bennett RG. Treatment of telangiectasia: a review. *J Am Acad Dermatol* 1987; 17:167-182.
22. Sadick NS. Sclerotherapy of varicose and telangiectatic leg veins. Minimal sclerosant concentration of hypertonic saline and its relationship to vessel diameter [see comments]. *J Dermatol Surg Oncol* 1991; 17:65-70.
23. Zimmet SE. The prevention of cutaneous necrosis following extravasation of hypertonic saline and sodium tetradecyl sulfate. *J Dermatol Surg Oncol* 1993; 19:641-646.
24. Conrad P, Malouf GM, Stacey MC. The australian polidocanol aethoxysklerol study results at 2 years. *Dermatol Surg* 1995; 21(4): 334-336.
25. Georgiev M. Postsclerotherapy hyperpigmentations. Chromated glycerin as a screen for patients at risk (a retrospective study). *J Dermatol Surg Oncol* 1993; 19:649-652.
26. Belcaro G, Cesarone MR, Di Renzo A, et al. Foam-sclerotherapy, surgery, sclerotherapy, and combined treatment for varicose veins: a 10-year, prospective, randomized, controlled, trial (VEDICO trial). *Angiology* 2003; 54(3):307-315.
27. Frullini A, Cavezzi A. Sclerosing foam in the treatment of varicose veins and telangiectases: history and analysis of safety and complications. *Dermatol Surg* 2002; 28(1):11-15.
28. Frullini A. New technique in producing sclerosing foam in a disposable syringe. *Dermatol Surg* 2000; 26(7):705-706.
29. Sadoun S, Benigni JP. Bonnes pratiques cliniques et mousse de sclérosant: propositions pour une étude randomisée contrôlée, prospective, multicentrique, comparative, en aveugle, sur le traitement sclérosant par la mousse d'aetoxisclérol à 0,20%. *Phlebologie* 1999; (3):291-298.
30. Tessari L, Cavezzi A, Frullini A. Preliminary experience with a new sclerosing foam in the treatment of varicose veins. *Dermatol Surg* 2001; 27(1):58-60.
31. Rabe E, Otto J, Schliephake D, et al. Efficacy and safety of great saphenous vein sclerotherapy using standardised polidocanol foam (ESAF): a randomised controlled multicentre clinical trial. *Eur J Vasc Endovasc Surg* 2008; 35(2):238-245 [Epub November 7, 2007].
32. Goldman MP, Kaplan RP, Duffy DM. Postsclerotherapy hyperpigmentation: a histologic evaluation. *J Dermatol Surg Oncol* 1987; 13: 547-550.
33. Weiss RA, Weiss MA. Incidence of side effects in the treatment of telangiectasias by compression sclerotherapy: hypertonic saline vs. polidocanol. *J Dermatol Surg Oncol* 1990; 16:800-804.
34. Goldman PM. Sclerotherapy for superficial venules and telangiectasias of the lower extremities. *Dermatol Clin* 1987; 5:369-379.
35. Georgiev M. Postsclerotherapy hyperpigmentations: a one-year follow-up. *J Dermatol Surg Oncol* 1990; 16:608-610.
36. Thibault P, Wlodarczyk J. Postsclerotherapy hyperpigmentation. The role of serum ferritin levels and the effectiveness of treatment with the copper vapor laser. *J Dermatol Surg Oncol* 1992; 18:47-52.
37. Goldman MP. Postsclerotherapy hyperpigmentation. Treatment with a flashlamp-excited pulsed dye laser. *J Dermatol Surg Oncol* 1992; 18:417-422.
38. Tafazzoli A, Rostan EF, Goldman MP. Q-switched ruby laser treatment for postsclerotherapy hyperpigmentation. *Dermatol Surg* 2000; 26(7):653-656.
39. Davis LT, Duffy DM. Determination of incidence and risk factors for postsclerotherapy telangiectatic matting of the lower extremity: a retrospective analysis. *J Dermatol Surg Oncol* 1990; 16:327-330.
40. Goldman MP, Sadick NS, Weiss RA. Cutaneous necrosis, telangiectatic matting, and hyperpigmentation following sclerotherapy. etiology, prevention, and treatment (review). *Dermatol Surg* 1995; 21(1):19-29.
41. Weiss MA, Weiss RA. Efficacy and side effects of 0.1% sodium tetradecyl sulfate in compression sclerotherapy of telangiectasias: comparison to 1% polidocanol and hypertonic saline. *J Dermatol Surg Oncol* 1991; 17:90-91.
42. Goldman MP, Fitzpatrick RE. Pulsed-dye laser treatment of leg telangiectasia: with and without simultaneous sclerotherapy. *J Dermatol Surg Oncol* 1990; 16:338-344.
43. Goldman MP. Sclerotherapy treatment for varicose and telangiectatic leg veins. In: Coleman WP, Hanke CW, Alt TH, et al. eds. *Cosmetic Surgery of the Skin*. Philadelphia: B.C. Decker, 1991:197-211.
44. Feied CF. Deep vein thrombosis: the risks of sclerotherapy in hypercoagulable states. *Semin Dermatol* 1993; 12:135-149.
45. Bergan JJ, Weiss RA, Goldman MP. Extensive tissue necrosis following high-concentration sclerotherapy for varicose veins. *Dermatol Surg* 2000; 26(6):535-541.
46. Weiss RA, Weiss MA. Controlled radiofrequency endovenous occlusion using a unique radiofrequency catheter under duplex guidance to eliminate saphenous varicose vein reflux: a 2-year follow-up. *Dermatol Surg* 2002; 28(1):38-42.
47. Nijsten T, van den Bos RR, Goldman MP, et al. Minimally invasive techniques in the treatment of saphenous varicose veins. *J Am Acad Dermatol* 2009; 60(1):110-119.
48. Goldman MP, Mauricio M, Rao J. Intravascular 1320-nm laser closure of the great saphenous vein: a 6- to 12-month follow-up study. *Dermatol Surg* 2004; 30(11):1380-1385.
49. Corbett CR, Runcie JJ, Lea Thomas M, et al. Reasons to strip the long saphenous vein. *Phlebologie* 1988; 41:766-769.
50. Neglen P. Treatment of varicosities of saphenous origin: comparison of ligation, selective excision, and sclerotherapy. In: Bergan JJ, Goldman MP, eds. *Varicose Veins & Telangiectasias: Diagnosis and Management*. St. Louis: Quality Medical Publishing, Inc., 1993:148-165.
51. Ramelet AA. Muller phlebectomy. A new phlebectomy hook. *J Dermatol Surg Oncol* 1991; 17:814-816.
52. Ramelet AA. Le traitement des telangiectasies: indications de la phlebectomie selon muller. *Phlebologie* 1995; 47(4):377-381.
53. Weiss RA, Weiss MA. Early clinical results with a multiple synchronized pulse 1064nm laser for leg telangiectasias and reticular veins. *Dermatol Surg* 1999; 25(5):399-402.
54. Sadick NS, Prieto VG, Shea CR, et al. Clinical and pathophysiologic correlates of 1064-nm Nd:Yag laser treatment of reticular veins and venulectasias. *Arch Dermatol* 2001; 137(5):613-617.
55. Kaudewitz P, Klovekorn W, Rother W. Effective treatment of leg vein telangiectasia with a new 940 nm diode laser. *Dermatol Surg* 2001; 27(2):101-106.
56. Goldman MP, Eckhouse S. Photothermal sclerosis of leg veins. ESC Medical Systems, LTD Photoderm VL Cooperative Study Group [see comments]. *Dermatol Surg* 1996; 22(4):323-330.
57. Galeckas KJ. Update on lasers and light devices for the treatment of vascular lesions. *Semin Cutan Med Surg* 2008; 27(4):276-284.

## Management of hirsutism and hypertrichosis

Ralph M. Trüeb

### INTRODUCTION

The queen [of Sheba] was brought before him, and when she saw the king [Solomon] sitting in his glass house, she thought within herself that the king sat on water, and so proceeded to draw up the hem of her dress so that she could pass over without getting wet. The king then saw her legs that they were full of hair, and when the queen had sat down beside him, he said unto her, "Thy beauty is the beauty befitting women, but thy hairs are the hairs befitting men. Hair on a man's body is comely, but uncomely on a woman's." Now the king greatly desired her beauty, but was taken aback by the hair on her legs, and so it was that he devised a method by which unwanted hairs may be removed, that is, by taking an admixture of lime and water and orpiment [arsenic trisulfide], which the king himself discovered and made known its usage abroad, calling it *neskasir*. When the queen had bathed herself that night in its solution, the hair on her legs fell off, and she found favor in the eyes of the king (from the Midrash Book of Proverbs).

Throughout the history of civilized mankind, overgrowth of hair has been of significant concern, the object of superstition and mystery, as well as of cosmetic and medical interest. Excessive hair may cause cosmetic embarrassment, resulting in a significant emotional burden, particularly if extensive. Sometimes the complaint of excess hair may pose a vexing problem for nonspecialized physicians, who tend to trivialize the complaint, though an individual's perception of abnormality is important in determining whether or not medical care is sought. Besides significant racial and ethnic differences in normal hair growth patterns, the role of society is to set the threshold level for "normality," which is much determined by advertisement for cosmetic treatments. With the advent of the effective laser epilation devices this increasingly also applies to the perception of excess hair by men.

No single method of hair removal is appropriate for all body locations or patients, therefore patients should be adequately advised of the available treatment modalities for temporary or permanent hair removal. The method adopted for removal of unwanted hair will depend on the cause, the character, area and amount of excessive hair growth, as well as on the age of the patient, and personal preference.

### CAUSES OF EXCESSIVE HAIR

#### Hirsutism

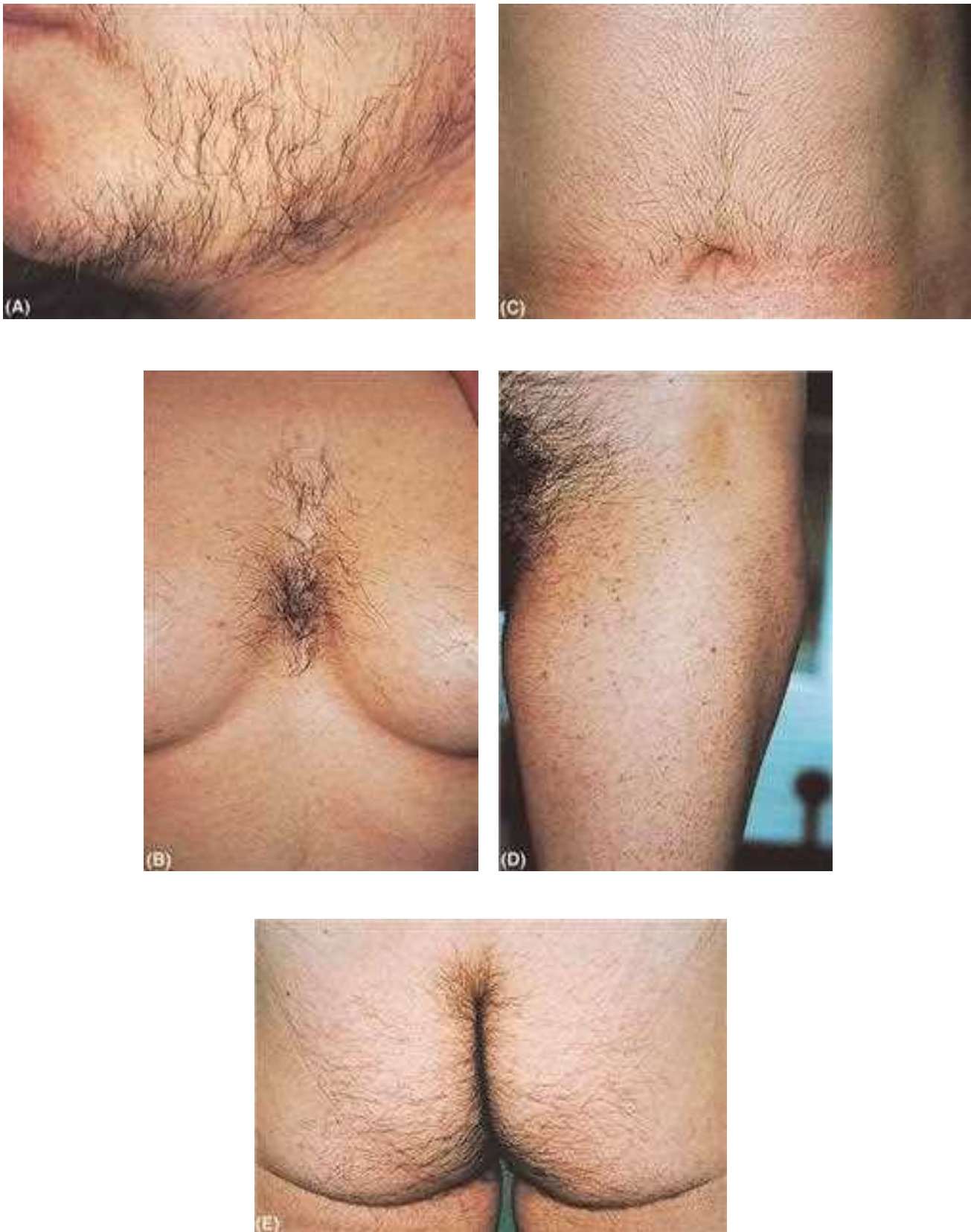
Hirsutism is characterized by androgen-dependent, excessive growth of terminal hairs in women in a pattern more characteristic of adult men. Such androgen-dependent areas include the chin, upper lip, chest, breasts, abdomen, back, and anterior thighs (Fig. 36.1). Objective assessment of hirsutism can be

obtained by evaluation and grading of hair growth and distribution according to the Ferriman-Gallwey (F-G) scale (Fig. 36.2). The F-G score quantifies the extent of hair growth in nine key anatomic sites, which is graded using a scale from 0 (no terminal hair) to 4 (complete and heavy cover), for a maximum score of 36 (2). Hirsutism is defined by a score of 8 or more. Approximately 5% to 10% of women of reproductive age in the general population are hirsute, assessed as having a F-G score of 8 or more (3). A 1993 market survey of 25,000 women in the United States concluded that 41% of women remove unwanted hair and 22% remove facial hair on a weekly basis (4). But far from being only a cosmetic problem, hirsutism may be a marker for an underlying hormonal disorder, and identification of the underlying etiology helps to detect patients at risk for infertility, diabetes mellitus, cardiovascular disease, and endometrial carcinoma (4).

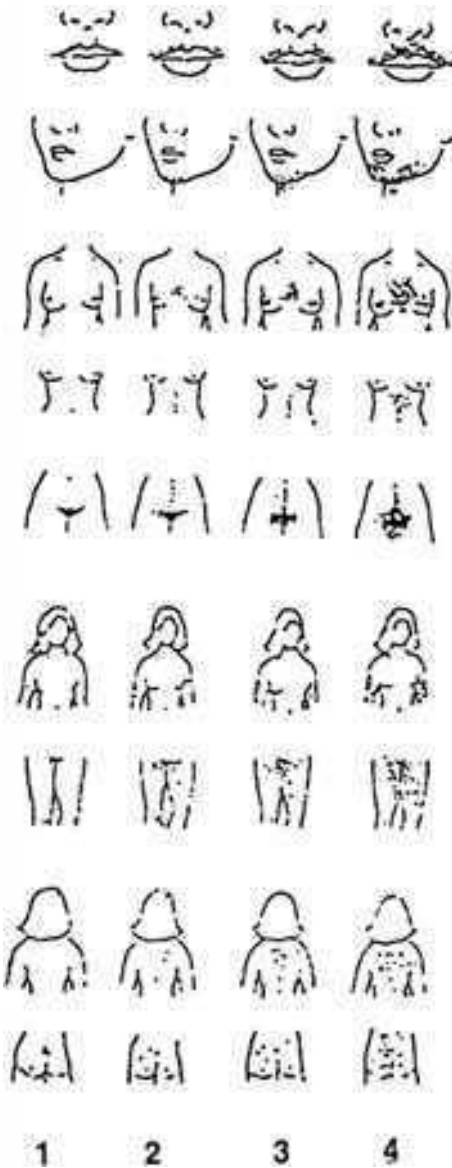
Hirsutism results from either an exogenous or endogenous increase in circulating androgens or from increased sensitivity (metabolism) of the hair follicle to normal serum androgen levels. Exogenous sources include androgenic medications, such as oral contraceptives with androgenic progestins (norgestrel, levonorgestrel, norethindrone), anabolic steroids (danazol), high-dose glucocorticoids, androgen therapy (testosterone), and valproic acid (raises plasma testosterone). Endogenous androgens in women arise from the ovary or adrenal glands, and peripherally from the skin and fat. There is thought to be considerable heterogeneity of responses among androgen-dependent follicles in different individuals (5). Therefore, the clinical severity of hirsutism does not always correlate well with expected levels of circulating androgens.

Seventy to eighty percent of patients with androgen excess demonstrate hirsutism (6), with the most common cause being *polycystic ovary syndrome (PCOS)*. Up to 6% of women overall are affected by PCOS in whom hirsutism is the most common manifestation. It represents a syndrome of hyperandrogenic anovulation that is due to an intrinsic ovarian dysfunction, which is often aggravated by insulin-resistant hyperinsulinemia with its risks of diabetes mellitus, metabolic syndrome, and their complications (7). Other, less frequent causes of androgen excess are *late onset congenital adrenal hyperplasia*, *Cushing's syndrome*, and the *HAIR-AN syndrome* (acronym for hyperandrogenism, insulin resistance, and acanthosis nigricans) (Fig. 36.3). *Pituitary*, *ovarian*, and *adrenal tumors* are important but rare causes of hirsutism.

Hirsutism is deemed *idiopathic* where it develops in the absence of detectable androgen excess and in conjunction with regular ovulation. It accounts for less than 20% of hirsute women (3). The definition of idiopathic hirsutism has been an evolving concept, since normal androgen levels have been



**Figure 36.1** Hirsutism: excessive growth of terminal hairs in androgen-dependent areas: (A) chin, (B) chest, (C) abdomen, (D) thighs, and (E) lower back. *Source:* From Ref. 1.



**Figure 36.2** Ferriman-Gallwey score: hair growth is rated from 0 (no growth of terminal hair) to 4 (complete and heavy cover) in nine locations, giving a maximum score of 36. *Source:* Adapted from Refs. 1 and 2.

defined by conventional laboratory tests, while more sophisticated testing methods may uncover occult ovarian or adrenal functional hyperandrogenism in a large number of these patients (8).

**Hypertrichosis**

Hypertrichosis is the term used for the growth of hair on any part of the body in excess of the amount usually present in persons of the same age, race, and sex, excluding androgen-induced hair growth (9). It may involve lanugo (hypertrichosis lanuginosa), vellus, or terminal hairs, and is classified on the basis of the age of onset (congenital or acquired), the extent of



**Figure 36.3** HAIR-AN: woman with hirsutism and acanthosis nigricans of the lateral neck area. *Source:* From Ref. 1.



**Figure 36.4** Lumbosacral hypertrichosis should draw the attention to the possibility of underlying spinal dysraphism with potential neurologic sequels. *Source:* From Ref. 1.

distribution (generalized or circumscribed), and the site involved (10). In both its generalized and circumscribed forms, hypertrichosis may be an isolated finding, or be associated with other abnormalities. For instance, lumbosacral hypertrichosis (Fig. 36.4) frequently indicates occult spinal defects, and it is essential that this possibility is investigated early, if neurologic sequels are to be prevented.



**Figure 36.5** Universal congenital hypertrichosis or Ambras syndrome: congenital generalized vellus-type hair hypertrichosis.

*Universal congenital hypertrichosis* (Fig. 36.5) is a rare and particularly dramatic familial disorder. In former times such individuals were sought after by sovereigns to adorn their courts, or exhibited by showmen to satisfy the curiosity of the public. Since the first well-documented observation concerns a man named Petrus Gonsalvus, born in 1556, and his family, whose portraits are shown in the castle of Ambras near Innsbruck, Austria, the term *Ambras syndrome* has been coined for this disorder (11). The whole body is covered with a remarkable amount of long, vellus-type hair, sparing only areas in which ordinarily no hair grows, including the palms, soles, and mucosae. The forehead, eyelids, nose, cheeks and preauricular region are uniformly covered with hair, reaching a length of several decimeters. The hair is light colored and silky; only the scalp hair, eyebrows, eyelashes and the axillary hair are darker. No decrease of hairiness during later life occurred in any of the well-documented cases.

*Prepubertal hypertrichosis* (Fig. 36.6) is a generalized terminal hair hypertrichosis affecting healthy children (12). There is hair growth on the temples spreading across the forehead, bushy eyebrows, and marked growth of hair on the upper back and proximal limbs. The condition is usually noted at birth, increases in severity during early childhood, and is not rare. It probably often has been confused with “racial hirsutism,” though it is not limited to a specific race nor androgen mediated.

Congenital generalized hypertrichosis has been associated with a number of abnormalities, such as gingival fibromatosis, osteochondrodysplasia, or congenital amaurosis, or may be a symptom of a more complex syndromatic disorder, such as the Cornelia de Lange syndrome, the mucopolysaccharidoses, and porphyries (9). In these cases, excessive body and facial hairs is either present at birth or develops during early infancy or puberty, and frequently involves terminal hairs.

A variety of underlying pathologic states may give rise to acquired generalized hypertrichosis. These include: head injuries and other cerebral disturbances, malnutrition and anorexia nervosa, juvenile hypothyroidism, and juvenile dermatomyositis (9). Besides acquired trichomegaly (overgrowth of eyelashes), a more generalized form of hypertrichosis has also been observed in patients with AIDS (13).



**Figure 36.6** Prepubertal hypertrichosis: congenital generalized terminal hair hypertrichosis. *Source:* From Ref. 1.

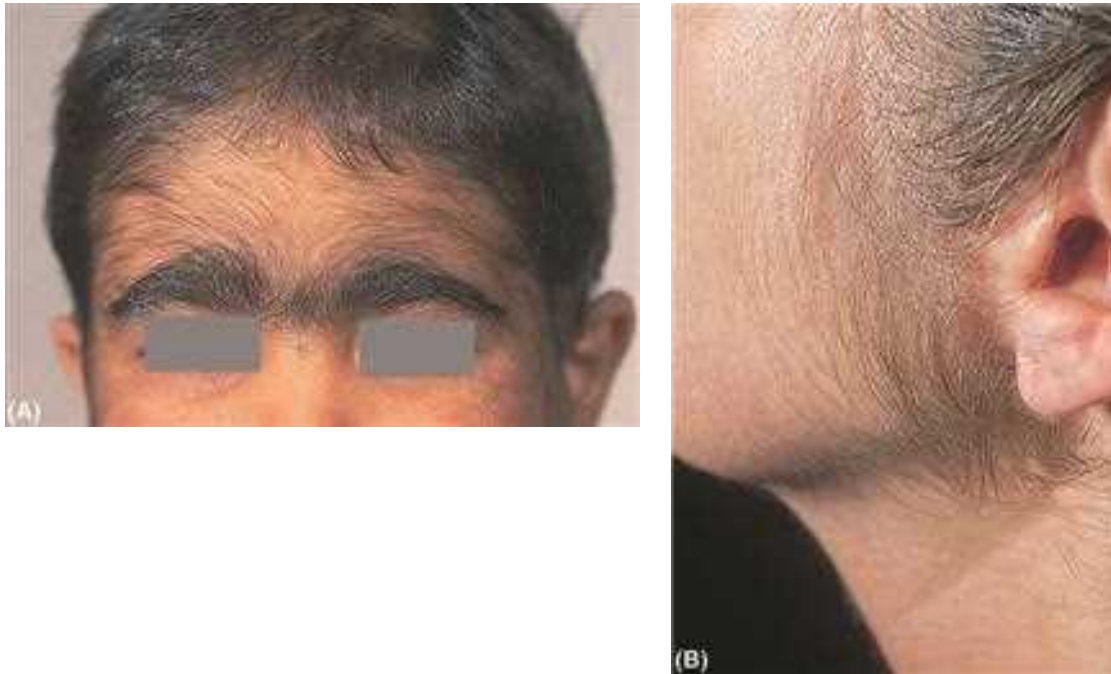
*Acquired hypertrichosis lanuginosa* describes the sudden onset and rapid growth of long, fine, lanugo-type, white-yellow downy hairs over a large area of the body in association with an underlying malignancy. While this presentation represents an exceedingly rare event, it is now becoming clear that the less conspicuous growth of lanugo (so-called “malignant down”), particularly on the face of patients with malignant disease, is not so uncommon (14). The lanugo may develop a few weeks or up to two years before an underlying malignancy is diagnosed.

Yet another form of paraneoplastic hypertrichosis may be found in the *POEMS syndrome* (Fig. 36.7), an acronym for the



**Figure 36.7** Acquired generalized terminal hair hypertrichosis in *POEMS syndrome*. *Source:* From Ref. 1.





**Figure 36.8** Drug-induced hypertrichosis: (A) cyclosporin A induced in a child and (B) topical minoxidil induced in a woman. *Source:* From Ref. 1.

major constellation of signs including peripheral neuropathy, organomegaly, endocrine dysfunction, monoclonal gammopathy, and skin changes (15). The hypertrichosis is of the terminal hair type and most common on the extensor surfaces, malar areas, and forehead.

Finally, several drugs are well known to cause significant generalized hypertrichosis, the most frequent currently being corticosteroids, phenytoin sodium, cyclosporin A, and minoxidil (Fig. 36.8) (9). Discontinuation of the offending drug leads to resolution of drug-induced hypertrichosis within several months to one year, depending on the hair cycling characteristics of the affected site (face, three months; arms, one year).

### MANAGEMENT OF EXCESSIVE HAIR

Accurate classification of excess hair must precede treatment and includes: characterization of the type of hair involved (lanugo, vellus, terminal), characterization of the pattern of hair growth (generalized or circumscribed hypertrichosis, hirsutism), age at initial manifestation (congenital, acquired), patient history with regard to systemic disorders or drug intake, physical examination for associated abnormalities, and family history, including ethnic and racial background (9). It must always be kept in mind that hair overgrowth, either hirsutism or hypertrichosis, may be a manifestation of a more general medical problem that needs to be investigated. Testing of androgen levels is recommended in women with moderate to severe hirsutism (F-G score of 15 or more), and in women with any degree of hirsutism when it is sudden in onset, rapidly progressive, or when it is associated with any of the

following: menstrual irregularity, central obesity, acanthosis nigricans, or clitoromegaly (16).

The current available treatment methods for removal of unwanted hair include: cosmetic procedures, medical treatment, and hair removal using lasers and light sources. These may be combined (9,17).

### Cosmetic Procedures for Removal of Excessive Hair

Unwanted hair may be masked by bleaching or removed by a variety of physical methods such as trimming of the hair, shaving, plucking or tweezing, and waxing, or chemical procedures (depilatories), and electrosurgical epilation (18).

*Bleaching* is a quick, easy, and painless process that can make unwanted hair less apparent through the partial or total removal of natural hair pigment, lightening the hair to a yellowish hue. A home bleach is made by mixing 40 mL hydrogen peroxide with 7 mL 20% ammonia. This is left in contact with the hair until the color is removed, usually 5 to 10 minutes. Bleaching can last up to four weeks. This method is best for uses for treatment of localized excess pigmented hair on the face or arms of fair-skinned patients, because yellow-bleached hair may emphasize the hair when viewed against the skin of more darkly pigmented patients. Occasionally, bleaching results in skin irritation. The addition of a persulfate to boost the peroxide bleach in commercial products may occasionally result in anaphylaxis in the sensitized individual (19).

*Trimming of the hair* is a recommended option for young children with either localized or generalized hypertrichosis,

making the hair of involved areas less noticeable, while not resulting in acceleration of hair regrowth.

### Shaving

While unacceptable for removing facial hair to many women, the majority accepts to shave excess body hair. It is perceived as being fast, effective, easy, and cheap. Contrary to popular belief, shaving does not affect the width or rate of regrowth of individual hairs (20), though the perception of the stubble as it grows out, without the finer tapered end of unshaven hair may give this impression. As a consequence, daily shaving must be undertaken or the cosmetic result is worsened. The disadvantages of shaving are the need to shave daily, and skin irritation. Although dry or electrical shaves are not as close as wet shaves, a dry electric razor has been effectively used to treat generalized hypertrichosis during the neonatal period (21).

*Plucking* is an effective temporary hair removal method, but it is slow, tedious, and painful. It is only appropriate for individual, small groups or scattered coarse hair and is performed with tweezers (tweezing). Adverse reactions of plucking include hyperpigmentation, folliculitis, scarring, ingrown hairs, and distorted follicles. A variation of plucking for treatment of more diffuse hypertrichosis acts as mechanized tweezers using a rotating, fine, coiled spring that grasps the hair shaft and pulls it out. The device is handheld and moved over the skin like a shaver. A drawback of this method is that it is painful.

*Waxing* is performed with cold, warm, or hot wax. The wax is applied to hair-bearing areas, and stripped off, epilating the embedded hairs. Waxing methods are an efficient way of plucking vellus hairs in all areas of the body, and inexpensive when performed at home. The major disadvantages are discomfort, poor removal of short hair, and skin irritation or folliculitis. The method is too painful for use on children with hypertrichosis. As with hair plucking, the regrowth period is longer than that for shaving, and it requires to be repeated only every two to six weeks.

The Oriental techniques of *sugaring* (22) and *threading* (23) remove hair in much the same manner. Instead of using wax, the hairs are plucked out by a caramelized sugar mass or the scissoring action of a twisted thread, respectively.

*Chemical depilatories* function by damaging the hair to the point where it breaks at the skin surface. Substituted thiols form the basis of practically all contemporary preparations. Depilatories contain detergents to remove the protective sebum from the hair, adhesives that aid the depilatory in sticking to the hair shaft, swelling agents for better penetration of the bond-breaking agent, pH adjusters, and disulfide bond-breaking agents (thioglycolic acid, calcium thioglycolate). Thioglycolates are used in a concentration of 2% to 4%, and act within 5 to 15 minutes. Since thioglycolates attack keratin, and the hair shaft and skin are similar in their keratin composition, most chemical depilatories hold a high irritancy potential and may have adverse effects on the skin if the manufacturers' recommendations are not carefully followed. Additional adverse effects from the use of thioglycolates include allergic contact dermatitis and with inadvertent eye contact, corneal alkali burns (24,25). Their application is messy, and they have an unpleasant odor and are relatively expensive, especially if treating larger areas. Chemical depilatories are most appropriate for weekly hair removal from small areas. In children with extensive hypertrichosis treatment with chemical depilatories should be limited to localized sites because of a theoretical risk of additional toxicity from systemic thioglycolate absorption (26).

### Electrosurgical Epilation

In contrast to the other cosmetic procedures for hair removal electrosurgical epilation represents a permanent mode of hair removal. Treatment involves the insertion of a disposable, fine wire needle into the hair follicle. Through this instrument a regulated and controlled electric current is transmitted from a highly sophisticated apparatus known as an epilator. The procedure is performed by a highly trained professional. Three techniques are available: galvanic electrolysis, thermolysis, and the blend method (27,28). *Galvanic electrolysis* uses galvanic current to destroy the hair growing cells of the hair follicle. This involves a direct current process that produces an electrochemical formation of sodium hydroxide, which congeals the hair follicle. *Thermolysis* uses high-frequency electrocoagulation that cauterizes the hair follicle. Galvanic electrolysis is slower, but destroys more follicles in one treatment, while thermolysis is quicker, but more regrowth is seen with this method. The *blend method* combines both galvanic and high-frequency current from a single machine, and is considered by most users to be the most effective method of electrosurgical epilation. Disadvantages of electrosurgical epilation are the length and the number of treatments required for permanent removal of hair in a particular body site, and discomfort during treatment, which is why the method is poorly tolerated in children. Generally, operators can only deal with 25 to 100 hairs per session, and individual treatments last from 15 minutes to one hour. Problems that may occur are perifollicular inflammation, postinflammatory hyper- or hypopigmentation, and less frequently, punctate scarring. The method is most suitable for treatment of localized, coarse hair.

### Medical Treatment

Since abnormal hair growth in hirsutism is either stimulated by excess androgens, or is related to hair follicle sensitivity to androgens, hormonal treatment of hirsutism is based on suppressing androgen production or counteracting the biologic activity of androgens.

Today, for the majority of women with hirsutism, a monotherapy with *oral contraceptive pills (OCPs) that have anti-androgenic activity* is recommended as first-line treatment.

*Antiandrogens* may be the first-line therapy for postmenopausal women, or may be indicated in conjunction with OCPs in premenopausal women if clinical improvement is insufficient after six or more months of monotherapy. The choice between the different antiandrogens depends on patient preferences regarding efficacy, side effects, and costs (29). Antiandrogens including spironolactone, cyproterone acetate, and flutamide, or the 5 $\alpha$ -reductase inhibitors such as finasteride, should not be used in women of childbearing age unless they are strictly combined with a safe contraception method due to their potential feminizing effect on the male fetus (16).

In women with hirsutism, hyperandrogenism, and insulin resistance, *insulin sensitizers* such as metformin and rosiglitazone are effective for the hirsutism as well as the hyperinsulinemia, hyperandrogenism, and infertility, but there is no convincing evidence that they are effective for hirsutism alone (30).

*Topical eflornithine cream* is a medical treatment for slowing excessive hair growth and not removing excess hair (31). The compound is a specific and irreversible inhibitor of the enzyme ornithine decarboxylase present in hair follicles that is important in hair growth. In clinical studies in women with facial hirsutism, twice daily application of eflornithine hydrochloride

monohydrate 15% cream (Vaniqa<sup>®</sup>, Bristol-Myers Squibb, New York, New York, U.S.) was superior to placebo in reducing hair growth, as demonstrated by objective and subjective methods, after two- to eight-week treatment. After 24-week treatment, 58% of eflornithine and 34% of placebo recipients had at least some improvement, and 32% versus 8% of patients were judged to be successfully treated (at least marked improvement) (32). Hair growth returned to pretreatment rates within eight weeks of stopping treatment. Local irritation, characterized by burning, stinging, and/or tingling, occurred more frequently in eflornithine-treated patients. Use of eflornithine cream in combination with other therapies, including laser epilation, can be effective and results in a more rapid, visible hair reduction compared with laser monotherapy (33).

The safety and efficacy of topical eflornithine treatment for widespread hypertrichosis and children has not been established.

### Hair Removal Using Lasers and Light Sources

The need for a rapid, noninvasive method for hair removal has led to the development of various laser and light sources for this purpose. An array of devices is now available. All are based on the principle of selective photothermolysis: Melanin pigment in the hair follicle provides the chromophore for

selective targeting of hair follicles, while the surrounding dermis is spared. Therefore, at deeply penetrating wavelengths in the 600- to 1100-nm range, melanin absorption may be used for selective photothermolysis of hair follicles (34).

Several hair removal systems have been shown to be effective in this setting: *long-pulsed ruby lasers* (wavelength 694 nm; pulse duration 1–3 msec), *long-pulsed alexandrite lasers* (755 nm; 2–20 msec), *diode lasers* (800 nm; 5–400 msec), *long-pulsed neodymium:yttrium-aluminum-garnet (Nd:YAG) lasers* (1064 nm; 5–250 msec), and *intense pulsed-light (IPL) sources* (590–1400 nm; 2.5–5 msec) (35–38). The physical parameters (wavelength, pulse duration, fluence, spot size, repetition rate) and cooling systems used with each system vary considerably. Regardless of the type of laser or light source used, all systems have been shown to temporarily reduce hair growth. Long-term, controlled hair counts have shown an average of 20% hair loss with each treatment, indicating the need for multiple treatments to achieve satisfactory results. Research indicates that in 80% of patients significant hair reduction can be achieved (Fig. 36.9), while 20% will fail (35). Effectiveness for long-lasting hair reduction is strongly correlated with hair color. Blond-, red-, or white-haired patients are unlikely to experience a permanent reduction. In contrast, the patient with dark hair and fair skin may experience long-term hair removal after a single treatment (36). Often, regrowing hairs are thinner and



**Figure 36.9** Terminal hair growth of the back in a male patient (A) before and (B) six months after fifth in-office intense pulsed-light treatment (delivered at two-month intervals).



**Figure 36.10** Silk'n®: handheld intense pulse light device for home-based hair removal.

lighter in color, contributing to the improvement in the overall appearance. Although there is no obvious advantage of one laser system over another in terms of treatment outcome, laser parameters may be important for choosing the ideal laser for a patient (37). A major drawback to using shorter wavelengths, for example, 694 nm ruby, is that a more deeply pigmented epidermis impedes laser radiation penetration of the dermis. The amount of light that reaches the hair bulb is therefore reduced with decreased efficacy. At the same time, unwanted epidermal injury may occur. Patients with darker skin tones should therefore receive laser treatment with either lower fluences of alexandrite and diode laser or with a long-pulsed Nd:YAG laser. Adverse effects include commonly erythema and perifollicular edema, while crusting and vesiculation of treatment site, hypopigmentation and hyperpigmentation are less frequent, and depending on skin color and other factors. Most complications are usually temporary, and their incidence can be reduced by lightening of the skin and sun avoidance prior to laser treatment, effective cooling of the skin during treatment, and sun avoidance and protection following treatment (37). Shaving the hair-bearing site is performed preoperatively to prevent conduction of thermal energy to the adjacent epidermis from overlying hairs. One peculiar unwanted effect of laser-assisted hair removal is the stimulation of new hair growth within previously treated areas or in close proximity. This “paradoxical effect” has been seen following treatment with each of the laser and light hair removal systems, and its development has been attributed to activation of previously dormant hair follicles by either the application of subthreshold fluences or the conduction of heat to surrounding areas (39,40).

As with traditional electrosurgical epilation, laser epilation is uncomfortable, which limits its usefulness in children with widespread hypertrichosis (4).

Since removing hair with in-office laser- or light-based treatments is expensive and requires multiple treatment sessions, recently, a novel, low-energy, pulsed-light device for home-use hair removal (Silk'n®, Home Skinovations Ltd., Yokneam, Israel) (Fig. 36.10) has been developed to overcome these disadvantages. The device is composed of two flashlamps in a handheld applicator (optical filter 475–1200 nm; fluences up to 5 J/cm<sup>2</sup>). A study was performed with 20 women with Fitzpatrick skin phototypes I to IV and dark terminal hair in nonfacial sites (axilla, forearms, inguinal region, legs) who self-administered three treatments at two-week intervals using the device. Matched untreated skin sites were compared. Hair counts and clinical photographs were obtained pretreatment and at one, three, and six months after the third treatment, side effects and patient satisfaction scores were recorded. All patients showed a positive clinical response to treatment, with reduction of unwanted hair, while no hair reduction was noted in untreated matched areas. Hair counts were reduced 37.8% to 53.6% six months after the three treatments. Lower legs exhibited greater hair reduction than arms, inguinal, and axillary areas. Mild erythema was experienced in 25% of patients, but no other unwanted effects were encountered. Patient satisfaction scores were high, with all patients stating that they would purchase the device for future home use (41).

## CONCLUSIONS

Removal of unwanted hair is the most popular skin treatment worldwide. Excessive hair may cause cosmetic embarrassment, resulting in significant emotional burden. Sometimes the complaint of excess hair may pose a vexing problem for non-specialized physicians, who tend to trivialize the complaint, though an individual's perception of abnormality is important in determining whether or not medical care is sought. Moreover, it must always be kept in mind that hair overgrowth, either hirsutism or hypertrichosis, may be a manifestation of a more general medical problem that needs investigation. The dermatologist seeing a patient with hirsutism or hypertrichosis must be prepared to look for the physical clues and perform the workup that help both define the extent of excess hair and suggest the presence of associated disorders. No single method of hair removal is appropriate for all patients or body locations. The method adopted will depend on the cause, the character, area and amount of excessive hair growth, as well as on the age of the patient, and personal preference. The best treatment of hirsutism is often a combination of medical therapy and the physical removal of unwanted hair. Over the recent past, hair removal using various efficacious lasers and light sources have been advocated for use in an office setting, although most people continue to remove unwanted hair with a variety of temporary physical methods in a home setting, presumably due to cost and convenience factors.

## REFERENCES

1. Trüeb RM. Haare Praxis der Trichologie. Steinkopff Darmstadt, 2003.
2. Ferriman D, Gallwey JD. Clinical assessment of body hair growth in women. *J Clin Endocrinol Metab* 1961; 21:1440–1447.
3. Azziz R, Carmina E, Sawaya ME. Idiopathic hirsutism. *Endocr Rev* 2000; 21:347–362.

4. Somani N, Harrison S, Bergfeld WF. The clinical evaluation of hirsutism. *Dermatol Ther* 2008; 21:376-391.
5. Rosenfield RL. Hirsutism and the variable response of the pilosebaceous unit to androgen. *J Investig Dermatol Symp Proc* 2005; 10:205-208.
6. Azziz R. The evaluation and management of hirsutism. *Obstet Gynecol* 2003; 101:995-1007.
7. Rosenfield RL. What every physician should know about polycystic ovary syndrome. *Dermatol Ther* 2008; 21:354-361.
8. Rossi R, Tauchmanová L, Luciano A, et al. Functional hyperandrogenism detected by corticotropin and GnRH-analogue stimulation tests in women affected by apparently idiopathic hirsutism. *J Endocrinol Invest* 2001; 24:491-498.
9. Trüeb RM. Causes and management of hypertrichosis. *Am J Clin Dermatol* 2002; 3:617-627.
10. Vashi RA, Mancini AJ, Paller AS. Primary generalized and localized hypertrichosis in children. *Arch Dermatol* 2001; 137:877-884.
11. Baumeister FAM, Egger J, Schildhauer MT, et al. Ambras syndrome: delineation of a unique hypertrichosis universalis congenital and association with a balanced pericentric inversion (8)(p11.2;q22). *Clin Genet* 1993; 44:121-128.
12. Barth JH, Wilkinson JD, Dawber RPR. Prepubertal hypertrichosis: normal or abnormal? *Arch Dis Child* 1988; 63:666-668.
13. Prose NS, Abson KG, Scher RK. Disorders of the nails and hair associated with human immunodeficiency virus infection. *Int J Dermatol* 1992; 31:453-457.
14. Fretzin DF. Malignant down. *Arch Dermatol* 1967; 95:294-297.
15. Pernicario C. POEMS syndrome. *Semin Dermatol* 1995; 14:162-165.
16. Martin KA, Chang RJ, Ehrmann DA, et al. Evaluation and treatment of hirsutism in premenopausal women: an endocrine society clinical practice guideline. *J Clin Endocrinol Metab* 2008; 93:1105-1120.
17. Liew SH. Unwanted body hair and its removal: a review. *Dermatol Surg* 1999; 25:431-439.
18. Draelos ZK. *Cosmetics in Dermatology*. New York: Churchill Livingstone, 1990:99.
19. Wagner RF. Physical methods for the management of hirsutism. *Cutis* 1990; 45:19-26.
20. Lynfield YL, MacWilliams P. Shaving and hair growth. *J Invest Dermatol* 1970; 55:170-172.
21. Partridge JW. Congenital hypertrichosis lanuginosa: neonatal shaving. *Arch Dis Child* 1987; 62:623-625.
22. Tannir D, Leshin B. Sugaring: an ancient method of hair removal. *Dermatol Surg* 2001; 27:309-311.
23. Scott MJ, Scott MJ III, Scott HM. Epilation. *Cutis* 1990; 46:216-217.
24. Yamasaki R, Dekio S, Jidio J. Allergic contact dermatitis to ammonium thioglycolate. *Contact Dermatitis* 1984; 11:255.
25. Smith RS, Shear G. Corneal alkali burns arising from accidental instillation of a hair straightener. *Am J Ophthalmol* 1975; 79:602-605.
26. Freeman MV, Draize JH, Smith PK. Some aspects of the absorption, distribution and excretion of sodium thioglycolate. *J Pharm Exp Ther* 1956; 118:296-303.
27. Hobbs ER, Ratz JL, James B. Electrosurgical epilation. *Dermatol Clin* 1985; 5:437-444.
28. Richards RN, Meharg GE. Electrolysis: observation from 13 years and 140000 hours of experience. *J Am Acad Dermatol* 1995; 33:662-666.
29. Swiglo BA, Cosma M, Flynn DN, et al. Antiandrogens for the treatment of hirsutism: a systematic review and metaanalyses of randomized controlled trials. *J Clin Endocrinol Metab* 2008; 93:1153-1160.
30. Cosma M, Swiglo BA, Flynn DN, et al. Insulin sensitizers for the treatment of hirsutism: a systematic review and metaanalyses of randomized controlled trials. *J Clin Endocrinol Metab* 2008; 93:1135-1142.
31. Barman Balfour JA, McCellan K. Topical eflornithine. *Am J Clin Dermatol* 2001; 2:197-201.
32. Wolf JE Jr, Shander D, Huber F, et al. Randomized, double-blind clinical evaluation of the efficacy and safety of topical eflornithine HCl 13.9% cream in the treatment of women with facial hair. *Int J Dermatol* 2007; 46:94-98.
33. Smith SR, Piacquadio DJ, Beger B, et al. Eflornithine cream combined with laser therapy in the management of unwanted facial hair growth in women: a randomized trial. *Dermatol Surg* 2006; 32:1237-1243.
34. Ross EV, Ladin Z, Kreindel M, et al. Theoretical considerations in laser hair removal. *Dermatol Clin* 1999; 17:333-355.
35. Dierickx C, Alora MB, Dover JS. A clinical overview of hair removal using lasers and light sources. *Dermatol Clin* 1999; 17:357-366.
36. Olsen EA. Methods of hair removal. *J Am Acad Dermatol* 1999; 40:143-155.
37. Liew SH. Laser hair removal. Guidelines for management. *Am J Clin Dermatol* 2002; 3:107-115.
38. Wanitphakdeedecha R, Alster TS. Physical means of treating unwanted hair. *Dermatol Ther* 2008; 21:392-401.
39. Alajlan A, Shapiro J, Rivers JK, et al. Paradoxical hypertrichosis after laser epilation. *J Am Acad Dermatol* 2005; 53:85-88.
40. Lolis MS, Marmur ES. Paradoxical effects of hair removal systems: a review. *J Cosmet Dermatol* 2006; 5:274-276.
41. Alster TS, Tanzi EL. Effect of a novel low-energy pulsed-light device for home-use hair removal. *Dermatol Surg* 2009; 35:483-489.

## Pigmentation: dyschromia

Thierry Passeron and Jean-Paul Ortonne

### INTRODUCTION

Variations of skin pigmentation are mostly due to quantitative or qualitative defects of melanin pigments (eumelanin and pheomelanin). However, dyschromia can also result from an abnormal increase or decrease of other endogenous pigments (hemoglobin, bilirubin, etc.) or from the deposit of exogenous pigments (heavy metals, cosmetic tattoos, etc.). This leads to a heterogeneous group with numerous causes. Although most of the patients will consult for the cosmetic disturbance due to the dyschromia, it is essential to determine the origin of the pigmentary trouble to propose the more adapted treatment and if necessary to ask for complementary investigations.

### PATHOPHYSIOLOGY OF DYSCHROMIA

The color of the skin results from the presence of pigments in the epidermis and dermis. The melanins (eumelanin, dark brown, mostly produced by dark phototypes, and pheomelanin, red-fair brown, mostly observed in fair phototypes) are the most important pigments in human skin. However, other endogenous pigments such as hemoglobin and bilirubin also play a role in the color of the teguments. Dyschromia can result from darkening, lightening, and discoloration of skin (1). Quantitative or qualitative defects in the production or in the deposition of melanin explain most of the pigmentary disorders, but abnormal variations of other endogenous pigments and deposit of exogenous pigments also lead to dyschromic lesions.

An increased amount of melanin in the skin is called hypermelanosis or melanoderma. A brown hypermelanosis is caused by excessive amounts of melanin within the epidermis whereas ceruloderma (or blue hypermelanosis) results from large amounts of melanin in the dermis. Mixed hypermelanosis characterized by an excess of melanins in both epidermis and dermis may also occur. Epidermal hypermelanosis may result from increased melanin production by a quantitatively normal melanocyte density in the epidermis (melanotic hypermelanosis) or by an increased number of epidermal melanocytes (melanocytic hypermelanosis). Dermal hypermelanosis can be due to the production of melanin by ectopic dermal melanocytes (dermal melanocytosis) or to an abnormal transfer of melanin from epidermal cells to the dermis (pigmentary incontinence). In this situation, melanin granules accumulate within melanophages or may be free in the extracellular matrix of the dermis.

Skin lightening or whitening (leukoderma, hypopigmentation) is most commonly the result of decreased melanin content in the skin (hypomelanosis). Hypomelanosis may be the result of at least two different pathogenic mechanisms: partial or total absence of epidermal melanocytes (melanocytopenic hypomelanosis) or even melanin synthesis, melanosome biogenesis, transport, and transfer, and melanosome transfer despite a nor-

mal number of epidermal melanocytes (melanopenic hypomelanosis). Increase of epidermal turnover can also induce hypomelanosis. Hypo- and hyperpigmentation disorders can be inherited or acquired (2,3).

Dyschromia that result from variation of the hemoglobin content within the skin (diffuse such as in anemia or in polycythemia, or localized such as in Bier spots) can be easily distinguished from other pigmentary disorders as the change in color disappears with pressure (Fig. 37.1). Xanthoderma describes a yellow to orange macular discoloration of the skin. Jaundice and carotenoderma are the two main causes of xanthoderma. Although patients may consult for the cosmetic disturbance, drug and excessive dietary intake of carotenoids and search for underlying disease have to be performed (4). The treatment is etiological. Heavy metals (e.g., iron, silver, copper, etc.) and traumatic, medical, or esthetical tattoos are other sources of skin discoloration.

### DEPIGMENTING AGENTS Phenolic Compounds

#### *Hydroquinone*

Hydroquinone (HQ) is the most popular depigmenting agent (5). Several studies have established the therapeutic effect of HQ in the treatment of hypermelanosis (6). HQ is still the "gold standard" of depigmenting agents. The effectiveness of HQ is related directly to the concentration of the preparations, the vehicle used, and the chemical composition of the final product. 2% HQ was reported to improve hypermelanosis in 14% to 70% of the patients. However, HQ is most commonly used at a 4% concentration by dermatologists. At this concentration, HQ is very effective, but it can have a significant irritant effect. Concentrations as high as 6% to 10% are prescribed extemporaneously for resistant cases, but may have a strong irritant effect. Because of the hazard of long-term treatments, the use of HQ in cosmetics has been banned by the European Committee (24th Dir. 2000/6/EC). Formulations are available only by prescription of physicians and dermatologists. A number of different vehicles can be used for HQ, but the most suitable for the formulation is a hydroalcoholic solution (equal parts of propylene glycol and absolute ethanol). A nitro-oxidant such as ascorbic acid (ASA) or sodium bisulphate is regularly used to preserve the stability of the formulation.

The acute side effects of HQ include irritant and allergic contact dermatitis, nail discoloration, and post-inflammatory hypermelanosis (7). These adverse events are temporary and resolve after HQ discontinuation. Higher concentrations ( $\geq 5\%$ ) may induce persistent hypo- or amelanosis (leukoderma en confetti). Exogenous ochronosis is a very rare complication occurring in dark-skinned or black individuals after chronic use. This irreversible disorder presents in the form of



**Figure 37.1** Bier spots on the arm of a young adult.

reticulated, ripple like, sooty pigmentation affecting common sites of HQ applications (cheeks, forehead, periorbital areas). The lesions are typically localized on photoexposed areas. Histological examination of these lesions shows banana-shaped yellow-brown pigment granules in and around collagen bundles in conjunction with giant cells and melanophage-containing granulomas in the upper dermis.

The pathogenesis of HQ-induced ochronosis is unknown, and no effective treatment is available. The mode of action of HQ is not fully understood. HQ seems to exert its effect mainly in melanocyte with active tyrosinase activity. Guidelines and radical oxygen species arising from the oxidation of HQ induce an oxidative damage of membrane lipids and proteins including tyrosinase, and depletion of glutathione contributes to the lightening action (8). Other depigmenting pathways attributed to HQ include inhibition of tyrosinase through the covalent binding to histidine or interactions with copper at the active site of tyrosinase, inhibition of DNA and RNA synthesis and alteration of melanosome formation and melanization extent.

## Hydroquinone Derivatives

### *Monobenzylether d'hydroquinone*

The clinical use of monobenzylether d'hydroquinone (MBEH) is restricted for generalized depigmentation in patients with extensive vitiligo. MBEH should never be used for the treatment of melasma or post-inflammatory hypermelanosis. Indeed MBEH causes permanent depigmentation of the skin even at sites distant from those of application. MBEH-induced vitiligo depigmentation has been described in dark-skinned individuals. MBEH is metabolized to reactive free radicals inside the cells resulting in melanocyte destruction.

### *Monomethyl of Hydroquinone*

Monomethyl of hydroquinone (MMEH) is also called 4-hydroxyanisole (para-hydroxy-methoxy-benzene). This compound is oxidized by tyrosinase and exhibits strong melanocytotoxicity. MMEH is used in France at 8% or 10% concentration for the treatment of various acquired

hypermelanoses including melasma and post-inflammatory hypermelanoses. Side effects include irritant and allergic contact dermatitis, post-inflammatory hypermelanosis, and leukoderma en confetti at treated sites. Hypomelanosis at sites distant from the application areas have been reported.

## Others

### *4-n-Butylresorcinol (Rucinol®)*

4-n-Butylresorcinol has an inhibitory effect on tyrosinase and tyrosinase-related protein (TRP-1). A lotion containing 0.3% 4-n-butylresorcinol has been demonstrated to improve melasma. This product also decreases post-inflammatory hyperpigmentation (PIH) following laser therapy (9).

### *4-Isopropylcatechol (4-IPC)*

This compound is considered as more potent and more consistent in its depigmenting effect than HQ. A clinical trial involving 68 patients treated with 1% and 3% 4-IPC has demonstrated that this product is a potent depigmenting agent and is of use for the topical therapy of hypermelanosis (10).

### *Phenolic thioether*

N-Acetyl-4-S-cystalminylphenol has been evaluated in a small number of patients with melasma (11). Marked improvement or complete clearing with minimal side effects was obtained in 75% of patients. These compounds are not widely used, and large clinical trials to evaluate their safety and efficacy are not available.

### *Azelaic Acid*

Azelaic acid (AA) is a naturally occurring nine-carbon dicarboxylic acid isolated from cultures of *Pityrosporum ovale*. AA is thought to play a key role in the pathogenesis of hypomelanotic tinea versicolor. AA has been used at concentrations of 15% to 20% for the treatment of melasma and post-inflammatory hypomelanoses. The best results demonstrated that AA is more effective than 2% HQ and equivalent in efficacy with 4% HQ for the treatment of melasma in dark-skinned women (12). Similar good results have never been obtained in European patients. AA is well tolerated. Adverse effects such as pruritus, transient erythema, scaling, and irritation are usually mild and disappear within a few weeks. Phototoxic and allergic reactions are rare.

AA may halt the progression of lentigo maligna and even induce its disappearance suggesting that AA exert an anti-proliferative and cytotoxic effect mainly on hyperactive and abnormal melanocytes.

### *Soy and Soy-Based Products*

Soy and soy-based products may affect skin pigmentation. Several studies have demonstrated that soy-derived serine protease-inhibiting PAR-2 mediated phagocytosis of melanosomes by keratinocytes. Thus, soy-based products containing these serine protease inhibitors represent safe and effective products to treat hyperpigmentation (13).

### *Kojic Acid*

Kojic acid (KA) a fungal metabolic product is used at 1% to 4% concentrations. In monotherapy, KA shows a modest effectiveness. Thus, it is mainly used in combinations. It is a potent tyrosinase inhibitor and functions by chelating copper at the active site of the enzyme. Long-term side effects of KA are not

known. A high frequency of contact sensitivity has been reported (14). The use of KA in cosmetics has been banned in Japan.

#### *Ascorbic Acid*

A stable ester of ASA (magnesium L-ascorbyl-2 phosphate) in a 10% cream base produced a significant lightening effect in patients with melasma after three months of twice daily application (15). ASA interferes with the different steps of melanogenesis by interacting with copper ions at the tyrosinase active site and reducing dopaquinone and by blocking 5,6-dihydroxyindole-2-carboxylic acid (DHICA) oxidation. A randomized double-blind placebo-controlled trial of vitamin C iontophoresis in melasma has demonstrated that this strategy may be an effective treatment for melasma (16). A double-blind left/right randomized comparative study in melasma patients showed that 93% of good and excellent subjective results are observed on the 4% HQ side compared with 62.5% on the 5% ASA side. However, colorimetric measures showed no statistical differences. Side effects were more common with HQ (68.7%) than with ASA (6.2%) (17).

#### *Tranexamic Acid*

Tranexamic acid is known as an oral medicine for treating melasma. The antiplasma activity of tramexamic acid is thought to play a role in its topical effectiveness for treating melasma (18,19).

#### *Arbutin*

Arbutin is a naturally occurring  $\beta$ -D-glucopyranoside derivative of HQ. It inhibits tyrosinase activity. In a clinical trial, an arbutin-containing formulation (3%) was shown to be effective for treating hyperpigmentary disorders (19,20).

#### *Ellagic Acid*

Ellagic acid inhibits tyrosinase activity by chelating copper atoms in its active site. In a clinical trial, a 0.5% ellagic-containing cream was shown to be effective for treating UVB-induced hyperpigmentation of the skin (19,21).

#### *Chamomilla Extract*

Chamomilla extracts have been shown to act as an antagonist for endothelin receptor-binding that mediates cell-to-cell signaling between keratinocytes and melanocytes and leads to the inhibition of melanin synthesis in melanocytes. In a clinical trial, a 0.5% chamomilla extract-containing cream was shown to be effective for treating UVB-induced hyperpigmentation of the skin (19,22,23).

#### *Adenoside Monophosphate Disodium Salt*

Adenosine monophosphate disodium salt accelerates elevated intracellular energy metabolism that leads to the excretion of melanin from the skin, preventing the accumulation of melanin in the skin. In a clinical trial, a 3% adenosine monophosphate disodium salt-containing salt formulation was shown to be effective for treating hyperpigmentary disorders (19).

#### *5,5'-dipropyl-biphenyl-2,2-diol (Magnolignan)*

Magnolignan inhibits the maturation because of the glycosylation of tyrosinase and thus induce decrease melanin synthesis. 0.5% magnolignan-containing formulation was shown to be effective for treating UVB hyperpigmentation of the skin (24) and is also effective in treating hyperpigmentation disorders such as melasma and while lentigo (19,25).

#### *4-(4-Hydroxyphenyl)-2-butanol*

4-(4-Hydroxyphenyl)-2-butanol (4-HPB), a phenol compound, inhibits melanin synthesis due to its competitive inhibition of tyrosinase activity (19).

#### *Tranexamic Acid Cetyl Ester Hydrochloride*

The effect of tranexamic acid cetyl ester hydrochloride to treat hyperpigmentary disorders is due to the inhibition of UVB-induced inflammation that leads to the quiescence of active melanocytes (19).

#### *4-Methoxy Potassium Salicylate*

4-Methoxy potassium salicylate (4-MSK) inhibits melanin synthesis through competitive melanin of tyrosinase activity (19).

#### *Retinoid Monotherapy*

*Tretinoin.* Tretinoin (all trans retinoic acid—ATRA) has been used in concentrations from 0.025% to 0.1% to treat a variety of pigmentary disorders such as pigmented spots of photoaged skin, melasma, and PIH in dark-skinned individuals (26–29). Erythema and peeling in the area of application are adverse events of ATRA 0.05% to 0.1%. PIH may also occur. Topical ATRA appears to exert its action by enhancing keratinocyte proliferation and increasing epidermal cell turnover. However, ATRA, acting on retinoid-activating transcription factors, interferes with melanogenesis. ATRA does not inhibit melanogenesis in skin equivalent or monolayer cultures of melanocytes, whereas it enhances the pigmentation of low-melanized melanoma cells and decreased that of highly pigmented normal melanocytes after UV-irradiation (30).

*Tazarotene.* This acetylenic topical retinoid improves the irregular hyperpigmentation associated with photoaging and lightening the pigmented spots.

Tazarotene 0.1% gel is associated with reduced mottling on the dorsal aspects of forearms. The Fontana stain showed a moderate to marked depigmenting effect with decreased pigmentation on the tazarotene treated side. Melanin granules were sparser and less heavily pigmented explaining probably the bleaching of hyperpigmented spots (31).

*Adapalene.* Adapalene gel 0.1% and 0.3%, a synthetic retinoid, improves solar lentigines as well as other features of photodamaged skin and is well tolerated (32).

#### *Liquorice Extracts*

Liquiritin, a flavonoid glycoside of liquorice, has been found to induce a significant improvement of hypermelanosis in patients with bilateral epidermal melasma (33). The mechanism proposed involved melanin dispersion and increased epidermal turnover. Glabridin, the main component of hydrophobic fraction of liquorice extracts, decreases tyrosinase activity in melanoma cells. Furthermore, this compound inhibits UVB-induced skin pigmentation (34). Although no clinical trials exist to evaluate its efficacy as depigmenting agent, one available glabridin may be found in some cosmetics.

#### *Thioctic Acid ( $\alpha$ -Lipoic Acid)*

This compound is a disulfide derivative of octanoic acid. It acts as ROS scavenger and Redox regulator but also inhibits tyrosinase activity probably by chelating the cooper ions and prevents UV-induced photoactive damage (35). This product is commercially available.



### Unsaturated Fatty Acids

Oleic acid (C18:1), linoleic acid (C18:2), and  $\alpha$ -linolenic acid (C18:3) suppress pigmentation *in vitro*. Some of these compounds have *in vivo* a lightening effect in UVB-induced pigmentation without toxic effects on melanocytes (36). Fatty acids have been shown recently to regulate pigmentation via proteosomal degradation (37). Linoleic acid accelerates the degradation of tyrosinase, thus inhibiting melanogenesis. In contrast, palmitic acid, a saturated fatty acid, retards the proteolysis of and thus accelerates melanogenesis.

### Inhibitory Oligopeptides

A short-sequence oligopeptides (10 amino acids) (Lumixyl) with inhibitory activity against mushroom and human tyrosinase (Elixir Institute of Regenerative Medicine, San Jose, California, U.S.) has been identified in a library. This oligopeptide showed no cytotoxicity to human melanocytes. Only a split-face double-blind, randomized and placebo-controlled evaluation including five female participants with moderate melasma has been performed. The results of this clinical trial were positive. However, this oligopeptide warrants further evaluation (38,39).

### Combination Therapies

They are widely used for the treatment of hypermelanoses. The purpose of these strategies is to augment the efficacy by associating active ingredients with different mode of action to obtain a synergic effect, to shorten the duration of therapy, and to reduce the risk of adverse effects.

**Kligman's formula.** The most popular combination treatment for depigmenting skin is the Kligman's formula. This polytherapy includes 5% HQ, 0.1% tretinoin, and 0.1% dexamethasone in a hydrophilic ointment. Tretinoin functions as an enhancer of HQ penetration in the epidermis. Furthermore, tretinoin increases epidermal turnover, thus facilitating melanin dispersion within keratinocytes and also melanin removal from corneocyte shedding. Dexamethasone decreases the irritation and inflammation caused by HQ and/or tretinoin and the melanin synthesis by inhibiting metabolic activity. This formula demonstrated an efficacy in the treatment of melasma, ephelides, and post-inflammatory hypermelanosis. Depigmentation occurs rapidly, beginning within three weeks after twice daily application. Unfortunately, the efficacy of this formula depends on its stability. Extemporaneous formulation is useful, but bears a strong risk of instability. Recently, a stabilized formulation containing 4% HQ, 0.05% tretinoine, and 0.01% fluocinolone acetonide has been launched. Two multicenter, randomized double-blind controlled trials demonstrated the safety and efficacy of this combination treatment in patients with moderate to severe melasma (40). After eight weeks of treatment, a 75% reduction of melasma was found in more than 70% of the patients. Furthermore, a superiority of the formulation over its three components (HQ, tretinoine, fluocinolone acetonide) was demonstrated. There are already many variants of the extemporaneous Kligman's formula. The suggestion that topical steroids are not necessary for achieving depigmentation led to a modification of this formula by removing topical steroids. Clinical trials demonstrated that 2% HQ combined to 0.05% to 1% tretinoin cream and lotions are also effective.

**4-Hydroxyanisole + tretinoine (Mequinol<sup>®</sup>).** A solution containing monomethyl ether of HQ (2%) and tretinoin 0.01% has been launched in North America for the treatment of actinic lentigo. This combination treatment has been shown to improve

the appearance of these lesions in several controlled and non-controlled studies (41,42).

**Azelaic acid + Tretinoin.** A combination regimen of 20% AA with topical tretinoin 0.05% produces an earlier and more pronounced lightening pigmentation during the early phase of the treatment. However, an equivalent efficacy of the combination 20% AA-topical tretinoin 0.05% versus AA monotherapy was obtained after six months of treatment (43). 20% AA has also been associated with 15% to 20% glycolic acid lotion. This combination regimen was as effective as 4% HQ cream for the treatment of facial hyperpigmentation in dark-skinned individuals (44).

**HQ + KA.** Kojic acid has also been included in combination regimens. 2% kojic acid in a gel containing 10% glycolic acid and 2% HQ improves epidermal melasma after 12 weeks of treatment, 1% to 4% kojic acid combined with tretinoin, HQ, and/or corticosteroid or glycolic acid appears to act synergistically (45).

**Westerhof formula.** The combination of 4.7% N-acetylcystein (NAC), 2% HQ, and 0.1% triamcinolone acetonide has been demonstrated to be effective in the treatment of melasma. The mechanism of action of NAC is not fully characterized. NAC exerts an inhibitory effect on tyrosinase. However, it is likely the NAC stimulates pheomelanogenesis rather than eumelanogenesis, clinically producing lighter color.

### Cosmetic Use of Bleaching Products

It is a common practice in dark-skinned women from sub-Saharan Africa and a few other parts of the world. The products used include HQ, potent or super-potent topical glucocorticoids, mercury, salts, and caustic agents such as liquid soaps, hydrogen peroxide, and salicylic preparations. Most users (>90%) apply the products once or twice daily to the whole body, during months or years. Side effects, often very severe, include skin atrophy, delayed cicatrization, infectious dermatoses (bacteriae, mycoses, parasites), acne, dyschromia with a typical pattern, irritant and allergic contact dermatitis, prominent striae, ochronosis, poikiloderma of the neck and periocular hyperchromia (Fig. 37.2). Nephrotic syndrome can



**Figure 37.2** Exogenous ochronosis due to chronic application of hydroquinone.

be observed after the use of mercurial derivatives. Finally, the daily use of potent topical steroids during years can lead to Cushing syndrome. This practice is a real health problem, not only in Africa but also in Northern countries receiving large immigrant communities. A careful dermatological examination of patients is helpful to detect the skin symptoms resulting from this practice (46).

### Chemical Peels

Chemabrasion and peels using various chemicals is another treatment modalities for removal of freckles, actinic lentiginos and other pigmented spots, melasma, and post-inflammatory hypermelanosis. Deep peels are avoided in patients with hypermelanosis because of the high risk of post-inflammatory hyper or hypomelanosis, scarring, and keloid formation. Mainly superficial and medium depth chemical peels have been used for the treatment of hypermelanosis, mainly in fair-skinned individuals.

Glycolic acid is an  $\alpha$ -hydroxy acid that has an epidermal dis cohesive effect at low concentrations. Removal corneocytes and epidermal upper layers keratinocytes by chemical peeling reduces the epidermal melanin content and improves hypermelanoses. Glycolic acid peels (50% to 70%) are becoming increasingly popular in the treatment of melasma. They can be safely used in dark-skinned patients because of a quite low risk of hyperpigmentation (47).

A few studies have demonstrated the efficacy of chemical peels with other depigmenting agents in patients with hypermelanosis. Complete bleaching of diffuse melasma was observed in patients (30%) treated with glycolic acid 50% plus kojic acid 10% and partial blanching in 60% of patients (45). Serial glycolic acid peels (30–40%) combined with a modified Kligman formula (2% HQ + 0.05% tretinoin + 1% hydrocortisone) provided an additional effect to the standard topical treatment in dark-skinned patients with melasma. Another study suggested that daily application of 10% glycolic acid lotion and 2% HQ combined with 70% glycolic acid peels every three weeks showed some improvement of pigmented spots of photoaging in Asian women (48). In contrast, a split-face prospective study in 21 Hispanic women within melasma showed no differences in the bleaching effect of 4% HQ + glycolic peels 20% to 30% versus HQ 4% alone.

Five peelings with salicylic acid 20% to 30% at two weeks intervals in dark-skinned patients (phototypes V to VI), after initial treatment with HQ 5% for two weeks, gave good results for melasma and other types of pigmentation (49).

The use of trichloroacetic 20% to 35% followed by HQ hydroalcoholic 4% solution or tretinoine 0.05% plus hydrocortisone acetate 1% cream has produced excellent results for hypermelanosis in white patients with higher complexions (47).

Resorcinol is used in Jessner's solution (14 g resorcinol, 14 g salicylic acid, 14 g lactic acid 85%, and enough ethanol to make up 10 mL) or in Unna's paste (up to 10% resorcinol plus zinc oxide and ceisatile) and has also been demonstrated to be effective in hypermelanosis with an acceptable rate of adverse effects.

Peels that combine kojic acid, salicylic acid,  $\alpha$ -hydroxy preparations with or without HQ or resorcinol are commercially available (47). Applied every three weeks they do not require neutralization.

### Dermabrasion

Dermabrasion using rotary diamond fraises has been used for the treatment of melasma. Patients were followed for about five years (50). According to the authors, most patients (97%)

obtained a persistent clearance of melasma and only 12 out of 410 have a partial recurrence. Only 2 patients developed hypertrophic scars and one patient had permanent hypomelanosis.

Dermabrasion-induced PIH common in Asian and dark-skinned individuals limits considerably the use of this strategy in these groups of patients. Even the more superficial microdermabrasion using a device emitting aluminium oxide crystals bears also an important risk of post-inflammatory dyspigmentation.

### Liquid Nitrogen Cryotherapy

Melanocytes are particularly susceptible to freezing, and hence they should be avoided in dark-skinned people because of the risk of permanent depigmentation. The freezing agent must be applied gently to avoid blistering and skin necrosis. Cryotherapy with liquid nitrogen is commonly used successfully to treat individual pigmented lesions. Although satisfactory results are common, cryotherapy for benign epidermal lesion is problematic because of hypopigmentation, hyperpigmentation atrophy, scarring, and/or frequent recurrence.

Liquid nitrogen cryotherapy has also been used for the treatment of nevus of Ota, delayed nevus spilus, and blue nevus. The cryotreatment was performed using a liquid nitrogen cryogenic instrument with a removable disk-shaped copper tip called CRYO-MINI.

Liquid nitrogen has been proposed for the treatment of hypermelanoses (actinic lentigo and other pigmented spots of photodamaged skin, Ota's nevus) and hypomelanosis (idiopathic guttate hypomelanosis).

### LASERS AND PHOTOTHERAPY

The treatment of pigmentary disorders by lasers is based on the selective photothermolysis (51). To have a selective action, the length of the laser impulsion has to be at least 10 times shorter than the relaxation time of the target. This relaxation time is proportional to the size of the target (but also depends on the shape and the diffusivity of the target). For pigmentary troubles due to melanin defects the target is the melanosome. It is a lysosome-related organelle specific of the melanocytes within the melanin is produced. With their maturation, the melanosomes will be progressively filled with melanin and be transferred to the surrounding keratinocytes (52). The size of a melanosome is about 1  $\mu$ m. Its relaxation time varies from 1 to 10  $\mu$ s. Thus, the impulsion time of the laser has to be inferior to 100 ns. The lasers that are used for pigmentary disorders are Q-switched and their impulsion length is from 10 to 100 ns allowing them to target the melanosomes and most of the exogenous pigments.

The location of the pigment in the dermis or the epidermis guides in part the choice of the wavelength. Thus, dermal pigmentation will be better treated with 1064 nm Nd:YAG lasers which wavelength could penetrate deeper in the skin tissue. Those lasers are also preferred for dark-skinned people as they less interact with the melanin of the superficial layers of the skin.

The type of pigment has also to be taken into consideration. Pheomelanin is a good target for 532 nm Nd:YAG lasers when it is a less interesting chromophore for 694, 755, and 1064 nm lasers (53). The choice of the laser wavelength is even more important for the treatment of tattoos.

All lasers can induce side effects and the patients have to be clearly informed about those potential risks. If scars are exceptional and are due to excessive fluencies, PIH is the most common side effect. PIH are mostly observed in dark phototypes. Photoprotection is required after the laser session to decrease this risk.

PIH usually regressed in a couple of weeks or months. Topical steroid eventually combined with HQ could be helpful. Leukodermas are less frequently observed. They are usually transient but permanent leukodermas have been reported mainly with 694 nm ruby lasers. The treatment of tattoos leads to more side effects. Cicatricial scars and leukoderma are more frequently observed. Patients and physicians have to be aware of the risk of paradoxical darkening of tattoos after a first session. Finally, allergic or granulomatous reactions, koebner phenomenon, and pseudolymphomas have been also reported.

Both ultraviolet (UV) A and B phototherapies are widely used in dermatology. UVA radiation includes electromagnetic waves with wavelengths between 320 and 400 nm. UVB wavelengths are between 290 and 320 nm. It is used with systemic or topical psoralens, which selectively absorbs the radiation (PUVA therapy). The main action of PUVA on biological systems is the inhibition of DNA synthesis due to photoadducts formed between psoralen and pyrimidine bases in the nucleic acid. PUVA was for a long time considered to be the phototherapy of choice, including for hypochromic disorders such as vitiligo. Its potential side-effects, including cutaneous cancers, many authors now recommend the use of UVB therapy instead (54–57). Prospective studies and meta-analysis have now showed that narrowband UVB (NB-UVB) therapy (around 311 nm) is superior to PUVA for treating vitiligo (58,59).

The 308 nm excimer lasers are used in dermatology since 1997 (60). The development of 308 nm excimer lamps is more recent. At the difference of the lasers, the wavelength is not strictly monochromatic and the beam of light is not coherent but those systems are much less expensive than lasers. Those devices emit a wavelength in the UVB spectrum. The wavelength at 308 nm provides photobiological effects theoretically superior for those devices as compared to NB-UVB, especially for their immunologic effects. Indeed, 308 nm is the most effective wavelength to induce lesions to the lymphocyte DNA, and the dose required to induce the apoptosis of lymphocytes is clearly lower with 308 nm as compared with NB-UVB (61,62). However, in vitiligo and more clearly for the other hypopigmentary disorders, the stimulation of the migration and the proliferation of melanocytes appear to have a key role, but fundamental data to compare the respective photobiological propigmenting properties of the 308 nm and NB-UVB wavelengths are still not available. The use of the 308 nm excimer laser and lamps is approved by the FDA (Food and Drug Administration) for the treatment of vitiligo.

The 632.8 nm helium neon laser is the first device that is not using the UV spectrum to repigment hypochromic lesions and especially vitiligo. Indeed, this laser that emits a wavelength in the red visible light was proven to enhance the proliferation and the differentiation of melanoblasts to mature melanocytes *in vitro* (63). It has also been demonstrated that this laser acts on mitochondria to increase the proliferation rate of the cells (64). These photobiological effects could explain, at least in part, the action of the 632.8 nm helium neon laser in repigmenting vitiligo. However, clinical data are still very poor concerning the efficacy of this device in hypochromic disorders.

## SURGICAL APPROACHES

Surgical approaches (65) aim to reconstitute the epidermal (and perhaps follicular) compartment of the melanocyte population of the skin by bringing to the hypochromic lesion, after dermabrasion, a new pigmented skin or a suspension of melanocytes,

isolated or associated with other epidermal cells such as keratinocytes. For vitiligo, such methods are usually considered for stable and localized lesions after medical treatment have failed. However, for piebaldism or in a lesser extent for nevus depigmentosus, they are almost the only one treatment available.

Several methods are available including punch grafts, blister grafts, split-thickness grafts, and autologous transplantation of melanocyte suspensions, cultured melanocytes or cultured epidermal grafts including melanocytes. Grafting of follicular melanocytes to repigment vitiligo leukotrichia has also been performed successfully (66).

Punch grafting (1.2–3 mm punch biopsies) is the simplest technique and grafts are implanted into perforations prepared at the recipient sites by different techniques (punch biopsy, ablative lasers). Minigrafting using small grafts (1.2 mm) is the best technique. The potential side effects include spotted pigmentation, polka dot appearance, color mismatch, a cobblestone effect, sinking pits, and scarring. Furthermore, this technique is time consuming.

Split thickness grafting is obtained by a standard or an electrical dermatome. The main advantage of this treatment is to allow treatment of large areas. Esthetical results are often satisfactory with a homogenous repigmentation. However, this approach may be associated with esthetically unacceptable results at the donor site (dyspigmentation, scarring). Adverse events include miliae-like cysts formation at the recipient site, partial loss of the grafts, hematoma formation, and thickening of the graft margins.

In the flip-top transplantation, the epidermis at the recipient site is not but rather used to form multiple hinged flaps, each covering an ultra thin 1.2 mm graft harvested from the donor site using a razor blade (67).

Autologous blisters can be induced by different ways: vacuum, liquid nitrogen. The mechanical split occurs at the dermoepidermal junction. The recipient site is prepared by dermabrasion, laser ablation (erbium:YAG or carbon dioxide laser), liquid nitrogen, or PUVA-induced blisters, dermatome. The graft (top of the blister) is applied and secured on the recipient site. The only adverse event is transient hyperpigmentation at both the donor and recipient sites. The advantages of this technique are the absence of scarring and the possibility of reusing the donor site. Split-thickness grafting and blister grafts give better success rate than punch grafting (68). Those techniques are not expensive and can be done in private practice.

The use of epidermal suspension (melanocytes alone or combined with keratinocytes) is more recent. Noncultured keratinocyte/melanocyte suspensions can be obtained after trypsinization of a shave biopsy of the buttock or full thickness biopsy of the scalp. Melanocytes obtained from the hair follicles and interfollicular epidermis as well as keratinocytes are placed into a suspension with patient's serum for direct application to the recipient site without expansion in culture (69). The recipient site is prepared with a dermabrasion using a dermatome or an ablative CO<sub>2</sub> or Erbium laser. This technique allows treating large lesional surfaces with a small piece of skin as a ratio of 1:10 and is commonly used. A prospective randomized double-blind study has demonstrated that epidermal suspension followed by UV (PUVA or NB-UVB) was more effective than UV only combined with dermabrasion and serum (70). However, this technique requires a specialized laboratory with trained physicians. Recently, ready to use kits have been developed but they remain expensive (71).

The number of melanocytes (combined or not with keratinocytes) can be extended in culture before grafting. Applied on vitiligo lesions, it gives satisfactory results in 30% to 44% of patients. Improvement of melanocyte culture conditions and grafting devices have made possible the transplantation of autologous cultured melanocytes on large areas (up to 500 cm<sup>2</sup> during one session) of vitiligo involved skin (72,73). A 95% repigmentation is obtained in approximately 40% of the treated areas. However, while the results are usually excellent for stable vitiligos, active forms lead to failure of the procedure and careful selection of the patients remain crucial (74). All the techniques involving melanocytes culture and epidermal reconstruction require specialized laboratory expertise and are very expensive. For these reasons, they are not widely used.

## CAMOUFLAGING

Camouflaging has been shown to increase the quality of life (DLQI) of people using it (75). The use of medical makeup has been progressively become more popular and is now integrated in many dermatological centers. Cosmetic products with high concentration in pigments allow very interesting and esthetical results but require training of the technique (76,77). A siliconated spray could be used to cover the makeup and to increase its waterproofing properties allowing the practice of water activities (78).

Dihydroxyacetone (DHA) can also be very useful to decrease the contrast of hypopigmented lesions with the surrounding skin. The brown color is due to the chemical combination of the DHA with the amino acids of the skin leading to the formation of polymeric pigments called melanoidins. Those pigments remain in the stratum corneum until desquamation of the corneocytes. The coloration appears a few hours after the application of the DHA and progressively fade after five to seven days (79–81). The main advantages of such procedure are to resist to water and not to stain the dressings. It is mainly used for the hands and the feet. Concentrations between 2.5% and 10% can be used depending on the intensity of the desired color. As DHA combined with the amino acids of the stratum corneum, the intensity of the reaction depends on the thickness of this skin layer. Thus, patients should be aware of applying less quantity on locations with thick stratum corneum such as palms, soles, knees, or ankles. The patient would also have to be informed that the pigmentation produced is not photoprotective against the UV.

Micropigmentation could also be helpful especially for areas such as lips or (mamellons) in dark-skinned phototypes (82,83).

## TREATMENT OF PIGMENTARY LESIONS

### Melasma

The gold standard treatment for melasma is topical bleaching agents (Fig. 37.3). The Kligman's formula is the most effective treatment especially in its stabilized form (40,84–87). Peeling and dermabrasion can be also proposed but their efficacy is inconstant and these strategies frequently induce PIH (52,88). Ablative and nonablative fractional lasers have been reported to improve melasma (89,90). However, recent reports showed that such approach, although interesting, was not superior to conventional therapies (91). Pigmentary lasers such as Q-switched ruby, alexandrite, or Nd:YAG lasers induce almost

constant PIH and frequent relapses. Thus, such lasers are usually not recommended for the treatment of melasma (52). Intense pulsed light (IPL) has shown some efficacy in the treatment of melasma (92–95). The risk of PIH remains important but appears to be lower than the one observed with Q-switched lasers. Topical bleaching preparations, frequently containing HQ, have been used with IPL to prevent PIH (96,97). Although potentially useful, this association approach has never been compared to bleaching cream used in monotherapy. Recent data showed that additionally to the increase in pigmentation, melasma lesions have more elastosis and vascularization, as compared to the perilesional skin (98–100). The association of a fixed triple combination cream and a pulsed dye laser (PDL) with vascular and pigmentary parameters showed significant better decrease of the hyperpigmentation of melasma and reduce the relapses observed after the summer (Passeron T. et al., submitted). Those data need to be confirmed but suggest the interest of using PDL to target all the component of this complex dermatosis.

### Vitiligo

Many medical or surgical treatments are available but only a few have clearly demonstrated their efficacy in treating vitiligo.

Phototherapy (PUVA or NB-UVB) is the gold standard for generalized forms (59,101,102). If available, NB-UVB has to be preferred to PUVA as it leads to a greater efficacy with lesser side effects and better tolerance (58).

Meta-analysis showed that class 3 topical steroids should be used in first place for localized forms of vitiligo (59,101,102). Tacrolimus 01% ointment applied twice daily showed similar efficacy than topical steroid but with fewer side effects such as telangiectasias or skin atrophy (103–107). Best results are obtained on the face and the neck. Similar results have been published with pimecrolimus 1% cream (108,109).

Targeted phototherapy with 308 nm excimer lamps and lasers are also effective for localized forms, but they are more expensive (Fig. 37.4) (110–115). However, bony prominences and extremities remains extremely difficult to treat (114).

The data concerning the others therapeutic approaches including antioxidants or topical vitamin D are more controversial (116–125).

Combination approaches associating tacrolimus ointment or pimecrolimus cream with phototherapy (308 nm excimer light or NB-UVB) have shown their superiority to monotherapy (126–131). More recently, such a synergic effect has been also reported with the association of topical steroids and UVB (132). Those associations have to be proposed for difficult-to-treat areas such as bony prominences.

Surgical treatment is a good option for localized or segmental forms that are stable for at least three years (52,59,102).

When treatments have failed corrective cosmetics, use of DHA (dihydroxyacetone 1,3-dihydroxydimethylcetone) or dermopigmentation (especially for nipples and mucosal areas) could be very useful (52,133). Finally, depigmentation that we would like as permanent can be proposed usually for people of more than 40-year-old and after detailed information is given to the patient. Psychological evaluation is also useful. The MBEH causes a permanent depigmentation of the skin that has been used for generalized vitiligo. However, the side effects that include irritant and allergic contact dermatitis, post-inflammatory hypermelanosis, leukoderma en confetti at treated sites and hypomelanosis at sites distant from the application areas



**Figure 37.3** Melasma before treatment in direct light (A) and UV light (B), and after three months of Kligman's preparation in direct light (C) and UV light (D).



**Figure 37.4** Vitiligo of the face (A). Clinical aspect after 40 sessions of 308 nm excimer laser (B) and 18 months after the end of the treatment (C).

strongly limit the use of this compound and prompted the clinicians for therapeutic alternatives. Q-switched lasers are as effective as MBEH with fewer side effects and should now be preferred (Fig. 37.5) (134–136). They should be reserved for limited surfaces and they should not be proposed if depigmentation involves less than 50% of the affected area. In all the cases, patients have to be clearly informed of the potential risk of later repigmentation and photoprotection of the treated areas should be systematically prescribed.

#### **Halo Nevus**

Halo nevi usually do not require any treatment. However, some patients are seeking for a treatment. Some successes have been reported with the 308 nm excimer laser (137).

#### **Piebaldism**

Piebaldism is a rare autosomal dominant disorder with congenital hypomelanosis. Most of the patients have a mutation in the KIT gene (138). The pigmentary disorder is limited to hair and skin without neurological, ocular, or hearing defect. The

topographical distribution of the lesions, spreading to the anterior part of the trunk, abdomen, extremities, and the frontal part of the scalp, is characteristic of the disease (139,140). Contrarily to vitiligo, these patches are congenital, stable with time, and do not repigment. Nice results can be obtained with surgical grafting procedures (141–143).

#### **Nevus Depigmentosus**

Nevus depigmentosus could be effectively treated with grafting (144,145). Late recurrences are possible and the patient should be informed about this potential risk (146). More recently, the 308 nm excimer laser has been proposed but data are still limited (147).

#### **Solar Lentigines**

Solar lentigines are effectively treated with topical blanching cream, liquid nitrogen, Q-switched lasers, and IPL (Fig. 37.6). The treatment with Q-switched laser has been proven to be the most effective approach, especially if the lesions are numerous but it remains more expensive (148). One or two laser sessions



**Figure 37.5** Extensive vitiligo of the face that did not respond to repigmenting therapies (A). Depigmentation of the remaining pigmented areas two months after one session of 755 nm alexandrite Q-switched laser (B).



**Figure 37.6** Actinic lentigos of the face (A). Clinical aspect one month after one session of 755 nm alexandrite Q-switched laser (B).

are sufficient (149). While 694 and 755 nm are usually preferred in most cases, light lentigos are better treated with 532 nm Q-switched lasers. The use of sunscreens will be advised in all patients to decrease the recurrences. If the lesion is atypical, a skin biopsy has to be performed to detect a lentigo maligna.

**Pigmented Seborrheic Keratosis**

Thin pigmented seborrheic dermatosis can be treated with Q-switched lasers and IPL but shaving or liquid nitrogen remains the most used treatments.

**Ota Nevus**

Ota nevi are dermal hypermelanocytosis of the periorbital region. Such dermal hypermelanocytosis can also affect the shoulder (Ito nevus) or rarely other parts of the body. Acquired dermal hypermelanocytosis is also reported (Fig. 37.7). Although more observed in Asian people, it affects all races. Ruby, alexandrite, and Nd:YAG Q-switched lasers have shown their efficacy. The depth of the target pigment leads to the use of longer wavelength. The 1064 nm Q-switched Nd:YAG has shown its superiority on the 755 nm alexandrite (150). Early treatment of the children and brown rather than blue lesions are good predictive factors of response to treatment (151,152). Relapses can be observed and patients have to be aware of (153).

Although literature is poor, Ito nevus and acquired dermal hypermelanocytosis can also be effectively treated with those lasers.

**Poikiloderma of Civatte**

Laser and IPL approaches are the best treatments for the poikiloderma of Civatte. Both PDL and IPL have shown their efficacy (154–157). However, persistent depigmentation has been reported as a late adverse event and high fluencies should be avoided in this fragile location (158). More recently, some authors suggested the use of fractional photothermolysis with interesting results, but the data remain limited (159,160).



**Figure 37.7** Acquired Ota nevus (Hori nevus).

**Café Au Lait Macules**

Café au lait macules can be treated with lasers and IPL. The response is although variable and recurrences are frequent. No clinical or histological markers have been determined to predict the response to treatment (161). Thus, the patient should be clearly informed of those risks. For large lesions, we advise to make a test session on a small area and to see the patient after one summer to evaluate the response and the stability after treatment before treating the entire lesion.

**Nevus Spilus**

Q-switched lasers including ruby and alexandrite have demonstrated their efficacy to treat nevus spilus (162,163). As for café au lait macules, relapses could be observed. Moreover, the risk of melanoma, even rare, is real, and laser treatment should be proposed with caution and a biopsy has to be done if the lesion is atypical.

**Lentiginos and Freckles**

Q-switched lasers are effective to treat lentiginos, including those associated with a genetic disorder such as Peutz–Jeghers–Touraine syndrome (164).

Freckles can also be treated with laser but relapses are common. As they contain mainly pheomelanin, the optimal wavelength will be the 532 nm (53,165).

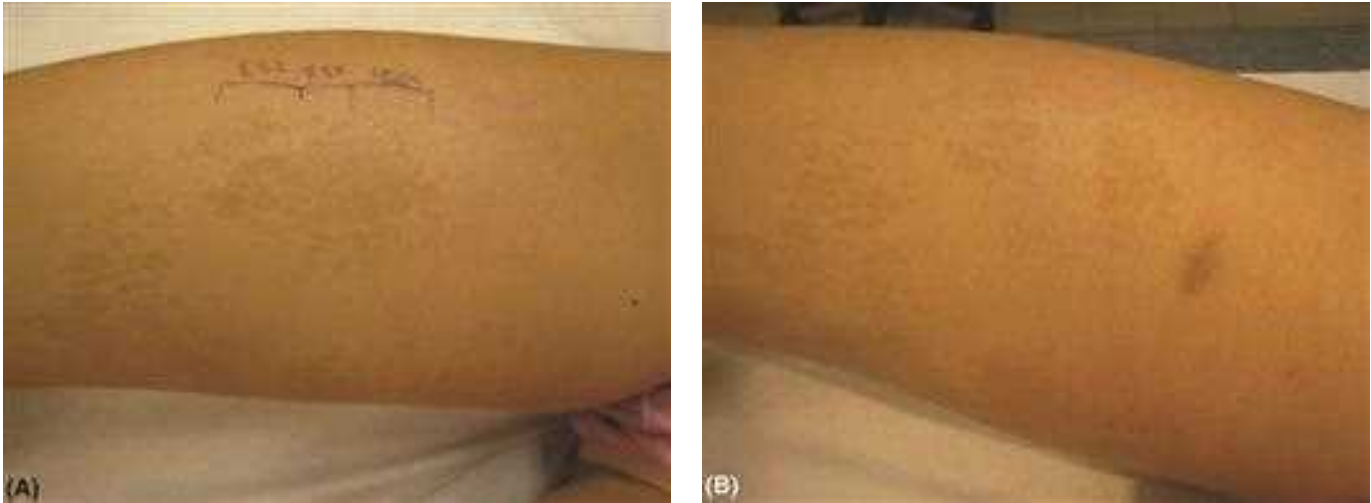
**Becker Nevus**

The hair component of Becker nevus responds well to laser hair removal (Fig. 37.8). The hyperpigmentation can also be treated with Q-switched lasers but the response is more inconstant and recurrences are observed. A test session is required before treating large lesions. Most of the authors advise to first treat the hair component but the sequence of treatment does not change the final result, and the choice mainly depends on the requests of the patient.



**Figure 37.8** Becker nevus.





**Figure 37.9** Pigmentary mosaicism of a thigh. A part of the lesion was chosen for the test session with 532, 755, and 1064 nm Q-switched lasers (A). Two months after the test session only the area treated with the 755 nm laser showed a nice improvement in this case, emphasizing the importance of testing several wavelengths in such pigmentary disorders (B).

### Pigmentary Mosaicism

There is almost no data concerning the treatment of pigmentary mosaicism. In our experience, blanching products are ineffective and only Q-switched lasers have provided some interesting results (Fig. 37.9). However, pigmentary mosaicism is a heterogeneous group, and response to treatment is highly variable. A test session using several wavelengths is required to determine the optimal laser approach and the risk of recurrences.

### Dark Rings

The dark rings under the eyes are a heterogeneous group with multifactorial etiologies that depends mainly on physiological factors such as superficial location of vasculature, periorbital edema, and shadowing due to skin laxity. In some patient, the dark rings are due to hypermelanosis mainly in dermis. Topical treatments including tretinoin cream, peeling, CO<sub>2</sub> laser, and surgical approaches have been reported (166–169). However, best results are usually obtained with Q-switched lasers and IPL (170,171).

### Pigmentation Due to Stasis Dermatitis

The pigmentation due to stasis dermatitis could be very anesthetic. Although the data are still limited, treatment with Q-switched lasers and IPL appear to be effective (172).

### Drug-Induced Pigmentations

Pigmentation induced by drugs (such as cyclines or amiodarone) can be removed with Q-switched lasers (173–175). The pigmentation is usually in the dermis so 694, 755, and 1064 nm wavelength should be preferred to Nd:YAG 532 nm.

### Post-Inflammatory Pigmentation

Post-inflammatory pigmentation is frequent and can be observed after a surgical or cosmetical procedure. Laser treatments are not

a good option for such hyperpigmentation as they can worsen the lesions. Photoprotection and treatment of the underlying dermatosis, if there is one, is mandatory and could be effective by themselves. If needed, class 3 topical steroids alone or combined with 4% to 10% HQ can be added.

### Idiopathic Guttate Hypomelanosis

Idiopathic guttate hypomelanosis are associated with the chronic sun exposure (Fig. 37.10). Any phototherapy even focused treatment with the 308 nm excimer laser or lamp should be avoided. Some isolated successes have been reported with topical tretinoin, liquid nitrogen, or localized superficial dermabrasion treatments (176–178). We recently showed that dermabrasion using erbium laser is a rapid, sure, and effective approach (T. Passeron et al., unpublished data).

### Hypopigmented Striae and Iatrogenic Leukoderma

Although quite frequent those two conditions do not have effective treatment. Isolated cases reported some successes with the 308 nm excimer laser (179–181). The absence of a group of control, the weaknesses in the evaluation of the results, and the need of maintenance sessions should moderate those results.

### Progressive Macular Hypomelanosis

Progressive macular hypomelanosis (PMH) is a common skin disorder that is often misdiagnosed (mostly for pityriasis versicolor) (Figs. 37.11 and 37.12). PMH is characterized by ill-defined nummular, nonscaly hypopigmented spots on the trunk, often confluent in and around the midline, and rarely extending to the proximal extremities and neck/head region. There is no itch, pain, or preceding inflammation. Westerhof et al. suggested the causative role of *Propionibacterium acnes* bacteria and thus proposed as a treatment the application



**Figure 37.10** Idiopathic guttate hypomelanosis.



**Figure 37.12** Achromic tinea versicolor.



**Figure 37.11** Progressive macular hypomelanosis.

of 1% clindamycin lotion during the daytime, 5% benzoyl peroxide gel at night time, and UVA light irradiation three times a week for a period of 12 weeks (182). However, phototherapy alone (PUVA or NB-UVB) appears also to be effective (183).

### Ochronosis

Alcaptonuria is a rare genetic disorder that leads to endogenous ochronosis. Exogenous ochronosis is much more frequent and is due to the chronic application of HQ. Most of cases are seen in dark-skinned people who seek for blanching their skin. Discontinuing HQ application of course is required. Only few data are available for the treatment; dermabrasion, CO<sub>2</sub> laser, and more recently Q-switched laser have been proposed (184–186).

### Dyskeratosis

Dyskeratosis including ichthyosis, seborrheic keratosis, dermatosis papulosa nigra, and confluent and reticulated papillomatosis of Gougerot et Carteau can lead to an hyperpigmentation.

Ictyosis is effectively treated by the daily use of emollients. The treatment of dermatosis papulosa nigra treatment is similar to seborrheic keratosis (cf. upper), electrodesiccation, Q-switched lasers, and more recently fractional photothermolysis have been reported (187–189). The confluent and reticulated papillomatosis of Gougerot et Carteau can be treated with topical agents such as tretinoin or vitamin D, but most authors agree to use minocycline (190–193).

### Chromhidrosis and Pseudochromhidrosis

Chromhidrosis and pseudochromhidrosis are rare skin disorders. Chromhidrosis refers to the excretion by the apocrine glands of sweat containing lipofuscin pigments, while the terms of pseudochromhidrosis or extrinsic chromhidrosis are used when the eccrine sweat is colored on the surface of the skin as a result of the deposit of extrinsic dyes or paints, or by the transformation by chromogenic bacteria. Only few fungi and bacteria are known to induce pseudochromhidrosis. Corynebacteria are responsible for red pseudochromhidrosis whereas *Malassezia furfur* and *Bacillus* sp. are the agents involved in the blue pseudochromhidrosis. The treatment of pseudochromhidrosis consists in removing clothes or tissues



**Figure 37.13** Blue ritual tattoos of the face (A) almost completely removed after only two sessions of Q-switched 755 nm alexandrite Q-switched laser (B).

responsible for the deposit of the extrinsic dyes or treating the chromogenic bacteria or fungi proliferation.

## TATTOOS

Tattoos are inclusions of pigments in the dermis or the hypodermis. Their cause can be traumatic, esthetic, or medical (marks for radiotherapy). The variety of the color sometimes leads to the necessity of using several wavelengths. Black pigments can be easily removed by almost all kind of Q-switched lasers. Blue and green tattoos will be treated with 755 nm alexandrite lasers while red color will be better targeted with 532 nm Nd:YAG lasers. The quantity, the quality, and the depth of the pigments in the skin and the individual responses of the patients account for the variability of the results, and the potential side effects sometimes observed.

Many Q-switched have demonstrated their efficacy to remove tattoos (194). Because of their side effects the nonfractional ablative lasers are not used anymore. The choice of the laser will be guided by the color of the tattoos. Amateur tattoos, permanent makeup, blue-black color, and monochromatic tattoos are good predictive factors of response to treatment (Fig. 37.13) (195). For traumatic tattoos, metal and asphalt origin and large size pigments appear to be more resistant to laser treatment. A two months delay between each session is usually recommended to allow the elimination of the fragmented pigments and to decrease the risk of cicatricial scars.

Some tattoos (especially cosmetic and yellow tattoos) can darken or change color after a first session. A test session on a limited area is recommended. If the tattoo changes its color, an additional treatment, eventually with changing the wavelength, usually allows removing the remaining pigments.

## REFERENCES

1. Nordlund JJ, Boissy RE, Hearing VJ, et al. *The Pigmentary System: Physiology and Pathophysiology*. New York: Oxford Univ Press, 1998:1–1025.
2. Passeron T, Mantoux F, Ortonne JP. Genetic disorders of pigmentation. *Clin Dermatol* 2005; 23(1):56–67.
3. Nordlund JJ, Boissy RE, Hearing VJ, et al. *The Pigmentary System: Physiology and Pathophysiology*. Edinburgh: Blackwell Science, 2006:1–1200.
4. Haught JM, Patel S, English JC III Xanthoderma: a clinical review. *J Am Acad Dermatol* 2007; 57(6):1051–1058.
5. Stratigos AJ, Katsambas AD. Optimal management of recalcitrant disorders of hyperpigmentation in dark-skinned patients. *Am J Clin Dermatol* 2004; 5(3):161–168.
6. Jimbow K, Obata H, Pathak MA, et al. Mechanism of depigmentation by hydroquinone. *J Invest Dermatol* 1974; 62:436–449.
7. Katsambas AD, Stratigos AJ. Depigmenting and bleaching agents: coping with hyperpigmentation. *Clin Dermatol* 2001; 19(4):483–488.
8. Briganti S, Camera E, Picardo M. Chemical and instrumental approaches to treat hyperpigmentation. *Pigment Cell Res* 2003; 16(2):101–110.

9. Khemis A, Kaiafa A, Queille-Roussel C, et al. Evaluation of efficacy and safety of rucinol serum in patients with melasma: a randomized controlled trial. *Br J Dermatol* 2007; 156(5):997-1004.
10. Bleehen SS. The treatment of hypermelanosis with 4-isopropylcatechol. *Br J Dermatol* 1976; 94(6):687-694.
11. Jimbow K. N-acetyl-4-S-cysteaminylphenol as a new type of depigmenting agent for the melanoderma of patients with melasma. *Arch Dermatol* 1991; 127(10):1528-1534.
12. Verallo-Rowell VM, Verallo V, Graupe K, et al. Double-blind comparison of azelaic acid and hydroquinone in the treatment of melasma. *Acta Derm Venereol Suppl (Stockh)* 1989; 143:58-61.
13. Paine C, Sharlow E, Liebel F, et al. An alternative approach to depigmentation by soybean extracts via inhibition of the PAR-2 pathway. *J Invest Dermatol* 2001; 116(4):587-595.
14. Nakagawa M, Kawai K, Kawai K. Contact allergy to kojic acid in skin care products. *Contact Dermatitis* 1995; 32(1):9-13.
15. Kameyama K, Sakai C, Kondoh S, et al. Inhibitory effect of magnesium L-ascorbyl-2-phosphate (VC-PMG) on melanogenesis in vitro and in vivo. *J Am Acad Dermatol* 1996; 34:29-33.
16. Huh CH, Seo KI, Park JY, et al. A randomized, double-blind, placebo-controlled trial of vitamin C iontophoresis in melasma. *Dermatology* 2003; 206(4):316-320.
17. Espinal-Perez LE, Moncada B, Castanedo-Cazares JP. A double-blind randomized trial of 5% ascorbic acid vs. 4% hydroquinone in melasma. *Int J Dermatol* 2004; 43(8):604-607.
18. Chung WC, Shi GY, Chow YH, et al. Human plasmin induces a receptor-mediated arachidonate release coupled with G proteins in endothelial cells. *Am J Physiol* 1993; 264:C271-C281.
19. Ando H, Matsui MS, Ichihashi M. Quasi-drugs developed in Japan for the prevention or treatment of hyperpigmentary disorders. *Int J Mol Sci* 2010; 11:2566-2575.
20. Sugai T. Clinical effects of arbutin in patients with chloasma. *Skin Res (Hifu)* 1992; 34:522-529.
21. Kamide R, Arase S, Takiwaki H, et al. Clinical effects of XSC-29 formulation on UV-induced pigmentation. *Nishinohon J Dermatol* 1995; 57:136-142.
22. Ichihashi M, Kobayashi A, Okuda M, et al. Effect of chamomilla extracts application on UV-induced pigmentation. *Skin Res (Hifu)* 1999; 41:475-480.
23. Kawashima M, Okuda M, Kobayashi A, et al. Inhibitory effect of chamomilla extracts on UV-induced pigmentation. *Nishinohon J Dermatol* 1999; 61:682-685.
24. Takeda K, Yokota T, Ikemoto T, et al. Inhibitory effect of a formulation containing 0.5% Magnolignan (5,5'-dipropyl-biphenyl-2,2'-diol) on UV-induced skin pigmentation. *Nishinohon J Dermatol* 2006; 68:288-292.
25. Takeda K, Arase S, Sagawa Y, et al. Clinical evaluation of the topical application of Magnolignan (5, 5'-dipropyl-biphenyl-2, 2'-diol) for hyperpigmentation on the face. *Nishinohon J Dermatol* 2006; 68:293-298.
26. Griffiths CE, Finkel LJ, Ditre CM, et al. Topical tretinoin (retinoic acid) improves melasma. A vehicle-controlled, clinical trial. *Br J Dermatol* 1993; 129(4):415-421.
27. Kimbrough-Green CK, Griffiths CE, Finkel LJ, et al. Topical retinoic acid (tretinoin) for melasma in black patients. A vehicle-controlled clinical trial. *Arch Dermatol* 1994; 130(6):727-733.
28. Rafal ES, Griffiths CE, Ditre CM, et al. Topical tretinoin (retinoic acid) treatment for liver spots associated with photodamage. *N Engl J Med* 1992; 326(6):368-374.
29. Bulengo-Ransby SM, Griffiths CE, Kimbrough-Green CK, et al. Topical tretinoin (retinoic acid) therapy for hyperpigmented lesions caused by inflammation of the skin in black patients. *N Engl J Med* 1993; 328(20):1438-1443.
30. Romero C, Aberdam E, Larnier C, et al. Retinoic acid as modulator of UVB-induced melanocyte differentiation. Involvement of the melanogenic enzymes expression. *J Cell Sci* 1994; 107(pt 4):1095-1103.
31. Sefton J, Kligman AM, Kopper SC, et al. Photodamage pilot study: a double-blind, vehicle-controlled study to assess the efficacy and safety of tazarotene 0.1% gel. *J Am Acad Dermatol* 2000; 43(4):656-663.
32. Kang S, Goldfarb MT, Weiss JS, et al. Assessment of adapalene gel for the treatment of actinic keratoses and lentigines: a randomized trial. *J Am Acad Dermatol* 2003; 49(1):83-90.
33. Amer M, Metwalli M. Topical liquiritin improves melasma. *Int J Dermatol* 2000; 39(4):299-301.
34. Yokota T, Nishio H, Kubota Y, et al. The inhibitory effect of glabridin from licorice extracts on melanogenesis and inflammation. *Pigment Cell Res* 1998; 11(6):355-361.
35. Saliou C, Kitazawa M, McLaughlin L, et al. Antioxidants modulate acute solar ultraviolet radiation-induced NF-kappa-B activation in a human keratinocyte cell line. *Free Radic Biol Med* 1999; 26(1-2):174-183.
36. Ando H, Ryu A, Hashimoto A, et al. Linoleic acid and alpha-linolenic acid lightens ultraviolet-induced hyperpigmentation of the skin. *Arch Dermatol Res* 1998; 290(7):375-381.
37. Ando H, Watabe H, Valencia JC, et al. Fatty acids regulate pigmentation via proteasomal degradation of tyrosinase: a new aspect of ubiquitin-proteasome function. *J Biol Chem* 2004; 279(15):15427-15433.
38. Hantash BM, Jimenez F. A split-face, double-blind, randomized and placebo-controlled pilot evaluation of a novel oligopeptide for the treatment of recalcitrant melasma. *J Drugs Dermatol* 2009; 8(8):732-735.
39. Ubeid AA, Zhao L, Wang Y, et al. Short-sequence oligopeptides with inhibitory activity against Mushroom and human tyrosinase. *J Invest Dermatol* 2009; 129:2242-2249.
40. Taylor SC, Torok H, Jones T, et al. Efficacy and safety of a new triple-combination agent for the treatment of facial melasma. *Cutis* 2003; 72(1):67-72.
41. Ortonne JP, Camacho F, Wainwright N, et al. Safety and efficacy of combined use of 4-hydroxyanisole (mequinol) 2% / tretinoin 0.01% solution and sunscreen in solar lentigines. *Cutis* 2004; 74(4):960-970.
42. Fleischer AB Jr., Schwartzel EH, Colby SI, et al. The combination of 2% 4-hydroxyanisole (Mequinol) and 0.01% tretinoin is effective in improving the appearance of solar lentigines and related hyperpigmented lesions in two double-blind multicenter clinical studies. *J Am Acad Dermatol* 2000; 42:459-467.
43. Graupe K, Cunliffe WJ, Gollnick HP, et al. Efficacy and safety of topical azelaic acid (20 percent cream): an overview of results from European clinical trials and experimental reports. *Cutis* 1996; 57(1 suppl):20-35.
44. Kakita LS, Lowe NJ. Azelaic acid and glycolic acid combination therapy for facial hyperpigmentation in darker-skinned patients: a clinical comparison with hydroquinone. *Clin Ther* 1998; 20(5):960-970.
45. Lim JT. Treatment of melasma using kojic acid in a gel containing hydroquinone and glycolic acid. *Dermatol Surg* 1999; 25(4):282-284.
46. Mahe A, Ly F, Aymard G, et al. Skin diseases associated with the cosmetic use of bleaching products in women from Dakar, Senegal. *Br J Dermatol* 2003; 148(3):493-500.
47. Perez-Bernal A, Munoz-Perez MA, Camacho F. Management of facial hyperpigmentation. *Am J Clin Dermatol* 2000; 1(5):261-268.
48. Lim JT, Tham SN. Glycolic acid peels in the treatment of melasma among Asian women. *Dermatol Surg* 1997; 23(3):177-179.
49. Grimes PE. The safety and efficacy of salicylic acid chemical peels in darker racial-ethnic groups. *Dermatol Surg* 1999; 25(1):18-22.
50. Kunachak S, Leelaudomlapi P, Wongwaisayawan A. Dermabrasion: a curative treatment for melasma. *Aesthetic Plast Surg* 2001; 25(2):114-117.
51. Anderson RR, Parrish JA. Selective photothermolysis: precise microsurgery by selective absorption of pulsed radiation. *Science* 1983; 220(4596):524-527.
52. Ortonne JP, Passeron T. Melanin pigmentary disorders: treatment update. *Dermatol Clin* 2005; 23(2):209-226.
53. Ye T, Pawlak A, Sarna T, et al. Different molecular constituents in pheomelanin are responsible for emission, transient absorption

- and oxygen photoconsumption. *Photochem Photobiol* 2008; 84(2): 437–443.
54. Lindelof B, Sigurgeirsson B, Tegner E, et al. PUVA and cancer risk: the Swedish follow-up study. *Br J Dermatol* 1999; 141(1): 108–112.
  55. Stern RS, Nichols KT, Vakeva LH. Malignant melanoma in patients treated for psoriasis with methoxsalen (psoralen) and ultraviolet A radiation (PUVA). *N Engl J Med* 1997; 336:1041–1045.
  56. Stern RS. The risk of melanoma in association with long-term exposure to PUVA. *J Am Acad Dermatol* 2001; 44(5):755–761.
  57. Garland CF, Garland FC, Gorham ED. Epidemiologic evidence for different roles of ultraviolet A and B radiation in melanoma mortality rates. *Ann Epidemiol* 2003; 13(6):395–404.
  58. Yones SS, Palmer RA, Garibaldinos TM, et al. Randomized double-blind trial of treatment of vitiligo: efficacy of psoralen-UV-A therapy vs Narrowband-UV-B therapy. *Arch Dermatol* 2007; 143(5):578–584.
  59. Gawkrödger DJ, Ormerod AD, Shaw L, et al. Guideline for the diagnosis and management of vitiligo. *Br J Dermatol* 2008; 159(5): 1051–1076.
  60. Bonis B, Kemeny L, Dobozy A, et al. 308 nm UVB excimer laser for psoriasis. *Lancet* 1997; 350(9090):1522.
  61. Chilbert MA, Peak MJ, Peak JG, et al. Effects of intensity and fluence upon DNA single-strand breaks induced by excimer laser radiation. *Photochem Photobiol* 1988; 47:523–525.
  62. de With A, Greulich KO. Wavelength dependence of laser-induced DNA damage in lymphocytes observed by single-cell gel electrophoresis. *J Photochem Photobiol B* 1995; 30(1):71–76.
  63. Lan CC, Wu CS, Chiou MH, et al. Low-energy helium-neon laser induces locomotion of the immature melanoblasts and promotes melanogenesis of the more differentiated melanoblasts: recapitulation of vitiligo repigmentation in vitro. *J Invest Dermatol* 2006; 126(9):2119–2126.
  64. Hu WP, Wang JJ, Yu CL, et al. Helium-neon laser irradiation stimulates cell proliferation through photostimulatory effects in mitochondria. *J Invest Dermatol* 2007; 127(8):2048–2057.
  65. Gupta S, Olson M, Kanwar AJ, et al. Surgical management of vitiligo. In: Passeron T, Ortonne JP, eds. *Medical Treatment of Vitiligo*. 1st ed. Oxford, UK: Blackwell Publishing, 2007:31–38.
  66. Na GY, Seo SK, Choi SK. Single hair grafting for the treatment of vitiligo. *J Am Acad Dermatol* 1998; 38(4):580–584.
  67. McGovern TW, Bologna J, Leffell DJ. Flip-top pigment transplantation: a novel transplantation procedure for the treatment of depigmentation. *Arch Dermatol* 1999; 135(11):1305–1307.
  68. Njoo MD, Westerhof W, Bos JD, et al. A systematic review of autologous transplantation methods in vitiligo. *Arch Dermatol* 1998; 134(12):1543–1549.
  69. Gauthier Y, Surlève-Bazeille JE. Autologous grafting with non-cultured melanocytes: a simplified method for treatment of depigmented lesions. *J Am Acad Dermatol* 1992; 26(2 pt 1):191–194.
  70. van Geel N, Ongenaë K, De Mil M, et al. Double-blind placebo-controlled study of autologous transplanted epidermal cell suspensions for repigmenting vitiligo. *Arch Dermatol* 2004; 140(10): 1203–1208.
  71. Mulekar SV, Ghwish B, Al Issa A, et al. Treatment of vitiligo lesions by ReCell vs. conventional melanocyte-keratinocyte transplantation: a pilot study. *Br J Dermatol* 2008; 158(1):45–49.
  72. Olsson MJ, Juhlin L. Melanocyte transplantation in vitiligo. *Lancet* 1992; 340(8825):981.
  73. Olsson MJ, Juhlin L. Transplantation of melanocytes in vitiligo. *Br J Dermatol* 1995; 132:587–591.
  74. Chen YF, Yang PY, Hu DN, et al. Treatment of vitiligo by transplantation of cultured pure melanocyte suspension: analysis of 120 cases. *J Am Acad Dermatol* 2004; 51:68–74.
  75. Ongenaë K, Dierckxsens L, Brochez L, et al. Quality of life and stigmatization profile in a cohort of vitiligo patients and effect of the use of camouflage. *Dermatology* 2005; 210(4):279–285.
  76. Deshayes P. [Cosmetic camouflage for a better quality of life]. *Ann Dermatol Venerol* 2008; 135(suppl 3):S208–S210.
  77. Tanioka M, Miyachi Y. Camouflage for vitiligo. *Dermatol Ther* 2009; 22(1):90–93.
  78. Tanioka M, Miyachi Y. Waterproof camouflage age for vitiligo of the face using Cavilon 3M as a spray. *Eur J Dermatol* 2008; 18(1):93–94.
  79. Hsu S. Camouflaging vitiligo with dihydroxyacetone. *Dermatol Online J* 2008; 14(8):23.
  80. Rajatanavin N, Suwanachote S, Kulkollakarn S. Dihydroxyacetone: a safe camouflaging option in vitiligo. *Int J Dermatol* 2008; 47(4):402–406.
  81. Suga Y, Ikejima A, Matsuba S, et al. DHA application for camouflaging segmental vitiligo and piebald lesions. *J Am Acad Dermatol* 2002; 47:436–438.
  82. Garg G, Thami GP. Micropigmentation: tattooing for medical purposes. *Dermatol Surg* 2005; 31(8 pt 1):928–931; discussion 931.
  83. Halder RM, Pham HN, Breadon JY, et al. Micropigmentation for the treatment of vitiligo. *J Dermatol Surg Oncol* 1989; 15(10):1092–1098.
  84. Chan R, Park KC, Lee MH, et al. A randomized controlled trial of the efficacy and safety of a fixed triple combination (fluocinolone acetonide 0.01%, hydroquinone 4%, tretinoin 0.05%) compared with hydroquinone 4% cream in Asian patients with moderate to severe melasma. *Br J Dermatol* 2008; 159(3):697–703.
  85. Ferreira Cestari T, Hassun K, Sittart A, et al. A comparison of triple combination cream and hydroquinone 4% cream for the treatment of moderate to severe facial melasma. *J Cosmet Dermatol* 2007; 6(1):36–39.
  86. Torok H, Taylor S, Baumann L, et al. A large 12-month extension study of an 8-week trial to evaluate the safety and efficacy of triple combination (TC) cream in melasma patients previously treated with TC cream or one of its dyads. *J Drugs Dermatol* 2005; 4(5):592–597.
  87. Torok HM, Jones T, Rich P, et al. Hydroquinone 4%, tretinoin 0.05%, fluocinolone acetonide 0.01%: a safe and efficacious 12-month treatment for melasma. *Cutis* 2005; 75(1):57–62.
  88. Gupta AK, Gover MD, Nouri K, et al. The treatment of melasma: a review of clinical trials. *J Am Acad Dermatol* 2006; 55(6):1048–1065.
  89. Rokhsar CK, Fitzpatrick RE. The treatment of melasma with fractional photothermolysis: a pilot study. *Dermatol Surg* 2005; 31(12):1645–1650.
  90. Tannous ZS, Astner S. Utilizing fractional resurfacing in the treatment of therapy-resistant melasma. *J Cosmet Laser Ther* 2005; 7(1):39–43.
  91. Lee HS, Won CH, Lee DH, et al. Treatment of melasma in Asian skin using a fractional 1,550-nm laser: an open clinical study. *Dermatol Surg* 2009; 35(10):1499–1504.
  92. Li YH, Chen JZ, Wei HC, et al. Efficacy and safety of intense pulsed light in treatment of melasma in Chinese patients. *Dermatol Surg* 2008; 34(5):693–700; discussion 700–701.
  93. Konishi N, Kawada A, Kawara S, et al. Clinical effectiveness of a novel intense pulsed light source on facial pigmentary lesions. *Arch Dermatol Res* 2008; 300(suppl 1):S65–S67.
  94. Chan HH, Kono T. The use of lasers and intense pulsed light sources for the treatment of pigmentary lesions. *Skin Ther Lett* 2004; 9(8):5–7.
  95. Chan H. The use of lasers and intense pulsed light sources for the treatment of acquired pigmentary lesions in Asians. *J Cosmet Laser Ther* 2003; 5(3–4):198–200.
  96. Wang CC, Hui CY, Sue YM, et al. Intense pulsed light for the treatment of refractory melasma in Asian persons. *Dermatol Surg* 2004; 30(9):1196–1200.
  97. Moreno Arias GA, Ferrando J. Intense pulsed light for melanocytic lesions. *Dermatol Surg* 2001; 27(4):397–400.
  98. Kang WH, Yoon KH, Lee ES, et al. Melasma: histopathological characteristics in 56 Korean patients. *Br J Dermatol* 2002; 146(2): 228–237.
  99. Kim EH, Kim YC, Lee ES, et al. The vascular characteristics of melasma. *J Dermatol Sci* 2007; 46(2):111–116.
  100. Hernandez-Barrera R, Torres-Alvarez B, Castaneda-Cazares JP, et al. Solar elastosis and presence of mast cells as key features in the pathogenesis of melasma. *Clin Exp Dermatol* 2008; 33(3):305–308.

101. Njoo MD, Spuls PI, Bos JD, et al. Nonsurgical repigmentation therapies in vitiligo. Meta-analysis of the literature. *Arch Dermatol* 1998; 134(12):1532-1540.
102. Whitton ME, Ashcroft DM, Gonzalez U. Therapeutic interventions for vitiligo. *J Am Acad Dermatol* 2008; 59(4):713-717.
103. Smith DA, Tofte SJ, Hanifin JM. Repigmentation of vitiligo with topical tacrolimus. *Dermatology* 2002; 205(3):301-303.
104. Grimes PE, Soriano T, Dytoc MT. Topical tacrolimus for repigmentation of vitiligo. *J Am Acad Dermatol* 2002; 47(5):789-791.
105. Travis LB, Weinberg JM, Silverberg NB. Successful treatment of vitiligo with 0.1% tacrolimus ointment. *Arch Dermatol* 2003; 139(5):571-574; discussion 573.
106. Lepe V, Moncada B, Castaneda-Cazares JP, et al. A double-blind randomized trial of 0.1% tacrolimus vs 0.05% clobetasol for the treatment of childhood vitiligo. *Arch Dermatol* 2003; 139(5):581-585.
107. Tanghetti EA. Tacrolimus ointment 0.1% produces repigmentation in patients with vitiligo: results of a prospective patient series. *Cutis* 2003; 71(2):158-162.
108. Dawid M, Veensalu M, Grassberger M, et al. Efficacy and safety of pimecrolimus cream 1% in adult patients with vitiligo: results of a randomized, double-blind, vehicle-controlled study. *J Dtsch Dermatol Ges* 2006; 4(11):942-946.
109. Coskun B, Saral Y, Turgut D. Topical 0.05% clobetasol propionate versus 1% pimecrolimus ointment in vitiligo. *Eur J Dermatol* 2005; 15(2):88-91.
110. Spencer JM, Nossa R, Ajmeri J. Treatment of vitiligo with the 308-nm excimer laser: a pilot study. *J Am Acad Dermatol* 2002; 46(5):727-731.
111. Baltas E, Csoma Z, Ignacz F, et al. Treatment of vitiligo with the 308-nm xenon chloride excimer laser. *Arch Dermatol* 2002; 138(12):1619-1620.
112. Taneja A, Trehan M, Taylor CR. 308-nm excimer laser for the treatment of localized vitiligo. *Int J Dermatol* 2003; 42(8):658-662.
113. Esposito M, Soda R, Costanzo A, et al. Treatment of vitiligo with the 308 nm excimer laser. *Clin Exp Dermatol* 2004; 29(2):133-137.
114. Ostovari N, Passeron T, Zakaria W, et al. Treatment of vitiligo by 308-nm excimer laser: an evaluation of variables affecting treatment response. *Lasers Surg Med* 2004; 35(2):152-156.
115. Leone G, Iacovelli P, Paro Vidolin A, et al. Monochromatic excimer light 308 nm in the treatment of vitiligo: a pilot study. *J Eur Acad Dermatol Venereol* 2003; 17(5):531-537.
116. Schallreuter KU, Wood JM, Lemke KR, et al. Treatment of vitiligo with a topical application of pseudocatalase and calcium in combination with short-term UVB exposure: a case study on 33 patients. *Dermatology* 1995; 190(3):223-229.
117. Patel DC, Evans AV, Hawk JL. Topical pseudocatalase mousse and narrowband UVB phototherapy is not effective for vitiligo: an open, single-centre study. *Clin Exp Dermatol* 2002; 27(8):641-644.
118. Chiaverini C, Passeron T, Ortonne JP. Treatment of vitiligo by topical calcipotriol. *J Eur Acad Dermatol Venereol* 2002; 16(2):137-138.
119. Goldinger SM, Dummer R, Schmid P, et al. Combination of 308-nm xenon chloride excimer laser and topical calcipotriol in vitiligo. *J Eur Acad Dermatol Venereol* 2007; 21(4):504-508.
120. Hartmann A, Lurz C, Hamm H, et al. Narrow-band UVB311 nm vs. broad-band UVB therapy in combination with topical calcipotriol vs. placebo in vitiligo. *Int J Dermatol* 2005; 44(9):736-742.
121. Goktas EO, Aydin F, Senturk N, et al. Combination of narrow band UVB and topical calcipotriol for the treatment of vitiligo. *J Eur Acad Dermatol Venereol* 2006; 20(5):553-557.
122. Arca E, Tařtan HB, Erbil AH, et al. Narrow-band ultraviolet B as monotherapy and in combination with topical calcipotriol in the treatment of vitiligo. *J Dermatol* 2006; 33(5):338-343.
123. Baysal V, Yildirim M, Erel A, et al. Is the combination of calcipotriol and PUVA effective in vitiligo? *J Eur Acad Dermatol Venereol* 2003; 17(3):299-302.
124. Ada S, Sahin S, Boztepe G, et al. No additional effect of topical calcipotriol on narrow-band UVB phototherapy in patients with generalized vitiligo. *Photodermatol Photoimmunol Photomed* 2005; 21(2):79-83.
125. Kose O, Riza Gur A, Kurumlu Z, et al. Calcipotriol ointment versus clobetasol ointment in localized vitiligo: an open, comparative clinical trial. *Int J Dermatol* 2002; 41(9):616-618.
126. Passeron T, Ostovari N, Zakaria W, et al. Topical tacrolimus and the 308-nm excimer laser: a synergistic combination for the treatment of vitiligo. *Arch Dermatol* 2004; 140(9):1065-1069.
127. Kawalek AZ, Spencer JM, Phelps RG. Combined excimer laser and topical tacrolimus for the treatment of vitiligo: a pilot study. *Dermatol Surg* 2004; 30(2 pt 1):130-135.
128. Tanghetti EA, Gillis PR. Clinical evaluation of B Clear and Protopic treatment for vitiligo. *Lasers Surg Med* 2003; 32(S15):37.
129. Fai D, Cassano N, Vena GA. Narrow-band UVB phototherapy combined with tacrolimus ointment in vitiligo: a review of 110 patients. *J Eur Acad Dermatol Venereol* 2007; 21(7):916-920.
130. Mehrabi D, Pandya AG. A randomized, placebo-controlled, double-blind trial comparing narrowband UV-B Plus 0.1% tacrolimus ointment with narrowband UV-B plus placebo in the treatment of generalized vitiligo. *Arch Dermatol* 2006; 142(7):927-929.
131. Hui-Lan Y, Xiao-Yan H, Jian-Yong F, et al. Combination of 308-nm excimer laser with topical pimecrolimus for the treatment of childhood vitiligo. *Pediatr Dermatol* 2009; 26(3):354-356.
132. Sassi F, Cazzaniga S, Tessari G, et al. Randomized controlled trial comparing the effectiveness of 308-nm excimer laser alone or in combination with topical hydrocortisone 17-butyrate cream in the treatment of vitiligo of the face and neck. *Br J Dermatol* 2008; 159(5):1186-1191.
133. Levy SB. Tanning preparations. *Dermatol Clin* 2000; 18(4):591-596.
134. Njoo MD, Vodegel RM, Westerhof W. Depigmentation therapy in vitiligo universalis with topical 4-methoxyphenol and the Q-switched ruby laser. *J Am Acad Dermatol* 2000; 42(5 pt 1):760-769.
135. Kim YJ, Chung BS, Choi KC. Depigmentation therapy with Q-switched ruby laser after tanning in vitiligo universalis. *Dermatol Surg* 2001; 27(11):969-970.
136. Rao J, Fitzpatrick RE. Use of the Q-switched 755-nm alexandrite laser to treat recalcitrant pigment after depigmentation therapy for vitiligo. *Dermatol Surg* 2004; 30(7):1043-1045.
137. Mulekar SV, Issa AA, Eisa AA. Treatment of halo nevus with a 308-nm excimer laser: a pilot study. *J Cosmet Laser Ther* 2007; 9(4):245-248.
138. Grabbe J, Welker P, Dippel E, et al. Stem cell factor, a novel cutaneous growth factor for mast cells and melanocytes. *Arch Dermatol Res* 1994; 287(1):78-84.
139. Mosher DB, Fitzpatrick TB. Piebaldism. *Arch Dermatol* 1988; 124(3):364-365.
140. Spritz RA. Piebaldism, Waardenburg syndrome, and related disorders of melanocyte development. *Semin Cutan Med Surg* 1997; 16(1):15-23.
141. Bondanza S, Bellini M, Roversi G, et al. Piebald trait: implication of kit mutation on in vitro melanocyte survival and on the clinical application of cultured epidermal autografts. *J Invest Dermatol* 2007; 127(3):676-686.
142. Goh BK, Chua XM, Chong KL, et al. Simplified cellular grafting for treatment of vitiligo and piebaldism: the "6-well plate" technique. *Dermatol Surg* 2010; 36(2):203-207. [Epub December 21, 2009].
143. Guerra L, Primavera G, Raskovic D, et al. Permanent repigmentation of piebaldism by erbium:YAG laser and autologous cultured epidermis. *Br J Dermatol* 2004; 150(4):715-721.
144. Gupta S, Goel A. Letter to the editor: nevus depigmentosus needs transplant of epidermal sheets. *Dermatol Surg* 2005; 31(12):1746-1747.
145. Raskovic D, Bondanza S, Gobello T, et al. Autologous in vitro reconstituted epidermis in the treatment of a large nevus depigmentosus. *J Am Acad Dermatol* 2006; 54(5 suppl):S238-S240.

146. Kim do Y, Park YK, Hann SK. Recurrence of nevus depigmentosus after an autologous epidermal graft. *J Am Acad Dermatol* 2008; 58(3):527–529.
147. Kim do Y, Lee KY, Park YK. Use of the 308-nm excimer laser for nevus depigmentosus: a promising treatment for either nevus depigmentosus or vitiligo. *J Dermatol* 2007; 34(3):217–218.
148. Todd MM, Rallis TM, Gerwels JW, et al. A comparison of 3 lasers and liquid nitrogen in the treatment of solar lentigines: a randomized, controlled, comparative trial. *Arch Dermatol* 2000; 136(7):841–846.
149. Tanzi EL, Lupton JR, Alster TS. Lasers in dermatology: four decades of progress. *J Am Acad Dermatol* 2003; 49(1):1–31; quiz 31–34.
150. Chan HH, Ying SY, Ho WS, et al. An in vivo trial comparing the clinical efficacy and complications of Q-switched 755 nm alexandrite and Q-switched 1064 nm Nd:YAG lasers in the treatment of nevus of Ota. *Dermatol Surg* 2000; 26(10):919–922.
151. Kono T, Chan HH, Erçöçen AR, et al. Use of Q-switched ruby laser in the treatment of nevus of ota in different age groups. *Lasers Surg Med* 2003; 32(5):391–395.
152. Ueda S, Isoda M, Imayama S. Response of naevus of Ota to Q-switched ruby laser treatment according to lesion colour. *Br J Dermatol* 2000; 142(1):77–83.
153. Chan HH, Leung RS, Ying SY, et al. Recurrence of nevus of Ota after successful treatment with Q-switched lasers. *Arch Dermatol* 2000; 136(9):1175–1176.
154. Batta K, Hindson C, Cotterill JA, et al. Treatment of poikiloderma of Civatte with the potassium titanyl phosphate (KTP) laser. *Br J Dermatol* 1999; 140(6):1191–1192.
155. Langeland J. Treatment of poikiloderma of Civatte with the pulsed dye laser: a series of seven cases. *J Cutan Laser Ther* 1999; 1(2):127.
156. Weiss RA, Goldman MP, Weiss MA. Treatment of poikiloderma of Civatte with an intense pulsed light source. *Dermatol Surg* 2000; 26(9):823–827; discussion 828.
157. Rusciani A, Motta A, Fino P, et al. Treatment of poikiloderma of Civatte using intense pulsed light source: 7 years of experience. *Dermatol Surg* 2008; 34(3):314–319; discussion 319.
158. Meijs MM, Blok FA, de Rie MA. Treatment of poikiloderma of Civatte with the pulsed dye laser: a series of patients with severe depigmentation. *J Eur Acad Dermatol Venereol* 2006; 20(10):1248–1251.
159. Behroozan DS, Goldberg LH, Glaich AS, et al. Fractional photothermolysis for treatment of poikiloderma of civatte. *Dermatol Surg* 2006; 32(2):298–301.
160. Tierney EP, Hanke CW. Treatment of poikiloderma of civatte with ablative fractional laser resurfacing: prospective study and review of the literature. *J Drugs Dermatol* 2009; 8(6):527–534.
161. Grossman MC, Anderson RR, Farinelli W, et al. Treatment of cafe au lait macules with lasers. A clinicopathologic correlation. *Arch Dermatol* 1995; 131(12):1416–1420.
162. Grevelink JM, González S, Bonoan R, et al. Treatment of nevus spilus with the Q-switched ruby laser. *Dermatol Surg* 1997; 23(5):365–369; discussion 369–370.
163. Moreno-Arias GA, Bulla F, Vilata-Corell JJ, et al. Treatment of widespread segmental nevus spilus by Q-switched alexandrite laser (755 nm, 100 nsec). *Dermatol Surg* 2001; 27(9):841–843.
164. Kato S, Takeyama J, Tanita Y, et al. Ruby laser therapy for labial lentigines in Peutz-Jeghers syndrome. *Eur J Pediatr* 1998; 157(8):622–624.
165. Kollias N, Baqer AH. Absorption mechanisms of human melanin in the visible, 400–720 nm. *J Invest Dermatol* 1987; 89:384–388.
166. Ditre CM, Griffin TD, Murphy GF, et al. Effects of alpha-hydroxy acids on photoaged skin: a pilot clinical, histologic, and ultrastructural study. *J Am Acad Dermatol* 1996; 34(2 pt 1):187–195.
167. Olsen EA, Katz HI, Levine N, et al. Tretinoin emollient cream for photodamaged skin: results of 48-week, multicenter, double-blind studies. *J Am Acad Dermatol* 1997; 37(2 pt 1):217–226.
168. West TB, Alster TS. Improvement of infraorbital hyperpigmentation following carbon dioxide laser resurfacing. *Dermatol Surg* 1998; 24(6):615–616.
169. Zarem HA, Resnick JI. Expanded applications for transconjunctival lower lid blepharoplasty. *Plast Reconstr Surg* 1999; 103(3):1041–1043; discussion 1044–1045.
170. Watanabe S, Nakai K, Ohnishi T. Condition known as “dark rings under the eyes” in the Japanese population is a kind of dermal melanocytosis which can be successfully treated by Q-switched ruby laser. *Dermatol Surg* 2006; 32(6):785–789; discussion 789.
171. Cymbalista NC, Prado de Oliveira ZN. Treatment of idiopathic cutaneous hyperchromia of the orbital region (ICHOR) with intense pulsed light. *Dermatol Surg* 2006; 32(6):773–783; discussion 783–784.
172. Pimentel CL, Rodriguez-Salido MJ. Pigmentation due to stasis dermatitis treated successfully with a noncoherent intense pulsed light source. *Dermatol Surg* 2008; 34(7):950–951.
173. Karrer S, Hohenleutner U, Szeimies RM, et al. Amiodarone-induced pigmentation resolves after treatment with the Q-switched ruby laser. *Arch Dermatol* 1999; 135(3):251–253.
174. Alster TS, Gupta SN. Minocycline-induced hyperpigmentation treated with a 755-nm Q-switched alexandrite laser. *Dermatol Surg* 2004; 30(9):1201–1204.
175. Collins P, Cotterill JA. Minocycline-induced pigmentation resolves after treatment with the Q-switched ruby laser. *Br J Dermatol* 1996; 135(2):317–319.
176. Hexsel DM. Treatment of idiopathic guttate hypomelanosis by localized superficial dermabrasion. *Dermatol Surg* 1999; 25(11):917–918.
177. Pagnoni A, Kligman AM, Sadiq I, et al. Hypopigmented macules of photodamaged skin and their treatment with topical tretinoin. *Acta Derm Venereol* 1999; 79(4):305–310.
178. Ploysangam T, Dee-Ananlap S, Suvanprakorn P. Treatment of idiopathic guttate hypomelanosis with liquid nitrogen: light and electron microscopic studies. *J Am Acad Dermatol* 1990; 23(4 pt 1):681–684.
179. Friedman PM, Geronemus RG. Use of the 308-nm excimer laser for postresurfacing leukoderma. *Arch Dermatol* 2001; 137(6):824–825.
180. Gundogan C, Greve B, Hausser I, et al. [Repigmentation of persistent laser-induced hypopigmentation with an excimer laser following tattoo removal]. *Hautarzt* 2004; 55(6):549–552.
181. Goldberg DJ, Sarradet D, Hussain M. 308-nm Excimer laser treatment of mature hypopigmented striae. *Dermatol Surg* 2003; 29(6):596–598; discussion 598–599.
182. Relyveld GN, Kingswijk MM, Reitsma JB, et al. Benzoyl peroxide/clindamycin/UVA is more effective than fluticasone/UVA in progressive macular hypomelanosis: a randomized study. *J Am Acad Dermatol* 2006; 55(5):836–843.
183. Chung YL, Goo B, Chung WS, et al. A case of progressive macular hypomelanosis treated with narrow-band UVB. *J Eur Acad Dermatol Venereol* 2007; 21(7):1007–1009.
184. Diven DG, Smith EB, Pupo RA, et al. Hydroquinone-induced localized exogenous ochronosis treated with dermabrasion and CO<sub>2</sub> laser. *J Dermatol Surg Oncol* 1990; 16(11):1018–1022.
185. Lang PG Jr. Probable coexisting exogenous ochronosis and mercurial pigmentation managed by dermabrasion. *J Am Acad Dermatol* 1988; 19(5 pt 2):942–946.
186. Bellew SG, Alster TS. Treatment of exogenous ochronosis with a Q-switched alexandrite (755 nm) laser. *Dermatol Surg* 2004; 30(4 pt 1):555–558.
187. Katz TM, Goldberg LH, Friedman PM. Dermatitis papulosa nigra treatment with fractional photothermolysis. *Dermatol Surg* 2009; 35(11):1840–1843.
188. Kundu RV, Joshi SS, Suh KY, et al. Comparison of electrodesiccation and potassium-titanyl-phosphate laser for treatment of dermatosis papulosa nigra. *Dermatol Surg* 2009; 35(7):1079–1083.
189. Schweiger ES, Kwasniak L, Aires DJ. Treatment of dermatosis papulosa nigra with a 1064 nm Nd:YAG laser: report of two cases. *J Cosmet Laser Ther* 2008; 10(2):120–122.

190. Bowman PH, Davis LS. Confluent and reticulated papillomatosis: response to tazarotene. *J Am Acad Dermatol* 2003; 48(5 suppl): S80-S81.
191. Davis MD, Weenig RH, Camilleri MJ. Confluent and reticulate papillomatosis (Gougerot-Carteaud syndrome): a minocycline-responsive dermatosis without evidence for yeast in pathogenesis. A study of 39 patients and a proposal of diagnostic criteria. *Br J Dermatol* 2006; 154(2):287-293.
192. Ginarte M, Fabeiro JM, Toribio J. Confluent and reticulated papillomatosis (Gougerot-Carteaud) successfully treated with tacalcitol. *J Dermatolog Treat* 2002; 13(1):27-30.
193. Schwartzberg JB, Schwartzberg HA. Response of confluent and reticulate papillomatosis of Gougerot and Carteaud to topical tretinoin. *Cutis* 2000; 66(4):291-293.
194. Burris K, Kim K. Tattoo removal. *Clin Dermatol* 2007; 25(4): 388-392.
195. Prinz BM, Vavricka SR, Graf P, et al. Efficacy of laser treatment of tattoos using lasers emitting wavelengths of 532 nm, 755 nm and 1064 nm. *Br J Dermatol* 2004; 150(2):245-251.



## Introduction to practical, aesthetic, and social approaches to appearance restoration

Victoria L. Rayner Alatorre

### INTRODUCTION

No one is completely satisfied with the way they look all the time, but for those who are trying to cope with abrupt changes to their image and are experiencing disturbance issues, appearance dissatisfaction is a whole different matter. Every person who has experienced an altered appearance as a result of a disfiguring circumstance has a compelling story to tell. Disfigured persons are constantly being challenged with the awkwardness associated with public exposure and being asked about the origins of their scarring. In such situations, they are not only forced to repeat their story, but as a result, many find that they emotionally relive all the vivid and excruciating details associated with the ordeal of their physical trauma. The need for social interchange and comingling among humans is basic and strong. But so too is the need for privacy, for preserving one's territory—both personal and physical—from the intrusion of strangers (1).

This chapter explores appearance restoration and social skills training in clinical settings as a form of self-directed rehabilitation that helps counterbalance the affects of physical traumatization. The practical information included in this text is intended as an introduction only to appearance restoration and image communication. It is meant to enrich the knowledge of the reader about the scope of the work, its precision and, its implication as well as; answer questions on the topic in terms of its clinical compatibility to dermatology, oncology and cosmetic/reconstructive surgery. The information that follows should only be considered a learning tool that provides an initial understanding into the work experience.

### THE RIGHT TO APPEAR HUMAN

The enormity of living with, and being seen with, a disfigurement day in and day out is beyond the comprehension of those of us who have never experienced similar circumstances. Looking physically different is tough to combat and it is not a challenge that can be solved easily with effortlessness. Simon Weston, the lead Ambassador for the Healing Foundation, a charity in the United Kingdom that raises money for research to help patients deal with the affects of disfigurement, endured years of reconstructive surgery to partially normalize his appearance after a war related injury. It is his contention as a burn injury survivor that the psychological scars related to his image disturbance were just as challenging and emotionally disruptive to his life as the physical discomfort he had to face as a consequence of his physical healing. Persons who suffer from a marred appearance as a result of disfiguring diseases, industrial explosions, house fires, car accidents, and physical attacks or more notably, injuries caused by explosions, clearly, require special aesthetic care. Lack of education in practical aesthetic

approaches that offer the promise of hope and encouragement to such patients limits the resources available to professionals who are charged with the responsibility of informing their patients that their visible scarring is of a permanent nature.

### INTERVENING CARE

Aesthetic operations offered in clinical environments should be interpreted as an additional medical modality under circumstances when the treatment approaches for such patient populations exceeds the medical resources available. In this vein, image improvement measures should be considered an additional form of clinical intervention for masking many variations of disfigurement. When a patient with image issues related to a disfigurement has undergone aesthetic healing measures feels an enhanced sense of self improvement and self-sufficiency, it is clear to all including health care professionals, that progress has been made. Medical care is not complete until the patient has had an opportunity to learn how to work with, and live with, the disfigurement. A therapeutic appearance restoration program focuses on all aspects of the patient's appearance. Which may include and may not be limited to: hair removal and replacement solutions, micropigmentation (skin tattooing), cosmetic rehabilitation (camouflage makeup applications) (Fig. 38.1), skin care, and image development through camouflage dressing.

### PHILOSOPHY OF APPEARANCE RESTORATION

Appearance restoration has evolved from another form of aesthetic intervention, camouflage therapy (the Disfigurement Guidance Center, U.K.). Unlike camouflage therapy, appearance restoration is an advanced level of aesthetic specialization that further addresses the complexities involved in restructuring a gravely disfigured physical identity. Like camouflage therapy, appearance restoration is becoming more widely accepted as a form of aesthetic self-healing and self-directed rehabilitation. It specifically supports the self-sufficiency of disfigured patient populations. It is gradually acquiring its own recognition as a healing modality from: general practitioners, supportive oncologists, cosmetic/reconstructive dermatologists and dermatological surgeons, as well as, an entire spectrum of allied caregivers. In his book, *Visibly Different: Coping with Disfigurement* (August 1997), Associate Professor Richard Lansdown describes a range of approaches which can enhance patient care and support that can be offered by multiple health care disciplines: from researchers to reviewers of service provisions highlighting the importance of innovative applications administered by all members of the professional team.



Figure 38.1 Cosmetic camouflage setup.

Through the practices and procedures of appearance restoration patients are given the capacity to create for themselves, a more secure public persona. They learn how to form an artistic/visual shield that provides them with an aesthetic façade, using a stream of inventive measures that are independent of any realistic view. Patients come to recognize how first exchanges can be strengthened by using a combination of image communication symbols relayed through a series of applied imaginative applications, supported by the use of line, design, texture, shape, form, and color. One or, many of these artistic measures function as distracting elements, serving as visual aids and, acting as strong deterrents to observers by diminishing the initial “*shock factor*” associated with a disfigurement. Some of the greatest challenges patients find themselves facing when they go out in public are related to unwanted attention: excessive staring, distancing from strangers or inappropriate remarks made by people in passing (2).

Facial disfigurement has an effect on the proxemic behavior of the general public as evidenced in a study published in the *Journal of Applied Social Psychology* (3). The personal space afforded to a disfigured or nondisfigured confederate by 450 pedestrians in a busy street was measured. In condition 1, the confederate had a birthmark under the right eye (permanent disfigurement). In condition 2, this was replaced by trauma scarring and bruising (temporary disfigurement). In the third condition, the confederate was “normal” (i.e., no disfigurement). It was found that subjects stood further away from the confederate in the disfigured conditions than in the no disfigurement condition. More specifically, pedestrians arriving first in each trial stood an average distance of 100 cm from the confederate in the birthmark condition, 78 cm in the trauma condition, and 56 cm when the confederate was not disfigured. In addition, subjects choose significantly more often to stand to the left (nondisfigured) side of the confederate with the birthmark and trauma conditions than they did in with the normal condition. Those subjects who chose to stand on the right (disfigured) side of the confederate stood further away from those subjects standing on the nondisfigured side. The implications of the results are discussed in terms of the possible psychological problems associated with facial disfigurement.

### COUNTER MEASURES INTENDED TO COUNTERACT

Appearance restoration opens a whole new window of opportunity for those who are disfigured. Patients are taught to pay close attention to light perspective, color formats and relationships between shape and proportion, patterns and textural differences in apparel fabrics and to always be aware of interesting fashion style combinations that attract their eye. The concentrated assembly of these aesthetic variables is twofold. They may be intended to seize and refocus visual consideration to a specific area, while in another instance; they might be employed to use the patient’s entire presentation as a concealment tactic to draw away attention and help to create multiple diversions.

### SYMBOLISM, MIRRORING TACTICS, AND SOCIAL RECOGNITION

In addition, appearance restoration concepts are to be considered vehicles for the expression of image communication. Patients with abnormalities explore and grow to appreciate the vast reaching power of artistic elements when applied as symbols for their own social rewards. The symbolism inherent in apparel and accessories creates a social platform with which a series of nonverbal messages add to the development of the overall visual composite helping patients relate easier to others because their presentation is one that mirrors culture style thinking, encouraging bonding through familiarity and social recognition.

The theory of art as form has its roots in the philosophy of Immanuel Kant, and was developed in the early twentieth century by Roger Fry and Clive Bell. Art as *mimesis* or representation has deep roots in the philosophy of Aristotle. More recently, thinkers influenced by Martin Heidegger have interpreted art as the means by which a community develops for itself a medium for self-expression and interpretation.

### SOCIAL SUPPORT AND COMPETENCE

For patients with disfigurement, the opportunity to learn social skills is as much, if not, more important, than the ability to restore their aesthetic appearance. A person with image issues

needs to be able to feel confident that they can navigate a variety of social situations. Patients just naturally grasp the significance of being in control of their environments as much as possible. The “wow factor” refers to one of the charismatic strategies that patients can use to captivate others and gain their instant approval (4). Using various aspects of the wow factor and other measures to influence social situations, patients discover that they can be more appealing thus contributing to their readjustment process immeasurably. Through both image development orientation and the comprehension of communication skills, patients are able to strike a balance between being in a public environment and actually being “the” environment. Helen Smith, Director of children’s services at Changing Faces, a leading charity in the United Kingdom that supports and represents people who have disfigurements to the face and hand or body from any cause. Ms. Smith is one of a team of twenty-five psychologists, educators, employers, health care and social workers, media and people who campaign for them. Smith acknowledges the need for patients with disfigurements to have a plan for managing the reactions of others. She recommends that the best way for patients to handle other people’s reactions is to reassure those whom they come in contact with and to try to distract them with their outer confidence. A booklet entitled *Handling Other People’s Reactions*, authored by clinical psychologist, Alex Clarke is made available to individuals with image issues who must struggle with the everyday process of being exposed to the public and who find this the most disturbing dynamic of looking different (5). The first half of this publication covers communication and how human interaction is affected. The second, portion of the booklet contains practical suggestions for enhancing verbal and nonverbal communication together with some exercises to help put the learned skills into practice.

### APPEARANCE RESTORATION HELPS PATIENTS FIND THEMSELVES

Appearance restoration involves a combination of outcome-based private sessions, teaching demonstrations, self-directed patient home study activities, and online learning systems (OLS) to introduce confidence skill building ideas targeted at the special needs of individuals living with disfigurements. With the expert guidance provided by the appearance restoration specialist, patients are capable of establishing reasonable, concrete goals for themselves that help them create new mental pictures, in turn this imaging permits them to think of themselves as vibrant and whole individuals. In certain instances, virtual imagery guided interventions are implemented to digitally help patients envision themselves with a more normalized appearance. Research is currently being conducted at the Virtual Human Interaction Lab at Stanford University, where social scientists are seriously investigating virtual depictions of identity and how they impact human interactions. Positive changes in subject response assessments are indicating a higher incidence of confidence after subjects have participated in the virtual world experiments. More self-assurance is apparent in their social behaviors which are evidenced in the voice inflections, facial expressions, body language and gesturing of test subjects (6).

### GOAL DIRECTEDNESS

The opportunity for physical change and the normalization of abnormalities brings with it the hope of influencing patterns of

thinking, feeling and behaving which is likely to raise brain chemistry releasing chemicals such as dopamine promoting feelings of pleasure and oxytocin associated with supporting feelings of trust. Setting objectives elevates a person’s mood by increasing the likelihood of their success. A 2006 study conducted by Jennifer S. Cheavens, PhD, an assistant professor at Ohio State, cited that persons who set goals for their attainment felt better about themselves, and found more meaning in their lives than those who free-floated to accomplish similar targeted outcomes.

### FOSTERING INDEPENDENCE

More than anything patients want help so they can get through the difficulties associated with their altered images on their own. Step-by-step training prepares patients to identify both the challenges and possibilities of restoring their image to near normality. Patients who participate are eager to try out new ideas and perspectives, although, most have no wish to give up their identity; what they are hoping for is to use the knowledge they acquire to give them better social skills and a sense of continuity to their visual presentation (Fig. 38.2). While appearance restoration therapists may be exuberant about the benefits of the work, they quickly learn to defer to their patients when it comes to the recognized value of the sessions.



Figure 38.2 Shopping excursion with patient.

## STYLE SETS THE STAGE CREATING ITS OWN BACKDROP

Patients identify certain environmental nuances to promote interpersonal communication that they can purposely capture and discreetly reflect back to the social receiver through a cleverly assembled arrangement of artistic elements that are in sympathy with the prevailing atmospheric feeling, tone and color of their immediate surroundings. Mimicking this total effect creates visual synchronization which reduces the unsightly intrusion of their physical abnormality by using a strategy that relies on continuity so that their overall presentation blends in. A harmonious technique such as this one screens out the alarming appearance of a disfigurement, which in effect, is still very much present but, hidden in plain sight. When this concept is combined with the appropriate social skills, the patient's image becomes an indirect expression of cooperative intent and thereby, the message they send promotes liking and it fosters an intervening sense of familiarity as well. It has the potential from one social counterpart to another to activate trust, respectively, by insisting that the receiver and the sender are closely tied to each other by the same common perspective.

## OVERVIEW OF APPEARANCE RESTORATION SESSIONS

One of the most effective coping mechanisms available to persons with disfigurement is appearance restoration. The image transformation sessions are a means for patients to achieve a hoped-for result. Patients are taught to pay close attention to light perspective, color formats and relationships between shape and proportion, patterns and textural differences in fabrics and line quality and to always be aware of interesting fashion style combinations that attract their eye. The concentrated assembly of these aesthetic variables may be intended to seize focused consideration to one area, while in another instance; the patient's entire presentation becomes a concealment tactic to draw away attention and help to create multiple diversions.

## PREPARATION AND IMPLEMENTATION

The series of four consultations begin with a patient questionnaire to offset initial tension and to give the patient a sense of order and control over the session. The work is intended to inspire a broader meaning beyond just the manifestation of a restored appearance. The idea is to give visible form to a more inner dimensional part of the patient that cannot be as readily seen—his or her spirit. Patients who participate in appearance restoration use the information they are given as the foundation for their new identity and as a way to experiment and test their artistic ability until the manner in which they present themselves feels instinctually right. The idea is to engage patients in a light and exuberant field of play that inspires the release of subconscious imagery leading to revelations about their innate sense of style that they never would have thought of on their own. Appearance restoration specialists point patients in an entirely new direction instead of just giving them a few instructions they thought they needed. This form of transformation takes longer and requires more focus than image consulting because participants must become aware of their inner processes. It requires that patients spend time on themselves evaluating all the individual parts of their physical

presentation, analyzing and learning the process of making decisions about how they want to be interpreted (both aesthetically and socially) so that they ultimately orchestrate the transformation completely. The home study and the online component help to guide them so they can reflect on what they want to change. The ideas, information and insights they acquire open up the possibilities for personal experience, different ways of seeing themselves and increased confidence. By exploring the notion of appearance restoration patients come to discover in significant terms that which helps them to define themselves using both style imagery and social skills so they can sculpt their new identity journeying deep into their new formation of self. The role of the appearance restoration specialist is one of impartiality. They are translators and clarifiers and are on hand to interpret and summarize and help with their patients understanding but not to dictate or judge.

## PIECING TOGETHER MAJOR ELEMENTS OF THE IMAGE PUZZLE

A good presentation is the result of a conscious and a creative partnering effort on the part of both the provider and the patient. Appearance restoration requires a basic understanding of the first impression factors that impact presence such as; the timeliness of clothing trends, good lines, good fit, originality, proper accessories, and matching suitable attire to the occasion. Patients who seek to restore their appearance can do so by tapping into a camouflage dressing system that not only conceals their physical irregularities but defines their sense of individual style. Learning does not stop when the sessions conclude; patients are required to complete a series of follow-up home assignments. These special image building, self-directed training exercises help them to become even more aware of the influence on others of their selection of colors, fabric textures, patterns and style designs that specifically will appeal to those who will be viewing them.

## THE PROCESS OF APPEARANCE RESTORATION IDENTIFIED

Appearance restoration is an invitation for patients to develop their own *effective* presentation styles. For appearance restoration therapy to be successful the patient must be willing and able to investigate several options to meet his or her own unique requirements. Self-motivation is mandatory given that a set of disciplines are involved such as; participation in the distance education component for the attainment of heightened social skills, confidence building and tenacity to complete each of the home assignments. This is the reason why no patient should ever be coerced into taking part in the sessions. Prospective candidates are those that express a sincere interest and enthusiasm in reestablishing their physical identity through this very strategically organized, expertly guided, self-learning process (Fig. 38.3).

## THE INTERVIEWING PROCESS

If the patient's disfigurement is associated with an emotional trauma, a preassessment interview is indicated, to be conducted by a psychiatric physician/nurse, intern, social worker, family practice physician or other members of the medical team trained to understand diagnostic criteria. The psychodynamic life narrative is a psychotherapeutic maneuver used during the



**Figure 38.3** Patient (A) before and (B) after cosmetic result accomplished by the patient with minimal assistance.

first few sessions of a consultation with a patient in a crisis situation. It is recommended when appearance restoration treatments are contemplated for patients who have suffered from experiences related to posttraumatic syndrome disorder (PTSD). In certain instances it may lead to significant change, particularly in the area of self and object representations (7).

### DESCRIPTION AND SEQUENCE OF THE THERAPEUTIC PLAN

Appearance restoration is a series of four sessions as follows:

#### Session One

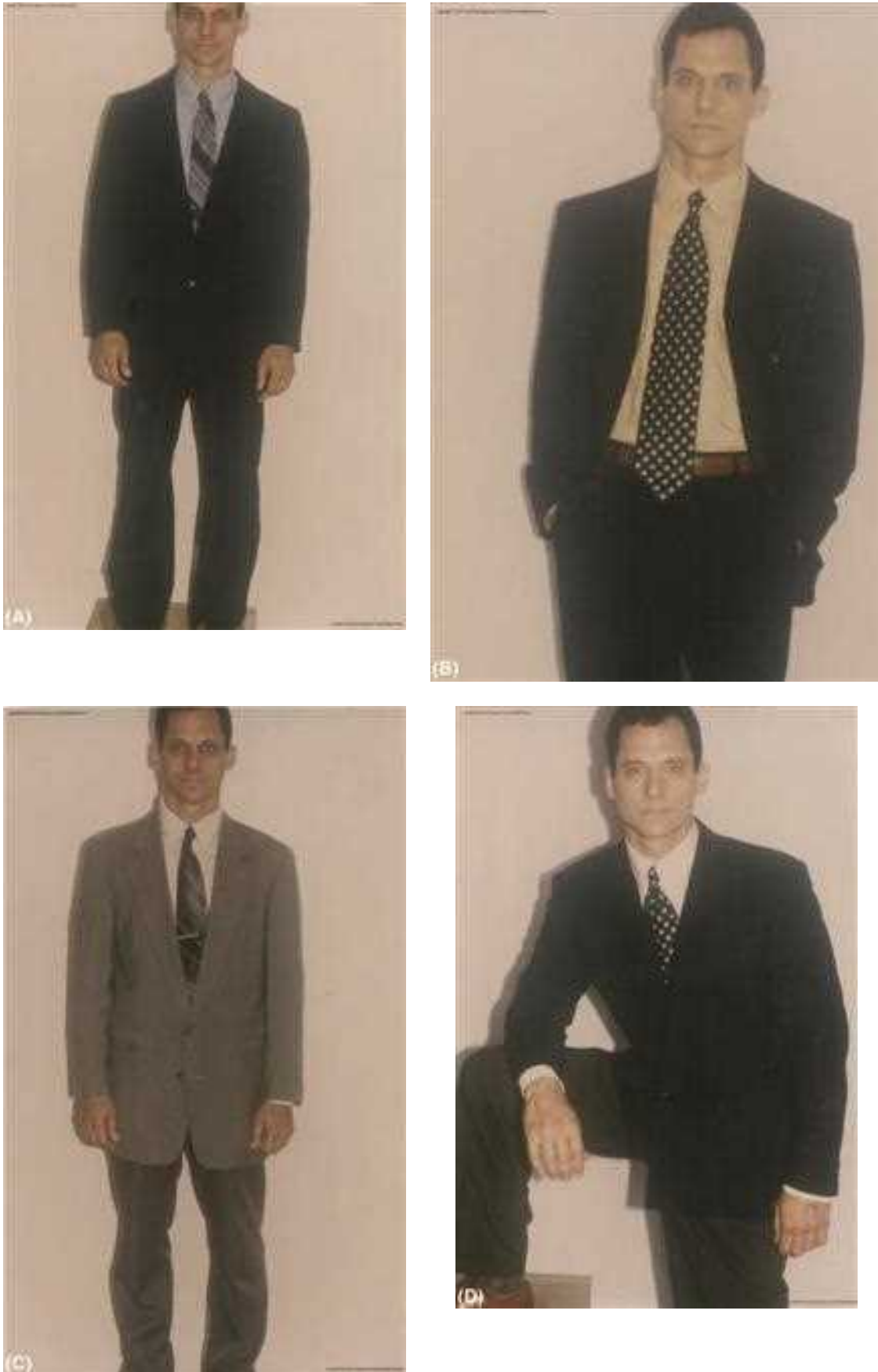
Involves the initial consultation. It entails a private meeting with the aesthetic provider and the patient. It is the time when patients fill out their questionnaires. The patient's answers piece together a comprehensive profile that reveals major elements that make up the patient's self-perceptions regarding their feelings of self-worth, perceived level of social acceptance, inherent and acquired artistic abilities and the patient's measurement depicting the gap between their ideal presentation and the reality of their present persona (Fig. 38.4). Other inquiries involve the patient's ability to define their preferences for theme dressing (by identifying celebrities whose appearances they might consider emulating) from four groupings of stereotype themes. For women these include (Fig. 38.5): feminine/romantic; classic/elegant; casual/sporty; or dramatic/exotic. There are eight preferences of male stereotype classification models: distinguished (Fig. 38.6); hunky; athletic/sporty;

down-home male; cowboy; trendy/artistic male; the collegian male; and the romantic/nostalgic man; or a fusion of two distinct styles—sporty/distinguished. The recorded answers also identify intentions and patients expectations for upcoming sessions. It is during this appointment that patients are given a full explanation of the next three sessions. At the conclusion of these appointments, providers analyze their patient's questionnaires and with the data supplied customize their therapeutic plans.

If the patient seeks cosmetic rehabilitation and chooses to learn how to conceal skin irregularities with the use of special, occlusive and waterproof cosmetic agents or with mineral powder solutions, the questionnaire can be sent prior to his or her appointment (Fig. 38.7). The treatment provider can review the document upon its return, making the appropriate notations and arrangements for a formal telephone interview and the consultation can be conducted prior to the substituted session.

#### Session Two

Involves a review of the recommendations made by the provider and a color analysis with an emphasis on the persuasive power of color. Patients learn how color can be used to communicate nonverbal messages on their behalf. Patients are color draped to identify their own individual seasonal color palate with color systems such as the ones described in the publication *Color Me Beautiful* by C. Jackson (1980) and are given a home assignment to select color schemes that are in concert with their



**Figure 38.4** Patient (A) before and (B) after minimal assistance; (C) and (D) show further before and after views.



**Figure 38.5** Patient (A) before and (B, C) after cosmetic result accomplished by the patient with minimal assistance. (D) and (E) show a second patient before and after similar assistance.



Figure 38.5 Continued



Figure 38.6 (A) The distinguished type. (B) The trendy type. (C) The romantic/nostalgic type. (D) A mixed type—sporty/distinguished.





Figure 38.6 Continued



Figure 38.7 The patient participates in selecting shade(s) from a color palette.

natural coloring (shades that are the most complimentary to their hair, eyes and skin tone) lending support to their overall image. These two color approaches help to normalize the appearance of patients and deflect attention away from scarring with the use of strong color visual combinations to add depth to their appearance making their images more interesting (Fig. 38.8). Educational handouts are provided to patients to explain every aspect of the color information covered in the session, color swatches are also given out along with any other aids that providers deem necessary for the completion of the patient's home assignment.

### Session Three

Involves clothing selection and personal image coaching. During this phase of appearance restoration, the patient becomes familiar with the various style prototypes and wardrobe planning. As patients awareness of which clothing items and accessories fall into standard style modes and what these classifications convey to others in terms of cultural symbolism, they begin to recognize how customizing their preferred style type can become the basis for camouflage costuming; and their new identities begin to emerge. To work through this process they must first create a wardrobe manual in which they chose and insert illustrations that verify their comprehension of the concepts learned by selecting outfits for leisure day wear, career wear evening wear and a broad spectrum of other activities. When patients return for their fourth session they



**Figure 38.8** Color draping. Patient (A) before and (B) after.

are asked to bring with them photographs of three ensemble examples using items taken from their own wardrobe as a means for proving comprehension of the knowledge acquired.

#### Session Four

The fourth and final session focuses around new directions in image development and identity. It also includes care and treatment of the skin, personalized instruction and overall body and mind wellness maintenance essentials. The sessions begin with a complete review along with recommendations regarding the patient's wardrobe, hair and accessory selections from the assigned homework given at the prior session. Patients are asked to give a brief verbal summary of their

experience to ensure that they understand the silent messages conveyed by their style choices of costuming. All sessions include confident building components that contribute to a patient's sense of self-assurance in what gradually evolves into becoming a self-directed appearance restoration process.

#### APPEARANCE RESTORATION AS A HEALING MODALITY

To be truly beautiful is to be healthy as a whole in one's mind, one's body and in one's spirit. It is to be sensitive to the aesthetic experience and to allow oneself to be thoroughly moved by it. Appearance restoration extends well beyond oneself and into the far reaches of the consciousness of others. When the aesthetic component is conceived in this context it becomes a cohesive force that permeates the mindsets of both senders and receivers. It establishes a forum for more common interests and compassionate unions between strangers that emerge. Appearance restoration has no meaning unless the impact it creates has meaning. It is in this context that aesthetic applications in clinical environments adapt a healing focus it is when beauty becomes more than a mere tool for one's vanity that aesthetic caregiving is present. Once better understood, the image modifications described here and the learned support skills can form bridges that breakdown biases effecting behaviors and outlooks for those who must live with the effects of disfigurements and disabilities on a daily basis.

#### REFERENCES

1. Macgregor, Cooke, Frances. *Aesthet Plast Surg* 1990; 14:249-257.
2. Living with a disfigurement—managing the challenge. The way you face disfigurement. *Changing Faces*. 2004.
3. *Journal of Applied Social Psychology* 2006; 12(2):137-150.
4. Humans perceive more than they think they do. University of California, Riverside, April 14, 2006.
5. *Changing Faces*. 2007.
6. Bailenson, Jeremy. *PBS Frontline Digital Nation*. Social behavior, virtual, reality. February 2010.
7. Viederman M. *Psychiatry* 1983; 46(3):236-246.

#### BIBLIOGRAPHY

- Rayner LV. *Dermatologist Affiliate, Clinical Cosmetology a Medical Approach to Esthetic*. Delmar Publishing, 1993.
- Advances in skin and wound care. *J Prev Healing* 2009; 22(1):9-44.
- Rayner LV. *Camouflage Therapy Conquering Children's Emotion*. Skin, Inc., 1996:94-97.
- Camouflage therapy. *Dermatol Clin* 1995; 13(2):467-472.
- Rayner LR. Expanding the boundary: appearance counseling beyond facial treatments. *Les Nouvelles Esthetiques* 1996. 21-23.
- Assessing camouflage therapy for the disfigured patient: a personal perspective. *Dermatol Nurs* 2000; 2:101-103.
- Antoniou C, Stefanaki C. *Cosmetic camouflage*, Dermatology Department, University of Athens Medical School, Andreas Sygros Hospital, Athens, Greece 2006 Blackwell Publishing. *J Cosmet Dermatol* 2006; 5:297-301.
- Vodvarka F. *Aspects of color white paper*. Loyola, University of Chicago, 1999. Available at: [http://www.midwest-facilitators.net/downloads/mfn\\_19991025\\_frank\\_vodvarka.pdf](http://www.midwest-facilitators.net/downloads/mfn_19991025_frank_vodvarka.pdf).
- Mood-lites white paper 5/21/2001. Available at: [http://www.moodfactory.com/press/Colors\\_and\\_Moods\\_White\\_Paper.pdf](http://www.moodfactory.com/press/Colors_and_Moods_White_Paper.pdf).
- Rehabilitation Council of India New Delhi. *White paper in clinical psychology*. Available at: [http://rehabcouncil.nic.in/programmes/ano/M.PHIL\\_Clesy.pdf](http://rehabcouncil.nic.in/programmes/ano/M.PHIL_Clesy.pdf).
- Blakeney PE, Rosenberg M, Rosenberg L, et al. *Documents pdf*. Available at: <http://www.worldburn.org/documents/PsychosocialCare.pdf>.

- Revelli C. *Color and You: A Guide to Discovering Your Best Colors*. Revelli, 1982.
- Revelli C. *Style & You: Every Woman's Guide to Total Style*. Revelli, 1993.
- Richmond J. *Reinvent Yourself with Color Me Beautiful: Four Seasons of Color, Makeup, and Style*. Taylor Trade Publishing, 2008.
- Cynthia L. Rapid prototyping in the textile & apparel industry: a pilot project (abstr). *J Textile Apparel Technol Manage* 2000; 1(1).
- Jackson C. *Color Me Beautiful: Discover Your Natural Beauty through the Colors That Make You Look Great and Fabulous*. Random House Publishing Group, 1980.
- Richard HP, Avrum S. *Philosophy Made Simple*. 2nd ed. (revised). Broadway Book, 1993.
- Rumsey N, Clarke A, White P, et al. Altered body image: appearance-related concerns of people with visible disfigurement. *J Adv Nurs* 1976; 48(5):443-453.
- Rumsey DH. *Body Image and Disfigurement: Issues and Interventions 1*. Elsevier B.V., 2004, 83-87.
- Newell R. *Body Image Disfigurement*. Routledge, 2002.
- Neil SS. The impact of cosmetic interventions on quality of life dermatology. *Dermatol Online J* 2008; 14(8):2. Available at: <http://dermatology.cdlib.org/148/commentary/qualityoflife/sadick.html>.

## Treatment of keloids

Joshua E. Lane, Tanda N. Lane, and John L. Ratz

### INTRODUCTION

Keloids and hypertrophic scars represent abnormal wound responses. These occur most commonly in predisposed individuals. The formation of keloids and hypertrophic scars typically occurs following some form of trauma, whether intentional or not. This may include surgery, burns, trauma, inflammation, or infection. However, some keloids do form spontaneously, without any apparent predisposing trauma. Keloids are characterized by scar tissue that extends beyond the original dimensions of a wound, while hypertrophic scars maintain size within the predictable dimensions of the original wound.

As such, keloids should be differentiated from normal and hypertrophic scars that are confined to the original dimensions of a wound. A normal scar heals within the confines of the inciting injury. Hypertrophic scars increase in size as an outward growth, while keloids are capable of both inward and outward extension.

Both keloids and hypertrophic scars present a clinical challenge in prevention and treatment. Multiple methods of treatment have been reported; however, none of these have proven optimal.

### HYPERTROPHIC SCARS VS. KELOIDS

Keloids and hypertrophic scars can occur in individuals of all ages and race; however, they are more common with darker pigmented skin types. They represent examples of exuberant scarring. The incidence of keloids has been reported to be as high as 16% in black individuals. Keloids tend to be less prevalent in the young and the elderly. The highest incidence was reported to range from ages 10 to 30 years. Other reports suggest the average age of patients with keloids at the time of initial treatment to be about 26 years.

Recommendations for ear piercing to avoid keloid formation have been made based on these trends. In one study, individuals formed fewer keloids following ear piercing if performed before the age of 11. Genetic inheritance patterns have also been reported.

Keloids tend to demonstrate a predilection for certain anatomic regions including the presternal area, chest, back, shoulder, anterior and posterior neck, and earlobes. Many summarize this predilection as the "cape area." In addition, keloids continue to evolve while hypertrophic scars typically subside. Just as there are clinical differences between keloids and hypertrophic scars, so too are there characteristic histologic differences that separate the two entities.

### ETIOLOGY

A genetic predisposition combined with some form of external injury may lead to the formation of keloids and/or hypertrophic scarring in certain individuals. Injury to the skin may occur in a variety of intentional or unintentional means. Spontaneous

keloids develop without a clear-cut history of trauma and favor the chest, upper back, shoulders, and arms (Figs. 39.1 and 39.2).

Another important aspect of keloid and hypertrophic scar formation is that of wound tension, which has been implicated as an instigating factor. Surgical incisions should be performed to minimize these forces of tension whenever possible. Additionally, the use of dermal sutures placed appropriately can assist in the reduction of wound tension and, in this way, help minimize the chances of keloid formation.

Thus, a combination of factors including the nature of injury, severity, depth, anatomic location, tensional stress, infection, environmental factors, and genetic predisposition all contribute to the potential for and severity of hypertrophic scar and/or keloid formation. Evidence of a genetic predisposition for keloid formation is demonstrated by its increased frequency in different ethnic populations, a family history of keloid formation, and its occurrence in twins.

### CLINICAL EXAMINATION

An understanding of both hypertrophic scars and keloids is essential for accurate diagnosis of keloids. Clinical examination can typically differentiate between these two entities. Hypertrophic scars are confined to the traumatized region, while keloids extend beyond the initial confines of trauma (Fig. 39.2). This is the primary visual means of differentiating hypertrophic scars and keloids. In areas where stretch-back scarring can be predicted, hypertrophic scar formation is often mistaken for keloid formation because of the increased width of the scar. Occasionally, removal of a keloid results in a hypertrophic scar that, again, is often confused with a recurrence of the keloid.

Hypertrophic scars typically develop quickly after an inciting surgery and subside gradually over time. In contrast, keloids often develop more slowly and do not resolve (Fig. 39.3). Hypertrophic scars may be treated with surgical revision, while this may result in additional keloid formation and/or worsening of the treated keloid.

The size of a hypertrophic scar is usually reflective of the inciting injury; however, a small injury can yield a large keloid (Figs. 39.4–39.8). Keloids in areas such as the neck and chest can grow to massive size and cause restriction of movement (Fig. 39.1). Treatment of keloids of this size and body restriction proves especially difficult.

### HISTOLOGY

Histologic examination of a keloid (and hypertrophic scars) demonstrates a random array of thick, hyalinized, eosinophilic collagen bundle deposition (Fig. 39.9). This is in contrast to that of the normal skin, in which the collagen bundles are seen in parallel to the skin surface. Differentiation between hypertrophic scars and keloids is also possible. The collagen bundles



**Figure 39.1** Keloids on the chest with restriction of movement due to extensive involvement. These are spontaneous keloids and occurred without any known trauma.



**Figure 39.2** Spontaneous keloids on the chest wall. No known surgical or trauma occurred to form these keloids.

seen in hypertrophic scars are flatter and less demarcated than those in the normal skin. Collagen fibers are seen in a wavy pattern. These features are more pronounced in keloids. Occlusion of microvessels is reported to occur in both hypertrophic scars and keloids. Differentiation is typically possible via clinical examination.

### **PATHOGENESIS**

The pathogenesis of keloid formation still remains largely unknown. Recent advances have implicated the role of transforming growth factor- $\beta$  (TGF- $\beta$ ) and platelet-derived growth

factor (PDGF). These play a role in modulating contractile forces in skin fibroblasts. A brief overview of wound healing assists in the discussion of pathogenesis.

There are three primary phases of normal wound healing: inflammatory, proliferative/fibroblastic, and maturation/remodeling. The inflammatory phase consists of an immediate influx of inflammatory mediators into the site involved. A fibrin clot is initiated during this phase. This occurs by capillary dilation and subsequent delivery of these mediators. The fibroblastic phase consists of fibroblast advancement into the fibrin clot with production of new collagen. The maturation phase occurs as the wound matures via collagen synthesis and

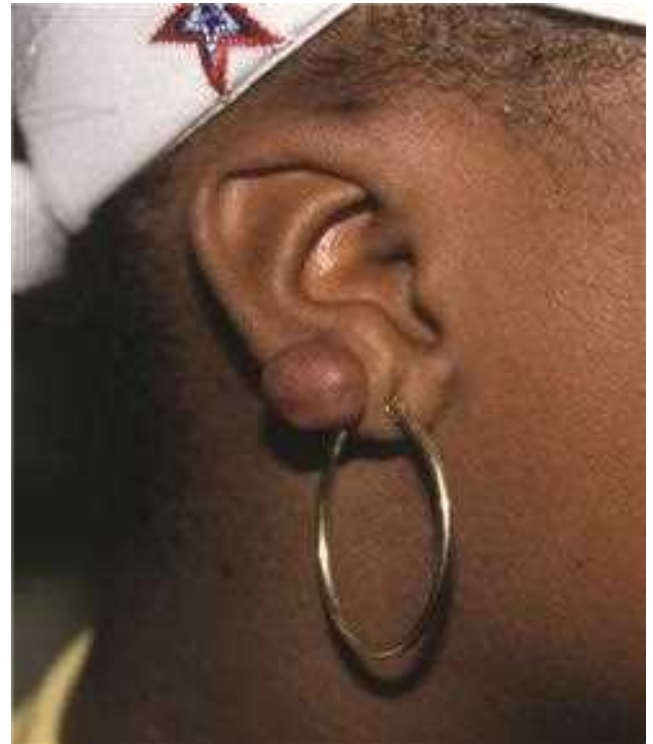


**Figure 39.3** Hypertrophic scar (A) following a surgical procedure and keloid (B) resulting from trauma to the left arm.

degradation. A variety of signaling molecules [TGF- $\beta$ , PDGF, matrix metalloproteinases (MMPs), tissue inhibitors of metalloproteinases (TIMPs)] regulate this process.

With this basic template of the wound healing process in place, the faults by which keloids and hypertrophic scars occur can be demonstrated. Early forms of fibroblasts have been shown to persist longer in keloids than in the normal skin. This persistence of early fibroblasts likely results in increased collagen production. This collagen synthesis is 20 times greater in keloids than in the normal skin. While the dominant type of collagen in the normal skin is type I, keloids have both types I and III.

Growth factors have showed the most promise in the quest for keloid pathogenesis. TGF- $\beta$  promotes fibroblasts to localize to sites of inflammation to begin extracellular matrix protein synthesis. While this activity is normally turned off when repair is complete, dysregulation of TGF- $\beta$  activity is likely a key factor in keloid production. Decreased synthesis of molecules that promote collagen matrix breakdown (MMPs) has also been shown to be a factor in keloid pathogenesis. Other studies have shown that infrared light can inhibit fibroblast proliferation and activity. How this happens is unknown, but it may be why some success has been reported with carbon dioxide (CO<sub>2</sub>) laser (an infrared laser) excision of keloids.



**Figure 39.4** Keloid formation secondary to piercing of the ear in an adolescent. Piercing was performed at the age of 13.



**Figure 39.5** Keloid on the posterior ear secondary to piercing of the ear.



**Figure 39.6** Keloid on the right earlobe secondary to piercing of the ear in adolescence.

## TREATMENT

Treatment of keloids and hypertrophic scars presents a clinical challenge. As the two entities are similar, treatment of such is also similar. The fact that traumatic injury is the typical cause

highlights the difficulty of any type of surgical treatment. Treatment options include a multitude of possibilities ranging from noninvasive to invasive. The choice of treatment depends on a variety of factors, including the patient (age, health), location, size, depth, and previous treatments.

A number of topical treatment modalities have been successfully used to treat keloids and hypertrophic scars (Table 39.1). A common technique used at the initial time of diagnosis is gentle massage of the site. Instructions to the patient include a gentle rocking massage for several minutes to be performed several times per day. This can be useful for smaller scars and especially in sites where web formation is a possibility. The use of special “keloid medications” has not been shown to be better than just massage alone.

The use of mechanical pressure is used as both treatment and prophylaxis. This is commonly seen with pressure earrings used to both treat and prevent keloids secondary to ear piercing. Treatment with mechanical pressure takes time and may require as long as 6 to 12 months or longer for acceptable results. Additionally, use of pressure garments should be 23 to 24 hr/day. Success in treatment thus is largely dependent on patient compliance.

Silicone gel sheeting is believed to act by scar hydration, resulting in decreased capillary flow with subsequent reduction in collagen deposition from a decrease in circulating proinflammatory cytokines. Some authors have demonstrated excellent success rates with silicone gel sheeting, while others attribute its success to the occlusive wound effects. Silicone sheeting should be worn for a minimum of 12 hr/day and for a minimum of 2 months. The true “gel” types of sheeting have been shown to give more consistent results than the dry “card-like” sheeting.

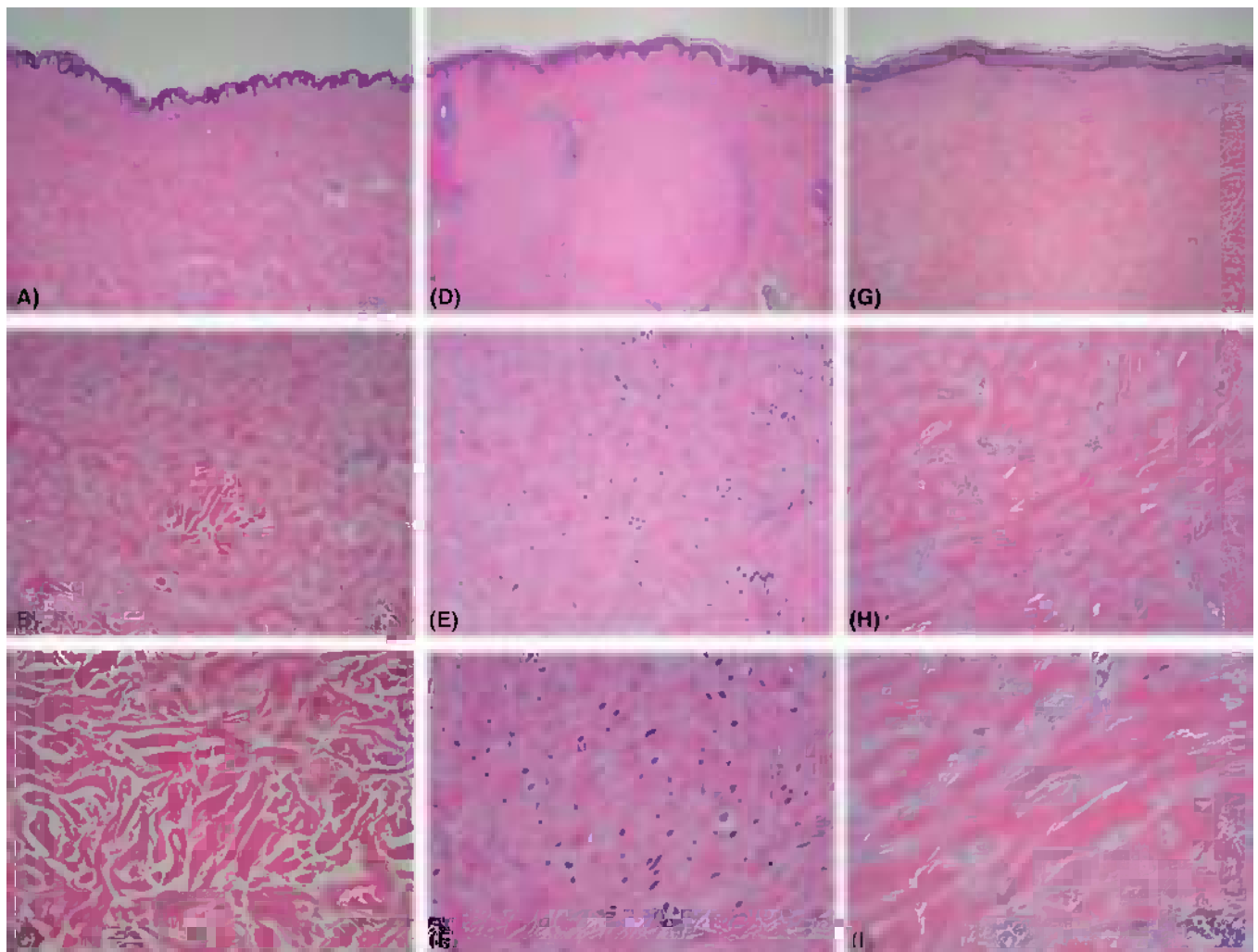
The use of cryosurgery in the treatment of keloids and hypertrophic scars is much like that in the treatment of other dermatologic conditions. Cryosurgery utilizes a cryogenic



**Figure 39.7** Large pedunculated keloid on the right earlobe. Patient had piercing performed in adolescence.



**Figure 39.8** Excision of keloid on right earlobe with transmural excision (dumbbell technique).



**Figure 39.9** Histopathology of normal skin (A–C), hypertrophic scars (D–F), and keloids (G–I). These are shown at 4× magnification (*top row*), 10× magnification (*middle row*), and 20× magnification (*bottom row*). Normal skin has distinct collagen bundles that are predominantly arranged parallel to the epidermal surface. Evaluation of hypertrophic scars demonstrate less order of the collagen bundles, and keloids are marked by haphazard arrangement of collagen fibers with random orientation.



**Table 39.1** Treatment of Keloids and Hypertrophic Scars

Topical
Massage
Pressure
Silicone gel
Cryotherapy
Tacrolimus
Retinoids
Intralesional injection
Corticosteroid (triamcinolone acetonide)
Interferon- $\alpha$ 2b
5-Fluorouracil
Verapamil
Laser
Pulsed dye
Argon laser
Nd:YAG laser
CO <sub>2</sub> laser
Oral
Surgical
Radiation therapy
Other

agent (liquid nitrogen) to induce direct cellular and micro-circulatory damage. This leads to tissue necrosis and hopeful flattening of the lesion. The primary risk of this method is hypopigmentation of the treatment site. Success rates as high as 74% have been claimed with the use of cryosurgery to treat keloids. It has also been noted that younger keloids tend to respond better to cryosurgery than older keloids. It can also be used as an adjunct to initial corticosteroid intralesional injection. The edema that results from cryosurgery loosens the scar-like fibers and facilitates easier injection.

Topical corticosteroids remain a common first-line treatment of both keloids and hypertrophic scars. The known side

effect of skin atrophy is harnessed and used to the clinician's advantage. Similar medications such as tacrolimus and pimecrolimus demonstrate some potential; however, these are weaker than most corticosteroids utilized, and thus may be most efficacious in anatomic locales where stronger corticosteroids are not possible.

Intralesional injection remains the mainstay of treatment of keloids and hypertrophic scars. The most common and perhaps useful medication used is triamcinolone acetonide, a corticosteroid, available as a suspension and not a solution. Triamcinolone acetonide is injected and is available in multiple concentrations—10 and 40 mg/mL are most often used as alternate dilutions that can be prepared easily from these stock concentrations. The dose and concentration varies based on the size and location of keloid; however, this may range from 5 to 40 mg/mL. Injecting a medication into a keloid represents a physical challenge due to the frequent density and firmness of a keloid. A basic understanding of Poiseuille's law is important in the efficacious delivery of medication. This law defines the volume flow rate as the pressure difference divided by the viscous resistance. More succinctly, this law determines the resistance to flow. The important point for the clinician is that a smaller diameter syringe allows more mechanical advantage for injection. A 1 cc tuberculin syringe with a lure lock tip and 27 gauge or larger needle is recommended. Lack of a lure lock system frequently results in the propulsion of the needle from the syringe due to even greater pressure within the keloid. The N-Tralig injector utilizes a ratchet-type mechanism to allow injection of medication into keloids and hypertrophic scars (Figs. 39.10 and 39.11). Another useful technique with keloid injection is the Dermajet (Fig. 39.12). This specialized syringe allows one to inject medication without using a needle.

In all cases, it is important to keep from injecting into subcutaneous fat as the atrophy that follows is difficult to correct. Injection around or near the eye should also be carried

**Figure 39.10** N-Tralig mechanical injector.



**Figure 39.11** Intralesional treatment of a hypertrophic scar with the N-Traig mechanical injector.



**Figure 39.12** Dermajet injector.

out with caution, as particles from the suspension has been shown to cause amaurosis through embolization.

The use of retinoids for the treatment of keloids and hypertrophic scars has been suggested topically; however, they have also been cited as a potential causative agent when taken orally. The risk of scarring is well documented following recent treatment with isotretinoin and acitretin. Decrease in size of

keloids treated with tretinoin 0.05% topically for 12 weeks has been described.

The use of imiquimod 5% cream has been met with mixed reviews in prevention and treatment of keloids. Imiquimod is a topical immune response modifier that stimulates interferon- $\alpha$  (INF- $\alpha$ ). This is a proinflammatory cytokine that increases collagen breakdown. Although there are conflicting

results in the literature, most of these studies consist of small study groups. Given the favorable results in many studies and the overall safety profile of imiquimod, it is a simple and potentially useful adjunctive therapy for treatment of keloids.

Reports of using calcium antagonists to retard extracellular matrix production in connective tissue equivalents and intralesional verapamil to treat keloids have also appeared in the literature.

The use of lasers to treat keloids and hypertrophic scars has been met with some success (Figs. 39.13–39.19). A number of different lasers have been tried but the main two that remain in use are the pulsed dye laser and the CO<sub>2</sub> laser. The pulsed dye laser is a 585 or 595 nm system. Frequency-doubled Nd:

YAG systems have also demonstrated benefit in the treatment of keloids and hypertrophic scars. Pulsed dye lasers have the capability of reducing the size and redness of keloids and hypertrophic scars. They can also normalize the surface texture of keloids and hypertrophic scars. The CO<sub>2</sub> laser is an ablative laser that vaporizes tissue and can be used to excise keloids (Figs. 39.13–39.19). It, being an infrared light source, may act by having an inhibiting effect on fibroblasts.

Surgery is commonly used to treat keloids and hypertrophic scars; however, it must be used with caution as this may result in keloid formation itself, sometimes worse than the initial lesion. The risk of anticipated keloid formation from surgical intervention itself often warrants adjuvant



**Figure 39.13** Treatment of keloids (before) with CO<sub>2</sub> laser (*left*). Multiple treatment sessions were required with resultant improvement and decreased thickness (*right*). Of note, the resultant scars represent hypertrophic scars, an improvement over the previous keloids.



**Figure 39.14** Use of CO<sub>2</sub> laser to ablate large keloid on the pre- and postauricular cheek.



**Figure 39.15** Postoperative result after CO<sub>2</sub> ablation of keloid (from Fig. 39.14) at 2.5 months (A) and 4.5 months (B,C). The resultant surgical scar represents a hypertrophic scar but an improvement over the previous keloid.



**Figure 39.16** Large keloid on right cheek of a young man.



**Figure 39.17** Surgical excision of large keloid.



**Figure 39.18** Use of CO<sub>2</sub> ablation to remove and recontour keloid on right cheek.



**Figure 39.19** Postoperative result after CO<sub>2</sub> ablation of large keloid on the right cheek.

therapy such as postoperative corticosteroid injections. Recurrence of keloids following surgical intervention varies from 50% to 80%.

Radiation therapy may be utilized for reduction of keloid size on account of its ability to destroy fibroblasts and neo-vascular buds via ionizing radiation. Radiation is typically used

in conjunction with surgery as it is minimally effective alone. The risks of ionizing radiation must certainly be weighed against the possible benefits.

A number of less common but reported treatments include the use of onion extract, cultured epithelial autografts, pentoxifylline, colchicine, calcium antagonists, tranilast, and vitamin E.

## BIBLIOGRAPHY

1. Akaishi S, Akimoto M, Ogawa R, et al. The relationship between keloid growth pattern and stretching tension: visual analysis using the finite element method. *Ann Plast Surg* 2008; 60:445–451.
2. Berman B, Harrison-Balestra C, Perez OA, et al. Treatment of keloid scars post-shave excision with imiquimod 5% cream: a prospective, double-blind, placebo-controlled pilot study. *J Drugs Dermatol* 2009; 8:455–458.
3. Border WA, Noble NA. TGF- $\beta$ . *Sci Am Sci Med* 1995; 2:68–77.
4. Bouzari N, Davis SC, Nouri K. Laser treatment of keloids and hypertrophic scars. *Int J Dermatol* 2007; 46:80–88.
5. Bran GM, Goessler UR, Hormann K, et al. Keloids: current concepts of pathogenesis. *Int J Mol Med* 2009; 24:283–293.
6. Brissett AE, Sherris DA. Scar contractures, hypertrophic scars, and keloids. *Facial Plast Surg* 2001; 17:23–272.
7. Brown JJ, Bayat A. Genetic susceptibility to raised dermal scarring. *Br J Dermatol* 2009; 11:8–18.
8. Burk CJ, Aber C, Connelly EA. Ehlers-Danlos syndrome type IV: keloidal plaques of the lower extremities, amniotic band limb deformity, and a new mutation. *J Am Acad Dermatol* 2007; 56: S53–S54.
9. Cação FM, Tanaka V, Messina MC. Failure of imiquimod 5% cream to prevent recurrence of surgically excised trunk keloids. *Dermatol Surg* 2009; 35:629–633.
10. Chrapil M, Peacock E, Carlon ES, et al. Colchicine and wound healing. *J Surg Res* 1980; 28:49–56.
11. Copcu E, Sivrioglu N, Oztan Y. Combination of surgery and intralesional verapamil injection in the treatment of the keloid. *J Burn Care Rehabil* 2004; 25:1–7.
12. Cosman B, Crikelair GF, Ju MC, et al. The surgical treatment of keloids. *Plast Reconstr Surg* 1961; 27:335–345.
13. D'Andrea F, Brongo S, Ferraro G, et al. Prevention and treatment of keloids with intralesional verapamil. *Dermatology* 2002; 204:60–62.
14. Darzi MA, Chowdi NA, Kaul SK. Evaluation of various methods of treating keloids and hypertrophic scars: a 10-year follow-up study. *Br J Plast Surg* 1992; 45:374.
15. Dockery GL, Nilson RZ. Treatment of hypertrophic and keloid scars with Silastic gel sheeting. *J Foot Ankle Surg* 1994; 33:110–119.
16. Edgerton MT, Hahrahan EM, Davis WB. Use of vitamin E in the treatment of keloids. *Plast Reconstr Surg* 1951; 8:224–233.
17. English RS, Shenefelt PD. Keloids and hypertrophic scars. *Dermatol Surg* 1999; 25:631–638.
18. Engrav LH, Gottlieb JR, Millard SP, et al. A comparison of intra-marginal and extramarginal excision of hypertrophic burn scars. *Plast Reconstr Surg* 1988; 81:40–45.
19. Goeminne L. A new probably X-linked inherited syndrome: congenital muscular torticollis, multiple keloids, cryptorchidism and renal dysplasia. *Acta Genet Med Gemellol (Roma)* 1968; 17:439–467.
20. Goodfellow A, Emmerson RW, Calvert HT. Rubinstein-Taybi syndrome and spontaneous keloids. *Clin Exp Dermatol* 1980; 5:369–370.
21. Haas AF, Reilly DA. Cultured epithelial autografts in the treatment of extensive recalcitrant keloids. *Arch Dermatol* 1998; 134:549–552.
22. Hendrix JD Jr., Greer K. Rubinstein-Taybi syndrome with multiple flamboyant keloids. *Cutis* 1996; 57:346–348.
23. Hintz BL. Radiotherapy for keloid treatment. *J Natl Med Assoc* 1973; 5:71–75.
24. Kaminer MS, Arndt KA, Dover JS, et al. *Atlas of Cosmetic Surgery*. 2nd ed. China: Saunders, 2009.

25. Katz BE. Silicone gel sheeting in scar therapy. *Cutis* 1995; 56:65–67.
26. Kim WJH, Levinson H, Gittes GK, et al. Molecular mechanisms in keloid biology. In: Garg HG, Longaker MT, eds. *Scarless Wound Healing*. New York: Marcel Dekker, 2000:161–171.
27. Kischer CW, Shetlar MR, Shetlar CL, et al. Immunoglobulins in hypertrophic scars and keloids. *Plast Reconstr Surg* 1983; 71:821–825.
28. Koc E, Arca E, Surucu B, et al. An open, randomized, controlled, comparative study of the combined effect of intralesional triamcinolone acetonide and onion extract gel and intralesional triamcinolone acetonide alone in the treatment of hypertrophic scars and keloids. *Dermatol Surg* 2008; 34:1507–1514.
29. Kurwa AR. Rubinstein-Taybi syndrome and spontaneous keloids. *Clin Exp Dermatol* 1979; 4:251–254.
30. Lane JE, Waller JL, Davis LS. Relationship between age of ear piercing and keloid formation. *Pediatrics* 2005; 115:1312–1314.
31. Lawrence WT. Treatment of earlobe keloids with surgery plus adjuvant intralesional verapamil and pressure earrings. *Ann Plast Surg* 1996; 37:167–169.
32. Lee R, Ping J. Calcium antagonists retard extracellular matrix production in connective tissue equivalent. *J Surg Res* 1990; 49:463–466.
33. Lee RC, Doong H, Jellem AF. The response of burn scars to intralesional verapamil. Report of 5 cases. *Arch Surg* 1994; 129:107–111.
34. Mandal A, Imran D, Rao GS. Spontaneous keloids in siblings. *Ir Med J* 2004; 97:250–251.
35. Marneros AG, Norris JEC, Olsen BR, et al. Clinical genetics of familial keloids. *Arch Dermatol* 2001; 137:1429–1434.
36. Menezes N, Moreira A, Furtado A, et al. Eruptive keloids: spontaneous reactivation after 60 years. *Dermatol Online J* 2009; 15.
37. Murray JC. Scars and keloids. *Dermatol Clin* 1993; 11:697–707.
38. Murray JC, Pinnell SR. Keloids and excessive dermal scarring. In: Kelman Cohen I, Diegelmann RF, Lindblad WJ, eds. *Wound Healing: Biochemical and Clinical Aspects*. Philadelphia, PA: WB Saunders Company, 1992:500–509.
39. Nemeth AJ. Keloids and hypertrophic scars. *J Dermatol Surg Oncol* 1993; 19:738–746.
40. Niessen FB, Spauwen PH, Schalkwijk J, et al. On the nature of hypertrophic scars and keloids: a review. *Plast Reconstr Surg* 1999; 104:1435–1458.
41. Panabiere-Castaings MH. Retinoic acid in the treatment of keloids. *J Dermatol Surg Oncol* 1988; 14:1275–1276.
42. Partington MW. Rubinstein-Taybi syndrome: a follow-up study. *Am J Med Genet Suppl* 1990; 6:65–68.
43. Rockwell WB, Cohen IK, Ehrlich HP. Keloids and hypertrophic scars. A comprehensive review. *Plast Reconstr Surg* 1989; 84: 827–837.
44. Rudolph R. Wide spread scars, hypertrophic scars and keloids. *Clin Plast Surg* 1987; 14:253–260.
45. Rusciani L, Rossi G, Bono R. Use of cryotherapy in the treatment of keloids. *J Dermatol Surg Oncol* 1993; 19:529–534.
46. Selmanowitz VJ, Stiller MJ. Rubinstein-Taybi syndrome. Cutaneous manifestations and colossal keloids. *Arch Dermatol* 1981; 117: 504–506.
47. Stegman SJ, Tromovitch TA, Glogan RG. Treatment of keloids. In: Stegman SJ, eds. *Cosmetic Dermatologic Surgery*. 2nd ed. Chicago: Year Book Medical, 1990:201–206.
48. Suzawa H, Kibuchi S, Arai N, et al. The mechanism involved in the inhibitory action of tranilast on collagen biosynthesis of keloid fibroblasts. *Jpn J Pharmacol* 1992; 60:91–96.
49. Ulrich D, Ulrich F, Unglaub F, et al. Matrix metalloproteinases and tissue inhibitors of metalloproteinases in patients with different types of scars and keloids. *J Plast Reconstr Aesthet Surg* 2009; 1–7.
50. Waki EY, Crumley RL, Jaowatz JG. Effects of pharmacologic agents on human keloids implanted in thymic mice. *Otolaryngol Head Neck Surg* 1991; 117:1177–1181.
51. Wolfram D, Tzankov A, Pulzl P, et al. Hypertrophic scars and keloids—a review of their pathophysiology, risk factors, and therapeutic management. *Dermatol Surg* 2009; 35:171–181.
52. Younai S, Ventors G, Vu S, et al. Role of growth factors in scar contraction: an in vitro analysis. *Ann Plast Surg* 1996; 36:495–501.
53. Zouboulis CC, Blume U, Buttner P, et al. Outcomes of cryosurgery in keloids and hypertrophic scars. *Arch Dermatol* 1993; 129: 1146–1151.
54. Zurada JM, Kriegel D, Davis IC. Topical treatments for hypertrophic scars. *J Am Acad Dermatol* 2006; 55:1024–1031.

## Keratolytic treatment of acne

Ali Alikhan and Howard I. Maibach

### INTRODUCTION

Topical keratolytic agents have long been employed for acne treatment. Shalita et al. state that “the first histologically visible change in acne is a disruption in the normal pattern of keratinization, resulting in dense, coherent squamiae of keratinous material that accumulate to form a plug in the orifice of the follicle, leading to formation of the microcomedo” (precursor acne lesion). Furthermore, these aberrancies in proliferation, adhesion, and differentiation of the keratinocytes obstruct the infundibulum and the sebaceous duct, paving the way for excessive sebum secretion, bacterial overgrowth, and inflammatory response due to release of bacterial and cellular products.

Under light microscopy, microcomedones are visualized as layers of horny cells surrounding a sebum and bacteria core (1). Keratolytic agents are thought to function by relaxing the cohesiveness of the stratum corneum layer, which serves as a crucial, life-sustaining barrier, keeping hydration “in” and harmful foreign agents “out.” The mechanism of action does not involve keratin lysis as the name implies, but rather disintegration of desmosomes and hemidesmosomes that link keratinocytes and bind them to the extracellular matrix, respectively (2). In this manner, these agents modulate and correct abnormal follicular keratinization.

Currently many classes of keratolytics exist (Table 40.1). Available in varying concentrations and vehicles, they may be specifically indicated depending on the type, duration, and severity of acne. This chapter covers widely available, topical and oral keratolytics, controlled trials comparing keratolytic agents, and in vivo keratolytic protein assays. Uncontrolled trials and older acne treatments are discussed briefly.

This overview was based on PubMed, Embase, and Science Citation Index utilizing the following words: keratolytics, benzoyl peroxide, azelaic acid, retinoids, sulfur, resorcinol, glycolic acid, salicylic acid, acne vulgaris.

### BENZOYL PEROXIDE

Benzoyl peroxide (BPO), a mainstay treatment of mild-to-moderate acne for decades, has antimicrobial, anti-inflammatory, and anticomedogenic effects. Acting through oxidation and formation of free radicals, its bacteriostatic activity is superior even to that of topical antibiotics (4). It decreases inflammation by killing polymorphonuclear leukocyte (PMNs), preventing the release of reactive oxygen species (5), and was shown to be a keratolytic in vivo (Table 40.4). Unfortunately, oxidative destruction of the stratum corneum may deplete cutaneous vitamin E, resulting in oxidation of surface lipids and proteins; this may predispose to skin dryness and desquamation (6).

BPO is absorbed effectively into the epidermis, particularly by pilosebaceous units, and converted to benzoic acid,

with approximately 2% entering the systemic circulation (7–9). Its lipophilicity allows it to enter and accumulate in the lipid-rich pilosebaceous units and subcutaneous fat (5). It is an FDA Pregnancy Category C agent, with little known about potential fetal harm or breast milk excretion, and positive in the rodent photocarcinogenicity assay.

It is widely available, both over-the-counter and by prescription, and comes in different concentrations ranging from 2.5% to 10%. Adverse effects include dryness, peeling, burning, and redness of skin, with contact allergy in 1% to 2% of patients (4). To that end, patients should avoid excessive UV radiation, which can exacerbate irritation. Additionally, the water-based formulations may exert less drying, scaling, burning, and erythema than the alcohol-based formulations (4,10). Of note, BPO, an oxidizing agent, can bleach hair, clothes, and colored fabrics. It may also inactivate tretinoin if both are applied concurrently (11); in contrast, adapalene and tazarotene remain stable in the presence of BPO (7).

The 2.5% formulation may be as effective as the 5% and 10% formulations in reducing inflammatory lesions and producing positive global ratings, while causing fewer adverse reactions than the 10% solution (12). Compared with vehicle, 2.5% BPO significantly decreased inflammatory lesions and improved global ratings; by the end of the eight-week study, the only significant adverse effect was peeling (12). In a split-face, double-blind trial, a combination of BPO 5% and urea 8% lotion was not more efficacious in diminishing acne than BPO 5% lotion alone; the combination took longer to dry and was stickier according to subjects (13).

Despite disappointing results with urea, combination therapy with topical antibiotics and BPO may be more effective than BPO alone. Both the clindamycin/BPO and the erythromycin/BPO formulations (Table 40.1) have shown superior efficacy when compared with either the antibiotic or BPO alone (14). Three well-designed, randomized, double-blind, vehicle-controlled, multicenter clinical trials comparing the clindamycin/BPO gel with each individual agent and vehicle demonstrated significantly superior efficacy in inflammatory lesion reduction after 10 to 16 weeks (5). In two of the trials, global improvement assessments demonstrated significantly greater improvement in the combination group. Furthermore, the side effect profile (dry skin, peeling, and erythema) of combination therapy is comparable to that of BPO alone (5).

Leyden et al. compared clindamycin/BPO and erythromycin/BPO demonstrating statistically equivalent lesion reduction and global improvement, with similar tolerability (15). Additionally, a vehicle-controlled, randomized trial examining a 5% BPO/1% clindamycin combination gel in acne rosacea demonstrated significant improvement in papules/pustules and flushing/blushing after just a few weeks (16).

**Table 40.1** Keratolytics Currently Used in the United States

Name	Class	First introduced	Concentration(s) (%)	Vehicle(s)
Salicylic acid	$\beta$ -Hydroxy acid	–	2.0	Bar, foam
Glycolic acid	$\alpha$ -Hydroxy acid	–	–	–
Benzoyl peroxide	Organic peroxide	1920s	2.5, 3.0, 4.0, 5.0, 6.0, 8.0, 8.5, 9, 10	Gel, liquid, bar
Tretinoin	Retinoid	1962	0.025, 0.05, 0.1, 0.01, 0.025, 0.05, 0.04	Cream, gel, liquid
Isotretinoin	Retinoid	1979	10 mg, 20 mg, 30 mg, 40 mg	Oral
Tazarotene	Retinoid	1997	0.1, 0.05, 0.5	Gel, cream
Adapalene	Retinoid-like	1996	0.1	Gel, cream, pledgets, solution
Azelaic acid	Dicarboxylic acid	–	15.0, 20.0	Cream, gel
Sulfur	Sulfur	–	10.0	Bar
Urea	Urea	–	–	–
Resorcinol	Phenol	–	–	–
Clindamycin/benzoyl peroxide	Antibiotic combination	–	1.0/5.0	Gel
Erythromycin/benzoyl peroxide	Antibiotic combination	–	3.0/5.0	Gel
Sulfur/sodium sulfacetamide	Antibiotic combination	–	5.0/10.0	Tube, gel, cream, lotion
Benzoyl peroxide/urea	Keratolytic combination	–	4.5/10.0, 8.5/10.0	Liquid, gel
Sulfur/benzoyl peroxide	Keratolytic combination	–	2.0/5.0, 5.0/10.0	Lotion

Source: From Ref. 3.

These results suggest a viable alternative to traditional rosacea treatments, which can produce systemic side effects.

In vivo data suggest that the increased efficacy of a BPO/antibiotic combination may have an immunological basis as demonstrated by decreased antioxidant enzyme activities in leukocytes after month-long combination treatment (17). Additionally, this combination approach may prevent the evolution of resistant *Propionibacterium acnes* strains (18).

### RETINOIDS: TRETINOIN, TAZAROTENE, ADAPALENE

Topical retinoids encompass a group of powerful, comedolytic, anticomedogenic, and anti-inflammatory agents. They are powerful keratolytics, targeting both primary and secondary prevention of comedones. Additionally, oral isotretinoin also reduces sebaceous gland size and suppresses sebum production (7).

Retinoids exert their effects through nuclear receptor families RARs (retinoic acid receptors) and RXRs (retinoic X receptors), subsequently inducing retinoic acid-responsive target gene expression (19–21). Both receptor families are ligand-dependent transcription factors and consist of three receptor subtypes ( $\alpha$ ,  $\beta$ , and  $\gamma$ ), encoded by three separate genes (22).

Although RAR- $\alpha$  is ubiquitous in embryonic skin, RAR- $\gamma$  is the most abundant RAR in human epidermis, cultured keratinocytes, and dermal fibroblasts (22,23). Retinoids also inhibit expression of certain genes by downregulating other transcription factors, notably activator protein 1 (AP-1) and nuclear factor-interleukin 6 (NF-IL6) (19). This inhibitory action may be partly responsible for the anti-proliferative and anti-inflammatory actions of retinoids (22).

Prior to binding with nuclear RARs, retinoids must first bind to intracellular proteins. Cellular retinoic acid proteins (CRABP I and II) are present in the skin. Intracellular retinoid concentrations are dependent on CRABP, primarily type II (19). However, CRABP II is not essential for biological retinoid activity as adapalene does not bind to it; interestingly, it may play a role in retinoid-induced epidermal irritation (22).

Through this genetic regulation, retinoids are thought to affect cellular differentiation and proliferation (20). Experimental studies, some using primary neonatal mouse epidermal keratinocyte cultures, have confirmed this concordant decrease in keratinocyte differentiation and proliferation (24). Retinoids also regulate activity of keratinocyte adhesion and cohesion molecules, resulting in breakdown and obliteration of the horny plug (23).

Mechanisms of action are numerous and include normalization of epidermal proliferation and differentiation, inhibition of neutrophil chemotaxis, expression of toll-like receptors (TLRs) involved in immunomodulation, and anti-inflammatory effects via inhibition of prostaglandins, leukotrienes, and interferon (IFN)- $\gamma$  release. Retinoids may exert an anti-inflammatory response by inhibiting the release of proinflammatory cytokines (interleukins 12 and 8 and tumor necrosis factor) via downregulation of monocyte TLRs (25,26). Interestingly, *P. acnes* acts through TLR-2 to stimulate proinflammatory cytokine production (27). Additionally, retinoids cause the hair follicle to become less anaerobic, creating a more hostile environment for *P. acnes* (22).

Combination therapy involving topical retinoids and antimicrobials allows targeting of different pathophysiological factors in acne vulgaris (19). This combination approach is optimal in patients with both inflammatory and comedonal lesions, given the different but complementary mechanisms of action present in both agents (19). Additionally, topical retinoid therapy, by weakening the horny layer barrier, may increase skin permeability, enhancing penetration of antimicrobial agents. Increased cell turnover of follicular epithelium enables greater access of antibiotic into the canal that houses *P. acnes*.

A large retrospective, vehicle-controlled study of inflammatory acne (mild/moderate to severe) demonstrated clinically significant improvements with tazarotene 0.1% gel and 0.1% cream, adapalene 0.1% gel, and tretinoin 0.1% microsphere treatment (25). These treatments along with tretinoin 0.025% gel produced significant improvement in global acne response (25). Among these, tazarotene 0.1% cream and 0.1% gel showed a greater frequency of clinically significant improvement when



compared with adapalene or tretinoin gel (25). Between-retinoid comparisons demonstrated tazarotene to have the greatest efficacy on the overall inflammatory acne severity and global response scales (25).

The major drawback to topical retinoids is local skin irritation and acne exacerbation, also termed "retinoid flare," which may occur during the first month of treatment and last several weeks (7). This flare-up may be secondary to release of follicular inflammatory factors after topical retinoid treatment (28).

Another limiting factor of retinoids, particularly oral agents, is their teratogenicity, resulting in severe fetal malformations if exposure occurs during the first trimester. Malformations include microtia/anotia, conotruncal heart defects and aortic arch abnormalities, thymic defects, and central nervous system malformations (29). Several case reports suggest these effects may not be limited to oral retinoid therapy, with limb-reduction defects and ear malformations reported with maternal use of topical retinoids (30,31). However, Jick et al., in a retrospective study, did not substantiate this suggestion, and the clinical issue remains subjudice (32).

## Tretinoin

Tretinoin, the first topical retinoid to be studied, binds with high activity to all three RAR subtypes and to CRABP, and with low activity to RXRs. It is an effective comedolytic agent, which increases epithelial cell turnover and modulates abnormal keratinization (that leads to microcomedone formation). It also acts in an anticomedogenic manner, preventing formation of microcomedones (22). Mills and Kligman, using a cyanoacrylate follicular biopsy technique, demonstrated a profound microcomedone reduction in 8 and 12 weeks (33). From an immunological perspective, *in vitro* studies have demonstrated that tretinoin downregulates and decreases surface expression of TLR-2 and CD14 mRNA, preventing secretion of interleukins (perhaps IL-1 $\alpha$ , 12, and 8), tumor necrosis factor, and IFN- $\gamma$ , as well as production of free radicals (23,24).

In a large multicenter trial, 0.025% tretinoin cream significantly reduced inflammatory and noninflammatory acne lesions compared with vehicle by week 12; side effects included eruption, dry skin, and exfoliation (34) (Table 40.2). Polyolpre-polymer-2 (PP-2), which localizes drug molecules in upper skin layers, preventing deep penetration, may diminish adverse cutaneous reactions (34). A large study demonstrated earlier favorable global assessments with 0.025% tretinoin with PP-2 cream versus a 0.025% tretinoin cream, but no significant difference in side effects (34). PP-2 forms a liquid reservoir of polymer and solubilized drug on the skin surface, slowing percutaneous absorption and transcellular cutaneous diffusion, potentially targeting folliculo-infundibular delivery in the process (35). Some clinical trials have demonstrated reduced irritation as less drug penetrates the skin (35).

The Microsponge Delivery System found in 0.1% microsphere gel also helps reduce drug release rate and increase drug retention in the stratum corneum (SC), inhibiting deeper penetration (7). Tretinoin is trapped within porous copolymer microspheres, which selectively localize to the follicle, releasing tretinoin over time and producing less irritation (than the standard 0.025% cream) due to reduced concentration on the skin (23). A study examining tretinoin gel microsphere 0.04% compared with vehicle demonstrated significant reduction in total, inflammatory, and noninflammatory acne by week 12 (26).

About 90% of subjects reported none or only mild adverse events; there were no significant differences in tolerability between the treatment and control groups at week 12 (26). Moreover, tretinoin 0.1% microsphere gel significantly reduces facial shine at three and six hours posttreatment when compared with tretinoin 0.025% cream (36).

Numerous trials have demonstrated the efficacy of tretinoin in various forms of acne. Patience is advised as full effect may take two to four months; adherence is essential as tretinoin serves to control rather than cure acne. A hydrogel containing 1% clindamycin and 0.025% tretinoin was found to be more efficacious in treating inflammatory and noninflammatory acne lesions than either agent alone or vehicle (37). These results were confirmed by two large studies; adverse effects were similar in frequency and severity to tretinoin alone (37). Furthermore, a BPO 6% cleanser-tretinoin 0.1% microsphere gel demonstrated significantly greater inflammatory lesion reduction than tretinoin alone (38).

In a split-face ultrastructural study comparing 0.1% tretinoin to emollient cream, an 80% decrease in microcomedones was demonstrated on the tretinoin side at 12 weeks (1). Employing the technique of skin surface biopsy, microscopic examination of comedones showed progressive loss of the cohesiveness and significant alterations in epithelial structure; thick keratinous plugs infested with bacteria were transformed into a few wispy layers of keratin with few bacteria (1). Using transmission electron microscopy, it was possible to track microcomedones with compact, adherent stratum corneum morphing into spongy, loosely adherent layers of corneocytes (1). From a combination therapeutic standpoint, the alteration in SC integrity incurred during tretinoin treatment may enhance penetration of other agents such as BPO and topical antibiotics (see paragraph above) (1).

Surprisingly, topical tretinoin has poor percutaneous absorption and does not alter systemic retinoid levels, which stay constant despite application (7). Side effects include peeling, erythema, dryness, burning, and itching (7,23). Pustular eruptions may occur initially, but are alleviated with concomitant erythromycin (23). Additionally, tretinoin may bring out the postinflammatory darkening that occurs in healing acne of darker-skinned patients (28). Tretinoin-induced skin irritation may be explained by a flexible chemical structure, resulting in nonselective action, and the ability to activate numerous pathways, resulting in various biological effects (22). Applying a moisturizing cream along with topical tretinoin or oral tretinoin significantly improves skin dryness, roughness, and desquamation, increasing subjective skin comfort (39).

Adverse effects are exacerbated by sunlight, extremes in weather, oxygen, and "comedogenic" skincare products. They can be reduced by spacing out applications and/or diminishing frequency and concentration of the product (23). Additionally, tretinoin should not be used with BPO (an oxidizing agent), which can result in degradation and deactivation. Despite some evidence to the contrary, topical tretinoin is not advised during pregnancy and lactation. Potential for systemic exposure and excretion in breast milk have not been adequately studied.

## Isotretinoin

Introduced in the late 1970s, isotretinoin (Iso) remains a mainstay for severe, recalcitrant nodulocystic acne unresponsive to topical therapy and systemic antibiotics. Dramatic clearing and prolonged remissions of lesions make Iso an attractive

**Table 40.2** Controlled Clinical Trials Comparing Keratolytic Agents in Acne Vulgaris Treatment

Authors	Comparison	Lesions	Placebo	Results, brief
Lucky et al. 1998 (34)	0.025% Tretinoin gel vs. 0.025% tretinoin gel containing polyolprepolymer-2 vs. vehicle over 12 wk	All types	Vehicle	Both treatments significantly more effective than vehicle. Polyolprepolymer-2 treatment has significantly less peeling and drying.
Cunliffe et al. 1998 (58)	Meta-analysis of five 12-wk long randomized trials comparing 0.1% adapalene gel vs. 0.025% tretinoin gel	All types	Vehicle only in 1 study	Both treatments had equivalent efficacy in reducing lesion count; adapalene works more rapidly with greater tolerability.
Bershad et al. 2002 (55)	12-wk trial comparing 0.1% tazarotene gel once daily vs. 0.1% tazarotene gel twice daily in short-contact (<5 min) application vs. vehicle twice daily	All types	Vehicle	Both groups were comparable and significantly more efficacious than vehicle
Lookingbill et al. 1997 (14)	Combined results of two double-blind, 11-wk long, randomized trials comparing 1% clindamycin/5%BPO gel, 1% clindamycin gel, 5% BPO gel, and vehicle	All types	Vehicle	All 3 treatments were significantly better than vehicle. Combination gel was significantly superior to 2 individual agents in global improvement and reduction of inflammatory lesions; it was also better than clindamycin in treating noninflammatory lesions.
Shalita et al. 1999 (20)	Multicenter, controlled, 12-wk long trial comparing 0.05% tazarotene gel vs. 0.1% tazarotene gel vs. vehicle	All types	Vehicle	At 12 wk, both tazarotene gels produced significant success rates and decreased total and noninflammatory lesions. Only 0.1% gel significantly reduced inflammatory lesions; it was also significantly more efficacious than 0.05% gel, with decrease in total and noninflammatory lesions and success rates
Leyden et al. 2005 (25)	Retrospective, vehicle-controlled, photographic assessment comparing tazarotene 0.1% gel, adapalene 0.1% gel, tretinoin 0.1% microsphere, tretinoin 0.025% gel, and tazarotene 0.1% cream	Inflammatory	Vehicle	All treatments had significant improvement in global response compared with vehicle. All except tretinoin gel had clinically significant improvement in inflammatory acne. Between-retinoid comparisons demonstrated tazarotene to have significantly greater incidences of clinically significant improvement compared with adapalene or tretinoin gel.
Leyden et al. 2005 (25)	Combined results of two double-blind, randomized, 12- or 15-wk long trials comparing 0.025% tretinoin/1% clindamycin hydrogel with each agent alone and vehicle	All types	Vehicle	All treatments were more efficacious than vehicle. Combination treatment was more efficacious in treating inflammatory and noninflammatory lesions compared with either agent alone, and its side effect profile was similar to tretinoin.
Galvin et al. 1998 (60)	Two controlled, randomized studies comparing 0.1% adapalene gel with a total of 6 different tretinoin formulations and petrolatum in terms of tolerability after 3 wk	—	Petrolatum	Adapalene had a better tolerability profile than tretinoin 0.1% cream, tretinoin 0.05% cream, tretinoin 0.025% cream, tretinoin 0.01% gel, tretinoin 0.025% gel, and tretinoin 0.1% gel microsphere, and an equivalent tolerability to petrolatum.
Chalker et al. 1987 (43)	Multicenter, controlled study comparing Iso 0.05% gel twice daily for up to 14 wk with its vehicle	Mild-to-moderate acne	Vehicle	Iso gel was significantly more effective in reducing inflammatory lesions after 5 wk, and noninflammatory lesions and acne severity grade after 8 wk. 2 Iso patients dropped out due to skin irritation.
Mills et al. 1986 (12)	3 Double-blind, 8-wk long studies comparing 2.5% BPO, 5% BPO, 10% BPO, and vehicle	Mild to moderately severe inflammatory acne	Vehicle	2.5% BPO formulation was more effective than vehicle and equivalent to 5% and 10% concentrations in reducing the number of inflammatory lesions; 2.5% formulation had less desquamation, erythema, and burning than the 10% preparation, but tolerability was equivalent to the 5% gel.

(Continued)

**Table 40.2** Controlled Clinical Trials Comparing Keratolytic Agents in Acne Vulgaris Treatment (*Continued*)

Authors	Comparison	Lesions	Placebo	Results, brief
Katsambas et al. 1989 (69)	3-mo double-blind study comparing 20% azelaic acid cream to its vehicle	Moderate inflammatory acne	Vehicle	At 2 and 3 mo, azelaic acid showed significant improvement in reducing inflammatory lesions compared with its vehicle. Azelaic acid showed significant comedone reduction compared with its vehicle in all visits. There was also a significant difference in overall evaluation. The only significant side effect difference was burning sensation.
Shalita 1981 (74)	12-wk trial comparing 0.5% salicylic acid in an alcoholic detergent solution (Stri-Dex medicated pads) vs. placebo (pads soaked in buffered water)	Mild-to-moderate acne	Vehicle	The treatment group experienced significant reductions in inflammatory lesions and open comedones compared with the placebo group. The treatment group also had significantly more "good" or "excellent" responses than the placebo group.
Spellman and Pincus, 1998 (28)	12-wk double-blind, randomized trial comparing azelaic acid 20% cream-glycolic acid solution with tretinoin 0.025% cream and vehicle lotion	Mild-to-moderate acne	Vehicle	Both groups experienced significant lesion reduction and global improvement compared with vehicle. The combination treatment was significantly better in decreasing inflammatory lesions than tretinoin, while producing significantly fewer adverse effects. Both treatments had equivalent noninflammatory lesion reduction.
Thiboutot et al. 2007 (27)	12-wk randomized, double-blind trial comparing combination adapalene 0.1% gel-BPO 2.5% gel vs. adapalene 0.1% gel vs. BPO 2.5% gel vs. vehicle	Inflammatory and noninflammatory	Vehicle	The combination was significantly more effective than the monotherapies in investigator's global assessment and reduction of inflammatory, noninflammatory, and total lesions. Tolerability of combination treatment was similar to adapalene monotherapy.
Thiboutot et al. 2006 (57)	12-wk randomized vehicle-controlled study comparing 0.3% adapalene gel to 0.1% adapalene gel	Inflammatory and noninflammatory	Vehicle	Adapalene 0.3% gel was significantly superior to 0.1% gel in various efficacy assessments, total lesion reduction, and inflammatory lesion reduction. Tolerability profile was similar in both concentrations.

*Abbreviations:* BPO, benzoyl peroxide; Iso, isotretinoin.

treatment modality (19). Its efficacy extends beyond correction of hyperkeratinization to include actions on the sebaceous gland (decreases size and secretion), anticomedogenic properties, and reduction of *P. acnes* via creation of an unfavorable follicular environment (40). Its cellular actions are not completely known, and it does not display strong binding activity to RAR or RXR nuclear receptors (23).

A cumulative dose of 100 to 150 mg/kg is recommended during treatment course, with daily dosage ranging from 0.5 to 1 mg/kg/day (23). Lower daily doses may be associated with higher rates of relapse (23). In fact, Cunliffe and Norris cite several studies including their own that demonstrate a significantly higher relapse rate in subjects receiving 0.5 mg/kg/day compared with that receiving 1.0 mg/kg/day (41). Nonetheless, to assuage possible retinoid flare, doses of 0.5 mg/day for the first month may be prudent (40).

At doses of 1 mg/kg/day for four months, Iso treatment produces significant decreases in sebum excretion rate in comedo formation (41). Risk factors for suboptimal response to Iso include younger age (14–19 years), acne duration of less than six years, increased truncal acne, and a return of reduced sebum excretion rate to within 10% of the pretreatment level

(41). Lesions on the face, upper arms, and legs respond more favorably than those on the trunk (40).

No other local or generalized acne treatment is to be taken simultaneously with Iso. Intervals between treatments can be spaced out, thus improving side effect profile and minimizing drug exposure. In a large trial, micronized Iso demonstrated fewer adverse mucocutaneous events and a lower likelihood of triglyceride elevation than standard Iso (42).

In the United States, Iso is prescribed solely as an oral agent, although several other countries have a topical option. A large, multicenter, double-blind, controlled study demonstrated Iso 0.5% gel to be significantly more effective than vehicle in reducing inflammatory lesions, noninflammatory lesions, and acne severity grade by eight weeks (43). Despite significantly greater likelihood of erythema and peeling in the Iso group compared with vehicle, most of the patients had little or no local irritation; additionally, retinoid flare, seen with tretinoin, was not observed with the Iso formulation (43).

A 2007 trial indicated a place for intermittent Iso treatment for those with moderate acne, resulting in significantly fewer side effects (mucosal dryness, dry/chapped lips, and rash/facial redness) (44). The intermittent schedules included

**Table 40.3** Uncontrolled Clinical Trials Comparing Keratolytic Agents in Acne Vulgaris Treatment

Authors	Comparison	Lesions	Placebo	Results
Akman et al. 2007 (44)	Isotretinoin for first 10 days of each month for 6 mo vs. each day in first month and first 10 days of each month for 5 mo vs. daily for 6 mo	Moderate and severe	None	Acne scores were significantly lower for all groups posttreatment. No difference in groups for total lesions, but daily was more effective than intermittent for severe acne. Daily treatment also demonstrated significantly greater SE profile.
Leyden et al. 2001 (15)	10-wk trial comparing 5% BPO/1% clindamycin, 5% BPO, and 5% BPO/3% erythromycin	Moderate to moderately severe	None	All treatments had significantly reduced noninflammatory acne reduction. BPO/clindamycin had significantly greater reduction in inflammatory lesions and greater overall improvement rated by physicians and patients compared with BPO. Efficacy was statistically similar to BPO/erythromycin. SE of BPO/clindamycin similar to BPO alone.
Katsambas et al. 1989 (69)	6-mo trial comparing 20% AA cream and 0.05% tretinoin cream	Comedonal but patients had both	None	Similar decreases in comedone and total lesion count as well as overall response rate. AA had significantly fewer side effects.
Cavicchini and Caputo, 1989 (70)	6-mo single-blind trial comparing 20% AA cream vs. 5% BPO gel	Papulopustular acne	None	BPO more rapid initially, but by 4 mo equal inflammatory lesion reduction and overall response; additionally, BPO had more intense and longer-lasting side effects
Korkut and Piskin, 2005 (61)	Open-labeled, prospective study comparing 0.1% adapalene gel, 5% BPO lotion, or combination of 0.1% adapalene gel + 5% BPO treatment	Noninflammatory and inflammatory	None	All three treatments were effective in treating noninflammatory and inflammatory lesions but there was no significant difference between them in efficacy or side effects.
Tanghetti et al. 2006 (56)	Multicenter, randomized, 12-wk long trial comparing tazarotene 0.1% cream once daily vs. tazarotene 0.1% cream once daily + 1% clindamycin/5% BPO gel once daily	Moderate-to-severe inflammatory acne	None	Combination therapy resulted in significantly greater comedone reduction than tazarotene alone. In patients with >25 inflammatory lesions, combination therapy also resulted in a significant inflammatory lesion reduction. Both were equally well tolerated.

*Abbreviations:* BPO, benzoyl peroxide; AA, azelaic acid; SE, side effect.

in the trial were Iso 0.5 mg/kg/day for the first 10 days each month for 6 months, or each day in the first month and the first 10 days of each month for the next 5 months (Table 40.3). Nevertheless, in severe acne, consistent daily usage (Iso 0.5 mg/kg/day for 6 months) displayed greater efficacy than intermittent usage patterns (44). From an epidemiological standpoint, between 1993 and 2000 in the United States, the proportion of Iso treatment for severe acne dropped from 63% to 46%, while the proportion of treatment for mild and moderate acne increased from 31% to 49% (23).

Orally, Iso is a potent teratogen. To date, several reports of congenital abnormalities have been reported. One large investigation involving 154 pregnancies with fetal exposure to oral Iso resulted in 12 spontaneous abortions and 21 major malformations involving craniofacial, cardiac, thymic, and neural structures (7). Even short-term treatment can lead to congenital defects, resulting in an FDA Category X classification. Furthermore, women of childbearing age must use two forms of contraception concurrently, demonstrate two negative pregnancy tests prior to treatment, undergo monthly urinary pregnancy tests, and understand potential hazards of treatment (culminating in an informed consent).

A large Canadian study determined the annual rate of pregnancy during Iso treatment to be 32.7/1000 person-years of treatment, four times greater than what had been previ-

ously published (45). Furthermore, predictors of becoming pregnant on Iso therapy were low socioeconomic status (SES) and high health care services usage (45). Congenital malformations occurred in only 11% of completed pregnancies, which Berard et al. comment is two-third smaller than what other studies have demonstrated (45).

Eruptive inflammatory attacks are common during the first month of therapy, typically resolving without further sequelae. The most commonly reported adverse effects are mucocutaneous and cutaneous changes/dryness involving the lips, eyes, mouth, and other mucosal surfaces (40,42). Cheilitis, dry skin, and localized exfoliation were the most commonly reported adverse events in a large study (42). Secondary skin infection with *Staphylococcus aureus* can occur, and must be treated with antibiotics (40).

Far more serious side effects include hyperlipidemias, pseudotumor cerebri, hyperostosis, hepatotoxicity, premature epiphyseal closure, and inflammatory bowel disease (IBD) (7). Routine monitoring of serum lipids and LFTs is an important corollary of Iso treatment (40). A number of ophthalmological effects, including poor night vision, reversible corneal opacities, and excessive glare, have been associated with Iso. As Iso is a vitamin A analogue, interference with the retinol pathway (namely, retinal retinol dehydrogenase), paramount in photoreceptor function, may be to blame (9,46).

There is evidence, though inconclusive, of an association between depression and suicide in some patients (47). Most of this evidence is from case reports and small studies, and suggests resolution of depression shortly after treatment is discontinued (48). Pooling of this data suggests a mean treatment duration of 14 weeks prior to onset of depression (48). Additionally, RARs are located in the CNS and may respond to retinoid treatment for acne. Iso ranked within the top 10 for number of depression reports and suicide attempts in the FDA's Adverse Event Reporting System database to June 2000; in the 18-year period since its introduction, 431 reports of depression, suicidal ideation, suicide attempts, and completed suicide have been reported (47).

However, several studies have failed to demonstrate a correlation between Iso use and depression (42,49). A large population-based cohort study examined the Iso-depression/suicide association in the Canadian Saskatchewan Health Database and the United Kingdom General Practice Research Database (50). The study involved data from over 20,000 subjects, resulting in no evidence of an association between Iso use and increased risk for depression, suicide, or other psychiatric disorders (neurotic and psychotic disorders) (50). In fact, small studies have demonstrated improvement of psychiatric symptoms (depression and anxiety) with Iso use, especially in those with marked clinical improvement in their facial acne (48,51). Despite the controversy, physicians should inform patients to be cognizant of signs of depression, irritability, and suicidal ideation.

Furthermore, increased serum levels of 8-OHdG (a serum marker for DNA oxidative damage) were present in 18 subjects administered Iso (52). This may be due to indirect action through free radical production and/or direct action of Iso on liver, muscle, or skin epidermal cells (52).

### Tazarotene

Tazarotene, a topical acetylenic retinoid indicated in both psoriasis and acne vulgaris, is hydrolyzed by keratinocyte esterases to tazarotenic acid, its active metabolite (19). It binds all three RARs, but activates gene expression only in RAR- $\beta$  and - $\gamma$ ; downregulation of AP-1 and lack of RXR binding are observed (19,22,53). In doing so, it normalizes the keratinization pattern and decreases coherence of follicular keratinocytes, manifesting both comedolytic and anticomedogenic properties (20). Tazarotene also has anti-inflammatory properties (20). In the systemic circulation, tazarotenic acid is rapidly converted to inactive sulfur-oxidized forms, resulting in limited exposure (53).

A randomized, double-blind, vehicle-controlled study demonstrated that 0.05% and 0.1% tazarotene gels significantly decrease total lesions, decrease noninflammatory lesions, and produce a higher success rate than vehicle at 12 weeks (20). Moreover, 0.1% gel was significantly more efficacious than 0.05% gel, and demonstrated a significant decrease in inflammatory acne at 12 weeks (20). A more recent randomized trial comparing tazarotene 0.1% cream to adapalene 0.1% cream demonstrated tazarotene to be significantly and rapidly more effective in reducing comedone count and producing global improvement, with no significant difference in side effects at 12 weeks (20). Although, only noninflammatory lesions could be compared in this study, other studies have demonstrated efficacy in inflammatory lesions as well (54). Furthermore, a large clinical trial suggests that even short-contact application (<5 minutes), once daily for 12 weeks, produces significant reduction in both inflammatory and noninflammatory acne lesions (55).

With our armament of acne medications, standard acne treatment now involves using multiple agents, each with its own mechanism of action. To that end, a multicenter, double-blind, randomized trial found a daily 5% BPO/1% clindamycin gel-tazarotene 0.1% cream regimen to be more effective than daily tazarotene monotherapy in reducing comedo count and inflammatory lesion count (in those with  $\geq 25$  baseline inflammatory lesions), with a similar, if not slightly improved, tolerability profile (56).

Currently, only the 0.1% formulation of tazarotene is approved by the FDA for acne; it is primarily used in cases of acne refractory to tretinoin and adapalene treatment (7). Nonetheless, animal studies have demonstrated that tazarotene has low systemic absorption with no toxic effects even at high topical doses (53). Additionally, after 12 weeks of normal tazarotene application, serum samples from 22 subjects demonstrated limited systemic exposure with most below the quantifiable limit (<0.05 ng/mL) (20).

Local side effects typically occur; these include itching, burning, irritation, and erythema (7,20). In fact, tazarotene is thought to be the most irritating of the topical retinoids. In the Bershad study cited above, half of the patients applying tazarotene for only 2 to 10 minutes daily reported local skin irritation. These side effects are most common during the first two weeks of therapy; cream formulations, alternate-day application, and short-contact therapy can curtail side effects (23).

Despite little evidence of fetal malformations or spontaneous abortions, topical tazarotene is an FDA Pregnancy Category X drug; little is known about its excretion in breast milk. Of all topical retinoids in acne treatment, it is the only one requiring sufficient contraception in women of childbearing age (23).

### Adapalene

Adapalene, a derivative of retinoic acid, binds selectively to RAR- $\beta$  and - $\gamma$  *in vitro* but can activate gene expression through all three RARs; it does not bind CRABP II but increases CRABP II mRNA (19,22). It has comedolytic, antiproliferative, and anti-inflammatory properties (22). Its anti-inflammatory action stems from inhibitory effects on PMN chemotactic response, free radical production, and toll-like R2 receptors expressed by perifollicular monocytes (23). It also inhibits production of leukotrienes by 5- and 15-lipoxygenase pathways (22,23). Furthermore, adapalene may have a dose-dependent response, with 0.3% statistically superior to 0.1% in several different measures, while demonstrating equivalent tolerability (57).

A meta-analysis of five large randomized trials (composed of 900 patients) demonstrated equivalent acne reduction, quicker onset of action (significant at 1 week), and fewer side effects in 0.1% adapalene gel compared with that in 0.025% tretinoin gel (58). Side effect profile was significantly better in regards to scaling, erythema, dryness, immediate and persistent burning, and immediate pruritis (58). With its three aromatic rings, Adapalene demonstrates higher stability than tretinoin in the presence of light, in the dark, and with BPO (11). In a study comparing the chemical stability of 0.1% adapalene gel/10% BPO and 0.025% tretinoin gel/10% BPO after 24 hours of inactinic light exposure, approximately 100% of adapalene remained intact versus only 20% of tretinoin (59).

In a study examining two 21-day long trials, adapalene 0.1% gel demonstrated greater tolerability and significantly less irritation than tretinoin 0.1% cream, tretinoin 0.05% cream,

tretinoin 0.025% cream, tretinoin 0.01% gel, tretinoin 0.025% gel, and tretinoin 0.1% gel microsphere (60). Furthermore, in both studies, adapalene 0.1% gel was no more irritating than the petrolatum control (60). Favorable tolerability to adapalene may be explained by its receptor specificity, neutral molecular structure, and lack of breakdown products.

A study comparing 0.1% adapalene gel, 5% BPO, and a 0.1% adapalene/5% BPO combination demonstrated no significant difference between the groups in efficacy or side effects (erythema, dryness, or burning) (61). Additionally, all three treatments were significantly effective in reducing inflammatory and noninflammatory acne lesions (61). Adapalene reduced noninflammatory lesion counts by 68.75%, inflammatory lesion counts by 55.45% and total lesion counts by 65.48% (61). A more recent study testing a 0.1% adapalene/2.5% BPO combination gel against vehicle and individual monotherapies demonstrated combination therapy to have faster onset of action, significantly greater reductions in all lesion types, and no increase in adverse effects, compared with monotherapy (27).

Adapalene's particle size (diameter between 3 and 10  $\mu\text{m}$ ) and its lipophilic properties result in optimal follicular duct penetration (22); furthermore, after five minutes of exposure, 14-C labeled adapalene applied to human skin in vitro demonstrates radiosensitivity in the pilosebaceous units, with sparse activity in the SC and epidermis (11).

Adverse effects, including erythema, scaling, dryness, pruritis, and burning, occur mainly during the first month and decrease thereafter (11). Nevertheless, in comparative trials, adapalene demonstrates a more favorable side effect profile than its relative, tretinoin. Cyanoacrylate strip data suggests that application of adapalene 0.1% gel every other day may be effective maintenance therapy in microcomedone reduction, resulting in decreased exposure (62).

## AZELAIC ACID

Azelaic acid, a naturally occurring, saturated C9-dicarboxylic acid, modifies epidermal keratinization (cytostatic), combats both aerobic and anaerobic bacteria (reducing *P. acnes* proliferation), and exhibits anti-inflammatory activity (19,63). This anti-inflammatory activity may potentially be mediated through inhibition of hydroxyl and superoxide radical production by neutrophils (64). Contributing to its anti-inflammatory properties, in vitro, azelaic acid is an oxygen free radical scavenger, inhibiting hydroxylation of aromatic compounds and arachidonic acid peroxidation (63,65). To date, no published reports of azelaic acid bacterial resistance have surfaced.

In their review article, Fitton and Goa describe that azelaic acid, in vivo, affects differentiation of human keratinocytes by decreasing synthesis of filaggrin (keratin filament aggregating protein) (65). This results in alterations of epidermal keratinization, including reductions in the number and size of keratohyaline granules and tonofilament bundles in the SC, abnormal tonofilament arrangements, intercellular edema, swollen mitochondria, enlargement of rough endoplasmic reticulum (RER), and reductions in the thickness of the horny layer in infundibular areas (65,66). Azelaic acid functions in a cytostatic, antiproliferative manner on keratinocytes, affecting both early and terminal phases of keratinocyte differentiation, with primary effects on mitochondria and RER (66).

In only two weeks of topical treatment, 200  $\mu\text{L}$  of 20% azelaic acid attenuated tetradecane-induced comedo formation in the rabbit ear, a model of follicular epithelial hyperplasia

(65,67). These microscopic and experimental findings indicate keratolytic and antimicrobogenic properties for azelaic acid via normalization of disordered keratinization of the follicular infundibulum. This is further evidenced by reduction in non-inflammatory acne lesions after topical treatment (see studies in the following text).

Cyanoacrylate skin surface biopsies have demonstrated significant reductions (>50%) in comedo count after four months of twice-daily 20% azelaic acid treatment when compared with vehicle (68). Additionally, comedone reduction was similar in magnitude to that of 0.05% retinoic acid cream (68).

Azelaic acid has demonstrated significant inflammatory and noninflammatory acne reduction in numerous studies, even when compared with tretinoin, BPO, erythromycin, and tetracycline (63,64). Comparing 20% azelaic acid to 0.05% tretinoin over six months, one group found statistically equivalent comedone and total lesion reduction and similar overall improvement (69). However, tretinoin use led to increased erythema, scaling, and irritation-induced discontinuation than did azelaic acid (69). Another trial comparing 20% azelaic acid with 5.0% BPO demonstrated a more rapid initial effect with BPO but similar results for global response and inflammatory lesion reduction by four months (70). Keeping with the theme, azelaic acid demonstrated milder, more transient adverse events than BPO (70). Pooling together results of four trials, Mackrides et al. determined that after six months of treatment, 65% to 85% of patients experienced a  $\geq 50\%$  decrease in number of lesions (good-to-excellent clinical response).

A 12-week controlled study of azelaic acid 20% demonstrated significant improvement in mild-to-moderate acne, compared with its vehicle (69). During the three months, inflammatory lesions decreased by 72%, comedones by 55.6%, and 64% of treated patients had good-to-excellent improvement (69). Symptomatic improvement is typically observed within four weeks of commencing therapy (7).

Transient side effects lasting two to four weeks have been described (63). These include burning, erythema, dryness, scaling, pruritis, and hypopigmentation. Nonetheless, there is some evidence that azelaic acid may improve the overall wearability (feel, smoothness, evenness, and ease of application) of a facial foundation (64).

After application of azelaic acid, 3% to 5% remains on the SC, up to 10% penetrates into the epidermis and dermis, and 4% is absorbed systemically (although, this can double with gel formulations) (7). Nevertheless, baseline serum and urine levels are not altered by topical usage and are primarily dependent on dietary intake of whole grain cereals and animal products (7). It is an FDA Pregnancy Category B drug as animal studies have shown favorable results; meaningful human studies are lacking.

Despite efficacy as a monotherapy, a large randomized trial demonstrated that azelaic acid functions better in combination (64). Subjects were randomized to a 12-week regimen of azelaic acid 20% cream twice daily, either as monotherapy or in combination with one of the following: 4% BPO gel twice daily, 1% clindamycin gel twice daily, 0.025% tretinoin cream once daily, or 3% erythromycin/5% BPO gel twice daily (64). All four regimens improved acne, achieving greater efficacy and patient satisfaction than azelaic acid monotherapy (64). In combination with 3% erythromycin/5% BPO, 20% azelaic acid produced a marked and relatively expedient decrease in inflammatory lesions (64). At the end of 12 weeks, reduction in this group was similar to 20% azelaic acid/1% clindamycin, which was the most tolerable of all regimens (64). In

**Table 40.4** Studies Using Colorimetric Protein Assay to Measure Keratolytic Potential

Authors	Drug	Result
Bashir et al. 2005 (71)	Aqueous solution 2% SA—3 formulations	Statistically significant mass of SC removed after 6 hr and 20 tape strips in all three experimental groups (SA pH 3.3, SA pH 3.3 w/menthol, SA pH 6.95) compared with vehicle, untreated, and untreated but occluded groups.
Waller et al. 2006 (93)	Aqueous solutions of 0.05% all-trans RA, 2% BPO, and 2% SA	Statistically significant mass of SC removed after 6 hr and 25 tape strips in all three experimental groups compared with vehicle, untreated, and occluded groups. The first 10 tape strips from SA group removed more protein than the other groups; at 10 to 15 strips, treatments were comparable; at 16 to 25 strips, protein removed from BP sites was greatest.

Abbreviations: SA, salicylic acid; BPO, benzoyl peroxide; RA, retinoic acid.

noninflammatory lesion treatment, however, azelaic acid with 4% BPO and azelaic acid with 0.025% tretinoin were most effective (64). The azelaic acid plus BPO regimen also achieved the highest patient ratings in overall therapeutic result (64).

## SALICYLIC ACID

A core component in many over-the-counter (OTC) acne treatments, salicylic acid (SA) is a widely available topical keratolytic agent. It may have a profound structural effect on the SC, resulting in disruption of intercorneocyte cohesion and subsequent desquamation (71). Dissolution of intercellular cement is further supported by scanning electron microscopy, which has demonstrated marked squamous cell separation in SA-treated human skin (72). Bashir et al. demonstrated the keratolytic properties of SA using a novel tape stripping/protein assay method described later (Table 40.4). Mills and Kligman using cyanoacrylate follicular biopsy demonstrated significant decreases in microcomedone count. Although various concentrations exist (0.5–10%), 2% is the maximum strength allowed by the FDA in OTC products.

In five human subjects, microcomedo formation was induced via 10% coal tar distillate ointment at four sites on the back; formation was confirmed by cyanoacrylate biopsy (73). At each site, subjects were treated with one of three different concentrations of SA (0.5%, 1%, and 2%), twice daily for two weeks, and one site was left untreated (73). Ultimately, lesions were rebiopsied and examined microscopically; all three concentrations displayed tremendous comedolytic activity, with the 2% preparation superior to the lower concentrations (73). Microcomedo quantitative reduction reached nearly 50% in the 2% SA group (73).

Two 12-week studies comparing 0.5% and 2% SA pads to placebo pads demonstrated significant efficacy in reducing inflammatory acne, noninflammatory acne, and total lesions, while producing significantly higher proportions of good-to-excellent overall treatment assessments (73). In one study, 60% of patients using 2% and 0.5% SA pads experienced a 75% to 100% decrease in total lesion count, compared with 2% of patients receiving placebo (73). In both studies, side effects were minimal and well tolerated (73). In a study comparing medicated pads with 0.5% SA in an alcoholic detergent (Stri-Dex) to placebo (pads soaked in buffered water), the treatment group experienced a 54% reduction in inflammatory acne compared with 29% in the placebo group (74). Reductions of open comedones and total lesions were also significant compared with placebo (74).

A 12-week study found 2% SA cream superior to 5% BPO cream in reducing closed comedones, open comedones, inflam-

matory lesions, and total lesions (73). A four-week crossover study comparing a 2% SA acne cleanser to a 10% BPO wash demonstrated that only patients treated with the SA cleanser had a significant decrease in comedonal lesions (75). Stated differently, both groups demonstrated significant improvement in comedonal count when treated with SA, whereas BPO treatment either worsened or insignificantly improved comedonal quantity (75). A small study comparing a 2% SA/1% clindamycin combination with placebo demonstrated a significant reduction in inflammatory and noninflammatory lesions, with 71% of subjects reporting improvement after eight weeks (compared with 11% of placebo group) (76).

Salicylic acid is well absorbed as evidenced by numerous studies; its bioavailability in topical application varies according to duration of contact (8,77). One study estimated bioavailabilities for topically applied SA at 57.6% and 44.0% for hydroalcoholic and cream delivery vehicles, respectively (78). The same study also demonstrated the hydroalcohol vehicle to have superior peak plasma SA concentrations and earlier time to peak when compared with a cream vehicle (78).

In a related study, absorption was enhanced significantly in a mineral oil/petrolatum ointment compared with an ointment containing polyethylene glycol, glycerol, petrolatum, 10% urea (Kerasal) (79). New chemical peels using 30% SA in polyethylene glycol vehicle have demonstrated efficacy and safety, with marked reductions in comedones and papules (80). Polyethylene glycol may be a more tolerable vehicle than the commonly used ethyl alcohol in SA chemical peels (80).

Although local skin irritation (e.g., peeling) at concentrations greater than 2% is common, systemic toxicity is rare (7). However, if applied to large areas of the body for prolonged periods of time, salicylate toxicity, toxic inner ear damage, and hypersensitivity reactions are plausible (7). To that end, these manifestations are uncommon in appropriate acne therapy. Like several other keratolytic agents, SA is an FDA Pregnancy Category C agent, with unknown effects on breast-feeding.

## SULFUR

Sulfur, a yellow nonmetallic element, has many dermatological indications, including but not limited to acne vulgaris, rosacea, seborrheic dermatitis, and dandruff (81). Once a very common ingredient in acne treatments, sulfur has fallen out of favor, partly due to its pungent odor (82). In the acne arena, sulfur is thought to be keratolytic and bacteriostatic. After application to skin, sulfur reacts with cysteine in the SC, resulting in reduction to hydrogen sulfide (81). Hydrogen sulfide is thought to break down keratin and inhibit growth of *P. acnes* (81).

Appearing in a variety of vehicles (lotions, creams, soaps, ointments), it appears to be more efficacious when used in combination with other drugs, namely BPO and sodium sulfacetamide (7). Clinical trials have demonstrated that lotions containing sulfur 5% with sodium sulfacetamide 10% have resulted in reduction of inflammatory lesions, comedones, and seborrhea (81). Interestingly, this combination is also effective in acne rosacea, an inflammatory skin disorder involving the cheeks, nose, and forehead (81). In clinical trials, sulfur and sulfur/sodium sulfacetamide have demonstrated superiority in reducing overall severity and inflammatory lesion count when compared with metronidazole gel and oral tetracycline (81).

Sulfur penetrates skin; it is detectable in the epidermis at 2 hours, throughout the skin in 8 hours, and completely undetectable by 24 hours (81). Additionally, there is no evidence of systemic absorption in intact skin (81). Early studies, using human and animal subjects, demonstrated that elemental sulfur, while having a positive role in diminishing papules and pustules, may possibly induce comedone formation (81,83). Later studies did not confirm these results despite identical treatment conditions (81,84). Rare, transient side effects include dryness, itching, and malodorous skin. Nonetheless, given a lack of knowledge, it is an FDA Pregnancy Class C drug with nothing known regarding breast milk excretion.

## GLYCOLIC ACID

Glycolic acid, a naturally occurring organic acid ( $\alpha$ -hydroxy acid), is a component in many cosmetic formulations. In the context of acne, research has been conducted examining glycolic acid chemical peels. Superficial chemical peels may serve as valuable adjuvant therapy in acne. Various chemical preparations have been employed, all of which result in a partial-thickness skin injury, or peel (85). Comedones are removed after only two or three peels, and the procedure may be repeated every two or three weeks (86). Between peels, low concentrations of glycolic acid may be used as a daily cleanser to prevent reocclusion of follicles (86).

Glycolic acid, a hydrophilic compound with keratolytic properties, is present in many peel formulations due to its desquamating efficacy. According to Kessler et al., "this desquamation reduces corneocyte cohesion, keratinocyte plugging, and enables the extrusion of inflammatory contents."

Glycolic acid mainly effects deeper, newly forming levels of SC, leading to a sheet-like separation (87). The exact mechanism of action may be due to inhibition of ionic bond forming enzymes involved in creating sulfated and phosphorylated mucopolysaccharides, glycoproteins, sterols, and lipid phosphatides (87). This results in fewer electronegative groups on the outer walls of keratinocytes and corneocytes, effectively diminishing cohesion forces (87). This diminished cohesion loosens keratinocytes in the follicular epithelium, resulting in breakdown of comedones, inhibition of comedone formation, and unroofing of pustules (86).

A randomized split-face prospective clinical trial comparing glycolic acid to Jessner's solution (salicylic acid, lactic acid, and resorcinol) demonstrated significant acne improvement in both after three treatment sessions. Furthermore, glycolic acid was associated with significantly less exfoliation than Jessner's solution, resulting in more facile makeup application, and suggesting a more favorable side effect profile (88). In a similar study comparing glycolic acid and SA peels, both were equally effective by the second treatment; however, SA demonstrated

greater sustained effectiveness and a more favorable side effect profile (85). A study examining 35% and 50% glycolic acid peels on Asian patients found significant resolution of comedones, papules, and pustules; decrease in follicular pore size; improvement in acne scarring; and few side effects (89).

A combination of azelaic acid 20% cream and glycolic acid lotion was compared with tretinoin 0.025% in a 12-week, vehicle-controlled study (28). The azelaic acid-glycolic acid treatment produced significantly greater inflammatory lesion reduction and equivalent noninflammatory lesion reduction, while causing less dryness, scaling, and erythema than tretinoin (28).

## RESORCINOL

Because of limited information about resorcinol, all of the following information was extracted from a review article by Karam in 1993 (90). No longer significantly used in the United States, resorcinol, an isomer of hydroquinone and a relative of phenol, is soluble in water, ether, and alcohol. It is a reducing agent with antibacterial and keratolytic properties. Even at low concentrations, it can disrupt hydrogen bonds of keratin. A 50% resorcinol paste, consisting of a benzoinated axungia vehicle and two drying agents, zinc oxide and ceyssatite, is used in other countries for chemical peels.

It is used to treat the postinflammatory hyperpigmentation, erythema, and shallow scars resulting from facial, chest, upper back, and buttocks acne. One facial peel, typically 30 minutes in duration, may be sufficient for treatment. Additional peels can be done a few hours to two days later. Patients typically receive pretreatment with 0.05% retinoic acid cream for a period of two weeks to three months before the facial peel. This pretreatment may help assist in resorcinol absorption, resulting in a deeper peel. In addition to acne, resorcinol peels can be used to treat melasma, sun-damaged skin, and freckling.

Contraindications include pregnancy and skin type VI, due to inadequate data regarding complications. Acne surgery prior to the peel is recommended to prevent aggravation of deep comedones and subsequent pustular development. Side effects include burning sensation and paresthesia, which can be felt anywhere from 2 to 30 minutes after application. Burning intensity increases initially, stopping after one hour; despite discomfort, pain is usually tolerable. Additionally, subsequent resorcinol applications cause more intense burning sensation, prompting shorter exposure. Corticoid creams and cold compresses may provide some relief. Dizziness immediately after the peel may last 10 to 15 minutes and is probably secondary to flushing related to resorcinol application.

Histologically, shortly after resorcinol application, splitting occurs at the granular cell layer along with vasodilatation. One week later, prominent basal cell layer mitosis, fibroblast proliferation, vasodilatation, and formation of a thickened dermal band are visible. Although the vasodilation resolves, the other changes are present even four months later.

## IN VIVO KERATOLYTIC POTENTIAL OF BENZOYL PEROXIDE, RETINOIC ACID, AND SALICYLIC ACID

The SC desquamating effect of three keratolytics is presented in table format (Table 40.4) using data obtained from colorimetric protein assays described by Dreher et al. in 1998 (71,91-93).

These in vivo human results indicate that all three treatments tested are effective keratolytics, which may account, to some degree, for their effectiveness against acne vulgaris.



Furthermore, on the basis of the stratified analysis of tape stripping, it appears that SA may be more optimal in treating mild, superficial acne, while BPO may be better suited for deeper, inflammatory acne conditions. BPO's ability to loosen SC at deeper levels complements its antimicrobial properties, resulting in an effective anti-inflammatory agent for papulopustular acne. Additionally, it appears that BPO appears to be effective even with short-term administration. RA had inferior SC disruption at three hours but significant disruption at six hours, indicating time-dependent keratolytic effects, consistent with its well-studied interaction with nuclear receptors and alteration of gene transcription.

## CONCLUSION

Taken together, a century of clinical trials and clinical use support the efficacy of keratolytics in acne. We suspect that the near future will provide more rapid advances, based on the power and ease of interpretation of the newly devised in vivo human keratolytic assay.

## REFERENCES

1. Lavker RM, Leyden JJ, Thorne EG. An ultrastructural study of the effects of topical tretinoin on microcomedones. *Clin Ther* 1992; 14(6): 773-780.
2. Hatakeyama S, Hayashi S, Yoshida Y, et al. Retinoic acid disintegrated desmosomes and hemidesmosomes in stratified oral keratinocytes. *J Oral Pathol Med* 2004; 33(10):622-628.
3. Habif TP. *Skin Disease: Diagnosis and Treatment*. 2nd ed. Philadelphia: Elsevier Mosby, 2006.
4. Russell JJ. Topical therapy for acne. *Am Fam Phys* 2000; 61(2): 357-366.
5. Warner GT, Plosker GL. Clindamycin/benzoyl peroxide gel: a review of its use in the management of acne. *Am J Clin Dermatol* 2002; 3(5):349-360.
6. Worret WJ, Fluhr JW. [Acne therapy with topical benzoyl peroxide, antibiotics and azelaic acid]. *J Dtsch Dermatol Ges* 2006; 4(4): 293-300.
7. Akhavan A, Bershad S. Topical acne drugs: review of clinical properties, systemic exposure, and safety. *Am J Clin Dermatol* 2003; 4(7):473-492.
8. Feldmann RJ, Maibach HI. Absorption of some organic compounds through the skin in man. *J Invest Dermatol* 1970; 54(5): 399-404.
9. Degitz K, Ochsendorf F. Pharmacotherapy of acne. *Expert Opin Pharmacother* 2008; 9(6):955-971.
10. Fyrand O, Jakobsen HB. Water-based versus alcohol-based benzoyl peroxide preparations in the treatment of acne vulgaris. *Dermatologica* 1986; 172(5):263-267.
11. Shroot B. Pharmacodynamics and pharmacokinetics of topical adapalene. *J Am Acad Dermatol* 1998; 39(2 pt 3):S17-S24.
12. Mills OH Jr., Kligman AM, Pochi P, et al. Comparing 2.5%, 5%, and 10% benzoyl peroxide on inflammatory acne vulgaris. *Int J Dermatol* 1986; 25(10):664-667.
13. Prince RA, Harris JM, Maroc JA. Comparative trial of benzoyl peroxide versus benzoyl peroxide with urea in inflammatory acne. *Cutis* 1982; 29(6):638-640, 644-645.
14. Lookingbill DP, Chalker DK, Lindholm JS, et al. Treatment of acne with a combination clindamycin/benzoyl peroxide gel compared with clindamycin gel, benzoyl peroxide gel and vehicle gel: combined results of two double-blind investigations. *J Am Acad Dermatol* 1997; 37(4):590-595.
15. Leyden JJ, Hickman JG, Jarratt MT, et al. The efficacy and safety of a combination benzoyl peroxide/clindamycin topical gel compared with benzoyl peroxide alone and a benzoyl peroxide/erythromycin combination product. *J Cutan Med Surg* 2001; 5(1): 37-42.
16. Breneman D, Savin R, VandePol C, et al. Double-blind, randomized, vehicle-controlled clinical trial of once-daily benzoyl peroxide/clindamycin topical gel in the treatment of patients with moderate to severe rosacea. *Int J Dermatol* 2004; 43(5):381-387.
17. Basak PY, Gultekin F, Kilinc I, et al. The effect of benzoyl peroxide and benzoyl peroxide/erythromycin combination on the antioxidative defence system in papulopustular acne. *Eur J Dermatol* 2002; 12(1):53-57.
18. Leyden JJ. A review of the use of combination therapies for the treatment of acne vulgaris. *J Am Acad Dermatol* 2003; 49(3 suppl): S200-S210.
19. Krautheim A, Gollnick HP. Acne: topical treatment. *Clin Dermatol* 2004; 22(5):398-407.
20. Shalita AR, Chalker DK, Griffith RF, et al. Tazarotene gel is safe and effective in the treatment of acne vulgaris: a multicenter, double-blind, vehicle-controlled study. *Cutis* 1999; 63(6):349-354.
21. Kang S. The mechanism of action of topical retinoids. *Cutis* 2005; 75(2 suppl):10-13; discussion 13.
22. Bikowski JB. Mechanisms of the comedolytic and anti-inflammatory properties of topical retinoids. *J Drugs Dermatol* 2005; 4(1): 41-47.
23. Chivot M. Retinoid therapy for acne. A comparative review. *Am J Clin Dermatol* 2005; 6(1):13-19.
24. Marcelo CL, Madison KC. Regulation of the expression of epidermal keratinocyte proliferation and differentiation by vitamin A analogs. *Arch Dermatol Res* 1984; 276(6):381-389.
25. Leyden JJ, Shalita A, Thiboutot D, et al. Topical retinoids in inflammatory acne: a retrospective, investigator-blinded, vehicle-controlled, photographic assessment. *Clin Ther* 2005; 27(2):216-224.
26. Berger R, Barba A, Fleischer A, et al. A double-blinded, randomized, vehicle-controlled, multicenter, parallel-group study to assess the safety and efficacy of tretinoin gel microsphere 0.04% in the treatment of acne vulgaris in adults. *Cutis* 2007; 80(2):152-157.
27. Thiboutot DM, Weiss J, Bucko A, et al. Adapalene-benzoyl peroxide, a fixed-dose combination for the treatment of acne vulgaris: results of a multicenter, randomized double-blind, controlled study. *J Am Acad Dermatol* 2007; 57(5):791-799.
28. Spellman MC, Pincus SH. Efficacy and safety of azelaic acid and glycolic acid combination therapy compared with tretinoin therapy for acne. *Clin Ther* 1998; 20(4):711-721.
29. Lammer EJ, Flannery DB, Barr M. Does isotretinoin cause limb reduction defects? *Lancet* 1985; 2(8450):328.
30. Lipson AH, Collins F, Webster WS. Multiple congenital defects associated with maternal use of topical tretinoin. *Lancet* 1993; 341(8856):1352-1353.
31. Camera G, Pregliasco P. Ear malformation in baby born to mother using tretinoin cream. *Lancet* 1992; 339(8794):687.
32. Jick SS, Terris BZ, Jick H. First trimester topical tretinoin and congenital disorders. *Lancet* 1993; 341(8854):1181-1182.
33. Mills OH Jr., Kligman AM. Assay of comedolytic activity in acne patients. *Acta Derm Venereol* 1983; 63(1):68-71.
34. Lucky AW, Cullen SI, Jarratt MT, et al. Comparative efficacy and safety of two 0.025% tretinoin gels: results from a multicenter double-blind, parallel study. *J Am Acad Dermatol* 1998; 38(4):S17-S23.
35. Skov MJ, Quigley JW, Bucks DA. Topical delivery system for tretinoin: research and clinical implications. *J Pharm Sci* 1997; 86(10):1138-1143.
36. Nyirady J, Nighland M, Payonk G, et al. A comparative evaluation of tretinoin gel microsphere, 0.1%, versus tretinoin cream, 0.025%, in reducing facial shine. *Cutis* 2000; 66(2):153-156.
37. Leyden JJ, Krochmal L, Yaroshinsky A. Two randomized, double-blind, controlled trials of 2219 subjects to compare the combination clindamycin/tretinoin hydrogel with each agent alone and vehicle for the treatment of acne vulgaris. *J Am Acad Dermatol* 2006; 54(1):73-81.
38. Shalita AR, Rafal ES, Anderson DN, et al. Compared efficacy and safety of tretinoin 0.1% microsphere gel alone and in combination

- with benzoyl peroxide 6% cleanser for the treatment of acne vulgaris. *Cutis* 2003; 72(2):167-172.
39. Laquieze S, Czernielewski J, Rueda MJ. Beneficial effect of a moisturizing cream as adjunctive treatment to oral isotretinoin or topical tretinoin in the management of acne. *J Drugs Dermatol* 2006; 5(10):985-990.
  40. Gollnick H, Cunliffe W, Berson D, et al. Management of acne: a report from a global alliance to improve outcomes in acne. *J Am Acad Dermatol* 2003; 49(1 suppl):S1-37.
  41. Cunliffe WJ, Norris JF. Isotretinoin—an explanation for its long-term benefit. *Dermatologica* 1987; 175(suppl 1):133-137.
  42. Strauss JS, Leyden JJ, Lucky AW, et al. Safety of a new micronized formulation of isotretinoin in patients with severe recalcitrant nodular acne: a randomized trial comparing micronized isotretinoin with standard isotretinoin. *J Am Acad Dermatol* 2001; 45(2):196-207.
  43. Chalker DK, Leshner JL Jr., Smith JG Jr., et al. Efficacy of topical isotretinoin 0.05% gel in acne vulgaris: results of a multicenter, double-blind investigation. *J Am Acad Dermatol* 1987; 17(2 pt 1):251-254.
  44. Akman A, Durusoy C, Senturk M, et al. Treatment of acne with intermittent and conventional isotretinoin: a randomized, controlled multicenter study. *Arch Dermatol Res* 2007; 299(10):467-473.
  45. Berard A, Azoulay L, Koren G, et al. Isotretinoin, pregnancies, abortions and birth defects: a population-based perspective. *Br J Clin Pharmacol* 2007; 63(2):196-205.
  46. Taibjee SM, Charles-Holmes R. Pitfalls of prescribing acne therapies including isotretinoin for pilots. *Br J Dermatol* 2008; 158(3):653-655.
  47. Wysowski DK, Pitts M, Beitz J. An analysis of reports of depression and suicide in patients treated with isotretinoin. *J Am Acad Dermatol* 2001; 45(4):515-519.
  48. Hull PR, D'Arcy C. Isotretinoin use and subsequent depression and suicide: presenting the evidence. *Am J Clin Dermatol* 2003; 4(7):493-505.
  49. Cohen J, Adams S, Patten S. No association found between patients receiving isotretinoin for acne and the development of depression in a Canadian prospective cohort. *Can J Clin Pharmacol* 2007; 14(2):e227-e233.
  50. Jick SS, Kremers HM, Vasilakis-Scaramozza C. Isotretinoin use and risk of depression, psychotic symptoms, suicide, and attempted suicide. *Arch Dermatol* 2000; 136(10):1231-1236.
  51. Rubinow DR, Peck GL, Squillace KM, et al. Reduced anxiety and depression in cystic acne patients after successful treatment with oral isotretinoin. *J Am Acad Dermatol* 1987; 17(1):25-32.
  52. Georgala S, Papassotiriou I, Georgala C, et al. Isotretinoin therapy induces DNA oxidative damage. *Clin Chem Lab Med* 2005; 43(11):1178-1182.
  53. Chandraratna RA. Tazarotene: the first receptor-selective topical retinoid for the treatment of psoriasis. *J Am Acad Dermatol* 1997; 37(2 pt 3):S12-S17.
  54. Shalita A, Miller B, Menter A, et al. Tazarotene cream versus adapalene cream in the treatment of facial acne vulgaris: a multicenter, double-blind, randomized, parallel-group study. *J Drugs Dermatol* 2005; 4(2):153-158.
  55. Bershad S, Kranjac Singer G, Parente JE, et al. Successful treatment of acne vulgaris using a new method: results of a randomized vehicle-controlled trial of short-contact therapy with 0.1% tazarotene gel. *Arch Dermatol* 2002; 138(4):481-489.
  56. Tangheiti E, Abramovits W, Solomon B, et al. Tazarotene versus tazarotene plus clindamycin/benzoyl peroxide in the treatment of acne vulgaris: a multicenter, double-blind, randomized parallel-group trial. *J Drugs Dermatol* 2006; 5(3):256-261.
  57. Thiboutot D, Pariser DM, Egan N, et al. Adapalene gel 0.3% for the treatment of acne vulgaris: a multicenter, randomized, double-blind, controlled, phase III trial. *J Am Acad Dermatol* 2006; 54(2):242-250.
  58. Cunliffe WJ, Poncet M, Loesche C, et al. A comparison of the efficacy and tolerability of adapalene 0.1% gel versus tretinoin 0.025% gel in patients with acne vulgaris: a meta-analysis of five randomized trials. *Br J Dermatol* 1998; 139(suppl 52):48-56.
  59. Martin B, Meunier C, Montels D, et al. Chemical stability of adapalene and tretinoin when combined with benzoyl peroxide in presence and in absence of visible light and ultraviolet radiation. *Br J Dermatol* 1998; 139(suppl 52):8-11.
  60. Galvin SA, Gilbert R, Baker M, et al. Comparative tolerance of adapalene 0.1% gel and six different tretinoin formulations. *Br J Dermatol* 1998; 139(suppl 52):34-40.
  61. Korkut C, Piskin S. Benzoyl peroxide, adapalene, and their combination in the treatment of acne vulgaris. *J Dermatol* 2005; 32(3):169-173.
  62. Thielitz A, Sidou F, Gollnick H. Control of microcomedone formation throughout a maintenance treatment with adapalene gel, 0.1%. *J Eur Acad Dermatol Venereol* 2007; 21(6):747-753.
  63. Mackrides PS, Shaughnessy AF. Azelaic acid therapy for acne. *Am Fam Physician* 1996; 54(8):2457-2459.
  64. Webster, G., Combination azelaic acid therapy for acne vulgaris. *J Am Acad Dermatol* 2000; 43(2 pt 3):S47-S50.
  65. Fitton A, Goa KL. Azelaic acid. A review of its pharmacological properties and therapeutic efficacy in acne and hyperpigmentary skin disorders. *Drugs* 1991; 41(5):780-798.
  66. Mayer-da-Silva A, Gollnick H, Detmar M, et al. Effects of azelaic acid on sebaceous gland, sebum excretion rate and keratinization pattern in human skin. An in vivo and in vitro study. *Acta Derm Venereol Suppl (Stockh)* 1989; 143:20-30.
  67. Topert M, Rach P, Siegmund F. Pharmacology and toxicology of azelaic acid. *Acta Derm Venereol Suppl (Stockh)* 1989; 143:14-19.
  68. Barbareschi M, Hendricks I, Angius A, et al. The anticomedonic activity of azelaic acid investigated by means of scanning electron microscopy on horny layer biopsy. *J Dermatol Treat* 1991; (2):55-57.
  69. Katsambas A, Graupe K, Stratigos J. Clinical studies of 20% azelaic acid cream in the treatment of acne vulgaris. Comparison with vehicle and topical tretinoin. *Acta Derm Venereol Suppl (Stockh)* 1989; 143:35-39.
  70. Cavicchini S, Caputo R. Long-term treatment of acne with 20% azelaic acid cream. *Acta Derm Venereol Suppl (Stockh)* 1989; 143:40-44.
  71. Bashir SJ, Dreher F, Chew AL, et al. Cutaneous bioassay of salicylic acid as a keratolytic. *Int J Pharm* 2005; 292(1-2):187-194.
  72. Davies M, Marks R. Studies on the effect of salicylic acid on normal skin. *Br J Dermatol* 1976; 95(2):187-192.
  73. Zander E, Weisman S. Treatment of acne vulgaris with salicylic acid pads. *Clin Ther* 1992; 14(2):247-253.
  74. Shalita AR. Treatment of mild and moderate acne vulgaris with salicylic acid in an alcohol-detergent vehicle. *Cutis* 1981; 28(5):556-558, 561.
  75. Shalita AR. Comparison of a salicylic acid cleanser and a benzoyl peroxide wash in the treatment of acne vulgaris. *Clin Ther* 1989; 11(2):264-267.
  76. Touitou E, Godin B, Shumilov M, et al. Efficacy and tolerability of clindamycin phosphate and salicylic acid gel in the treatment of mild to moderate acne vulgaris. *J Eur Acad Dermatol Venereol* 2008; 22(5):629-631.
  77. Rougier A, Dupuis D, Lotte C, et al. The measurement of the stratum corneum reservoir. A predictive method for in vivo percutaneous absorption studies: influence of application time. *J Invest Dermatol* 1985; 84(1):66-68.
  78. Davis DA, Kraus AL, Thompson GA, et al. Percutaneous absorption of salicylic acid after repeated (14-day) in vivo administration to normal, acnegenic or aged human skin. *J Pharm Sci* 1997; 86(8):896-899.
  79. Schwarb FP, Gabard B, Rufli T, et al. Percutaneous absorption of salicylic acid in man after topical administration of three different formulations. *Dermatology* 1999; 198(1):44-51.
  80. Dainichi T, Ueda S, Imayama S, et al. Excellent clinical results with a new preparation for chemical peeling in acne: 30% salicylic acid in polyethylene glycol vehicle. *Dermatol Surg* 2008; 34(7):891-899.
  81. Gupta AK, Nicol K. The use of sulfur in dermatology. *J Drugs Dermatol* 2004; 3(4):427-431.

82. Kaminsky A. Less common methods to treat acne. *Dermatology* 2003; 206(1):68–73.
83. Mills OH Jr., Kligman AM. Is sulphur helpful or harmful in acne vulgaris? *Br J Dermatol* 1972; 86(6):620–627.
84. Strauss JS, Goldman PH, Nacht S, et al. A reexamination of the potential comedogenicity of sulfur. *Arch Dermatol* 1978; 114(9): 1340–1342.
85. Kessler E, Flanagan K, Chia C, et al. Comparison of alpha- and beta-hydroxy acid chemical peels in the treatment of mild to moderately severe facial acne vulgaris. *Dermatol Surg* 2008; 34(1): 45–50; discussion 51.
86. Kneedler JA, Sky SS, Sexton LR. Understanding alpha-hydroxy acids. *Dermatol Nurs* 1998; 10(4):247–254, 259–262; quiz 265–266.
87. Van Scott EJ, Yu RJ. Hyperkeratinization, corneocyte cohesion, and alpha hydroxy acids. *J Am Acad Dermatol* 1984; 11(5 pt 1): 867–879.
88. Kim SW, Moon SE, Kim JA, et al. Glycolic acid versus Jessner's solution: which is better for facial acne patients? A randomized prospective clinical trial of split-face model therapy. *Dermatol Surg* 1999; 25(4):270–273.
89. Wang CM, Huang CL, Hu CT, et al. The effect of glycolic acid on the treatment of acne in Asian skin. *Dermatol Surg* 1997; 23(1):23–29.
90. Karam PG. 50% Resorcinol peel. *Int J Dermatol* 1993; 32(8):569–574.
91. Dreher F, Arens A, Hostý'nek JJ, et al. Colorimetric method for quantifying human Stratum corneum removed by adhesive-tape stripping. *Acta Derm Venereol* 1998; 78(3):186–189.
92. Leveque N, Makki S, Hadgraft J, et al. Comparison of Franz cells and microdialysis for assessing salicylic acid penetration through human skin. *Int J Pharm* 2004; 269(2):323–328.
93. Waller JM, Dreher F, Behnam S, et al. "Keratolytic" properties of benzoyl peroxide and retinoic acid resemble salicylic acid in man. *Skin Pharmacol Physiol* 2006; 19(5):283–289.

## Cosmetics for men

Robert Baran and Annick Pons-Guiraud

### INTRODUCTION

Cosmetic needs develop in cycles according to different cultures. They are at present far more limited in the male population than in the female. Dermatologists have now observed a change in male attitudes toward cosmetology and commonly attribute that change to the combined influences of advertising, the introduction of new ranges of cosmetic products for men, and the influence of women. Men are taking more care of their appearance. They have been conditioned to do so gradually by the availability of a range of products directed toward men only and presented with a masculine orientation. The correct terminology would now appear to be *care* rather than *beauty* as the male market gradually enters the female domain, and male consumers, rather than their wives, become the target of these products. The potential market comprises virtually all males over the age of 14. Shaving products and hair lotions usually represent a consumer's first contact with men's toiletries. Aftershave balms, emulsions and gels, eau de toilette and eau de cologne are likely to be the products most often sold in specialized departments. Deodorants, bath preparations and shower gels are also popular. On the basis of a survey by Frost and Sullivan (1), nearly half of the masculine grooming business consists of toilet soap (63% of sales are deodorant soaps, 25% are purifying soaps, and the rest are specific products). Fitness, freshness, naturalness and, in particular, care are today's key terms for conveying the product message.

Cosmetics for men and women have traditionally been formulated differently. Products for men are usually characterized by the presence of alcohol, which has rarely been used in cosmetics for women. The appeal to the two groups is also distinct, with men seeking well-being and health and women pursuing health and beauty. Men treat their skin in response to a need, such as shaving, cleansing, and treating cuts and nicks. They are less prone to viewing skin care as an aging prevention or appearance-enhancing practice. Analysts report, however, that this attitude is changing. Some men, they say, are already dipping into their partners' skin care products. Some men do worry about aging (e.g., aging spots) probably to present an image compatible with their profession. That view is supported by the increasing number of men who seek cosmetic plastic surgery. Moreover, men ask for discreet products labeled "For Men," which appeal to their virility.

Skin physiology shows differences between women and men (see chap. 2) (2). The influence of age and sex on skin thickness, skin collagen and density has been studied by Shuster et al. (3).

### SKIN THICKNESS

The thickness of the skin varies depending on site, age and sex. Androgen stimulation causes increase in the thickness of the skin and this is generally more important in the man than in the woman (4-6). Male skin is approximately 25% thicker than that of women. It increases the resistance of the male skin.

There is a gradual, but highly significant, thinning of male skin with increasing age. In female skin, however, thickness remains surprisingly constant until the fifth decade, after which there is also a significant thinning with increasing age. At the same age and following the same weathering conditions, wrinkles are more pronounced in male than in female skin.

Concerning dermal-epidermal junction, the lamina densa is thinner in the female (7). But there appears to be no difference in the lamina lucida.

In adult skin, the clinical features of aging are closely related to the total collagen content. The relationship of skin collagen to sex is obvious. There is a linear decrease in skin collagen with increasing age, and male forearm skin contains more collagen than female skin at the same site at all ages, but the rate of decrease is the same in both sexes, at 1% per year throughout adult life. Collagen density calculated as the ratio of skin collagen to thickness, is very significantly related to age in both males and females, but the density is consistently lower in females at all ages. Lower initial skin collagen content is therefore the reason women appear to age earlier than men. The packing of fibrils in the dermis is also influenced by age and sex. With increasing age, skin collagen decreases more rapidly than skin thickness, resulting in reduced collagen density. Skin collagen is packed less densely in females than males possibly because of the influence of androgen, since collagen density is increased in patients with primary cutaneous virilism. As far as their skin is concerned, women are about 15 years older than men of the same age throughout their adult life.

Recently, Humbert (8) using echographic  $\beta$  scans obtained similar results in noninvasive investigation of the facial skin.

### AGEING OF THE SKIN

The cutaneous ageing is slower in the man but it is often more evident because of deep wrinkles and greater degree of exposure.

Ageing interferes with the hair cycle that varies with age and sex. Concerning the nails, the metabolism of the nail plate lipids varies with age and sex, demonstrating the effects of the sexual hormones (9). The age-dependant decrease in cholesterol sulfate lends might explain the previously observed higher incidence of brittle nails in women (10). Men have a

more rapid rate than women until the sixth decade, by the eighth decade women have a more rapid rate than men (11).

Lastly, hair care differs greatly between the sexes. Men and women do not maintain the same standard of hair care—apparently because of psychological differences.

### GENERAL ASPECT OF THE SKIN

The general aspect of the skin of a man is different from that of a woman. The texture is rougher and the stratum corneum thicker. There is a difference in the composition of the sebum. In males over 10, and females over 15 with no present or past acne, sebum excretion (primarily simulated by androgens) increases until the third or fourth decade, and then decreases, the rate of decrease being similar in both sexes (12).

After puberty, sebum production is significantly greater throughout life in males than in females (12). Greater sebum production results in more severe and long-lasting acne in men. They present dilated pores, sometimes with blackheads. The cells in the male sebaceous glands have a much higher number of positive receptors to androgens. Interestingly, rhinophyma is a condition restricted to men.

Puberty also brings about the appearance of facial hair on men, which becomes the focus of their grooming habits.

There are differences in sweat secretion between the sexes. Men have fewer eccrine and apocrine sweat glands. Pubertal sweating is more pronounced on the hands and feet of girls than boys. Male eccrine sudoral secretion is more acid than female. There is a greater proportion of lactic acid in the male sweat content which accounts for the difference in pH. Its pH is about 0.5 lower. Moreover, the rate of sweating in men is more than double that in women (13). Male eccrine secretion is much greater when stimulated by cholinergic agents or thermogenically although the difference seen in young adults is attenuated with age. The difference between male and female eccrine secretion is an effect of irreversible gene expression due to androgen at puberty and not to androgen modulation in adult life. The result is that a man's skin needs more rehydrating than a woman's. The lack of protection against weathering by creams and makeup accentuates these physiological differences, which are further aggravated by shaving and micro-traumas. The differences between male and female skin becomes especially evident with the onset of puberty. Increased production of androgen is responsible for many of the differences. Transcutaneous measurements of the partial pressure of oxygen show daily variations of as much as 10% in any given individual. There is progressive decline in these figures in both sexes with age. In the male the readings are uniformly less.

The male skin appears to be better hydrated than that of the female. Humbert has shown that the male skin has greater elasticity (8,14).

The male skin is slightly darker possibly because of its greater vascularity in the microcirculation in the skin demonstrated by videocapillaroscopy over the cheekbones in the male (8). Cooke attributes this to central control rather than local mechanism (15).

There are other factors, however, such as a greater degree of exposure to the sun and increase concentration of melanin, carotene and of hemoglobin as a result of the increase blood supply.

### ADIPOSE TISSUE

The distribution of subcutaneous adipose tissue may be regarded as a secondary sexual characteristic. There are intrinsic gender differences in the regulation of P450 aromatase, suggesting that differential enzyme regulation may affect sex steroid metabolism to alter the pattern of fat distribution between the sexes (16). In the male it shows a predisposition for the thorax and abdomen whereas in the female there is a predilection for the hips and thighs. The difference in the arrangement of the adipose tissue between the sexes results in the greater predisposition of women for "peau d'orange." The connection of the skin to the underlying tissue in the male and the oblique arrangement of the fat lobules (17,18) renders the male less vulnerable to this condition.

### COSMETIC NEEDS

Product prescriptions should respond to masculine needs according to the use, if not the range, of specific preparation. The texture of the product should be light. Creams should be rapidly absorbed. The product should be invisible and not stain. Men's products are more pH neutral, since their skin is naturally more acid. Men want easy to use products that are nongreasy, easy to spread, and only lightly perfumed. Beauty masks and other care products requiring time and patience for application are not popular. Shaving creams containing soap and detergents remove lipids. Shaving itself adds to this process by removing the top layers of skin cells. Finally, lipid removal is further compounded by the use of high-alcohol content aftershave lotions, which dissolve even more lipids. Skin cells also become temporarily overhydrated because of the action of detergents and hot water during shaving. The cells later lose water since they are depleted of the lipids that help them retain moisture, and the result can be dry, flaky cells and dull-looking skin. As a result, an uncomfortable tight-skin feeling frequently develops as the outer cells shrink owing to the water loss, becoming, in turn, more sensitive to the irritant effects of sweating, sebum and the environment. Regular shaving also causes ingrown beard hairs in some men's skin.

There are several types of products providing cosmetic needs: (i) alcoholic perfumery, (ii) shaving products, (iii) hair products, (iv) washing products, (v) antiperspirants and deodorants, (vi) depilatories, (vii) products for the sun, and (viii) beauty products.

### TOILET WATER AND EAU DE COLOGNE

Several motives may play a role in the purchase and use of eau de cologne and shaving lotions by men; creating a personal identity, communicating with others, projecting an appearance of freshness and well-being, and looking neat and self-assured.

### SHAVING PRODUCTS

Above all, masculine needs are concentrated on shaving. The importance of the beard is closely linked to a number of psychological factors. The beard has a sexual element, which develops with puberty. The first shave is one of the most important initiation rites whereby a boy becomes a man. Psychological states as diverse as nervous tension, anxiety and overwork can accelerate beard growth. Alcohol abuse can

noticeably slow beard growth. Since the beard grows 2 mm a day, shaving is a daily necessity. It has been said that men spend six months of their lives shaving. Shaving repeatedly injures the skin of the face and neck. It imposes a constant stress on male skin. The outer layers of the stratum corneum are removed by force before the cells are ready to desquamate spontaneously. This forced exfoliation induces an accelerated cell turnover (more than 35%) and exposes skin cells that have not yet been programmed to withstand the effects of the environment. The process of scraping with the razor also results in minute scratches to the outermost layer of the skin. Therefore shaving preparations are a logical answer to a man's main problem.

### Preshaving Products

The most important component in shaving (electric or manual) is the preparation of the skin and beard. The more the beard has been treated before being attacked by the blade, the easier it will be for the razor to slide over the skin. The aim of wet shaving is to soften and engorge the beard with water so that the hairs offer the least possible resistance to cutting, thus avoiding trauma to the skin. The shaving products contain soaps, syndets and lubricants. Washing with hot water and soap before applying a shaving preparation makes wet shaving much easier. Gillet Mach 4 is said to be the first and only shaving system with three progressively aligned blades that provide men with a closer shave in fewer strokes with less irritation. Protector D Metal Razors have an enlarged aquaglide strip and allows maximum control thanks to its rubber grip handle. In the case of shaving with an electric razor, stiffness and hardening of the beard is favored, along with drying and degreasing of the skin. To minimize the risk of irritation, the addition of lipids is indispensable, and the amount of alcohol in the preshave lotion is generally greater than in aftershave lotions. Astringents are added to stiffen the beard. Some brands of electric razors allow to use them even on wet skin. In 1998, Philips brought the benefits of wet shaving to an electric shaver. This dispenses a moisturizing shaving emulsion allowing "a true wet shave experience without the risk of nicks and cuts and, at the same time, an unexpectedly close shave" (19).

### Special Shaving Products

Soaps for the beard are not washing soaps. They are more greasy and characterized by a more absorbent, long-lasting, nondrying compact foam. Shaving creams, sometimes called brushless, are especially adapted to dry and sensitive skin, since they provide a better lubricating action than foams. Foaming shaving creams are very soapy emulsions, consisting of 40% to 50% fatty acids. Erosol shaving creams employ soaps that are very soluble in water to maintain their effectiveness at low temperatures.

### Aftershave Products

The use of an aftershave lotion and a warm towel removes all traces of cream and relaxes the skin. Lotions have generally replaced the shaving block, the hemostatic pencil and vinegar bar, however, some skins are easily cut during shaving, so the use of styptics (alum, aluminum sulfate) is entirely appropriate.

Lotions close the pores of the skin, which have been opened by hot water, relieve the burning sensation, stop bleeding from cuts and subtly perfume the skin. In theory, these alcohol-containing lotions should fight infections in cuts caused by the razor blade. The alcohol content is calculated to minimize any sensation of burning. No feeling of discomfort should remain after shaving.

After shaving, blue reflectors and mirror spheres work to neutralize redness. The products immediately counteract redness of the skin.

## PATHOLOGICAL SKIN PROBLEMS RELATED TO BEARD

Shaving with razor blades increases the risk of perfume contact allergy in men (20), probably because the fragranced lotion is a "leave-on" product.

The five o'clock shadow observed in heavy dark beards, especially after early shaving, is a nonpathological inconvenience, and should be differentiated from excess skin pigmentation resulting from irritation due to shaving too closely and to a photoreaction caused by the perfume. Transparent facial powder dusted over the entire face is useful to lighten the dark areas (21).

Existing skin problems may be worsened under beards, but the most common complaint in shaving is bacterial infection of the beard area (barber's itch) (22), usually following an injury to the skin (with any type of razor) or by pseudofolliculitis.

Folliculitis is most often due to staphylococcal infection involving the hair follicle.

Sycosis barbae most often refers to a superficial follicular involvement of the beard area as pustules or papules.

Antimicrobial soaps are effective in reducing the number of bacteria. With antimicrobial topical agents such as fusidic acid and mupirocine, the need for systemic antibiotics is greatly reduced.

Pseudofolliculitis is a common inflammatory disorder of the follicles, most commonly occurring when tightly coiled or very curly hair is closely shaved and the tips of shaved hairs penetrate the follicular wall or grow back to reenter the skin near the follicle, producing ingrowing hairs (23). Pseudofolliculitis may also occur if the hairs are plucked. This condition is extremely common in negroid men, and presents as an eruption of follicular papules or pustules on the sides of the neck and over the angles of the jaw (Fig. 41.1).

Men who cannot or will not stop shaving must, at least, avoid close shaving. A corticosteroid/antibiotic cream may be helpful in mild cases. A permanent treatment using retinoid acid and ammonium lactate is very useful. A twice-daily application of 8% glycolic acid lotion is an effective therapy, and allows the patient to resume a daily shaving regimen (24). The use of depilatory creams every other day or every three days may be advisable if a topical corticosteroid is used to counteract the irritation caused by the chemical depilatories. Barium sulfide depilatories act rapidly (within five minutes). They are the most convenient to use and give the smoothest shave, but they are characteristically malodorous. Calcium thioglycolate depilatories have a mercaptan or sulfide odor, which can be masked with fragrances. However, they do not leave the skin as smooth as do barium sulfide products (25).



**Figure 41.1 (A, B)** Pseudofolliculitis of the beard. *Source:* Courtesy of L. Dubertret (France).

## HAIR PRODUCTS

### Shampoos

The fundamental aim of shampoo is to clean hair and scalp. However, modern shampoos are also required to provide conditioning effects benefits. A variety of shampoos are marketed to meet the needs of each type of hair, habits, hairstyle and whims of the consumers.

### Conditioners

This category of products are designed to provide care and embellishment to hair. They include a vast range of products, most of them to be rinsed off (fluids, creams, mousses, gels, oils) or left on (lotions, gels, sprays, or glossing or hairstyling aids, etc.). Basic ingredients are cationic surfactants or polymers and silicones combined with vegetal oils, protein hydrolysates, fatty alcohols, sunscreens, and many others.

### Hair-Coloring Products

Two of the trends currently seen on the U.S. male market are the tinting of gray hair and staying trim. Despite the attraction of looking "distinguished," many men prefer the youthful look, and cover-up gray areas. As a result, the male hair-coloring market is growing.

### Metallic Gradual Hair Colors

"Gradual hair color," often referred to as "hair color restorers," are particularly popular among men with gray hair. These products generally consist of an aqueous solution of lead acetate containing suspended sulfur. They are applied daily, as a hair dressing. They are very handy and safe to use. Unfortunately, the final shade is difficult to control (26).

### Tone-on Tone Coloring

This product is based on the technology of tone-on tone coloring, which means oxidation coloring without lightening or bleaching. It is a foaming fluid gel, which colors gray hair within five minutes, giving a shade similar to the natural shade of hair.

It covers gray hair nicely when this averages up to 50% of the hair, always providing a very natural-looking result without any untoward highlights. It is a permanent coloring; that is, it resists shampoos until the next application, which is required only when gray hair has grown again.

Tone-on tone coloring involves the use of two components, which are mixed just prior to application on wet, but not shampooed hair. One of the components is the gel containing the oxidation dyestuffs (combination of primary intermediates, e.g., paradyes such as PPD) and derivatives and modifiers (27) with an alkali (ammonia or ethanolamine). The other component is hydrogen peroxide. Tone-on tone coloring requires only mild alkaline, in clear contrast with conventional oxidation coloring, which requires ammonia in a sufficient amount to generate enough active oxygen from hydrogen peroxide to lighten hair (to even the background shade of hair to which coloring is applied) or to bleach hair (when a lighter shade is desired). Tone-on tone coloring neither requires nor involves lightening or bleaching of hair.

### Hair Setting and Hairstyling Products

Give shape, build hairstyle and maintain it more or less strongly are the various goals assigned to such products which must continuously adapt to changing fashion and hairstyles. Gels, sprays, mousses are the main types. Their basic components are film-forming polymers which keep the shape and style over the time. Most products are designed to bring additional benefits such as better shine or conditioning and easier manageability depending on expectations.

### Repigmenting Gel "Progress Homme"

Progress Homme is a product whose coloring agent is a key intermediate in the natural biosynthesis of melanin namely 5,6-dihydroxyindole (DHI). This is a very sensitive colorless material that reacts easily with oxygen to produce a black pigment that has been shown by electronic paramagnetic resonance (EPR) and pyrochromatography to be similar to natural eumelanin of hair.

DHI is a very unstable material: it is very easily oxidized when exposed to air at ambient temperature. Any trace of metallic impurity leads to rapid oxidization. Therefore it has taken several years to find appropriate conditions for manufacturing DHI and formulating a stable, reliable, marketable product on an industrial scale.

Composition of Progress Homme gel is as follows:

- DHI
- Nonionic surfactant
- Gelifier
- Stabilizing system
- Alcohol, 12% volume

This product is designed for men with up to 50% gray hair. It gradually repigments gray hair by inducing the formation of natural-like pigment inside the hair. Gray hairs are progressively pigmented, restoring the natural shade of the hair.

Progress Homme is suitable for natural blond or brown hair. It is applied for 10 to 15 minutes (then rinsed) twice a week for approximately two weeks, and then every two or three weeks.

Despite this significant breakthrough and the opening of a new era in hair coloring, this progressive coloration of hair has not gained the popularity it deserves.

### Hair Thickeners

There has been a surge in the sale of "thickeners," although these provide only cosmetic benefit and do not help hair restoration (28).

### Minoxidil

Minoxidil is a piperidinopyrimidine derivative and a potent vasodilator, effective orally, for severe hypertension. When applied topically, minoxidil has shown to change conversion of vellus to terminal hair. No beneficial effect has been observed in the frontal area of the scalp.

2% topical minoxidil appears to be a safe therapy, with side-effects only of local irritation, which is increased with simultaneous use of topical 0.025% retinoic acid. Transitory hypertrichosis in unusual areas (forehead, temples, and cheeks) is rare. The explosive eruption of pyogenic granuloma on the scalp due to a topical combination therapy of minoxidil and retinoic acid is an exceptional event (29).

Patients should be informed that to maintain any beneficial effect, applications must continue twice daily for life even with the 5% minoxidil strength.

### Aminexil

Fibrosis of the connective sheath that surrounds the hair follicle has been identified as a factor associated with hair aging and loss in alopecic subjects. It may be responsible for shortening blood supply and hindering hair follicle anchoring in the deep dermis.

Perifollicular fibrosis is the result of abnormal changes in collagen production and maturation involving activation of an enzyme that generates collagen cross-linking.

A new active ingredient, 2,4-diaminopyrimidine oxide (2,4-DPO or Aminexil), that inhibits the expression of the enzyme implicated lysyl hydroxylase, has been shown to efficiently prevent seasonal hair loss and contribute to maintaining and improving hair density.

### Scalp Camouflage

#### *Tattooing-Dermopigmentation*

They may sometimes improve the aspect hair transplants.

#### *Hair Piece*

The traditional solution for the balding man has been the toupee. The main drawback of the wig has been its attachment. Partial baldness has often been camouflaged by the use of small hair pieces composed of synthetic or natural hair. These may be worn for as long as two months before being reset.

### WASHING PRODUCTS

The man of today feels the need to care for his appearance, to stay young and athletic, and to maintain a refined, yet virile, image. He wants products that are pleasant, efficient and simple to use every morning.

Body hygiene products includes soaps, soap bars, cleansing liquids, bubble baths (or foam baths), bath salts, body creams, and bath oils (or body milks) although bath oils and body milks are rarely used by men. Bath salts are soluble sodium salts in crystalline form which may be colored. They soften the water.

These products have a double role: to soften the skin and to make it supple. They are particularly recommended for athletes, whose skin suffers trauma from the sun, wind, seawater, snow, and sweat.

Soaps are composed of fatty acid salts obtained by saponification. In "soap cakes" (or soap bars) the soap has been replaced by nonionic synthetic tensioactive ingredients called "syndets."

Cleansing liquids are aqueous (or watery) solutions containing tensioactive agents, neutral or acid pH which can be added to various substances.

### ANTIPERSPIRANTS AND DEODORANTS

Sweating is a very masculine concern, especially when there are malodorous consequences to the feet. Odors are due to

the sweat constituents of apocrine glands in certain areas, principally the axillae, and, rarely, abnormal constituents in the sweat in metabolic diseases.

These odors result from the bacterial decomposition of the sweat produced by apocrine and eccrine glands. Eccrine bromhidrosis usually emanates from the feet. Excessive secretion produces softening of the stratum corneum, and bromhidrosis occurs as a result of bacterial action on the softened wet keratin. This explains its predilection for the soles of the feet and other intertriginous areas. Eccrine bromhidrosis tends to be maximal in young and middle-aged adults, and is increased by a raised ambient temperature, this contrasts with volar sweating, which is more responsive to emotional stimuli.

Athlete's foot results from the concomitant presence of bacteria, dermatophytes and hyperhidrosis. This latter should be treated along with the infection. Beside the use of fluffy tannic acid, antifungal powder may be very helpful in foot hygiene.

There are two main types of medical treatment: antiperspirants, which attempt to tackle the cause, and fragrances, which seek to mask the result. The distinction between antiperspirants and deodorants is usually confused by the consumer. This may explain some of his dissatisfaction with the results.

Antiperspirants, containing aluminum salts, tend to suppress the production of sweat. Deodorants, which may contain mild antibacterials such as benzethonium chloride or triclosan, are usually well perfumed. They work by masking the body odor (i.e., competing with it), destroying the smell (rare) or trapping the odor. For palmoplantar hyperhidrosis, tap water iontophoresis has been established as the most effective and inexpensive therapeutic modality (30).



## DEPILATORIES

At present, these are primarily used by athletes, and transvestites.

There are four main types of hair removal.

Mechanical depilation uses wax.

Chemical depilation is used especially as a treatment for pseudofolliculitis of the neck (see above).

Electrolysis is the only permanent method of hair removal, involving destruction of the hair root with an electric current. Today, a modified high-frequency electric current is used to destroy the hair by electrocoagulation. This has the advantage that it requires less time than true electrolysis. This technique is not recommended for large areas such as arms and legs.

Lasers are gaining popularity among the patients.

## PRODUCTS FOR THE SUN (SEE CHAPS. 23, 26, 27)

Sunscreens and self tanning.

## BEAUTY PRODUCTS

Apart from actors and transvestites using cosmetics designed for women, the market for makeup products is limited. It is restricted to bronzing gels, transparent facial powder and facial cover sticks designed to mask skin blemishes (10). Green facial cover sticks camouflage a reddish complexion by producing a brown tone.

Colorless nail polish dermatitis is of little significance. Only four cases have appeared in the literature between 1925 and 1993 (31).

We are far from the return to "Louis XV-type" pampering by males, but with increased education of men with regard to the need for skin care beyond daily basic grooming, the male skin care market will experience the growth expansion that many have been predicting for years.

## SOFT TISSUE FILLING IN MEN

For more than forty years—and especially since 1981 when the Zyderm<sup>®</sup> injectable bovine collagen received the FDA approval—the number of facial soft tissue filling techniques has increased and new molecules have been added, enabling numerous fillers to be developed. Until today, these treatments concerned mainly women. At present, they are increasingly proposed to men whose signs of aging are less discriminating, occur later but are however, less and less accepted.

Previously, the notion of aging was associated with skin changes only. Nowadays, the aging components—especially the facial ones—are identified as involving the skin, the musculoaponeurotic plane, the fat tissues and the bones. This recent knowledge has led to new approaches for the treatment of aging, including the filling of wrinkles and/or the restoration of volume, with products perfectly adapted to each type of demand (32).

Man's facial aging is specific. The physiological and functional characteristics of male skin are linked to the androgens, the secretion of which is much higher in men than in women (2). The free testosterone level is ten times higher and the 5 $\alpha$ -reductase is especially active in the skin. Skin thickness is globally more important in men (16% more than in women), which makes the skin more resistant. Moreover, men's skin has

a better hydration and is more elastic than women's (3,8). Thus, it is easier to understand the differences in intrinsic aging in men and women, which are further aggravated in men by a frequently deleterious environmental behavior: sun exposure, smoking, diet, shaving, alcohol, which all speed up this genetically determined natural process.

The observations of the physiological, functional and anatomical evolutions, completed by a clinical examination make it possible to explain the choice of a product, of a technique, of the doses to be injected; these choices are always different in men and in women.

## FILLING

The filling is a discreet, quick, safe and noninvasive treatment. It suits the active man, sometimes worried or even blocked by some preconceived ideas, yet increasingly looking toward progress and new "antiaging" techniques. Hence the increase in the number of procedures for men, which today represent 10% to 15% of the demands for fillers.

In most cases, he is an urban man, in his forties (the 36- to 45-year age bracket corresponds to 48% of the demands), who still feels young and does not like the face he sees in his mirror.

This man accepts his feminine part while claiming his virility, but with a natural and dynamic look. He pays attention to his appearance to assert or preserve his position in an increasingly demanding and critical society, where the judgement criteria are set by the media and the images they convey. A man wants a light treatment, with simple consequences, compatible with his social and professional activities, and his sentimental life.

Over the age of 50 (about 25% of the demands), the filling methods can become substitution therapeutics that compensate for the loss of volume, the displacement or loss of fat tissues. Moreover, demineralization at different levels increases the depth of wrinkles and folds (especially the marionette lines), and even promotes volume loss—hard to accept both physically and psychologically—and which may justify a demand for fillers.

Besides these antiaging filling and volume enhancing techniques, these procedures implemented with the same products, can be used to treat therapeutic sequelae (HIV) or congenital or posttraumatic morphological anomalies and to improve the scars of all etiologies.

## PATIENT SELECTION

Before any treatment the following process must be implemented whether the patient is a man or a woman.

An exhaustive medical interview should be carried out to identify autoimmune, allergic, granulomatous or viral pathologies, medication treatments (NSAI, immunosuppressors), herpes or major ENT history. All these factors may justify the systematic eviction of certain products or necessitate a double intradermal test prior to any treatment.

Possible aesthetic medical and surgical history and the follow-up of each procedure (keloid scars) should be identified.

The expectations—realistic or excessive—which can indicate in the patient a form of anxiety, fear, depression, or even dysmorphophobia—should be assessed.

The extent of the patient's hope, her/his needs for satisfaction, even sometimes the demands, as well as the fears should be ascertained.

A precise clinical examination should be carried out. Skin alterations, skin type, sun damages and/or skin laxity, possible anatomical, positional and dynamic asymmetries, should be recorded with photographs (face, profile, three quarters).

## PRODUCTS

Following the examination, the physician must choose the suitable product for both male and female patients on the basis of the individual characteristics of the patient: a degradable product, with skin resorption at varying rates (among which semipermanent products are included), or nondegradable products that remain in the skin for several years or even indefinitely.

### Degradable Products

#### *Collagens*

Currently less used. The Zyderm Zyplast<sup>®</sup> (Allergan), glutaraldehyde cross-linked with bovine collagen, necessitates a double test before treatment which limits its use (33). The Evolence<sup>®</sup> and Evolence Breeze (Johnson and Johnson), glycation-cross-linked porcine collagen, noticeably less immunogenic, are interesting especially for the treatment of the buccal region (34).

#### *Hyaluronic Acid*

Owing to its exceptional physicochemical qualities—hygroscopic, viscoelastic, antioxidant—this nonimmunogenic, non-species or tissue specific molecule has been developed for aesthetic surgery and medicine since 1995 (35). It is the most widely used molecule today (36,37). Depending on the different hyaluronic acid (HA) concentrations (18–26 mg/mL) and the different levels of molecule cross-linking, the HA-based products can meet demand for filling (wrinkles, folds, moderate cavities, minor morphological anomalies) or volumetric demands (fat loss, lack or ptoisis of cheekbones, blurry face contours, or major morphological modifications) (32,38).

Some of the products have been FDA approved: Restylane<sup>®</sup>, Restylane Perlane (Médicis) (39,40), Juvederm<sup>®</sup> Ultra, with lidocaine in Europe, without lidocaine in the United States (Allergan), Hydrelle<sup>®</sup>, first HA with lidocaine approved in the United States (Anika).

Other products already used are in the approval process, especially the volume enhancing products: Restylane Sub Q and Juvederm Voluma. The following products are also worth mentioning: Revanesse<sup>®</sup> and Revanesse Ultra (Prollenium Medical), Redexis<sup>®</sup>, Esthelis<sup>®</sup> (Anteis), Teosyal<sup>®</sup>, (Teoxane), Glytone (Pierre Fabre), Amalian<sup>®</sup> (Nordic Esthetics), commercialized in Europe, Puragen<sup>®</sup>, Puragen Plus, commercialized in Canada, etc.

Currently some work makes it possible to evoke HA as a fibroblastic stimulator (41).

#### *L-Polylactic Acid (Sculptra/Newfill: Sanofi Aventis)*

In 2004, Sculptra<sup>®</sup> achieved the FDA approval in the United States for the treatment of lipoatrophy in HIV patients (42,43). In 2003, Newfill<sup>®</sup> was approved in France for the therapeutical correction of jugal lipoatrophy. Other usages are, in fact,

“offlabel”: nasolabial folds, marionette lines, the chin and the oval of the face. This product must not be injected into the forehead, the lips, the neck, the décolleté and superficial small wrinkles. To minimize the possible side-effects, certain essential rules must be observed: no overcorrection, no deep injection and the intervals between the injections should be defined on the basis of the results (44,45).

Aliphatic polyester is a biocompatible, bioresorbable and immunologically inactive molecule that degrades at a slower rate than HA. It stimulates the collagen production of the fibroblasts. This is a progressive filling initiated by the induction of a new tissue. It is considered as a volume enhancer.

#### *Calcium Hydroxyapatite: Radiesse<sup>®</sup> (Bioform)*

This bioceramic is FDA approved for the jugal atrophies linked to HIV therapies, for the nasolabial folds and bone deformities. This product is injected deep into the dermis and subcutaneously as well as in the marionette folds and in the buccal folds. Its duration in situ (18 months) and the very few side-effects (minimal and reversible reactions to foreign bodies) make it an interesting product for volume augmentation. Its only contraindications is that it should not be injected in the fine or superficial wrinkle or in the periorbital or peribuccal regions (46–48).

#### *Nondegradable Products*

These products should be used for repair surgery or to fix deformities. Their permanent character is not really compatible with aesthetic indications which are evolutive per se.

Injections are always deep in the subcutaneous planes or can even be down to the bone.

*Polymethylmetacrylate: Artecoll<sup>®</sup> in Europe, Artefill<sup>®</sup> in the United States (Artes, Inc.).* Composed of PMMA microspheres in a bovine collagen solution at 3.5%, this product necessitates a double test before injection. It was FDA approved in 2006 for the nasolabial folds with a five-year moratorium. As for the previous products, a risk of late appearing granulomas exists (49,50).

*Polyacrylamide gels: Aquamid<sup>®</sup> (Contura International).* This product composed of 2% acrylic acrylamide polymer in water, was authorized in Europe in March 2001, as well as in Australia, South America and in the Middle East, but not in the United States. It gives good results in very deep nasolabial folds, for the correction of volume in the chin and the cheekbones, and for the filling of jugal lipoatrophy in HIV patients; infectious complications have been reported in France that led to drainage, excision and antibiotherapies, hence its use has been limited (51).

*Alkylimides: Bio-Alcamid<sup>®</sup> (Polymekon) 4% in water.* This product is EC approved, but not FDA approved. It is considered and injected as an extractable endoprosthesis. It may cause severe local infections that necessitate the removal of the product and even extensive repair of the infected tissues (52).

*Fluid silicon: Silikon 1000<sup>®</sup> (Alcon), Bioplastique<sup>®</sup> (Uroplasty).* In the United States and France this product has not been approved for injections to correct facial aging. In the United States, studies are in progress on HIV patients. This dimethylsiloxane is used “offlabel” in microdroplets and is used in deep intradermal injection; it gives excellent permanent correction at the level of the nasolabial folds and on scars. After a very long period of time (up to 20 years) it may however cause the formation of granulomas—sometimes very large—for which there is no satisfactory treatment (53–56).

Table 41.1 Fillers Proposal for Men According to Site

SITE	Collagen	Hyaluronic Acids			Volume Enhancers	
	X-linked	Moderately X linked	Highly X linked	Volume Enhancer	HAP	APL
Horizontal forehead						
Interbrow						
Nose transverse wrinkles						
Cheekbones						
Peri-orbital						
Bags						
Nasolabial folds						
Jugal wrinkles (long)						
Jugal atrophy						
Lip contour						
Lip volume						
Labial commissures						
Labio-chin depressions						
Chin						
Maxillary contours						
Acne scars						
Nasal hump						
Projecting chin						
Fronto-nasal angle						

*Acrylic hydrogels: Dermalive<sup>®</sup>, Dermadeep<sup>®</sup> (Dermatech).*

These products—EC labeled in 1999—are no longer on the European market and were never approved in the United States. Three to 10 years after the injections, it is still possible to see new cases of inflammatory, chronic, purple, inesthetic, and invalidating granulomas which have led to the prohibition of the product.

#### CHOICE OF THE PRODUCTS DEPENDING ON THE SITE

Male patients often want a specific site to be treated rapidly with good results and with only one or two treatments. Generally, considering the type of skin and the depth of the wrinkles, the products selected are denser than those used for female patients to treat the same sites (Table 41.1). It is nevertheless advisable to consider the anatomical zone as a whole and to treat it entirely, which may lead to the utilization of several products and therefore imply several sessions.

#### Nasolabial Folds

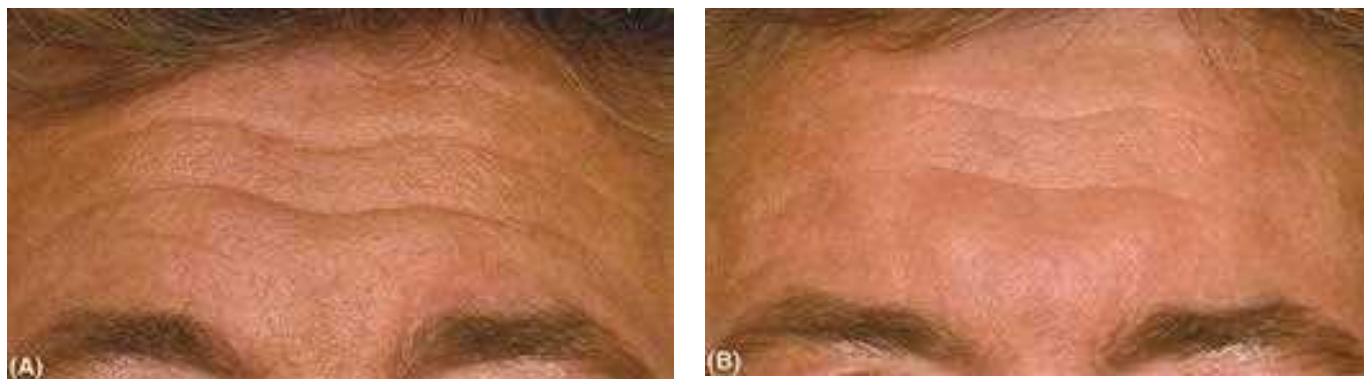
This is the most frequent demand for correction. In male patients these folds are often deep and sometimes aggravated by the projection of a ptotic cheek. The injection should be carried out in the medium or deep dermis using a highly cross-linked product (HA), or in the deep dermis or in the supra-periosteal zone using a slow degradable product (calcium hydroxyapatite or polylactic acid) (Fig. 41.2A, B).

If the fold is very deep and the loss of volume significant, a volume enhancing product should be considered or even autologous fat (point not discussed in the present article).

A ptotic cheek always increases the depth of the nasolabial fold and often leads to injecting a jugal volume enhancing product to compensate for the loss of volume and rebalance the medial part of the face. It is also possible to inject a volume enhancing product in the cheekbone and through cutaneous extension, obtain an artificial reduction of the depth of the nasolabial fold.



Figure 41.2 (A) Deep nasolabial folds before injection. (B) After injection of calcium hydroxyapatite (Radiesse<sup>®</sup>).



**Figure 41.3** (A) Forward lines before injection. (B) After Restylane<sup>®</sup> injection.

### Jugal Wrinkles

In men, these wrinkles are often real gashes. Often unique, long and deep, this so-called “pillow” wrinkle which corresponds to a nocturnal unilateral bearing position, can be injected with a product that is moderately or highly cross-linked.

The superficial multiple wrinkles (jugal splitting in women) are almost nonexistent in men.

### The Glabella or the Interbrow Wrinkles

There is a frequent demand for correction in this zone. It concerns deep wrinkles which are genetic, static and dynamic, hence difficult to inject and even more so since the skin is thick, oily and the pores are open. As in women, this zone is very sensitive; there have been severe necroses or hematomas following the injection of excessively cross-linked or volume enhancing products.

In fact, to achieve any major improvement at this level, there is a need for the combination of a treatment that associates botulinum toxin and a filler.

### Forehead Wrinkles

#### *Horizontal Wrinkles*

In male patients, the cutaneous tissue is very thick and there are few wrinkles, but they are very deep even at rest. In this case, a moderately cross-linked HA should be injected along the whole wrinkle, without overcorrection, to achieve good results where the Botulinum toxin has little efficacy (Fig. 41.3A, B). In the case of atrophic foreheads, fine expression wrinkles are more obvious. Botulinum toxin clearly improves wrinkles, and can be completed with a moderately cross-linked filler injected in a multipoint procedure.

#### *Vertical Wrinkles*

Men often exhibit static wrinkles linked to a nocturnal position defect. In this case, filler injections using a moderately reticulated product give excellent results.

### Buccal Region

In male patients, the demand concerns mainly the augmentation of lip volume since peribuccal wrinkles are very rare in men except in heavy smokers. As a general rule, it is preferable

to inject only in the labial curl not to feminize the mouth. To improve lip volume, a few injections can be made in the dry mucosa. Moderately or highly cross-linked HA should be used; volume enhancing products should be avoided since their resorption can be difficult at this level and cause the development of nodules.

### The Periorbital Region

#### *Crow's Feet Wrinkles*

Usually, Botulinum toxin provides a dramatic improvement of these aging signs and patients are satisfied.

#### *Eye Bags*

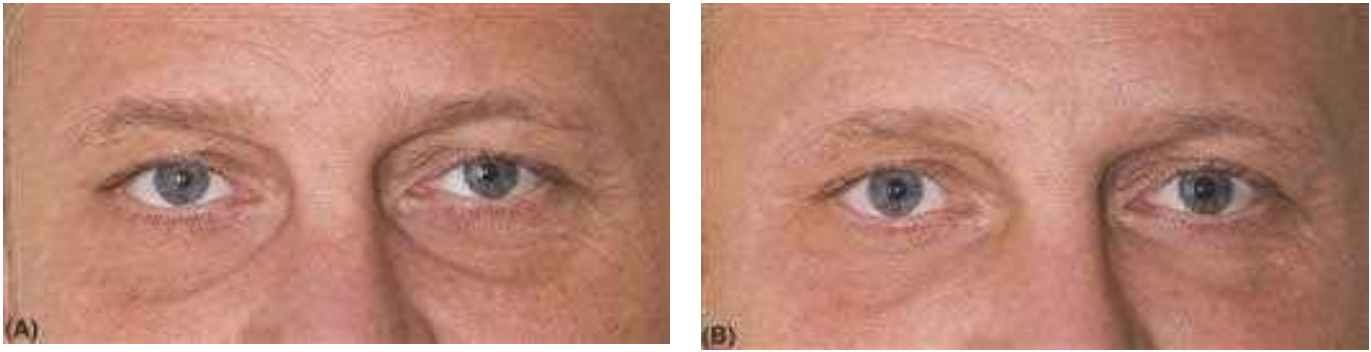
This is an increasingly frequent demand since eye bags are felt as signs of permanent tiredness and hence of aging. Prior to selecting a treatment, the whole orbital region must be studied and the type and origin of the eye bags must be identified. If the injection is justified, at this level and the level of the tear trough (jugo palpebral trough), moderately or highly cross-linked HA should be injected with priority given to the least hydrophilic acids that enable volume wise corrections to be achieved without any overcorrection (Fig. 41.4A, B).

### Cheekbones

The request—relatively frequent—for cheekbone reconstruction, should be answered with the injection of moderately or highly cross-linked HA without overcorrection. Attention should be paid to the possible occurrence of major edema caused by the hydrophilic nature of the HA.

### Marionette Lines (Labiochin Folds)

These so-called “marionette” lines correspond to the wrinkles and depressions that run from the lip commissure to the angulamaxillary region. Their width and depth depend on the morphology and mobility of the face; they are aggravated by ptosis and the displacement of the jugal fat linked to aging. In fact the objective is to replace the lost volume and not to reduce the wrinkles. Therefore, if the depressions are important, the injection can be carried out on two superimposed planes, with two different products: highly cross-linked in the deep plane and moderately cross-linked in the medium plane (Fig 41.5A, B).



**Figure 41.4** (A) Tear trough before injection. (B) After Restylane® injection.



**Figure 41.5** (A, B) Incomplete filling of nasolabial folds and marionette lines after injection of Perlane®.



**Figure 41.6** (A) Very deep nasolabial folds before injection. (B) After treatment with both medium and deep fillers (hyaluronic acid).

The modifications of the subjacent bone mass as well as that of the peribuccal muscles increase the depth of these folds in men. They may cause saliva, food and irritant agents to stagnate at the bottom of the folds, thus causing bacterial or candidosic proliferation. In such a case the region must be

“unsplitted,” not for aesthetic reasons but for the comfort and the hygiene of the patient. This filling could be completed by the injection of a highly cross-linked product or even a volume enhancing product at the level of the contour of the face (Fig. 41.6A, B).

**A Few Specific Indications and Sites Concerning Men**

*The Dorsum and the “Saddling” (Flattening) of the Nose*  
 These morphological, posttraumatic, or postsurgical damages can be treated often with spectacular results, by filling using a highly cross-linked HA or even calcium hydroxyapatite.

**Raising the Tip of the Nose**

In elderly men, injecting a moderately cross-linked product at the base of the internostril wall may suffice.

**The Chin**

In a man’s face, a receding chin, insufficiently broad or poorly contoured may cause a form of “unenergetic” complex. It can be modified to achieve a more virile aspect of the face by carrying out deep vertical injections of highly cross-linked HA.

**SIDE-EFFECTS**

The sides effects have already been mentioned, and they are listed in Tables 41.2 (degradable products) and 41.3

(nondegradable products) (Fig. 41.7A, B). A treatment is mentioned for each side-effect (57–59).

*A few recommendations to minimize complications are as follows:*

- Do not overcorrect.
- Do not inject excessive doses during the first session.
- Do not mix different products in a single site in one session.
- Avoid injecting degradable products on sites which have already been injected even several years before (unquestionable clinical observations without scientific evidences).
- Do not inject highly cross-linked or volume enhancing products in the semimucosa or in the sites with a very thin skin to avoid residual nodules.
- Limit the injections of nondegradable products as much as possible.
- Be cautious with hepatitis C patients. Recently, cases of severe granulomas have been reported in hepatitis C patients treated with Interferon, and injected several years before with nondegradable filler products, and this on all the injected sites. Patients should be informed about this possible risk.

**Table 41.2** Possible Complications of Degradable Fillers and Treatment

Time to occurrence of the side-effects	Side-effects	Duration	Treatment	Evolution	
<i>Immediate</i> 1 day to 1 wk	Overcorrection	x weeks	None	Spontaneous clearance ± slow	
	papulas, asymmetry	±8 days	Ice: arnica	Spontaneous clearance ± slow	
	Hematomas	±8 days	Possible local corticosteroids	Spontaneous clearance without sequela	
	Erythema, edema	±8 days	Possible local corticosteroids	Spontaneous clearance without sequela	
	Hypersensitivity	±8 days	Possible local corticosteroids	Spontaneous clearance without sequela	
	Prurit (rare)	±8 days	Possible local corticosteroids	Spontaneous clearance without sequela	
	Acneiform folliculites	5–7 days	Local antiseptic	Spontaneous clearance without sequela	
	Herpes crisis	8 days	Local and per os aciclovir	Spontaneous clearance without sequela	
<i>Semidelayed</i> 1–3 wk	Necrosis (technical error)	Variable	Spontaneous or controlled scarring	Spontaneous clearance without sequela Disappearance Healing Scar ± obvious	
	Pigmentation (HA)	1–6 mo	None	Progressive clearance	
<i>Delayed</i> 3–24 mo	Overcorrection, asymmetry	3 mo	Possibly cortisoned topic agent	Clearance	
	<i>Collagens and HA:</i> Collagen allergy Erythema Granuloma (exceptional) Abscess	Variable	Local and general with corticosteroids	Restitution <i>ad integrum</i>	
		1 to several months	(1–3 wk)		
		<i>Polylactic acid:</i> Mininodules palpable but invisible Larger but rare granulomas (technical error)	x wk	Intralesional corticosteroids ±5	Usually spontaneous clearance
			x mo (<2 yr)	FU or 5 FU alone. Surgery? Laser?	Diminution or persistence
	<i>Calcium hydroxyapatite:</i> Small nodules possible	A few weeks	No treatment	Slow disappearance	

*Abbreviation:* HA, hyaluronic acid.

**Table 41.3** Possible Complications of Nondegradable Fillers and Treatments

Time to occurrence of the side-effects	Side-effects	Duration	Treatment	Evolution
<i>Immediate</i> 1 day to 1 wk	<i>Hematomas</i> <i>Erythemas</i> <i>Pain</i> <i>Edemas</i> <i>Prurit</i>	1 wk to 1 mo	Local and general corticosteroids	Spontaneous clearance without sequela
<i>Delayed</i>	<i>Telangiectasias</i> <i>Asymmetry</i> <i>Overcorrection</i>	Variable	Laser Correction Hyaluronidase?	Slow improvement
<i>Polymethylmetacrylate</i> (6–12 mo) Artefill <sup>®</sup> <i>Acrylic hydrogels</i> (1–7 yr) Dermalive <sup>®</sup> Dermadeep <sup>®</sup>	<i>Granulomas</i> Invalidating and durable	Variable: Several months Several years Definitive (acrylic hydrogels)	Antibiotherapy (cyclines) Synthetic antimalarial Oral and intralesional corticotherapy ±5 FU Surgery Laser Topic and oral immunomodulators?	Variable: Diminution of Granulomas Evolution through bouts Diminution of lesions through spontaneous Extrusion Persistence of Granulomas Disappearance after surgery Reappearance after surgery
<i>Polyacrylamides</i> (A few weeks) Aquamid <sup>®</sup>	<i>Indurations</i> <i>Granulomas</i> <i>Abscess</i>	Variable: 1 mo or longer	Antibiotics: Corticoids Excision Drainage	Variable Variable: 1–3 mo Variable
<i>Alkylimides</i> (A few days or weeks) Bio-Alcamid <sup>®</sup>	<i>Abscess</i> <i>Suppuration</i> <i>Indurated plaques</i>	A few weeks	Excision Antibiotics and surgery Antibiotics and surgery	Sometimes chronic suppuration
<i>Silicone fluid</i> (1–20 yr)	<i>Granulomas</i>	Definitive	Surgery owing to the total lack of efficacy of the intralesional corticoids and of all the oral or local therapeutics Laser CO <sub>2</sub> Erbium LP	Generally persistence

**Figure 41.7** (A, B) Indurated cheek and perioral area appeared three years after injection of alkylimid (Bio-Alcamid<sup>®</sup>).

## CONCLUSION

The effectiveness of the fillers available today allow us to satisfy the increasing aesthetic demands of male patients, which concerns all ages. The goal of these men is to recover a dynamic and younger appearance without having to undergo visible facial surgery. Filling and volume enhancing products, handled by well trained physicians, provide noninvasive, discreet and usually very efficient solutions.

## REFERENCES

1. Frost & Sullivan. The US male. SPC 1990; 63:29–31.
2. Tur E. Physiology of the skin. Differences between women and men. *Clin Dermatol* 1997; 15:5–16.
3. Shuster S, Black MM, Mc Vitie E. Influence of age and sex on skin thickness, skin collagen and density. *Br J Dermatol* 1975; 93:639–643.
4. Shuster S, Black MM, Bottoms E. Skin collagen and thickness in women with hirsuties. *Br Med J* 1970; 4:772.
5. Black MM, Shuster S, Bottoms E. Osteoporosis, skin collagen and androgen. *Br Med J* 1970; 4:773–774.
6. Burton JL, Johnson C, Libman L, et al. Skin virilism in women with hirsutism. *J Endocrinol* 1972; 53:349.
7. Tidman MJ, Eady RA. Ultrastructural morphometry of normal human dermal-epidermal junction. The influence of age, sex, and body region on lamellar and nonlamellar components. *Invest Dermatol* 1984; 83:448–453.
8. Humbert PH, Bombal C, Mac Mary S. Differences in biophysical properties of the skin between men and women. Congress of skin in health and disease the non invasive approach. Paris, June 2002.
9. Helmdach M, Thielitz A, Ropke EM, et al. Age and sex variation in lipid composition of human fingernail plates. *Skin pharmacol Appl Skin Physiol* 2000; 13:111–119.
10. Brosche T, Dressler S, Platt D. Age-associated changes in integral cholesterol and cholesterol sulfate concentrations in human scalp hair and finger nail clippings. *Aging Clin Exp Res* 2001; 13:131–138.
11. Orentreich N, Markofsky J, Vogelmann JH. The effect of aging on the rate of linear nail growth. *Invest Dermatol* 1979; 73:126–130.
12. Cunliffe WJ, Shuster S. Pathogenesis of acne. *Lancet* 1969; 1:685–687.
13. Rees J, Shuster S. Pubertal induction of sweat gland activity. *Clin Sci* 1981; 60:689–692.
14. Cua AB, Wilhelm KP, Maibach HI. Elastic properties of human skin: relation to age, sex, and anatomical region. *Arch Dermatol Res* 1990; 282:283–288.
15. Cooke JP, Creager MA, Osmundson PJ, et al. Sex differences in control of cutaneous blood flow. *Circulation* 1990; 82:1607–1615.
16. Mc Ternan PG, Anwar A, Eggo MC, et al. Gender differences in the regulation of P450 aromatase expression and activity in human adipose tissue. *Int J Obesity* 2000; 24:875–881.
17. Querleux B, Cornillon C, Jolivet O, et al. Anatomy and physiology of subcutaneous adipose tissue by in vivo magnetic resonance imaging and spectroscopy: relationships with sex and presence of cellulite. *Skin Res Technol* 2002; 8:118–124.
18. Nürnberger F, Muller G. So-called cellulite: an invented disease. *J Dermatol Surg Oncol* 1978; 4:221–229.
19. Forster J. Men make their mark. *Eur Cosmet Markets* 1999; March:50–51.
20. Edman B. The influence of shaving method on perfume allergy. *Contact Dermatitis* 1994; 31:291–292.
21. Draeos ZK. *Cosmetics in Dermatology*. 2nd ed. New York, Edinburgh: Churchill Livingstone, 1995.
22. Schoen LA, Lazar P. *The Look You Like*. New York: Marcel Dekker, 1990.
23. Dawber RPR. *Diseases of the Hair and Scalp*. 3rd ed. Oxford: Blackwell, 1997.
24. Pericone NV. Treatment of pseudofolliculitis barbae with topical glycolic acid. *Cutis* 1993; 52:232–235.
25. Halder RH. Pseudofolliculitis barbae and related disorders. *Dermatol Clin* 1988; 6:407–412.
26. Corbett JF. Hair care products. In: Demis J, ed. *Clinical Dermatology*. Philadelphia: Lippincot-Raven, 1996:2–44.
27. Zviak C. *Science Des Traitements Capillaires*. Paris: Masson, 1988:235–286.
28. Simpson NB, Barth JH. Hair patterns: hirsuties and baldness. In: Dawber RPR, ed. *Diseases of the Hair and Scalp*. 3rd ed. Blackwell Scientific Publications: Oxford, 1997:67–122.
29. Baran R. Explosive eruption of pyogenic granuloma on the scalp due to a topical combination therapy of minoxidil and retinoic acid. *Dermatologica* 1989; 179:76–78.
30. Sloan JB, Soltani K. Iontophoresis in dermatology. *J Am Acad Dermatol* 1986; 15:671.
31. Hausen BM. Nagellack-allergie. *Z Hautkr* 1994; 69:252–262.
32. Pons-Guiraud A, Bui P. *L'art du Comblement et de la Volumétrie en Esthétique*. Arnette Ed. Paris, 2009; 289.
33. Klein AW. Tissue augmentation in clinical practice. In: Klein AW, ed. *Procedures and Techniques*. 2nd ed. New York, 1998.
34. Pons-Guiraud A, Rossi AB, Pomarède N. Evolence: le nouveau collagène bio compatible de longue durée. *Nouv Dermatol* 2007; 26:3–7.
35. Inoue S. Skin hyaluronan: its metabolism and role in skin physiology. *Connect Tissue* 33:235–243.
36. Monheit GD, Coleman KM. Hyaluronic acid fillers. *Dermatol Ther* 2006; 19:141–150.
37. Matarasso SL, Carruthers JD, Jewell ML. Restylane consensus group. Consensus recommendations for soft tissue augmentation with non animal stabilized hyaluronic acid. *Plast Reconstr Surg* 2006; 117:3S–4S.
38. De Lorenzi C, Weinbret M, Solish N, et al. Multicenter study of efficacy and safety of subcutaneous non-animal-stabilized hyaluronic acid in esthetic facial contouring: interim report. *Dermatol Surg* 2000; 32(1):208–221.
39. Rhoda S, Narins PC, Frederic S, et al. A randomized, multicenter study of the safety and efficacy of dermicol-P35 and non-animal-stabilized hyaluronic acid gel for the correction of nasolabial folds. *Dermatol Surg* 2007; 33:S213–S221.
40. Matarasso SL, Carruthers JD, Jewell ML. Consensus recommendations for soft tissue augmentation. *Reconstr Surg* 2006; 117(3 suppl):30S–34S.
41. Wang F, Garza LA, Kang S, et al. In vivo stimulation of de novo collagen production caused by cross-linked hyaluronic acid dermal filler injections in photodamaged human skin. *Arch Dermatol* 2007; 143:155–163.
42. Valentin MA, Aubron-Olivier C, Ghosn J, et al. Poly lactic acid implants New-Fill to correct facial lipatrophy in HIV-infected patients: results of the open-label study VEGA. *AIDS* 2003; 17:2471–2477.
43. Burgess CM, Quiroga RM. Assessment of the safety and efficacy of poly-L-lactic acid for the treatment of HIV-associated facial lipatrophy. *J Am Acad Dermatol* 2005; 52(2):233–239.
44. Lowe NJ. Dispelling the myth: appropriate use of poly-L-lactic acid and clinical considerations. *J Eur Acad Dermatol Venereol* 2006; 20(suppl 1):2–6.
45. Vleggar D. Soft tissue augmentation and the role of poly-L-Poly lactic acid. *Plast Reconstr Surg* 2006; 118(suppl):46S–55S.
46. Tzikas TL. Evaluation of the Radiance FN soft tissue filler for facial soft tissue augmentation. *Arch Surg Plast facial* 2004; 6:234–239.
47. Moers-Carpi M, Vogt S, Santos BM, et al. A multicenter randomized trial comparing calcium hydroxyapatite to two hyaluronic acids for treatment of nasolabial folds. *Dermatol Surg* 2007; 33:S144–S151.
48. Alam M, Yoo SS. Technique for calcium hydroxylapatite injection for correction of nasolabial folds depression. *J Am Acad Dermatol* 2007; 56:285–289.
49. Carruthers A, Carruthers J. Polymethylmetacrylate microspheres/collagen as a tissue augmenting agent. *Dermatol Surg* 2005; 31:1561–1572.
50. Cohen SR, Berner CF, Busso M, et al. Artefill: a long lasting injectable wrinkle filler material. *Plast Reconstr Surg* 2006; 118(suppl): 64S–76S.



51. Von Buelow S, Von Heimburg D, Pallua N. Efficacy and safety of Polyacrylamide Hydrogel for facial soft-tissue augmentation in a 2 year follow-up. *Plast Reconstr Surg* 2006; 118:85S–91S.
52. Fontdevilla J, Martinez E, Guisantes E, et al. Complications with BioAlcamid® in the Esthetic treatment of Lipoatrophy. 8th International Workshop on Adverse Drug Reactions and Lipodystrophy in HIV, September 2006. Abstract number 100.
53. Duffy DM. Liquid silicone for soft tissue augmentation. Histological, clinical, and molecular perspectives. In: Klein AW, ed. *Tissue Augmentation in Clinical Practice*. 2nd ed. New York: Taylor & Francis Group, 2006:141–238.
54. Orentreich D. Liquid injectable silicone: techniques for soft tissue augmentation. *Clin Plast Surg* 2000; 27:595–612.
55. Chui E, Sheel Sharl SH, Siebert J. Salvage of silicone-treated Facial deformities using autogenous free tissue transfer. *Plast Reconstr Surg* 2005; 116:1195–2005.
56. Narins RS, Bowman PH. Injectable skin fillers. *Clin Plast Surg* 2005; 32:151.
57. Murray CA, Zloty D, Warshawski L. The evolution of soft-tissue fillers in clinical practice. *Dermatol Clin* 2005; 23:343.
58. Lemperlé G, Morhenn VB, Charrier U. Human histology and persistence of various injectable fillers substances for soft tissue augmentation. *Esthetic Plast Surg* 2003; 27:354–360.
59. Lemperlé G, Rullan P, Gauthier-Hazan N. Avoiding and treating dermal complications. *Plast Reconstr Surg* 2006; 118:925–1075.

## Ethnic cosmetics

Enzo Berardesca, Grazia Primavera, Manuela Carrera, and Howard I. Maibach

### INTRODUCTION

Nowadays, the vast majority of the world's population is constituted by persons with skin of color, including a heterogeneous group of people with skin phototypes that fall within III to VI.

Racial differences in skin physiology and reaction to environmental stimuli are more and more described (1), but notwithstanding the increasing number of studies, data are often conflicting. In fact, it is difficult to define and interpret the cutaneous pathophysiologic phenomena that are not only anatomical and functional characteristics of ethnic groups but also the result of socioeconomic, hygienic, and nutritional factors. Furthermore, skin status may be influenced by climate, circadian rhythms, and changes in circulating sex hormones or stress hormones. Indeed, even though it is well established that all humans belong to the same species, many physical differences exist among human population. This chapter reviews the more consistent differences reported between racial groups and their implications in determining different responses after use of topical products and in treating skin aging.

### SKIN COLOR

According to the classification of Fitzpatrick, Caucasians are generally included in phototypes I to III, having fair complexion, red to light brown hair, tendency to sunburn, and tanning difficultly whereas colored skin belongs to skin type IV, V, or VI, rarely burning, tanning easily. Phenotypically ethnic skin ranges from brown to black-brown.

Clearly, differences in skin color are the most striking characteristic in ethnic skin. The color of the skin is due to the combination of four chromophores such as hemoglobin, oxygenated hemoglobin, exogenously produced carotenoids, and melanin. Melanin is the most important pigment for the determination of skin color. It is synthesized by melanocytes, stored into specialized organelles called melanosomes that are then transferred to the neighboring keratinocytes of the malpighian layer through dendrites.

Melanin represents an innate sun protection due to its ability to absorb UV light as well as light from the visible and near-infrared spectrum. During evolution, the development of adaptive mechanisms has led to differences in the size, number, and distribution of melanosomes between races and therefore differences in skin pigmentation (2).

Compared to other ethnic groups, the number and the size of melanosomes are higher in blacks and Australian aborigines; furthermore melanosomes are singly scattered and not distributed in clusters as highlighted in Caucasians and in orientals such as Japanese, Chinese, and Mongoloids. In all races, melanin is distributed along the basal layer of the dermoepidermal junction (DEJ) but in dark skin types the

number of pigmented cell layers is higher than in white skin as well as melanin concentration as confirmed by *in vivo* laser scanning confocal microscopy (3). The increased quantity of melanin correlates with the activity of tyrosinase and probably with the level of protease-activated receptor-2 (PAR-2) that is involved in melanosome transfer from melanocyte to keratinocyte (4). No interracial variation concerning the number of melanocytes has been reported.

### STRATUM CORNEUM STRUCTURE

Stratum corneum is equally thick in black and white skin (5,6). However, Weigand et al. demonstrated that the stratum corneum in blacks contains more cell layers and requires more cellophane tape strips to remove than the stratum corneum of Caucasians (7). They found great variance in values obtained from black subjects, whereas data from white subjects were more homogeneous. No correlation existed between the degree of pigmentation and the number of cell layers. These data could be explained by greater intercellular cohesion in blacks resulting in an increased number of cell layers and an increased resistance to stripping. This mechanism may involve lipids, because the lipid content of the stratum corneum ranges from 8.5% to 14%, with higher values in blacks (8). This result was confirmed by Weigand et al. who showed that delipidized specimens of stratum corneum were equal in weight in the two races (7). Johnson and Corah found the mean electrical resistance of adult black skin to be twice that of adult white skin, suggesting an increased cohesion or thickness of the stratum corneum (9).

Corcuff et al. (10) investigated the corneocyte surface area and spontaneous desquamation and found no evidence of differences concerning corneocyte size between black, white, and oriental skin. However, an increased desquamation (up to 2.5 times) was found ( $p < 0.01$ ) in blacks. They concluded that the differences may be related to a different composition of the intercellular cement of the stratum corneum. These data are contradicted by Warrier et al. (11) who reported higher desquamation index in whites compared with blacks. The recent investigations of Fotoh et al. (12) did not report any difference in the desquamation index between blacks and Caucasians.

Sugino et al. (13) found significant differences in the amount of ceramides in the stratum corneum, with the lowest levels in blacks (50% lower) followed by Caucasian and Hispanics (total ceramides:  $10.7 \pm 4.7$   $\mu\text{g}/\text{mg}$ ,  $20.4 \pm 8.1$   $\mu\text{g}/\text{mg}$ ,  $20.0 \pm 4.3$   $\mu\text{g}/\text{mg}$ , respectively;  $p < 0.05$ ). Though they note that water content levels were highest in Asians, they do not document the ceramide levels of Asians. In this experiment, ceramide levels were inversely correlated with transepidermal water loss (TEWL) and directly correlated with water content. These data may partially explain the controversial findings in the literature on the mechanisms of skin sensitivity.

Kompaore et al. (14) evaluated TEWL and lag time after application of a vasoactive compound (methyl nicotinate) before and after removal of the stratum corneum by tape stripping. Before tape stripping, TEWL was 1.3 times greater in blacks and Asians compared to Caucasians ( $p < 0.01$ ); no difference was found between blacks and Asians, whereas after stripping they found a significantly higher TEWL in blacks and Asians than in Whites. In particular, after stripping Asians showed the highest TEWL (Asians 1.7 times greater than Caucasians). They conclude that, similar to previous studies (15,16), skin permeability measured by TEWL is higher in blacks than in Caucasians. They also conclude that Asian skin has the highest permeability among the groups studied. However, these findings have not yet been duplicated. In fact, Sugino et al. (13) also included Asians in their study but found that baseline TEWL was, in decreasing order, blacks  $>$  Caucasians  $\geq$  Hispanics  $\geq$  Asians. Another study referenced in a review article (17) about Asian skin has compared TEWL in Asians and Caucasians and found no statistically significant differences at baseline or after stripping; however, no vasoactive substance was applied.

Reed et al. (18) found differences in the recovery of the barrier between subjects with skin type II/III compared to skin type IV, but no differences between Caucasians in general and Asians. Darker skin recovered faster after barrier damage induced by tape stripping.

### STRATUM CORNEUM WATER CONTENT

TEWL, skin conductance, and skin mechanical properties have been measured under basal conditions in whites, Hispanics, and blacks to assess whether skin color (melanin content) could induce changes in skin biophysical properties (19). Differences appear in skin conductance are more marked in biomechanical features such as skin extensibility, skin elastic modulus, and skin recovery.

They differ in dorsal and ventral sites according to races and highlight the influence of solar irradiation on skin and the role of melanin in maintaining it unaltered.

Wilson et al. (15) demonstrated higher in vitro TEWL values in black compared to white skin taken from cadavers. They also found differences in black and white skin physiology; in fact, the TEWL of both races increased with skin temperature. In their own study, they concluded that black skin would have a greater rise to achieve the same temperature and therefore a higher TEWL.

Since TEWL depends on passive water loss that is theoretically directly related to the ambient relative humidity and temperature (20), then, the increased TEWL in black skin could be associated with an increase in temperature because it is well established that a difference in black and Caucasian temperature exists.

Most studies using the forearm, back, and inner thigh (13,16,21,22) show a greater TEWL in blacks compared to whites; however, Warriar et al. (11) have demonstrated, studying a larger sample size, that TEWL is less in blacks than whites when measuring on the cheeks and legs. On the other side, in a recent study Fotoh et al. (12) did not find any difference between black and Caucasian women in TEWL evaluation, neither on the forehead nor on the volar forearm. As well, they reported that the mean hydration index, determined by the measurement of the electric capacitance using a corneometer, was similar in all groups.

Racial differences in TEWL exist neither on the volar nor on the dorsal forearms. However, water content is increased in

Hispanics on the volar forearm and decreased in whites (compared only to blacks) on the dorsal forearm. These findings partially confirm previous observations (16,23). Skin lipids may play a role in modulating the relation between stratum corneum water content and TEWL resulting in higher conductance values in blacks and Hispanics.

Racial differences in skin conductance are difficult to interpret in terms of stratum corneum water content, because other physical factors, such as the skin surface or the presence of hair, can modify the quality of the skin-electrode contact. In all races, significant differences exist between the volar and dorsal forearms (19). These results are in apparent contrast with TEWL recordings. Indeed, increased stratum corneum water content correlates with a higher TEWL (24). The data may be explained on the basis of the different intercellular cohesion or lipid composition. A greater cell cohesion with a normal TEWL could result in increased skin water content.

However, TEWL studies are characterized by a large interindividual variability and biased by environmental effects and eccrine sweating. To bypass these influences, an in vitro technique for measuring TEWL was used to compare TEWL in two racial groups (blacks and whites) (15). Black skin had a significantly higher mean TEWL than white skin. In both groups, a significant correlation between skin temperature and increased TEWL was found ( $p < 0.01$ ). The data confirm differences between races found in in vivo studies (16,23).

### STRATUM CORNEUM pH

The acidity of the skin mostly derives from the fatty free acid content of the skin surface and the buffer capacity of the skin is due to several mechanisms, one of the most important is the lactic-acid-lactate system.

According to Berardesca et al. (22), pH values in skin surface, measured on the volar forearm, are similar in black and in Caucasian women, but it decreases after tape stripping only in black subjects. Whereas Warriar et al. (11) who measured the pH on the cheek reported a significantly lower pH in black women than in the Caucasian ones. The results of Fotoh et al. (12) are quite the reverse: a significantly higher cutaneous pH in black women compared to the other groups.

### CUTANEOUS APPENDAGES

Although the amount of sweat is variable between racial groups, with more sweat secretion found in black subjects, the phenomenon does not derive from differences in gland number but more likely from differences in density of actively sweating glands (25).

Concerning apocrine glands, studies highlight that, compared to Caucasians and Chinese, blacks present apocrine glands greater in number and size (25).

Evaluating the sebum quantity present on skin surface, measured on the forehead using Sebumeter<sup>®</sup>, Fotoh et al. (12) showed similar results in all groups. In contrast with previous studies that reported significantly higher level of sebum secretion in black people in comparison with white subjects.

### SKIN DISEASE AND COSMETIC PROBLEMS Irritant and Allergic Contact Dermatitis

In 1919, Marshall et al. investigated cutaneous reactions to 1% dichloroethyl sulfide in whites and blacks (26). A drop on the forearm elicited erythema in 58% of white but only 15% of black

subjects, suggesting a decreased susceptibility to cutaneous irritants in blacks. Weigand and Mershon studied patch test reactions to *ortho*-chlorobenzylidene malononitrile (27). The results indicated that blacks were more resistant and required a significantly longer exposure to develop an irritant reaction. Subsequently, Weigand and Gaylor measured minimal perceptible erythema in blacks and whites after applying dinitrochlorobenzene to intact skin and to skin after the stratum corneum was largely removed by tape stripping (28). The results confirmed that blacks were generally less susceptible to cutaneous irritants. However, this difference was not detectable when the stratum corneum was removed. They also observed that the range of reactions in normal skin in both races was wider than in stripped skin, suggesting that the stratum corneum may modulate the different racial responses to skin irritants.

Irritation, as measured by TEWL (16,23), revealed a different pattern of reaction in whites after chemical exposure to sodium lauryl sulfate. Blacks and Hispanics developed stronger irritant reactions after exposure.

Stinging may occur in the nasolabial folds and on cheeks after an irritant is applied. Frosch and Kligman reported that the most "stingers" were light-complexioned persons of Celtic ancestry who sunburned easily and tanned poorly (29). Later, however, Grove et al. found no skin-type propensity to stinging; they applied 10% lactic acid to the nasolabial folds and cheek of volunteers and noted that increased stinging was related mainly to the person's history of sensitivity to soaps, cosmetics, and drugs (30).

Jourdain et al. (31) have performed an epidemiological survey aimed to assess ethnic variations in self-perceived sensitive skin. They included four ethnic groups: Afro-Americans, Euro-Americans, Hispanics, and Asians. Fifty-two percent of the women declared to have sensitive facial skin but the prevalence of self-reported sensitive skin was alike in all ethnicities. Among the sensitive skin subpopulation, some slight differences between ethnic groups have been noted concerning the cause of irritation or sensitization. Euro-Americans showed higher reactivity to environmental stimuli such as cold and wind and less reactivity to cosmetics, whereas Afro-Americans reacted less to environmental factors and Asians tended to react to wind, spices, and alcohol.

Kaidbey and Kligman studied race-dependent cutaneous reactivity to topical coal (32). There was a strikingly different response in the two groups: in whites, the response was primarily inflammatory, with development of papules and papulopustules in about 2 or 3 weeks, whereas in blacks the inflammatory response was largely absent and, after about 14 days, an eruption of small open comedones appeared. The follicles of white subjects responded early, with rupture of the wall and outpouring of follicular contents in the dermis, whereas in blacks, the first response was proliferative with production and retention of horny cells. That is, in blacks, the skin reacts to a comedogenic compound with hyperkeratoses rather than with disintegration of follicles, suggesting a greater resistance to irritants.

Conflicting findings have been reported on the incidence of allergic contact dermatitis in blacks. Kenney reported a decreased rate (5% in black patients) (33). Marshall and Heyl reported that the incidence of industrial contact dermatitis in South Africa is less in darkly pigmented blacks (34). Dogliotti showed a 7.4% prevalence among Bantus (35). Scott noted that contact dermatitis was less frequent in Bantus handling detergents, waxes, and fuels (36). Despite a previous report describing

an increased sensitization rate in whites, Kligman and Epstein found no significant difference in the two races after testing many topical materials (37). Fisher reported an approximately equal incidence of contact dermatitis in blacks and whites (38). Paraphenylenediamine, nickel, and potassium dichromate appeared to be the most common allergens.

In Nigeria, nickel was the most frequent sensitizer, with an incidence of 12.3% (39) compared with 11% in North America. In Lagos, the female-male ratio is 1:1, whereas Fregert et al. recorded a ratio of 6:1 (40). In North America, the ratio is 3:1 and in Stockholm, it is 7:3.

Clinically, acute contact dermatitis with exudation, vesiculation, or bullae is more common in whites, whereas blacks more commonly develop disorders of pigmentation and lichenification. Hypopigmentation has been described from contact with phenolic detergents (41), alkyl phenols, and monobenzylether of hydroquinone (42).

### Acne

Acne vulgaris is believed to be one of the most frequent dermatologic disorders in ethnic patients. Although the acne pathophysiology is the same in all ethnicities, the most dramatic difference between black and white skin is the higher incidence of post-inflammatory hyperpigmentation (PIH) and keloidal scarring as a result of inflammatory reaction. Hyperpigmentation occurs as darkly pigmented spots or macules that may persist for months or years after the resolution of acne lesions (43). Therefore, on account of the elevated risk of important acne sequelae that influence quality of life, clinicians may have recourse to more aggressive therapies to treat acne in ethnic skin and thereby limit its negative consequences.

The high rate of PIH has been confirmed in a recent study including black, Hispanic, and Asian patients (44). PIH can derive from both acne lesions such as inflammatory papule or pustules or comedones and skin irritation due to topical or systemic therapy.

Keloidal scarring is also considered more frequent in ethnic skin than in white patients, with an incidence that can be between 5 and 16 times higher (45).

Furthermore, in treating acne in ethnic skin, dermatologists must always assess the cosmetic habits and the use of some over-the-counter (OTC) products. In particular, almost half of acne African American patients regularly apply greasy hair moisturizers. This custom leads to a special form of acne, the so-called "pomade-acne" (46). This eruption, consisting mainly of comedones on the forehead and temporal area, seems to be a peculiar response of black skin to topical agents, because this reaction can be detected in black children from 1 to 12 years of age (47). Plewig et al. examined 735 blacks and found that 70% of long-term users of pomades had a form of acne (48). The more elaborate formulations induced pomade acne more frequently and more intensively than simpler preparations such as mineral oil and petroleum jelly. The distribution of the lesions corresponded to the area of contact. Comparable data for whites are lacking.

According to the previously outlined problems, acne treatment in dark skin requires a delicate balance between aggressive and nonirritating therapy. Topical retinoids are considered the first choice therapy as they act either on the acne itself or on PIH (49,50). To reduce their irritating side effect, it is advisable to start with a low concentration or with alternate-day dosing and choose a cream rather than a gel

formulation. Among retinoids, adapalene 1% cream or gel has been reported to be effective and well tolerated even in patients with dry or sensitive skin (51). Once-daily tazarotene 0.1% cream has also shown to improve acne and PIH in blacks (52). Concerning nonretinoid acne topical, azelaic acid is often prescribed because of its low potential of irritation and bleaching effect (53,54).

Severe forms of acne require early employ of systemic isotretinoin (55). Skin dryness is the most common side effect of the treatment and may itself result in PIH but can easily be corrected by regular application of emollients.

### Post-inflammatory Hyperpigmentation

After acne is under control, therapy can be focused on PIH. Hydroquinone remains the gold standard for PIH treatment. Its effectiveness is related to its concentration and the stability of the preparation (56). The OTC products available, usually already used by ethnic patients at time of presentation, contain 1% to 2% hydroquinone but are often ineffective. In clinicians' prescriptions, the concentration varies from 3% to 5%, compounded in cold cream or hydroalcoholic base. It is normally applied once daily and results are appreciable after 4 to 8 weeks of therapy, and optimal effects are observed after 6 to 10 weeks of therapy. Hydroquinone is usually combined with other proximate principles, exploiting the synergistic action of each compound. Hydroquinone 5% with tretinoin 0.1% and dexamethasone 0.1%, known as the Kligman formulation, represents the most famous association. As long-term use of this preparation may determine skin atrophy, telangiectasia, erythema, rosacea-like acneiform eruptions, increased growth of vellus hair, and perioral dermatitis; FDA has approved a modified combination of the Kligman formulation, containing hydroquinone 4%, tretinoin 0.05%, and fluocinonide acetate 0.01%. This association has proved its efficacy without significant side effects in multicentric safety study (57).

Irritation is the most common acute complication, but hydroquinone may also induce infrequent allergic reactions, PIHs, and transient hypochromia. Chronic adverse events consist of leukomelanoderma en confetti, exogenous ochronosis, and nail discoloration; they are usually related to prolonged use of formulations containing high concentrations of hydroquinone (56).

Beside OTC bleaching products, ethnic people still employ traditional drugs, transferred from generation to generation. An interesting recent screening of some of these compounds, used by Nepalese people to treat acquired pigmentation disorders, has been performed by Adhikari et al. (58). They have found 53 crude drugs, 52 were plant extract, 1 derived from a shell called *Cypraea moneta*. All the products tested for the tyrosinase inhibitory activity showed some efficacy. Extracts of roots of *Glycyrrhiza glabra*, leaves of *Morus alba*, flowering bud of *Syzygium aromaticum*, fresh peel of *Citrus aurantifolia*, shell of *C. moneta*, seed of *Punica granatum*, and fresh peel of *Citrus aurantium* demonstrated the higher activity, some with more than 50% inhibition.

### Exogenous Ochronosis

Exogenous ochronosis is a bluish-black pigmentation of connective tissue in the area treated with hydroquinone. The pathogenesis is unknown, but it has been supposed that it derives from the accumulation and polymerization of homogentisic acid (HGA) resulting from the inhibition of its oxidase by hydroquinone. In particular, pigmentation may be induced by

the binding of HGA to fibrillar collagen. Exogenous ochronosis can occur in pigmented skin as a consequence of the use of some topical compounds such as pyric acid, phenol, resorcinol, and hydroquinone. Usually, when induced by hydroquinone (which is a phenolic compound similar to HGA), the discoloration appears within few months of application (59). In the U.S. population, the condition has been described to appear in pigmented skin (blacks and Hispanics) after use of topical hydroquinone at concentrations of 2% or higher for months or years and who have failed to observe sun protection. In these subjects, hydroquinone was applied continuously as a bleaching agent to treat dark pigmentation or dark skin discoloration such as melasma or post-inflammatory pigmentation (60). Nevertheless, exogenous ochronosis is not so frequent in the United States such as in some African populations and countries. This appears to be due to the high concentrations of hydroquinone available in skin-lightening products prior to 1984 in South Africa (average 6–8%) (61). Other compounds capable to induce irreversible depigmentation such as *tert*-butyl alcohol and mercury were included in skin care products in South Africa up to 1986. Resorcinol, used in some African countries in cosmetic products for acne, has been also related to the onset of exogenous ochronosis. Hydroquinone and resorcinol are also used simultaneously to achieve a faster depigmentation (61). Furthermore, alcoholic lotions and vehicle used in lightening and acne products can increase the percutaneous absorption of hydroquinone (62).

From a clinical point of view exogenous ochronosis can be classified in three stages (63):

- Stage I involves erythema and mild pigmentation of the face and the neck.
- Stage II is characterized by appearance of papules and mottled pigmentation.
- Stage III includes papulonodules and inflammation.

While low concentrations of hydroquinone inhibit tyrosinase, higher ones can increase melanin synthesis apparently as consequence of tyrosinase stimulation (64). Melanocytes can be involved in the process of ochronosis since it does not appear in areas affected by vitiligo. The role of sun-exposure is still debated as well (65). Indeed, the condition is often limited to sun-exposed areas.

The treatment of exogenous ochronosis is difficult. Generally, it tends to resolve slowly after stopping the drug. Avoidance of exposure to the causative agent may improve the condition; chemical peels, cryotherapy, and retinoic acid have been used with poor results.

### SUN PROTECTION

As mentioned previously, different skin colors are due to the adaptation to different intensity of sun irradiation that changes with latitude. In the late 1970s, Kaidbey et al. (66) have already demonstrated that 5.7% of UVB are transmitted into the dermis in blacks as opposed to the 29.4% in whites. 17.5% of UVA reaches the upper dermis in blacks whereas in whites 55.5% penetrates. Antoniou et al. (67) have investigated the optical transmission properties of different skin types, demonstrating that, as expected, skin of color is naturally better protected against damage caused by UVA and also against visible and red range of the spectra. They conclude that, because of the different relation between UVA and UVB protection among skin types, specific sunscreens should be developed.

## CHEMICAL PEELING

As underlined by Roberts (68), chemical peeling was first employed precisely by people of color. Cleopatra's habit to bath in sour milk can be correctly considered an early employment of  $\alpha$ -hydroxy acids as an exfoliating agent.

In ethnic patients, chemical peeling is useful especially for the management of pigmentary disorders such as PIH, solar lentigines, mottled dyschromia, and melasma. Acne vulgaris, scarring, and pseudofolliculitis barbae represent other significant indications (68).

### Acne

Among  $\alpha$ -hydroxy acids, glycolic acid is the one most frequently used. Its application on the skin induces epidermolysis in a few minutes. Concentration and vehicle are both important to modulate peeling intensity as well as the amount of acid delivered and the method of application. To reduce side effects, partially buffered glycolic acid is recommended (69). Concentration varies from 30% to 70%. It has shown to be effective and safe for the treatment of acne in ethnic skin (70).

Chemical peeling with a 20% to 30% liquid salicylic acid solution improves acne with a good safety profile (71).

### PIH

PIH may benefit from glycolic or salicylic acid peeling. TCA 25% and Jessner's solution have been used successfully. A full face peeling or alternatively a "spot peel" can be performed. Spot peel is recommended using TCA 25% and Jessner's solution. Improvement is perceptible after three to six peeling sessions. Patient should always have been pretreated with topical skin-lightening agents prior to peeling, and topical therapy should be continued for about four to eight weeks (68).

### Melasma

Melasma is a common complaint of patients with skin of color, especially Asians, fair-complected African Americans, and Hispanics women. Once possible causative factors have been screened, sunscreens, topical hydroquinone, and chemical peels remain the treatments of choice. Among available chemical peels, glycolic acid and salicylic acid represent a good tool to reduce epidermal pigmentation in melasma in ethnic skin. Asians and Asian Americans respond better to glycolic peels (72) than to salicylic ones whereas the opposite occurs in blacks. Pre- and posttreatment with topical bleaching agents is advisable as well as daily UV protection.

### Acne Scarring

Nonhypertrophic acne scarring may be improved with a series of combined peels with 70% glycolic acid gel and 25% TCA. Seventy percent glycolic gel is first applied followed by 25% TCA; at the beginning of the frosting, the peel is neutralized with a sodium bicarbonate solution (68).

### Pseudofolliculitis Barbae

Excellent results are obtained treating pseudofolliculitis barbae with series of glycolic or salicylic peels (68).

### Solar Lentigines and Mottled Pigmentation

As in fair complexions, solar lentigines and mottled pigmentation are a manifestation of aging. Spot peel with a 25% TCA, applied until a white frost is achieved, represents a good

therapeutic option for solar lentigines in ethnic skin. Mottling is improved by series of 50% to 70% glycolic acid peels or by 20% to 30% salicylic acid peels (68).

## SKIN AGING AND REJUVENATION

### Skin Aging

Thanks to progress in in vivo imaging modalities such as ultrasound (US) and optical coherence tomography (OCT), differences between ethnicities concerning skin structure have been recently better investigated. With a 25 MHz US imaging system, it is possible to measure skin thickness and the subepidermal nonechogenic band (SENEB) that depends on skin aging. On the other side, OCT imaging supplies a description of epidermis morphology. Querleux et al. (73) have reported interesting data. On the basis of OCT measurements, their study has demonstrated that epidermis thickness, taken at the top of the papillae, does not change with age in all ethnic groups, whereas (DEJ) is influenced by aging process and flattens. This phenomenon concerning the DEJ is accentuated in Caucasians compared to blacks. It is therefore deducible that blacks show signs of aging later than whites. This data is confirmed by the measurement of SENEb by means of US imaging at 25 MHz; SENEb is thinner in African Americans than in Caucasians.

In blacks, photoaging appears unusually before the sixth decade. Mottled pigmentation, fine wrinkling, laxity, and dermatosis papulosa nigra represent the most common manifestations of photoaging in African Americans (74).

In Asians, due to their geographic position, photoaging is frequent, especially in East Asians whose skin color is quite light. Feature of photoaging in East Asians are mainly seborehmic keratosis and wrinkling (74).

### Nonablative Photorejuvenation

As ablative resurfacing implies high risk of serious and prolonged side effects in ethnic skin such as PIH, scarring, and postinflammatory hypopigmentation, the choice of nonablative devices is advisable (75). Wherever using visible and near-infrared lasers or light devices, efficient cooling is fundamental to avoid thermal injury.

532 nm has been used for rejuvenation in ethnic skin with improvement of erythema, texture, pigmentation, and wrinkling (76,77). Low incidences of hyperpigmentation and hypopigmentation have been reported.

Successful rejuvenation, without side effects, has been obtained by Trelles et al. (78) using combination of 595 and 1450 nm lasers.

Different authors have described the use of IPL in ethnic skin. Excellent results have been achieved employing a 550 nm cutoff filter (79,80) or a 640 nm cutoff filter.

Recently, perioral and periocular rhytids as well as neck and forehead rhytids have been treated with a 1540 nm erbium: glass laser in patients with type IV skin. Clinical improvement was also confirmed by US imaging and digital profilometry; the procedure has demonstrated an excellent safety profile (81).

Light emitting diodes (LEDs), fractional photothermolysis, and radiofrequency represent new nonablative devices for rejuvenation.

LEDs light therapy has been approved by FDA. It has been established that specific wavelengths of visible red and infrared light emitted by LEDs stimulate fibroblastic activity and the release of adenosine triphosphate (ATP), boost collagen production, diminish hyperpigmentation, induce formation of

new capillaries, and increase lymphatic system activity. In skin type IV, clinical results have been excellent, and there were no reported adverse effects (82,83).

Fractional photothermolysis is delivered by a nonablative erbium:glass laser (1500 nm) and consists in microscopic columns of thermal damage (84). It is an FDA-approved device for treating pigmented lesions, periorbital rhytides, skin resurfacing, and melasma. As epidermis is protected from injury and melanin is not a target of this type of laser, fractional photothermolysis possesses the suitable features to be used in skin of color. Indeed, the procedure has been described as safe and effective for treating photoaging as well as acne scarring in ethnic patients (85).

Together with photoaging, skin laxity is an important sign of advanced age and it is common in all skin types. The demand of an effective treatment for skin laxity is increasing. Patients with skin of color seek for nonsurgical procedures because of their proneness of scarring. Radio frequency (RF) is electromagnetic radiation in the frequency range of 3 kHz to 300 GHz. It works by selectively delivering heat energy to the dermis, thus inducing collagen remodeling and contraction. In their study performed on Asian patients, Kushikata et al. (86) concluded that RF represents an effective and safe tool to achieve skin tightening in skin of color.

## REFERENCES

- Berardesca E, Maibach H. Racial differences in skin pathophysiology. *J Am Acad Dermatol* 1996; 34:667-672.
- Parvez S, Kang M, Chung HS, et al. Survey and mechanism of skin depigmenting and lightening agents (review). *Phytother Res* 2006; 20(11):921-934.
- Antoniou C, Lademan J, Richter H, et al. Analysis of the melanin distribution in different ethnic groups by in vivo laser scanning microscopy. *Laser Phys Lett* 2009; 6(5):393-398.
- Rawlings AV. Ethnic skin types: are there differences in skin structure and function? *Int J Cosmet Sci* 2006; 28(2):79-93.
- Freeman RG, Cockerell EG, Armstrong J, et al. Sunlight as a factor influencing the thickness of epidermis. *J Invest Dermatol* 1962; 39:295-297.
- Thomson ML. Relative efficiency of pigment and horny layer thickness in protecting the skin of European and Africans against solar ultraviolet radiation. *J Physiol (Lond)* 1955; 127:236.
- Weigand DA, Haygood C, Gaylor JR. Cell layers and density of Negro and Caucasians stratum corneum. *J Invest Dermatol* 1974; 62:563-565.
- Rienertson RP, Wheatley VR. Studies on the chemical composition of human epidermal lipids. *J Invest Dermatol* 1959; 32:49-51.
- Johnson LC, Corah NL. Racial differences in skin resistance. *Science* 1963; 139:766-769.
- Corcuff P, Lotte C, Rougier A, et al. Racial differences in corneocytes. A comparison between black, white and oriental skin. *Acta Derm Venereol* 1991; 71:146-148.
- Warrier AG, Kligman AM, Harper RA, et al. A comparison of black and white skin using non invasive methods. *J Soc Cosmet Chem* 1996; 47:229-240.
- Fotouh C, Elkhyat A, Mac S, et al. Cutaneous differences between Black, African or Caribbean Mixed-race and Caucasian women: biometrological approach of the hydrolipidic film. *Skin Res Technol* 2008; 14(3):327-335.
- Sugino K, Imokawa G, Maibach H. Ethnic difference of stratum corneum lipid in relation to stratum corneum function. *J Invest Dermatol* 1993; 100:597.
- Kompaore F, Marty JP, Dupont Ch. In vivo evaluation of the stratum corneum barrier function in Blacks, Caucasians and Asians with two noninvasive methods. *Skin Pharmacol* 1993; 6:200-207.
- Wilson D, Berardesca E, Maibach HI. In vitro transepidermal water loss: differences between Black and white human skin. *Br J Dermatol* 1988; 199:647-652.
- Berardesca E, Maibach HI. Racial differences in sodium lauryl sulphate induced cutaneous irritation: black and white. *Contact Dermatitis* 1988; 18:136-140.
- Yosipovitch G, Theng CTS. Asian skin: its architecture, function, and differences from caucasian skin. *Cosmet Toiletr* 2002; 117(9): 57-62.
- Reed JT, Ghadially R, Elias PM. Effect of race, gender and skin type on epidermal permeability barrier function. *J Invest Dermatol* 1994; 102:537.
- Berardesca E, de Rigal J, Leveque JL, et al. In vivo biophysical characterization of skin physiological differences in races. *Dermatologica* 1991; 182:89-93.
- Baker H. The skin as a barrier. In: Rook A, ed. *Textbook of Dermatology*. Oxford: Blackwell Scientific, 1986:355.
- Reed JT, Ghadially R, Elias PM. Skin type, but neither race nor gender, influence epidermal permeability function. *Arch Dermatol* 1995; 131(10):1134-1138.
- Berardesca E, Pirot F, Singh M, et al. Differences in stratum corneum pH gradient when comparing white Caucasian and Black African-American skin. *Br J Dermatol* 1998; 139:855-857.
- Berardesca E, Maibach HI. Sodium lauryl sulphate induced cutaneous irritation. Comparison of white and Hispanic subjects. *Contact Dermatitis* 1988; 19:136-140.
- Rietschel RL. A method to evaluate skin moisturizers in vivo. *J Invest Dermatol* 1978; 70:152-155.
- Quinton PM, Elder HY, Jenkinson DME, et al. Structure and function of human sweat glands In: Laden K, ed. *Antiperspirants and Deodorants*. New York: Marcel Dekker, 1999:17-58.
- Marshall EK, Lynch V, Smith HV. Variation in susceptibility of the skin to dichloroethylsulfide. *J Pharmacol Exp Ther* 1919; 12:291-301.
- Weigand DA, Mershon GE. The cutaneous irritant reaction to agent O-chlorobenzylidene malonitrile (CS). Quantitation and racial influence in human subjects. February 1970 Edgewood Arsenal Technical Report 4332.
- Weigand DA, Gaylor JR. Irritant reaction in Negro and Caucasian skin. *South Med J* 1974; 67:548-551.
- Frosh P, Kligman AM. A method for appraising the stinging capacity of topically applied substances. *J Soc Cosmet Chem* 1981; 28:197.
- Grove GL, Soschin DM, Kligman AM. Adverse subjective reactions to topical agents. In: Drill VA, Lazar P, eds. *Cutaneous Toxicology*. New York: Raven Press, 1984.
- Jourdain R, de Lacharrière O, Bastien P, et al. Ethnic variations in self-perceived sensitive skin: epidemiological survey. *Contact Dermatitis* 2002; 46(3):162-169.
- Kaidbey KH, Kligman AM. A human model for coal tar acne. *Arch Dermatol* 1974; 109:212-215.
- Kenney J. Dermatoses seen in American Negroes. *Int J Dermatol* 1970; 9:110-113.
- Marshall J, Heyl T. Skin diseases in the Western Cape Province. *S Afr Med J* 1963; 37:1308.
- Dogliotti M. Skin disorders in the Bantu: a survey of 2000 cases from Baragwanath Hospital. *S Afr Med J* 1970; 44:670.
- Scott F. Skin diseases in the South African Bantu. In: Marshall J, ed. *Essays on Tropical Dermatology*. Amsterdam: Excerpta Medica, 1972.
- Kligman AM, Epstein W. Updating the maximization test for identifying contact allergens. *Contact Dermatitis* 1975; 1:231.
- Fisher AA. Contact dermatitis in black patients. *Cutis* 1977; 20: 303-320.
- Olumide YM. Contact dermatitis in Nigeria. *Contact Dermatitis* 1985; 12:241-246.
- Fregert S, Hjorth N, Magnusson B, et al. Epidemiology of contact dermatitis. *Trans St John's Hosp Dermatol Soc* 1969; 55:17.
- Fisher AA. Vitiligo due to contactants. *Cutis* 1976; 17:431-437.

42. Kahn G. Depigmentation caused by phenolic detergent germicides. *Arch Dermatol* 1970; 102:177-187.
43. Taylor S. Cosmetic problems in skin of color. *Skin Pharmacol Appl Skin Physiol* 1999; 12:139-143.
44. Taylor SC, Cook-Bolden F, Rahman Z, et al. Acne vulgaris in skin of color (review). *J Am Acad Dermatol* 2002; 46(2 suppl understanding):S98-S106.
45. Kelly AP. Keloids: pathogenesis and treatment. *Cosmet Dermatol* 2003; 16:28-32.
46. Kligman AM, Mills OH. Acne cosmetic. *Arch Dermatol* 1972;106:843-850.
47. Verhagen AR. Pomade acne in black patients. *Arch Dermatol* 1974; 110:465.
48. Plewig G, Fulton JE, Kligman AM. Pomade acne. *Arch Dermatol* 1970; 101:580.
49. Halder RM. The role of retinoids in the management of cutaneous conditions in blacks (review). *J Am Acad Dermatol* 1998; 39(2 pt 3): S98-S103.
50. Shalita AR, Chalker DK, Griffith RF, et al. Tazarotene gel is safe and effective in the treatment of acne vulgaris: a multicenter, double-blind, vehicle-controlled study. *Cutis* 1999; 63(6):349-354.
51. Czernielewski J, Poncet M, Mizzi F. Efficacy and cutaneous safety of adapalene in black patients versus white patients with acne vulgaris. *Cutis* 2002; 70(4):243-248.
52. Grimes PE, Callender VD. Tazarotene cream 0.1% in the treatment of facial post-inflammatory hyperpigmentation associated with acne vulgaris: a two-center, double-blind, randomized, vehicle-controlled study. Poster presented at the 61st Annual Meeting of the American Academy Dermatology, San Francisco, CA, March 2003:21-26.
53. Perez A, Sanchez JL. Treatment of acne vulgaris in skin of color. *Cosmet Dermatol* 2003; 16:23-28.
54. Nguyen QH, Bui TP. Azelaic acid: pharmacokinetic and pharmacodynamic properties and its therapeutic role in hyperpigmentation disorders and acne (review). *Int J Dermatol* 1995; 34(2):75-84.
55. Kelly AP, Sampson DD. Recalcitrant nodulocystic acne in black Americans: treatment with isotretinoin. *J Natl Med Assoc* 1987; 79(12):1266-1270.
56. Picardo M, Carrera M. New and experimental treatments of cloasma and other hypermelanoses (review). *Dermatol Clin* 2007; 25(3):353-362, ix.
57. Torok H, Taylor S, Baumann L, et al. A large 12-month extension study of an 8-week trial to evaluate the safety and efficacy of triple combination (TC) cream in melasma patients previously treated with TC cream or one of its dyads. *J Drugs Dermatol* 2005; 4(5): 592-597.
58. Adhikari A, Devkota HP, Takano A, et al. Screening of Nepalese crude drugs traditionally used to treat hyperpigmentation: in vitro tyrosinase inhibition. *Int J Cosmet Sci* 2008; 30(5):353-360.
59. Levin CY, Maibach H. Exogenous ochronosis. An update on clinical features, causative agents and treatment options (review). *Am J Clin Dermatol* 2001; 2(4):213-217.
60. Touart D, Sau P. Cutaneous deposition diseases. Part II. *J Am Acad Dermatol* 1998; 39:527-544.
61. Burke P, Maibach H. Exogenous ochronosis: an overview. *J Dermatol Treat* 1997; 8:21-26.
62. Bucks D, McMaster J, Guy R, et al. Percutaneous absorption of hydroquinone in humans: effect of 1-dodecylazacycloheptan-2-one (azone) and the 2-ethylhexylester of 4-(dimethylamino)benzoic acid (Escalol 507). *J Toxicol Environ Health* 1988; 24:279-289.
63. Dogliotti M, Leibowitz M. Granulomatous ochronosis: a cosmetic-induced skin disorder in blacks. *S Afr Med J* 1979; 56:757-760.
64. Chen Y, Chavin W. Hydroquinone activation and inhibition of skin tyrosinase. In: Riley V, ed. *Proceedings of the 9th International Pigment Cell Conference*. New York: Karger, 1976:105-112.
65. O'Donoghue M, Lynfield Y, Derbes V. Ochronosis due to hydroquinone. *J Am Acad Dermatol* 1983; 8:123-125.
66. Kaidbey KH, Agin PP, Sayre RM, et al. Photoprotection by melanin—a comparison of black and Caucasian skin. *J Am Acad Dermatol* 1979; 1(3):249-260.
67. Antoniou C, Lademann J, Schanzer S, et al. Do different ethnic groups need different sun protection? *Skin Res Technol* 2009; 15(3): 323-329.
68. Roberts WE. Chemical peeling in ethnic/dark skin (review). *Dermatol Ther* 2004; 17(2):196-205.
69. Becker FF, Langford FP, Rubin MG, et al. A histological comparison of 50% and 70% glycolic acid peels using solutions with various pHs. *Dermatol Surg* 1996; 22(5):463-465.
70. Wang CM, Huang CL, Hu CT, et al. The effect of glycolic acid on the treatment of acne in Asian skin. *Dermatol Surg* 1997; 23(1):23-29.
71. Grimes PE. The safety and efficacy of salicylic acid chemical peels in darker racial-ethnic groups. *Dermatol Surg* 1999; 25(1):18-22.
72. Javaheri SM, Handa S, Kaur I, et al. Safety and efficacy of glycolic acid facial peel in Indian women with melasma. *Int J Dermatol* 2001; 40(5):354-357.
73. Querleux B, Baldeweck T, Diridollou S, et al. Skin from various ethnic origins and aging: an in vivo cross-sectional multimodality imaging study. *Skin Res Technol* 2009; 15(3):306-313.
74. Munavalli GS, Weiss RA, Halder RM. Photoaging and nonablative photorejuvenation in ethnic skin. *Dermatol Surg* 2005; 31(9 pt 2): 1250-1260; discussion 1261.
75. Cho SI, Kim YC. Treatment of atrophic facial scars with combined use of high-energy pulsed CO<sub>2</sub> laser and Er:YAG laser: a practical guide of the laser techniques for the Er:YAG laser. *Dermatol Surg* 1999; 25(12):959-964.
76. Lee MW. Combination 532-nm and 1064-nm lasers for noninvasive skin rejuvenation and toning. *Arch Dermatol* 2003; 139(10): 1265-1276. Erratum in: *Arch Dermatol* 2004; 140(5):625.
77. Rashid T, Hussain I, Haider M, et al. Laser therapy of freckles and lentiginos with quasi-continuous, frequency-doubled, Nd:YAG (532 nm) laser in Fitzpatrick skin type IV: a 24-month follow-up. *J Cosmet Laser Ther* 2002; 4(3-4):81-85.
78. Trelles MA, Allones I, Levy JL, et al. Combined nonablative skin rejuvenation with the 595- and 1450-nm lasers. *Dermatol Surg* 2004; 30(10):1292-1298.
79. Negishi K, Tezuka Y, Kushikata N, et al. Photorejuvenation for Asian skin by intense pulsed light. *Dermatol Surg* 2001; 27(7):627-631; discussion 632.
80. Negishi K, Wakamatsu S, Kushikata N, et al. Full-face photorejuvenation of photodamaged skin by intense pulsed light with integrated contact cooling: initial experiences in Asian patients. *Lasers Surg Med* 2002; 30(4):298-305.
81. Fournier N, Dahan S, Barneon G, et al. Nonablative remodeling: a 14-month clinical ultrasound imaging and profilometric evaluation of a 1540 nm Er:Glass laser. *Dermatol Surg* 2002; 28(10):926-931.
82. Weiss RA, Weiss MA, Geronemus RG, et al. A novel non-thermal non-ablative full panel LED photomodulation device for reversal of photoaging: digital microscopic and clinical results in various skin types. *J Drugs Dermatol* 2004; 3(6):605-610.
83. Weiss RA, McDaniel DH, Geronemus RG, et al. Clinical trial of a novel non-thermal LED array for reversal of photoaging: clinical, histologic, and surface profilometric results. *Lasers Surg Med* 2005; 36(2):85-91.
84. Manstein D, Herron GS, Sink RK, et al. Fractional photothermolysis: a new concept for cutaneous remodeling using microscopic patterns of thermal injury. *Lasers Surg Med* 2004; 34(5):426-438.
85. Hu S, Chen MC, Lee MC, et al. Fractional resurfacing for the treatment of atrophic facial acne scars in Asian skin. *Dermatol Surg* 2009; 35(5):826-832 [Epub April 6, 2009].
86. Kushikata N, Negishi K, Tezuka Y, et al. Non-ablative skin tightening with radiofrequency in Asian skin. *Lasers Surg Med* 2005; 36(2):92-97.



## Ethnic variation in hair

Nina Otberg

### INTRODUCTION

The diversity of human skin types and its appendages is a result of various stages of evolution, climate changes, and migration. Studying the complexity of ethnic variations in human hair and skin is not only interesting from an anthropological point of view but certainly of interest for the dermatologist as well as for the cosmetic and pharmaceutical industry.

Classifying different ethnic groups is particularly difficult because ancient or more recent migration processes and mixes between ethnic groups or subgroups are usually not taken into account.

Many studies have broadly distinguished three ethnic human subgroups: African, Asian, and Caucasian. Such a broad classification cannot account for the great complexity of human biological diversity, resulting from multiple, past, or recent mixed origins.

The term African refers to people who live in Africa or people who trace their ancestry to indigenous inhabitants of Africa. This includes people who were displaced in the African diaspora resulting from the Atlantic slave trade such as African Americans, African Canadians, Afro-Latin Americans, Afro-Caribbeans, and Black British. The term black people is often used as a synonym for people of African ancestry (in particular Sub-Saharan Africa). The term Asian refers most commonly to people of predominantly East Asian and Southeast Asian ancestry. The term Caucasian has been used to characterize the general physical type of some or all of the indigenous populations of Europe; North Africa; and western, south, and middle Asia (1). The concept of a Caucasian, Asian, or African race is highly controversial today. It is rejected by many academics and political activists who view any system of categorizing humanity on the basis of physical type as obsolete (1,2). Responses to drugs and cosmetics can vary dramatically on the basis of ethnicity. There is a great debate as to whether ethnic categorizations as broad Caucasian, Asian, and African are medically valid (3,4).

Nevertheless, since most studies on ethnic hair diversity use this broad and unsatisfactory characterization, this chapter will retain the terms Caucasian, Asian, and African.

### SCALP HAIR

Scalp hair is probably one of our most distinctive features. It represents health, beauty, sexual attraction, and moreover it reflects our personality and individuality. Depending on its structure and physical properties, scalp hair is subject to limitations that will only permit certain styles without major damage to the hair shaft.

Several features of the scalp hair, such as form, color, thickness, density, maximal length, and tensile strength are genetically determined and show great variation between different ethnic groups and subgroups. The understanding of the

diversity of scalp hair and its different response to physical and chemical treatments is the prerequisite for a proper development and application of hair care and is likewise important for the dermatologist, cosmetic scientist, product formulator, and the hair stylist.

### ETHNIC DIVERSITY OF HUMAN SCALP HAIR Hair Shape and Thickness

The term Caucasian or Indo-European comprised a vast diversity of different ethnic subgroups originating from Europe, North Africa, and western (as well as south and middle) Asia. Therefore, this group shows a tremendous variability in hair shaft shape and caliber. In general, Caucasian hair has a slightly flattened or oval cross section with a diameter ranging from 50 to 90  $\mu\text{m}$  (5,6). In Europeans, hair shaft diameters can range from approximately 50 to 120  $\mu\text{m}$  (Otberg, unpublished data). Very fine hair with diameters less than 50  $\mu\text{m}$  is most frequently seen in the Scandinavian population and northwestern Europe (5). Straight Caucasian hair is relatively untwisted along the shaft, whereas wavy or curly hair shows a higher degree of twisting proportional to the degree of curling (5,7–10).

Hair of people originating from East Asia (China, Korea, and Japan) is usually referred to as Oriental or Asian hair. It generally shows the greatest diameter, ranging from 100 to 130  $\mu\text{m}$  (5) (Otberg, unpublished data). Asian hair shafts are straight with no or very few twists along the shaft and with a round cross section (7–9).

Hair of people of Sub-Saharan Africa is highly characteristic in shape. African hair is considerably flattened, grooved, and frequently vary in diameter along one single shaft. It tends to be highly twisted, with random reversal in twist direction. Lindelöf et al. showed that the hair follicle in African hair is spiral in shape. They found that the shape of the hair shaft conformed to the shape of the follicle in all three major ethnic hair types (Caucasian, Asian, and African) (11). African hair can be quite sharply kinked at the edges and is especially vulnerable to damage at such points. The hair of people from different African countries shows great variability in the degree of curling, with eastern African hair showing the least degree of curling (5,12,13). African hair tends to be more easily harmed by cosmetic procedures than cylindrical hair and grooming usually requires more force especially when the hair is dry (5,12,14).

Since the conventional classification of three ethnic subgroups hardly accounts for the great diversity of human hair characteristics, De la Mettrie et al. developed a new approach to classify hair based on physical features. Hair types were defined according to three different hair shape criteria (curve diameter, curl index, and number of waves) without referring to human ethnicity. This method leads to a classification of hair in eight well-defined categories and may be more appropriate

and more reliable than conventional standards in both cosmetic sciences and anthropology (15).

### Hair Density

The appearance of thick full hair depends not only on the number of hairs but certainly on the thickness of the hair shaft, its shape and color, and its contrast to the skin. In general, there is a relationship between the number of hairs (density) and size of the hair shafts (thickness), so that ethnic groups with the thickest caliber hair have the lowest density (i.e., Asians) and those with fine hair have the highest density (i.e., Scandinavians) (16). An average Caucasian brown-haired man is believed to have approximately 100,000 hair follicle on the scalp, while blondes tend to have 20% more, and red heads around 20% less hair (17,18).

Surprisingly, few studies are published on normal scalp hair density. Whiting, Aslani et al., Sperling, Templeton et al., and Lee et al. utilized horizontal sections of scalp biopsies to determine terminal and vellus hair density as well as anagen-telogen ratio in Caucasian, African-American, and Asian patients. Lee et al. showed the lowest hair counts in Asian patients (35 Korean patients) with 1.2 terminal hairs/mm<sup>2</sup> (120/cm<sup>2</sup>) on average (19). Higher counts showing 1.5 terminal hairs/mm<sup>2</sup> (150/cm<sup>2</sup>) were found in 22 African American patients (20). Highest hair counts of 3.1 hairs/mm<sup>2</sup> (310/cm<sup>2</sup>) were found in scalp biopsies of 22 Caucasian men by Whiting (21), Aslani et al. counted 2.8 hairs/mm<sup>2</sup> (280/cm<sup>2</sup>,  $n = 21$ ) in scalp biopsies of male volunteers and slightly lower numbers in women (2.5 hairs/mm<sup>2</sup> = 250/cm<sup>2</sup>,  $n = 9$ ) (22); Templeton et al. found 2.7 terminal hairs/mm<sup>2</sup> (270/cm<sup>2</sup>) (23), and Sperling found 2.5 terminal hairs/mm<sup>2</sup> (250/cm<sup>2</sup>) (20) on average in Caucasian patients. Whiting and Aslani et al. obtained specimens from control subjects with no evidence of alopecia (21,22), whereas Sperling, Templeton et al., and Lee et al. evaluated hair density in specimens from clinically normal occipital scalp of patients with androgenetic alopecia (19,20,23).

Surprisingly, great variation were found in the terminal-vellus hair ratio (T-V ratio) among the different studies. Whiting found a T-V ratio of 1.7:1 (21), whereas Sperling, Lee et al., and Aslani et al. found much higher values [Caucasian: 6.0:1 (20), 17.6:1 (22), Asian 13.5:1 (19), African: 6.1:1 (20)]. Different levels of the horizontal section of the punch biopsy may explain these differences. Vellus hair follicles on the scalp seem to be much smaller compared to vellus hair follicles on the rest of the body. Their infundibulum is located in the very upper part of the dermis; therefore vellus hairs can easily be missed if the horizontal section is evaluated at a deeper level (Otberg, unpublished data).

Noninvasive techniques have also been utilized to determine scalp hair density. One of the earliest methods of measuring hair density was devised by Bouhanna, who used camera attachments to create a "phototrichogram," an ultra close-up photograph of hair exiting the scalp (24). Van Neste combined the phototrichogram with computer-assisted image analysis (25). A further development is the TrichoScan<sup>®</sup> technique introduced by Hoffmann, which combines epiluminescence microscopy with digital image analysis for the measurement of hair density and hair growth parameters (26). Loussouarn et al. confirmed the results for African and Caucasian hair density by using the phototrichogram technique. They found 162 terminal hairs/cm<sup>2</sup> in the occipital area of 106 male volunteers of African descent. Hair density

was highly variable from 90 to 396 hairs/cm<sup>2</sup> and significantly higher on the vertex than on occipital and temporal areas. Women showed a slightly higher hair density in the occipital region than men (167/cm<sup>2</sup> on average,  $n = 110$ ). Vertex and temporal area showed no statistically significant difference between male and female volunteers; the vertex area showed the highest count (M: 188/cm<sup>2</sup>, F: 199/cm<sup>2</sup>); the temporal area showed the lowest values (M: 128/cm<sup>2</sup>, F: 121/cm<sup>2</sup>). Male Caucasian volunteers ( $n = 56$ ) showed an average terminal hair density of 217 hairs/cm<sup>2</sup> in the occipital area, 264/cm<sup>2</sup> in the vertex area, and 151/cm<sup>2</sup> in the temporal area; female Caucasian volunteers showed significantly higher values (occipital: 250/cm<sup>2</sup>, vertex: 308/cm<sup>2</sup>, and temporal: 169/cm<sup>2</sup>) (27). Much higher values compared to Lee et al. were found in the Asian group. Loussouarn et al. measured hair densities in 188 Chinese volunteers. Male Chinese volunteers ( $n = 92$ ) showed 179/cm<sup>2</sup> in the occipital area, 217/cm<sup>2</sup> in the vertex area, and 122/cm<sup>2</sup> in the temporal area; female Chinese volunteers ( $n = 96$ ) showed significantly higher values in the occipital and vertex area (occipital: 185/cm<sup>2</sup>, vertex: 231/cm<sup>2</sup>) and lower values in the temporal area (169/cm<sup>2</sup>) (27). The finding of Loussouarn et al. and Lee et al. indicate the diversity of hair characteristics among different Asian subgroups. Furthermore, the results indicate that sexual difference might have different patterns according to the ethnic background (27).

Jiménez and Poblet used phototrichograms to measure follicular unit (FU) density in the occipital area in patients undergoing hair transplantation. Follicular unit density ranged from 60 to 100 FU/cm<sup>2</sup> with an average hair density of 260 terminal hairs/cm<sup>2</sup>. The authors note that FU density is significantly lower in Asian and African patients. Follicular units tend to maintain a certain distance between each other. This distance correlates with the FU density according to a formula described by Jiménez and Ruiferandez  $L = 10/\sqrt{n}$ , where  $L$  represents the average distance between FUs expressed in millimeters and  $n$  the number of FUs/cm<sup>2</sup> (28,29).

Rassman et al. used a small hand-held magnifier called densitometer to determine hair density and follicular groupings in patients seeking hair restoration surgery. They found that the average hair density and the average follicular unit density vary significantly among different ethnic groups. African American patients showed an average hair density of 1.6 terminal hairs/mm<sup>2</sup> (160/cm<sup>2</sup>) in contrast to Caucasian patients, showing 2.0 hairs/mm<sup>2</sup> (200/cm<sup>2</sup>). In patients of African descent, follicular unit groupings were predominantly found to be in 3s, in Caucasian in 2s and 3s opposed to Asian patients showing follicular units with only 1 to 2 hairs (16).

A more modern noninvasive technique to measure scalp hair density is videodermoscopy (30–32). Videodermoscopy allows evaluating the scalp in 20 to 100-fold magnification; hair and scalp disorders can be easily diagnosed, and when combined with digital image analysis it allows to measure hair density and thickness of the hair shaft without shaving, clipping, or dyeing.

### Hair Growth

Whiting, Aslani et al., Sperling, and Lee et al. found a very similar percentage of terminal anagen and telogen hairs of approximately 94:6 in all three major ethnic groups (Caucasian, Asian, African) (19–22). Lee et al. state that this ratio could be uniformly applied as a normal value in interpreting scalp biopsy specimens regardless of the ethnic background of the

patients (19–22). Loussouarn used the phototrichogram technique to measure hair growth parameters in Caucasian and African men and women (27). Increased telogen counts compared to the data obtained from scalp biopsies were found in both, the African and Caucasian group. The percentage of telogen hair in the vertex area was found to be 17% in African volunteers and 16% in Caucasian group; the occipital area showed 19% of telogen hairs (African) versus 11% (Caucasian). Growth rates were highly variable in both groups with a higher variability and over all lower growth rates in the African group. On average, growth rates of 260  $\mu\text{m}/\text{day}$  (African) versus 397  $\mu\text{m}/\text{day}$  (Caucasian) were found for the vertex area and 252  $\mu\text{m}/\text{day}$  (African) versus 402  $\mu\text{m}/\text{day}$  (Caucasian) for the occipital area (27).

### Hair Color

Hair color is determined mainly by melanin pigmentation within keratinocytes of the hair fiber. Melanin is a complex quinone/indolequinone-derived mixture of biopolymers produced in melanocytes from tyrosine (33). Melanocytes are dendritic neural crest-derived cells that migrate into the epidermis in the first trimester. Hair and epidermal pigmentation are, in so far as melanocytes are concerned, similar processes: in interfollicular skin, melanin, packed in melanosomes, is passed from the melanocytes to the adjacent keratinocytes; in hair, a similar process exists, with pigment being added to the growing keratinocytes (34). Hair melanin is formed by melanocytes situated in the hair bulb epithelium around the upper half of the dermal papilla among cells destined to form the hair cortex. The pigment is donated to cells undergoing early differentiation to form the hair cortex. Melanosomes are also found in the hair medulla, whereas it is unusual to find melanin in the cuticle of human hair shafts (34). Two different types of melanin can be distinguished: eumelanin, which is brown or black, and pheomelanin, which results from the incorporation of cysteine and is yellow or red (35–38). Eumelaninogenic and pheomelaninogenic melanosomes can coexist in the same melanocyte but are produced in different pathways (39–41). The absence or relative absence of both melanin types is associated with white hair, a preponderance of eumelanin, with brown or black hair, and a preponderance of pheomelanin, with red or blond hair.

Since the term Caucasian comprises such a large number of ethnic subgroups, the entire range of hair colors can be found within this group. People of Celtic descent seem to have predominately pheomelanin and therefore reddish brown or blond hair (5), whereas in people originating from southern Europe, North Africa or western, south, or middle Asia, eumelanin is the predominant chromophore and therefore leads to all shades of brown to deep black hair. Asian and African hair is usually densely pigmented with eumelanin and is therefore black or dark brown.

Differences in pigmentation between people are not a result of the number of melanocytes but are largely the result of differences in the amount and types of melanin produced and the macromolecular structure and packaging of melanin. Blond hair appears light because melanosomes are poorly melanized (39). Melanosomes are secreted in different shapes and sizes; such differences change the way of light scattering and thereby the hair color (35).

Furthermore, hair color may vary both in time and site. For example, scalp hair may be blonde in childhood and

become brown or black in adolescence, before becoming white again in middle or old age; beard or pubic hair may be red and the scalp hair black or dark brown in the same individual (35,39,42).

### Hair Biochemistry

Despite the obvious differences in phenotype, hair of different ethnic origin shows relatively little biochemical difference (43). Keratin fiber analysis showed no significant differences in the amino acid composition in Caucasian, Asian, and African hair (9,44). The distribution of cysteine-rich proteins in the hair of volunteers of African descent, Caucasians, and Asian volunteers was found to be similar (45). No ethnic difference was found in the composition of low-sulfur S-carboxymethylated fibrous proteins (9,46,47). However, a difference in the ratio of fibrous protein and matrix protein, with African hair showing a lower ratio of low-sulfur fibrous proteins to high-sulfur matrix proteins compared to Asian and Caucasian hair, was found (47).

### Hair Characteristics

A cross section of fully mature and keratinized human terminal hair reveals three major structures. The central layer is the medulla, the intermediate layer is the cortex, and outermost layer is the cuticle. The medulla consists of a vacuolated, trabecular mass formed from aggregated trichohyalin granules. It contains melanosomes and citrulline-red granules (48). The cortex gives the hair shaft its elasticity and tensile strength. It consists of elongated cells containing tonofilaments and interfilamentous matrix material, which is rich in cysteine. Cortex keratin is different from epithelial keratin, primarily in the increased number of disulfide bonds in the hair shaft. The cuticle forms the protective shield of the hair shaft. It consists of flattened highly keratinized cells arranged like shingles. The scale-like cells overlap tightly in a proximal-to-distal direction along the hair shaft. The cuticle mainly protects the hair shaft from an excessive penetration of water and swelling of the cortex. When the cuticle is intact, the scales are flat and smooth, reflect light, and provide a shiny healthy look to the hair (5,48).

Function and appearance of scalp hair depends on three major characteristics: porosity, elasticity, and texture.

Porosity of the hair measures the ability to allow moisture to pass through the cuticle into the cortex. In a healthy undamaged hair, only minimal amounts of water or other substances can penetrate the cuticle. To allow chemicals to penetrate the hair for permanent waving or hair coloring, which takes place in the hair cortex, the cuticle has to be altered. A higher permeability is achieved by increased temperature or/and by changing the pH of the environment along the shaft. When the processing of the hair is finished, the cuticular scales gradually close again. If processing is too harsh or applied too many times, the cuticle cells cannot return to their original tightness, which results in an imperfect barrier and increased porosity. Increased porosity can also be a result of UV radiation, overheating from flat or curling irons and close, hot blow-drying as well as from excessive combing and teasing (5,48). Highly porous hair tends to be dry and fragile, appears dull, and often contains split ends.

Asian hair is more resistant to chemicals that open the cuticle. Therefore, stronger chemicals are needed if cosmetic alterations are desired such as coloring and permanent waving. African hair, in general, is more fragile and sensitive to chemical alterations. It tends to be drier and since grooming requires

more force, especially in longer African hair, the cuticle is more likely to be damaged (5).

Elasticity is a measure of how far the hair can be stretched without losing the ability to spring back to its original length. Healthy hair can approximately stretch 11/3 of its original length when wet and return to its regular length when dry (48). The tensile strength of the hair shaft is related to its elasticity and is assessing the weight it can support. One healthy hair shaft can support approximately 100 g weight without breaking. Elasticity and tensile strength depend on the hair cortex. Thick, curly hair shows the highest elasticity and tensile strength, whereas thin, straight Caucasian hair shows the least resistance to stretching and the lowest tensile strength.

The third major characteristic is the hair texture. It depends on the diameter and shape of the hair shaft. As discussed earlier, Asian hair shows the thickest diameter and a round, cylindrical shape. Healthy Asian hair is very well suited for long hairstyles; it may become spiky if worn short (Fig. 43.1). African hair is highly twisted with high variability in diameter along the shaft and a flat oval cross section. Therefore, light reflects in different direction, which may result in a dull appearance. African hair is particularly difficult to manage and to remain healthy when worn in longer hairstyles. A tremendous variety in hair texture can be found in Caucasian hair, ranging from very thin cylindrical hair to thick curly hair shafts.

### Hair Care and Styling

Hair care and styling depends on the cultural background and current trends. As discussed earlier, African hair is very different from Asian and Caucasian hair. African hair tends



**Figure 43.1** Spiky appearance of hair in a Chinese man with short haircut. *Source:* Photo courtesy of Dr Jerry Shapiro.

to be very dry, considerable force is needed to comb the hair, and although the hair is susceptible to mechanical damage, African hair can be more easily combed when its wet. Too frequent shampooing will result in excessive dryness and brittleness. It was found that 50% of African American women shampoo once weekly and another third only once every other week (9,49). This is considerably less compared to people of Caucasian or Asian descent. African hair is usually easy to care for when worn short. Oils and pomades are often used to assist in grooming or to treat dry, scaly scalp skin. Braiding is a popular way to manage longer African hair. Artificial braids are often attached to natural braids; classical “cornrow” braids are more frequently seen in children. Tight braids or ponytails may result in prolonged tension on the hair follicle; this may result in traction alopecia and ultimately in permanent hair loss. Today only very few African American women are wearing a natural hairstyle. Many women have their hair regularly straightened. African hair with its tight curls can only be straightened properly by using hot comb procedures or chemical relaxers. Hot combing involves the application of oil to the hair shaft, combing the hair straight with a hot comb (150–250°C) until there are no more curls and then optionally reshaping the hair with large rollers. Chemical relaxers contain either sodium hydroxide or guanidine hydroxide and lithium hydroxide (lye free straighteners). Chemically relaxed hair can also be gently reperm to induce light curls (5,9,48). The use of hot combs and straighteners has been associated with central centrifugal cicatricial alopecia (CCCA), an inflammatory hair loss condition that leads to permanent progressive hair loss, especially on the central parietal scalp (50–52).

Very fine straight Caucasian hair is difficult to style, especially if left to grow much beyond shoulder length. A layered haircut as well as styling products such as volumizing shampoo, mousse, and hair spray can help to create the impression of more volume. Setting straight hair can give waves or curls by temporarily changing the position of the weak hydrogen bonds in the hair shaft by wetting, rearranging, and holding with hair spray. Fine Caucasian hair is especially vulnerable to mechanical damage when it is wet and therefore excessive combing of wet hair should be avoided; less damage is done to the cuticle when the hair is dry. Teasing or backcombing involves combing or brushing the hair toward the root to create small tangles that will hold the hair in place. This procedure was very popular in the 1950s and 1960s to create voluminous hairstyles and the popular beehive style. However, backcombing leads to severe damage of the cuticle and will result in increased porosity and hair breakage. A permanent wave chemically alters the strong disulfide bonds in the hair cortex. Since the hair cortex holds the perm, very fine Caucasian hair may be difficult to perm, because the hair cortex forms a lower proportion of the hair fiber. Thick straight Asian hair is generally difficult to set or perm because it does not flex readily in any preferred direction. Higher concentrations of perming solutions are usually required for Asian hair (5).

The cold wave or base permanent was invented in the 1930s. It involves the application of a solution of ammonium thioglycolate to break the disulfide bonds, after that the hair is neutralized and hardens into a new shape by applying hydrogen peroxide, perborate, or sodium or potassium bromate (48). In the 1970s a more gentle acid-based glycerol monothioglycolate (GMTG) permanent wave was introduced. Glycerol

monothioglycolate separates the cuticular scales to a lesser degree with a lower pH and therefore the cuticle is more likely to return to the original stage after treatment. The acid-based permanent requires heat to be activated. This kind of wave is usually not strong enough to perm very coarse Asian or African hair. A high incidence of contact dermatitis caused by GMTG has been described (48,53).

Changing the color of hair that is heavily pigmented with eumelanin, such as Asian, African, or East-Indian hair is particularly difficult, especially if a much lighter hair color is desired. Bleaching destroys eumelanin and tends to produce red-tinged hair as well as leading to increased weathering and porosity.

### Ethnic Difference in Hair and Scalp Disorders

Ethnic variations in the incidence of *androgenetic alopecia* have been reported. In 1951, Hamilton found that most Chinese retained the frontal hairline after puberty and that baldness was less common, less extensive, and started later in life compared to Caucasians (54). In 1981, Takashima et al. found that Japanese men develop male pattern hair loss approximately 10 years later in life and have a 1.4 times lower incidence in each decade compared to Caucasians (55). Tang et al. investigated the scalp hair of 254 men in Singapore. They found a prevalence of 87% in the East Indian population and 61% in the Chinese population (56). Paik et al. investigated 5531 Korean men. An increase of prevalence with age occurs with an overall prevalence of 14.1% (57). A study carried out on 1124 Chinese and Thai men aged between 18 and 90 years in Bangkok showed a prevalence of 38.5% of male pattern hair loss type III or higher (58). Setty reported that androgenetic alopecia is four times less frequent in men of African origin (59) (Fig. 43.2).

Certain inflammatory hair disorders are more frequently seen in people of African ancestry.

*Pseudofolliculitis barbae* is found in 45% to 83% of African American men who regularly shave (9). *P. barbae* is characterized by perifollicular and follicular papules and pustules as well as scarring in the shaved area. Very kinky hair tends to grow back into the skin surface or pierces the follicular epithelium followed by inflammation when the hair is cut extremely short.

*Dissecting folliculitis* (DF) is also known as *perifolliculitis capitis abscedens et suffodiens* (of Hoffman), *dissecting cellulitis*, *dissecting perifolliculitis*, and *perifolliculitis capitis*. DF is a primary neutrophilic cicatricial alopecia. It manifests with perifollicular pustules, nodules, abscesses and sinuses leading to scarring alopecia. The etiology of dissecting cellulitis is unclear. There are three implicated factors: infection, follicular occlusion, and immune-cell mediated chronic inflammation (60). DF occurs predominantly in black men aged 18 to 40 years (51). It can also occur in men of other ethnicities while women and children are rarely affected (61,62). Chronic and relapsing courses result in cicatricial alopecia that can present as hypertrophic or keloidal scars (63,64).

*Acne keloidalis*, also named *acne keloidalis nuchae*, *dermatitis papillaris capillitii*, or *folliculitis keloidalis*, is a chronic idiopathic, inflammatory process leading to hair loss and hypertrophic scarring in papules and plaques (64). The exact etiology of acne keloidalis is unknown. Probable participating factors include constant irritation from shirt collars, excoriation, and seborrhea, localized infection, shaving of the neck, coarse hair, and autoimmunity (51,65). Acne keloidalis occurs predominantly in black men between 14 and 25 years of age (20). The initial lesions are dome-shaped, firm, skin-colored follicular papules and pustules, which are mostly located on



**Figure 43.2** Young African American women with early female pattern hair loss. *Source:* Photo courtesy of Dr Jerry Shapiro.



**Figure 43.3** African American men with acne keloidalis nuchae displaying keloid-like plaques and pustules. *Source:* Photo courtesy of Dr Jerry Shapiro.

the occipital scalp and the nape of the neck, although they may also be found on the vertex and parietal area (20,66). As the disease progresses, papules and pustules may enlarge and coalesce into keloid-like plaques, associated with variable hair loss (Fig. 43.3).

*Folliculitis decalvans* (FD) is a common form of primary cicatricial alopecia comprising 10.7% to 11.2% of all cases with cicatricial alopecia (67,68). The etiology of folliculitis decalvans remains unclear. It may be a complex combination of a bacterial infection, particularly *Staphylococcus aureus* (*S. aureus*), a hypersensitivity reaction to “superantigens,” and a defect in host cell-mediated immunity regulation (67,69,70). FD predominantly occurs in young and middle-aged adults with a slight preference of the male gender. FD seems to occur more frequently in African Americans compared to Caucasians (67,68). The primary lesions are painful or pruritic follicular pustules or papules (69). With progression, more pustules and papules, as well as crusting and nodules, can be seen. Associated with the inflammatory activity, one or more round to irregular patches of scarring alopecia develop. The patches look like ivory pseudopelade skin centrally with surrounding follicular pustules and crusts at the margins of active lesions (50,71) (Fig. 43.4).

CCCA is a lymphocytic primary cicatricial alopecia that primarily affects African American women. It can rarely be seen in Caucasians (sometimes called “central elliptical pseudopelade”) and African American men: CCCA presents with a patch of scarring alopecia similar to Pseudopelade of Brocq on the central scalp, which slowly progresses centrifugally. It remains unclear if chemical processing, heat, traction, or other traumas contribute to the development of this condition (20,50,52) (Fig. 43.5).

The etiology of cicatricial alopecias is poorly understood. Inflammatory cicatricial alopecias seem to be less frequent in people of Asian ancestry, suggesting that the shape of the follicle and hair shaft plays a role in the pathogenesis.



**Figure 43.4** Caucasian female patient with extensive folliculitis decalvans. *Source:* Photo courtesy of Dr Jerry Shapiro.



**Figure 43.5** African American women with central centrifugal cicatricial alopecia (CCCA). *Source:* Photo courtesy of Dr Jerry Shapiro.

## BODY HAIR

Very little data is available on ethnic difference in body hair. The density in chest hair in men has been reported to be highest in Caucasian especially in those with a darker skin color. Blond Italian man showed denser chest hair compared to Scandinavian men. In general, growth of terminal body hair seems to be more prominent in men of Mediterranean descent compared to Nordic descent (72). Men of African and Asian ancestry were found to have considerably low body hair compared Caucasian men (72). Axillary hair growth in Caucasians were found to be much denser than in Japanese of both sexes (17). Dense terminal hair growth of the external ear or pinna (hypertrichosis pinnae auris) is very commonly seen in men of East Indian descent. 85% of Caucasian men also show some degree of terminal hair growth in this area opposed to 55% of men of African ancestry. The mode of inheritance of this form of Hypertrichosis seems to be Y-linked (73).

Growth of terminal body hair is of concern for most women. However, it is very difficult to decide whether the hair growth is excessive and should be classified as Hirsutism or within the range of normal variation. Hirsutism is highly unusual in Asian women, despite the fact that levels of androgens may even be higher (17).

## Eye Lashes

Na et al. performed a study to determine differences in eyelash shape and growth rate in Asian and Caucasian volunteers. Lateral digital photographs of upper eyelashes were taken and curl-up and lift-up angles of the upper eyelashes were measured from lateral views. Additionally, the phototrichogram technique was used to determine total number, length, and thickness of upper eyelashes. The central portion of the eyelashes or whole eyelashes was clipped and images were taken immediately and seven days later to obtain the growth rate and anagen ratio. The number and thickness of the cuticular layers were measured by electron microscopy. Asian eyelashes revealed lower lift-up and curl-up angles, fewer numbers, and a thicker transverse diameter compared to Caucasian lashes. No statistical difference was found in length or growth rate. The duration of the anagen phase was estimated at about two months. The eyelash anagen rate obtained was approximately 17.8%. The number of cuticular layers was greater in Asians (8.0) than in Caucasians (6.5), but no statistical difference was found in the thickness of a single cuticle layer between the two groups (74). No data is available for African eyelashes. Eyelashes of people of African descent seem to be curlier compared to those of Asians or Caucasians.

## Vellus Hair

Very little is published on the size and distribution of vellus hair. Hwang and Baik obtained skin samples from different body sites of Korean adults to determine the density and distribution of hair follicles and sweat glands. The average hair density was found to be 36/cm<sup>2</sup> on the back, 33/cm<sup>2</sup> on the thorax, 40/cm<sup>2</sup> on the upper arm, 18/cm<sup>2</sup> on the forearm, 28/cm<sup>2</sup> on the thigh and 11/cm<sup>2</sup> on the calf (75). Cyanoacrylate surface biopsies have been utilized to study vellus hair parameters in seven different body sites in Caucasian, Asian, and African American volunteers with comparable height and body mass index (76,77). Hair density, hair shaft diameter, size and surface area of the follicular orifices, and the volume of vellus hair follicles have been measured and calculated on microscopic images in combination with digital image analysis. The highest hair density was found on the forehead; significantly lower densities have been determined on the other body areas (upper arm > back > chest > thigh > forearm > calf). This overall trend was seen in all three ethnic skin types. Significant differences in vellus hair density were found on the forehead with Caucasians, showing the highest average density (292/cm<sup>2</sup>) followed by African American (189/cm<sup>2</sup>) and Asians (138/cm<sup>2</sup>). These differences correlate well with the ethnic differences found for scalp hair density. No significant differences have been found in vellus hair density in the other 6 skin areas. The diameter of the follicular orifice showed the greatest intersite variation on the forehead of Caucasian volunteers, whereas Asian hair follicles on the forehead seemed to be more uniform in size. The percentage of the surface area taken by the follicular orifice was calculated by multiplying the average circle area of the orifice with the hair density per square centimeter. Caucasians showed the highest values in general with the forehead (1.28%) representing the highest percentage of follicular orifices. Hair shaft diameters were found to be the highest on the calf in all three skin types. However, significant differences among the groups were seen with Caucasian showing the thickest hair shaft diameter on average (42 μm), followed by African Americans (22 μm) and Asians (17 μm). Hair shaft

diameters on the forehead, back, chest, upper arm, and forearm were below 20  $\mu\text{m}$  with no significant differences among the ethnic groups; the thigh showed a similar trend like the area on the calf. The differences in follicle size and hair shaft diameter indicate higher androgen sensitivity in Caucasians. This hypothesis corresponds well with the higher incidence of androgenetic alopecia in the Caucasian population.

## CONCLUDING REMARKS

Hair of people of different ethnic ancestry shows great differences in size, shape, and color. The broad distinction between Caucasian, Asian, and African hair can hardly accomplish the great variety and different needs of human hair. A more elaborate distinction as suggested by De la Mettrie et al. seems to be more useful especially for the development of hair care and styling products (15). Ethnic differences in hair are not only found in scalp hair but also in body hair and vellus hair. The shape and size of hair follicles seems to be a pathogenetic factor for the susceptibility to certain scalp and skin disorders. More research is needed to provide more insight into the chemical and structural differences in human hair and into the related clinical problems.

## REFERENCES

- Jackson JP Jr. "In ways unacademical": the reception of Carleton S. Coon's *The Origin of Races*. *J Hist Biol* 2001; 34:247-285.
- Cavalli-Sforza LL, Menozzi P, Piazza A. *The History and Geography of Human Genes*. Vol 1. Princeton, New Jersey: Princeton University Press, 1994.
- Risch N, Burchard E, Ziv E, et al. Categorization of humans in biomedical research: genes, race and disease. *Genome Biol* 2002; 3:2007.
- Jorde LB, Wooding SP. Genetic variation, classification and 'race'. *Nat Genet* 2004; 36:S28-S33.
- Gray J. *Human Hair Diversity*. Vol 1, 1st ed. Oxford: Blackwell Science, 2000.
- Hutchinson PE, Thompson JR. The cross-sectional size and shape of human terminal scalp hair. *Br J Dermatol* 1997; 136:159-165.
- Steggerda M, Seiber HC. Size and shape of head hairs from six racial groups. *J Hered* 1942; 32:315-318.
- Hrdy D. Quantitative hair form variation in several populations. *Am J Phys Anthropol* 1973; 39:7-8.
- Wilborn WS. Disorders of hair growth in African Americans. In: Olsen EA, ed. *Disorders of Hair Growth—Diagnosis and Treatment*. Vol 1, 2 ed. Barcelona: McGraw Hill, 2003:497-517.
- Bernard BA. Hair shape of curly hair (review). *J Am Acad Dermatol* 2003; 48:S120-S126.
- Lindelöf B, Forslind B, Hedblad MA, et al. Human hair form. Morphology revealed by light and scanning electron microscopy and computer aided three-dimensional reconstruction. *Arch Dermatol* 1988; 124:1359-1363.
- Porter CE, Dixon F, Khine CC, et al. The behavior of hair from different countries. *J Cosmet Sci* 2009; 60:97-109.
- Loussouarn G, Garcel AL, Lozano I, et al. Worldwide diversity of hair curliness: a new method of assessment. *Int J Dermatol* 2007; 46:2-6.
- Porter CE, Diridollou S, Holloway Barbosa V, et al. The influence of African-American hair's curl pattern on its mechanical properties. *Int J Dermatol* 2005; 44:4-5.
- De la Mettrie R, Saint-Léger D, Loussouarn G, et al. Shape variability and classification of human hair: a worldwide approach. *Hum Biol* 2007; 79:265-281.
- Rassman WR, Pomerantz M. The art and science of minigrafting. *Int J Aesthet Rest Surg* 1993; 1:27-36.
- Tobin DJ. The biogenesis and growth of human hair. In: Tobin DJ, ed. *Hair in Toxicology - An Important Bio-Monitor*. Vol 1. Cambridge: RSC Publishing, 2005.
- Szabo G. The regional frequency and distribution of follicles in human skin. In: Montagna W, Ellis RA, eds. *The Biology of Hair Growth*. Vol 1. New York: Academic Press, Inc., 1958:33-38.
- Lee HJ, Ha SJ, Lee JH, et al. Hair counts from scalp biopsy specimens in Asians. *J Am Acad Dermatol* 2002; 46:218-221.
- Sperling LC. Hair density in African Americans. *Arch Dermatol* 1999; 135:656-658.
- Whiting DA. Diagnostic and predictive value of horizontal sections of scalp biopsy specimens in male pattern androgenetic alopecia. *J Am Acad Dermatol* 1993; 28:755-763.
- Aslani FS, Dastgheib L, Banihashemi BM. Hair counts in scalp biopsy of males and females with androgenetic alopecia compared with normal subjects. *J Cutan Pathol* 2009; 36:734-739.
- Templeton SF, Santa Cruz DJ, Solomon AR. Alopecia: histologic diagnosis by transverse sections. *Semin Diagn Pathol* 1996; 13:2-18.
- Bouhanna P. Phototrichogram: a technique for the objective evaluation of the diagnosis and course of diffuse alopecia. In: Montagna W, Serri F, Bartolctti L, et al. eds. *Hair and Aesthetic Medicine*. Vol 1. Roma: Salus, 1983:277-280.
- Van Neste D, Dumortier M, De Coster W. Phototrichogram analysis: technical aspects and problems in relation to automated quantitative evaluation of hair growth by computer-assisted image analysis. In: Van Neste D, Lachapelle JM, Antoine JL, eds. *Trends in Human Hair Growth and Alopecia Research*. Dordrecht: Kluwer Academy Publishers 1989:155-165.
- Hoffmann R. TrichoScan: combining epiluminescence microscopy with digital image analysis for the measurement of hair growth in vivo. *Eur J Dermatol* 2001; 11:362-368.
- Loussouarn G. African hair growth parameters. *Br J Dermatol* 2001; 145:294-297.
- Jiménez F, Poblet E. Gross and microscopic anatomy of the follicular unit. In: Haber RS, Stough DB, eds. *Hair Transplantation*. Vol 1. Philadelphia: Elsevier, 2006:35-42.
- Jiménez F, Ruifernández JM. Distribution of hair in follicular units. *Dermatol Surg* 1999; 25:294-298.
- Ross EK, Vincenzi C, Tosti A. Videodermoscopy in the evaluation of hair and scalp disorders. *J Am Acad Dermatol* 2006; 55:799-806.
- Rudnicka L, Olszewska M, Rakowska A, et al. Trichoscopy: a new method for diagnosing hair loss. *J Drugs Dermatol* 2008; 7:651-654.
- Iorizzo M, Pazzaglia M, Starace M, et al. Videodermoscopy: a useful tool for diagnosing congenital triangular alopecia. *Pediatr Dermatol* 2008; 25:652-654.
- Ito S, Ozeki H, Wakamatsu K. Spectrophotometric and HPLC characterization of hair melanins. In: Hori K, Hearing VJ, Nakayama J, eds. *Melanogenesis and Malignant Melanoma: Biochemistry, Cell Biology, Molecular Biology, Pathophysiology, Diagnosis and Treatment*. Vol 1. Oxford: Oxford University Press, 2000:63-72.
- Messenger AG. The control of hair growth and pigmentation. In: Olsen EA, ed. *Disorders of Hair Growth—Diagnosis and Treatment*. Vol 1, 2nd ed. Barcelona: McGraw Hill, 2003:49-74.
- Rees JL. Genetics of hair and skin color (review). *Annu Rev Genet* 2003; 37:67-90.
- Nordlund JJ, Boissy RE, Hearing VJ, et al. *The Pigmentary System: Physiology and Pathophysiology*. New York: Oxford University Press, 1998.
- Wakamatsu K, Ito S. Advanced chemical methods in melanin determination. *Pigment Cell Res* 2002; 15:174-183.
- Wakamatsu K, Ito S, Rees JL. Usefulness of 4-amino-3-hydroxyphenylalanine as a specific marker of pheomelanin. *Pigment Cell Res* 2002; 15:225-232.
- Tobin DJ. Pigmentation of human hair. In: Tobin DJ, ed. *Hair in Toxicology—An Important Bio-Monitor*. Vol 1. Cambridge: RSC Publishing, 2005.
- Oyehaug L, Plahte E, Vage DI, et al. The regulatory basis of melanogenic switching. *J Theor Biol* 2002; 215:449-468.
- Inazu M, Mishima Y. Detection of eumelanogenic and pheomelanogenic melanosomes in the same normal human melanocyte. *J Invest Dermatol* 1993; 100:172S-175S.



42. Tobin DJ, Hordinsky M, Bernard BA. Hair pigmentation: a research update. *J Investig Dermatol Symp Proc* 2005; 10:275–279.
43. Wolfram LJ. Human hair: a unique physicochemical composite (review). *J Am Acad Dermatol* 2003; 48:S106–S114.
44. Baum JD, Hughes EA, Harris DA. Neonatal hair as a record of intra-uterine nutrition. *Biol Neonate* 1974; 25:208–218.
45. Khumalo NP, Dawber RP, Ferguson DJ. Apparent fragility of African hair is unrelated to the cystine-rich protein distribution: a cytochemical electron microscopic study. *Exp Dermatol* 2005; 14:311–314.
46. Dekio S, Jidoi J. Amino acid compositions of human hair fibrous protein components purified with two-dimensional electrophoresis. *J Dermatol* 1989; 16:453–457.
47. Dekio S, Jidoi J. Amounts of fibrous proteins and matrix substances in hairs of different races. *J Dermatol* 1990; 17:62–64.
48. O'Donoghue MN. Hair care products. In: EA O, ed. *Disorders of Hair Growth - Diagnosis and Treatment*. Vol 1, 2nd ed. Barcelona: McGraw Hill 2003:481–496.
49. Grimes PE. Skin and hair cosmetic issues in women of color. *Dermatol Clin* 2000; 18:659–665.
50. Olsen EA, Stenn K, Bergfeld W, et al. Update on cicatricial alopecia. *J Investig Dermatol Symp Proc* 2003; 8:18–19.
51. Ross EK, Tan E, Shapiro J. Update on primary cicatricial alopecias. *J Am Acad Dermatol* 2005; 53:1–37.
52. Otberg N, Wu WY, McElwee KJ, et al. Diagnosis and management of primary cicatricial alopecia: part I. *Skinmed* 2008; 7:19–26.
53. Adams RM, Maibach HI. A five-year study of cosmetic reactions. *J Am Acad Dermatol* 1985; 13:1062–1069.
54. Hamilton JB. Patterned loss of hair in man; types and incidence. *Ann N Y Acad Sci* 1951; 53:708–728.
55. Takashima I, Iju M, Sudo M. Alopecia androgenetica—its incidence in Japanese and associated conditions. In: Orfanos CE, Montagna W, Stuttgen G, eds. *Hair Research Status and Future Aspects*. Vol 1, 1st ed. New York: Springer Verlag, 1981:287–293.
56. Tang PH, Chia HP, Cheong LL, et al. A community study of male androgenetic alopecia in Bishan, Singapore. *Singapore Med J* 2000; 41:202–205.
57. Paik JH, Yoon JB, Sim WY, et al. The prevalence and types of androgenetic alopecia in Korean men and women. *Br J Dermatol* 2001; 145:95–99.
58. Pathomvanich D, Thienthaworn P, Manoshai S. A random study of asian male androgenetic alopecia in Bangkok, Thailand. *Dermatol Surg* 2002; 28:804–807.
59. Setty LR. Hair pattern of the scalp of white and negro males. *Am J Phys Anthropol* 1970; 33:49–55.
60. Salim A, David J, Holder J. Dissecting cellulitis of the scalp with associated spondylarthropathy: case report and review. *J Eur Acad Dermatol Venereol* 2003; 17:689–691.
61. Stites PC, Boyd AS. Dissecting cellulitis in a white male: a case report and review of the literature. *Cutis* 2001; 67:37–40.
62. Ramesh V. Dissecting cellulitis of the scalp in 2 girls. *Dermatologica* 1990; 180:48–50.
63. Scheinfeld NS. A case of dissecting cellulitis and a review of the literature. *Dermatol Online J* 2003; 9:8.
64. Wu WY, Otberg N, McElwee KJ, et al. Diagnosis and management of primary cicatricial alopecia: part II. *Skinmed* 2008; 7:78–83.
65. Kelly AP. Pseudofolliculitis barbae and acne keloidalis nuchae. *Dermatol Clin* 2003; 21:645–653.
66. Goette DK, Berger TG. Acne keloidalis nuchae. A trans-epithelial elimination disorder. *Int J Dermatol* 1987; 26:442–444.
67. Whiting DA. Cicatricial alopecia: clinico-pathological findings and treatment. *Clin Dermatol* 2001; 19:211–215.
68. Tan E, Martinka M, Ball N, et al. Primary cicatricial alopecias: clinicopathology of 112 cases. *J Am Acad Dermatol* 2004; 50:25–32.
69. Powell JJ, Dawber RP, Gatter K. Folliculitis decalvans including tufted folliculitis: clinical, histological and therapeutic findings. *Br J Dermatol* 1999; 140:328–333.
70. Powell J, Dawber RP. Successful treatment regime for folliculitis decalvans despite uncertainty of all aetiological factors. *Br J Dermatol* 2001; 144:428–429.
71. Sullivan JR, Kossard S. Acquired scalp alopecia. Part 2: a review. *Australas J Dermatol* 1999; 40:61–70.
72. Danforth CH, Trotter M. The distribution of body hair in white subjects. *Am J Phys Anthropol* 1922; 5:259.
73. Dronameraju KR. Hypertrichosis of the pinna of the human ear, Y-linked pedigrees. *J Genet* 1960; 57:230–243.
74. Na JI, Kwon OS, Kim BJ, et al. Ethnic characteristics of eyelashes: a comparative analysis in Asian and Caucasian females. *Br J Dermatol* 2006; 155:1170–1176.
75. Hwang K, Baik SH. Distribution of hairs and sweat glands on the bodies of Korean adults: a morphometric study. *Acta Anat* 1997; 158:112–120.
76. Otberg N, Richter H, Schaefer H, et al. Variations of hair follicle size and distribution in different body sites. *J Invest Dermatol* 2004; 122:14–19.
77. Mangelsdorf S, Otberg N, Maibach HI, et al. Ethnic variation in vellus hair follicle size and distribution. *Skin Pharmacol Physiol* 2006; 19:159–167.

## Ethnic differences in skin properties

Naissan O. Wesley, Lily Talakoub, and Howard I. Maibach

### INTRODUCTION

The United States has a rapidly expanding ethnic population. The U.S. census bureau projects that by the year 2056, greater than 50% of the U.S. population will be of non-Caucasian descent. Skin of color presents unique differences in skin pathophysiology, anatomic structure, and mechanisms of aging.

The terms ethnic skin, dark skin, and brown skin have been used to describe skin of color, traditionally of Fitzpatrick skin types III to VI (Table 44.1). These terms do not define any particular race, ethnicity or culture, and it certainly does not describe all skin types and pigmentations. Among all ethnicities, there is wide range of skin pigmentation. For the purposes of this chapter we will use the term "ethnic skin" to refer to patients with darker pigmentation other than that of Caucasians.

Distinctive differences in ethnic skin types not only contribute to different dermatologic disorders but also require unique approaches to skin care. Basic anatomic differences and their clinical implications are summarized in Table 44.2. While anatomic differences have been found, the basic science and clinical literature does not adequately elucidate physiologic differences of ethnic skin types, and the data is often subjective and contradictory. As more patients, however, present with concerns attributed to their unique skin physiology, clinicians are beginning to investigate the underlying skin properties that are fundamental to understanding disease processes.

Objective differences that have been found among ethnic skin types include melanosome distribution, stratum corneum thickness, transepidermal water loss (TEWL), pH, sebum content, elasticity, irritability, and response to photodamage (3–5). In this chapter we will highlight the literature with respect to these well-defined differences, as well as briefly highlight the data in which differences are not as well defined including skin topography, water content (WC), blood vessel reactivity, vellus hair follicle concentration, epidermal innervation, and corneocyte variability. As the population continues to become multicultural, the need for unique expertise in ethnic skin care will progressively be elucidated in the scientific and clinical literature.

### MELANOSOMES

The biosynthesis of melanin, a cutaneous pigment, occurs in a melanosome, a metabolic unit within the melanocyte; melanosomes are then transported via melanocyte dendrites to adjacent keratinocytes (2). Melanosome content, distribution, and reactivity is the most widely studied area of ethnic skin physiology. Differences in the number of melanocytes, number of melanosomes, and morphology of melanosomes has contributed to the development of objective definitions of skin color. These unique well studied features help prevent photoaging and skin cancer in chronically sun-exposed skin as well as

contribute to dyschromia prevalent to many ethnic skin types. Postinflammatory hyperpigmentation or hypopigmentation is a common consequence of many inflammatory skin conditions and treatment modalities in dark-skinned patients. Hyperpigmentation is caused by an increase in melanin production or an abnormal distribution of melanin pigment whereas in hypopigmentation there is a decrease in melanin production (6). The etiology of this phenomenon in dark-skinned patients is still unknown, however literature supports the hypothesis that it is secondary to cytokines and inflammatory mediators such as leukotriene (LT), prostaglandins (PG), and thromboxane (TXB) released during the inflammatory process (7). Tomita et al. have shown in *in vitro* studies that LTC<sub>4</sub>, LTD<sub>4</sub>, PGE<sub>2</sub>, and TXB<sub>2</sub> stimulate melanocyte enlargement and LTC<sub>4</sub> not only increases tyrosinase activity in melanocytes but also increases mitogenic activity of melanocytes (8).

In 1969, Szabo et al. (9) examined five Caucasoids, six American Indians, three Mongoloids (from Japan and China), and seven Negroids to observe melanosome groupings using electron micrographs. The melanosomes in keratinocytes of Caucasoids and Mongoloids were found to be grouped together with a surrounding membrane. In contrast, the Negroid keratinocytes showed numerous melanosomes, longer and wider than in other racial groups, and mostly individually dispersed. Additionally, they observed an increase in melanosomes of keratinocytes of all races after irradiation, with grouping of melanosomes maintained in Caucasoids and Mongoloids. The authors concluded that individually dispersed melanosomes give a more uniform and dense color than the grouping found in fair skin.

In 1973, Konrad et al. (10) studied melanosome distribution patterns in hyperpigmented white skin alone and found that when comparing hyperpigmented lesions with control areas, there were no uniform differences in the distribution patterns of melanosomes. In addition, the degree of clinical hyperpigmentation was not associated with specific distribution patterns. However, they did note an important relationship between melanosome size and distribution: the percentage of melanosomes dispersed singly increased with increasing melanosome size. The authors also reported findings with experimental pigment donation showing that large melanosomes are taken up individually by keratinocytes and dispersed singly within their cytoplasm while small melanosomes are incorporated and maintained as aggregates. This data suggested melanosome size differences as the basis for skin color differences between black skin and white skin.

More recently, Thong et al. (11) quantified variation in melanosome size and distribution pattern in Asian, Caucasian, and African American skin. The volar forearms of 15 Chinese (phototypes IV–V; ages 10–73 years), 3 Caucasians (phototype II; ages 22–49 years), and 3 African Americans (phototype VI,

**Table 44.1** Fitzpatrick Skin Phototype System

Skin phototype	Reaction to moderate sun exposure <sup>a</sup>	Skin color
Melanocompromized		
I	Burn and no tan	White
II	Burn and minimal tan	White
III	Burn then tan well	White to light olive
Melanocompetent		
IV	Tan, minimal to no burn	Light brown
V	Tan, no burn	Brown
VI	Tan, no burn	Dark brown

<sup>a</sup>Thirty minutes of unprotected sun exposure in peak season (spring or summer) depending on the latitude.

Source: From Ref. 1.

**Table 44.2** Therapeutic Implications of Key Biologic Differences Between Races

Biologic factor	Therapeutic implications
Epidermis	<ul style="list-style-type: none"> <li>• Lower rates of skin cancer in people of color</li> <li>• Less pronounced photoaging</li> <li>• Pigmentation disorders</li> </ul>
Dermis	<ul style="list-style-type: none"> <li>• Greater incidence of keloid formation in black persons compared with white persons</li> </ul>
Hair	<ul style="list-style-type: none"> <li>• Pseudofolliculitis in black persons who shave compared with white persons</li> <li>• Use of hair products (e.g., relaxers) that may lead to hair and scalp disorders in black persons</li> <li>• Alopecia</li> </ul>

Source: Adapted from Ref. 2.

ages 18–52) were examined by electron microscopy of 4-mm punch biopsies. The proportions of individual and clustered melanosomes were compared for each ethnic group and showed statistically significant differences ( $p < 0.05$ ). Melanosomes in Caucasian skin were distributed as 15.5% individual versus 84.5% clustered. Meanwhile, in African Americans, the melanosomes were distributed as 88.9% individual versus 11.1% clustered. The Asian melanosome distribution was intermediate between the latter two groups, as 62.6% individual versus 37.4% clustered. The investigators also determined the mean  $\pm$  standard deviation (SD) size of melanosomes distributed individually to be larger in comparison with those distributed in clusters for each ethnic group. The mean  $\pm$  SD of random melanosomes in each group differed as African American skin showed significantly larger melanosome size than Caucasian skin, and Asian skin showed melanosome size as intermediate between the two other two groups. Thus, there was a trend of progressive increase in melanosome size when moving from Caucasian to African American skin that corresponded with the progression from predominantly clustered to predominantly individual melanosome distribution. In addition, degradation patterns of melanosomes in the upper levels of epidermis varied by ethnic group. As keratinocytes became terminally differentiated and migrated to the stratum corneum, melanosomes were completely degraded and absent in the stratum corneum of light skin, while intact melanosomes could be seen in the stratum corneum of dark skin. Asian skin showed an intermediate pattern where few melanosomes remained in the corneocytes; interestingly, the remaining melanosomes were predominantly individual, indicating that

clustered melanosomes may be degraded more efficiently during this process.

Alaluf et al. (12) examined the morphology, size, and melanin content of melanosomes on the volar upper arms and dorsal forearms of 10 European, 8 Chinese, 10 Mexican, 10 Indian, and 10 African subjects living in South Africa. Four-millimeter punch biopsies were analyzed on the basis of electron micrographs of melanosomes and on alkali solubility of extracted melanin. The melanosome size of dorsal forearm (photoexposed) skin was observed as approximately 1.1 times larger than melanosome size of volar upper arm (photoprotected) skin ( $p < 0.001$ ) when data was pooled from all ethnic groups; each ethnic group separately showed a similar trend, but lacked statistical significance. In addition, a progressive and statistically significant increase in average melanosome size was observed when moving from European (light) to African (dark) skin types. The melanosome size was directly correlated with total melanin content in the epidermis of all subjects ( $p < 0.0001$ ). When comparing the epidermal melanin content among ethnic groups, the investigators found a downward trend in the amount of alkali soluble melanin (light-colored pheomelanin and DHICA-enriched eumelanin) in epidermis as the skin type became progressively darker; African skin contained the lowest amount ( $p < 0.02$ ). Indian skin presented an exception to this trend with higher concentrations of light melanin fractions than both Mexican and Chinese skin ( $p < 0.05$ ). However, both African and Indian skin showed about two times more of the alkali insoluble melanin (dark-colored DHI-enriched eumelanins) than the Mexican, Chinese, and European skin types ( $p < 0.001$ ). Overall, the melanin

composition showed a trend toward higher fractions of alkali soluble melanins while moving from darker (African) skin to lighter (European) skin. In addition, African and Indian skin revealed the highest total amount of melanin ( $p < 0.001$ ) and did not differ significantly from each other. There was no significant difference in total epidermal melanin between the remaining groups.

Despite the data showing differences in number and distribution of melanosomes, recent studies find no evidence of differences in numbers of melanocytes among ethnic groups (2). For example, Alaluf et al. (13) found no significant difference in melanocyte number between African ( $n = 10$ ), Indian ( $n = 10$ ), Mexican ( $n = 10$ ), or Chinese ( $n = 8$ ) skin types using immunohistochemical methods. They did consistently find 60% to 80% more melanocytes in European ( $n = 10$ ) skin than all other skin types ( $p < 0.01$ ), but the authors felt a larger sample size would be necessary to confirm this observation. Tadokoro et al. (14) also found approximately equal densities of melanocytes in unirradiated skin of Asian, black, and white subjects ranging from 12.2 to 12.8 melanocytes/mm.

It is generally accepted that differences in skin color are supported more by differences in melanosome distribution, size, and content rather than melanocyte number. The basic understanding of these differences is necessary to understand not only the range of pigmentation of the various ethnic groups but also the difference in particular skin diseases in these populations.

### TRANSEPIDERMAL WATER LOSS

One of the integral roles of the skin is to maintain a barrier between the body and the external environment (15). The stratum corneum is the permeability barrier of the skin. An objective measure of stratum corneum and barrier integrity is the calculation of TEWL. TEWL measures water loss from the skin in  $\text{g}/\text{m}^2/\text{hr}$ , excluding losses due to sweating (16). Normal daily TEWL in adults ranges between 3.9 and 7.6  $\text{g}/\text{m}^2/\text{hr}$ . The repair mechanism of the stratum corneum in response to detergents, solvents, and trauma is to minimize TEWL by increasing the machinery needed for lipid synthesis and secretion. To date, TEWL is the most studied objective measure in defining differences between the skin of different ethnicities.

The stratum corneum is made of keratinocytes embedded in a matrix of parallel lamellar membranes made of cholesterol, free fatty acids and glucosylceramides. The barrier repair mechanism relies on the synthesis and regulation of these three components, in equimolar concentrations as well as the natural moisturizing factor (NMF) made from the hydrolysis of the protein fillagrin. The cohesion of corneocytes form the cornified envelope, while the lipid matrix provides the stratum corneum's barrier function. A 1% increase in TEWL, triggers multiple enzymatic functions to repair the barrier. Furthermore, stratum corneum homeostasis is also highly regulated by factors such as pH and calcium levels.

Wilson et al. (17) demonstrated higher in vitro TEWL values in black compared with white skin using skin taken from 10 African American and 12 Caucasian cadavers matched for age and gender. A subsequent in vivo study by Berardesca and Maibach (18) supported the findings of the in vitro study by evaluating the difference in irritation between young black and white skin after the application of 0.5% and 2.0% sodium laurel sulfate, a water soluble irritant (surfactant), to untreated, preoccluded, and predelipidized skin. The data was quantified

on the basis of WC, TEWL, and laser Doppler velocimetry (LDV) of the stratum corneum. No statistical difference was found in irritation between the two groups on the basis of WC and LDV. However blacks had 2.7 times higher TEWL levels than whites ( $p < 0.04$ ), suggesting that blacks in the preoccluded state are more susceptible to irritation than whites. This theory opposes the traditional clinical view, based on observing erythema (19), that blacks are less reactive to irritants than whites. Additional studies such as those by Kompaore et al. (20), and Sugino et al. (21) also found significantly higher TEWL values in blacks and Asians compared with whites.

Berardesca and Maibach (22) used the same model to compare differences in irritation between Hispanic and white skin. Although there were no significant differences in TEWL, WC or LDV between the groups at baseline, the data showed higher values of TEWL, though not statistically significant, for Hispanics compared with whites after sodium laurel sulfate-induced irritation. The investigators noted that the reaction of Hispanic skin to sodium laurel sulfate resembled that of black skin when irritated with the same substance (18). Since skin pigmentation varies greatly within the Hispanic and black communities, the degree of skin pigmentation, according to Fitzpatrick's model (23), could represent an important variable.

This data, however, could not be reproduced in later studies by Berardesca et al. (24) who found no significant difference in vivo in TEWL between race or anatomic site in blacks, whites, and Hispanics, matched for age and gender. Skin sites that vary in sun exposure, dorsal and volar forearm, were used to highlight the protective effects of melanin from ultraviolet-induced damage. Ethnic differences in skin conductance (blacks > whites) and skin elasticity were found. However, even though the investigators expected a higher TEWL in blacks, on the basis of previous studies (17,18) and on the basis of a higher WC (skin conductance) in blacks found in their current study, no significant difference in TEWL was found between races or anatomic sites. They accounted for the higher WC in black skin with no ethnic differences in TEWL on the basis that black skin might have increased intercellular cohesion (5) and increased lipid content (25), which retains the water in the stratum corneum.

The effect of skin pigmentation on TEWL, as opposed to race, was evaluated by Reed et al. (26) in skin types II to VI. Subjects with skin type V/VI required more tape strippings ( $66.7 \pm 6.9$ ) compared with skin type II/III ( $29.6 \pm 2.4$ ) to achieve the same TEWL, that is, skin type V/VI had increased barrier strength (integrity). These findings correlate with those of Weigand et al. (5) that black skin has more cell layers and increased intercellular adhesion. Furthermore, it was also found that water barrier function (measured by TEWL) in skin type V/VI recovered more quickly. This study demonstrates differences in stratum corneum barrier function between different skin types independent of race.

Further studies by Berardesca et al. (27), Tagami et al. (28), Aramaki et al. (29), Astner et al. (30), and Pershing et al. (31), all highlight differences in TEWL and skin irritancy between Caucasian and non-Caucasian skin. While the data regarding TEWL are somewhat conflicting (17,20–22,26,27), there is increased evidence of reproducible differences among ethnic skin in TEWL, WC, and skin irritancy. This data however does not fully validate the hypothesis that water barrier function depends on degree of pigmentation, as there has been no studies on barrier integrity in cases of acquired hyperor hypopigmentation. Furthermore, TEWL may vary under different pathologic and physiologic

conditions such as disease, overall lifetime UV exposure, medication use, or fillagrin mutation.

## WATER CONTENT

WC is a measure of the hydration of the skin. WC can be measured by several methods including skin capacitance, conductance, impedance, and resistance. Using capacitance to measure WC is based on the high dielectric constant of water compared with other substances (32). Conductance is also based on the changes in the electrical properties of the stratum corneum when the skin is hydrated (33). Dry stratum corneum provides weak electrical conduction, while hydrated stratum corneum has a greater electrical field (32). Resistance is the reciprocal of conductance. In general, skin capacitance and conductance show similar behavior with regards to measuring WC of the skin, while resistance and impedance are opposite. Possible sources of error or variation in measurement include sweat production, filling of the sweat gland ducts, the number of hair follicles, the electrolyte content of the stratum corneum, and artifacts from topically applied agents (33).

Berardesca and Maibach compared WC by capacitance before and after topical administration of sodium laurel sulfate in blacks and whites, and in another study, in Hispanics and whites (18,22). There were no significant differences in WC between blacks and whites at baseline or after sodium laurel sulfate-induced stress (18). In comparing Hispanics and whites, there was an increase in WC in Hispanics at baseline, but the difference was not significant; however, after sodium laurel sulfate application, they found a significant increase in WC in Hispanics compared with whites when a negative visual score (i.e., no erythema) was given for irritation ( $p < 0.01$ ) (22). In reviewing the data, however, we found that the although the mean values for WC in Hispanics were greater than in whites, the SD were also large. When an irritant reaction was visually detectable, the WC was proportionally increased in both races, eradicating a difference between them.

Sugino et al. (21) measured WC with an impedance meter in blacks, whites, Hispanics, and Asians. They found that WC was highest in Asians compared with Caucasians, blacks, and Hispanics. The investigators correlated high WC with high ceramide and low TEWL values also measured in their study.

Similar studies by Warriar et al. (34) examined WC by capacitance at baseline in 30 black and 30 white women aged 18 to 45 years. Black women had a significantly higher WC on the cheeks ( $p < 0.05$ ), but there were no significant differences at baseline between blacks and whites on the forearms and the legs. They proposed that the difference found on the cheeks might be related to evidence of more elaborate superficial vasculature and more apocrine and mixed eccrine-apocrine glands in facial skin of blacks (35), as well as on differences in melanin content, the packaging of melanocytes, and their ability to prevent epidermal photodamage (36,37).

Manuskiatti et al. (38) found no differences in WC between black and white women, but did find that younger women had higher WC than older women. Similarly, Sivamani et al. (39) compared differences in friction coefficient, impedance, and amplitude/mean calculation of friction coefficient curves between Caucasian, African American, Hispanic, and Asian subjects. The authors concluded that there is little variation in volar forearm skin across gender, age, and ethnicity, providing an adequate site for testing of skin and cosmetic products. Finally, Grimes et al. (40) measured baseline moisture

content on the inner forearms of 18 African American and 19 white women aged 35 to 65 years on the basis of capacitance. The study found no significant variation in baseline moisture content between African American and white subjects.

The overall evidence points to similar WC in different ethnicities. However, these findings, by measuring skin capacitance, conductance, impedance and resistance, are difficult to interpret in terms of stratum corneum WC because other physical factors, such as skin microrelief, sweat production, topical agent application, and the presence of hair on the measuring site, all of which can modify the quality of skin electrode contact (32). These confounding factors can play a role in the degree of WC and thus should be taken into consideration in future studies.

## CORNEOCYTE VARIABILITY

Corneocytes differ in shape, thickness and spatial arrangement (41). In Caucasians, the surface area of corneocytes differs by body site (41,42) and age (41,43). It has also been demonstrated in Caucasians that corneocyte surface area is an important factor in the permeability of the skin to water loss and to percutaneous absorption of topically applied substances (41).

Corcuff et al. (44) compared corneocyte surface area and spontaneous desquamation on the arms of white, black, and Asian age-matched subjects. No difference in corneocyte surface area was found between the groups. However, spontaneous desquamation (corneocyte count) was increased in blacks by factor of 2.5 compared with white and Asian skin ( $p < 0.001$ ). The investigators felt that their findings were not consistent with earlier studies that showed increased intercellular adhesion (5) or increased TEWL (17,18) in black skin. This enhanced desquamation may partially account for "ashing" frequently seen clinically in black skin.

In contrast, Warriar et al. (34) found the lower corneocyte desquamation on the cheeks and foreheads of blacks compared with whites and attributed this to possible differences in moisturizing properties of sebum. Since it is believed that corneocyte surface area varies by anatomic site in Caucasians (41), perhaps corneocyte desquamation also varies by site. Corcuff et al. (44) studied the upper outer arm, whereas Warriar et al. (34) examined the cheeks, forearms, and lower legs. Confounding factors in these studies not only include anatomic site but also relative outdoor humidity, topical agents applied to the skin, and climate.

Similar studies by Manuskiatti et al. (38) revealed no differences in desquamation index between blacks and whites at all areas measured, except at the preauricular cheek ( $p = 0.02$ ). Overall, they concluded that age and anatomic site, but not race, demonstrate a significant influence on skin roughness and scaliness.

The studies by Corcuff et al. (44), Warriar et al. (34), and Manuskiatti et al. (38) provide contradictory conclusions. We believe future studies need to be done using similar sites and controlling for different climate, outdoor humidity, and skin care applied to the skin.

## BLOOD VESSEL REACTIVITY

The cutaneous microcirculation plays a large role in skin physiology, irritation, delivery of drugs, and wound healing (45). Two techniques used to measure this are LDV and photoplethysmography (PPG).

LDV is a noninvasive method that tracks the flow of red blood cells. It is based on measurement of the Doppler frequency shift in monochromatic laser light backscattered from moving red blood cells. It detects the frequency-shifted signal and derives an output proportional to the number of erythrocytes multiplied by their velocity in the cutaneous microcirculation (45,46). LDV has been used in many fields including those of understanding skin disease such as Raynaud's and scleroderma, the testing of irritancy of topical drugs, cosmetics, detergents, cleansing agents, and industrial products as well as understanding the effects of drugs such as vasodilators, sunscreens and topical corticosteroids (45).

PPG can be defined as the continuous recording of the light intensity scattered from a given source by the tissues and collected by a suitable photodetector (47). Specific to the skin, it allows the registration of changes in the dermal vasculature and is synchronized with heartbeat. Infrared light from a transducer is absorbed by hemoglobin, and the backscattered radiation is detected and recorded. The backscattered light depends on the amount of hemoglobin in the skin, and the result obtained will therefore reflect the cutaneous blood flow (45).

Guy et al. (48) evaluated blood vessel reactivity in age-matched black and white subjects using LDV and PPG. They found no significant difference between the ethnic groups. Similarly Berardesca and Maibach (18) performed a study to determine the difference in irritation between young black and Caucasian skin after the application of 0.5% and 2.0% sodium laurel sulfate to untreated, preoccluded, and predelipidized skin and then quantified the resulting level of irritation using LDV, TEWL and WC of the stratum corneum. There were no significant differences between black and white skin for LDV at baseline or after application of sodium laurel sulfate. The authors did note, however, that in blacks, application of the 0.5% sodium laurel sulfate to untreated skin revealed minimal changes in cutaneous blood flow (as measured by LDV) compared with baseline. They used this finding to explain the decreased irritant-induced perceptible erythema in blacks (49). Berardesca and Maibach (22) used the same model to compare differences in irritation between Hispanic and Caucasian skin. This study also revealed similar blood vessel responses between the two groups.

In a subsequent study, Berardesca and Maibach used LDV to measure ethnic differences induced by corticosteroid application (a vasoconstrictive stimulus) (50). They examined six black and eight Caucasian men, matched for age, and measured cutaneous hyperemia using LDV, before and after the application of 0.05% clobetasol ointment to the forearm. In their analysis, black subjects showed a 40% decreased area under the curve response ( $p < 0.04$ ), a 50% decreased peak response ( $p < 0.01$ ), and a decreased decay slope after peak blood flow ( $p < 0.04$ ) compared with the whites. Overall, their data were consistent with a decrease in blood vessel reactivity of blacks compared with whites.

Gean et al. (69) also found differences in blood vessel reactivity between different ethnic groups; the investigators observed that the area under the curve for LDV response versus time was greater in blacks than Caucasians after application of methyl nicotinate (a vasodilator) ( $p < 0.05$ ). This contrasts with prior studies, which found either no difference (18,48) or a decrease (50) in the area under the curve response in blacks. Note, however, that in this study a vasodilator (methyl nicotinate) was given, whereas in the prior study by Berardesca and Maibach (50) a vasoconstrictor was given. They

also found that the area under the curve response versus time was greater in Asians compared with Caucasians for higher dose levels of methyl nicotinate ( $p < 0.05$ ).

Finally, a similar study by Kompaore et al. (20) revealed ethnic differences in time to vasodilation whereas studies by Aramaki et al. (29) and Hicks et al. (40) found no difference in baseline ethnic skin blood vessel reactivity.

Differences in racial/ethnic blood vessel reactivity do exist. However, since each of the above studies administered different vasoactive substances that may act on different receptors on blood vessels, they could not be objectively compared (51). Furthermore, comments summarized by Hicks et al. (40) and others reveal that small changes in the position of the measuring probe and anatomic site can produce significant changes in measurements and may result in decreased reliability of results.

### ELASTIC RECOVERY/EXTENSIBILITY

The data on skin elastic recovery and extensibility vary by anatomic site and by race. Age is also a large confounding factor. Berardesca et al. (24) evaluated elastic recovery and skin extensibility, on the dorsal and volar forearm in blacks, whites and Hispanics by applying a torque parallel to the skin's surface and quantifying skin extensibility and the time required for the skin to return to its original state after release of the torque. There were no significant differences between the races with respect to extensibility. However, elastic recovery was 26% less in blacks compared with whites on the volar forearm ( $p < 0.001$ ). There was no significant difference in elastic recovery between whites and Hispanics. The authors suggest the difference is due to greater actinic damage in whites compared with the photoprotective melanocytes in blacks. This conclusion can also be drawn because within each race as there were significant differences between dorsal and volar forearms in Hispanics and whites (dorsal < volar) ( $p < 0.0002$  and  $p < 0.0001$ , respectively), but extensibility was the same on both sides of the forearm in blacks likely due to the photoprotected volar surface of the forearm. Finally, skin elasticity overall is defined as elastic recovery divided by extensibility. The investigators found no significant differences between the races with respect to this ratio.

Contradicting this study, Warriar et al. (34) examined elastic recovery in black and white women and found no significant difference between blacks and whites on the legs, but elastic recovery on the cheeks was 1.5 times greater in blacks than in whites ( $p < 0.05$ ). Warriar et al. (34) explained their findings of higher elastic recovery on the cheeks of blacks on the basis of the higher WC in the same anatomic area, thus presumably resulting in a higher elastic deformation. These conflicting studies are outlined in Table 44.3, however further studies with more standardized methods are warranted to be able to draw further conclusions.

### pH GRADIENT

The pH of the skin plays a crucial role in skin homeostasis and barrier recovery mechanisms. Ethnic differences in pH have been studied, but only until recently has pH been elucidated to play a role in melanosome reactivity. In a study by Elias et al., stratum corneum pH, permeability barrier homeostasis, and SC integrity in three geographically different populations with pigment type I/II versus IV/V skin were evaluated. Type IV/V subjects

**Table 44.3** Summary of Ethnic Differences in Skin Properties

Evidence supports	Insufficient evidence for <sup>a</sup>	Inconclusive
Racial differences in <ul style="list-style-type: none"> <li>• melanosome distribution,</li> <li>• transepidermal water loss,</li> <li>• pH black &lt; white skin,</li> <li>• variable racial blood vessel reactivity, and</li> <li>• photodamage.</li> </ul>	Racial differences in <ul style="list-style-type: none"> <li>• skin elastic recovery/extensibility,</li> <li>• lipid content,</li> <li>• vellus hair follicles, and</li> <li>• epidermal innervation.</li> </ul>	Racial differences in <ul style="list-style-type: none"> <li>• water content,</li> <li>• corneocyte desquamation, and</li> <li>• sebum content and secretion.</li> </ul>

<sup>a</sup>Labeled as “insufficient evidence for” racial differences rather than “inconclusive” because only two studies or less examined these variables.  
Source: Adapted from Ref. 52.

showed (i) lower surface pH (approximately 0.5 U), (ii) enhanced SC integrity (TEWL change with sequential tape strippings), and (iii) more rapid barrier recovery than type I/II subjects. The authors concluded that enhanced barrier function may be due to increased epidermal lipid content, increased lamellar body production, and reduced acidity, leading to enhanced lipid processing. In type I/II skin, there is decreased barrier integrity due to increased serine protease activity, resulting in accelerated desmoglein-1 (DSG-1)/corneodesmosome degradation. In contrast, DSG-1-positive corneodesmosomes persisted in type IV/V subjects, but because of enhanced cathepsin-D activity, SC thickness did not increase. Additionally, an increase of acidity of type I/II skin to that equal to type IV/V skin improved epidermal function. The most intriguing aspect of this study illustrated that dendrites from type IV/V melanocytes were more acidic and transfer more melanosomes than those from type I/II subjects. This could suggest that melanosome secretion could contribute to the more acidic pH of type IV/V skin (53).

In contrast, Berardesca et al. (27) also examined differences in pH in skin types I/II and skin type VI women at baseline and after tape stripping. They found no significant differences between the two races in pH at baseline. After tape stripping, however, they found a significantly lower pH in blacks compared with whites after three tape strippings, but no significant differences after 9, 12, and 15 strippings. Thus, there was a lower pH in black skin compared with white skin in the superficial layers of the stratum corneum, but not in the deeper layers. The investigators stated that the data were difficult to explain. It was hypothesized that since the TEWL was also found to be increased after three and six tape strippings, the increased TEWL might allow for an increase in the hydrogen ion concentration in a normally hydrophobic stratum corneum. Of note, although the difference between the races in pH was not significant at deeper layers of the stratum corneum, the pH in both races did decrease with more tape strippings, but TEWL did not follow the same trend. Thus, an increase in TEWL does not fully explain the findings in pH.

Warrier et al. (34) also included pH in their study of 30 black and 30 white women; however, they only examined pH at baseline, not after tape stripping. There was a decreased pH on the cheeks of blacks compared with whites, pH = 5.15 versus  $p = 5.52$ , respectively ( $p < 0.05$ ). There was also a decreased pH in blacks on the legs, but the difference was not significant. The authors attributed the decreased pH in blacks to a higher number of sweat glands secreting lactic acid and dicarboxylic amino acids in sweat secretions (35,54).

Similar results, though not statistically significant were also produced in the study by Grimes et al. (55). The skin pH, measured above the left eyebrow in African American women was found to be lower than in white women.

These studies, also highlighted in Table 44.3, highlight the well described phenomenon of lower pH in blacks compared with whites. However pH changes in the skin can be attributed to multiple causes, among them, genetics, environment, ultraviolet radiation, aging, atopic dermatitis, oral glucocorticoids, disease, diet, stress, and humid or dry environments. The highly regulated barrier function of the stratum corneum is intricately linked to its pH and alterations thereof could also explain racial differences in skin barrier function and irritancy.

## LIPID CONTENT

Ethnic differences in skin lipid content have been very contradictory. This is likely due to discrepancies in the literature highlighting lamellar membrane lipid content (ceramide, cholesterol, and free fatty acids) and the quantification of those lipids and that of sebaceous gland sebum production.

The greater the cohesion of the corneocytes, the greater the WC of the stratum corneum occurs, assuming the same TEWL. Sugino et al. (21) studied WC (by impedance), TEWL, and ceramide levels in black, white, Hispanic, and Asian subjects. Ceramide levels were 50% lower in blacks compared with whites and Hispanics but WC levels were highest in Asians. (They did not document the ceramide levels of Asians because according to their hypothesis, Asians should have the highest ceramide levels.) Thus, they correlated high WC and low TEWL in blacks with high ceramide levels. In contrast, Reinertson and Wheatley (25) showed higher total epidermis lipid and sterol content in blacks compared with whites when evaluating abdominal skin from cadavers and living white and black subjects.

Though the data is limited, epidermal lipid content plays a crucial role in barrier maintenance, homeostasis, and reaction to irritants. The discrepancy in the data may be due to the difficulty in quantifying the concentration of these lipids in the stratum corneum and the multiple confounders that play a role in the measurement of epidermal lipid content. Further studies are needed to elucidate these differences in ethnic skin and these differences may play a vital role in understanding disease mechanisms in the various skin types, including atopy and disorders of cornification.

## SEBUM CONTENT AND SECRETION

Sebum is an exogenous lipid secreted on the skin surface by sebaceous glands (56). Not only does sebum help maintain the barrier and protect from irritants and friction, but it also is broken down by the skin microflora resulting in free fatty acids that help acidify the stratum corneum. Sebum levels decline

with age, and are different on the basis of ethnicity. Using a sebumeter, Grimes et al. (55) measured the sebum content of African American and white women aged 35 to 65 years. The results showed lower levels of sebum on African American skin than on white skin, but these differences were not statistically significant.

Aramaki et al. (29) assessed sebum secretion as a part of their study investigating skin reaction to sodium lauryl sulfate at concentrations of 0.25% and 0.5%. Before and after application of SLS to the forearms of each subject, sebum levels were determined by a sebumeter. The baseline sebum levels were lower in Japanese women than in white women. However, after SLS application, sebum levels were higher in the Japanese women ( $p < 0.05$ ).

Rigal et al. (57) (abstract only) investigated the skin sebaceous function of 387 women of African American, Hispanic, Caucasian, or Chinese descents. Measurements were performed using a sebumeter and sebutape on the forehead and cheeks to compare sebum excretion rate and number of sebaceous glands according to ethnicity and age. The mean gland excretion was the same across ethnic groups. However, the number of sebaceous glands was lower in Chinese and Hispanic groups as compared with Caucasian and African American groups. In addition, the normal sebum decrease with age was different in each population; the decrease was linear in the Chinese group, but the other three groups exhibited a sudden decrease around age 50 years. Similar to the lipid content of the skin, further studies are needed to elucidate sebum concentration barrier function of different ethnic groups.

## VELLUS HAIR FOLLICLES

Vellous hair follicle distribution is been known to be greater blond/red haired individuals. However, a paucity of data exists for in ethnic skin types. Follicular morphology and distribution not only affect penetration of topical medications but also contributes to wound healing as stem cells arise from the base of hair follicles. Mangelsdorf et al. (58) investigated vellus hair follicle size and distribution in Asians and African Americans as compared with whites. Skin surface biopsies were taken from seven body sites of 10 Asians and 10 African Americans, ages 25 to 50 years. The body sites were matched to locations described by Otberg et al. (59) in their study on Caucasians. In comparing the results of the three ethnic groups, the distribution of follicle density at different body sites was the same; the highest average density was on the forehead and the lowest on the calf for all groups. However, follicular density on the forehead was significantly lower in Asians and African Americans ( $p < 0.001$ ). The Asians and African Americans also exhibited smaller values for volume ( $p < 0.01$ , both groups), potential penetration surface ( $p < 0.01$ , both groups), follicular orifice ( $p < 0.01$  and  $p < 0.05$ , respectively), and hair shaft diameter ( $p < 0.01$ , both groups) on the thigh and calf regions. In addition, the follicular reservoir, as described by follicular volume, was generally higher in Caucasians. The authors concluded that the significant ethnic differences in follicle structure and pattern of distribution. This study highlights the importance of measuring drug absorption in clinical trials using a range of ethnicities rather than just in Caucasians. There is clear evidence illustrating the difference of drug penetration and absorption depending on the physiology of the skin in various ethnicities.

## EPIDERMAL INNERVATION

While TEWL, WC, and blood vessel reactivity have been used as measures of irritancy, Reilly et al. (60) utilized confocal microscopy to evaluate ethnic differences in irritancy in terms of differences in skin innervation and nociceptor activity. They visualized epidermal innervation of the volar forearm pretreated with capsaicin in Caucasian-European, Japanese-American, and Chinese-American volunteers. However, there were no differences found in innervation, including the biochemical properties of the nerve fibers.

## PHOTODAMAGE

It has been well established that aging has many etiologic contributions. Genetics, gravity, behavior, and environment all play an important role in the aging process; however, many of the cutaneous signs of aging are due to UV exposure. Photodamage is defined as prematurely aged skin resulting from the effects of UV radiation. It is characterized by coarse and fine wrinkling, mottled pigmentation, sallowness, textural roughness, and telangiectasias. Histologic features include epidermal and dermal thinning, loss of polarity of epidermal cells, and keratinocyte atypia. Dermal features include elastosis, degeneration of collagen and anchoring fibrils (61). Dark skin has added protection from UV radiation owing to the increased melanin content.

In determining a relationship between melanosome groupings and sun exposure, studies have observed that dark-skinned whites, when exposed to sunlight, have nonaggregated melanosomes, in contrast to light-skinned, unexposed whites who have aggregated melanosomes. Similarly, there are predominantly nonaggregated melanosomes in sunlight-exposed Asian skin, and primarily aggregated melanosomes in unexposed Asian skin (2,62).

Alaluf et al. (12) noted an increase in melanosome size in photoexposed skin versus photoprotected skin in all ethnic groups; the melanosome size was directly correlated with epidermal melanin content, suggesting increased melanogenesis in photoexposed areas. Van Nieuwport et al. (63) demonstrated that with increased melanogenesis, light-skin melanosomes showed elongation and reduction in width with no significant change in surface area, while dark skin melanosomes enlarged in both length and width with an increase in volume. On the basis of this data, although all skin types show an increase in epidermal melanin with sun exposure, both distribution and morphology may influence unequal filtering between light and dark skin types.

In another study, Rijken et al. (64) investigated response to solar-simulating radiation (SSR) among white and black skin. Six healthy Dutch white subjects, with skin phototype I to III and mean age of 24.5 years, were exposed to 12,000 to 18,000 mJ/cm<sup>2</sup> of SSR. Six healthy West-African or Afro (South)-American black subjects, skin phototype VI, and mean age if 25.3 years, were exposed to 18,000 mJ/cm<sup>2</sup> of SSR. Six other white subjects were also added to study the effects of erythema effective doses of SSR. Skin pigment, DNA photodamage, infiltrating neutrophils, photoaging associated proteolytic enzymes, keratinocyte activation, and the source of interleukin 10 (IL-10) in skin biopsies taken before and after radiation. The significance of IL-10 lies in the fact that IL-10 producing cells may be involved in skin carcinogenesis. In each white volunteer, SSR caused DNA damage in epidermal and dermal cells, an influx of neutrophils, active proteolytic



enzymes, and keratinocyte activation. Also, three white volunteers showed IL-10 producing neutrophils in the epidermis. In black skinned individuals, aside from DNA damage in the suprabasal epidermis, there were no other changes found; basal keratinocytes and dermal cells were not damaged. The authors concluded that these results were best explained by difference in skin pigmentation and that melanin functions as a barrier to protect basal keratinocytes and the dermis from photodamage.

Other studies have suggested that filter properties of melanin, alone, do not provide sufficient protection against DNA damage in underlying cells. Tadokoro et al. (65) investigated the relationship between melanin and DNA damage after UV exposure in 37 subjects of five ethnic origins (black, white, Asian, others not specified), and Fitzpatrick phototypes I through VI. They found measurable damage to DNA in all groups, and DNA damage was maximal immediately after irradiation, gradually returning to baseline over time. The immediate DNA damage levels were higher in whites and Asians in comparison with blacks and Hispanics. In addition, the whites and Asians showed lower constitutive levels of melanin content. However, the kinetics of DNA damage differed among subjects. Upon monitoring the percentage of removal of damage toward baseline seven days after UV exposure, no correlation was found between melanin content or ethnic group and the efficiency of DNA damage removal. There were variable rates of DNA repair within individual groups indicating that DNA repair rates were not associated with skin type. The authors noted that other properties of melanin, such as antioxidant properties and radical scavenging properties, may play roles in minimizing UV damage. Ethnic differences in expression of receptors involved in melanosome uptake and melanocyte-specific proteins, both before and after UV exposure, are also being investigated.

## CONCLUSIONS

The U.S. census bureau estimates that the ethnic population will increase over the next several decades and be nearly equivalent to that of whites (66). It has been predicted that people with skin of color will constitute a majority of the United States and international populations in the 21st century (67). Though there are many identifiable differences among ethnic skin types, few studies have been performed with adequate sample size and controlling for confounding factors to be able to delineate adequate conclusions. Furthermore, though there have been attempts to delineate the differences between black and white skin, few if any studies delineate these objective data in nonblack skin incorporating Asian, Hispanic, Mediterranean, Indian, Pacific Islander, etc., skin types. Finally, there are vast variations in skin physiology, pigmentation, and reactivity within *one* ethnic group such as those identified as "Asian," which encompass a range of skin types including Chinese, Japanese, Vietnamese, Filipino, and Thai all of whom have great variations in their skin physiology. Though the FDA currently recommends inclusion of more ethnic groups in dermatologic trials, citing evidence that physiologic differences in skin structure between races can result in varying efficacies of dermatologic and topical treatments (68), further research in both the genetic basis of race and ethnicity and skin physiology are warranted to account for all the of differences seen in the ethnically varied skin types.

## REFERENCES

1. Fitzpatrick TB. Skin Phototypes 2002, 20th World Congress of Dermatology, Paris, July 1-5, 2002.
2. Taylor SC. Skin of color: biology, structure, function, and implications for dermatologic disease. *J Am Acad Dermatol* 2002; 46(2 suppl):S41-S62.
3. Thomson ML. Relative efficiency of pigment and horny layer thickness in protecting the skin of Europeans and Africans against solar ultraviolet radiation. *J Physiol (Lond)* 1955; 127:236-246
4. Freeman RG, Cockerell EG, Armstrong J, et al. Sunlight as a factor influencing the thickness of the epidermis. *J Invest Dermatol* 1962; 39:295-298.
5. Weigand DA, Haygood C, Gaylor JR. Cell layers and density of Negro and Caucasian stratum corneum. *J Invest Dermatol* 1974; 62:563-568.
6. Ruiz-Maldonado R, Orozco-Covarrubias M. Postinflammatory hypopigmentation and hyperpigmentation. *Semin Cutan Med Surg* 1997; 16:36-43.
7. Morelli JG, Kincannon J, Yohn JJ, et al. Leukotriene C and TGF-alpha are stimulators of human melanocyte migration in vitro. *J Invest Dermatol* 1992; 98:290-295.
8. Tomita Y, Maeda K, Tagami H. Melanocyte-stimulating properties of arachidonic acid metabolites: possible role in postinflammatory pigmentation. *Pigment Cell Res* 1992; 5:357-361.
9. Szabo G, Gerald AB, Pathak MA, et al. Racial differences in the fate of melanosomes in human epidermis. *Nature* 1969; 222:1081-1082.
10. Konrad K, Wolff K. Hyperpigmentation, melanosome size, and distribution patterns of melanosomes. *Arch Dermatol* 1973; 107:853-860.
11. Thong HY, Jee SH, Sun CC, et al. The patterns of melanosome distribution in keratinocytes of human skin as one determining factor of skin colour. *Br J Dermatol* 2003; 149:498-505.
12. Alaluf S, Atkins D, Barrett K, et al. Ethnic variation in melanin content and composition in photoexposed and photoprotected human skin. *Pigment Cell Res* 2002; 15:112-118.
13. Alalluf S, Barrett K, Blount M, et al. Ethnic variation in tyrosinase and TYRP1 expression in photoexposed and photoprotected human skin. *Pigment Cell Res* 2003; 16:35-42.
14. Tadokoro T, Yamaguchi Y, Batzer J, et al. Mechanisms of skin tanning in different racial/ethnic groups in response to ultraviolet radiation. *J Invest Dermatol* 2005; 124:1326-1332.
15. Pillsbury DM, Shelley WB, Kligman AM, eds. *Dermatology*. Philadelphia: WB Saunders Co., 1956.
16. Rothman S (ed.). *Insensible water loss*. In: *Physiology and Biochemistry of the Skin*. Chicago: The University Chicago Press, 1954:233.
17. Wilson D, Berardesca E, Maibach HI. In vitro transepidermal water loss: differences between Black and white human skin. *Br J Dermatol* 1988; 199:647-652.
18. Berardesca E, Maibach HI. Racial differences in sodium lauryl sulphate induced cutaneous irritation: black and white. *Contact Dermatitis* 1988; 18:65-70.
19. Basketter DA, Griffiths HA, Wang XM, et al. Individual, ethnic and seasonal variability in irritant susceptibility of skin: the implications for a predictive human patch test. *Contact Dermatitis* 1996; 35:208-213.
20. Kompaore F, Marly JP, Dupont C. In vivo evaluation of the stratum corneum barrier function in Blacks, Caucasians, and Asians with two noninvasive methods. *Skin Pharmacol* 1993; 6(3):200-207.
21. Sugino K, Imokawa G, Maibach HI. Ethnic difference of stratum corneum lipid in relation to stratum corneum function (abstr). *J Invest Dermatol* 1993; 100(4):587.
22. Berardesca E, Maibach HI. Sodium-lauryl-sulphate-induced cutaneous irritation: comparison of White and Hispanic subjects. *Contact Dermatitis* 1988; 18:136-140.
23. Fitzpatrick TB. The validity and practicality of sun reactive skin type I through VI. *Arch Dermatol* 1988; 124:869-871.
24. Berardesca E, Rigal J, Leveque JL, et al. In vivo biophysical characterization of skin physiological differences in races. *Dermatology* 1991; 182:89-93.

25. Reinerston RP, Wheatley VR. Studies on the chemical composition of human epidermal lipids. *J Invest Dermatol* 1959; 32:49–59.
26. Reed JT, Ghadially R, Elias PM. Skin type, but neither race nor gender, influence epidermal permeability function. *Arch Dermatol* 1995; 131(10):1134–1138.
27. Berardesca E, Pirot F, Singh M, et al. Differences in stratum corneum pH gradient when comparing white Caucasian and Black African-American skin. *Br J Dermatol* 1998; 139:855–857.
28. Tagami H. Racial differences on skin barrier function. *Cutis* 2002; 70(6 suppl):6–7; discussion 21–23.
29. Aramaki J, Kawana S, Effendy I, et al. Differences of skin irritation between Japanese and European women. *Br J Dermatol* 2002; 146:1052–1056.
30. Astner S, Burnett N, Rius-Diaz F, et al. Irritant contact dermatitis induced by a common household irritant: a noninvasive evaluation of ethnic variability in skin response. *J Am Acad Dermatol* 2006; 54(3):458–465.
31. Pershing LK, Reilly CA, Corlett JL, et al. Assessment of pepper spray product potency in Asian and Caucasian forearm skin using transepidermal water loss, skin temperature and reflectance colorimetry. *J Appl Toxicol* 2006; 26:88–97.
32. Distanto F, Berardesca E. Hydration. In: Berardesca E, Eisner P, Wilhelm KP, et al., eds. *Bioengineering of the Skin: Methods and Instrumentation*. Boca Raton: CRC Press Inc, 1995:5–12.
33. Triebkorn A, Gloor M. Noninvasive methods for the determination of skin hydration. In: Frosch PJ, Kligman AM, eds. *Noninvasive Methods for the Quantification of Skin Functions*. Berlin; New York: Springer-Verlag, 1993:42–55.
34. Warrier AG, Kligman AM, Harper RA, et al. A comparison of Black and white skin using noninvasive methods. *J Soc Cosmet Chem* 1996; 47:229–240.
35. Montagna W, Carlisle K. The architecture of black and white skin. *J Am Acad Dermatol* 1991; 24:929–937.
36. Montagna W, Protta G, Kenney JA. Black Skin: Structure and Function. San Diego: Academic Press, 1993:1–12.
37. Kaidbey KH, Poh AP, Sayre M, et al. Photoprotection by melanin: a comparison of Black and Caucasian skin. *J Am Acad Dermatol* 1979; 1:249–260.
38. Manuskiatti W, Schwindt DA, Maibach HI. Influence of age, anatomic site and race on skin roughness and scaliness. *Dermatology* 1998; 196:401–407.
39. Sivamani RK, Wu GC, Gitis NV, et al. Tribological testing of skin products: gender, age, and ethnicity on the volar forearm. *Skin Res Technol* 2003; 9(4):299–305.
40. Hicks S, Swindells J, Middelkamp M, et al. Confocal histopathology of irritant contact dermatitis in vivo and the impact of skin color (black vs white). *J Am Acad Dermatol* 2003; 48(5):727–734.
41. Rougier A, Lotte C, Corcuff P, et al. Relationship between skin permeability and corneocyte size according to anatomic site, age, and sex in man. *J Soc Cosmet Chem* 1988; 39:15–26.
42. Plewig G, Marples BM. Regional differences of cell sizes in the human stratum corneum. *J Invest Dermatol* 1970; 54:13–18.
43. Leveque JL, Corcuff P, De Rigal J, et al. In vivo studies of the evolution of physical properties of the human skin with age. *Int J Dermatol* 1984; 23:322–329.
44. Corcuff P, Lotte C, Rougier A, et al. Racial differences in Corneocytes: a comparison between black, white, and oriental skin. *Acta Derm Venereol (Stockh)* 1991; 71:146–148.
45. Wahlberg JE, Lindberg M. Assessment of skin blood flow: an overview. In: Berardesca E, Eisner P, Maibach HI, eds. *Bioengineering of the Skin: Cutaneous Blood Flow and Erythema*. Boca Raton: CRC Press, Inc., 1995:23–27.
46. Oberger PA. Laser-doppler flowmetry. *Crit Rev Biomed Eng* 1990; 18:125.
47. Bernardi L, Leuzzi S. Laser doppler flowmetry and photoplethysmography: basic principles and hardware. In: Berardesca E, Eisner P, Maibach HI, eds. *Bioengineering of the Skin: Cutaneous Blood Flow and Erythema*. Boca Raton: CRC Press, Inc., 1995:31–55.
48. Guy RH, Tur E, Bjerke S, et al. Are there age and racial differences to methyl nicotinate-induced vasodilatation in human skin? *J Am Acad Dermatol* 1985; 12:1001–1006.
49. Weigand DA, Gaylor JR. Irritant reaction in Negro and Caucasian skin. *South Med J* 1974; 67:548–551.
50. Berardesca E, Maibach HI. Cutaneous reactive hyperemia: racial differences induced by corticoid application. *Br J Dermatol* 1989; 129:787–794.
51. Katzung BG. Introduction to autonomic pharmacology. In: Katzung BG, ed. *Basic and Clinical Pharmacology*. Los Altos: McGraw-Hill Co., Inc., 2001:75–91.
52. Wesley NO, Maibach HI. Racial (ethnic) differences in skin properties: the objective data. *Am J Clin Dermatol* 2003; 4(12): 843–860.
53. Gunathilake R, Schurer NY, Shoo B, et al. pH-regulated mechanisms account for pigment-type differences in epidermal barrier function. *J Invest Dermatol*. 2009; 129(7):1719–1729.
54. Dikstein S, Zlotogorski A. Skin surface hydrogen ion concentration (pH). In: Leveque JL, ed. *Cutaneous Investigation in Health and Disease*. New York: Marcel Dekker, 1989:59–78.
55. Grimes P, Edison BL, Green BA, et al. Wildnauer RH. Evaluation of inherent differences between African American and white skin surface properties using subjective and objective measures. *Cutis* 2004; 73(6):392–396.
56. Rawlings AV. Ethnic skin types: Are there differences in skin structure and function? *Int J Cosmet Sci* 2006; 28:79–93.
57. de Rigal J, Diridollou S, Querleux B, et al. The skin sebaceous function: ethnic skin specificity (abstr). *L’Oreal Ethnic Hair and Skin*, Chicago 2005.
58. Mangelsdorf S, Otberg N, Maibach HI, et al. Ethnic variation in vellus hair follicle size and distribution. *Skin Pharmacol Physiol* 2006; 19:159–167.
59. Otberg N, Richter H, Schaefer H. Variations of hair follicle size and distribution in different body sites. *J Invest Dermatol* 2004; 122:14–19.
60. Reilly DM, Ferdinando D, Johnston C, et al. The epidermal nerve fibre network: characterization of nerve fibres in human skin by confocal microscopy and assessment of racial variations. *Br J Dermatol* 1997; 137:163–170.
61. Kligman LH, Kligman AM. The nature of photoaging: its prevention and repair. *Photodermatol* 1986; 3(4):215–227.
62. Richards G, Oresajo C, Halder R. Structure and function of ethnic skin and hair. *Dermatol Clin* 2003; 21(4):595–600.
63. Van Nieuwpoort F, Smit N, Kolb R, et al. Tyrosine-induced melanogenesis shows differences in morphologic and melanogenic preferences of melanosomes from light and dark skin types. *J Invest Dermatol* 2004; 122(5):1251.
64. Rijken F, Bruijnzeel L, van Weelden H, et al. Responses of black and white skin to solar-simulating radiation: differences in DNA photodamage, infiltrating neutrophils, proteolytic enzymes induced, keratinocyte activation, and IL-10 expression. *J Invest Dermatol* 2004; 122(5):1251–1255(5).
65. Tadokoro T, Kobayashi N, Zmudzka BZ, et al. UV-induced DNA damage and melanin content in human skin differing in racial/ethnic origin. *FASEB J* 2003; 17(9):1177–1179; [Epub April 8, 2003].
66. US Census Bureau. Profile of general demographic characteristics, 2003.
67. Populations Projections Program. Population Division, U.S. Census Bureau. Projections of the resident population by race, Hispanic origin, and nationality: Middle series 2050–2070, Washington.
68. Chan J, Ehrlich A, Lawrence R, et al. Assessing the role of race in quantitative measures of skin pigmentation and clinical assessments of photosensitivity. *J Am Acad Dermatol* 2005; 52(4): 609–615.
69. Gean CJ, Tur E, Maibach HI, et al. Cutaneous responses to topical methyl nicotinate in Black, Oriental, and Caucasian subjects. *Arch Dermatol Res* 1989; 281:95–98.

## FURTHER READING

- Baker H. The skin as a barrier. In: Rook A, ed. *Textbook of Dermatology*. Oxford: Blackwell Scientific, 1986:355.
- Berardesca E, Maibach H. Ethnic skin: overview of structure and function. *J Am Acad Dermatol* 2003; 48(6 suppl):S139–S142.
- Carter E. Race vs ethnicity in dermatology. *Arch Dermatol* 2003; 139: 539–540.
- Coon CS. *The Origin of Races*. New York: Alfred A Knopf, 1962.
- Craig SS, DeBlois G, Schwartz LB. Mast cells in human keloid, small intestine, and lung by immunoperoxidase technique using a murine monoclonal antibody against tryptase. *Am J Pathol* 1986; 124:427–435.
- Diridollou S, de Rigal J, Querleux B, et al. Skin topography according to ethnic origin and age (abstr). *L'Oreal Ethnic Hair and Skin*, Chicago 2005.
- Distante F, Berardesca E. Transepidermal water loss. In: Berardesca E, Eisner P, Wilhelm KP, et al., eds. *Bioengineering of the Skin: Methods and Instrumentation*. Boca Raton: CRC Press, Inc., 1995:1–4.
- Dreher F, Arens A, Hostynek JJ, et al. Colorimetric method for quantifying human stratum corneum removed by adhesive tape-stripping. *Acta Derm Venereol (Stockh)* 1988; 78(3):186–189.
- Fitzpatrick TB, Szabo G, Wick MM. Biochemistry and physiology of melanin pigmentation. In: Lowell AG, ed. *Biochemistry and Physiology of the Skin*. New York: Oxford University Press, 1983:687–712.
- Guehenneux SI, Le Fur I, Laurence A, et al. Age-related changes of skin microtopography in Caucasian and Japanese women (abstr). *J Invest Dermatol* 2003; 121(1):0350.
- Harding CR, Moore AE, Rogers JS, et al. Dandruff: a condition characterized by decreased levels of intercellular lipids in scalp stratum corneum and impaired barrier function. *Arch Dermatol Res* 2002; 294:221–230.
- Johnson LC, Corah NL. Racial differences in skin resistance. *Science* 1962; 139:766–767.
- Kischer CW, Bunce H, Sheltar MR. Mast cell analysis in hypertrophic scars, hypertrophic scars treated with pressure and mature scars. *J Invest Dermatol* 1978; 70:355–357.
- Kligman AM, Shelly WB. An investigation of the biology of the human sebaceous gland. *J Invest Dermatol* 1973; 30:99–125.
- Larsen TH, Jemec GBE. Skin mechanics and hydration. In: Eisner P, Berardesca E, Wilhelm KP, et al., eds. *Bioengineering of the Skin: Skin Biomechanics*. Boca Raton: CRC Press LLC, 2002:199–200.
- Mackintosh J. The antimicrobial properties of melanocytes, melanosomes and melanin and the evolution of black skin. *J Theor Biol* 2001; 211(2):101–113.
- Marshall EK, Lynch V, Smith HV. Variation in susceptibility of the skin to dichloroethylsulphide. *J Pharmacol Exp Ther* 1919; 12:291.
- Modjtahedi SP, Maibach HI. Ethnicity as a possible endogenous factor in irritant contact dermatitis: comparing irritant response among Caucasians, Blacks, and Asians. *Contact Dermatitis* 2002; 47(5):272–278.
- Oppenheimer GM. Paradigm lost: race, ethnicity, and the search for a new population taxonomy. *Am J Public Health* 2001; 91(7): 1049–1055.
- Rebora A, Guarrera M. Racial differences in experimental skin infection with *Candida albicans*. *Acta Derm Venereol (Stockh)* 1988; 68: 165–168.
- Robinson MK. Population differences in skin structure and physiology and the susceptibility to irritant and allergic contact dermatitis: implications for skin safety testing and risk assessment. *Contact Dermatitis* 1999; 41:65–79.
- Robinson S, Dill D, Wilson J, et al. Adaptations of white men and Negroes to prolonged work in humid heat. *Am J Trop Med* 1941; 21:261.
- Sueki H, Whitaker-Menezes D, Kligman AM. Structural diversity of mast cell granules in Black and white skin. *Br J Dermatol* 2001; 144:85–93.
- Williams H. In reply to race vs ethnicity in dermatology. *Arch Dermatol* 2003; 139:289.
- Yosipovitch G, Theng CTS. Asian skin: its architecture, function, and differences from Caucasian skin. *Cosmet Toiletries* 2002; 117(9):57–62.

# The menopause, skin, and cosmetology

Michel Faure and Evelyne Drapier-Faure

## INTRODUCTION

The hormonal disorders of menopause affect the whole organism, including skin and skin appendages. Women can avoid or limit some side-effects of the menopause with hormonal replacement therapy (HRT) and an appropriate cosmetology may complement the favorable effects of HRT on the skin (1,2).

Skin changes at the menopause, in the perimenopause and in postmenopausal women include changes that can be related to the complex process of aging, and others, among them signs of cutaneous hyperandrogenism. These changes not only affect skin, but also mucous membranes, hair and other appendages. As far as skin and skin aging are concerned, HRT may be used with some success. However, HRT only very partially prevents or corrects what happens in terms of skin, mucous membranes and phaneres with the menopause, that is, the so-called hormonal aging of the skin (1–4).

## MENOPAUSE AND HRT

*Menopause* is a natural biologic process, not an estrogen deficiency disease. Menopause represents the permanent cessation of menses resulting from loss of ovarian follicular function (5). Menopause can occur spontaneously or be induced through a medical intervention, ie surgery, chemotherapy, radiation therapy. Aging of the female reproductive system begins at birth and proceeds as a continuum. It consists of a steady loss of oocytes from atresia or ovulation, which does not occur at a constant rate, as evidenced by the relatively wide range (42–58 years) for spontaneous menopause. Menopause is defined as the anchor point after 12 months of amenorrhea following the final menstrual period, which reflects a near complete but natural diminution of ovarian hormone secretion. In the western world, menopause occurs at an average age of 51.4 years. Although there has been an increase in life expectancy over the last century, the age of menopause has not changed, unaffected by improving nutrition and reduction of disease.

The term *premenopause* only refers to the whole of the (reproductive?) period prior to the menopause (since birth?) and therefore should be abandoned. *Perimenopause* (or menopause transition) begins with variation in menstrual cycle length and ends with the final menstrual period. For most women, the transition lasts approximately four years. *Postmenopause* is the span of life dating from the final menstrual period, and is defined as stage 1 (early: the five years following final menstrual period) and stage 2 (late, with a duration variable since ending with the woman's death). *Climateric* syndrome defines the symptomatology associated with the reproductive transition of perimenopause/menopause. This (and some changes in postmenopausal women such as osteoporosis) may be prevented with HRT (5).

Estrogen-based therapies for postmenopausal women may be divided into two categories: estrogen replacement therapy (ERT) and HRT, a combination of estrogen (for instance, estradiol, E2) and of progestin. Progestins reduce the risk of endometrial adenocarcinoma, which is significantly increased in women with a uterus who use unopposed estrogen. However, in some women, these progestins may favor the development of cutaneous signs of hyperandrogenism, such as seborrhea, acne, alopecia and facial hirsutism (1,2,5).

Porphyrias and lupus erythematosus (LE) are the only dermatologic conditions in which HRT should not be used (1,2,6,7). Although a few studies suggested that estrogen replacement does not increase the risk for lupus flares in postmenopausal women with LE (8–10), HRT and ERT may be responsible for clinical and biologic accentuations in women with lupus, and for a first manifestation of the disease in women with no past history. Melasma was evidenced in women under HRT (11).

The initiation of hormone therapy may be proposed around the menopause to treat menopause-related symptoms or to reduce the risk of osteoporosis or fractures in select postmenopausal women, or both. The benefit-risk ratio for HRT is favorable close to menopause but decreases with aging and with time since menopause in previously untreated women (12).

## SKIN AGING AND THE MENOPAUSE

Skin aging is a progressive and complex process, which corresponds to at least two major components. Intrinsic or chronobiologic aging, on one hand, affects all tissues, while photoaging, that is, helioderma, only affects skin in sun-exposed areas. Helioderma is not influenced by the hormonal status.

## THE SO-CALLED HORMONAL SKIN AGING

Around menopause, during premenopause and early postmenopause, the skin usually becomes thinner and rougher (Figs. 45.1 and 45.2). The so-called "dry skin" is only a rough skin, which is due to chemophysical alterations of the stratum corneum at the skin surface level, not to changes in dermal or epidermal hydration. Menopausal skin in non-sun-exposed areas is characterized by a diminution in skin thickness, that affects both the epidermis and the dermis, (Fig. 45.3) and by a decrease in some constituents of the dermal extracellular matrix such as collagens and glycoaminoglycans (13–15). Some 30% of skin collagen is lost during the first five years after menopause, that is, early postmenopause. This decrease in dermal collagen also parallels bone loss in postmenopausal women (16,17).



**Figure 45.1** Menopausal skin thinning.



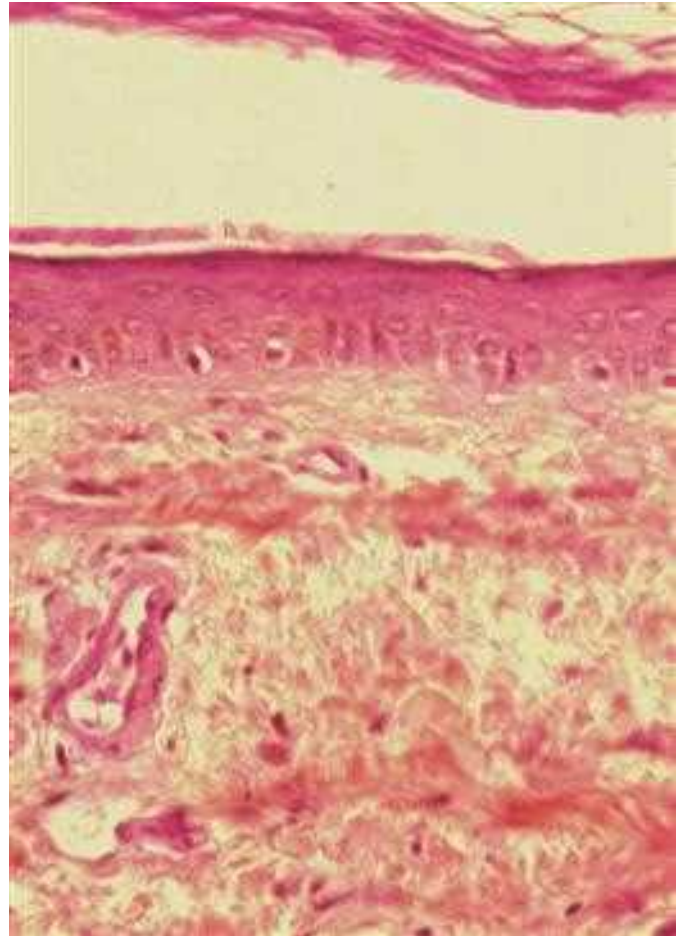
**Figure 45.2** Menopausal “dry skin.”

What is also generally observed is an increase in percutaneous water loss correlated to alterations in the hydration and the lipid constitution of the stratum corneum, which becomes more compact (1,3,4). Taken together, this leads to alterations in skin extensibility (increased), and elasticity (decreased) (18).

The correction of some skin changes in postmenopausal women with HRT supports the existence of what has been called *hormonal skin aging*.

### HORMONE REPLACEMENT THERAPY AND SKIN AGING

The observation of cutaneous change correction in postmenopausal women under ERT suggests that some skin alterations noted with aging are due to the decrease in estrogens. Studies in postmenopausal women indicated that the skinfold thickness is maintained with long-term hormone therapy (19). In



**Figure 45.3** Epidermal thinning and compact stratum corneum.

some initial studies it was suggested that oral estrogen therapy can prevent epidermal thinning for at least three years after castration (20).

More recent studies (ultrasonography and skin biopsies) indicated that skin atrophy and dermal atrophy in sun-unexposed areas are corrected with HRT (21,22). No effect on the epidermis could be evidenced (21,22). HRT corrects or prevents the decrease in dermal thickness and in dermal collagen content (15,16,23). These effects of HRT are systemic and do not depend on the way, oral or percutaneous, estrogens are administered. However, the previous observations of the correction of the epidermal atrophy following castration with estrogen substitution (20) were not confirmed (21,22). Estrogens may also affect skin surface lipids, epidermal hydration, sebum excretion, wrinkling and skin elasticity in postmenopausal women (24–27).

### SKIN AGING AND OTHER HORMONE REGIMENS DHEA

No effect of DHEA could be found in terms of correction or prevention of skin aging in pre or postmenopausal women (28).

## Estrogens in Topics

When topically applied to the skin, estrogens have been shown to induce a partial correction of some skin aging changes without evidence of systemic effect (29). Estriol and Estradiol ointments improved elasticity and reduced the wrinkle depth, but no control is available in this open six-month study (30). However, the effects of conjugated estrogen (Premarin<sup>®</sup> cream) were studied in a randomised, double-blind, parallel group study: 54 women applied 1 g of either Premarin cream or placebo cream to the face daily for 24 weeks (31). Skin thickness was measured by B-scan ultrasonic echography and skin micro-relief by profilometry. Skin thickness (dermal plus epidermal) increased in the treated group. Premarin was also significantly more effective than placebo in improving facial fine wrinkles. There was no effect on other parameters (skin roughness, laxity, and hyperpigmentation) (31). Topical estradiol was also shown to increase the amount of dermal collagen (32,33) and stimulate collagen synthesis (33).

## Phytoestrogens, Isoflavones

Genistein has been shown to be an inhibitor of UVR-induced skin carcinogenesis (34). The effects of isoflavones and other phytoestrogens on skin atrophy, dermal collagen are under investigation to determine their possible use in the prevention of skin aging in postmenopausal women. Animal studies showed an increased collagen metabolism in animals treated with a preparation of genistein and daizein (35).

## OTHER SKIN CARES AND MENOPAUSE

Taken together these data indicate that HRT, alone or in combinations with preparations with estrogens or isoflavones may be used to minimize skin changes due to estrogen deficiency. However, because of the possible adverse effects, such as the increased risk of breast cancer and cardiovascular disease, *HRT cannot be recommended today to treat skin aging*. On the other hand, cosmetic care has an important role to play for the menopausal woman (36). Tretinoin, glycolic acid and ascorbic acid containing products have been shown to change age and/or sun-related skin damages (37–41). They may therefore be considered as medicines, which may complement the action of HRT. Collagen injections, botulinic toxin, peeling, resurfacing laser are designed for photoinduced wrinkles and solar keratosis, conditions where HRT has no action. Surgery is necessary for cutaneous ptosis of the face and neck.

## OTHER SYMPTOMS

### Genital Discomfort

Vulvar atrophy, (Fig. 45.4) vaginal atrophy and genital dryness may be observed in postmenopausal women. Vaginal dryness may respond well to HRT. However, HRT is not effective on vulvar atrophy and topical estrogens have to be used (1,40).

### Hirsutism or Hypertrichosis

True hirsutism, if absent before menopause, is uncommon after, but facial hirsutism, or hypertrichosis is not uncommon (41). Facial hirsutism (Fig. 45.5), either in perimenopause or after the menopause, may be related to an idiopathic skin hyperandrogenism, even in the absence of biologic evidence of hyperandrogeny (2,40). Together with alopecia, excess in



Figure 45.4 Postmenopausal vulval atrophy.



Figure 45.5 Postmenopausal facial hirsutism.

seborrhea, and to a lesser degree acne, this hypertrichosis may also be related to progestin intake (either in women under HRT, or progestin therapy in premenopausal women), to DHEA, or to tibolone (42).



**Figure 45.6** Postmenopausal alopecia.

When true hirsutism, alone or with other patterns of hyperandrogenism, develops, it may correspond to an ovarian or adrenal tumor (43).

True hirsutism, but not facial hypertrichosis, responds well to antiandrogens (cyproterone acetate or spironolactone) (44). HRT has no or little effect. Facial hirsutism needs epilation (laser or any other method). Eflornithine (45), a potent inhibitor of polyamine metabolism, may also be used (Vanica<sup>®</sup> cream). The 5 $\alpha$ -reductase inhibitor finasteride was also shown to improve facial hirsutism when topically applied, with a decreased hair growth and thickness (46).

### Alopecia

Hair loss may only occur in postmenopause, alone, or in association with facial hirsutism, but is not unfrequent in premenopausal women after 40. When mild and with a progressive installation, this so-called androgenogenetic alopecia (AAG), or female-pattern hair loss (Fig. 45.6), has to be distinguished from other causes of progressive hair loss in women: hypothyroidism, iron deficiency (47), lichen planus (48) or more commonly senile alopecia (2).

Neither ERT nor HRT can prevent hair loss, and antiandrogens, such as cyproterone acetate or spironolactone, should be recommended in association with ERT and topically applied minoxidil (44,49). Finasteride that blocks the reduction of testosterone into active diOH testosterone does not prevent progression of hair loss in postmenopausal women with female-pattern hair loss (50). However the recent report of the possibility of an improvement of some AAG in postmenopausal women with hyperandrogenism supports the hypothesis that not all types of female hair loss have the same pathophysiology (51). Psychotherapy is often necessary, and in some cases hair transplantation and scalp surgery.

### OTHERS

Topically applied androgens, not estrogens, can be considered in case of genital hair loss. HRT has no effect on genital or axillary depilation. Neither HRT nor other hormonal regimens have any proved effect on postmenopausal nail changes.



**Figure 45.7** Climacteric hyperkeratosis of the palms.

Climacteric keratodermas (Fig. 45.7) are very poorly understood and no data are available concerning the effect of hormone replacement (52).

### REFERENCES

1. Faure M, Drapier-Faure E. Menopause, HRT and the skin. In: Rozenbaum H, ed. First Congress of the Federation of National European Menopause Societies. EKSA, Paris, 2001:31–35.
2. Faure M, Drapier-Faure E. Peau, phanères et stéroïdes sexuels. *Encycl Med Chir (Elsevier, Paris) Dermatologie* 12 960 A 10, 1998:1–8.
3. Bologna JL, Braverman IM, Rousseau ME. Skin changes in menopause. *Maturitas* 1989; 11:295–304.
4. Dunn LB, Damesyn M, Moore AA, et al. Does estrogen prevent skin aging? *Arch Dermatol* 1997; 133:339–342.
5. NAMS, Menopause Core Curriculum Study Guide, The North American Menopause Society, 2002, 2nd edition.
6. Meier CR, Sturkenboom MC, Cohen A, et al. Postmenopausal estrogen replacement therapy and the risk of developing systemic lupus erythematosus or discoid lupus. *J Rheumatol* 1998; 25: 1515–1519.
7. Sanchez-Guerrero J, Liang MH, Karlson EW, et al. Postmenopausal estrogen therapy and the risk for developing systemic lupus erythematosus. *Ann Intern Med* 1995; 122:430–433.
8. Arden NK, Llyod M, Spector TD, et al. Safety of hormone replacement therapy (HRT) in systemic lupus erythematosus (SLE). *Lupus* 1994; 3:11–13.
9. Kreidstein S, Urowitz MB, Gladman DD, et al. Hormone replacement therapy in systemic lupus erythematosus. *J Rheumatol* 1997; 24:2149–2152.
10. Mok CC, Lau CS, Ho CTK, et al. Safety of hormonal replacement therapy in postmenopausal patients with systemic lupus erythematosus. *Scand J Rheumatol* 1998; 27:342–346.
11. Johnston GA, Sviland L, McLelland J. Melasma of the arms associated with hormone replacement therapy *Br J Dermatol* 1998; 139:932.
12. Position statement. Estrogen and progestogen use in postmenopausal women: July 2008 position statement of the North American Menopause Society. *Menopause* 2008; 15:584–603.
13. Brincat M, Moniz CF, Kabalan SE, et al. Decline in skin collagen content and metacarpal index after the menopause and its prevention with sex hormone replacement. *Br J Obstet Gynecol* 1987; 94:126–129.

14. Brincat M, Moniz CF, Studd JWW, et al. Sex hormones and skin collagen content in post menopausal women. *Br Med J* 1983; 287:1337-1338.
15. Brincat M, Versi E, Moniz CF, et al. Skin collagen changes in postmenopausal women receiving different regimens of estrogen therapy. *Obstet Gynecol* 1987; 70:123-127.
16. Castelo-Branco C, Duran M, Gonzalez-Merlo J. Skin collagen changes related to age and hormone replacement therapy. *Maturitas* 1992; 15:113-119.
17. Castelo-Branco C, Pons F, Gratacos E, et al. Relationship between skin collagen and bone changes during aging. *Maturitas* 1994; 18:199-206.
18. Sumino H, Ichikawa S, Abe M, et al. Effects of aging and postmenopausal hypoestrogenism on skin elasticity and bone mineral density in Japanese women. *Endocrine J* 2004; 51:159-164.
19. Punnonen R, Vilksa S, Rauramo L. Skinfold thickness and long-term post-menopausal hormone therapy. *Maturitas* 1984; 5:259-262.
20. Punnonen R, Rauramo L. The effect of long-term oral oestriol succinate therapy on the skin of castrated women. *Ann Chir Gynaecol* 1977; 66:214-215.
21. Callens A, Vaillant L, Lecomte P, et al. Does hormonal skin aging exist? A study of the influence of different hormone therapy regimens on the skin of postmenopausal women using non-invasive measurement techniques. *Dermatology* 1996; 193:289-294.
22. Maheux R, Naud F, Rioux M, et al. A randomized double-blind placebo-controlled study on the effect of conjugated estrogens on skin thickness. *Am J Obstet Gynecol* 1994; 170:642-649.
23. Savvas M, Bishop J, Laurent G, et al. Type III collagen content in the skin of postmenopausal women receiving oestradiol and testosterone implants. *Br J Obstet Gynaecol* 1993; 100:154-156.
24. Guinot C, Malvy D, Ambroisine L, et al. Effets de traitements hormonaux de substitution sur des propriétés biophysiques de la peau de femmes ménopausées. *Ann Dermatol Venerol* 2002; 129:1129-1133.
25. Pierard GE, Letawe C, Dowlati A, et al. Effect of hormone replacement therapy for menopause on the mechanical properties of skin. *J Am Geriatr Soc* 1995; 43:662-665.
26. Pierard-Franchimont C, Cornil F, Dehavay J, et al. Climateric skin aging of the face—a prospective longitudinal comparative trial on the effect of oral hormone replacement therapy. *Maturitas* 1999; 32:87-93.
27. Sator PG, Sator O, Schmidt JB, et al. A prospective, randomized, double-blind, placebo-controlled study on the influence of a hormone replacement therapy on skin aging in postmenopausal women. *Climateric* 2007; 10:320-334.
28. Beaulieu EE, Thomas G, Legrain S, et al. Dehydroepiandrosterone (DHEA), DHEA sulfate, and aging: contribution of the DHEAge study to a sociobiomedical issue. *Proc Natl Acad Sci* 2000; 97:4279-4284.
29. Kainz C, Gitsch G, Stami J, et al. When applied to facial skin, does estrogen ointment have systemic effects? *Arch Gynecol Obstet* 1993; 253:71-74.
30. Schmidt JB, Binder M, Demschik G, et al. Treatment of skin aging with topical estrogen. *Int J Dermatol* 1996; 35:669-674.
31. Creidi P, Faivre B, Agache P, et al. Effect of a conjugated oestrogen (Premarin R) cream on ageing facial skin. A comparative study with a placebo cream. *Maturitas* 1994; 19:211-213.
32. Patriarca MT, Goldman KZ, dos Santos JM, et al. Effects of topical estradiol on the facial skin collagen of postmenopausal women under oral hormone therapy: a pilot study. *Eur J Obstet Gynecol Reproduct Biol* 2007; 130:202-205.
33. Varila E, Rantala I, Oikarinen A, et al. The effect of topical oestradiol on skin collagen of postmenopausal women. *Br J Obstet Gynaecol* 1995; 102:985-989.
34. Wei H. Photoprotective action of isoflavone genistein; models, mechanisms and relevance to clinical dermatology. *J Am Acad Dermatol* 1998; 39:271-272.
35. Simeon A, Macquart FX, Cohen-Letessier A. Effet d'une préparation à usage topique contenant de l'extrait titré de Soja à 5%, de l'extrait titré de Centella asiatica à 1% et l'association des deux dans le vieillissement cutané chez l'animal. *Nouv Dermatol* 2000; 19:636-640.
36. Gilchrist BA. A review of skin ageing and its medical therapy. *Br J Dermatol* 1996; 135:867-875.
37. Kligman AM, Grove GL, Hirose R, et al. Topical tretinoin for photoaged skin. *J Am Acad Dermatol* 1986; 15:836-859.
38. Creidi P, Humbert P. Clinical use of topical retinaldehyde on photoaged skin. *Dermatology* 1999; 199(S1):49-52.
39. Nusgens BV, Humbert P, Rougier A, et al. Topically applied vitamin C enhances the mRNA level of collagens I and III, their processing enzymes and tissue inhibitor of matrix metalloproteinase 1 in the human dermis. *J Invest Dermatol* 2001; 116:853-859.
40. Faure M, Drapier-Faure E. Effets bénéfiques des traitements hormonaux en cosmétologie. *Encycl Med Chir (Editions Scientifiques et Medicales Elsevier SAS, Paris), Cosmétique et Dermatologie Esthétique*, 50-240-B-10, 2001, 5.
41. Moses RG, Theile H, Colagiuri S. Postmenopausal idiopathic hirsutism. *Menopause* 1994; 1:205-209.
42. Modelska K, Cummings S. Tibolone for postmenopausal women: systematic review of randomized trials. *J Clin Endocrinol Metab* 2002; 87:16-23.
43. Conn JJ, Conway GS. Severe virilization in a postmenopausal woman. *Curr Opin Obstet Gynecol* 1996; 8:385-389.
44. Faure M, Drapier-Faure E. La prise en charge des hyperandrogénies. *Ann Dermatol Venerol* 1998; 125:533-540.
45. Hamzavi I, Tan E, Shapiro J, et al. A randomized bilateral vehicle-controlled study of eflornithine cream combined with laser treatment versus laser treatment alone for facial hirsutism in women. *J Am Acad Dermatol* 2007; 57:54-59.
46. Lucas KJ. Finasteride cream in hirsutism. *Endocr Pract* 2001; 7:5-10.
47. Rushton DH, Ramsay ID. The importance of adequate serum ferritin levels during oral cyproterone acetate and ethinylestradiol treatment of diffuse androgen dependent alopecia in women. *Clin Endocrinol* 1992; 36:421-427.
48. Kossard S, Lee MS, Wilkinson B. Post-menopausal frontal fibrosing alopecia: a frontal variant of lichen planopilaris. *J Am Acad Dermatol* 1997; 36:59-66.
49. Vexiau P, Chaspoux C, Boudou P, et al. Effects of minoxidil 2% vs. Cyproterone acetate treatment on female androgenetic alopecia: a controlled, 12-month randomized trial. *Br J Dermatol* 2002; 146:992-999.
50. Price VH, Roberts JL, Hordinsky M, et al. Lack of efficacy of finasteride in postmenopausal women with androgenetic alopecia. *J Am Acad Dermatol* 2000; 43:768-776.
51. Shum KW, Cullen DR, Messenger AG. Hair loss in women with hyperandrogenism: four cases responding to finasteride. *J Am Acad Dermatol* 2002; 47:737-739.
52. Hawthausen H. Keratoderma climatericum. *Br J Dermatol* 1934; 46:161-167.



## Mesotherapy

Evangeline B. Handog and Ma. Teresita G. Gabriel

### INTRODUCTION

With the advent of the 20th century, fat reduction, cellulite removal, body sculpting, face and neck rejuvenation, hair loss, alopecia, pain management for sports injuries, tendonitis, bursitis, and osteoarthritis have been approached with minimally invasive medical techniques. One modality that was first introduced in 1952 by Dr Michel Pistor, a French physician, is called mesotherapy. In his small village of Bray-lu, France, Dr Pistor attempted to abort an acute asthma attack in a patient by administering 10 mL of procaine intravenously. While the treatment did not ameliorate the patient's respiratory status, upon follow-up, the patient reported a significant improvement in his impaired hearing. Soon thereafter, Dr Pistor began experimenting with superficial injections of procaine around the ears of hearing-impaired patients and experienced some success (1). With this new knowledge, he moved to Paris, and in 1958, presented the first publication on the subject, wherein he proposed the name "mesotherapy" for this procedure. In 1964, his professor and friend, the medical surgeon Lebel, invented the small needle that carries his name and recommended the creation of The French Society of Mesotherapy, which Pistor started that same year (2).

Mesotherapy is derived from the Greek words *mesos* meaning "middle" and *therapeia*, "to treat medically." It is a form of treatment that involves injecting tiny amounts of a substance into the mesoderm, which is the embryonic middle layer located between the ectoderm and endoderm. Depending on the indication, each session may involve several injections administered at various skin levels by syringe or specially engineered delivery guns. It is thought that the injection of certain substances can either dissolve underlying fat or cause healing by other mechanisms. It is virtually painless, requires no postoperative recovery time, heavy bandages or girdles, and anesthesia. The injected solution is individually prepared depending on its purpose and is administered directly to the desired area. This limits side effects, reduces the possibility of drug interactions, and allows for a substantial reduction in the amount of medicine utilized for each procedure. Although other surgical procedures may require one to two weeks of recovery, patients undergoing mesotherapy have no disruptions in their daily activities.

The first international conference on mesotherapy took place in 1976. At that same year, mesotherapy was first used in in-patient settings in France. In 1981, Dr Jacques Le Coz introduced mesotherapy at the orthopedic clinic of the Institut National du Sports (National Institute of Sports) in Paris. In 1987, the French Academy of Medicine officially recognized mesotherapy as a legitimate treatment modality within conventional medicine (3).

Mesotherapy was popularized for medical therapy in Europe and South America as a method of utilizing cutaneous injections containing a mixture of compounds for the treatment of local medical and cosmetic conditions. Although mesotherapy was traditionally employed for pain relief, its cosmetic applications as a form of fat and cellulite removal have recently received attention in the United States.

Mesotherapy received its initial advance into the American consciousness when a popular American singer cited that mesotherapy, combined with a comprehensive diet and exercise work. Dr. Lionel Bissoon, an osteopathic physician, was responsible for her dramatically improved appearance (4). "Wellness centers" and "medical spas" in the United States have embraced mesotherapy as a novel treatment for cellulite, fat loss, and photoaging (5).

Mesotherapy has been categorized depending on the objective, depth of injection, and the kinds of solutions to be used.

Handog and Legaspi-Viscerra defined Mesolift as a mesotherapy procedure that helps decrease wrinkles and "crepe skin" in the facial and décolleté areas, improve skin tone and texture, enhance skin contour, and subtly lift sagging skin in the face and neck. It may not be a substitute for face lift, but it offers an alternative method for facial rejuvenation. A combination of hyaluronic acid, highly concentrated vitamins, trace elements, coenzymes, amino acids, and antioxidants is delivered into the skin to nourish and rejuvenate, promote production of collagen and elastin, and stimulate metabolism. This is aimed at improving blood circulation in the skin, further strengthening its structure and restoring its firmness (6).

To even out skin color and improve complexion, specific cocktails of vitamins and antioxidants are utilized. This is called Mesoglow. Dull skin turns healthy and glowing. Collagen and elastin production are expected benefits of the anti-aging ingredients (6).

The injection of phosphatidylcholine singly or in combination to effect weight loss, to remove localized adiposities, cellulite, and contour-specific undesired fat pockets, is called Mesosculpt. The face, neck, abdomen, thighs, buttocks, and arms are areas that can benefit from Mesosculpting (Fig. 46.1) (6).

An alternative to liposuction, mesolipotherapy, which is by far the most popular mesotherapy procedure, can be used to contour the different parts of the body. It works by removing fat from adipose tissue without completely destroying it. Phosphatidylcholine is the most thoroughly researched medication used in mesolipotherapy (7).

Vedamurthy reports a needleless mesotherapy technique using ultrasound or iontophoresis that delivers mesotherapy



**Figure 46.1** (A) Patient before mesosculpture; (B) two and a half weeks after mesosculpture. *Source:* Courtesy of Dr Ma Encarnacion Lagaspi-Vicerra.

products. Although this is practically painless, there is only 20% efficacy as compared with the traditional mesotherapy (8).

### SCIENTIFIC RATIONALE

#### Pistorian Reflex Theory

There are a number of theories proposed to explain how mesotherapy could possibly work. According to Dr Pistor, the direct pharmacological action of the drugs administered locally or regionally is not enough to explain the results obtained in pathologies, which is located in the deep organs. He thinks that the skin could be a projection of different internal locations of deep organs, which can be mapped out as in acupuncture. This suggests a correlation between a pathology and its cutaneous representation. According to this reflex theory, mesotherapy has an inhibitory stimuli originating at the dermal level. This interrupts the visceral-medullar-cerebral path at the lateral medullar level where the vegetative system is connected to the cerebral-spinal system. These inhibitory stimuli can be both mechanical, that provoked by the needle, and physiochemical-pharmacological, that which is due to the medicines administered through the needle. This represents a localized “shock” on the lateral-medullar sympathetic center. Lichwitz in his 1929 thesis showed that vegetative, medullar, and cerebral reactions maybe produced depending on the substance injected at the dermal level. Few chemical products and small doses may

even be capable of producing significant results based on this concept (9).

#### Bicheron’s Microcirculatory Theory

Drugs administered locally or regionally may produce a stimulating effect on the local microcirculation. This may be altered by the lesion. Microcirculatory vascular damage may arise from a diseased organ, tendon, or articulation, which further aggravates the problem. Thermographic studies reveal alterations before and after treatment. This is the rationale behind mesotherapy’s actions in diverse pathologies such as cephalgias, rachialgia, degenerative osteoarticular disease, vascular acrosyndromes, or cellulite (10).

#### Mesodermic Theory

This theory applies to the treatment of connective tissues originating from the mesoderm such as the skin, bone, and cartilage.

According to the mesodermic theory, three units are involved:

1. The microcirculatory unit comprises of the small capillary and venous spaces that ensure blood interchange as well as the transport of the secretions from the connective tissue cells and the medications introduced via the mesoderm.

2. The neural-vegetative unit is the element of the sympathetic system that exists in the dermis, which is responsible for achieving the regulation of the nervous system.
3. The immunological aspect unit consists of the connective tissue that generates defense zones with specialized cells, the plasmocytes and mastocytes. These cells respond to the penetration of a product through the skin, which explains the influence of mesotherapy on the immunological system (10).

### Third Circulation Theory

There are three compartments: namely, the blood circulation as the first, the lymphatic system being the second, and the interstitial compartment, known as the third circulation, which is the area for mesotherapy. A process mediated by procaine, with its membrane-stabilizing action, in some way retards the passage of medicines to the lymphatic and venous capillaries. Medications would be delivered through the interstitial space to the deepest tissues and reach the target site without loss due to absorption by vessels, hence achieving the highest concentration. This will explain how mesotherapy can have a therapeutic effect even with minimal doses (10).

### Benefits and Advantages of the Method

Mesotherapy enhances therapeutic efficacy when treating diseases locally. It is possible to administer allopathic microdoses, hence reducing the required quantity needed. Since the required dose is lower than the conventional dose, this would mean lesser iatrogenic side effects. Overall, there will be fewer therapeutic sessions (11).

### TECHNIQUES

Handog and Legaspi-Viscerra in the *Handbook of Cosmetic Skin Care*, 2nd edition, enumerated the different techniques for mesotherapy. These includes intraepidermal (tremor), superficial intradermic (multipricking), deep intradermic (point per point), and intrahypodermic.

Intraepidermal techniques, intended for facial rejuvenation, refer to injecting the mesotherapeutic agents into the epidermis using rapid fine movements. A 13-mm needle (30G) is used for this injection technique. The needle is placed tangentially on the skin with the bevel facing upward. Multiple small punctures on the epidermis at a depth not exceeding 1 mm are performed with quick synchronized flicking movements of the practitioner's wrist. Mastery of the technique is important to prevent accidental skin abrasions and bleeding. Mesotherapy injections at two-week intervals for a total of 10 treatments are recommended (7).

Superficial intradermic or multipricking method, mainly used for treatment of cellulite, refers to the injection of mesotherapeutic agents into the dermis by multiple rapid injections using a 4- or 6-mm needle. It is also called superficial pricking "nappage bouncing" and was given the name "Parkinsonian sprinkling" technique by Dr Pistor, who described a slight bouncing action of the wrist. The practitioner performs quick needle pricks on the skin at a rate of 10 punctures/sec without dragging the needle on the skin between punctures. The punctures are spaced between 2 and 4 mm apart. Another method known as dry mesotherapy technique may be carried out without any substance in the syringe. This technique is used for chronic painful episodes or for treatment of rebound

effects after a mesotherapy session. On the contrary, wet mesotherapy wherein there is a substance in the syringe may cause cutaneous stimulations by applying a few drops of an active substance on the skin before nappage. Mesotherapy injections done weekly for 10 to 15 visits are recommended. This maybe tapered off to once a month for maintenance treatment (7).

Another way of doing mesotherapy uses superficial injection utilizing point-by-point technique (PPP). In this technique, a traditional intradermal type of injection is done by injecting between 0.05 and 0.1 mL of a substance at each point. Nappage technique may be carried out on dry skin, followed by deposits of a few drops of the substance into it. The product is then massaged into the skin. Alternatively, a patch may be used. It is possible to use the last two techniques on children for microvaccination sessions (12). In the nappage technique, there are multiple injections on the skin to a depth of 0.5 to 2 mm with the needle placed at an angle of 45° to the skin. Nappage technique allows the injection of the medication into the target lesion based on the knowledge that normally only one-third of the dose will reach its target.

The deep intradermal injection technique, used for arthritis and tendonitis, refers to the injection of mesotherapeutic agents into the dermis using a 4-mm needle directed to the areas that are inflamed (7). Injections are administered at a depth of 1 to 3 mm without papule formation, and the dosage can vary from 0.1 to 0.2 mL per point.

Intrahypodermic injections, used for low back pain or musculoskeletal pain, refer to the injection of mesotherapeutic agents into the subcutaneous layer using a 13-mm needle (7).

Injections can vary in depth from 4 to 13 mm depending on the location. The various depths of the needle injections are based on the indications (12).

### PRODUCTS

There is no standardized formulation for mesotherapy, and active ingredients vary depending on indications. One of the ingredients most consistently used for fat loss is a soybean lecithin extract, phosphatidylcholine. Initially it was thought that this was the responsible agent for the nonspecific lysis of cell membranes resulting in fat reduction. It can alter cholesterol and other triglyceride metabolism and appears to increase cholesterol solubility (13). However, recent data suggests that the cell lysis may in fact be due to the action of deoxycholate, a natural detergent used in these formulations to keep the phosphatidylcholine soluble in water.

Other products available in the market may also be used in mesotherapy. The following substances are used for Mesolift and Mesoglow treatment.

- Vitamin A acts by regulating the growth of epidermal cells and helps restore collagen and elastin.
- Vitamin B5, which is involved in the cellular production of energy, is needed for hormone synthesis.
- Vitamin C helps stimulate synthesis of collagen and inhibits synthesis of melanin.
- Vitamin D is necessary for the synthesis of calcium.
- Vitamin E, being an antioxidant, fights the formation of toxic peroxides.
- Vitamin K plays a major role in regulation of microcirculation.
- Amino acids are the basis of tissue architecture of the skin.

- Silica is important in maintaining the ceramide matrix.
- Zinc protects against free radicals and is needed in the body repair process.
- Coenzyme Q10, an antioxidant, protects against free radicals and assists in energy production and healing.
- Cytokines Epidermal Growth Factor (EGF), Basic Fibroblast Growth Factor (BFGF) stimulate the cell functions of aged skin.
- Copper peptide increases the biosynthesis of collagen and elastin. It also increases the body's natural tissue building process and helps firm, smooth, and soften the skin. Nucleic acids stimulate synthesis while the reducing agent glutathione acts as a super antioxidant. Superoxide dismutase prevents melasma, while Argireline helps in wrinkle reduction.

A number of solutions are being used for Mesosculpt.

- Phosphatidylcholine, derived from natural soy lecithin, is an excellent fat burner altering the metabolism of fatty substances like cholesterol and triglycerides in the body.
- Hyaluronidase is being used in combination with other injectable drugs to increase their absorption and dispersion. It breaks down hyaluronic acid and may help to break down the connective tissue bands that create the dimpled appearance of cellulite.
- L-Carnitine is required for fatty acids to be delivered into the cells where the fat can be burned as a source of fuel.
- Artichoke acts as a diuretic and stimulates the lymphatic draining system. When used in crude form (20 mg/mL), it can cause local necrosis.
- EGCG (epigallocatechin gallate), another antioxidant derived from green tea, inhibits an enzyme that destroys norepinephrine. It increases metabolic rate and uses fat as energy source.
- Caffeine is an alkaloid that increases blood flow and stimulates the fat cells to release fat to the blood stream to be burned by the body's metabolism. It acts to drain the fat cells and tightens and tones the skin.
- Aminophylline stimulates the release of fat into the bloodstream. It is as effective as caffeine, although less stable and must be kept in a cool place.
- Yohimbine (lombina), an alkaloid found in the inner bark of a tree growing in South Africa, *Corynanthe yohimbe*, is excellent for targeting localized fat. It is an  $\alpha 2$  antagonist having a lipolytic effect and potentiating  $\beta$ -receptor activation. It has been primarily used for lower body fat in females and abdominal fat in males.
- Triiodothyroacetic acid is an excellent fat burner. Phosphatidylcholine and deoxycholate act as detergents causing adipose cell walls to dissolve and break down, thereby leading to shrinkage of fat cells. The immune system removes cellular debris from the broken cell wall. The body excretes it through the lymphatic system (12).

## OTHER PRODUCTS

Organic silicium acts by increasing collagen production. CRP 1000 has cytokines for cellular stimulation and copper peptide that improves collagen and elastin synthesis. Hyaluronic acid is a substance that improves hydration. A number of chemicals acting as antioxidants and are claimed to decrease pigmentation are also currently being used for mesotherapy. These are glutathione, ascorbic acid, glycolic acid, and calcium pyruvate.

Chemicals used to stimulate hair growth like buflomedial, minoxidil, and finasteride are other options. Vitamin C is used for hyperpigmentation and melasma and acts as an antioxidant and helps in collagen and elastin production. Vitamin A used as antiaging treatment to improve fine lines, biotin used in the treatment of alopecia, and minerals such as copper peptide used for increasing the skin elasticity are also being utilized for this procedure.

Antibiotics, caffeine, aminophylline, carnitine, hormones such as calcitonin and thyroxin,  $\beta$ -agonist, ephedrine, isoproterenol, enzymes such as collagenase and hyaluronidase, and herbal extracts are likewise being used.

## INDICATIONS

The general indications of mesotherapy include the following:

1. Sports injuries: Arthropathy, muscle tear, stress fractures, tendon strain, meniscal tear, plantar fasciitis, tendon calcification, tendon degeneration, and tendon strain.
2. Chronic painful conditions: Bone spurs, carpal tunnel syndrome, chronic low back pain contractures, degenerative arthritis, fibromyalgia, frozen shoulder, ulnar neuropathy, degenerative arthritis, gout, herniated disc pain, and neuralgia.
3. General medical conditions: Allergies, alopecia, asthma, autoimmune disease, bronchitis, coronary insufficiency, degenerative arthritis, obesity, vascular insufficiency, and vertigo.
4. Skin conditions: Acne, alopecia, cellulite, contusions, eczema, keloids, male/female hair loss, obesity, scar, telangiectasia, vitiligo, wrinkles, and hyperpigmentation (6).

The aesthetic indications of mesotherapy include face and neck rejuvenation, improving skin texture and appearance, firming the skin, wrinkle treatment, cellulite and "dimpled" skin, localized adiposities, body sculpting, and hair loss or alopecia (6).

Other benefits of mesotherapy include improved blood flow to the area, removing fibrotic hardened connective tissue, improved lymphatic drainage, no downtime.

## CONTRAINDICATIONS

The contraindications to mesotherapy are observed in patients who are pregnant or breast-feeding; insulin-dependent diabetics; patients suffering from or with a history of cancer; patients with blood dyscrasias; patients receiving anticoagulants; and patients on multiple heart medications, with cardiovascular disease, or with previous history of cardiovascular accident.

## ADVERSE REACTIONS/COMPLICATIONS

Mesotherapy, in general, has very few side effects. Because mesotherapy is administered directly to the desired area, it is believed that side effects are limited or reduced. Patients undergoing mesotherapy may resume their normal activities immediately. Unlike liposuction, mesotherapy does not require restrictive garments and usually causes only slight bruising that resolves in one week (Fig. 46.2). Swelling from mesotherapy is mild and lasts a day or two, and some patients may notice slight itchiness or soreness for two to three hours after the procedure.

Adverse effects depend on the product used. Skin necrosis can occur due to the irritant effect of the chemicals used.



**Figure 46.2** One complication of mesotherapy is bruising and hematoma.

Liver toxicity and demyelination of nerves have been reported with large doses of phosphatidylcholine. Atypical mycobacterial infection is a rare complication at injection sites necessitating antimycobacterial therapy. These reports were largely due to nonsterile techniques. Infections may become a serious problem because the drug is not being administered by physicians.

Localized adverse events have included irregular contours and tender subcutaneous nodules. Urticarial and lichenoid reactions to the injected medications as well as mycobacterial infections have been reported in the literature.

Systemic side effects of phosphatidylcholine include mild transient elevations in liver function tests and rare cases of nausea and vomiting after injections of high volumes. Additional side effects of mesotherapy include immediate or delayed allergic reaction to the injected drugs or solutions. For example, lecithin is known to cause inflammation and swelling, skin infections, pigmentation at the injection site, bruising at the injection site, ulceration and scarring at the injection site, and panniculitis.

Davis reports two cases of noninfectious granulomatous panniculitis following mesotherapy injection. In the first case, the injection solution contained deoxycholate, and in the second case, the injection solution was unknown. In both cases, the solutions were administered by multiple injections to the subcutaneous adipose. Within two months, both patients developed numerous erythematous to violaceous, tender, subcutaneous nodules at the injection sites. All tissue cultures were negative. One subject improved with dapsone treatment, while the other with etanercept. Permanent hyperpigmented scars persisted in both individuals (14).

Mesotherapy has recently become an advertised method for the treatment of different types of alopecia despite the lack of any data regarding its efficacy and possible side effects. The substances injected into the scalp include "cocktails" of natural plant extracts, homoeopathic agents, vitamins, vasodilators, and drugs that may stimulate hair growth, such as finasteride and minoxidil. Duque-Estrada et al. report two cases of patchy alopecia that developed after mesotherapy for the treatment of androgenetic alopecia (15).

Outbreaks of rapidly growing mycobacteria have been occasionally described. The article reports an outbreak of cutaneous abscesses due to *Mycobacterium chelonae* following mesotherapy in Lima, Peru. From December 2004 through January 2005, 35 subjects who had participated in mesotherapy training sessions presented with persistent cutaneous abscesses. Thirteen (37%) of these suspected cases underwent complete clinical examination. Skin punch biopsies were collected from suspicious lesions, and substances injected during mesotherapy were analyzed. Suspected cases were mainly young women, and lesions included subcutaneous nodules, abscesses, and ulcers. *M. chelonae* was isolated from four patients and from a procaine vial. It has been concluded that it is important to consider mesotherapy as a potential source of rapidly growing mycobacterial infections (16).

Carbonne et al. describe an outbreak of severe subcutaneous infections due to nontuberculous mycobacteria following mesotherapy. Epidemiological studies and molecular comparisons of *M. chelonae* strains from different patients and the environment suggested that contamination may be associated with inappropriate cleaning of the multiple-injection device with tap water (17). Mesotherapy is a popular procedure that poses risks that include scarring, contour changes, and bacterial infections. Beer and Waibel report a case of mycobacterial infection from *M. cosmeticum* resulting from mesotherapy. This infection should be considered when a patient consults with a mesotherapy complication, and the possibility of developing mycobacterial infections should be discussed with the patient prior to the procedure (18).

Mesotherapy consists of cutaneous injections of a mixture of compounds and has recently been used for cosmetic purposes to reduce local fat and cellulite. To date, several reports have described only local adverse events related to this therapy. Danilovic et al. describe the first report of a female patient who developed thyrotoxicosis due to cosmetic mesotherapy with triiodothyroacetic acid in its formulation. A disturbance of type III deiodinase activity or skin fibroblast paracrine function and vascular alterations related to simultaneously injected vasoactive compounds were observed apart from the mechanical rupture of the epidermal barrier. These findings could be related to thyroid hormone metabolite absorption and systemic consequences in the reported case. This case of factitious thyrotoxicosis induced by mesotherapy was reported to raise awareness of a systemic adverse effect resulting from this widespread cosmetic practice (19).

Kadry et al. report a case of multifocal scalp abscess with subcutaneous fat necrosis and scarring alopecia as a direct result of mesotherapy requiring extensive surgical repair (20).

Panniculitis is a rare adverse reaction to mesotherapy that may result from injection pressure, local trauma, or the type of injected substances. Tan et al. report a case of mesotherapy-induced panniculitis successfully treated with dapsone. This case shows that one of the potential adverse effects of mesotherapy is panniculitis and suggests that dapsone is an effective treatment for this condition (21).

Infectious complications following mesotherapy are usually due to ordinary bacteria or atypical mycobacteria. Marco-Bonnet et al. report two new cases of mycobacterium bovis BCG infections following mesotherapy. A 52-year-old woman developed vaccinal MERIEUX BCG cutaneous abscesses following mesotherapy. Identification was made by a novel class of repeated sequences using mycobacterial interspersed repetitive units. Although patient received prolonged antituberculous

therapy, complete remission was not obtained and surgical excision was performed. The second case was a 49-year-old man who developed a mycobacterial bovis BCG cutaneous abscess (Connaught) after mesotherapy. There was regression of the lesion with antituberculous therapy. Severe mycobacterial infections observed in these two patients following mesotherapy should always be kept in mind. Identification of etiological agent is made possible by molecular biology techniques like PCR and sequencing. Some authors recommend antituberculous therapy, but surgical excision may be necessary as in the first case (22). Cutaneous infections caused by *M. fortuitum* usually are a complication of trauma or postsurgical wounds. A 41-year-old woman presented with numerous dusky red nodules, abscesses, and sinuses on the right buttock and on the lateral surfaces of both thighs. The lesions developed at the injection sites of mesotherapy treatment. *M. fortuitum* was cultured from a biopsy specimen and purulent fluid drained from lesions. The lesions had cleared completely with ciprofloxacin 500 mg b.d. for three weeks, and then 250 mg b.d. for another three weeks. This case demonstrates the importance of suspecting mycobacterial etiology in patients with nodules and abscesses in the areas of mesotherapy treatment (23). Benign symmetric lipomatosis, also known as Madelung disease, is a rare disorder characterized by fat distribution around the shoulders, arms, and neck in the context of chronic alcoholism. Complete excision of nonencapsulated lipomas is difficult. However, reports describing conservative therapeutic measures for lipomatosis are rare. The authors present the case of a 42-year-old man with a diagnosis of benign symmetric lipomatosis who had multiple, large, symmetrical masses in his neck. Multiple phosphatidylcholine injections in the neck were administered four weeks apart, a total of seven times to achieve lipolysis. The patient's lipomatosis improved in response to the injections, and he achieved good cosmetic results. Intraleisional injection, termed mesotherapy, using phosphatidylcholine is a potentially effective therapy for benign symmetric lipomatosis that should be reconsidered as a therapeutic option for this disease (24). Phern-Chern et al. report a case of a 40-year-old professional woman who developed episodes of delirium after 8 to 12 hours of undergoing bilateral mesotherapy of both thighs. This was her first mesotherapy treatment. She felt well during and immediately after the injections. She had no past personal or family history of psychiatric disorders or substance abuse, no significant past medical, surgical, or travel history, so this was the first such episode for her. She was not on any hypnotic or other medications and denied alcohol use. Extensive workup, including brain imaging and a large panel of laboratory investigations, were all within normal limits. She was admitted to the psychiatry inpatient service. After two days of close observation but without any medications, she was discharged with no residual symptoms. In this patient, we did not know the contents of the injection. It is possible that the injected substance (s) crossed the blood-brain barrier and had direct effects on the brain substrate. Literature search have not shown any report of psychiatric symptoms associated with mesotherapy. More controlled studies on the safety of mesotherapy are highly recommended (25).

Nabavi et al. describe a case of a 67-year-old man who developed acute orbital inflammation after receiving cosmetic mesotherapy (lipodissolve) to the inferior orbital fat compartments. The injection was intended to cause lipolysis and shrinkage of fat lobules with subsequent cosmetic improvement. Injections of a mixture of bile salts, phospholipid, and alcohol preservative bilaterally in inferior orbital fat lobules led to an

acute inflammatory reaction characterized histologically 12 days later consisting of mild lymphocytic infiltration, fat necrosis, and fibrosis in the target areas. Benign proliferation of peripheral nerve trunks consistent with a traumatic neuroma was also noted histologically on one side. Inflammation including fat necrosis and traumatic neuroma are all possible consequences of mesotherapy and should not be always considered (26).

Rivera-Olivero et al. describe the clinical and epidemiological characteristics, microbiological diagnosis, treatment and follow-up of patients from Caracas, Venezuela with soft tissue infection caused by nontuberculous mycobacteria following mesotherapy. Between March 2002 and December 2003, they evaluated 49 cases of skin and soft tissue infection following mesotherapy. Specimens obtained from the lesions and 15 products used in the mesotherapy procedure were cultured for the presence of nontuberculous mycobacteria. Isolated mycobacteria were identified by PCR restriction fragment length polymorphism analysis of the hsp65 gene. Infection by nontuberculous mycobacteria was confirmed in 81.6% of the 49 cases. *M. abscessus* and *M. fortuitum* were the most common species, but *M. chelonae*, *M. peregrinum*, *M. simiae*, and a new species that was designated "*M. cosmeticum*" were also isolated. Patients were treated with species-specific antibiotic agents for 3 to 18 months. Investigation into the source of the infection revealed that 21 patients were clustered within 3 different outbreaks, and two products were found to be contaminated with *M. fortuitum* and *M. abscessus*, respectively. Physicians should be alerted to the possibility of infection by nontuberculous mycobacteria in patients with a history of mesotherapy who develop late-onset skin and soft tissue infection, particularly if they do not respond to conventional antibiotic treatment (27).

There are alarming complications of mesotherapy that needs to be discussed with the patients prior to the procedure. Aseptic technique is mandatory and should be strictly enforced to avoid these unwanted complications.

## CONTROVERSIES

There are issues and concerns regarding the lack of standardization of solutions being used for mesotherapy. As this procedure has gained popularity in spas and facial centers, sepsis maybe encountered and poses a grave threat to the patients' health as a whole. In the United States, there is still no FDA approval for the active ingredients used in the injectables. Histological effects to validate the supposedly benefits of this procedure are not yet available and needs further investigations. Longevity and efficacy of the results of the procedure is undetermined and warrants further evaluation. Recommendations regarding the maintenance schedule of mesotherapy will largely depend on the results of large-scale comprehensive studies.

## REFERENCES

1. Adelson H. French mesotherapy for the treatment of pain. *Am J Mesother* 2005; 3:11-36.
2. Curri SB. Las paniculopatias de estasis venosa: diagnostico clinico e instrumental. Barcelona: Hausmann. 1991; 211.
3. Le Coz. Mesotherapie in Medecine Generale. Singapore: Masson, 1993.
4. Bossy J. Bases neurobiologiques des reflexotherapies. Paris: Masson, 1983.

5. Rotunda AM, Kolodney MS. Mesotherapy and phosphatidylcholine injections: historical clarification and review. *Dermatol Surg* 2006; 32:465–480.
6. Handog EB, Legaspi-Viscerra ME. Mesolift, mesoglow, meso-sculp: is there a difference? In: Tosti, De Padova, eds. *Atlas of Mesotherapy in Skin Rejuvenation*. United Kingdom: Informa Health Care, 2007:101–115.
7. Handog EB, Legaspi-Viscerra ME. Mesotherapy. In: Shai A, Maibach HI, Baran R, eds. *Handbook of Cosmetic Skin Care*. 2nd ed. United Kingdom: Informa UK Ltd, 2009:207–211.
8. Vedamurthy M. Mesotherapy. *Indian J Dermatol Venereol Leprol* 2007; 73:60–62.
9. Pinto R, Saenger-Ruiz F, Govantes-Lopez P. Celulitis. *Paniculopatia Edemato Fibro-Esclerotica*. New York: Taylor & Francis, March, 1995.
10. Leibaschoff G, Steiner D. Action mechanism of mesotherapy. In: Goldman MP, Bacci PA, Leibaschoff G, et al. eds. *Cellulite: Pathophysiology and Treatment*. New York: Taylor & Francis Group, 2006:263–286.
11. Corbel D. Mesoterapia (ID Terapia) y Celulitis. In: Masson ed, New York: Taylor & Francis, November, 1992.
12. Le Coz J, Vinh LV. *Mesotherapy & Lipolysis: A Comprehensive Clinical Approach*. Singapore: Esthetic Medic Pte Ltd, 2008.
13. Hexsel D, Serra M, Mazzuco R, et al. Phosphatidylcholine in the treatment of localized fat. *J Drugs Dermatol* 2003; 2:511–518.
14. Davis M. Noninfectious granulomatous panniculitis: a complication of mesotherapy—two cases and a review. *J Am Acad Dermatol* 2009; AB188.
15. Duque-Estrada B, Vincenzi C, Misciali C, et al. Alopecia secondary to mesotherapy. *J Am Acad Dermatol* 2009; 61(4): 707–709.
16. Munayco CV, Grijalva CG, Culqui DR, et al. Outbreak of persistent cutaneous abscesses due to *Mycobacterium chelonae* after mesotherapy sessions. *Rev Saúde Pública* 2008; 42(1):146–149.
17. Carbonne A, Brossier F, Arnaud I. Outbreak of nontuberculous mycobacterial subcutaneous infections related to multiple mesotherapy injections. *J Clin Microbiol* 2009; 47(6):1961–1964.
18. Beer K, Waibel J. Disfiguring scarring following mesotherapy-associated *Mycobacterium cosmeticum* infection. *J Drugs Dermatol* 2009; 8(4):391–393.
19. Danilovic DL, Bloise W, Knobel M, et al. Factitious thyrotoxicosis induced by mesotherapy: a case report. *Thyroid* 2008; 18(6):655–657.
20. Kadry R, Hamadah I, Al-Issa A, et al. Multifocal scalp abscess with subcutaneous fat necrosis and scarring alopecia as a complication of scalp mesotherapy. *J Drugs Dermatol* 2008; 7(1):72–73.
21. Tan J, Rao BJ. Mesotherapy-induced panniculitis treated with dapsone: case report and review of reported adverse effects of mesotherapy. *Cutan Med Surg* 2006; 10(2):92–95.
22. Marco-Bonnet J, Beylot-Barry M, Texier-Maugein J, et al. Mycobacterial bovis BCG cutaneous infections following mesotherapy: 2 cases. *Ann Dermatol Venereol* 2002; 129:728–731.
23. Difonzo EM, Campanile GL, Vanzi L, et al. Mesotherapy and cutaneous *Mycobacterium fortuitum* infection. *Int J Dermatol* 2009; 48(6):645–647.
24. Hasegawa T, Matsukura T, Ikeda S. Mesotherapy for benign symmetric lipomatosis. *Aesthetic Plast Surg* 2009; 34(2):153–156.
25. Phern-Chern T, and Tih-Shih L. Delirium with psychotic features possibly associated with mesotherapy. *Psychosomatics* 2008; 49:273–274.
26. Nabavi CB, Minckler DS, Tao JP. Histologic features of mesotherapy-induced orbital fat inflammation. *Ophthalm Plast Reconstr Surg* 2009; 25(1):69–70.
27. Rivera-Olivero IA, Guevara A, Escalona A, et al. Soft-tissue infections due to non-tuberculous mycobacteria following mesotherapy. What is the price of beauty. *Enferm Infecc Microbiol Clin* 2006; 24(5):302–306.

## Microneedles and cosmetics

Raja K. Sivamani and Howard I. Maibach

### INTRODUCTION

The field of transdermal drug delivery has significantly advanced over the past decade (1). Traditionally, drugs are delivered either orally or through the use of a hypodermic needle, but both have significant drawbacks. Oral drug delivery is affected by the acidity of the stomach, poor intestinal absorption, and first-pass hepatic metabolism, which all contribute to lower bioavailability. Hypodermic needles are painful, which lead to patient discomfort. Transdermal drug delivery is an alternative delivery method that introduces drugs by bypassing the skin barrier to allow for either systemic or local drug delivery. Unlike hypodermic needles, transdermal drug delivery does not mechanically penetrate as deeply.

A major barrier in transdermal drug delivery is the stratum corneum. It is the outermost layer of skin that is approximately 15  $\mu\text{m}$  in thickness and is composed of keratinized dead cells. Transdermal drug delivery systems aim to bypass the stratum corneum since it is usually the rate-limiting barrier in transdermal delivery. The stratum corneum is lipophilic in nature and is resistant to the passage of hydrophilic substances or the passage of molecules that are larger than a few hundred daltons. In general, three different approaches are taken to bypass the stratum corneum (1). The first approach is to depend on passive diffusion of topically applied products, and this in principle is utilized by many of the transdermal patches. A limitation to this approach is that only drugs that are low in molecular weight and lipophilic are best suited. The second approach is to actively aid drug movement during topical application. This is done through temporary disruption of the stratum corneum, acceleration of drug travel time, or a combination of both. Some examples include the use of liposomes and iontophoresis. The third approach is to create physical conduits or channels through the stratum corneum, as is done by microneedles.

### MICRONEEDLE FABRICATION

Microneedles are miniature needles that are created using lithographic techniques. Most are designed to penetrate the stratum corneum and enter into the epidermis without entering the underlying dermis. By doing so, they avoid nerve endings in the dermis, rendering insertion painless (2–6).

Microneedles come in several different designs, including out-of-plane and in-plane microneedles (7). Out-of-plane needles are designed such that the microneedle is perpendicular to the surface (Fig. 47.1). In-plane microneedles are parallel to the surface but are more difficult to place into arrays. Because cosmetic applications have focused on the out-of-plane microneedle, this chapter will review their use in cosmetics. In-depth discussions of in-plane microneedles can be found elsewhere (8).

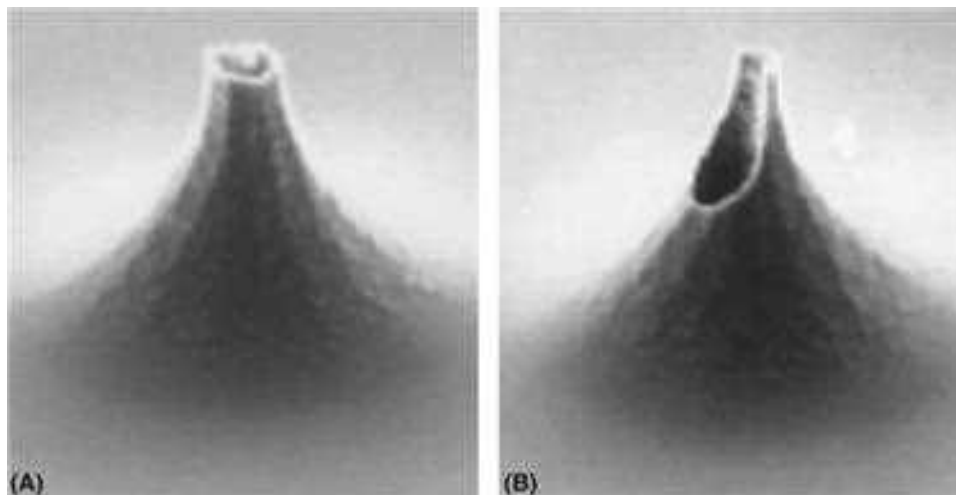
One exception is where in-plane microneedles are used to develop out-of-plane microneedle sheets, which are then converted into a microneedle roller (9). Microneedle rollers have been used for cosmetic applications and will be discussed later. Out-of-plane microneedles are further subdivided into solid and hollow microneedles. Solid microneedles do not have an internal conduit for infusion of drugs and are used to either create physical holes in the stratum corneum or to coat the microneedle such that the drug is delivered from the surface of the microneedle upon insertion. Hollow microneedles have a conduit (Fig. 47.1), and this allows for either bolus or continuous infusion after the microneedle is inserted (Fig. 47.2). Although the first microneedles were fabricated from a silicon surface, the design strategies have evolved to include fabrication from metal (10), titanium (11,12), glass (13–15), polymers (9,14,16–19), and even sugars (3,16,20).

### MICRONEEDLE STRATEGIES FOR DRUG DELIVERY

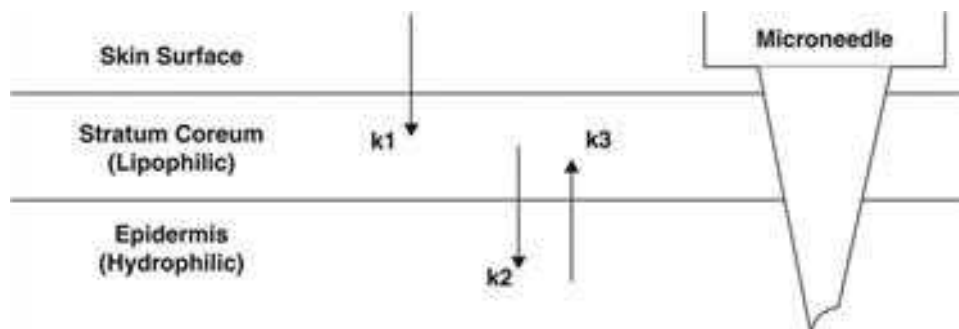
The strategy for drug delivery depends on the design of the microneedle. Because solid microneedles do not have an internal conduit, they cannot be used to infuse drug through the needle. Instead, solid microneedles are used in three different strategies. The first strategy is to create micropores in the stratum through insertion and removal of the microneedle array, and it has been shown that these pores remain open for up to 24 hours before they close (6). Drug solutions can then be applied topically such that they can traverse these transiently open channels to bypass the stratum corneum, and some studies have utilized iontophoresis to accelerate movement through these transiently open channels (21–23). A second strategy is to coat microneedles with a drug prior to insertion. The third strategy is to create dissolving microneedles that dissolve upon insertion to deliver a drug payload. The strategy of coating microneedles or encapsulating a drug payload into a dissolving microneedle is limited to drugs that are stable to undergo the coating or encapsulation process (24). Hollow microneedles have an internal conduit and can be used to infuse drugs as a bolus (25,26) or as a continuous infusion (27) after insertion.

Utilizing these various strategies, microneedles have been employed to deliver vaccines (28–30) or drugs in animals, including insulin (10,14,27,31,32), erythropoietin (16), desmopressin (11), and methotrexate (33). In vivo microneedles investigations in humans have shown their ability to inject nicotinic acid derivatives through hollow silicon out-of-plane microneedles (25,26) and insulin through a hollow glass micropipette tip (34).





**Figure 47.1** Out-of-plane silicon hollow microneedles. (A) Symmetric hollow microneedles are designed so that the opening is right at the point of insertion. (B) Asymmetric microneedles are designed with the opening offset from the point of insertion.



**Figure 47.2** Schematic of hollow out-of-plane microneedle injection. The ability of a substance to move from the skin surface into the stratum corneum is determined by  $k_1$ . The rate of movement from the lipophilic stratum corneum into the more hydrophilic epidermis is determined by the ratio  $k_3/k_2$ . Drug solutions injected by microneedle bypass the transitions indicated by  $k_1$  and  $k_2$ . In the case of lipophilic drugs, some of the drug may partition back into the stratum corneum due to the “effective partition coefficient”  $k_3/k_2$ . Source: From Ref. 25.

## COSMETIC USES

### Solid Microneedles

Several studies have investigated the use of solid microneedles (Table 47.1) in cosmetics. Two microneedle-based devices are available commercially, which include the Dermaroller<sup>®</sup> and the MTS-Roller<sup>™</sup>. Their applications have included the increased penetration of topical hair growth products, photodynamic therapy, and a claim to stimulate collagen reformation.

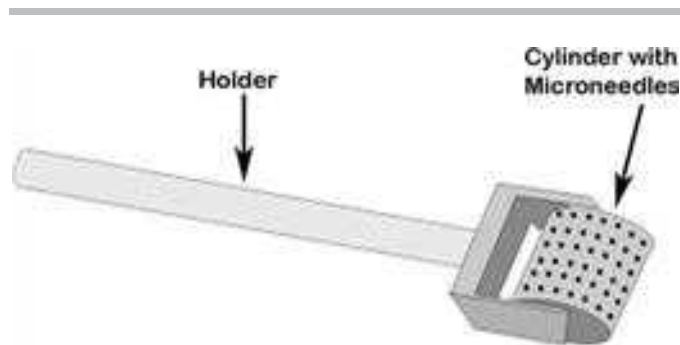
One study evaluated the use of a polymer-based microneedle roller to enhance the topical delivery of L-ascorbic acid for hair growth. In this study, the strategy employed was to create microchannels and then topically apply L-ascorbic acid. They showed that, in mice, the use of microneedle roller could enhance cutaneous permeation by approximately 10-fold and that this enhanced hair growth in mice (35). No human studies have investigated the use of microneedle rollers to facilitate delivery of hair growth molecules.

Photodynamic therapy (PDT) frequently requires the local application of a photosensitive drug in conjunction with incident light to selectively destroy cells, presumably through locally generated singlet oxygen (36). In successful treatment of basal cell carcinomas (BCCs) with topical 5-aminolevulinic acid (5-ALA), patients required four to six hours of topical treatment time, and this was effective for lesions with a depth up to 1 mm (37). In particular, superficial BCC are more amenable to photodynamic therapy than other BCC subtypes that can extend deeper. In an attempt to more efficiently deliver topical photosensitive drugs, silicon microneedle patches were used to create transient microchannels in nude mice and deliver either 5-ALA (38) or meso-tetra (*N*-methyl-4-pyridyl) porphine tetra tosylate, a preformed photosensitizer (39). Both of these studies delivered the photosensitizing drug by placing a transdermal patch over the area that had been transiently perforated with a microneedle patch. Both studies found that

**Table 47.1** Studies of Microneedles Used For Cosmetic Treatments

Device	Material	Type of study	Use	Notes
Out-of-plane solid MN roller (35)	Polymer	In vivo animal study in rats	Topical delivery of L-ascorbic acid through MN created microchannels	10-fold increase in permeation at MN treated sites Faster hair growth in MN treated rats
Out-of-plane solid MN roller (Dermaroller <sup>®</sup> ) (41)	Stainless steel	Ex vivo human skin	Topical delivery of radiolabeled mannitol through MN created microchannels	2- to 10-fold increase in TEWL after MN treatment 30- to 50-fold increase in penetration after MN treatment
Out-of-plane hollow microneedle patch (38,39)	Silicon coated with titanium and platinum	In vivo animal study in nude mice	Topical delivery of 5-ALA and a preformed photosensitizer (TMP)	3-fold decrease in time to reach the concentration of non-MN treated sites 2- to 3-fold increase in concentration of photosensitive drug delivered in MN treated sites

*Abbreviations:* MN, microneedle; TEWL, transepidermal water loss; TMP, meso-tetra (*N*-methyl-4-pyridyl) porphine tetra tosylate; ALA, aminolevulinic acid.



**Figure 47.3** Dermaroller<sup>®</sup> schematic. Stainless steel microneedles are placed in a cylindrical arrangement. *Source:* From Ref. 41.

the photosensitizing drug was delivered in greater quantities, to a greater depth, and in a shorter time in comparison to sites that were not perforated with the microneedle patch. Advantages of microneedle-based therapy would be the use of less photosensitizing drug, less side effect profile, and increased depth of treatment. However, this will require more critical evaluation through clinical studies before the mice studies can be extended to human treatment.

Another commercially available microneedle device sold by Dermaroller S.a.r.l. (Germany) is the Dermaroller (40), which is a hand-held roller with rows of stainless steel, solid out-of-plane microneedles (Fig. 47.3). Two claims made regarding the Dermaroller are that it can be used to enhance transdermal drug delivery and to reorganize underlying collagen in the dermis (40). The first claim for enhancing transdermal drug delivery works on the strategy of creating transient microchannels in the stratum corneum to allow for topical delivery of various drugs, sera, or vitamins necessary for the particular cosmetic treatment. This is supported by a study that evaluated the use of the Dermaroller in human skin *ex vivo* to show that the use of the Dermaroller significantly enhanced transdermal drug penetration (41). Increased penetration was noted with an increase in the microneedle size. The second claim has less evidence as there are no published studies that analyze the underlying dermis after use of the Dermaroller. Interestingly, the Derma-

roller is claimed to be painless, which by definition requires that the microneedles should not penetrate past the epidermis since it is the dermis that contains nerve endings. However, a claim that the microneedles could cause microinjuries to the dermis to stimulate reorganization of the collagen would require penetration into the dermis and would stimulate the pain fibers in the dermis. Clinically, the Dermaroller leads to bleeding at the insertion and treatment sites. This indicates that the microneedles penetrate into the dermis since the epidermis does not contain blood vessels. It is likely that the Dermaroller penetrates into the dermis and causes pain, necessitating the use of anesthetics prior to use. Clinical studies will be necessary to further evaluate the claim of painless reorganization of the dermis.

Another commercially available device sold by Clinical Resolution Laboratories, Inc. is the MTS-Roller, which is another roller composed of an array of microneedles similar to the Dermaroller. The MTS-Roller is used to create transient microchannels in the stratum corneum to deliver two proprietary formulas for wrinkles and for hair loss. However, no clinical studies are publicly reported regarding the use of the MTS-Roller for these indications. The company lists two studies of MTS-Roller for the stimulation of collagen reformation in the dermis and for comparative investigation against intense pulsed light (IPL) as a stimulus for collagen synthesis. Similar to the Dermaroller, the MTS-Roller is claimed to induce collagen reformation through injury to the dermis. Autologous platelet-rich plasma is obtained from the patient and then delivered to the treatment site to induce more collagen synthesis, but there are no published clinical studies to support or refute this claim. The MTS-Roller is claimed to be painless; however, the MTS-Roller likely reaches the dermis. Because the dermis contains nerve endings, a formal clinical study would better elucidate the mechanisms involved in the use of the MTS-Roller.

### Hollow Microneedles

Only a few animal (27,42) and clinical (25,26,34) studies of hollow microneedles have been performed. Currently, there are no commercial cosmetic devices that utilize hollow microneedles. However, microinjection through microneedles offers many exciting opportunities including the injection of Botox<sup>®</sup>, photodynamic therapy, localized stimulation of hair

growth or hair loss, and localized melanin injection. Future research will determine the hollow microneedle's impact in cosmetic therapy. In particular, superficial and painless injections of Botox may be possible in light of the development of topical Botox delivery (43).

### SAFETY OF MICRONEEDLES

One of the initial concerns with microneedles was the biocompatibility of silicon or glass, since there are reports of silicon- and glass-related granulomas (44,45). Most microneedles are developed to only penetrate into the epidermis, and not the dermis. Therefore, any broken pieces of a microneedle will likely be discarded within four weeks, as this is the normal turnover time for the epidermis. In addition, microneedle fabrication is moving toward polymer- and sugar-based synthesis since silicon is expensive when considering mass production for commercialization. The polymers and sugars are biocompatible and many are designed to biodegrade. As microneedle technology continues to move toward biocompatibility, microneedle material-related toxicity will likely become less of a concern.

The stratum corneum is also a formidable barrier against infection. Microneedles physically breach this barrier, raising the possibility for cutaneous infections. Channels created by solid microneedles are open transiently for 24 hours or less (6), and microneedles create a lower bacterial burden than injection with traditional hypodermic needles (46). Transient insertions of solid microneedles likely present decreased infectious risk as compared with the traditional hypodermic needle. However, the use of hollow microneedles for extended infusions may elevate the risk for infection. There are no studies of the infectious risk of long-term infusions with hollow microneedles, and the risk of cutaneous infections will need to be addressed in future studies.

### CONCLUSION

The future of microneedle use in cosmetics is bright. With microneedles, it is now possible to transdermally deliver large peptides and molecules that would not have been possible previously. Because they are typically painless upon insertion, this can greatly increase patient comfort and acceptance. Currently, cosmetics research has focused on solid microneedles, but this will likely broaden to hollow microneedles. Continued collaboration between bioengineers and dermatologists will be critical to the evolution and growth of the microneedle's role in cosmetics.

### REFERENCES

1. Prausnitz MR, Langer R. Transdermal drug delivery. *Nat Biotechnol* 2008; 26(11):1261-1268.
2. Sivamani RK, Stoeber B, Wu GC, et al. Clinical microneedle injection of methyl nicotinate: stratum corneum penetration. *Skin Res Technol* 2005; 11(2):152-156.
3. Miyano T, Tobinaga Y, Kanno T, et al. Sugar micro needles as transdermic drug delivery system. *Biomed Microdevices* 2005; 7(3):185-188.
4. Kaushik S, Hord AH, Denson DD, et al. Lack of pain associated with microfabricated microneedles. *Anesth Analg* 2001; 92(2):502-504.
5. Bal SM, Caussin J, Pavel S, et al. In vivo assessment of safety of microneedle arrays in human skin. *Eur J Pharm Sci* 2008; 35(3):193-202.
6. Haq MI, Smith E, John DN, et al. Clinical administration of microneedles: skin puncture, pain and sensation. *Biomed Microdevices* 2009; 11(1):35-47.
7. Sivamani RK, Liepmann D, Maibach HI. Microneedles and transdermal applications. *Expert Opin Drug Deliv* 2007; 4(1):19-25.
8. Reed ML, Lye WK. Microsystems for drug and gene delivery. *Proc IEEE* 2004; 92(1):56-75.
9. Han M, Hyun D-H, Park H-H, et al. A novel fabrication process for out-of-plane microneedle sheets of biocompatible polymer. *J Micromech Microeng* 2007; 17(6):1184-1191.
10. Davis SP, Martanto W, Allen MG, et al. Hollow metal microneedles for insulin delivery to diabetic rats. *IEEE Trans Biomed Eng* 2005; 52(5):909-915.
11. Cormier M, Johnson B, Ameri M, et al. Transdermal delivery of desmopressin using a coated microneedle array patch system. *J Control Release* 2004; 97(3):503-511.
12. Tsuchiya K, Nakanishi N, Uetsuji Y, et al. Development of blood extraction system for health monitoring system. *Biomed Microdevices* 2005; 7(4):347-353.
13. Lee S, Jeong W, Beebe DJ. Microfluidic valve with cored glass microneedle for microinjection. *Lab Chip* 2003; 3(3):164-167.
14. McAllister DV, Wang PM, Davis SP, et al. Microfabricated needles for transdermal delivery of macromolecules and nanoparticles: fabrication methods and transport studies. *Proc Natl Acad Sci U S A* 2003; 100(24):13755-13760.
15. Wang PM, Cornwell M, Prausnitz MR. Minimally invasive extraction of dermal interstitial fluid for glucose monitoring using microneedles. *Diabetes Technol Ther* 2005; 7(1):131-141.
16. Ito Y, Yoshimitsu J, Shiroyama K, et al. Self-dissolving microneedles for the percutaneous absorption of EPO in mice. *J Drug Target* 2006; 14(5):255-261.
17. Matsuda T, Mizutani M. Liquid acrylate-endcapped biodegradable poly(epsilon-caprolactone-co-trimethylene carbonate). II. Computer-aided stereolithographic microarchitectural surface photoconstructs. *J Biomed Mater Res* 2002; 62(3):395-403.
18. Park JH, Allen MG, Prausnitz MR. Biodegradable polymer microneedles: fabrication, mechanics and transdermal drug delivery. *J Control Release* 2005; 104(1):51-66.
19. Park JH, Allen MG, Prausnitz MR. Polymer microneedles for controlled-release drug delivery. *Pharm Res* 2006; 23(5):1008-1019.
20. Kollis CS, Banga AK. Characterization of solid maltose microneedles and their use for transdermal delivery. *Pharm Res* 2008; 25(1):104-113.
21. Chen H, Zhu H, Zheng J, et al. Iontophoresis-driven penetration of nanovesicles through microneedle-induced skin microchannels for enhancing transdermal delivery of insulin. *J Control Release* 2009; 139(1):63-72.
22. Katikaneni S, Badkar A, Nema S, et al. Molecular charge mediated transport of a 13 kD protein across microporated skin. *Int J Pharm* 2009; 378(1-2):93-100.
23. Wu XM, Todo H, Sugibayashi K. Enhancement of skin permeation of high molecular compounds by a combination of microneedle pretreatment and iontophoresis. *J Control Release* 2007; 118(2):189-195.
24. Gill HS, Prausnitz MR. Coating formulations for microneedles. *Pharm Res* 2007; 24(7):1369-1380.
25. Sivamani RK, Stoeber B, Liepmann D, et al. Microneedle penetration and injection past the stratum corneum in humans. *J Dermatol Treat* 2009; 20(3):156-159.
26. Sivamani RK, Stoeber B, Wu GC, et al. Clinical microneedle injection of methyl nicotinate: stratum corneum penetration. *Skin Res Technol* 2005; 11(2):152-156.
27. Roxhed N, Samel B, Nordquist L, et al. Painless drug delivery through microneedle-based transdermal patches featuring active infusion. *IEEE Trans Biomed Eng* 2008; 55(3):1063-1071.
28. Kim YC, Quan FS, Yoo DG, et al. Improved influenza vaccination in the skin using vaccine coated microneedles. *Vaccine* 2009; 27(49):6932-6938; [Epub September 15, 2009].

29. Zhu Q, Zarnitsyn VG, Ye L, et al. Immunization by vaccine-coated microneedle arrays protects against lethal influenza virus challenge. *Proc Natl Acad Sci U S A* 2009; 106(19):7968–7973.
30. Ding Z, Verbaan FJ, Bivas-Benita M, et al. Microneedle arrays for the transcutaneous immunization of diphtheria and influenza in BALB/c mice. *J Control Release* 2009; 136(1):71–78.
31. Gardeniers H, Luttge R, Berenschot EJW, et al. Silicon micro-machined hollow microneedles for transdermal liquid transport. *J Microelectromech Syst* 2003; 12(6):855–862.
32. Ito Y, Hagiwara E, Saeki A, et al. Feasibility of microneedles for percutaneous absorption of insulin. *Eur J Pharm Sci* 2006; 29(1):82–88.
33. Vemulapalli V, Yang Y, Friden PM, et al. Synergistic effect of iontophoresis and soluble microneedles for transdermal delivery of methotrexate. *J Pharm Pharmacol* 2008; 60(1):27–33.
34. Gupta J, Felner EI, Prausnitz MR. Minimally invasive insulin delivery in subjects with type 1 diabetes using hollow microneedles. *Diabetes Technol Ther* 2009; 11(6):329–337.
35. You SK, Noh YW, Park HH, et al. Effect of applying modes of the polymer microneedle-roller on the permeation of l-ascorbic acid in rats. *J Drug Target* 2010; 18(1):15–20.
36. Kennedy JC, Pottier RH, Pross DC. Photodynamic therapy with endogenous protoporphyrin IX: basic principles and present clinical experience. *J Photochem Photobiol B* 1990; 6(1–2):143–148.
37. Morton CA, MacKie RM, Whitehurst C, et al. Photodynamic therapy for basal cell carcinoma: effect of tumor thickness and duration of photosensitizer application on response. *Arch Dermatol* 1998; 134(2):248–249.
38. Donnelly RF, Morrow DI, McCarron PA, et al. Microneedle-mediated intradermal delivery of 5-aminolevulinic acid: potential for enhanced topical photodynamic therapy. *J Control Release* 2008; 129(3):154–162.
39. Donnelly RF, Morrow DI, McCarron PA, et al. Microneedle arrays permit enhanced intradermal delivery of a preformed photosensitizer. *Photochem Photobiol* 2009; 85(1):195–204.
40. Available at <http://www.dermaroller.de/> [Cited October 14, 2009.]
41. Badran MM, Kuntsche J, Fahr A. Skin penetration enhancement by a microneedle device (Dermaroller) in vitro: dependency on needle size and applied formulation. *Euro J Pharm Sci* 2009; 36(4–5):511–523.
42. Hafeli UO, Mokhtari A, Liepmann D, et al. In vivo evaluation of a microneedle-based miniature syringe for intradermal drug delivery. *Biomed Microdevices* 2009; 11(5):943–950.
43. Glogau RG. Topically applied botulinum toxin type A for the treatment of primary axillary hyperhidrosis: results of a randomized, blinded, vehicle-controlled study. *Dermatol Surg* 2007; 33(1 spec no.):S76–S80.
44. Millard DR Jr., Maisels DO. Silicon granuloma of the skin and subcutaneous tissues. *Am J Surg* 1966; 112(1):119–123.
45. Finley J, Knabb J. Cutaneous silica granuloma. *Plast Reconstr Surg* 1982; 69(2):340–343.
46. Donnelly R, Singh T, Tunney M, et al. Microneedle arrays allow lower microbial penetration than hypodermic needles in vitro. *Pharm Res* 26(11):2513–2522; [Epub September 11, 2009].

# Photodynamic therapy in dermatology

Jacques Savary

Photodynamic therapy (PDT) is a therapeutic that has been used since the beginning of the 20th century to destroy tumorous skin lesions.

- 1903: von Tappeiner describes the first PDT with eosin and sun exposure to treat a carcinoma of inferior lip.
- 1913: Friedrich Metz-Beyer administers porphyrin to himself and becomes photosensitive.
- 1950: The absorption of porphyrin by cancerous cells that become photosensitive is highlighted.
- 1980: The interest for PDT increases but patient's photosensitivity is an obstacle.
- 1993: Publication of the first clinical essay on  $\alpha$ -aminolevulinic acid (ALA) in PDT.
- 1995: Registration of the first ALA-modified patent.

This therapeutic had essentially developed in Northern Europe for the treatment of nonmelanocytic skin cancers. Then, PDT had expanded to other European countries and in Northern America in other indications than the ones dealing with skin carcinologic.

## PRINCIPLE

The basic principle in cancer research lies in the selective destruction of abnormal cells of target tissue by a chemical reaction activated by specific light, while preserving normal skin structures. This reaction results from the fixation of a photosensitizing agent on tumorous cells followed by its activation by a floodlight of a light visible at appropriate wavelength. This activation is followed by a phototoxic effect created by an irreversible oxidation mechanism that destroys tumorous cells.

The mechanism of this photochemical reaction is based on light effects on the photosensitizing molecule (1). To each kind of molecule matches a type of wavelength likely to be absorbed. In the basal state, this photosensitizing molecule presents an energy ground state ( $S^0$ ); under the effects of photons produced by the light, this molecule reaches a superior and unstable level of excitation. At this unstable level, the molecule holds an excess of energy that it quickly loses by three ways: heat liberation, fluorescence emission, and transition to a triplet intermediate stage. Turning back from this triplet stage to the basal stage is slow. It is during the triplet stage that the photosensitizing molecule interacts with cells' organelles; thanks to two mechanisms requiring the presence of oxygen in the targeted tissues:

- Direct mechanism: Production of toxic-free radical. In that case, the photosensitizing is damaged.
- Indirect mechanism: Transfer of energy to the oxygen. It fosters its transition to a singlet state able to oxidize amino acids, nucleic acids, and membranes' cells lipids. This mechanism prevails; in that case, the photosensitizing returns to its basal state likely to be excited by the light anew.

## Effects on Tissues

Cellular damages caused by this oxidative stress essentially affect cellular membranes and organelles of cell (mitochondria, endoplasmic reticulum, plasma membrane). These deteriorations lead to cellular necrosis (2). Histological signs of necrosis (eosinophilic cytoplasm, hyperchromatic nuclei) appear within an hour after the lighting.

This cellular necrosis is associated with apoptosis (3) phenomenon (cellular suicide). Apoptosis signs occur more lately; they can be seen 24 hours after the PDT.

Three "actors" are necessary for PDT:

- A photosensitizing molecule
- A light source
- Oxygen

## Photosensitizing

Several photosensitizing have been used at the beginning of the PDT, part of them were systemic sensitizing. These had no specificity and would lead to residual phototoxicity phenomena of the whole tegument imposing on patients extended outstaying from visible light. Thus, to be easily used in dermatology, the photosensitizing requires specificities:

- To focus on tumorous cell
- Can be activated by a light penetrating into the skin
- To produce a significant amount of cytotoxic substances (free radicals and singlet oxygen)
- Can quickly be eliminated from the skin

The use of topical has been favored in dermatology. Most of them are five ALA drifts. In reality, ALA is not the photosensitizing. It is the precursor of an endogenous photosensitizing that physiologically exists in the skin and notably in keratinocytes: protoporphyrin 9 (Pp9). This porphyrin is an intermediate stage in the heme synthesis chain (Fig. 48.1).

Physiologically, some mechanism can auto regulate this heme synthesis by enzymatic systems, especially the ferrochelatase which transform Pp9 in heme. During an ALA or MAL excess supply these auto regulation mechanisms are overwhelmed and a cellular accumulation occurs.

The accumulation increases in epidermic dysplasia (4,5). The intimate mechanism of this specific accumulation is not clearly solved. Several mechanisms are suspected:

- Intense penetration of the ALA in the epidermic dysplasia thanks to membranous modified transportation phenomena.
- Increase of the porphobilinogen desaminase activity
- Decrease of ferrochelatase activity

Nowadays, two kinds of Pp9 precursors are used in skin PDT: amino levulinic acid ALA (Levulan<sup>®</sup>, Kerastick<sup>®</sup>)

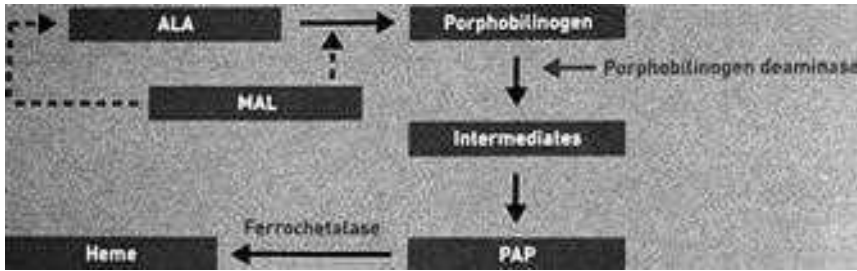


Figure 48.1 Mechanism of action of ALA/MALA.

and its precursor methyl aminolevulinic acid (Metvix<sup>®</sup>, Metvixia<sup>®</sup>).

These two drugs have different properties; the MAL is more lipophilic than the ALA, which awards it a better penetration in the skin. This indication will have an impact on the occlusion time necessary to the product to penetrate: 12 to 18 hours recommended for the ALA (Levulan) and 3 hours for the MAL (Metvix, Metvixia). Moreover, the specificity to the P9 accumulation in keratinocytes in differentiation is more important for the MAL than for the ALA, whereas for a healthy skin, the Pp9 production is much more important after the ALA application than after the MAL one (6). The systemic diffusion of MAL is less important than the one of ALA for the mouse (7). Photoactive porphyrin synthesis detected by fluorescence for the mouse decreases faster after the MAL application than after the ALA one (8). After 24 hours, the fluorescence induced by the MAL has nearly disappeared.

As for the human healthy skin, the fluorescence decrease to  $93.4\% \pm 6.1\%$  30 hours after the cream removal to 20% MAL (9). The depth of MAL penetration measured by the fluorescence intensity is estimated to 2 mm after three hours of occlusion (10).

#### The Light Source

It requires two characteristics: to activate the Pp9 to penetrate sufficiently into the skin to allow the destruction of the targeted lesions.

- The Pp9 activation spectrum consists of several stripes of color (Fig. 48.2)

The maximal absorption stripe for which the Pp9 becomes more energetic lies in the blue at 410 nm, it is the Soret band. Other absorption peaks are of 510, 530, 580, and 630 nm, but they are less energizing (5).

- The light penetration in the skin depends on the wavelength of the light. The longer the length is, the deeper the penetration in the skin is. Thus, the blue penetrates in the stratum corneum, whereas the red penetrates until 2 mm in the skin reaching the dermis hypodermis limits.

Red is preferred for the treatment of cancerous and precancerous lesions regarding its better penetration into the skin. The merest absorption by Pp9 being countered by the use of a more important light energy.

Several sources can be used:

- Sources of high energy
  - LASERS are attractive as they are monochromatic and very energetic. Although the lightening scope size is

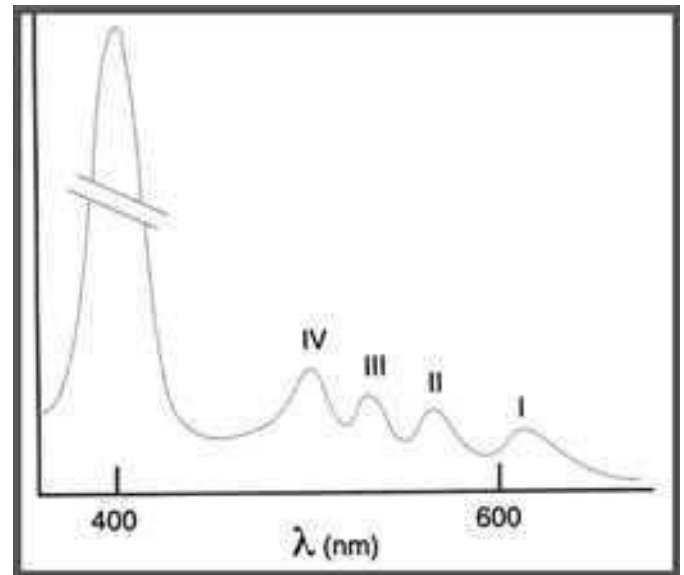


Figure 48.2 Pp 9 activation spectrum.

narrow, the exposure time is very short. As the pulse dye LASER emits at 695 nm, it can be used to activate the Pp9.

- Intense pulsed light (IPL) are very energetic polychromatic light sources. The light emission spectrum depends on the filters used, which allows to choose the inferior limit of the spectrum 550, 560, 580, and 590 nm. As for the LASERS, the exposure time to light is very short (of the order of millisecond kind), but, on the other hand, the lightening scope size is broader.
- Sources of low energy
  - Slides projectors that emit between 570 and 1100 nm have been used by PDT pioneers.
  - Xenon halogens (630 nm) and fluorescence lights emit narrow spectrum and have a good energetic capacity.
  - The light-emitting diodes (LED) are the most frequently used. Their specificity is to emit on a very precise wavelength (variation between 5 to 10 nm). Those small diameter light bulbs are braced to one another to create lamps of which the surface is significant and the form adaptable to the targeted skin area. Their life span is long (10,000 hours) without any energy loss. They are even more attractive that they do not emit infrared and so have no thermal impact.

*Should a high- or low-energy source be chosen?* A short lightening with a very strong energy will brutally activate the porphyrins, which will lead to an intense release of free radicals and of singlet oxygen responsible for the selective destruction of the targeted tissues. Nevertheless, Pp9 synthesis by keratinocytes recurs itself. Some authors advocate for the use of low-energy light sources that allow a long lightening and a continuous activation of porphyrin, which ensure the emission of less brutal and better distributed cytotoxic substances during the lightening (9). Some teams use low-energy sources made of LED (11).

A recent study (12) compared MAL PT with LED (530 nm, 37 J/cm<sup>2</sup>) versus MAL PDT with IPL (610–950 nm 80 J/cm<sup>2</sup>) for the treatment of actinic keratosis, the patient being his own witness. Neither the complete remission rate at three months nor the cosmetic outcomes show a significant difference. On the other hand, the pain is less important with IPL as the lightening time is very short. There is no comparative study dealing with basal cell carcinoma (BCC) and Bowen disease.

*What kind of energy can activate Pp9 and lead to cell destruction?* The amount of necessary energy depends on the Pp9 ALA or MAL precursor, its concentration and the lightening spectrum. The necessary energy had been evaluated for different topical depending on the intensity of the fluorescence visible in Wood light. Thus, the maximal fluence had been determined to obtain the maximal fluorescence. The latter will depend on the emission spectrum: the larger the spectrum is (so outside Pp9 absorption peaks), the more important the fluence will have to be. For instance, for the MAL, the necessary energy is:

- 37 J/cm<sup>2</sup> for a narrow spectrum of 630 nm
- 75 J/cm<sup>2</sup> for a spectrum from 570 to 670 nm
- 85 J/cm<sup>2</sup> for a spectrum of 600 to 750 nm

For LED, halogens, and fluorescent lamps, several indications will have an influence on this fluence (J/cm<sup>2</sup>): the power of the lamp (mW/cm<sup>2</sup>), the distance between the lamp and the skin, and the lightening time.

#### *Oxygen*

It is brought by the blood circulation. Therefore, the elements fostering l'anoxie tissulaire will decrease the efficiency of the technique: cold, vasoconstrictors, sclerosis.

## **PDT INDICATIONS IN DERMATOLOGY**

### **Validated Indications**

They are at the center of studies allowing the registration of products. Today, only the MAL is registered in Europe since 2002 with the following indications:

- Actinic keratosis
- Nodular and superficial BCC when surgery is impossible
- Bowen disease

#### *Actinic Keratosis*

Those precancerous lesions are common on photo-exposed field of scalp, face, hands, and forearms (Fig. 48.3). As they are often many on these areas, they create real fields of possible cancer development (Fig. 48.4). The annual rate of transformation of those actinic keratosis (AK) in squamous cell carcinoma can change from one extreme to another. According to authors, it ranks from 0.25% to 16% (13). All the studies had been done with the MAL, which is the only available product on the market.



**Figure 48.3** Actinic keratosis.



**Figure 48.4** Fields of possible cancer development.

The studies done versus placebo (14) had shown a slightly superior efficiency on complete cure rate (the lesion having completely disappeared).

The comparative studies had been made versus cryotherapy (15,16), which is the reference treatment. Cryotherapy was performed using nitrogen spray and a double-freeze-thaw cycle; the MAL PDT had been done regarding two protocols, either one session or two sessions with a week of interval.

There was no significant difference in the complete response rate at three months and five years between cryotherapy and MAL PDT one session.

The difference between these two techniques lies in the healing result. In studies (15,16), cosmetic outcomes are seen as excellent and good according to more than 90% of the

investigators. In comparison to cryotherapy, cosmetic outcomes are seen as superior for the MAL PDT.

- The MAL PDT efficiency is significantly superior to the one of the placebo: the complete answer rate per patient and per lesion increases under MAL PDT.
- MAL PDT is as efficient as cryotherapy, reference treatment of KA.
- A single session of MAL PDT is efficient on AK lesions and can be renewed if necessary.
- The MAL PDT cosmetic outcomes are considered as superior as the cryotherapy ones.
- In majority, the MAL PDT treatment is considered as very satisfactory by patients who had already been treated and is preferred to former treatments.
- MAL PDT using red light is an appropriate alternative treatment for multiple actinic keratosis on large skin surface (Fig. 48.4).

In its conclusion (13), the International Society for Photodynamic Therapy (IPDT) considers that PDT can be considered as a first intention treatment in the treatment of AK.

#### *Superficial BCC*

BCC are the most frequent tumors occurring in human. The superficial forms are the less aggressive and are considered as low-risk lesions outside the face H zone. Most of the time, these lesions are broad on the above or multiple with a risk of having significant of numerous scars after the surgical cure. PDT is a noninvasive treatment and the quality of its healing result has to be taken into account into the therapeutic decision-making process. A European multicenter study carried out in seven countries had compared the MAL PDT one session to cryotherapy (freezing of at least 20 seconds) in two groups of patients carrying BCC (17,18). The rate of complete answers at 3 months and at 30 months and 5 years per patient and per lesion did not show significant differences between the two groups.

The healing quality assessed by investigators and patients is superior in the MAL PDT group. More patients had an excellent cosmetic outcome with PDT than with cryotherapy.

Those recurrence rates are higher compared to surgery ones. That is the reason why it is better avoiding risky face areas. But PDT offers a best cosmetic outcome than a simple excision surgery (19).

The PDT is a therapeutic alternative for the treatment of CBCs as surgery would be hard to perform because of the localization, the size, the number of lesions (Fig. 48.5), the pathologic state of the patient, or because the healing risk would be disproportionate for a low-risk lesion. The other advantage compared to other nonsurgical techniques such as cryotherapy, electro curettage is that it does not leave any scar, which is satisfying to the patient (Fig. 48.6). Moreover, in case of recurrence, PDT can be repeated and surgery remains possible, as there is no skin modification.

In the superficial CBC treatment:

- The clinical efficiency of the MAL PDT is equivalent to the one of cryotherapy.
- This efficiency is maintained in an equal way after five years of follow-up for both treatments.
- The PDT cosmetic outcome is better than the one of cryotherapy.

In its conclusions, the IPDT (13) considers the PDT as an effective and reliable treatment option for BCCs that offers



**Figure 48.5** Multiple superficial basal cell carcinoma on a patient treated by X-ray therapy for Hodgkin disease.



**Figure 48.6** Cryotherapy scars for basal cell carcinoma.

excellent or good cosmetic outcomes. PDT offers an advantage in the treatment of large, extensive, and multiple lesions.

Photodynamic diagnosis fluorescence diagnosis (PDD) serves as a valuable noninvasive diagnostic and treatment tool. Following topical application of the photosensitizer, a large amount of Pp9 selectively accumulates in the neoplastic cells. When the skin is illuminated with a UVA light source (370–405 nm), the tumoral area shows a distinctive pink to red fluorescence on a background of blue light. This photodynamic diagnosis is useful to detect tumors but is not sufficient to evaluate their margins. Margins evaluation with PDD is better than clinical evaluation but does not correspond with the real margins found with Mohs surgery (20).



### Nodular Basal Cell Carcinoma

The difficulty in the treatment of these lesions lies in the penetration of both the light and the photosensitizer in the superior lesions at 2 mm of thickness. For this kind of tumors, a debulking is performed preliminary to the photosensitizing application. Several studies (21) show three months complete answers rate between 73% and 94% with the MAL PDT.

At five years, recurrence rates reach 14%.

A comparative study between MAL PDT and surgery showed that the three months complete answers rate was not inferior for the PDT (91% versus 98% for surgery). At 60 months, the recurrence rate equal 14% versus 4% for surgery (22).

According to patients, the cosmetic outcomes are superior to the ones of surgery.

In its conclusions, the IPDT believes PDT is an effective and reliable treatment for thin lesions with the advantage of good cosmetic outcome.

### Bowen Disease

This squamous cell carcinoma in situ is frequent on elderly patients. It appears anywhere on the skin but mainly on the lower legs. Approximately 3% transforms in invasive carcinoma. There are often healing problems on leg localization for elderly patients regarding circulatory insufficiency. The treatment of reference is surgery when possible or 5-FU topically (Figs. 48.7 and 48.8).

A European multicenter comparative random study (23) had assessed the MAL PADT in Bowen disease treatment. The assessed therapeutics were MAL PDT or PDT placebo, 5-FU, and cryotherapy.

In Bowen disease treatment:

- MAL PDT efficiency is significantly superior to the one of the placebo.
- The answer rate per patient or per lesion is similar when the patient is treated by MAL PDT, cryotherapy, or 5-FU.
- Those results are maintained 24 months after the treatment; the lesions recurrence rate under MAL PDT is the same as the one under cryotherapy or 5-FU.
- The great majority of investigators believe that the cosmetic outcomes are excellent or good after the treatment by



Figure 48.7 Bowen disease before treatment.



Figure 48.8 Bowen disease after two sessions.

MAL PDT. These results are superior to the ones obtained after cryotherapy.

In its conclusions, the IPDT considers PDT to be an effective treatment for Bowen disease. This therapeutic can be considered as a first-line treatment for Bowen disease. After repeated treatments nonresponders should be considered for surgery.

### Out-of-Label Indications

PDT had been used in multiple indications in studies started with varying protocols. These several studies had been taken up again in a consensual conference by North American authors (24).

#### - Acne

The mechanism of action is not clearly elucidated. There is a clear diminution of *Propionibacterium acnes*, but the target of free radicals and singlet oxygen is essentially the sebaceous gland (25).

Atrophy or even destruction is demonstrated in biopsy after one PDT treatment. Comparison can be made with isotretinoin that induces a cellular apoptosis of sebocytes and reduces the sebum excretion rate. This glandular atrophy is not permanent and seems to be restored with time. But there is a lack of long-term histological data on sebaceous gland atrophy after PDT.

PDT is especially useful for inflammatory acne but side effects are sometimes serious. Observations report varying degrees of pain, erythema, edema, blistering, and acute flare up. This last side effect can be compared to isotretinoin. Optimization of efficacy-tolerance ratio is necessary. Concentration of photosensitizer, time of application, occlusion or not, and fluence parameters are certainly different from those used to treat nonmelanoma skin cancer.

Mavilia et al. report a significant improvement of inflammatory acne.

It appears that the nature of photosensitizer has an impact on efficacy.

The acne indication had benefit from many studies, especially with the ALA PDT and several light sources. The consensual conference conclusions are as follows:

- i. The best indications are inflammatory and cystic acne.
  - ii. The improvement is limited in comedonal acne, except in a study with a pulsed dye LASER.
  - iii. Acneiform flares appear after each treatment. They seem to depend on the photosensitizing concentration, the application time, and the light source. Nevertheless, these therapeutic protocols are not clearly defined yet.
- Photoaging

This indication has also been submitted to several works in Canada and in the United States. Pp9 is prone to store in keratinocytes in multiplication. Therefore, PDT is particularly recommended in severe photodamage: severe elastosis associated with AK, early skin cancer, pigmentary changes, vascular changes (erythema, telangiectasia), and rhytides (26).

Photorejuvenation action of PDT was found after AK treatment and the skin on the treatment area appears younger, without rhytides, smooth with a best trophicity.

This improvement of the appearance of skin corresponds to significant molecular changes in the photodamaged skin. Type I and type III procollagen mRNA significantly increased after treatment with ALA PDT and pulsed dye laser (PDL) versus PDL alone.

Historically, increased proliferation and changes in epidermis thickness were observed.

High-resolution echography shows an increase in skin thickness and a reduction of subepidermal low echogenic band thickness.

Clinically, there is an improvement of signs of photo-damage: mottled pigmentation, fine lines, roughness, and sallowness of the skin. There is no change in deep wrinkles, telangiectasia, and sebaceous gland hypertrophy.

The majority of North American studies deal with PDT with ALA and IPL with various protocols regarding photosensitizing concentration, time of application, and light energy. There is no doubt that the decrease of the concentration and of the application time diminishes side effects but it also implies a very weak synthesis of Pp9, which can damage the technique's efficiency. The use of IPL PDT versus IPL only would reduce the number of IPL sessions to obtain the same result on photoaging signs.

European studies with MAL PDT also confirm the efficiency on photoaging (27).

- PDT and onychomycosis
- Some case reports suggest that PDT may represent an alternative treatment in therapeutic strategy for onychomycosis. The nail plate and the hyperkeratosis nail bed are first removed, and the treatment is repeated between three and six times according to the studies. The MAL PDT protocol is the same as that in oncologic indications: MAL 20% three hours with occlusion, uncoherent red light (630 nm), 37 J/cm<sup>2</sup>. Patients do not report pain during irradiation or after.
- Warts
  - Dyskeratosis: Hailey Hayley; Darier
  - Healing
  - Extramammary Paget.
  - Psoriasis
  - Hair removal
  - Cutaneous leishmaniasis
  - Cutaneous T cell lymphoma
  - Molluscum contagiosum



Figure 48.9 Lesion illumination.

## PDT IN PRACTICE

It is a simple technique; non-operator-dependent that can easily be done at a medical office. The PDT session takes place in three stages:

- Lesion's preparation: soft cleaning with the curette to remove loose scales and crusts, application of the MAL as a cream covering the lesion with a one cm margin at the edge. Cover with an occlusive dressing and then with a totally opaque dressing, especially on exposed areas.
- Keep the cream and the dressing during three hours
- Remove the dressings, wash the remaining cream with a compresses and saline solution, and start the lightening. Parameters of LED lamps are generally already set. Depending on the lamps, it usually lasts between 8 and 10 minutes (Fig. 48.9)

Post-treatment care is simple: the treated zone needs to be protected from light for at least 24 hours, then a dry dressing and application of emollient can be done daily.

Right after, the reactions are pain, erythema, l'edema.

In a second time, the following reactions may happen:

- Squamae
- Crusts
- Suppuration
- Blisters
- Skin ulceration
- Skin pigmentations after sun exposure

## PDT and Pain

- All the patients report an unpleasant burning, stinging, or pricking feeling.
- Around 20% of them report a pain ranking between 7 and 10 (on a pain analogical scale) requiring specific care (28).
- Pain appears from the beginning of the lightening and increases since the first minutes, reaches a plateau, and decreases slowly once the lightening stopped (29).
- The pain origin seems to be neurological as les GABA receptors intervene (30).

- This pain depends on (31):
  - The localization: more intense at the scalp and face than on the rest of the body (32)
  - The kind of tumor: more important for actinic keratosis than for BCC and Bowen disease
  - The lesion's size: the pain increases with the size
  - Fluence rate, pain is reduced with lower fluence rate but time exposure is increased.
- The practitioner has to take the pain into account during the lightening
  - Vocal anesthesia: do not leave the patient alone, talk to reduce his anxiety, modify the pain, and suggest solution to reduce it.
  - Physical means aimed at cooling down the pain are the most efficient: fan, water spray, liquid nitrogen spray. If the pain is too important, it is possible to interrupt the lightening a few minutes, to cool down the skin to start the lightening again (20).
  - Nerved block and local anesthesia without vasoconstrictive agent may be useful.

PDT should be considered as a new therapeutic resource that especially fits numerous AK on large area treatment. Future studies will have to confirm the PDT preventive aim in field cancerization. Regarding Bowen disease and CBCs, PDT represents a solution for broad and multiple lesions when surgery is hard to perform or risky. We can only wish that in a few years indications out of nonmelanoma skin cancer will benefit from studies able to define precise protocols.

## REFERENCES

1. Mordon S. La thérapie photodynamique vasculaire: une nouvelle thérapeutique pour le traitement des angiomes plans. *Ann Dermatol Venereol* 2007; 134:281–286.
2. Noodt BB, Berg K, Stokke T, et al. Apoptosis and necrosis induced with light and 5-aminolevulinic acid derived protoporphyrin IX. *Br J Cancer* 1996; 74:22–29.
3. Nakaseko H, Kobayashi M, Akita Y, et al. Histological changes and involvement of apoptosis after photodynamic therapy for actinic keratosis. *Br J Dermatol* 2003; 148:122–127.
4. Angell-Petersen E, Serensen R, Warloe T, et al. Porphyrin formation in actinic keratosis and basal cell carcinoma after topical application of methyl 5 aminolevulinic acid. *J Invest Dermatol* 2006; 126:265–271.
5. Chamberlain AJ, Kurwa HA. Photodynamic therapy Is it a valuable treatment option for actinic keratosis? *Am J Clin Dermatol* 2003; 4:149–155.
6. Fritsch C, Homey B, Stzhl W, et al. Preferential relative porphyrin enrichment in solar keratoses upon topical application of delta aminolevulinic acid methyl ester. *Photochem Photobiol* 1998; 68:218–221.
7. Sorensen R, Juzenas P, Iani V, et al. Formation of protoporphyrin IX in mouse skin after topical application of 5-aminolevulinic acid and its methyl ester. *SPIE* 1998; 3563:77–81.
8. Peng Q, Moan J, Warloe T, et al. Build-up of esterified aminolevulinic-acid-derivative-induced porphyrin fluorescence in normal mouse skin. *J Photochem Photobiol B Biol* 1996; 34:95–96.
9. Angell-Petersen E, Christensen C, Müller CR, et al. Phototoxic reaction and porphyrin fluorescence in skin after topical application of methyl aminolevulinic acid. *Br J Dermatol* 2007; 156:301–307.
10. Juzeniene A, Juzenas P, Ma L-W, et al. Topical application of 5-aminolevulinic acid, methyl 5-aminolevulinic acid on normal human skin. *Br J Dermatol* 2006; 155:791–799.
11. Moseley H. Update on PDT light sources 7th Euro-PDT Annual Congress Paris, 2007.
12. Babilas P, Knobler R, Hummel S, et al. Variable pulsed light is less painful than light-emitting diodes for topical photodynamic therapy of actinic keratosis: a prospective randomized controlled trial. *Br J Dermatol* 2007; 157:111–117.
13. Braathen LR, Szeimies RM, Basset-Seguín N, et al. and all Guidelines on the use of PDT for nonmelanoma skin cancer: an international consensus. *J Am Acad Dermatol* 2007; 56:125–143.
14. Pariser DM, Lowe NJ, Stewart DM, et al. Photodynamic therapy with topical methyl aminolevulinic acid for actinic keratosis: results of a prospective randomized multicenter trial. *J Am Acad Dermatol* 2003; 48:227–232.
15. Szeimies RM, Karrer S, Radakovic-Fijan S, et al. Photodynamic therapy using topical methyl 5-aminolevulinic acid compared with cryotherapy for actinic keratosis: a prospective, randomized study. *J Am Acad Dermatol* 2002; 47:258–262.
16. Freeman M, Vinciullo C, Francis D, et al. A comparison of photodynamic therapy using topical methyl aminolevulinic acid (Metvix®) with single cycle cryotherapy in patients with actinic keratosis: a prospective, randomized study. *J Dermatol Treat* 2003; 14:99–106.
17. Basset-Seguín N, Ibbotson S, Emtestam L, et al. Topical methyl aminolevulinic acid photodynamic therapy versus cryotherapy for superficial basal cell carcinoma: a five year randomized trial. *J Eur Acad Dermatol Venereol* 2008; 18(5):547–553.
18. Basset-Seguín N. MAL PDT for superficial basal cell carcinoma 7th Euro-PDT Annual congress Paris, 2007.
19. Szeimies RM, Ibbotson S, Murrell DF, et al. A clinical study comparing methyl aminolevulinic acid photodynamic therapy in small superficial basal cell carcinoma (8–20 mm), with a 12 month follow up. *J Eur Acad Dermatol Venereol* 2008; 22(11):1302–1311.
20. Alkalay R, Alkalay J, Maly A, et al. Fluorescence imaging for the demarcation of basal cell carcinoma tumor borders. *J Drugs Dermatol* 2008; 7:1033–1037.
21. Tope WD, Menter A, El-Azhary RA, et al. Comparison of topical methyl aminolevulinic acid photodynamic therapy versus placebo photodynamic therapy in nodular BCC. *J Eur Acad Dermatol Venereol* 2004; 18(suppl 2):413–414.
22. Rhodes LE, de Rie M, Leifsdottir R, et al. Five year follow-up of a randomized, prospective trial of topical methyl aminolevulinic acid vs surgery for nodular basal cell carcinoma. *Arch Dermatol* 2007; 143(9):1131–1136.
23. Morton CA, Horn M, Leman J, et al. A randomized, placebo-controlled, European study comparing MAL-PDT with cryotherapy and 5-fluorouracil in subjects with Bowen's disease. *J Eur Acad Dermatol Venereol* 2004; 18(suppl 2):415.
24. Nestor MS, Gold MH, Kauvar AN, et al. The use of PDT in dermatology: results of a consensus conference. *J Drugs Dermatol* 2006; 5:140–154.
25. Taylor MN, Gonzalez ML. The practicalities of photodynamic therapy in acne vulgaris. *Br J Dermatol* 2009; 160:1140–1148.
26. Nestor MS, Goldbert DJ, Goldman MP, et al. New perspectives on photorejuvenation. *Skin Aging* 2003; 11:68–74.
27. Ruiz-Rodriguez R, Sanz-Sanchez T, Cordoba S. Photodynamic Photorejuvenation. *Dermatol Surg* 2002; 28:742–744.
28. Langan SM. Randomised double blind study, placebo controlled prospective study of topical anesthesia for topical ALA PDT for extensive scalp actinic keratoses. *Br J Dermatol* 2006; 154:146–149.
29. Wiegell SR. Pain associated with PDT using ALA or MAL on tape stripped normal skin. *Arch Dermatol* 2003; 139:1173–1177.
30. Grapengiesser S. Pain caused by PDT of skin cancer. *Clin Exp Dermatol* 2002; 27:493–497.
31. De Haas E. Fractionated illumination significantly improves response of superficial BCC to ALA PDT. *J Invest Dermatol* 2006; 126:2679–2686.
32. Sandberg C. Important factors for pain during PDT for actinic keratosis. *Acta Derm Venereol* 2006; 86:404–408.

# Topical 5-fluorouracil formulations in actinic keratosis treatment

Ravneet R. Kaur, Ali Alikhan, and Howard I. Maibach

## INTRODUCTION

Actinic keratoses (AKs) are precancerous lesions, primarily on sun-exposed areas of the skin, caused by nonionizing radiation (1). Histologically, they appear as dysplastic epidermal keratinocytes (2,3). They occur in approximately 11% to 26% of people in the United States (1). Treatments for AKs include cryosurgery, photodynamic therapy with aminolevulinic acid (ALA), imiquimod, chemical peels, electrosurgery, excision, and dermabrasion (4–8). The most common treatment in the United States is cryosurgery with liquid nitrogen (7,9,10). Although this is effective for a fixed number of lesions, it is difficult if lesions are numerous and widespread. Treatment of a large number of lesions with cryotherapy may be painful or may result in the development of adverse effects (e.g., blisters or pigmentary disturbance), thus limiting the utility of cryotherapy. Topical 5-FU has been a treatment for AK for over 40 years. A number of studies have been conducted to determine the efficacy, safety, and optimal treatment regimens of 5-FU in the management of AKs.

## DISCUSSION OF 5-FU

Topical 5-fluorouracil (5-FU), an antineoplastic antimetabolite, is indicated in the setting of generalized AKs and Bowen's disease (in situ squamous cell carcinoma). Although it is difficult to assess the potential for progression of individual AKs to SCCs, an estimated 40% of SCCs begin as AKs (11,12). Safety and efficacy in other indications have not been established, and diagnosis should be established prior to treatment (13). As a chemotherapeutic agent, fluorouracil destroys AKs by interfering with DNA and RNA synthesis by blocking the methylation reaction of deoxyuridylic acid to thymidylic acid. The subsequent depletion of thymine, particularly in cells that are growing quickly and taking up fluorouracil at a more rapid rate, leads to chemotoxic death of these cells and may be associated with a local inflammatory reaction (6,14).

Fluorouracil is considered pregnancy category X and should not be used in pregnant women. Ideally, it is best to use topical fluorouracil during periods of the year when patients can minimize their sun exposure (e.g., winter) secondary to risk of a phototoxic reaction. Patients should be advised to avoid application of the medicine near the lid margins and mucocutaneous junctions. During the treatment phase, lesions become increasingly erythematous and cause discomfort; small subclinical lesions become visible. This treatment can be temporarily disfiguring, with erythematous ulcerations and crust formation. Once the patient completes the treatment, the lesions usually heal within two weeks of discontinuing treatment. Patients may apply topical fluorouracil preparations for multiple lesions

safely. However, follow-up is required to monitor the progress of treatment and to ensure that the appropriate end point is achieved before ceasing application of the fluorouracil topical agent. Topical fluorouracil has the added benefit of making some subclinical AKs more visible and subsequently clear following its application (15).

Topical 5-FU is available in several concentrations. In the early years of treating AKs, investigators used a variety of concentrations varying from 0.5% to 20% in different vehicles. The most commonly used vehicles were propylene glycol, petrolatum, and a water-washable or water-miscible cream. Today, formulations of topical 5-FU in the United States include 0.5% cream (Carac<sup>TM</sup>), 1% cream and solution (Fluoroplex<sup>TM</sup>), 2% solution (Efudex<sup>TM</sup>) and 5% cream and solution (Efudex), as well as generic formulations (Table 49.1).

There is suggestive evidence that higher concentrations may be more effective, but also more irritating (18). We review studies examining the efficacy and tolerability of the most commonly used formulations: 0.5% and 5% topical 5-FU cream in the setting of AKs of the face and scalp.

## HISTORY OF 5-FU

Topical 5-FU has been a treatment for AKs for over 40 years. 5-FU was first introduced to the medical profession in 1961. When used systemically, it has palliative effects in patients with breast and rectal carcinoma. Falkson and Schultz, who used 5-FU for the treatment of advanced carcinomatosis with prolonged cancer chemotherapy, noted the disappearance of AKs in these same patients (19). Klein first reported the local effects of using cytostatic agents in skin tumors (20), and Dillaha published a report on the use of 5-FU topically (21). Since this time, 5-FU has become one of the most effective modalities available in the treatment of AKs (22). The most commonly used formulations today include 0.5% 5-FU and 5% 5-FU. A micronized form of 0.5% 5-FU (Carac) is the most recent addition to the list of formulations.

## COMPARISON OF TRIALS/METHODS

We reviewed the literature examining efficacy of topical 5-FU preparations for treating AKs of the face and scalp. A Pubmed search (1965 to April 13, 2009) with the terms "topical 5-FU," "5-fluorouracil," and "actinic keratosis" was initially conducted. Inclusion criteria included (i) randomized controlled trials (RCTs); (ii) English language; (iii) studies involving the face, ears, neck, and/or scalp; (iv) no additional medications applied to the face or scalp except mild topical corticosteroids; and (v) only specified drug regimens (0.5% 5-FU once daily for

**Table 49.1** Topical 5-FU Formulations Currently Available in the United States

Concentration (%)	Formulation	Trade name
0.5	Cream	Carac <sup>TM</sup>
1	Cream, solution	Fluoroplex <sup>TM</sup>
2	Solution	Efudex <sup>TM</sup>
2	Solution	Generic
5	Cream, solution	Efudex <sup>TM</sup>
5	Cream, solution	Generic

Information from *Physician's Desk Reference* (16) and *Clinical Dermatology: A Color Guide to Diagnosis and Therapy* (17)

1–4 weeks, 1% 5-FU twice daily for 2–8 weeks, and/or 5% 5-FU twice daily for 2–4 weeks). The primary efficacy measure was complete clearance of all AKs (the proportion of patients at follow up with no clinically visible AKs in the treatment area) at 4 weeks post treatment for studies examining 0.5% 5-FU, 4 weeks and 11 months post-treatment for 1% 5-FU, and 4 to 6 weeks post treatment for 5% 5-FU.

Thirty-two studies were evaluated, and 10 met our study criteria (Table 49.2). Six of these examined 0.5% 5-FU at 4 weeks post treatment (12,18,23–26), while 4 examined 5% 5-FU at 4 to 6 weeks post treatment (18,27–29), and 2 examined 1% 5-FU at 4 weeks and 11 months post treatment (27,30). Complete clearance rates of 0.5% 5-FU ranged from 14.9% (with 1 week of treatment) to 57.8% (with 4 weeks of treatment) and 5% 5-FU complete clearance rates ranged from 43% (with 4 weeks of treatment) to 100% (with 2 weeks of treatment). In two studies, subjects were permitted to apply mild topical corticosteroids, in addition to the topical 5-FU (18,24). As the various studies employed different measurements of tolerability, we were unable to compare this data.

### 0.5% 5-FU

Six studies examined 0.5% 5-FU at four weeks post treatment (12,18,23–26). Complete clearance rates of 0.5% 5-FU ranged from 14.9% (with 1 week of treatment) to 57.8% (with 4 weeks of treatment). Smith et al. examined the use of 0.5% 5-FU versus topical ALA activated by blue light or pulse dye laser. At four weeks post treatment, 54.5% of patients using 0.5% 5-FU had complete clearance of their AK lesions. In several RCTs comparing 0.5% 5-FU to vehicle control cream, 5-FU demonstrated greater efficacy and clearance rates with continued use over time from 14.9% to 26.3% after one week of treatment (12,23–25) to 43% to 57.8% after four weeks of treatment (12,18,25,26).

### 1% 5-FU

1% 5-FU is not a commonly used formulation of 5-FU. However, there are two trials for 1% 5-FU that met the inclusion criteria. Breza et al. performed a split-face controlled comparison study of 1% 5-FU applied twice daily for three weeks versus 1% 5-fluorouracil twice daily followed by 0.4% or 0.5% triamcinolone acetonide cream (TAC) in 10 subjects for 3 weeks and found no detectable difference in the number of new AKs between the combination therapy and fluorouracil alone. Furthermore, after 1 month 4 of the 10 subjects had no AKs on either side of their face. Of note, the combination of 5-FU with TAC decreased the unpleasant irritation caused by fluorouracil. These findings demonstrated that the degree of success with

fluorouracil therapy in AKs is not necessarily related to the degree of inflammation associated with treatment.

Dillaha et al. compared concentrations of 1%, 2.5%, and 5% 5-FU ointment twice daily in a controlled clinical study. The response with the 5% ointment was comparable to some original studies with 20% 5-FU ointment. The results showed that 7/8 (87.5%) patients using 1% 5-FU had complete clearance at 2 to 8 weeks, and 25/26 (96.1%) patients with 5% 5-FU had complete clearance at 2 to 8 weeks. At 4 weeks specifically, 94.4% (17/18) of 5% 5-FU patients achieved clearance. At 11 months post treatment, complete clearance was seen in 0% and 86.4% of the 1% 5-FU and 5% 5-FU groups, respectively; thus the 1% formulation was found to be ineffective for long-term clearance of AKs.

### 5% 5-FU

Four studies examined 5% 5-FU at four to six weeks post treatment (18,27–29). 5% 5-FU complete clearance rates ranged from 43% (with 4 weeks of treatment) to 100% (with 2 weeks of treatment in one study). Two of the trials have been compared with other formulations of 5-FU. Dillaha et al. found 5% 5-FU to be effective with a 94.4% clearance rate. Shuttleworth and Marks had the most impressive results using 5% 5-FU (Efudix<sup>TM</sup>) twice daily for two weeks versus Interferon- $\alpha$  2b injectable. They had a 100% (5/5) clearance rate with no severe adverse reactions. Krawtchenko et al. compared 5% 5-FU twice daily for four weeks to cryosurgery and imiquimod. They found a 96% (23/24) complete clearance rate with 5-FU compared to a 68% (17/25) clearance rate in patients treated with cryosurgery, and an 85% (22/26) clearance rate in patients treated with imiquimod. The histological clearance rates were 32% (8/25) for cryosurgery, 67% (16/24) for 5-FU, and 73% (19/26) for imiquimod. The 12-month follow-up demonstrated high rates of recurrent and new lesions in the 5-FU and cryosurgery arms. The sustained clearance rate of initially cleared individual lesions was 28% (7/25) for cryosurgery and 54% (13/24) for 5-FU. The high rate of recurrence should prompt physicians to offer close follow-up, generally every six months to one year to reassess for recurrent or new lesions.

### SIDE EFFECTS

We were unable to compare data on side effects since the various studies employed different measurements of tolerability. However, it is known that 5-FU can commonly be associated with pain, erythema, inflammation, erosions, and contact dermatitis. Possible adverse reactions to topical 5-FU include (from most common to least common): application site reactions, conjunctivitis, rash, dry skin, allergic reaction, facial edema, hyperesthesia, skin discoloration vesiculobullous rash, and cheilitis (24). To minimize adverse reactions, patients should avoid sun exposure during the treatment period. Of the more common side effects, facial irritation was reported a side effect after four weeks of treatment with topical 0.5% 5-FU in 78% to 96% of patients (12,25). Conversely, Smith et al. reported erythema as the most common and pronounced effect (26). Although both 0.5% 5-FU and 5% 5-FU were found to have comparable degrees of irritation as rated by the investigator in a split-face trial, patients preferred the 0.5% cream, which was rated as more tolerable, convenient, and easier to apply (13,18).

The symptoms of severe application site reactions include erythema, edema, dryness, pain, erosion, burning, and pruritus

**Table 49.2** Clinical Studies Examining 0.5%, 1%, and 5% 5-FU

Authors	Treatment comparison	Complete clearance results 4–6 wk post treatment	Adverse effects
Smith et al., 2003 (24)	Randomized trial evaluating 0.5% 5-FU (Carac™) once or twice daily for 4 wk vs. application of ALA for 1 hr followed by activation with blue light or pulsed dye laser (PDT) in 36 subjects	6/11 (54.5%)	Erythema was the most common and pronounced effect; significant crusting and erosions were seen only in the 5-FU group
Loven et al., 2002 (16)	Single-blind, split-face randomized trial evaluating 0.5% 5-FU daily vs. 5% 5-FU cream twice daily for 4 wk in 21 subjects	Approximately 43% of subjects in both 0.5% and 5% 5-FU groups	Fewer patients treated with the 0.5% cream reported symptoms of facial irritation; the 0.5% was more tolerable, more convenient, and easier to apply
Weiss et al., 2002 (12)	Randomized, double-blind, multicenter, parallel-group trial examining 0.5% fluorouracil (Carac) vs. vehicle cream once daily for 1, 2, or 4 wk in a total of 177 subjects	10/38 (26.3%) subjects in the 1-wk treatment group 8/41 (19.5%) in the 2-wk treatment group 19/40 (47.5%) in the 4-wk treatment group	Most patients experienced mild to moderate facial irritation; 31 patients (78%) experienced facial irritation with 4 wks of treatment
Jorizzo et al., 2002 (23)	Randomized, double-blind, vehicle-controlled, parallel-group multicenter phase III trial examining 0.5% fluorouracil (Carac) once daily for 1, 2, or 4 wks vs. vehicle control in 207 subjects	7/47 (14.9%) subjects in the 1-wk treatment group 17/46 (37%) in the 2-wk treatment group 26/45 (57.8%) subjects in the 4-wk treatment group	Adverse events limited to facial irritation that resolved quickly after treatment; facial irritation seen in 96% of patients treated for 4 wk
Jorizzo et al., 2004 (21)	Prospective, multicenter, randomized, double-blind, vehicle-controlled trial comparing once daily application of 0.5% fluorouracil (Carac) to vehicle cream once daily for 7 days in 144 subjects	16.7% of patients	Eye irritation occurred equally in vehicle and treatment groups; application site reactions were reported in 13 patients (18%) in the treatment group and 3 patients (4%) in the vehicle group; no patient discontinuations were due to adverse events
Jorizzo et al., 2006 (22)	Prospective, randomized, double-blind, vehicle-controlled study, 0.5% 5-FU (Carac) once daily pretreatment was compared to vehicle cream once daily for 7 days prior to cryosurgery in 144 patients	13/72 (18.1%) after 1 wk of treatment	Rash, erythema, pain, and burning were more common in the 5-FU group; conjunctivitis was a common event in both groups; edema, dryness, erosion, and pruritus were not significantly different between treatment groups; no serious adverse events were related to treatment
Dillaha et al., 1965 (25)	Controlled clinical study comparing 1% 5-FU ointment twice daily for 4 wk vs. 5% 5-FU ointment twice daily for 4 wk in 17 subjects	17/18 patients (94.4%)—5% 5-FU 7/8 patients (87.5%)—1% 5-FU completed clearance at 2–8 wk.	After 7 to 14 days of treatment, inflammation increased and erosions formed at sites of AKs; no one developed eye irritation and a lower lip erosion occurred in 1 patient
Shuttleworth and Marks, 1989 (27)	Study comparing 5% 5-FU cream twice daily for 2 wk (Efudix™) vs. interferon- $\alpha$ 2b injectable in 20 subjects	5/5 patients (100%)	No adverse reactions occurred; those in the 5-FU group reported minor redness and scaling during the treatment period, with negligible discomfort
Krawtchenko et al., 2007 (26)	Randomized controlled trial comparing 5% 5-FU ointment (Efudix) twice daily for 4 wk vs. cryosurgery vs. 5% imiquimod in 75 subjects	23/24 patients (96%)	Irregular pigmentation and hypopigmentation less frequent in the imiquimod group than in the 5-FU or cryosurgery group; mild atrophy observed in most patients without significant differences between groups; no serious adverse events in the treatment area
Breza et al., 1976 (28)	A split-face controlled comparison trial comparing 1% 5-FU twice daily for 3 wk vs. 1% 5-FU twice daily followed by 0.4–0.5% triaminolone acetonide cream (TAC) twice daily for 3 wk in 10 patients	4/10 patients (40%)	The inflammation was noticeably suppressed in subjects treated with 5-FU in combination with 0.4% or 0.5% TAC. Six of 10 experienced less burning and 7 of 10 experienced less crusting and discomfort on the side with less inflammation. Two of the 10 subjects developed labial fold inflammation, which occurred only on the control side in both.

and the symptoms of eye irritation are burning, sensitivity, itching, stinging, and watering (24). When compared to other treatment modalities such as ALA with photodynamic therapy, significant crusting and erosions were seen only in the 5-FU group (26). In a study by Weiss et al., 35% of patients experienced facial edema and 29% experienced erosions when using 0.5% 5-FU (Carac) (12). In the split-face study by Loven et al. (previously discussed), there were no statistically significant differences in the incidence of erosion, dryness, burning, pruritus, pain, edema, or other signs and symptoms between the two 5-FU formulations (18). However, a lower cumulative proportion of patients reported these symptoms in association with the 0.5% cream compared with the 5% cream, suggesting an increased in the tolerability of 0.5% 5-FU (Carac). Some of the expected side effects of fluorouracil may possibly be avoided with the use of the 0.5% formulation.

Adverse effects aside, patients may continue applying the drug unless it becomes intolerable to do so. Methods used to “calm” the skin after or during treatment with topical 5-FU include topical steroids, dilute acetic acid soaks (26), cool compresses, and emollients (e.g., white Vaseline) to cracked or sore areas. In two studies, subjects were permitted to apply mild topical corticosteroids during 5-FU treatment, which were added to increase tolerability of the 5-FU and lessen side effects (18,24). Breza et al. demonstrated that use of TAC in conjunction with fluorouracil is a way to lessen the adverse effects of fluorouracil (30). In this split-face study, subjects applied 5-FU alone to one side of their face and 5-FU and TAC to the opposite side of their face—subjects preferred the side with 5-FU and TAC. Six of 10 experienced less burning and 7 of 10 experienced less crusting, inflammation, and discomfort on the combination side.

### CURRENT LIMITATIONS IN KNOWLEDGE

Lesion counting and clearance rate measurement are two factors that have yet to be perfected. AKs fall on a continuous spectrum ranging from sun-damaged skin to squamous cell carcinoma in situ, making them difficult to distinguish. Weinstein et al. found significant differences in AK lesion counting even between experienced dermatologists, suggesting unreliability in counting (31). In the setting of AKs, a large confluent lesion may be counted as one lesion initially and then as multiple lesions on subsequent visits. Furthermore, studies differ in methods used to count lesions—lesions from different “zones” of the face may be counted and summed or lesions from the whole face may be counted and summed. More precise zone division with stereotaxis or well-defined counting templates could increase accuracy of these measurements. Another issue that makes lesion counting difficult is the enhancement of subclinical lesions occurring after application of topical 5-FU—lesions may be missed if counts are done prior to initial application of 5-FU (26). Additionally, the fact that 5-FU always produces side effects, no placebo-controlled study is truly double blind. Though there is no way to control for this, it is important to recognize.

### CONCLUSION

Though results from various trials suggest the superior efficacy of 5% 5-FU to 0.5% 5-FU and 1% 5-FU, high-powered clinical trials comparing treatments are lacking. This is important for two reasons: efficacy and tolerability. In the only split-face study, comparing both formulations, both treatments produced

equivalent rates (43%) of complete clearance (18). In the same study, higher rates of irritation, erosion, dryness, burning, pruritus, pain, and edema were seen with 5% 5-FU. This is not surprising given that 5% 5-FU has a fourfold greater systemic absorption (evaluated via plasma and urine fluorouracil concentrations after topical administration) than 0.5% 5-FU (32,33). The 0.5% formulations had more targeted delivery (greater retention of drug in the skin) and less potential for systemic toxicity. The aforementioned split-face study also employed a twice daily regimen with 5% 5-FU, but only a once daily regimen with 0.5% 5-FU—increased application frequency may be another explanation for decreased tolerability of 5% 5-FU. However, as this is the only study comparing both formulations, these results must be evaluated with caution—more studies are needed to accurately demonstrate a difference in efficacy or tolerability profile.

5-FU may also be given in combination with other treatment modalities for AKs. Some combinations are more effective than others. Pretreatment with 0.025% tretinoin cream nightly for two weeks prior to twice daily 5% 5-FU treatment for three weeks only resulted in complete clearance in 1 of 15 patients (6.7%) (34). On the other hand, Jorizzo et al. found that pretreatment with 0.5% 5-FU daily for seven days with a follow-up visit four weeks later for cryotherapy to remaining AKs resulted in significantly fewer lesions than cryotherapy alone at six months post treatment (23). Additionally, concurrent treatment with mild topical corticosteroids (i.e., 2.5% hydrocortisone cream) may be beneficial in improving tolerability without compromising efficacy (18,23). Concurrent application of 0.5% triamcinolone with 1% 5-FU suppresses inflammation, resulting in fewer 5-FU-related side effects without a compromise in efficacy (30). Better comparative studies, not only between 5-FU formulations but also between 5-FU and other treatments, will assist in the development of a treatment algorithm for first-, second-, and third-line therapies for AKs (35).

Taken together, the dose-response relationship recorded here provides inadequate information to permit a rational conclusion—other than stating that the relationship remains subjective. Nevertheless, there does appear to be some evidence of a dose-response relationship based on a comparison between efficacy rates across trials. A first priority for future research consists of the development of an accurate and reproducible lesion count. This may be accomplished using chemical staining techniques—fluorescent or otherwise—that would be readily visible for counting purposes, perhaps binding to abnormal lipids and/or proteins in disordered AK stratum corneum, but absent in normal stratum corneum.

### REFERENCES

1. Salasche SJ. Epidemiology of actinic keratoses and squamous cell carcinoma. *J Am Acad Dermatol* 2000; 42:4-7.
2. Heaphy MR Jr., Ackerman AB. The nature of solar keratosis: a critical review in historical perspective. *J Am Acad Dermatol* 2000; 43:138-150.
3. Rowert-Huber J, Patel MJ, Forschner T, et al. Actinic keratosis is an early in situ squamous cell carcinoma: a proposal for reclassification. *Br J Dermatol* 2007; 156(suppl 3):8-12.
4. Lawrence N. New and emerging treatments for photoaging. *Dermatol Clin* 2000; 18:99-112.
5. Dinehart SM. The treatment of actinic keratoses. *J Am Acad Dermatol* 2000; 42:25-28.
6. Gupta AK, Davey V, McPhail H. Evaluation of the effectiveness of imiquimod and 5-fluorouracil for the treatment of actinic

- keratosis: critical review and meta-analysis of efficacy studies. *J Cutan Med Surg* 2005; 9:209–214.
7. Lubritz RR, Smolewski SA. Cryosurgery cure rate of actinic keratoses. *J Am Acad Dermatol* 1982; 7:631–632.
  8. Witheiler DD, Lawrence N, Cox SE, et al. Long-term efficacy and safety of Jessner's solution and 35% trichloroacetic acid vs 5% fluorouracil in the treatment of widespread facial actinic keratoses. *Dermatol Surg* 1997; 23:191–196.
  9. Drake LA, Ceilley RI, Cornelison RL, et al. Guidelines of care for actinic keratoses. Committee on Guidelines of Care. *J Am Acad Dermatol* 1995; 32:95–98.
  10. Feldman SR, Fleischer AB Jr., Williford PM, et al. Destructive procedures are the standard of care for treatment of actinic keratoses. *J Am Acad Dermatol* 1999; 40:43–47.
  11. Dinehart SM, Nelson-Adesokan P, Cockerell C, et al. Metastatic cutaneous squamous cell carcinoma derived from actinic keratosis. *Cancer* 1997; 79:920–923.
  12. Weiss J, Menter A, Hevia O, et al. Effective treatment of actinic keratosis with 0.5% fluorouracil cream for 1, 2, or 4 weeks. *Cutis* 2002; 70:22–29.
  13. Williams HC. Actinic keratoses and Bowen's disease In: Williams HC, ed. Evidence Based Dermatology. 2nd ed. Malden, MA: Blackwell Publishing, 2008:301–302.
  14. Eaglstein WH, Weinstein GD, Frost P. Fluorouracil: mechanism of action in human skin and actinic keratoses. I. Effect on DNA synthesis in vivo. *Arch Dermatol* 1970; 101:132–139.
  15. Gupta AK. The management of actinic keratoses in the United States with topical fluorouracil: a pharmaco-economic evaluation. *Cutis* 2002; 70:30–36.
  16. PDR guide to drug interactions, side effects, and indications. Montvale, NJ: Thomson PDR, 2006:5.
  17. Habif TP. Clinical Dermatology: A Color Guide to Diagnosis and Therapy. Philadelphia: Mosby, 2004.
  18. Loven K, Stein L, Furst K, et al. Evaluation of the efficacy and tolerability of 0.5% fluorouracil cream and 5% fluorouracil cream applied to each side of the face in patients with actinic keratosis. *Clin Ther* 2002; 24:990–1000.
  19. Falkson G, Schulz EJ. Skin changes in patients treated with 5-fluorouracil. *Br J Dermatol* 1962; 74:229–236.
  20. Klein E, Helm F, Milgrom H, et al. Tumors of the skin. II. Keratoacanthoma; local effect of 5-fluorouracil. *Skin (Los Angeles)* 1962; 1:153–156.
  21. Dillaha CJ, Jansen GT, Honeycutt WM, et al. Selective cytotoxic effect of topical 5-Fluorouracil. *Arch Dermatol* 1963; 88:247–256.
  22. Simmonds WL. Management of actinic keratoses with topical 5-fluorouracil. *Cutis* 1976; 18:298–300.
  23. Jorizzo J, Weiss J, Furst K, et al. Effect of a 1-week treatment with 0.5% topical fluorouracil on occurrence of actinic keratosis after cryosurgery: a randomized, vehicle-controlled clinical trial. *Arch Dermatol* 2004; 140:813–816.
  24. Jorizzo J, Weiss J, Vamvakias G. One-week treatment with 0.5% fluorouracil cream prior to cryosurgery in patients with actinic keratoses: a double-blind, vehicle-controlled, long-term study. *J Drugs Dermatol* 2006; 5:133–139.
  25. Jorizzo J, Stewart D, Bucko A, et al. Randomized trial evaluating a new 0.5% fluorouracil formulation demonstrates efficacy after 1-, 2-, or 4-week treatment in patients with actinic keratosis. *Cutis* 2002; 70:335–339.
  26. Smith S, Piacquadio D, Morhenn V, et al. Short incubation PDT versus 5-FU in treating actinic keratoses. *J Drugs Dermatol* 2003; 2:629–635.
  27. Dillaha CJ, Jansen GT, Honeycutt WM, et al. Further studies with topical 5-fluorouracil. *Arch Dermatol* 1965; 92:410–417.
  28. Krawtchenko N, Roewert-Huber J, Ulrich M, et al. A randomised study of topical 5% imiquimod vs. topical 5-fluorouracil vs. cryosurgery in immunocompetent patients with actinic keratoses: a comparison of clinical and histological outcomes including 1-year follow-up. *Br J Dermatol* 2007; 157(suppl 2):34–40.
  29. Shuttleworth D, Marks R. A comparison of the effects of intralesional interferon alpha-2b and topical 5% 5-fluorouracil cream in the treatment of solar keratoses and Bowen's disease. *J Dermatol Treat* 1989; 1:65–68.
  30. Breza T, Taylor R, Eaglstein WH. Noninflammatory destruction of actinic keratoses by fluorouracil. *Arch Dermatol* 1976; 112:1256–1258.
  31. Weinstock MA, Bingham SF, Cole GW, et al. Reliability of counting actinic keratoses before and after brief consensus discussion: the VA topical tretinoin chemoprevention (VATTC) trial. *Arch Dermatol* 2001; 137:1055–1058.
  32. Levy S, Furst K, Chern W. A comparison of the skin permeation of three topical 0.5% fluorouracil formulations with that of a 5% formulation. *Clin Ther* 2001; 23:901–907.
  33. Levy S, Furst K, Chern W. A pharmacokinetic evaluation of 0.5% and 5% fluorouracil topical cream in patients with actinic keratosis. *Clin Ther* 2001; 23:908–920.
  34. Lawrence N, Cox SE, Cockerell CJ, et al. A comparison of the efficacy and safety of Jessner's solution and 35% trichloroacetic acid vs 5% fluorouracil in the treatment of widespread facial actinic keratoses. *Arch Dermatol* 1995; 131:176–181.
  35. Ostertag JU, Quaedvlieg PJ, van der Geer S, et al. A clinical comparison and long-term follow-up of topical 5-fluorouracil versus laser resurfacing in the treatment of widespread actinic keratoses. *Lasers Surg Med* 2006; 38:731–739.



## Cosmetic cryosurgery

Rodney D. Sinclair and Poorna Weerasinghe

### INTRODUCTION

Most dermatologists and dermatologic surgeons limit themselves to warts and keratoses. Some also treat skin cancers. Many are unaware of the diverse range of conditions, pathologic and cosmetic, amenable to treatment with liquid nitrogen. Cryosurgical treatments, when applied correctly to appropriately selected patients, produce excellent cosmetic results, which justifies a description of these techniques in a cosmetic dermatology text.

As liquid nitrogen is freely available and cheap, and can be used without local anesthetic, it is often thought of as "low-tech" and unable to compete with the newest lasers. On the contrary, cryosurgery is the equal of high-tech alternatives for therapeutic efficacy and aesthetic outcome for a wide range of conditions. Despite these advantages, cryosurgery tends to be underutilized.

Cryosurgery developed as a dermatological treatment modality about a century ago, with the first cryogens being liquid air and compressed carbon dioxide snow (1). Liquid nitrogen (boiling point  $-196^{\circ}\text{C}$ ) became available during the 1940 and is now the most commonly used cryogen in Dermatology. Other available cryogens include carbon dioxide (boiling point  $-79^{\circ}\text{C}$ ), nitrous oxide ( $-90^{\circ}\text{C}$ ), and fluorocarbon liquids ( $-60^{\circ}\text{C}$ ). The article focuses on the potential uses of liquid nitrogen.

The following is a description of the specific cryosurgical techniques for treatment of an array of lesions seen by the cosmetic and dermatologic surgeon and describes the steps to be taken to achieve good cosmetic results.

### TECHNIQUE AND TERMINOLOGY

Various methods have been devised in the use of cryotherapy of lesions.

1. Open spray freeze technique
2. The applicator technique
3. The cryoprobe method
4. The thermocoupler method

#### The Timed Spot Freeze Technique

The spot freeze technique involves the use of a liquid nitrogen spray gun (Brymill Cryac Gun, Owen Galderma, Fort Worth, Texas, U.S.) that, through an appropriate nozzle, emits an open spray of liquid nitrogen (Fig. 50.1). In general, the nozzle size is chosen according to the size of the lesion; however a "D nozzle" will be suitable for most benign lesions. The flask should be two-thirds full to ensure an even flow of cryogen. Overfilling the flask can lead to the valve icing over. The nozzle is held 1 cm from the skin surface and the center of the lesion is sprayed until an ice ball forms that encompasses the lesion and the desired margin. Pretreatment, the "designated ice field,"

may need to be marked out with a suitable pen, as freezing blurs lesion margins.

Once the ice field reaches the desired size, freezing is stopped temporarily to allow palpation of the ice ball to ensure that the lesion is entirely frozen. Once satisfied of adequate ice formation, the spray of liquid nitrogen may recommence and continue for the appropriate treatment time. During this time, the ice field size should remain constant, with the spray of liquid nitrogen adjusted with the trigger on the spray gun appropriately. If more than one freeze-thaw cycle is needed, then complete thawing should occur before the next cycle. This can be assessed by palpation between the finger and thumb again for the presence of an ice ball as well as waiting for the disappearance of the frozen-white surface appearance.

Lesions greater than 2 cm in diameter are generally best divided into overlapping treatment fields to ensure that the timed spot freeze technique adequately treats all parts of a large lesion (Fig. 50.2). Using only one treatment field may not adequately freeze the deep margins at the periphery of a large lesion.

For the purpose of record keeping treatment; for example, a myxoid cyst may be notated as such:

*Myxoid Cyst, LN<sub>2</sub> (OS), 30 Seconds, 2 FTC, 1 Field*

The record shows that a myxoid cyst was treated with liquid nitrogen (LN<sub>2</sub>) using the open spray timed spot freeze technique (OS), for two freeze-thaw cycles (FTC) of 30 seconds duration each. A single treatment field was required.

The open spray technique is extremely versatile and can be used for most easily accessible lesions. Variations do exist: the paint brush method involves spraying starting from one side of the lesion and moving up and down across the lesion, and the spiral method, where treatment starts in the center of the lesion and moves outward in ever-increasing circles (2). These two techniques are particularly useful for larger lesions and when a light, superficial freeze is desired.

Hyperpigmentation may complicate the treatment of some lesions. Hyperpigmentation is particularly common in people with Fitzpatrick type 3 and 4 skin. Although usually temporary, it may take three to four months to resolve. In general before embarking on this treatment in people with darker complexions, a small test should be performed first.

Hypopigmentation is generally only seen after large doses of liquid nitrogen are applied to the skin, for example, in the treatment of skin cancer. In very fair people, this may go unnoticed. For patients with an olive complexion, to prevent a sharp demarcation between the hypopigmented treated area and surrounding normal pigmentation, "feathering" may be performed. This involves spraying the border of the ice field to ice formation to produce mild hypopigmentation that reduces the contrast with untreated skin. A better cosmetic outcome



**Figure 50.1** Liquid nitrogen cryosurgery equipment. Two standard machines together with pedestal containing a variety of sprays, spray needles, and probes.



**Figure 50.2** Bowen's disease: showing method of freezing successive 2-cm overlapping circles to ensure uniformity of treatment of the whole lesion.

may be achieved when treating lesions within a single cosmetic unit by light spraying the entire cosmetic unit. Because any depigmentation so produced will be permanent, it is better to proceed cautiously when deliberately lightening the skin.

### Cotton-Tipped Dipstick

The dipstick technique involves dipping a cotton wool bud into a cup containing liquid nitrogen and firmly applying the bud to the lesion until a narrow halo of ice forms around the bud. This method is most effective with a cotton bud slightly smaller than the lesion to be treated and the cotton bud is home-made using loosely wrapped cotton wool around the wooden orange (or satay) stick. This holds more liquid nitrogen than prefabricated cotton buds.

Pressure applied to the skin facilitates lower temperatures as a wider area comes into contact. The pressure can also be used to empty vascular lesions leading to a greater fall in temperature.

As adenovirus is capable of survival within liquid nitrogen and other viruses may potentially survive and cross-contaminate one's store of nitrogen (3), redipping is not recommended. Decanting a small amount of liquid nitrogen into a separate new disposable container for each patient treatment is preferred. Dipping a cotton bud into the flask of a spray unit leaves behind cotton fibers that will eventually block the nozzle and lead to uneven flow of cryogen.

### Cryoprobe

Various types of cryoprobes are available; the choice of probe depends on the type and site of the lesion (4). Cryoprobes may be attached to the liquid nitrogen spray guns and are cooled by the stream of nitrogen. The probe is applied directly to the lesion. A thin layer of Vaseline or similar gel may be used on the tip of the probe to facilitate contact with the lesion and release of the probe on thawing. As cooling occurs through conduction of heat from the skin, comparatively longer periods of freezing are required with this technique. Once the ice forms, the probe and lesion is gently retracted to prevent further injury to the surrounding tissues. Direct pressure on a vascular lesion can also be used to empty the lesion and produce a greater fall in temperature, but the amount of pressure will influence the depth of freeze and lateral spread.

### Thermocouple Device

To treat malignant lesions, a temperature probe coupled to a digital thermometer that can read 10 to 75°C can be used. Local anesthetic is injected in to the lesion, and a temperature probe is inserted into the estimated depth of the lesion. Usually a metal or styrene cone is used to concentrate the freeze. The liquid nitrogen is sprayed into the cone until the desired temperature is reached, usually  $-50$  to  $-60^{\circ}\text{C}$ . The process can be repeated until the desired destruction is achieved.

### Mechanism of Action

The mechanism of lesion destruction is similar for all cryogenes and can be divided into four phases:

1. Heat transfer
2. Cell injury
3. Vascular stasis and occlusion
4. Inflammation

### Heat Transfer

The rapid freezing of skin lesions depends on a quick transfer of heat from the skin to a heat sink, for example, liquid nitrogen. The rate of heat transfer is dependent on the temperature difference between the two, in this case 36 to  $-196^{\circ}\text{C}$ .

## Tissue Injury

On application of the cryogen, the initial event is extracellular ice formation. This commences at  $-10$  to  $15^{\circ}\text{C}$ . The transformation of water into ice leads to loss of water from the extracellular compartment. This concentrates the extra cellular solutes and sets up an osmotic gradient across the cellular membranes. The movement of water across membranes is exacerbated by mechanical compression from extracellular ice crystals that damages the cell membrane. The movement of water out of the cell leads to an intracellular concentration of solutes. This damage is mostly reversible.

Irreversible damage is due to intracellular ice formation and is dependent on the rate of cooling and the minimum temperature achieved. The faster the cooling and the lower the temperature, the greater the intracellular ice formation. Ice crystals do not form until temperature  $-5$  to  $-10^{\circ}\text{C}$ . The ice damages organelles (mitochondria and endoplasmic reticulum) and further concentrates electrolytes intracellularly. The rate of thawing also influences the degree of damage, with long thaw times being associated with greater damage due to the accumulation of intracellular electrolytes. Rapid freezing and slow thaw maximize tissue damage to epithelial cells and is most suitable for the treatment for malignancies. In addition, repeat FTCs produce more tissue injury than a single freeze and thaw.

The minimum temperature needed for destruction is cell specific. Cryosurgery causes selective destruction of different cell or tissue types, depending on the temperature reached. The collagen-containing connective tissue types are more resistant to cryodamage than the epidermal cell types, especially melanocytes and deeper epidermal cell layers. Mild freezing causes dermoepidermal separation. Keratinocyte destruction requires a minimum temperature of at least  $-30$  to  $-40^{\circ}\text{C}$ , while melanocytes are much more sensitive, dying at  $-4$  to  $-7^{\circ}\text{C}$ . This fact is the reason for the resulting hypopigmentation following cryotherapy on darker skin individuals. Repigmentation often occurs with migration of melanocytes from the edge of the frozen zone or from undamaged melanocytes within hair follicles. Fibroblasts produce less collagen after a rapid thaw. Therefore, a rapid thaw may be more suitable for the treatment of keloids or benign lesions in areas prone to scarring.

## Vascular Stasis and Occlusion

Cold temperatures lead to vasoconstriction and endothelial damage. At  $-15^{\circ}\text{C}$ , endothelium is damaged and platelet aggregation, along with microthrombus formation, leads to ischemic necrosis of the treated tissue in succeeding hours. A reflex

hyperemia lasting minutes to hours also occurs, appearing as a purplish discoloration at the edge of the defrosting lesion.

## Inflammation

Over the next 24 hours, inflammation develops in response to cell death and further contributes to the destruction of the lesion. Significant edema may occur, especially where the skin is loosely attached to underlying tissues, for example, the dorsum of hand and around the orbital region. Histological changes first become apparent 30 minutes after cryotherapy. Eosinophilia and vacuolation of the cytoplasm appear initially, and the entire cytoplasm becomes homogenized over the next few hours. This is accompanied by nuclear pyknosis. There is separation at the dermoepidermal junction, resulting in blister formation. At two hours, edema, focal capillary damage, and isolated microthrombi are seen; at five to eight hours, there is segmental necrosis of blood vessels. There is initially a wet exudative wound, nature's own biologic dressing, followed by a dry eschar and, usually within a month, a well-healed hypopigmented scar.

## Lesion Selection

Accurate diagnosis is essential to determine duration of the freeze required. An appropriate biopsy of the lesion should be performed if there is any diagnostic uncertainty. If a punch biopsy specimen is taken from the center of the lesion, information regarding the thickness of the tumor will also be gained. Vast experience in the treatment of numerous and varied skin lesions by cryosurgery has been accumulated over the past 30 years since this treatment was popularized by Zacarian for skin neoplasms (5,6). Much of this experience is summarized in Tables 50.1 to 50.4, while that pertaining to skin cancer can be found elsewhere (7).

## Vascular Lesions

Spider nevi require only a light freeze. A five-second single FTC is usually ample. Cryosurgery is a good alternative to fine-wire diathermy for people with pale complexions, especially for diffuse lesions with more than one feeding vessel. Diffuse telangiectasia, such as that associated with rosacea, can also be treated with good results and is a substantially cheaper alternative to the use of a pulsed dye laser.

Pyogenic granulomas also respond well (Fig. 50.3). Cryosurgery is also useful for palliation of HIV-associated Kaposi's sarcoma. Small individual lesions (and a 3-mm margin) can be

**Table 50.1** Suggested Treatment Regime for Disturbances of Pigmentation and Melanocytic Lesions

Lesion	Technique	Time, number of FTCs	Margin	Sessions and interval	Response
Melasma	OS	Uniform ice formation, $\times 1$	Feathering	4–6 weekly according to response	Moderate
Idiopathic guttate hypomelanosis	OS	5 sec, $\times 1$	1 mm	4–6 weekly according to response	Moderate to good
Tattoos	OS	30 sec, $\times 2$	1 mm	4–6 weekly according to response	54% improved
Freckles	P	Uniform ice formation, $\times 1$	Feathering	Usually only single treatment required	Variable
Lentigo simplex	Os or P	Light, $\times 1$	Feathering	Usually only single treatment required	Good
Solar lentigo	Os or P	5–10 $\times$ , $\times 1$	Feathering	Usually only single treatment required	Good

Abbreviations: OS, open spray technique; P, cryoprobe technique; FTS, freeze-thaw cycle.

**Table 50.2** Suggested Treatment Regime for Vascular Lesions and Nevi

Lesion	Technique	Time, number of FTCs	Margin	Sessions and intervals	Response
AIDS related Kaposi's sarcoma	OS	10–30 sec, ×2	3 mm	3 at 3 weekly intervals	80% improved
Venous lake	P	10 sec, ×1	1 mm	Usually only single treatment	Excellent
Cherry angiomas	P	10 sec, ×1	1 mm	Usually only single treatment	Good
Angiokeratoma of Mibelli	OS or P	10 sec, ×1	1 mm	3 at 2 monthly intervals	Good
Angiokeratoma of the scrotum	OS or P	5–10×, ×1	1 mm	3 at 2 monthly intervals	Good
Spider nevus	P	10 sec, ×1	1 mm	3 at 6 weekly intervals	Good
Capillary hemangioma	P	5–30 s, ×2	1 mm	2–4 at 8 weekly intervals	Excellent
Cavernous hemangioma	P	5–30 s, ×2	1 mm	2–4 at 8 weekly intervals	Excellent
Pyogenic granuloma	P	15 sec, ×1	1 mm	1–2 at 4 weekly intervals	Excellent

Abbreviations: OS = pen spray technique; P, Cryoprobe technique; FTS, freeze-thaw cycle.

**Table 50.3** Suggested Treatment Regime for Cysts, Tumors, and Nevi

Lesion	Technique	Time, number of FTCs	Margin	Sessions and intervals	Response
Acne cyst	OS or D PB to peeling	5–15 sec, ×1	–	2–3 at monthly intervals	Good to excellent
Milia	P	Ice formation ×1	1 mm	Usually only single treatment	Good
Myxoid cyst	P or OS	30 sec, ×2	1 mm	1–3 at 8 weekly intervals	86% improved
Syringoma	P	Ice formation ×1	1 mm	2–3 at 1–2 monthly intervals	Good
Trichoepithelioma	P	Ice formation ×1	1 mm	2–3 at 1–2 monthly intervals	Good
Trichilemmal cyst	OS	Ice formation ×1	1 mm	2–3 at 1–2 monthly intervals	A minority respond
Steatocystoma multiplex	OS	Ice formation ×1	1 mm	2–3 at 1–2 monthly intervals	A minority respond
Skin tag	OS or forceps	5–10 sec, ×1	1 mm	Usually only single treatment	Excellent
Hidrocystoma	OS or P	Ice formation ×1	1 mm	2–3 at 1–2 monthly intervals	Small-good, Large- poor
Dermatofibroma	OS or P	30 sec, ×1	2 mm	1–3 at 1–2 monthly intervals	90% improved
Seborrheic keratosis	OS or D or P	Ice formation ×1	1 mm	Usually only single treatment	Excellent
Sebaceous hyperplasia	OS or P	5–15 sec, ×1	1 mm	Usually only single treatment	Good
Chondrodermatitis nodularis helices	OS or P	15 sec, ×1	2 mm	2–3 at 1–2 monthly intervals	15–20% improved
Verrucous nevus	OS	5 sec, ×1	1 mm	Up to 5 at 1–2 monthly intervals	Excellent
Hyperkeratosis nevoid of the nipple	OS	20 sec, ×1	1 mm	Up to 5 at 1–2 monthly intervals	Excellent
Acrokeratosis verruciformis	OS	5 sec, ×1	1 mm	Several at 6–8 weekly intervals	Excellent
Dermatosis papulosa nigra	OS or P	Ice formation ×1	Nil	Several at 6–8 weekly intervals	Excellent, but may depigment
Benign lichenoid keratosis	OS	5 sec, ×1	1 mm	2–3 at 6–8 weekly intervals	Good
Adenoma sebaceum	OS	5–20 sec ×1	1 mm	3–6 at 3 weekly intervals	Satisfactory

Abbreviations: OS, Open spray technique; P, Cryoprobe technique; FTS, freeze-thaw cycle; D, freeze-thaw cycle.

**Table 50.4** Suggested Treatment Regime for Various Other Conditions

Lesion	Technique	Time, number of FTCs	Margin	Sessions and intervals	Response
Keloid	OS or P	15–30 sec, ×1	1 mm	5–10 at 4–8 weekly intervals	Variable
Acne scar	OS	Face 5 sec, ×1 Back 5–15 sec, ×1	1 mm	1–3 at 4–8 weekly intervals	Good to excellent
Rhinophyma	OS	30 sec, ×2	Entire nose	4–6 at 8 weekly intervals	Satisfactory
Xanthelasma	OS	5 sec, ×1	1 mm	2–3 at 4–8 weekly intervals	Satisfactory
Alopecia areata	D	2–5 sec, ×1	Nil	4 at weekly intervals	Satisfactory
Porokeratosis plantaris discreta	OS	Ice formation ×1	2 mm	2 at 2 weekly intervals	90.5% improved
Elastosis perforans serpiginosa	OS	10 sec, ×1	1–2 mm	2 at weekly intervals	Excellent

Abbreviations: OS, open spray technique; P, cryoprobe technique; FTS, freeze-thaw cycle; D, freeze-thaw cycle.

treated with a 15- to 30-second single FTC, with an 80% complete response. Cryoprobes are useful when treating venous lakes, since they allow the operator to empty the lesion during treatment, which leads to lower tissue temperatures and higher cure rates. A single 10-second FTC is usually sufficient.

There is a great variation in the size and depth of cavernous and capillary hemangioma, and this is paralleled by the variation in freeze times required. For small thin lesions, a single 5-second freeze may suffice, while for larger lesions a 30-second double FTC will be required. Experience in the



**Figure 50.3** Pyogenic granuloma (A) before and (B) after cryospray.

treatment of these lesions allows the operator better judge the length of treatment required.

### Acne

The first treatment to be advocated for acne was a solid carbon dioxide slush that acted as a peeling agent to reduce the oiliness of the skin and hastened the resolution of comedones and papules as well as improving depressed pitted scars. This was superseded by cotton-tipped applicators dipped in liquid nitrogen, which has also been used for larger acne cysts. Better results and better control can be achieved with the open spray techniques (8). Small inflammatory papules require a 2- to 5-second single FTC, while the large cystic lesions of acne conglobata may require a 15- to 20-second single FTC, depending on their size.

Open spray liquid nitrogen has also been used as an alternative to dermabrasion and laser resurfacing for diffuse scarring (9). The skin surface is divided into squares, each about 4 cm on a side. Using the paintbrush technique, each segment is frozen for between 5 and 15 seconds, depending on the depth of the desired peel. Areas of hypertrophic scarring may require longer freezes because of the relative cold insensitivity of collagen, while areas around the eyes, where the skin is thin, only requires 5- to 10-second single FTCs. If more than one treatment is planned, one month is the suggested interval between sessions. Of the patients so treated, 95% were reported to have had good or excellent results, which were similar to those achieved by superficial dermabrasion, with the advantage of their use in the presence of active acne.

### SUN-DAMAGED SKIN AND FACIAL PEELING

Solar keratoses, solar lentigines, solar elastosis, sebaceous hyperplasia, colloid milium, and the fine wrinkles of solar aging are all within the realms of unsightly sun-induced lesions amenable to cryosurgery.

These lesions occur on highly visible sites, such as the face and hands, and may cause patients distress. Cryosurgery is an excellent option for limited disease. Many clinicians ignore sebaceous hyperplasia; however, a single five-second FTC will

often make these lesions disappear. The same applies to solar elastosis, solar lentigo, and many solar keratoses.

For widespread changes full-face cryopeels can be used for effective depth-controlled removal of actinic keratoses, pigmented lesions, and seborrheic keratoses. Healing begins immediately and is usually complete within 10 days. The skin is left smoother, pinker, and tighter, and the results are equivalent to those of a chemical peel; however, there is greater control of the depth of the ice field, so it can be adjusted to accommodate localized lesions.

### Viral Warts

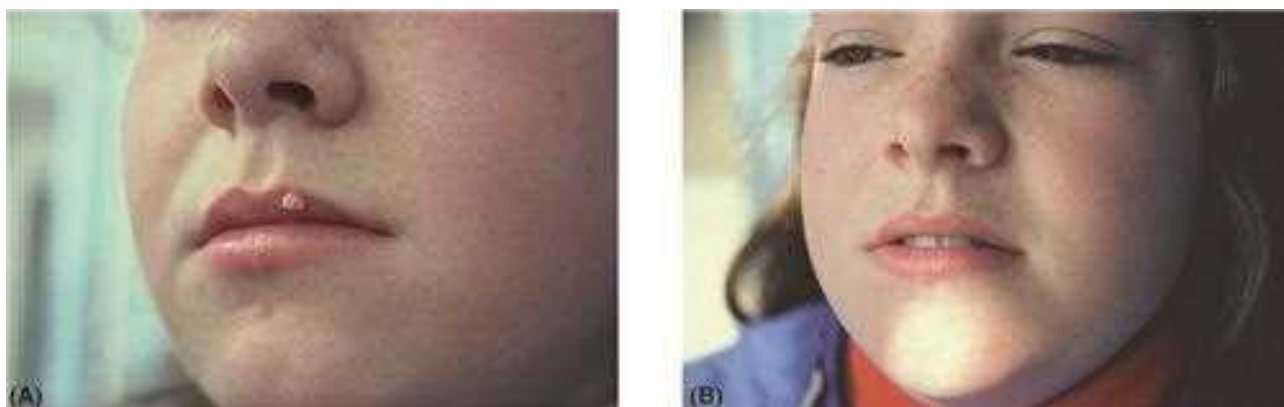
These are due to the human papillomavirus. On different body sites, warts often show different morphologic types. The cryosurgical treatment scheduled will vary with the site and type:

*Common warts* are mainly seen on hands, fingers, and knees. For flat lesions, a single freeze-thaw cycle using the open spray for 10 seconds is generally sufficient for an initial treatment. For hyperkeratotic wart, it is often best to pare the keratosis prior to freezing. Periungual warts often require multiple freezes with gradually increasing dose. The spray should be directed laterally to avoid overfreezing the nail matrix and to prevent pterygium.

*Plane warts* are smooth, small, flat-topped papules most commonly seen on the back of the hands and around the mouth. They are often multiple and can Koebnerize. Each wart should be frozen individually using the open spray with an E tip for 3- to 5-second single freeze.

*Plantar warts (verrucae)* typically occur on weight-bearing areas of the sole. Prior to cryosurgery, they should be pared to remove excess hyperkeratosis, then frozen with the open spray and a B or C nozzle for 10 to 20 seconds depending on size and thickness. Repeat treatments at three to four weekly intervals are generally required. For recalcitrant lesions a double freeze thaw should be used.

*Filiform or digital warts* are finger- or frond-like warts and are most common on the face, neck, and scalp (Fig. 50.4). Each lesion should be sprayed with a fine "needle" to ice formation plus 10 seconds of continued spray. Treatment may need to be repeated after two to four weeks.



**Figure 50.4** Filiform wart of upper lip (A) before and (B) after fine “needle” cryospray.



**Figure 50.5** Large seborrheic keratosis of right cheek (A) before and (B) after cryospray.

### Seborrheic Keratosis

Flat lesions can be effectively treated with a five-second single FTC (Fig. 50.5), but as keratin insulates the underlying epidermis from the cold, large hyperkeratotic lesions may still survive 30-second double FTCs. The main pitfalls of treatment are the induction of permanent alopecia, if hair-bearing areas are treated, and the induction of transient hyperpigmentation. It is for that reason that dermatosis papulosa nigra occurring on pigmented skin is best treated cautiously, and preferably with a test patch of a single lesion.

### Rhinophyma

Cryosurgery has been used to treat rhinophyma (10). However, in our hands, it has proved to be less effective than dermabrasion or serial shaving. Thirty-second double FTCs are recommended and can often be performed without anesthesia, or solely with EMLA cream. Multiple treatments are required, but are well tolerated. For mild cases, cryosurgery can still be considered as an inexpensive option with low risk and low morbidity that has shown some success.

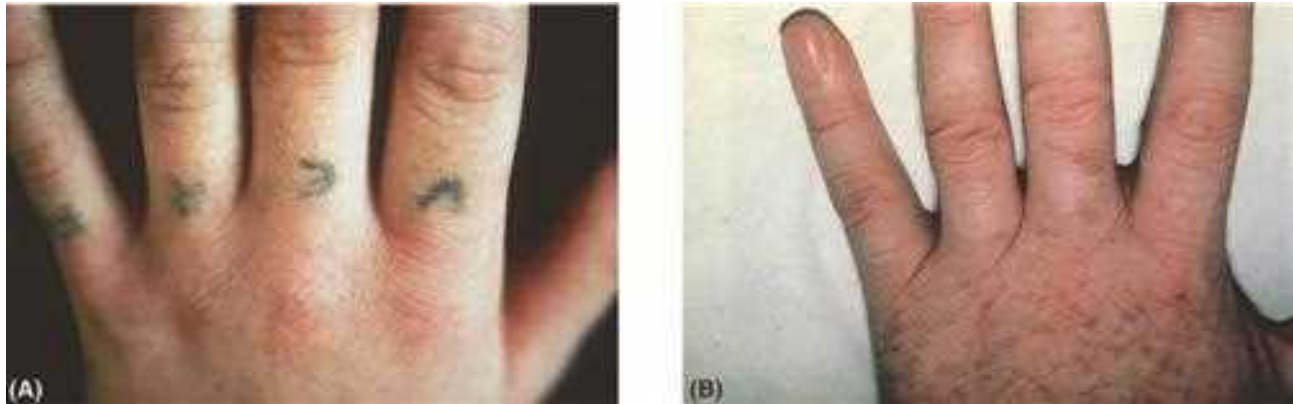
### Tattoos

Good results have been seen after cryosurgery of tattoos in up to 50% of cases (Fig. 50.6) (11). However, other modalities are now preferred, since a favorable outcome is more predictable. Nevertheless, for some patients desperate for the treatment there is no affordable alternative.

### Keloids

Many cryosurgeons disappointed by the apparent poor response of keloids to liquid nitrogen abandoned this form of treatment. Various techniques had been tried, including prophylactic and intralesional cryotherapy, without success. The poor response was attributed to the relative resistance to cold of fibroblasts and collagen.

It has suggested that previous treatment failures were due to impatience, and that often a keloid that has not responded to two or three treatments at monthly intervals will begin to respond after the third or fourth. The protocol advocated suggests that a cryoprobe be used to induce a 30-second single FTC (12). As there is no completely



**Figure 50.6** Tattoos (A) before and (B) four months after liquid nitrogen spray.

satisfactory alternative treatment for keloid, perhaps the time has come to revisit cryosurgery.

### COMPLICATIONS

Inflammatory morbidity, inevitable side effects, and complications are difficult to separate with this modality of treatment (13). Table 50.5 shows some of the well-known complications of cryosurgery. Some degree of pain is universal, but its intensity is extremely variable. Syncope can occur if the pain is severe, and many prefer to treat patients (particularly young men) lying down. During the freeze time, pain is felt as burning, and during the thaw phase, when pain is commonly worse than during the freeze, it is felt as throbbing. The periungual region and the temples are the most persistent. Headache is an occasional sequela after treatment of sites close to bone, such as the forehead, temple, or scalp.

Immediate hemorrhage, if occurs, is often prolonged, but can usually ultimately be stopped with pressure alone. This can follow by performing biopsies immediately prior to treatment,

but can also occur if a pedunculated lesion is manipulated while frozen and cracks.

Edema is the product of acute inflammation. Pronounced idiosyncratic edema may occasionally occur after short freezes. Edema is often more severe around the eyelids and lips (Fig. 50.7). The edema can be partly inhibited by a single application of a potent topical steroid immediately following treatment (14), and if severe edema is anticipated then systemic corticosteroids can be used.

Temporary hyperpigmentation is common in people with an olive complexion and may last two to three months. Careful sun protection following treatment may reduce this risk. For patients with Fitzpatrick types III and IV skin, even temporary hyperpigmentation may be unacceptable and treatment of a small test area is recommended.

Hypopigmentation is virtually universal following tumor doses of cryosurgery, owing to the exquisite sensitivity of melanocytes to cold, and can occur unpredictably following lower doses. In pigmented skin, this will lead to an unacceptable cosmetic result; however, in fair-skinned people this is usually

**Table 50.5** Side Effects of Cryosurgery

#### Immediate

- Pain
- Headache
- Hemorrhage
- Edema and blister formation
- Syncope

#### Delayed

- Infection
- Hemorrhage
- Excessive formation of granulation tissue
- Prolonged but usually temporary*
- Hyper pigmentation
- Milia
- Hypertrophic scars
- Alteration of sensation

#### Prolonged and usually permanent

- Hypopigmentation
- Alopecia
- Atrophy
- Ectropion
- Notching of the eyelids, ear, or vermillion border



**Figure 50.7** Left upper facial and periorbital edema 24 hours after two 30-second freeze-thaw cycles to left temple basal cell carcinoma of 2.4 cm in diameter.

**Table 50.6** Contraindications to Cryosurgery

Agammaglobulinemia
Blood dyscrasias of unknown origin
Cold intolerance
Raynaud's disease
Cold urticaria
Cryoglobulinemia
Pyoderma gangrenosum
Collagen and autoimmune disease

not a problem and can be dealt with by feathering. Any loss of pigmentation is permanent; but because the texture of the underlying skin is normal, it can be effectively disguised by cosmetics.

Feathering is a technique described to minimize the contrast between normal and hypopigment skin. It involves a light spray around the outer margin of the ice field after the treatment.

Alopecia will follow large doses of liquid nitrogen, and occasionally occurs at lower doses in an unpredictable fashion. Like pigment loss, any hair loss is usually permanent, and so cryosurgical treatment of lesions in the scalp and beard areas is generally only considered for small lesions.

Scarring and wound contraction do not occur if the duration of the freeze after ice formation does not exceed 30 seconds, but can occur with higher doses (15). This is due to the relative resistance of fibroblasts and collagen fibers to cold, which leads to the preservation of the fibrous tissue network, which then acts as a scaffold on which wound healing occurs. Cartilage is similarly cryoresistant, allowing lesions on the ears and nose to receive full 30-second double freezes of liquid nitrogen without distortion of normal tissue contour (16).

Sensory impairment following cryosurgery has been described in both the patient and the operator (17). Touch, pain, and cold sensations are all reduced and may take as long as 18 months to recover. The extent of sensory impairment is more pronounced with longer freeze times. Although this may be of advantage for repeat treatment of lesions or if analgesia is desired, patients must be warned of this complication if sensitive areas such as the fingertips are being treated. Neuropathy has been described when treating tumors on the side of the neck, near elbow or knee, and on the side of the finger. This is temporary persisting usually for three to six months.

Contraindications to cryosurgery generally relate to intercurrent illnesses such as those listed in Table 50.6. Relative contraindications arise with certain lesions where the cosmetic result would be more favorable with different treatments, such as the beard areas or in patients with pigmented skin, or in sites where wound healing may be slow, such as the pretibial region. Cryosurgery can still be used on all these lesions, as long as the operator acknowledges that the cosmetic outcomes will be diminished.

## CONCLUSIONS

As can be seen from the broad range of conditions listed in the tables, distinguishing between the use of cryosurgery for the treatment of the disease and cosmetic usage is sometimes difficult. Many pathologies cause little functional impairment but cause psychological morbidity through their perceived unpleasant appearance. To dismiss these disorders as trivial or unworthy and merely of cosmetic significance is to deprive the patient of balanced informed opinion.

For many of these conditions there are few published data that specifically address how to perform the actual treatment. This is because experienced cryosurgeons will be able to judge the treatment required on the basis of the pathology of the lesion, its thickness, and its site. For instance, a lesion on the lower leg of a person with venous insufficiency is likely to respond to shorter freeze times, and may have prolonged healing times. Even if all these treatments had been prospectively audited, more exact treatment protocols would be difficult to produce, since they would not allow for the many factors clinicians take into account when performing cryosurgery.

One reason why clinicians may obtain unsatisfactory outcomes is the use of inadequate treatment schedules. It is hoped that this description of the correct technique will ensure that others achieve results similar to those presented here. Cryosurgery is easy and can be learned quickly—but that is not the same as saying no training is required. As Zacarian, the father of modern-day cryosurgery, said, "A level of knowledge permitting an adequate understanding of the diagnosis and the pathophysiology of the condition to be treated must be a prerequisite. This is to be combined with a degree in skill in dermatocryosurgical procedures to allow the selection of those methods necessary to carry out the treatment plan. These skills must be acquired. There are no shortcuts."

## REFERENCES

- White AC. Liquid air; its application in medicine and surgery. *Med Rec* 1898; 56:109-112.
- Pusey W. The use of carbondioxide in the treatment of nevi and other lesions of the skin. *JAMA* 1907; 49:1354-1356.
- Colver GB, Dawber RPR. Malignant spots: spot freezes. In: Robins P, ed. *Surgical Gems in Dermatology*. Vol 2. New York/Tokyo: Igaku-Shoin, 1991:14-17.
- Graham GF. Cryosurgery: a useful tool inn the treatment of selected infectious diseases. *Int J Dermatol* 1994; 33:107-108.
- Dawber RPR, Colver G, Jackson A. *Cutaneous Cryosurgery. Principles and Practice*. London: Martin Dunitz, 1997:139.
- Zacarian SA, ed. *Cryosurgery for Skin Cancer and Cutaneous Disorders*. St Louis: Mosby Press, 1985.
- Korpan NN. In: Korpan NN, ed. *Basics of Cryosurgery: Cryosurgery of Cancers*. New York: Springer, 2001:58-108.
- Graham G. Cryosurgery for acne. In: Zacarian SA, ed. *Cryosurgery for Skin Cancer and Cutaneous Disorders*. St Louis: Mosby Press, 1985:59-76.
- Chicarello SE. Full-face-cry (liquid nitrogen) peel. *J Dermatol Surg Oncol* 1992; 18:329-332.
- Sonnex T, Dawber RPR. Rhinophyma: treatment by liquid nitrogen cryosurgery. *Br J Dermatol* 1983; 109(suppl 24):18.
- Colver GB, Dawber RPR. Tattoo removal using a liquid nitrogen cryospray. *Clin Exp Dermatol* 1984; 9:364-366.
- Zouboulis CC, Blume U, Buttner P, et al. Outcome of cryosurgical treatment in patients with keloids and hypertrophic scars. *Arch Dermatol* 1993; 129:1146-1151.
- Dawber RPR. Cryosurgery: complications and contraindications. *Clin Dermatol* 1990; 8:96-100.
- Hindson TC, Spiro J, Scott LV. Clobetasol propionate ointment reduces inflammation after cryosurgery. *Br J Dermatol* 1985; 112: 599-602.
- Shepard JP, Dawber RPR. Wound healing and scarring after cryosurgery. *Cryobiology* 1984; 21:157-169.
- Burge SM, Shepard JP, Dawber RPR. Effect of freezing the helix and rim or edge of the human and pig ear. *J Dermatol Surg Oncol* 1984; 10:816-819.
- Sonnex TS, Jones RL, Wedell AG, et al. Long term effects of cryosurgery on cutaneous sensation. *Br Med J* 1985; 290:188-190.



## Botulinum toxins

Doris Maria Hexsel and Arnold W. Klein

### INTRODUCTION

The cosmetic use of botulinum toxin (BT) on the upper face was first developed by Carruthers and Carruthers in the late 1980s (1). For this proposal, two types of BT are currently available: A and B. The first studies of the cosmetic use of BT were published in the early 1990s, and approximately 10 years later it was approved by the Food and Drug Administration (FDA) in the United States, and similar authorities in other countries. This represents one of the most important contributions to the approach of the aging face in recent years.

Easily applied by experienced physicians, BT injections are now perhaps the most frequently used cosmetic procedure. Their popularity and success among physicians and patients can be related to their consistent positive results and safety, besides being a fast, minimally invasive (2) and low-risk procedure. BT is now a recognized treatment for a wide spectrum of conditions characterized by relative overactivity of one or a few muscles (m.). BT injections are also effective in the treatment of localized hyperhidrosis (HH). The relative simplicity of the procedure and the lower rates of side effects or significant complications make this procedure increasingly attractive for cosmetic use.

Even though the anatomy of the facial musculature is well described, individual differences between patients, gender, population groups, and some characteristics, such as turgor and elasticity of the skin, are important factors to be considered before undertaking BT injections (3).

### PHARMACOLOGY AND MECHANISM OF ACTION

*Clostridium botulinum* produces an exotoxin that is considered the most poisonous of all poisons (4). It is an anaerobic, gram-positive bacillus that forms spores and that makes eight different antigenic structures with different functions: A, B, C1, C2, D, E, F, and G (5).

The currently available serotypes A and B result from modification of the protein structure. BT causes a temporary chemical denervation of the motor neuron in the treated muscle, resulting in therapeutic and cosmetic actions. It selectively inactivates these nerve terminals by blocking the release of acetylcholine, producing a temporary and ultimately reversible blockade of cholinergic transmission (6). In the neuromuscular junction, the blockade of the release of acetylcholine promotes a different spectrum of action (5,7), varying from muscle relaxation to muscular palsy, depending on the subtypes and doses used.

Table 51.1 shows the principal characteristics of the main commercial preparations of BTs.

### RECONSTITUTION, HANDLING, DILUTION, AND DOSE EQUIVALENCE

Available preparations of BT type A (BT-A) are usually stored in a refrigerator and reconstituted with isotonic sodium chloride (0.9% saline solution) with or without preservative (2) prior to their use.

The manufacturers of the commercial preparations of BT-A recommend their use within the first four or eight hours after reconstitution, depending on the product. The reason of these recommendations is to ensure that the potency of the drug is maintained and to prevent the possibility of contamination of the vials. However, a study showed no statistical differences in injections of BT-A from Allergan (Botox<sup>®</sup>) diluted up to six weeks prior to use (8) and also no microbiological contamination in the remaining liquid of the used vials (9). Another study showed the safety and efficacy of Dysport<sup>®</sup> after reconstitution up to 15 days after injection and also concluded no evidence of contamination and no loss of efficacy in the BT-A vials (10). BT type B (BT-B) (Myobloc<sup>®</sup>) remains stable if stored in a refrigerator for 30 months and at room temperature for 9 months (11).

Reconstitution of BT in smaller rather than larger volumes of saline solution is preferable. For cosmetic purposes, the higher concentration allows a low volume injection that permits more precise placement of the toxin. Table 51.2 shows the most common regular dilutions of Botox<sup>®</sup>/Vistabel and the recommended equivalent doses for Dysport<sup>®</sup>/Azzalure<sup>®</sup>.

A dose-equivalence of 1:2.5 U between Botox<sup>®</sup> and Dysport<sup>®</sup> is adopted by the most experienced physicians in the use of both products, and is mentioned in recent studies (12). This can also be inferred by comparing controlled studies that aimed to establish the optimal dose for glabellar area. Such studies demonstrated comparable results and optimal effects in treating glabellar wrinkles using doses of 20 U of Botox<sup>®</sup> (13) and 50 U of Dysport<sup>®</sup> (14,15), respectively. Hexsel et al. showed that injections of different commercial BT-A at an equivalence ratio of 2.5:1 U, respectively, applied at the same volume and depth, using the same technique resulted in similar field of effects with regard to muscular and sweat gland activity (16).

### CONTRAINDICATIONS, PRECAUTIONS, AND RECOMMENDATIONS

Contraindications and/or limitations for BT are listed in Table 51.3.

Pain and bruising at the injected sites are reduced by applying cold and pressure before and after treatment (20). The injections are usually painless if small syringes and fine-gauge needles are used (21). Injections should be performed slowly and superficially. Patients should remain in vertical position

**Table 51.1** Comparison of Different Commercial Preparations of BT Available in the Majority of the Countries

Active substance	Botox® 100 U	BT-A complex (925 kDa)	Vistabel® 50 U	Dysport® 500 U	BT-A complex	Dysport® 300 U	BT-A complex	Azzalure® 125 U	BT-A complex	Prosigne® 100 U	BT-A complex	Xeomin® 100 U	BT-A neurotoxin (150 kDa)	Neurobloc®/ Myobloc® 2.500/ 5.000/10.000 U
Suggested equivalence for cosmetic uses (relative to Botox®)	NA	NA	NA	Between 1:2 or 1:2.5 U	BT-A complex	Between 1:2 or 1:2.5 U	Between 1:2 or 1:2.5 U	Approx. 1:2 or 1:2.5 U	1:1	1:1	1:1	1:1	1:1000	BT-B complex
Mode of action—target protein	SNAP 25	SNAP 25	SNAP 25	SNAP 25	SNAP 25	SNAP 25	SNAP 25	SNAP 25	SNAP 25	SNAP 25	SNAP 25	SNAP 25	VAMP	
Pharmaceutical form	Lyophilized powder for injection	Lyophilized powder for injection	Lyophilized powder for injection	Lyophilized powder for injection	Lyophilized powder for injection	Lyophilized powder for injection	Lyophilized powder for injection	Lyophilized powder for injection	Lyophilized powder for injection	Lyophilized powder for injection	Lyophilized powder for injection	Lyophilized powder for injection	Lyophilized powder for injection	Reconstituted solution
Reconstitution	0.9% NaCl solution	0.9% NaCl solution	0.9% NaCl solution	0.9% NaCl solution	0.9% NaCl solution	0.9% NaCl solution	0.9% NaCl solution	0.9% NaCl solution	0.9% NaCl solution	0.9% NaCl solution	0.9% NaCl solution	0.9% NaCl solution	0.9% NaCl solution	Prepared solution, dilutable
Storage	2–8°C	2–8°C	2–8°C	2–8°C	2–8°C	2–8°C	2–8°C	2–8°C	2–8°C	2–8°C	2–8°C	25°C	2–8°C, do not freeze	24 mo
Shelf life (unopened)	36 mo	36 mo	36 mo	24 mo	24 mo	24 mo	24 mo	24 mo	36 mo	36 mo	36 mo	36 mo	36 mo	24 mo
Shelf life reconstituted	Up to 24 hr depending on country approval	Up to 24 hr depending on country approval	Up to 24 hr depending on country approval	4–8 hr	4–8 hr	4–8 hr	4–8 hr	4 hr	Up to 24 hr depending on country approval	4 hr	4 hr	Up to 24 hr depending on country approval	Up to 24 hr depending on country approval	NA
Auxiliary substances	Albumin 0.5 mg/vial NaCl 0.9 mg	Albumin 0.5 mg NaCl 0.9 mg	Albumin 0.5 mg NaCl 0.9 mg	Albumin 0.125 mg lactose 2.5 mg	Albumin 0.125 mg lactose 2.5 mg	Albumin 0.125 mg/vial lactose 2.5 mg	Albumin 0.125 mg lactose 2.5 mg	Albumin 0.125 mg lactose 2.5 mg	Albumin 1 mg, sucrose 4.7 mg	Gelatin 5 mg, dextran 25 mg, and sucrose 25 mg	Gelatin 5 mg, dextran 25 mg, and sucrose 25 mg	Albumin 1 mg, sucrose 4.7 mg	Albumin, NaCl, succinate, octanolate, tryptophan	Albumin, NaCl, succinate, octanolate, tryptophan
pH-Wert	5–7	5–7	5–7	5–7	5–7	5–7	5–7	5–7	5–7	5–7	5–7	5–7	5, 6	5, 6
Toxin protein load in dose-equivalence range	5 ng/100 U	2.5 ng/50 U	2.5 ng/50 U	5 ng/300 U	5 ng/500 U	5 ng/300 U	5 ng/125 U	5 ng/125 U	0.6 ng/100 U	4–5 ng/100 U	4–5 ng/100 U	0.6 ng/100 U	100 ng/10.000 U	100 ng/10.000 U

**Table 51.2** Regular Dilutions of 1, 2, and 2.5 mL for Botox<sup>®</sup>, Vistabel<sup>®</sup>, and Xeomin<sup>®</sup> Recommended by the Present Authors as an Equivalent Dose for Dysport<sup>®</sup>/Azzalure<sup>®</sup>

To achieve the equivalence between Botox <sup>®</sup> /Vistabel and Dysport <sup>®</sup> /Azzalure of	If the vial of 100 U (Botox <sup>®</sup> ) is usually diluted in	If the vial of 50 U (Vistabel) is usually diluted in	The vial of 100 U (Xeomin) is usually diluted in	The vial of 500 U of Dysport <sup>®</sup> should be diluted in	The vial of 300 U of Dysport <sup>®</sup> should be diluted in	The vial of 125 U of Azzalure should be diluted in
1:2.5 U	1 mL	0.5 mL	1 mL	2 mL	1.2 mL	0.5 mL
1:2.5 U	2 mL	1 mL	2 mL	4 mL	2.4 mL	1 mL
1:2.5 U	2.5 mL	1.25 mL	2.5 mL	5 mL	3 mL	1.25 mL

**Table 51.3** Contraindications for BT Injections

## Contraindications

- Pregnancy and breast-feeding
- Active infection in the proposed area
- Neuromuscular transmission disorders (myasthenia gravis, Eaton-Lambert syndrome, Rooke syndrome)
- Hypersensitivity to components of the BT-A injection solution (BT-A, human albumin)
- Medication that influences neuromuscular transmission such as quinine, calcium channel blockers, penicillamine, aminoglycoside antibiotics, pancuronium, galamine, tubocurarine succinylcholine
- Medication that interferes with coagulation (e.g., acetylsalicylic acid, anticoagulants, vitamin E) and coagulopathies
- Candidates with unrealistic expectations, unrealistic fears of the toxin, psychiatric disorders such as psychosis, mania, body dysmorphic disorder, and eating disorders

Abbreviation: BT, botulinum toxin.

Source: From Refs. 17–19.

after BT injections and avoid manipulating the injected area for at least four hours after injections. These measures may prevent the undesirable action of BT in adjacent muscles (17).

Injections should be symmetrical regarding doses, muscles, and areas. This is important for the natural balance of the facial structures (9) and to avoid asymmetries. Exception includes important and evident asymmetries, such as those caused by facial palsy.

Treatments are usually repeated twice a year for maintenance of the results. A period of 15 to 30 days for touch-ups should be respected. It is important to avoid more than one touch-up and respect the minimal interval of three to four months between treatment sessions, because of the risk of inducing the formation of antibodies. However there is no evidence of immunogenicity to BT for cosmetic use (22).

When BT is injected adjacently to some surgical procedures, such as facelift, blepharoplasty, and laser resurfacing, some physicians prefer to inject in the postoperative period (23).

The dose to be injected depends on the target muscle and can vary from patient to patient and from one application to another, according to patient's needs, muscle mass and activity of the target muscles, gender, and number of previous treatments.

The suggested doses of BT-A according to the area to be treated are given in Table 51.4. These represent the doses recommended by the consensus groups for Dysport<sup>®</sup> and Botox<sup>®</sup> (24–26).

Patients should read and sign the informed consent form before application, and photographs should be taken before all cosmetic procedures, to evaluate the results (18). Photographs must be taken at rest and also with contracted muscles. Makeup should be removed and the skin cleansed before application.

**Table 51.4** Suggested Doses of Botox<sup>®</sup> and Dysport<sup>®</sup> in Different Cosmetic Treatments

	Botox <sup>®</sup>	Dysport <sup>®</sup>
	Average total dose (U)	Average total dose (U)
Facial indications		
Glabellar lines	10–40	30–70
Forehead lines	6 to >15	20–60
Crow's feet	10–30	30–60
Infraorbital rhytides	2–4	5
Bunny lines	4–8	10–20
Nasal tip droop	2–3	10
Repeated nasal flare	4–10	10–20
Perioral area	4–5	4–12
Mentalis	4–10	10–20
Depressor angulis oris	3–6	10–20
Gingival smile	4–10	5–15
Masseteric hypertrophy	25–30	60–120
Platysma bands	40–60	50–100
Décolleté	30–100	75–120

Doses are expressed in total number of units per treatment divided in both sides, when applicable.

**UPPER FACE**

BT indications for the upper face include the treatment of glabellar lines, forehead lines, brow lifting, crow's feet lines, and the treatment of frontal or other focal forms of HH (27–31). HH treatment will be mentioned as other topic in this chapter.

The direction of facial wrinkles and lines is usually perpendicular to the direction of the muscle fibers. In the upper face, most wrinkles result from muscular action (32), and are considered "expression lines." The muscles of the upper face are intricately intertwined. In this area, location, muscle

anatomy, and muscle mass, as well as the way patients use their muscles vary greatly between individuals. The *frontalis* m. have a quite variable anatomy and are responsible for the horizontal forehead lines. These muscles are mainly responsible for raising the eyebrows, especially in aging people, who use these muscles to amplify the visual field. Muscles controlling the frown include the *corrugators* m. and the *orbicularis* m., which move the brow medially, while the *procerus* m. and the *depressor supercilli* m. pull the brow inferiorly. The *orbicularis oculi* m. is divided into three parts, the orbital, the preseptal, and the pretarsal portions.

**Glabellar Lines**

Glabellar lines (Fig. 51.1) are interpreted as presenting negative sentiments, such as sadness, anger, and frustration (13,33).

One or two injection sites may be used on the belly of the *procerus* m. This muscle is treated in the midpoint of an imaginary "X" formed by lines joining the inner brows and the contralateral inner canthus (34,35). If the *frontalis* m. is not treated, the middle to lateral portion of the eyebrows will be slightly raised by the opposing levator action of the *frontalis* m. (36). The conventional injection technique involves the observation of the medial aspect of the eyebrow, while the patient squints and frowns.

BT is slowly injected into the belly of the *corrugator* m., taking care to maintain the needle tip approximately 1 cm superior to the orbital rim (Fig. 51.2).

The needle should be positioned perpendicularly and advanced slightly within the muscle fibers in a vertical direction toward the hairline (36).

A variety of different injection techniques and doses have been reported over the years. They range from a single injection into the belly of each *corrugator* m. with total doses of 20 U of Botox® and 50 U of Dysport® (14,35), although doses can vary and be customized. The total doses of Dysport® for glabellar lines range from 30 to 70 U (35). A study has shown that injections of BT into five sites in the glabellar area using 4 U of



**Figure 51.1** Glabellar lines due to frowning of corrugators and procerus muscles.



**Figure 51.2** The five-point technique for glabellar lines: one in the procerus and two in each corrugator muscle.



**Figure 51.3** Upper face at rest before injections, showing the original position of eyebrows.

Botox® or 10 U of Dysport® per site is effective for reducing glabellar lines (37). The safety and efficacy of repeated treatments with BT for glabellar lines were shown and seems that increased benefits occur with successive treatments (2).

A study using Myobloc suggested that it may be used in selected cases with glabellar wrinkles not responsive to BT-A injections (38).

The eyebrow is a mobile structure elevated by *frontalis* m. and depressed by brow depressors (*orbicularis oculi* m., *corrugator supercilli* m., and *procerus* m.). BT-A treatment for glabellar lines causes an elevation of the medial and lateral brows (34,35) (Figs. 51.3 and 51.4), leading to a desirable shape and height of the brows (27). It was observed that the ideal brow shape in



**Figure 51.4** The same patient as in Figure 51.3, showing the brow lift after botulinum toxin injections.

women is the lateral and medial elevation, instead of medial elevation only (27). BT injections in both medial and lateral brow depressors produce elevation of the entire brow, leading to an arched shape (37), which is desired by women but not by men. Male brow pattern is rectilinear.

### Forehead Lines

The frontal region should always be treated in association with the glabellar area to avoid increased use of *glabellar* m., which are mainly depressors (35,39). It is also important to preserve the frontal muscle movements that are responsible for facial expression and lift of the eyelids and brows. Total paralysis of the *frontalis* m. can cause brow ptosis (36).

It is also important to point out that the *frontalis* m. are largely responsible for facial expressiveness. Therefore, multiple injections of small amounts of BT-A are used in this area to create only a weakening of the muscle instead of a total paralysis, preventing expressionlessness (36,40,41). The total dose varies from 6 to >15 U of Botox<sup>®</sup> (26) and 20 to 60 U of Dysport<sup>®</sup> (24).

### Periorbital or Crow's Feet Lines

The wrinkles radiate from the lateral canthus outwardly and laterally, and are perpendicular to the direction of the muscle fibers of the *orbicularis oculi* m. (36) (Fig. 51.5).

The total doses used to treat crow's feet lines range from 4 to 5U/side to 5 to 15U/side of Botox<sup>®</sup> or 5 to 10U/side to 15 to 30 U/side of Dysport<sup>®</sup> (24) (Fig. 51.6). These doses are generally distributed over two or three injection sites (35), although sometimes four to five sites are needed (Fig. 51.7).

All the injections must be performed at least 1 cm lateral to the lateral orbital rim. Intradermal injections made in the preseptal portion of the lower eyelid reduce these specific fine wrinkles (42). Infraorbital rhytides (Fig. 51.8) can be treated by 1 to 2 U/side of Botox<sup>®</sup> and 0.8 to 2.5 U/side of Dysport<sup>®</sup> (24), 3 to 4 mm below the eyelid.



**Figure 51.5** Crow's feet wrinkles, radiating from the lateral canthus, before treatment.



**Figure 51.6** The same patient as in Figure 51.5, after treatment with botulinum toxin.

### FACIAL ASYMMETRY

Facial asymmetry is a frequent complaint and can result from many different causes, which will determine whether it will be temporary or permanent (43,44). BT-A or BT-B injections are successful treatments for a variety of facial nerve palsies and facial dystonias.

BT-A can also be used to treat lesions or muscle hypertrophy resulting from surgical procedures or trauma, to achieve



**Figure 51.7** Superficial injections of botulinum toxin type A for the treatment of crow's feet wrinkles.

better cosmetic and functional results. Usually the BT-A injections are performed on the unaffected side of hemiparesis, treating the hyperkinetic muscles (23). BT-A can provide a simple, noninvasive, and safe way of correcting obtrusively distracting asymmetry (43).

Application of BT in the healthy side of the face can improve symmetry of the face at rest and during facial motion, especially when smiling, speaking, or exposing the teeth (45).

In treating asymmetries, the duration of the BT-A is generally shorter, due to the low doses required to achieve partial relaxation of the muscles, with normal contraction returning in approximately eight weeks.

## MIDDLE FACE

While the duration of the effects of BT-A injections in the upper face is about three to four months or longer, sometimes six to eight months, in the middle and lower face, only about two to three months can be expected. Other factors may lead to a decrease in duration (46). These include the technique and doses, individual differences, and previous treatment with BT-A.

The most important wrinkles in the middle face are nasal wrinkles. The *levator labii superioris* m. and *nasal* m. as well the medial portion of the orbicularis (47) are involved in these wrinkles.



**Figure 51.8** Points for botulinum toxin injection in infraorbital rhytides and bunny lines.

## Bunny Lines

Nasal wrinkles, called “bunny lines” (Fig. 51.8), are treated with low doses of BT-A (48). These lines may become more pronounced after BT injections for the treatment of glabellar and periorbital wrinkles. The injection must be applied in the high lateral nasal wall, below the angular vein, avoiding injections near the nasofacial groove to prevent relaxation of the *levator labii superioris* m., which may lead to upper lip ptosis (48,49).

The recommended dose is 4 U of Botox<sup>®</sup> and 5 to 10 U of Dysport<sup>®</sup> (25) intradermally at just one point on each side.

The treatment may be less effective in patients who recruit these muscles excessively or have had prior rhinoplasty (48).

## Nasal Tip Droop

The *depressor septi nasi* m. is a small muscle located in the external inferior base of the nasal septum, which contributes to the nasal tip lowering, aggravating the nasal tip ptosis that usually occurs with aging. Injections are done at the base of the columella (48). BT injection of 2 to 3 U of Botox<sup>®</sup> (26) and 5 to 10 U of Dysport<sup>®</sup> (25) in a single site at the junction of the columella and the upper lip can result in partial lifting of the tip of the nose.

## Repeated Nasal Flare

Some people present dilate or rhythmic contractions of the nostrils on certain occasions, which may cause embarrassment. Injections of BT-A are indicated on each side in the lower nasal fibers above the lateral nasal ala (48).

## LOWER FACE

Lower doses of BT than those usually used in the upper face are recommended for the lower face. Such doses permit muscle relaxation instead of paralysis of target muscles, which is desirable for this area (50). However, there are no specific doses or specific recommended techniques for BT injections, as muscles vary in size or muscle mass, location, force of

contraction, and function between patients, as described for the upper face.

Because of the low doses used to treat the lower face, it is recommended to inject lower face together with upper face. Care should be taken not to inject all areas in the lower face because of the increased risk of the accumulated effects and doses in this area, increasing the risks of side effects.

Most of the muscles of the lower face are functionally related to the mouth and lips (49). In the lower face, BT is useful to treat a series of conditions, including perioral wrinkles, masseteric hypertrophy, "peau d'orange" chin (*mentalis* m.), marionette lines (*depressor angulis oris* m.) as well as gingival and asymmetric smile.

### Perioral Area

Photodamage, heredity, cigarette smoking, loss of deep structures volume, sleep positions, orthodontic deformities, and dynamic component like playing a musical instrument that requires embouchure, or even whistling have been thought to cause this aesthetic problem (48,51). Fine, vertical lip rhytids are also caused by repetitive action of the *orbicularis oris* m.

Tiny doses of BT produce localized microparesis of the *orbicularis oris* m. reducing dramatically perioral lines and also giving a pleasant pseudoeverision of the lip, with enhancement of the vermilion contour (48).

The patient is asked to pucker and the adjacent areas of muscle contractions are marked. It is recommended to inject low doses and, superficially, above the vermilion ridge in the area of muscle contraction adjacent to the creases, away from the oral commissures and Cupid's bow.

Caution is required for musicians who play wind instruments, professional singers, speakers, or actors, because of the chance to have difficulties with lip proprioception after treatment.

The total dose varies from 4 to 10 U of Botox<sup>®</sup> (26) and 4 to 12 U of Dysport<sup>®</sup> (25).

### Mentalis and Depressor Angulis Oris

*Mentalis* m. cause wrinkles giving the chin a dimpled or "cellulitic" aspect (Fig. 51.9). These muscles can be treated with one



**Figure 51.10** Treatment of mentalis with 3 U of botulinum toxin on each side.

injection in the midline or two injections in each side of the insertion of these muscles at the point of the prominence of the chin (Fig. 51.10), with good results (Fig. 51.11) (46). Deep injections are suggested because of the reasonable amount of fat that exists in the chin area (52). The total doses of 4 to 10 U of Botox<sup>®</sup> (26) or 10 to 20 U of Dysport<sup>®</sup> (25) are recommended.

The *depressor angulis oris* m. is responsible for lowering the corner of the mouth; this worsens the nasolabial fold, producing the so-called "marionette" lines and thus giving a negative expression to the patient (Figs. 51.10 and 51.11). These muscles can be treated with injections of BT at the border



**Figure 51.9** "Cellulitic" aspect of the chin before treatment.



**Figure 51.11** The same patient as in Figures 51.9 and 51.10, after botulinum toxin treatment of the mentalis. The depressor angulis oris was not treated.

of the jaw bone, at a point on an imaginary line descending from the nasolabial fold. The total range dose varies from 3 to 6 U of Botox<sup>®</sup> (46) or 10 to 20 U of Dysport<sup>®</sup> (25). Lower lip dysfunction can be caused when the injection is too medial and high, reaching the *depressor labii* m. (20).

### Gingival Smile

Gingival display was defined as the difference between the lower margin of the upper lip and the superior margin of the right incisor (53). Excessive upper gum exposure occurs when more than 3 mm of gingival is exposed when someone smiles and is called "gingival smile."

This is a consequence of excessive retraction of *levator labii superioris alaeque nasi* m. BT-A injected into the *levator labii superioris* m. causes a slight to moderate drop of the upper lip, reducing the gummy exposure. The total dose of Botox<sup>®</sup> is 4 to 10 U and the total dose of Dysport<sup>®</sup> is 5 to 15 U. The result is effective and statistically significant at 2 weeks after injections and sometimes lasts for 24 weeks (54). Results are less satisfactory in middle-aged and older patients, as this causes vertical elongation of the upper lip.

### Asymmetric Smile

Asymmetry occurs when one of bilateral muscles is comparatively stronger or weaker than other. Three basic types of facial asymmetries (FA) have been described and result from different causes. The acquired FA is the result of a medical or physical episode, for instance, a cerebral vascular accident. FA can also be the result of iatrogenic causes as in the case of certain types of surgery on the face. A third type of FA can be idiosyncratic or familial, in which a muscle on one side of the face can be comparatively stronger or weaker than its partner muscle on the contralateral side of the face (43).

The most common cause of asymmetric smile is related to *depressor labii inferioris* m. hyperkinesis or weakness. The total doses of 1 to 3 U of BT-A (Botox<sup>®</sup>) injected into the belly of the hyperkinetic muscle have been reported to treat the asymmetry (43). The results became evident in less than five days and the effects last four to five months after the first treatment. In subsequent treatments, it is recommended to reduce the doses, and the results are usually longer (43).

### Masseteric Hypertrophy

The hypertrophy of *masseter* m. is a rare, asymptomatic problem of unknown cause. It can be unilateral or bilateral and may also be related to bruxism. Usually it begins during infancy and may determine a more square shape of the face. BT-A can safely be considered as a noninvasive drug treatment for patients with *masseteric* m. hypertrophy (55).

Injections are given 1 cm below and above a reference line drawn from the tragus of the ear to the corner of the mouth. About 44% of patients would complain reduction of mastication strength (17). Its effectiveness is noticed as early as two weeks after injections and reached a peak effect in three months. Six months after the injections, the facial contour gradually returned to the original shape and volume (56). The patients can be treated again every three to four months, if needed. Doses are high, 25 to 30 U of Botox<sup>®</sup> (26) and 60 (for caucasian) to 120 (for Asian) U of Dysport<sup>®</sup> (25).

## PLATYSMAL BANDS AND DÉCOLLETÉ WRINKLES

*Platysma* m. are a pair of flat muscles that originate in the subcutaneous of the upper thorax, ascend laterally to the lower face, cross the neck, pass behind the mandible angle, and insert into the cutaneous muscles around the mouth (57). They are the result of the repeated and strong contractions of these muscles.

Neck wrinkles emerge as a result of the links of the superficial musculoaponeurotic system (SMAS) to the skin (58). Besides the muscular effects, neck wrinkles also result from flaccidity and photoaging (47).

Platysmal bands are better visualized when the patient shows the lower teeth. They become more apparent when the patient moves the neck while speaking, exercising, smiling, or playing musical instruments (58). BT has been used for several years to reduce or prevent such alterations (58). In this indication, BT should be injected at various points along the length of the bands, at distances of 1 to 2 cm. The total dose of Botox<sup>®</sup> (26) for platysmal bands is 40 to 60 U and 50 U of Dysport<sup>®</sup> (24,57). However, the risk of complications with high doses can exceed the potential benefits.

The main platysmal bands are chosen to be treated in each session (usually two to four bands) (48). This results in improvement of the appearance of the bands and fine wrinkles. In older people, it can reduce wrinkles and bands in cases where the surgical lifting is contraindicated or when there are postsurgical residual wrinkles (47). Greater benefits are seen in patients with apparent bands, good elasticity of the skin, and minimal fat deposition in this area (58).

Cutaneous wrinkles in the décolleté area can be classified as dynamic wrinkles, static wrinkles, and combined wrinkles. They result from several factors, such as photoaging (main cause), intrinsic aging, muscular contraction of the pectoralis major and lower part of the platysmal bands, as well as sleep position. BT relaxes the underlying muscles, improving these wrinkles (57). Doses of 2.5 U of Botox<sup>®</sup> and 7.5 to 10 U of Dysport<sup>®</sup> can be used at each injection site in a V-shaped technique. The total dose of 40 to 60 U of Botox<sup>®</sup> and 75 to 120 U of Dysport<sup>®</sup> (24) is used, improving décolleté wrinkles in selected patients in about two weeks (59).

## ADJUNCTIVE

Facial wrinkles are the result of a combination of many causes. It has been shown that the best approach for treating facial wrinkles is a combination of techniques.

Numerous minimally invasive techniques are available, which are complementary and synergistic to BT. The combined use of BT with other minimally invasive or invasive surgical treatments may significantly improve the results and their duration when compared to the same procedures used alone (58). BT injections may optimize and prolong the effect of the surface procedures, such as fractional lasers intense pulsed light, peelings, as well as fillers (hyaluronic acid, polylactic acid, and porcine collagen, etc.) (60) and Subcision<sup>®</sup>. The aim of combining procedures is to produce a more polished and refined result (48,61) (Fig. 51.12).

It has been demonstrated that the aesthetic improvement in severe glabellar rhytides is higher when combining BT-A (Botox<sup>®</sup>) with non-animal-sourced hyaluronic acid (NASHA, Restylane<sup>®</sup>) compared with NASHA (Restylane) alone. BT-A may play a protective role in the longevity of filler response in combined use in the glabella (62).





**Figure 51.12** Before (A) and after (B) lip augmentation with Surgiderm™ followed by application of botulinum toxin (Dysport®) in the perioral area.

Fillers can be combined with BT in perioral area to treat volume losses, a key component of perioral aging. Resurfacing techniques can also be used in combination in this area (54). The adjunctive usage of fillers into lip margin can be useful in gingival smile treatment (48).

For décolleté wrinkles, BT can be combined with other surgical techniques, such as peels, lasers, and surgical lift (57).

A study showed that patients may be treated with several nonablative lasers immediately after BT injection without loss of efficacy or other apparent untoward effect (63).

Although BT can be used in combination to surgical procedures, it has been shown that the combination of non-surgical therapeutic modalities provides improvement of facial skin texture, pigmentation, tone, and wrinkles, as well as an improvement in facial contour (61), and significantly increases the satisfaction rate of patients (64).

## HYPERHIDROSIS

Hyperhidrosis is a condition characterized by intense sweating in one or more areas of the body (65), mainly affecting axillae, palms, soles, face, thigh, and inguinal area (65–67). HH may cause significant physical, emotional, and/or social discomfort for patients, having a considerable impact in their quality of life (68).

The diagnosis is clinical, and the criteria for focal forms of HH are as follows (66): bilateral and relatively symmetric, impairs daily activities, frequency of at least one episode per week, age of onset less than 25 years, positive family history, and cessation of focal sweating during sleep.

Some tests are used to visualize (starch-iodine or Minor's test) and quantify (gravimetric test) the sweating. These tests are the most widely used for the visualization of the active sweat areas (69). Hexsel et al. provided suggestions in the performance of the Minor's test and presented a new scale (Sweating Intensity Visual Scale) to a better evaluation and interpretation of the results (69). Besides these methods, the Hyperhidrosis Area and Severity Index (HASI) has been developed to assess the HH condition taking into account not only the amount of secretion but also the size of the secreting area (70).

HH occurs due to the exacerbated perspiration of the eccrine sweat glands that are distributed over almost the entire body surface. There is a high density of these glands in some areas such as the sole of the feet and the forehead, followed by the palms and cheeks (71).

The function of apocrine and apoecrine glands in HH is unknown, but they are believed to play only a minor role in the pathophysiology of the condition (67). Sweating is controlled by nerve fibers that, anatomically, are distributed through the sympathetic nervous system (72).

BT-A is an irreversible inhibitor of acetylcholine release from the presynaptic membranes of neuromuscular junctions, preventing the release of this neurotransmitter on the postganglionic sympathetic fibers that act on the sweat glands (66). Since apocrine, eccrine, and apoecrine glands respond to cholinergic stimuli, subcutaneous injections of BT-A into the sweating regions result in complete cessation of sweating from all gland types (73). So far, no anatomical differences in sweat glands have been demonstrated between hyperhidrotic patients and control groups. But after BT treatment, morphological alterations in the gland ducts have been noticed (74).

Recent studies have shown that also BT-B is safe and efficacious for the treatment of axillary and palmar HH (75,76). Because of the lack of approval by the FDA, it has been used as an off-label treatment for HH (75).

HH can be primary, which is idiopathic, or secondary to various causes. The main causes of secondary HH are high temperatures, physical exercise, fever, anxiety, fear, other psychological symptoms, thyrotoxicosis, lymphoma, cancer, hypoglycemia, Frey's syndrome, nausea, neurological lesions, and some drugs, such as neuroleptics, antidepressant agents, and anxiolytic agents. In both cases, HH can be focal or generalized. The primary HH is a relatively common disorder, and it is usually localized and symmetrical (65).

Several treatments are used for HH, and most of them cause significant adverse effects (71) or have limited efficacy in severe cases (72). Available treatments for HH include topical, medical, and surgical treatments. The Canadian Hyperhidrosis Committee developed guidelines that provide a recommended

course of therapy for patients with different focal HH based on the severity of disease, which is evaluated through the Hyperhidrosis Disease Severity Scale (HDSS) (72).

BT-A in the treatment of focal HH is considered fast, safe, and efficacious, and rarely produces significant side effects (77). It is still the only type of BT approved by FDA to be used in the treatment of HH. The application is usually intradermal because the targets are the sweat glands, which are located 2.5 mm below the skin (67). The application of different dilutions in different depths has been and is still being tested to identify if those differences would produce diverse results, although there are evidences that these are much less important than dose and amount of sweating of the treated areas (78).

Ideal doses have been the focus of discussion, aiming to obtain more efficacious and lasting results. Absar and Onwudike related BT-A as an effective and well-tolerated treatment for axillary HH. The authors used 250 U of Dysport<sup>®</sup> as total dose. However, they recognize that this dose is relatively high, and they are evaluating the use of 100 U of Dysport<sup>®</sup> according to Heckmann's results (66,79). In a review, Lowe presented different treatment options to axillary and palmar HH, indicating 50 U and 60 to 100 U of Botox<sup>®</sup> as recommended doses, respectively (77).

Positive results in the treatment of inguinal HH with BT-A have been described by Hexsel et al. These authors show that the total recommended dose to treat inguinal HH is 100 U of Botox<sup>®</sup>, but they also considered that lower doses, between 60 and 80 U of Botox<sup>®</sup> can be used to treat less severe cases (67).

Glogau have described the use of topical applications of BT-A in the treatment of axillary HH. This technique appeared to be safe and showed statically significant quantitative reduction of sweat production (80).

An improvement in quality of life in treating HH with BT-A has also been demonstrated, as this condition interferes directly in daily routine (68).

The duration of the effects of BT treatment for the majority of focal forms of HH with average doses are from four to six months, approximately. The duration of the control of palmar HH has been indicated to vary from four to nine months (77), and the treatment of frontal HH for at least five months (77). BT treatment for axillary HH has been related to last in average seven months (71), while effects of inguinal HH treatment last usually six months or more with high doses of BT (67).

## COMPLICATIONS AND SIDE EFFECTS

The complications and adverse effects of the use of BT are usually transitory and, in most cases, technique dependent (39). There are isolated few reports of systemic adverse effects after BT injections with the use of doses larger than those usually recommended for cosmetic purposes (81).

The most common local adverse effects are pain, which is more intense in the perioral and nasal regions, and transitory edema and erythema, which increase proportionally with higher dilutions. Hematomas and ecchymoses (39,81) are more frequent in the upper face than in the lower face.

The most common complications in the lower face are related to higher doses or erroneous application of BT, which causes undesirable paralysis in the musculature, causing asymmetric smiling and complications due to the incompetence of the sphincter function of the mouth (81). Some symptoms appear as a consequence of lip movement difficulties, as in swallowing, speaking, smoking, whistling or playing wind instruments, involuntary biting of the tongue, lip parenthesis,

filter disappearance, and difficulties in specific lip movements, such as spreading lipstick with the lips and involuntary dribbling during speaking (39).

When treating the neck with BT injections, the most common complications are dysphagia and difficulties in flexing the neck and nodding (82).

In HH, besides the most common complications caused by the injection trauma, some transitory compromising of the adjacent musculature can occur (83). The main side effects are local pain during the application and, more rarely, reversible muscle weakness at the site of injection; as an example, the reduction of manual dexterity can occur, owing to the treatment of the palm with BT. Patients who perform minutely detailed activities with the hands, such as artisans, pianists, and others, deserve special attention (83). Residual HH and asymmetries are also reported as complications with the use of BT. In such cases, correction of asymmetries is made by reinjecting BT within 15 (83) to 30 days after the previous treatment.

## CONCLUSION

BT injections are safe and effective for both therapeutic and cosmetic purposes. Facial wrinkles, especially those located in the upper face, and some asymmetries are mainly caused or worsened by the repeated contraction of facial muscles. Acting at the neuromuscular junction, BT injections can alter muscle movements that cause dynamic wrinkles. The knowledge of the anatomy of the facial muscles is important for proper use of BT, allowing physicians to reach predictable results and to avoid complications.

The use of BT is also effective for the treatment of many forms of HH.

BT represents one of the most important advances in minimally invasive techniques for skin rejuvenation, while achieving a high degree of patient satisfaction.

## REFERENCES

1. Carruthers JDA, Carruthers JA. Treatment of glabellar frown lines with C botulinum-A exotoxin. *J Dermatol Surg Oncol* 1992; 18: 17-21.
2. Garcia A, Fulton JE Jr. Cosmetic denervation of the muscles of facial expression with botulinum toxin: a dose-response study. *Dermatol Surg* 1996; 22:39-43.
3. Cather JC, Cather JC, Menter A. Update on botulinum toxin for facial esthetics. *Dermatol Clin* 2002; 20:749-761.
4. Lamanna C. The most poisonous poison. *Science* 1959; 130: 763-772.
5. Rutowitsch M. Toxin structure and drug interactions. In: Hexsel D, Almeida A, eds. *Cosmetic Use of Botulinum Toxin*. Porto Alegre: AGE, 2002:55-57.
6. Lebeda FJ, Hack DC, Gentry MK. Theoretical analyses of the functional regions of the heavy chain of botulinum neurotoxin. In: Jankovic J, Hallet M, eds. *Therapy with Botulinum Toxin*. New York: Marcel Dekker, 1994:51-61.
7. Hexsel D, Hexsel CL, Bohn J. Long, mid, and short term effects of botulinum toxin on the musculature. In: Hexsel D, Almeida AT, eds. *Cosmetic Use of Botulinum Toxin*. Porto Alegre: AGE, 2002: 99-103.
8. Hexsel DM, Almeida AT, Rutowitsch M, et al. Multicenter, double-blind study of the efficacy of injections with BTX-A reconstituted up to six consecutive weeks before application. *Dermatol Surg* 2003; 29:523-529.
9. Hexsel D, Castro IA, Zechmeister D, et al. Multicenter, double-blind study of the efficacy of injections with botulinum toxin a

- reconstituted up to six consecutive weeks before application (letter). *Dermatol Surg* 2004; 30(5):823.
10. Hexsel D, Rutowitsch M, Castro LC, et al. Blind multicenter study of the efficacy and safety of injections of a commercial preparation of botulinum toxin type A reconstituted up to fifteen weeks prior injection. *Dermatol Surg* 2009; 35(6):933–939.
  11. Leslie B, Black L. Botulinum toxin type B (Myobloc). *Dermatol Surg* 2003; 29:496–500.
  12. Karsai S, Raulin C. Current evidence on the unit equivalence of different botulinum neurotoxin A formulations and recommendations for clinical practice in dermatology. *Dermatol Surg* 2009; 35:1–8.
  13. Carruthers JA, Lowe NJ, Menter MA, et al. A multicenter, double-blind, randomized, placebo-controlled study of the efficacy and safety of botulinum toxin type A in the treatment of glabellar lines. *J Am Acad Dermatol* 2002; 46(6):840–849.
  14. Ascher B, Zakine B, Kestemont P, et al. A multicenter, randomized, double-blind, placebo-controlled study of efficacy and safety of 3 doses of botulinum toxin A in the treatment of glabellar lines. *J Am Acad Dermatol* 2004; 51(2):223–233.
  15. Monheit G, Carruthers A, Brandt F, et al. A randomized, double-blind, placebo-controlled study of botulinum toxin type A for the treatment of glabellar lines: determination of optimal dose. *Dermatol Surg* 2007; 33(suppl 1):51–59.
  16. Hexsel D, Dal’Forno T, Hexsel C, et al. A randomized pilot study comparing the action halos of two commercial preparations of botulinum toxin type A. *Dermatol Surg* 2008; 34(1):52–59.
  17. Wollina U, Konrad H. Managing adverse events associated with botulinum toxin type-A: a focus o cosmetic procedures. *Am J Clin Dermatol* 2005; 6(3):141–150.
  18. Sattler G. Patient Management and Treatment Technique. *Clin Dermatol* 2003; 21:485–487.
  19. Salti G, Ghersetich I. Advanced botulinum toxin techniques against wrinkles in the upper face. *Clin Dermatol* 2008; 26(2): 182–191.
  20. Pena MA, Alam M, Yoo SS. Complications with the use of botulinum toxin type A for cosmetic applications and hyperhidrosis. *Semin Cutan Med Surg* 2007; 26(1):29–33.
  21. Carruthers A, Carruthers J. Botulinum toxin type A: history and current cosmetic use in the upper face. *Semin Cutan Med Surg* 2001; 20:71–84.
  22. Hexsel D, Mazzuco R, Rzany B. Other dermatologic indications. In: Ascher B, Landau M, Rossi B, eds. *Injection Treatments in Cosmetic Surgery*. London: Informa Healthcare, 2009:189–196.
  23. Goldman A. Combining procedures with botulinum toxin in plastic surgery. In: Hexsel D, Almeida AT, eds. *Cosmetic Use of Botulinum Toxin*. Porto Alegre: AGE, 2002:216–220.
  24. Ascher B, Talarico S, Cassuto D, et al. International consensus recommendations on the aesthetic usage of botulinum toxin type A (Speywood Unit) - part I: upper facial wrinkles. *J Eur Acad Dermatol Venereol*. 2010 Mar 24.
  25. Ascher B, Talarico S, Cassuto D, et al. International consensus recommendations on the aesthetic usage of botulinum toxin type A (Speywood Unit) - part II: wrinkles on the middle and lower face, neck and chest. *J Eur Acad Dermatol Venereol* 2010 Jun 21.
  26. Carruthers JD, Glogau RG, Blitzer A. Facial Aesthetics Consensus Group Faculty. Advances in facial rejuvenation: botulinum toxin type a, hyaluronic acid dermal fillers, and combination therapies—consensus recommendations. *Plast Reconstr Surg* 2008; 121 (5 suppl):5S–30S.
  27. Hexsel D, Dal’Forno T. Type A botulinum toxin in the upper aspect of the face. *Clin Dermatol* 2003; 21:488–497.
  28. Klein AW. Treatment of wrinkles with Botox<sup>®</sup>. In: Kreyden OP, Böni R, Burg G, eds. *Hyperhidrosis and Botulinum Toxin in Dermatology. Current Problems in Dermatology*. Vol. 30. Basel: Karger, 2002:188–217.
  29. Naoum C, Dasiou-Plakita D. Dermal filler materials and botulin toxin. *Int J Dermatol* 2001; 40:609–621.
  30. Carruthers A, Carruthers J. Cosmetic uses of botulinum A exotoxin. *Adv Dermatol* 1997; 12:325–348.
  31. Marques RMC, Wu SLC. Rare forms of hyperhidrosis. In: Almeida AT, Hexsel D, eds. *Hyperhidrosis and Botulinum Toxin*. São Paulo: Know How Editorial, 2003:47–56.
  32. Sommer B, Lowe N. Cosmetic indications. In: Moore P, Naumann M, eds. *Handbook of Botulinum Toxin Treatment*. 2nd edn. Oxford: Blackwell Science, 2003:422–437.
  33. Wieder JM, Moy RL. Understanding botulinum toxin. Surgical anatomy of the frown, forehead and periocular region. *Dermatol Surg* 1998; 24:1172–1174.
  34. Steiner D. Botulinum toxins: types and subtypes. In: Hexsel DM, Almeida AT, eds. *Cosmetic Use of Botulinum Toxin*. Porto Alegre: AGE, 2002:37–39.
  35. Carruthers A. Botulinum toxin type A: history and current cosmetic use in the upper face. *Dis Mon* 2002; 48:299–322.
  36. Benedetto AV. The cosmetic uses of botulinum toxin type A. *Int J Dermatol* 1999; 38:641–655.
  37. Scott AB, Rosenbaum A, Collins CC. Pharmacological weakening of extraocular muscles. *Invest Ophthalmol* 1973; 12:924–927.
  38. Alster TS, Lupton JR. Botulinum toxin type B for dynamic glabellar rhytides refractory to botulinum toxin type A. *Dermatol Surg* 2003; 29:516–518.
  39. Hexsel D, Mazzuco R, Zechmeister M, et al. Complications and adverse affects: diagnosis and treatment. In: Hexsel D, Almeida AT, eds. *Cosmetic Use of Botulinum Toxin*. Porto Alegre: AGE, 2002:233–239.
  40. Carruthers A, Kiene K, Carruthers J. Botulinum A exotoxin use in clinical dermatology. *J Am Acad Dermatol* 1996; 34:788–797.
  41. Le Louarn C. Botulinum toxin A and facial lines: the variable concentration. *Aesth Plast Surg* 2001; 25:73–84.
  42. Carruthers J, Carruthers A. Botulinum toxin (Botox) chemodeneration for facial rejuvenation. *Facial Plast Surg Clin North Am* 2001; 9:197–204.
  43. Benedetto AV. Asymmetrical smiles corrected by botulinum toxin serotype A. *Dermatol Surg* 2007; 33(1 Spec no.):S32–S36.
  44. Finn JC. Botulinum toxin type A: fine-tuning treatment of facial nerve injury. *J Drugs Dermatol* 2004; 3(2):133–137.
  45. Maio M, Bento RF. Botulinum toxin in facial palsy: an effective treatment for contralateral hyperkinesis. *Plast Reconstr Surg* 2007; 120:917–927.
  46. Carruthers J, Fagien S, Matarasso SL; Botox Consensus Group. Consensus recommendations on the use of botulinum toxin type a in facial aesthetics. *Plast Reconstr Surg* 2004; 114(suppl 6):1–22.
  47. Hexsel D, Mazzuco R, Dal’Forno T, et al. Aplicações nao-classicas. In: Kede MP, Sabatovich O, eds. *Dermatologia Estetica*. Rio de Janeiro: Atheneu, 2003:573–581.
  48. Carruthers J, Carruthers A. Aesthetic botulinum A toxin in the mid and lower face and neck. *Dermatol Surg* 2003; 29(5):468–476.
  49. Carruthers J, Carruthers A. The adjunctive usage of Botulinum toxin. *Dermatol Surg* 1998; 24:1244–1271.
  50. Mazzuco R. Perioral wrinkles. In: Hexsel D, Almeida AT, eds. *Cosmetic Use of Botulinum Toxin*. Porto Alegre: AGE, 2002:158–163.
  51. Kadunc BV, de Almeida ART, Vanti AA, et al. Botulinum toxin A adjunctive use in manual chemoabrasion: controlled long-term study for treatment of upper perioral vertical wrinkles. *Dermatol Surg* 2007; 33:1066–1072.
  52. De Sa Earp AP, Marmur ES. The five D’s of botulinum toxin: doses, dilution, diffusion, duration and dogma. *J Cosmet Laser Ther* 2008; 10:93–102.
  53. Polo M. Botulinum toxin type A (Botox<sup>®</sup>) for the neuromuscular correction of excessive gingival display on smiling (gummy smile). *Am J Orthod Dentofacial Orthop* 2008; 133(2):195–203.
  54. Suryadevara AC. Update on perioral cosmetic enhancement. *Curr Opin Otolaryngol Head Neck Surg* 2008; 16:347–351.
  55. Tartaro G, Rauso R, Santagata M, et al. Lower facial contouring with botulinum toxin type A. *Craniofac Surg* 2008; 19(6):1613–1617.
  56. Yu CC, Chen PK, Chen YR. Botulinum toxin a for lower facial contouring: a prospective study. *Aesthetic Plast Surg* 2007; 31 (5):445–451.

57. Hexsel D, Dal'Forno T. The upper trunk: décolleté wrinkles and breast lift. In: Ascher B, Landau M, Rossi B, eds. *Injection Treatments in Cosmetic Surgery*. London: Informa Healthcare, 2009:153-157.
58. Carruthers J, Carruthers A. Botox use in the mid and lower face and neck. *Semin Cutan Med Surg* 2001; 20:85-92.
59. Becker-Wegerich P, Rauch L, Ruzicka T. Botulinum toxin A in the therapy of mimic facial lines. *Clin Exp Dermatol* 2001; 26(7): 619-630.
60. Ascher B, Rossi B. [Botulinum toxin and wrinkles: few side effects and effective combining procedures with other treatments]. *Ann Chir Plast Esthet* 2004; 49(5):537-552.
61. Bosniak S. Combination therapies: a nonsurgical approach to oculofacial rejuvenation. *Ophthalmol Clin North Am* 2005; 18(2): 215-225.
62. Carruthers J, Carruthers A. A prospective, randomized, parallel group study analyzing the effect of BTX-A (Botox) and nonanimal sourced hyaluronic acid (NASHA, Restylane) in combination compared with NASHA (Restylane) alone in severe glabellar rhytides in adult female subjects: treatment of severe glabellar rhytides with a hyaluronic acid derivative compared with the derivative and BTX-A. *Dermatol Surg* 2003; 29(8):802-809.
63. Semchyshyn NL, Kilmer SL. Does laser inactivate botulinum toxin? *Dermatol Surg* 2005; 31(4):399-404.
64. Landau M. Combination of chemical peelings with botulinum toxin injections and dermal fillers. *J Cosmet Dermatol* 2006; 5(2): 121-126.
65. Lear W, Kessler E, Solish N, et al. An epidemiological study of hyperhidrosis. *Dermatol Surg* 2007; 33(1 Spec no.):S69-S75.
66. Heckmann M, Ceballos Baumann AO, Plewig G. Botulinum toxin A for axillary hyperhidrosis (excessive sweating). *N Engl J Med* 2001; 344:488-493.
67. Hexsel DM, Dal'Forno T, Hexsel CL. Inguinal, or Hexsel's hyperhidrosis. *Clin Dermatol* 2004; 22(1):53-59.
68. Weber A, Heger S, Sinkgraven R, et al. Psychosocial aspects of patients with focal hyperhidrosis. Marked reduction of social phobia, anxiety and depression and increased quality of life after treatment with botulinum toxin A. *Br J Dermatol* 2005; 152(2):342-345.
69. Hexsel D, Rodrigues TC, Soirefmann M, et al. Recommendations for performing and evaluating the results of minor's test according to a sweating intensity visual scale. *Dermatol Surg* 2010;36 (1):120-122.
70. Bahmer FA, Sachse MM. Hyperhidrosis area and severity index. *Dermatol Surg* 2008; 34(12):1744-1745.
71. Haider A, Solish N. Focal hyperhidrosis: diagnosis and management. *CMAJ* 2005; 172(1):69-75.
72. Solish N, Bertucci V, Dansereau A, et al.; Canadian Hyperhidrosis Advisory Committee. A comprehensive approach to the recognition, diagnosis, and severity-based treatment of focal hyperhidrosis: recommendations of the Canadian Hyperhidrosis Advisory Committee. *Dermatol Surg* 2007; 33(8):908-923.
73. Lonsdale-Eccles A, Leonard N, Lawrence C. Axillary hyperhidrosis: eccrine or apocrine? *Clin Exp Dermatol* 2003; 28:2-7.
74. Swartling C, Naver H, Pihl-Lundin I, et al. Sweat gland morphology and periglandular innervation in essential palmar hyperhidrosis before and after treatment with intradermal botulinum toxin. *J Am Acad Dermatol* 2004; 51(5):739-745.
75. Baumann L, Slezinger A, Halem M, et al. Pilot study of the safety and efficacy of Myobloc (botulinum toxin type B) for treatment of axillary hyperhidrosis. *Int J Dermatol* 2005; 44(5):418-424.
76. Baumann L, Slezinger A, Halem M, et al. Double-blind, randomized, placebo-controlled pilot study of the safety and efficacy of Myobloc (botulinum toxin type B) for the treatment of palmar hyperhidrosis. *Dermatol Surg* 2005; 31(3):263-270.
77. Lowe N, Campanati A, Bodokh I, et al. The place of botulinum toxin type A in the treatment of focal hyperhidrosis. *Br J Dermatol* 2004; 151(6):1115-1122.
78. Hexsel DM, Soirefmann M, Rodrigues TC, et al. Increasing the field effects of similar doses of clostridium botulinum type A toxin-hemagglutinin complex in the treatment of compensatory hyperhidrosis. *Arch Dermatol* 2009; 145(7):837-840.
79. Absar MS, Onwudike M. Efficacy of botulinum toxin type A in the treatment of focal axillary hyperhidrosis. *Dermatol Surg* 2008; 34 (6):751-755.
80. Glogau RG. Topically applied botulinum toxin type A for the treatment of primary axillary hyperhidrosis: results of a randomized, blinded, vehicle-controlled study. *Dermatol Surg* 2007; 33(1 Spec no.):S76-S80.
81. Klein AW. Complications with the use of botulinum toxin. *Dermatol Clin* 2004; 22(2):197-205.
82. Matarasso SL. Complications of botulinum A exotoxin or hyperfunctional lines. *Dermatol Surg* 1998; 24:249-254.
83. Hexsel D, Hexsel CL, Dal'Forno T. Complications in the use of botulinum toxin. In: Almeida AT, Hexsel DM, eds. *Hyperhidrosis and Botulinum Toxin*. São Paulo, 2003:227-236.

## Soft tissue augmentation

Emily P. Tierney and C. William Hanke

### INTRODUCTION

As people live longer and healthier lives, more seek physicians to help them maintain and restore a more youthful appearance. A large component of the skin's natural aging process is manifested by volume loss. Contour changes and rhytids occur secondary to atrophy of soft tissues and loss of skin resistance as dermal collagen, hyaluronic acid, and elastin are depleted.

Traditionally, rejuvenation has been achieved with surgical resection of redundant skin, namely through "face lift" or "eye lift" procedures. Today, a multitude of minimally invasive procedures, of which soft tissue augmentation is one, produce significant rejuvenation without the risks, downtime, and expense of major surgery.

Smooth, symmetric facial contour may become disrupted by either natural disease, such as acne, or environmental causes, such as sun exposure, or trauma, or merely by the process of aging. Scars caused by acne or trauma leave depressions of various depths that can be improved using soft tissue fillers. Depressions of an entire cosmetic subunit may be caused by diseases such as HIV lipodystrophy or morphea. Fine rhytids, particularly perioral and periocular lines, can be caused by excessive actinic damage. Normal lines of facial expression become accentuated with age.

Injectable soft tissue augmentation materials available for use in the United States have proliferated during the past five years. In addition to bovine collagen and autologous fat, physicians can now choose between numerous other options, including hyaluronic acid derivatives, poly-L-lactic acid (PLLA), injectable calcium hydroxylapatite (CaHA), polymethylmethacrylate (PMMA) microspheres, and human, bovine and porcine collagen.

This chapter provides an overview of the currently available dermal fillers that are used for augmentation of superficial contour irregularities and subdermal fillers and soft tissue implants that correct contour defects where more volume is needed.

### HISTORICAL ASPECTS

The search for an ideal dermal filler for the correction of facial lines and wrinkles has spanned a century. The first organic injectable filler was injectable paraffin, first used at the turn of the 20th century. This material was significantly complicated by the appearance of paraffinomas and was abandoned (1). Subsequently, in the 1960s, the Dow Corning Corporation (Midland, Michigan, U.S.) introduced a form of liquid silicone (medical grade 360) for the correction of facial deformities, lines, and wrinkles (2). Complications were minimal with the use of the "microdroplet" technique, where silicone was injected in small aliquots through a fine-bore needle. Unfortu-

nately, the lack of uniformity in silicone preparations, with the use of impure and adulterated silicones, resulted in several severe complications (3). These complications, as well as the lack of approval for silicone by the FDA, significantly limited silicone use in the United States.

In the 1970s, research into collagen production led to a bovine formulation that could be placed into a syringe and injected. Injectable bovine collagen was introduced into the market in 1981 by the Collagen Corporation (Palo Alto, California, U.S.) (4–8). Bovine collagen is currently marketed by Inamed Aesthetics (Santa Barbara, California, U.S.) as Zyderm and Zyplast, and is characterized by easy administration, safe, and effective short-term tissue augmentation. Injectable bovine collagen equivalents are also available in Japan (Kokenatelo-collagen implant, Koken Co, KTD, Tokyo) and Europe (Resoplast, Rofil Medical International BV, Breda, The Netherlands), all of which have similar indications to Zyderm and Zyplast collagen. However, the incidence of allergic responses to bovine collagen products and their limited longevity have fueled the continual search for a more ideal dermal filler product (9–11). Human collagens, Cosmoderm and Cosmoplast, have largely replaced treatment with bovine collagen due to the lack of need for skin testing.

A readily available augmentation substance is the patient's own dermis and fat. Early in the 20th century, fat grafts were utilized to fill volume after trauma. However, excising and transplanting fat still represented a major procedure, which in many cases did not have long-lasting effects (12–17). Neuber was the first to report use of autologous tissue for subcutaneous augmentation through the use of dermis and fat (18). Dermis and fat have varying degrees of resorption after implantation, rendering unpredictable outcomes (19). The modern use of fat as a filling substance dates to its reintroduction by Fournier with the "microlipoinjection" technique in the late 1970s (20). The longevity of contour correction after autologous fat injection is highly variable. Duration of correction is dependent on a variety of factors including whether fat is fresh or frozen, viability of fat cells, harvesting and injection techniques, amount of fat injected, location of recipient site, and type of defect treated. Data by Coleman suggest improved duration of correction with autologous fat transfer (21).

In 1957, Spangler first published his studies on the use of "fibrin foam" to treat depressed scars (22). On the basis of this work and modifications by Gottlieb (23), a new product, Fibrel (Mentor Corporation, Santa Barbara, California, U.S.), was developed in 1985. Fibrel is a mixture of epsilon-aminocaproic acid, gelatin powder, and plasma from the patient. The gelatin forms a scaffolding upon which new collagen synthesis occurs. Although venipuncture and centrifugation of the patient's blood made Fibrel preparation tedious, reported results were

generally favorable (24–26). Nonetheless, a corporate decision was made by the Mentor Corporation to discontinue marketing of the product, which at the current time remains unavailable.

The search for an ideal, injectable, soft tissue filler continues. A number of new products have appeared worldwide in the last two decades and new additions to the repertoire of dermal and subdermal fillers continue to grow each year. Many of the currently available injectable filler include biologically compatible agents, such as hyaluronic acid gels (Restylane, Perlane, Juvederm, Hylaform, Puragen), human fibroblasts (Isolagen), fibroblast-derived human collagen (Cosmodern, Cosmoplast), fascia lata (Fascian), acellular human collagen (Alloderm, Cymetra), elastin, and other human dermal products. Others have introduced substances such as Dextran (Reviderm Intra), polyethylene beads (Profill), silicone polymers (Dermagen), polymethylmethacrylate (Artecoll), calcium hydroxylapatite (Radiesse), or poly-L-lactic acid (New-Fill/Sculptra) to increase duration of correction.

Balazs and Denligner established that insoluble, injectable, cross-linked hylan gels derived from hyaluronic acid exhibited a prolonged residence time in soft tissues and were as biocompatible as natural hyaluronan (27). Hylan B, first developed in the mid-1980s, is produced by introducing sulfonylethyl cross-links between hydroxyl groups of the polysaccharide chain of hyaluronan. Hylan B gel has a number of attributes that make it a favorable intradermal injectable implant material. It is water insoluble, resists degradation, and unlikely to migrate. The high water content mimics the natural hydrating function of native hyaluronan in the skin. The physical properties of hyaluronic acid gels are controlled by the molecular weight and the concentration of the material and by the degree of cross-linking (28). The most commonly used sources of hyaluronic acid are rooster combs (Hylaform), bacterial cultures (Restylane, Juvederm), as well as human umbilical cord, vitreous humor, tendons, and skin (29).

PMMA was first synthesized in 1902 by the German chemist Rohm and was patented as Plexiglass in 1928. It has had medical applications since 1945, commonly used in bone cement, intraocular lenses, dental prostheses, and repair material for craniofacial surgery. In addition to being biocompatible and immunologically inert, PMMA has never demonstrated degradation or carcinogenicity (30,31). The initial product tested, Arteplast, was heterogeneous, containing various PMMA monomers, spheres of various sizes and even some impurities. It led to several cases of granuloma formation, with swelling and inflammation. Artecoll (formerly ArteFill), which has been available in Europe for a decade, contains only smooth microspheres of 30 to 40  $\mu\text{m}$  in size, and 99% of the remaining monomers have been removed during processing. These changes in the product size and uniformity of particle composition have resulted in a significantly decreased incidence of granuloma formation (32).

In 1971, Robert and William Gore developed expanded polytetrafluoroethylene (e-PTFE) as an expanded fibrillated form of Teflon (PTFE). Teflon was first used as a vascular prosthesis in bypass surgery (33–43) but rapidly found uses in a variety of other surgical procedures, such as the treatment of facial lines and wrinkles and lip augmentation. It was approved for use in facial and reconstructive surgery in 1993. Advanta (Atrium Medical Corporation, Hudson, New Hampshire, U.S.) is one of the newer versions of these products. It is a dual-porosity e-PTFE that is marketed as a softer, smoother implant that comes in a larger diversity of shapes and sizes. It became

available in 2001, with studies by Hanke (44) demonstrating encouraging results in the treatment of marionette lines (the vertical grooves extending downward from the oral commissures to the mental area), nasolabial folds, and lip augmentation.

Alloderm (LifeCell Corporation, Palo Alto, California, U.S.) is acellular human cadaveric dermis, which has been freeze-dried. It is processed as sheets and has been widely used in the treatment of full-thickness burns, blistering conditions such as epidermolysis bullosa, and in reconstructive surgery for patients with urinary incontinence. It is also used as an implant in soft tissue augmentation procedures such as rhinoplasty, lip augmentation, glabellar contouring, and scar revision (45,46). Cymetra (LifeCell Corporation) is the injectable form of Alloderm. Both Cymetra and Alloderm have been available since the mid-1990s.

Most recently, two novel filling substances, Radiesse and Sculptra, which are considered stimulatory fillers, have been introduced into the filler market. These two fillers are considered “stimulatory fillers” as they induce a fibroblastic response that results in the formation of new collagen and connective tissue. This allows the clinical effects to last for a prolonged duration, which has been reported to range from 12 to 36 months. Radiesse (Bioform, Franksville, Wisconsin, U.S.) is composed of CaHA microspheres suspended in polysaccharide gel. It has been utilized as a soft tissue filler for augmentation of the nasolabial folds, zygomatic region, lips, under-eye region, and as a nonsurgical rhinoplasty treatment to improve nasal contouring. Poly-L-lactic acid (PLLA, Sculptra, Dermik, Bridge-Water, New Jersey) was initially approved by the FDA for the correction of facial lipoatrophy in patients with HIV infection. PLLA was approved for nasolabial folds in non-HIV patients in 2009. It was utilized for the correction of fine lines, wrinkles, folds, and creases, as well as for augmentation, repositioning, and contouring of the cheeks, chin, and lips. The PLLA micro-particles are absorbed slowly over a period of several weeks after injection, but the newly generated collagen and clinical effects last for at least 18 to 24 months.

## INDICATIONS

Fillers either replete defects or augment existing facial structures. Beginning with the upper third of the face, fillers can be used to fill in depressions in the forehead from acne scars. Temporal depression that is associated with age may also be augmented, and lines of expression such as glabellar frown lines can be diminished. Filling the upper third of the face is potentially more challenging because of the concurrence of dynamic creases in this region. In the periorbital region, fillers may be used for “etched-in” crow’s feet, with some practitioners advocating using fillers in the lateral eyelid as a substitute for surgical brow lift. In the lower eyelid, restoring this subunit’s volume rather than removing fat has become a guiding principle in restoration of the upper face. The appropriate use of a filler can remove the “double bubble” between the lower eyelid and the upper cheek as well as camouflage the nasojugal groove.

In the midface, fillers can be used to correct traumatic or acne scars. The types of acne scars most amenable to treatment are either atrophic or rolling scars. Sinking and effacement of the malar eminence and hollowing of the cheeks can also be corrected with fillers. While the malar region can be directly built up, often merely adding volume diffusely to the cheeks

will increase the malar prominence. Cheek hollowing is commonly treated with fillers in patients with HIV lipoatrophy. While the thinness of nasal skin may lead to a higher rate of complications or unsatisfactory results with the use of fillers, experienced practitioners can effectively fill scars and alter the profile of the nasal dorsum.

The most popular anatomic areas for injectable soft tissue augmentation, and the ones with the most prolonged results, are the nasolabial folds and the marionette lines, also known as "smile" lines. Deepening of the nasolabial folds, which are in the transition zone between the midface and lower face, creates an abnormal demarcation between these two major facial regions. The desire of even young patients to fill these lines reflects the aesthetic aspiration for a smooth facial contour. A secondary effect of filling these lines is to increase the profile prominence of the medial cheeks.

The lower face is dominated by the lips. Fine vertical rhytids of the upper lip can be diminished with judicious use of fillers. Age-related effacement of both the upper and the lower lip margins, as well as thinning of the lips, can also be corrected. Many types of fillers can be used in the lips to achieve a natural fullness, and other fillers can be used to redefine the effaced vermilion border. Marionette or "drool" lines are a combination of expression, aging, and genetics. While a variety of fillers can be used to reduce them, in older individuals or those with advanced actinic damage and sagging, filling them may create ripples lateral to the injection area.

A sign of aging in the lower face is unevenness of the jawline. This is caused not only by loss of skin elasticity and gravity but also because of resorption of the mandible. Selective injection of the appropriate filler can create a smooth and robust mandibular line. Although permanent implants are the procedure of choice for increasing chin projection, using fillers can temporarily create a prominence at this point. Use of fillers for this indication may also be useful in allowing the patient to determine if he or she desires a permanent implant.

## TECHNICAL ASPECTS AND OVERVIEW OF COMMONLY USED PRODUCTS

### Bovine Collagen

Bovine collagen was the first device approved in 1981 for soft tissue augmentation in the United States (47). Since this time, over 1 million patients have been treated. The results typically last for three to four months. The desire for a longer duration of correction has led to a decrease in the use of collagen injections as a dermal filler substance. The material is derived from the isolated hides of domestic cattle (48).

Given the 1% to 3% risk of hypersensitivity, bovine collagen requires pretesting for hypersensitivity reactions. Internal postmarketing surveillance by Inamed showed a 3% prevalence of circulating antibodies to bovine collagen. Two skin tests, performed at two to four weeks, are the standard assessment recommended (49,50). Positive skin test is defined as erythema, induration, tenderness, or swelling that persists more than six hours after implantation, and typically arises two to three days after implantation as a delayed hypersensitivity reaction. Patients are typically very upset in the event of a hypersensitivity reaction. Therefore, skin testing and waiting the entire duration of follow-up prior to injection are imperative prior to treatment. Treatments for hypersensitivity reactions include intralesional steroids, topical tacrolimus 0.1% ointment b.i.d., systemic steroids, or systemic cyclosporine (51,52).

Contraindications to injectable bovine collagen include anaphylactic event of any cause, prior hypersensitivity to bovine collagen, lidocaine sensitivity, pregnancy or lactation, and any signs of infection at the injection site.

Zyderm I consists of 3.5% bovine collagen suspended in sodium chloride with 0.3% lidocaine. It contains 95% to 98% type I collagen and 2% to 5% type III collagen. It is designed to be injected into papillary dermis for superficial rhytids and is useful around eyes, lips, glabellar region, and cheek.

Zyderm II consists of 6.5% bovine collagen suspended in sodium chloride with 0.3% lidocaine and is slightly more viscous than Zyderm I. It is injected deeper than Zyderm I (into upper reticular dermis) for the treatment of more coarse rhytids as well as for acne scarring and lip augmentation.

Zyplast, like Zyderm I, is composed of 3.5% bovine collagen suspended in sodium chloride with 0.3% lidocaine. Zyplast is cross-linked with glutaraldehyde to form a latticework and a more viscous compound. It is less immunogenic than either Zyderm I or II and is more resistant to degradation. Zyplast is injected into the mid to deep reticular dermis for treatment of deeper rhytids and contour defects, including marionette lines and significant volume lip augmentation.

### Human Collagen

Cosmoplast and Cosmoderm are human-derived collagen products from long-standing fibroblast culture lines. They are similar to bovine collagen in injection technique; however, the significant advantage of human collagen includes the lack of antigenicity that makes skin pretesting unnecessary. Cosmoplast and Cosmoderm contain lidocaine that decreases discomfort associated with injection.

For the injection of Cosmoplast and Cosmoderm, the skin should be held taut by the free hand with the patient's head supported by back/neck rest. The needle should be angled parallel to the skin for superficial lines and wrinkles with a gradually greater angle for deeper lines and grooves. Serial punctures are generally made, along or adjacent to the wrinkle being treated, with small aliquots of material injected through each puncture site. Gentle massage can mold the collagen at the treatment site to ensure the final result is even and smooth. For deeper rhytids, the needle may be placed perpendicular to the skin surface. Care must be taken to ensure placement at the base of the furrow rather than at the shoulder of overhanging redundant skin. With the threading technique, a longer needle may be used and advanced for some distance under the rhytid with injection as the needle is withdrawn. Threading is utilized more routinely with hyaluronic gels as well as more viscous products, including Zyplast and Cosmoplast.

Injections at the medial side of the nasolabial fold and marionette lines should be performed to avoid further heaviness laterally. Crow's feet should be approached with caution to avoid overfilling and lumpiness. The orbital area is highly prone to bruising. Local pressure prior to injecting will help prevent bruising.

### Hyaluronic Acid

Hyaluronic acid (hyaluronan) is a naturally occurring glycosaminoglycan biopolymer, which is a component of all connective tissues. It exhibits no species or tissue specificity because the chemical structure of the polysaccharide is uniform throughout nature. Therefore, there is no potential for immunologic reactions to hyaluronan in humans. In nature, the primary biologic

function of hyaluronan is to provide stabilization to the intercellular structures and to form the elastoviscous fluid matrix in which collagen and elastic fibers become embedded (53). In addition, the hyaluronan matrix regulates cell movement and functions, and plays a role in developing and remodeling tissues (54). Hyaluronan has a very large average molecular weight (4–5 million Da in all human tissues) and consists of repeating disaccharides of D-glucuronic acid and N-acetyl-D-glucosamine arranged in long, unbranched polyanionic chains (53–56,30). These molecular chains form highly hydrated random coils that entangle and interpenetrate each other, producing highly elastoviscous solutions (53–56,30).

The amount of hyaluronic acid in the skin progressively decreases with age (55), and results in reduced dermal hydration and increased skin folding (56). With its unique elastoviscosity, immunologic compatibility, and natural role as a structure-stabilizing, space-occupying, cell-protecting connective tissue matrix filler, hyaluronan would at first sight appear to be an ideal material for soft tissue augmentation (30). However, with a tissue half-life of only one to two days, hyaluronan turns over too quickly to be of value in this regard (57). Exogenous hyaluronic acid is rapidly cleared from the dermis and degraded in the liver to carbon dioxide and water. For this reason, investigators sought modifications of hyaluronan that would render it more stable following injection while preserving its properties of biocompatibility.

Stabilized hyaluronic acid gel fillers, first evaluated in 1998, provide good efficacy with a considerably longer duration of action than the first generation of dermal fillers, namely, bovine and human collagen. The first injectable stabilized hyaluronic acid filler approved by the U.S. Food and Drug Administration, a non-animal-stabilized hyaluronic acid (NASHA) 100,000 gel particles/mL filler, was introduced in the United States in 2003 and has been shown to be safe and effective while providing a much longer duration of action than that of collagen fillers. The use of hyaluronic acid gel fillers has increased considerably since that time. They are currently the most commonly used injectable fillers by a wide margin. According to the American Society for Aesthetic Plastic Surgery, hyaluronic acid gels accounted for approximately 80% of the nearly 2 million soft tissue filler injections performed in 2006.

The prolonged efficacy of stabilized hyaluronic acid gel fillers is attributed to the cross-linking between hyaluronic acid polymers and to the gradual absorption of water as the filler degrades. Some data suggest that stabilized hyaluronic gels stimulate collagen synthesis and inhibit collagen breakdown, which may contribute to their effectiveness and long duration of action (53–56,30,57–66).

#### *Injection Technique*

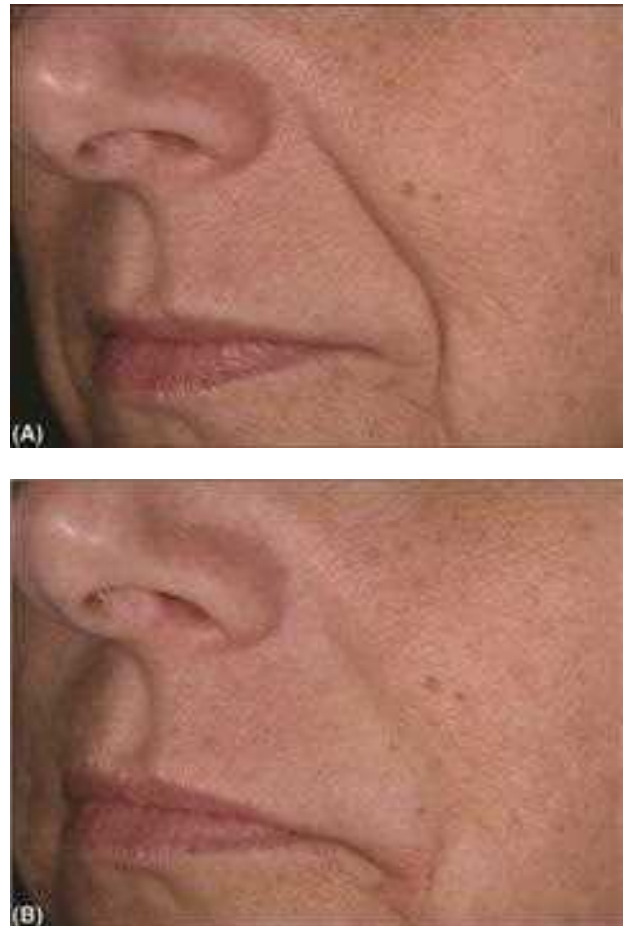
In general, hyaluronic acid products are injected into the dermis or close to the dermal-subcutaneous junction (66–69). Injections high in the skin, near the interface of the epidermis and papillary dermis, are usually avoided as superficial injection technique can result in visible white, yellow, or blue nodules, which may be persistent. Injections deep into the subcutaneous fat may result in decreased efficacy of correction with the subsequent need for larger volume injections.

One injection technique for hyaluronic acid is the linear threading technique (70–73). Injections are administered using a threading technique with the needle advanced along the line to be treated with constant pressure on the syringe plunger as

the needle is withdrawn and advanced. Successive threads of injected material are placed adjacent to previous injections until the entire fold has been treated. After injection, massage of the product, along the line of injection, can be performed to ensure that the implant is smooth and uniform.

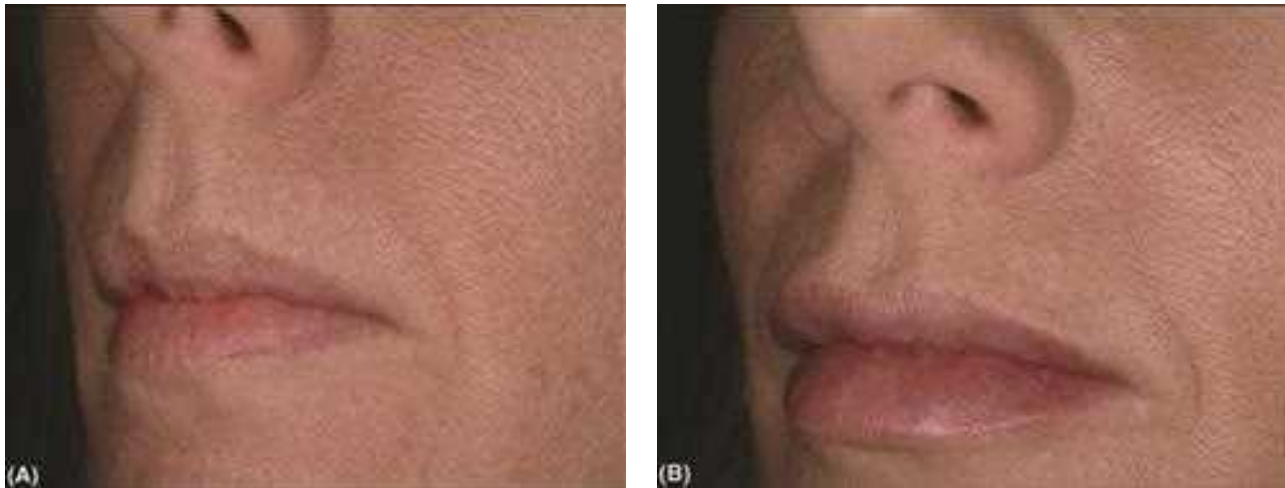
For lip enhancement, the technique should include first defining the lip margin by gently injecting along the vermilion border (74–76). A row of successive aliquots of hyaluronic acid should be administered in five to six threads for the lip margin (total volume of 0.3 to 0.4 mL should be used for lip definition). The remainder is injected, with the threading technique, along the wet line of the red lip (the line at which the dry outer mucosa meets the moist inner mucosa). Spreading is noted as the hyaluronic acid spreads through the plane of injection. Gentle massage should be performed throughout the treatment to ensure uniformity and smoothness of the correction.

For treatment with hyaluronic acid products under the eyes and in the glabellar space, injections should be performed slowly, with limited injectant, to avoid intravascular injection that can result in vascular occlusion as well as bruising (77,78). Significant edema can occur for several days after injection, and patients should be apprised of this prior to injection (see further, Figs. 52.1–52.3).



**Figure 52.1** (A,B) Pre- and post-hyaluronic acid injections for nasolabial folds and marionette lines in a 60-year-old woman.





**Figure 52.2** (A,B) Pre- and post-hyaluronic acid injections for upper and lower lip volume loss in a 50-year-old woman.



**Figure 52.3** (A,B) Pre- and post-hyaluronic acid injections for lower eyelid tear trough in a 40-year-old woman.

### Calcium Hydroxylapatite

Radiesse is composed of CaHA microspheres suspended in a polysaccharide carrier that holds the microspheres in place until resorbed and fibroblast-driven collagenesis takes place (79–88). Injectable CaHA consists of a 30% concentration of 25- to 45- $\mu\text{m}$  CaHA spherical particles suspended in a sodium carboxymethylcellulose gel (79–88). CaHA microspheres remain in place to act as a scaffold that promotes soft tissue ingrowth. Fibroblasts lay down a collagenous extracellular matrix (79–88). As the matrix is deposited, the implant becomes integrated into the surrounding soft tissue, which provides for its long-lasting effects (79–88). Implant palpability diminishes over time as CaHA is integrated into the surrounding soft tissue (79–88). It is FDA approved for two facial soft tissue augmentation indications: treatment of moderate-to-severe facial lines and folds, such as nasolabial folds, and for correction of facial soft tissue loss resulting from HIV-related lipodystrophy (79–88).

In previous studies of soft tissue augmentation in facial applications, Radiesse has been demonstrated to last up to a year or more in most patients (79–88). Collagen proliferation combined with the slow breakdown of the CaHA is believed to account for the prolonged effects observed when CaHA is utilized for soft tissue augmentation (81).

The CaHA used in Radiesse is synthetic in origin. It is inherently biocompatible because it is identical in composition to bone mineral. Radiesse has been demonstrated to be non-obstructive in X rays, and when placed in soft tissue has not demonstrated any heterotopic bone growth (79–88). In 2006, Radiesse gained FDA approval for use in facial aesthetics and in treating facial lipodystrophy associated with HIV (82). CaHA is radiopaque when injected as a bolus, but when utilized for soft tissue augmentation, the material is spread throughout the targeted area, making the material invisible on routine X rays (82). It can, however, be easily detected on MRI scans (82). Longevity of correction with CaHA is attributed to slow rate of

dissolution, rapid rate of soft tissue ingrowth, and slow rate of particle dislocation (82).

#### *Injection Technique*

Injectable CaHA is approved for correction of mild-to-moderate facial rhytids and for correction of facial wasting associated with HIV lipodystrophy. Additional off-label indications include correction of marionette lines and oral commissure, prejowl sulcus, cheek volume loss, and dorsal nasal deformities.

It may also be injected into the glabellar fold, but with caution since there may be an increased risk of tissue necrosis, given the viscosity of the material. It may also be injected into the lips; however, there have been reports of lumpiness and nodularity, and possibly granulomas, following injection into the lips.

For injection of malar and zygomatic regions, a 27-gauge 1.25-in. needle is utilized. Multiple linear threads are placed three-dimensionally in a double-fanning motion across the malar eminence. Crosshatching of material in multiple planes and depths is essential to provide optimal structural support. Target layers can be subdermis, subcutaneous, or periosteal. Multiple strands of the product are extended laterally across the zygoma, using the fanning technique, to accentuate its natural prominence. To avoid clumping of the material by the orbicularis oculi muscle, deposition of the material should not extend above the inferior orbital rim. Small volumes of CaHA are required during each thread deposition (0.05 mL per pass). Following injection, the implanted material can be easily massaged and molded to provide the desired end result and eliminate any possible palpable filler material. Typical volumes required for facial contouring of the malar and zygomatic regions range from 0.7 to 1.0 mL per malar area.

For injection technique of the nasolabial folds, a fanning technique is utilized starting medially to the nasolabial fold with a depth of injection in the subdermal plane. The entry point is placed at the lowest point of the straight component of the nasolabial fold.

### **Porcine Collagen Cross-Linked with Glymatrix Technology**

Dermicol-P35 (Evolence, Ortho Dermatologics, Los Angeles, California, U.S.) is a highly purified form of porcine type I collagen, which is a preferred medical grafting substance due to its nearly identical similarity to human collagen (89). The unique feature of Evolence is the cross-link with natural D-ribose (Glymatrix technology) rather than glutaraldehyde or butanediol diglycidyl ether (BDDE), which renders the product significantly less antigenic and obviates the need for skin test prior to treatment (89). Evolence is designed to be injected deeper into the dermis where it forms a 3D cellular matrix, replacing the skin's depleted collagen with new collagen (89). It is designed for correction of moderate to deep facial wrinkles, such as nasolabial folds and marionette lines (89). Evolence was officially taken off the U.S. market on November 3, 2009.

### **Poly-L-Lactic Acid**

Sculptra (PLLA) is a stimulatory filler designed to be injected into the deep dermis or dermal-subcutaneous junction to treat lipodystrophy of the face and hands, HIV lipodystrophy (only current FDA approved indication), liposuction contour deformities, and atrophic lips (Figs. 52.4A and 52.5B) (90–98). It is a non-animal-derived PLLA that is biocompatible, biodegradable, and immunologically inert. PLLA is distributed freeze-dried and can be stored at room temperature, and is reconsti-

tuted 24 hours prior to injection in sterile water. Importantly, it is not intended for direct injection of rhytids (it is too bulky to be injected superficially), rather, it is intended to recontour the face, causing a 3D augmentation that serves to lift the face and stretch rhytids and soft tissue redundancies.

PLLA is a sterile freeze-dried preparation composed of 24.5% sodium carboxymethylcellulose (an emulsifying agent), 34.7% nonpyrogenic mannitol (promotes osmosity), and 40.8% PLLA microparticles (90–98). Injection of PLLA into the subcutis results in subcutaneous volume restoration. The postulated mechanism of action includes a foreign body tissue response, leading to an increase in fibroblasts and subsequent neocollagenesis.

PLLA gained FDA approval in 2004 for the treatment of HIV lipodystrophy (90–98). In 2009, PLLA gained FDA approval for correction of nasolabial folds. Patients should be advised that between three and six treatment sessions will likely be required, with a definable photographic difference occurring between two and three treatments. Although the precise duration of volumetric correction is unknown, results seen after injection with PLLA have been demonstrated to last for up to two and three years. Gradual resorption is thought to occur over a two- and three-year period with eventual breakdown of the material to lactic acid, found naturally in the body.

#### *Injection Technique*

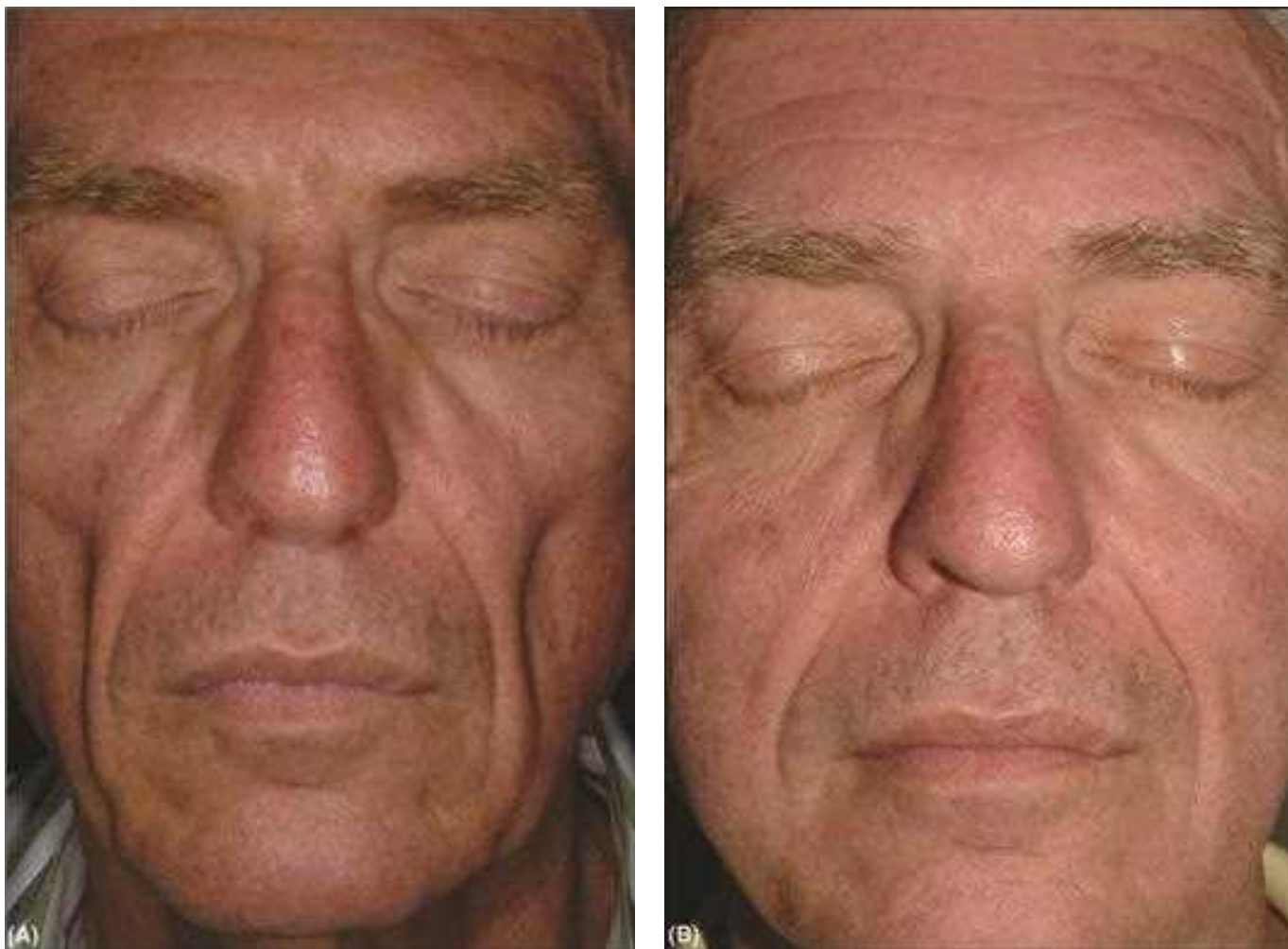
The appropriate reconstitution of the material and continuous mixing is essential for obtaining optimal results with PLLA injections. The material should be reconstituted with at least 3 to 5 mL of sterile water on the night before the procedure (93,94). On the day of the procedure, an additional 2 to 4 mL of 1% lidocaine is added for a total of 5 to 9 mL dilution (90–98). The material is drawn into a 3-mL syringe with an 18-gauge needle that is then changed to a 25-gauge 1/4-in. needle for injection (90–98).

Prior to injection, the material is vigorously shaken (preferably with the use of a vortex device) to obtain a uniform translucent suspension (93,94). This should be done immediately prior to injection and at any point during the procedure when the product appears to have settled out of suspension (93,94).

The physician's nondominant hand is utilized to stretch the skin, avoiding hand positioning in target of the advancing needle (93,94). The suspension is injected into the outlined areas using several of the predrawn dots as injection points (93,94). The needle is advanced in even fan-like sweeps in the upper subcutaneous fat layer just below the dermal-subcutaneous junction (93,94). The material should be injected as evenly as possible during needle withdrawal (93,94). Movements should be fluid and expeditious with constant motion until injection is complete to minimize needle blockage of uneven material dispersion (93,94). Of the six to eight marked anesthesia injection sites, only three to four need to be utilized for the injection of PLLA (93,94). As injection of PLLA into the dermis can result in dermal nodules, injection should cease prior to pulling the needle upward from the dermal-subcutaneous junction in the mid to superficial dermis (93,94). Focal blanching and outpouching of the skin may be a sign that injection is too superficial and should be followed by firm focal massage if observed (93,94).

Treatment is followed by 10 minutes of firm massage to the treated areas to ensure a smooth and natural appearing correction (93,94).

On average, a patient with moderate-to-severe HIV lipodystrophy will require approximately one vial of PLLA



**Figure 52.4** (A,B) Pre- and posttreatment with PLLA injections for HIV lipoatrophy of the malar areas in a 60-year-old man.

injected to each cheek per injection session; however, treatment volumes vary significantly from patient to patient. A patient with minimal subcutaneous loss due to lipoatrophy of aging may only require one half vial to each side. A total of three to six treatment sessions are typically required for patients with both HIV lipoatrophy and lipoatrophy of aging to achieve full correction (see further, Figs. 52.4 and 52.5).

### Polymethylmethacrylate

Injectable PMMA is composed of a suspension of 20% non-resorbable PMMA and 80% bovine collagen (99–101). PMMA is a chemically inert and biocompatible synthetic implant material widely used in bone implants, intraocular lenses, and dental implants. In the prepackaged injectable filler, PMMA is present as 30- to 50- $\mu\text{m}$  spherical particles. The injectable filler consists of 20% by volume PMMA microspheres suspended in a water-based carrier gel composed of partially denatured 3.5% bovine collagen, 92.6% buffered, isotonic water for injection, 0.3% lidocaine hydrochloride, 2.7% phosphate buffer, and 0.9% sodium chloride. The bovine collagen

source is from an isolated, U.S.-bred calf herd monitored according to both FDA and USDA guidelines. Injectable PMMA implants are provided in syringes containing 0.8- and 0.4-mL fill volumes. Skin tests of the bovine collagen gel only are provided in syringes containing a 0.3-mL fill volume for allergy prescreening.

After injection, the collagen carrier is degraded by the body within one to three months, and then new collagen is deposited by the host to encapsulate and engulf the remaining scaffold of PMMA particles (99–101). The PMMA microspheres are nonbiodegradable and too large for macrophage phagocytosis. The in vivo persistence of PMMA particles is extremely long lasting to permanent.

Injectable PMMA is FDA approved for the correction of nasolabial folds (99–101). Other off-label indications for this material are deep facial wrinkles at other sites on the face, as well as other soft tissue contour deficiencies or deformities. Injectable PMMA is most appropriate for patients with well-defined deeper facial wrinkle lines and little excess skin laxity. Patients with sebaceous skin and large pore size, or those with



**Figure 52.5** (A,B) Pre- and post-poly-L-lactic acid injections to the malar areas in a 59-year-old woman with non-HIV lipoatrophy.

extremely thin and loose skin, are poor candidates, in whom the implant may be palpable, result in a shiny skin appearance, or even be directly visible after placement.

In October 2006, the FDA approved injectable PMMA (ArteFill) for the correction of nasolabial folds in men and women (99–101). The efficacy and safety evaluation period in the data submitted for FDA evaluation was 12 months. Further data on longer-term efficacy and safety were submitted to the FDA in March 2007.

#### *Adverse Events with PMMA*

The most common short-term side effects include injection-related bleeding, bruising, erythema, and edema (99–101). Because of its long-lasting effect, PMMA is less forgiving of faulty technique than other injectable fillers. If gaps are apparent in the initial correction, such uneven distribution may be correctable by subsequent injections into the gaps. Excessively deep injection results in ineffective treatment, and further treatments may be required to create adequate correction. Implantation done too superficially may cause, in addition to visible disfig-

urement, pruritis and erythema, which can be treated with topical corticosteroids or intradermal corticosteroid injections.

Papules and areas of excessive fullness due to incorrectly placed or excess injectant, as well as true granulomas, have been reported (99–101). Both of these may respond well to injection of triamcinolone acetonide (20 mg/mL). The corticosteroid should be injected with care to avoid atrophy and to ensure that only the locus of PMMA is targeted. It is reportedly prudent to administer very small amounts of low concentration triamcinolone acetonide (e.g., 0.05–0.1 mL per treatment session of 10 mg/mL triamcinolone acetonide) directly into the area of excess fullness or inflammation. Use of a small syringe and fine needle (e.g., a BD-II 0.3-mL syringe with a swaged-on 31-gauge needle) can provide maximal control of injection rate and minimal discomfort to the patient. Treatment can be repeated every three to four weeks until the desired result is achieved.

Areas of undesired fullness due to excess injectant or due to treatment sessions more frequent than every 8 to 16 weeks are especially common in the lips, and for this reason treatment of the lips is a contraindication (99–101).

Granulomas have been described with Artecoll more so than ArteFill (99–101). Because of the reduction in the number of small particles in ArteFill, it is hypothesized that granulomas will be less frequent with ArteFill than with Artecoll. Granulomas show a characteristic clinical appearance. They typically occur a number of years after Artecoll injection, sometimes associated with a procedure, affect all the treated areas eventually, and have a hard texture and bluish appearance if superficial. Sometimes they respond well to intralesional triamcinolone acetonide, but at other times they are very persistent and resistant to therapy. The possible occurrence of this complication is the main potential drawback to therapy with ArteFill. It is wise to obtain a biopsy in all cases where a granuloma is suspected, to confirm the diagnosis and to determine whether the granuloma, if present, is related to ArteFill or to another filler (e.g., silicone) or to another cause, that is, injection. The pathology report will also help to guide the most appropriate treatment.

#### *Injection Technique*

The FDA currently requires a skin test prior to PMMA. Four weeks prior to treatment, the patient should receive a 0.1-mL intradermal injection of collagen into the volar forearm to determine sensitivity to the treatment material. The patient should observe the test site daily in the four-week test period and notify the physician immediately if any possible positive or equivocal responses occur. A positive response consists of erythema of any degree, induration, tenderness, and swelling, with or without pruritus. Patients developing a positive response should not be treated. An equivocal response is one in which there is no localized skin reaction, but the patient does develop a possible systemic reaction such as rash, arthralgia, or myalgias that occurs at any time during the four-week observation period. If an equivocal response is observed, a second injection in the opposite arm is required. Patients demonstrating a positive or equivocal response in the second test should not be treated.

Since injectable PMMA contains 0.3% lidocaine, treatment without additional anesthesia is possible. However, topical anesthesia or an infraorbital local anesthetic block can be applied prior to treatment.

Injectable PMMA is supplied in 0.8- and 0.4-mL syringes. A 26-gauge 5/8-in. needle is recommended for use. A 25-gauge 1-in. needle may be substituted as the extra length enables a smaller number of needle insertions. The syringe must be brought to room temperature prior to injection. Prior to injection, a small amount of material should be extruded from the tip to ensure that there is no blockage. Postoperative ice packs may be used.

PMMA is injected into the dermal-subcutaneous junction utilizing the “tunneling” or “linear threading” technique. Depending on the thickness of the skin and depth of the fold receiving correction, the needle is inserted at a 20° to 40° angle beneath the wrinkle. Proper needle placement will result in the needle outline being visible. If the needle is placed too superficially, the needle will be visible and blanching will be observed on injection. In this event, injection should then immediately cease and proper placement reestablished. If any product was inadvertently injected, it should be massaged out of the tract. If the needle is placed too deep, a pop will be felt as the subcutaneous tissue is entered and the needle outline is no longer visible. Injection into the subcutaneous tissue results in loss of injectant and hence minimal correction. If in doubt, it is

preferable to inject more deeply than superficially as the risk of wasted PMMA is less problematic than that of superficial injection resulting in long-term skin surface texture or color abnormalities.

Upon confirmation of correct needle placement, injection of material should proceed in a retrograde fashion, with application of constant even pressure on the plunger to ensure uniform placement. The viscosity of PMMA is three times higher than that of collagen, so a higher pressure is needed. Also, resistance to injection will be felt with appropriate placement in the dermis. In contrast, if the needle is too deep (in the subcutaneous tissue) there will be less resistance. Injection should proceed slowly and evenly and cease before withdrawal of the needle from the skin. This technique is then repeated along the defect to be corrected to produce a series of injection tracks that correct the depressed nasolabial fold. After injection, the area should be massaged to uniform surface contour. Any palpable lumps should be massaged gently until smooth.

Patient evaluation is recommended after four to six weeks to assess the need for further additional treatments. The risk of creating areas of excess fullness can be minimized by avoiding overcorrection during each treatment session and by waiting between 8 and 16 weeks between treatment sessions. Optimal correction usually requires two to three treatments. Recently submitted U.S. data indicate that nasolabial fold correction after injection of PMMA remains for at least five years. Reports from Europe and Canada suggest longevity of correction of over 10 years.

## SUMMARY

Since the introduction of injectable bovine collagen in 1981, injectable fillers and soft tissue implants have become an integral part of dermatologic surgery. Proven safety and efficacy of these products have encouraged a large number of biotechnology companies to invest in the development of more “ideal” filler materials. Patient demand and the number of dermatologists performing injections have helped to stimulate the development of a diverse array of fillers. Physicians need to be aware of the differences in particle size, viscosity, placement depth, and duration of correction of the diverse array of available dermal and subcutaneous fillers. Subcutaneous fillers, PLLA and CaHA, represent a considerable advance in filler technology, allowing both correction of deeper fold and rhytids as well as augmentation of volume lost in lipoatrophy associated with HIV and photoaging. Continued development of novel filling substances and novel indications for use will occur in the next decade, making this one of the most exciting areas of growth in the field of aesthetics and dermatologic surgery.

## REFERENCES

1. Heidingsfeld ML. Histo-pathology of paraffin prosthesis. *J Cutan Disease* 1906; 24:513–521.
2. Ashley FL, Braley S, Reed TD, et al. The present status of silicone fluid in soft-tissue augmentation. *Plast Reconstr Surg* 1967; 39: 411–420.
3. Duffy D. Injectable liquid silicone: new perspectives. In: Klein AW, ed. *Tissue Augmentation in Clinical Practice: Procedures and Techniques*. New York: Marcel Dekker, 1998:237–267.
4. Benedetto AV, Lewis AT. Injecting 1000 centistoke liquid silicone with ease and precision. *Dermatol Surg* 2003; 29:211–214.
5. Klein AW. Implantation techniques for injectable collagen. Two and one half years of personal clinical experience. *J Am Acad Dermatol* 1983; 9:224–228.

6. Kaplan EN, Falces E, Tolleth H. Clinical utilization of injectable collagen. *Ann Plast Surg* 1983; 10:437-451.
7. Tromovitch TA, Stegman SJ, Glogau RJ. Zyderm collagen: implant techniques. *J Am Acad Dermatol* 1984; 10:237-278.
8. Castrow FFII, Krull EA. Injectable collagen implant-update. *J Am Acad Dermatol* 1983; 9:889-893.
9. Clark DP, Hanke CW, Swanson NA. Dermal implants: safety of products injected for soft-tissue augmentation. *J Am Acad Dermatol* 1989; 21:992-998.
10. Siegle RJ, McCoy JP Jr., Schade W, et al. Intradermal implantation of bovine collagen: humoral responses associated with clinical reaction. *Arch Dermatol* 1984; 120:183-187.
11. Keefe J, Wauk L, Chu S, et al. Clinical use of injectable bovine collagen: a decade of experience. *Clin Mater* 1992; 9:155-162.
12. Thompson N. Tissue transplantation. In: Grabb W, Smith J, eds. *Plastic Surgery*. Boston: Little, Brown, 1973:106-130.
13. Sattler G, Sommer B. Liporecycling: a technique for facial rejuvenation and body contouring. *Dermatol Surg* 2000; 12:1140-1144.
14. Coleman SR. Structural fat grafts: the ideal filler? *Clin Plast Surg* 2001; 28:111-119.
15. Coleman WP III, Lawrence N, Sherman RN, et al. Autologous collagen? Lipocytic dermal augmentation. A histopathologic study. *J Dermatol Surg Oncol* 1993; 19:1032-1040.
16. Schlafani AP, Romo T III. Collagen, human collagen and fat: the search for a three-dimensional soft tissue filler. *Facial Plast Surg* 2001; 17:79-85.
17. Swinehart JM. Dermal grafting. *Dermatol Clin* 2001; 19:509-522.
18. Neuber F. Fat grafting. *Cuir Kongr Verh Otsum Ges Chir* 1893; 20:66.
19. Gormley DE, Eremia S. Quantitative assessment of augmentation therapy. *J Dermatol Surg Oncol* 1990; 12:1147-1151.
20. Fournier PF. Microlipoextraction et microlipo-injection. *Rev Chir Anesthet Lang Franc* 1985; 19:421-425.
21. Coleman SR. Long-term survival of fat transplants. Controlled demonstrations. *Aesthetic Plast Surg* 1995; 19:421-425.
22. Dzubow L, Goldman G. Introduction to soft-tissue augmentation: a historical perspective. In: Klein AW, ed. *Tissue Augmentation in Clinical Practice: Procedures and Techniques*. New York: Marcel Dekker, 1998:1-22.
23. Spangler AS. New treatment for pitted scars. *Arch Dermatol* 1957; 76:708-711.
24. Gottlieb S. GAP repair technique. Poster presentation. Annual meeting of the American Academy of Dermatology, Dallas, TX, 1977.
25. Millikna L. Long-term safety and efficacy with Fibrel in the treatment of cutaneous scars-results of a multicenter study. *J Dermatol Surg Oncol* 1989; 15:837-842.
26. Gold MH. The Fibrel mechanism of action study. A preliminary report. *J Dermatol Surg Oncol* 1994; 20:586-590.
27. Treatment of depressed cutaneous scars with gelatin matrix implant: a multicenter study. *J Am Acad Dermatol* 1987; 16: 1155-1162.
28. Balazs EA, Delinger JL. Clinical uses of hyaluronan. In: Evered D, Whelan J, eds. *The Biology of Hyaluronan* (Ciba Foundation Symposium #143). Chichester and New York: John Wiley, 1989: 256-280.
29. Hamburger MI, Lakhanpal S, Mooar PA, et al. Intra-articular hyaluronans: a review of product specific safety profiles. *Semin Arthritis Rheum* 2003; 32:269-309.
30. Piacquadio DJ, Larsen NE, Denlinger JL, et al. Hylan B Gel (Hylaform) as a soft-tissue augmentation material. In: Klein AW, ed. *Tissue Augmentation in Clinical Practice: Procedures and Techniques*. New Work: Marcel Dekker, 1998:269-291.
31. Balazs EA, Bland PA, Denlinger JL, et al. Matrix engineering. *Blood Coag Fibrin* 1991; 2:173-178.
32. Goa KL, Benfield P. Hyaluronic acid. A review of its pharmacology and use as a surgical aid in ophthalmology, and its therapeutic potential in joint disease and wound healing. *Drugs* 1994; 46: 536-566.
33. Lemperle G, Ott H, Charrier U, et al. PMMA microspheres for intradermal implantation. Part I: Animal research. *Ann Plast Surg* 1991; 26:57-63.
34. Lemperle G, Hazan-Gauthier N, Lemperle N. PMMA microspheres for intradermal implantation. Part II: clinical investigations. *Ann Plast Surg* 1995; 96:627-634.
35. Lemperle G, Hazan-Gauthier N, Lemperle N. PMMA microspheres for long-lasting correction of wrinkles: refinements and statistical results. *Aesthetic Plast Surg* 1998; 22:356-365.
36. Soyer T, Lempler MA, Cooper P, et al. A new venous prosthesis. *Surgery* 1972; 72:864-872.
37. Florian A, Cohn LH, Dammam GJ, et al. Small vessel replacement with Gore-Tex. *Arch Surg* 1976; 111:267-270.
38. Bauer JJ, Salky BA, Gelernt IM, et al. Repair of large abdominal wall defects with ePTFE. *Ann Surg* 1987; 206:765-769.
39. Maas CS, Gnepp DR, Bumpous J. Expanded Gore-Tex in facial bone augmentation. *Arch Otolaryngol Head Neck Surg* 1993; 119: 1008-1015.
40. Waldman RS. Gore-Tex for augmentation of the nasal dorsum: a preliminary report. *Ann Plast Surg* 1991; 26:520-525.
41. Lassus C. Expanded PTFE in the treatment of facial wrinkles. *Aesthetic Plast Surg* 1991; 15:167-174.
42. Conrad K, Reifen E. Gore-Tex implant as a tissue filler in cheek-lip groove rejuvenation. *J Otolaryngol* 1992; 21:218-222.
43. Eillis DA, Trimas SJ. Gore-Tex implants for correction of thin lips. *Laryngoscope* 1995; 105:207-209.
44. Hanke CW. A new e-PTFE soft tissue implant for natural looking augmentation of lips and wrinkles. *Dermatol Surg* 2002; 28: 901-908.
45. Rubin PA, Fay AM, Remulla HD, et al. Ophthalmic plastic applications of acellular dermal allografts. *Ophtalmology* 1999; 106: 2091-2097.
46. Abenavoli FM, Coreli P, Vittori I. Use of AlloDerm for lip augmentation. *Ann Plast Surg* 2002; 48:447-448.
47. Klein AW. Collagen substitutes: bovine collagen. *Clin Plast Surg* 2001; 28:53-62.
48. Carruthers J, Carruthers A. Mad cows, prions and wrinkles. *Arch Dermatol* 2002; 138:667-670.
49. Klein AW. In favor of double skin testing. *J Dermatol Surg Oncol* 1989; 15:263.
50. Hanke CW, Coleman WP III. Dermal filler substances. In: Coleman WP III, Hanke CW, Alt TH, et al. eds. *Cosmetic Surgery of the Skin: Principles and Techniques*. 2nd edn. St Louis: Mosby Year Book, 1997:217-230.
51. Moody BR, Senglemann RS. Topical Tacrolimus in the treatment of bovine collagen hypersensitivity. *Dermatol Surg* 2001; 27:789-791.
52. Baumman LS, Kerdel F. The treatment of bovine collagen allergy with cyclosporine. *Dermatol Surg* 1999; 25:247-249.
53. Comper WD, Laurent TC. Physiological function of connective tissue polysaccharides. *Physiol Rev* 1978; 58:255-315.
54. Balasz EA, Darzynkiewicz Z. The effect of hyaluronic acid on fibroblasts, mononuclear phagocytes and lymphocytes. In: Kulonen E, Pikkariainen J, eds. *Biology of the Fibroblast*. London: Academic Press, 1973:237-252.
55. Ghersetich I, Lotti T, Campanile G, et al. Hyaluronic acid in cutaneous intrinsic aging. *Int J Dermatol* 1994; 22:119-122.
56. DeVore DP, Hughes E, Scott JB. Effectiveness of injectable filler materials for smoothing wrinkle lines and depressed scars. *Med Progr Technol* 1994; 20:243-250.
57. Reed RK, Laurent UB, Frazer JR, et al. Removal rate of (3H) hyaluronan injected subcutaneously in rabbits. *Am J Physiol* 1990; 259:H532-H535.
58. Duranti F, Salti G, Bovani B, et al. Injectable hyaluronic acid gel for soft-tissue augmentation: a clinical and histological study. *Dermatol Surg* 1998; 24:1317-1325.
59. Narins RS, Brandt F, Leyden J, et al. A randomized, double-blind, multicenter comparison of the efficacy and tolerability of Restylane versus Zyplast for the correction of nasolabial folds. *Dermatol Surg* 2003; 29(6):588-595.

60. Lindqvist C, Tveten S, Bondevik BE, et al. A randomized, evaluator-blind, multicenter comparison of the efficacy and tolerability of Perlane versus Zyplast in the correction of nasolabial folds. *Plast Reconstr Surg* 2005; 115(1):282-289.
61. Pinsky MA, Thomas JA, Murphy DK, et al.; Juvéderm vs. Zyplast Nasolabial Fold Study Group. Juvéderm injectable gel: a multicenter, double-blind, randomized study of safety and effectiveness. *Aesthet Surg J* 2008; 28(1):17-23.
62. Rao J, Chi GC, Goldman MP. Clinical comparison between two hyaluronic acid-derived fillers in the treatment of nasolabial folds: hylaform versus restylane. *Dermatol Surg* 2005; 31(11 pt 2):1587-1590.
63. Carruthers A, Carey W, De Lorenzi C, et al. Randomized, double-blind comparison of the efficacy of two hyaluronic acid derivatives, restylane perlane and hylaform, in the treatment of nasolabial folds. *Dermatol Surg* 2005; 31(11 pt 2):1591-1598.
64. Kono T, Kinney BM, Groff WF, et al. Randomized, evaluator-blind, split-face comparison study of single cross-linked versus double cross-linked hyaluronic acid in the treatment of glabellar lines. *Dermatol Surg* 2008; 34(suppl 1):S25-S30.
65. Narins RS, Dayan SH, Brandt FS, et al. Persistence and improvement of nasolabial fold correction with nonanimal-stabilized hyaluronic acid 100,000 gel particles/mL filler on two retreatment schedules: results up to 18 months on two retreatment schedules. *Dermatol Surg* 2008; 34(suppl 1):S2-S8; discussion S8.
66. Carruthers J, Carruthers A. A prospective, randomized, parallel group study analyzing the effect of BTX-A (Botox) and non-animal sourced hyaluronic acid (NASHA, Restylane) in combination compared with NASH (Restylane) alone in severe glabellar rhytids in adult female subjects: treatment of severe glabellar rhytids with a hyaluronic acid derivative compared with the derivative and BTX-A. *Dermatol Surg* 2003; 29:802-809.
67. Busso M. Soft tissue augmentation: nonsurgical approaches to treatment of the mid and lower facial regions. *Dermatol Nurs* 2008; 20(3):211-214, 217-219.
68. Rohrich RJ, Ghavami A, Crosby MA. The role of hyaluronic acid fillers (Restylane) in facial cosmetic surgery: review and technical considerations (review). *Plast Reconstr Surg* 2007; 120(6 suppl): 41S-54S.
69. Duffy DM. Complications of fillers: overview. *Dermatol Surg* 2005; 31:1626-1633.
70. Klein AW. Soft tissue augmentation 2006: filler fantasy (review). *Dermatol Ther* 2006; 19(3):129-133.
71. Alam M, Gladstone H, Kramer EM, et al; American Society for Dermatologic Surgery. ASDS guidelines of care: injectable fillers. *Dermatol Surg* 2008; 34(suppl 1):S115-S148.
72. Buck DW II, Alam M, Kim JY. Injectable fillers for facial rejuvenation: a review. *J Plast Reconstr Aesthet Surg* 2009; 62(1):11-18.
73. Sclafani AP. Soft tissue fillers for management of the aging perioral complex. *Facial Plast Surg* 2005; 21(1):74-78.
74. Ali MJ, Ende K, Maas CS. Perioral rejuvenation and lip augmentation (review). *Facial Plast Surg Clin North Am* 2007; 15(4):491-500, vii.
75. Sarnoff DS, Saini R, Gotkin RH. Comparison of filling agents for lip augmentation. *Aesthet Surg J* 2008; 28(5):556-563.
76. Beer KR. Rejuvenation of the lip with injectables. *Skin Therapy Lett* 2007; 12(3):5-7.
77. Glaich AS, Cohen JL, Goldberg LH. Injection necrosis of the glabella: protocol for prevention and treatment after use of dermal fillers. *Dermatol Surg* 2006; 32:276-281.
78. Schanz S, Schippert W, Ulmer A, et al. Arterial embolization caused by injection of hyaluronic acid (Restylane). *Br J Dermatol* 2002; 146:928-929.
79. Berlin A, Cohen JL, Goldberg DJ. Calcium hydroxylapatite for facial rejuvenation. *Semin Cutan Med Surg* 2006; 25(3):132-137. Review.
80. Jacovella PF, Peiretti CB, Cunille D, et al. Long-lasting results with hydroxylapatite (Radiesse) facial filler. *Plast Reconstr Surg* 2006; 118(3 suppl):15S-21S.
81. Marmur ES, Phelps R, Goldberg DJ. Clinical, histologic and electron microscopic findings after injection of a calcium hydroxylapatite filler. *J Cosmet Laser Ther* 2004; 6:223-226.
82. Carruthers A, Liebeskind M, Carruthers J, et al. Radiographic and computed tomographic studies of calcium hydroxylapatite for treatment of HIV-associated facial lipoatrophy and correction of nasolabial folds. *Dermatol Surg* 2008; 34(suppl 1): S78-S84.
83. Jansen DA, Graivier MH. Evaluation of a calcium hydroxylapatite-based implant (Radiesse) for facial soft-tissue augmentation. *Plast Reconstr Surg* 2006; 118(3 suppl):22S-30S; discussion 31S-33S.
84. Moers-Carpi M, Vogt S, Santos BM, et al. A multicenter, randomized trial comparing calcium hydroxylapatite to two hyaluronic acids for treatment of nasolabial folds. *Dermatol Surg* 2007; 33 (suppl 2):S144-S151.
85. Smith S, Busso M, McClaren M, et al. A randomized, bilateral, prospective comparison of calcium hydroxylapatite microspheres versus human-based collagen for the correction of nasolabial folds. *Dermatol Surg* 2007; 33(suppl 2):S112-S121; discussion S121.
86. Sadick NS, Katz BE, Roy D. A multicenter, 47-month study of safety and efficacy of calcium hydroxylapatite for soft tissue augmentation of nasolabial folds and other areas of the face. *Dermatol Surg* 2007; 33(suppl 2):S122-S126.
87. Tzikas TL. A 52-month summary of results using calcium hydroxylapatite for facial soft tissue augmentation. *Dermatol Surg* 2008; 34(suppl 1):S9-S15.
88. Busso M, Voigts R. An investigation of changes in physical properties of injectable calcium hydroxylapatite in a carrier gel when mixed with lidocaine and with lidocaine/epinephrine. *Dermatol Surg* 2008; 34(suppl 1):S16-S23.
89. Narins RS, Brandt FS, Lorenc ZP, et al. A randomized, multicenter study of the safety and efficacy of Dermicol-P35 and non-animal-stabilized hyaluronic acid gel for the correction of nasolabial folds. *Dermatol Surg* 2007; 33(suppl 2): S213-S221.
90. Woerle B, Hanke CW, Sattler G. Poly-L-lactic acid: a temporary filler for soft tissue augmentation. *J Drugs Dermatol* 2004; 3(4): 385-389.
91. Burgess CM, Quiroga RM. Assessment of the safety and efficacy of poly-L-lactic acid for the treatment of HIV-associated facial lipoatrophy. *J Am Acad Dermatol* 2005; 52(2):233-239.
92. Moyle GJ, Brown S, Lysakova L, et al. Long-term safety and efficacy of poly-L-lactic acid in the treatment of HIV-related facial lipoatrophy. *HIV Med* 2006; 7(3):181-185.
93. Leonard AL, Hanke CW. A protocol for facial volume restoration with poly-L-lactic acid. *J Drugs Dermatol* 2006; 5(9):872-877.
94. Leonard AL, Hanke CW. Surgical pearl: the use of a laboratory vortex for poly-L-lactic acid injection. *J Am Acad Dermatol* 2006; 55(3):511-512.
95. Hanke CW, Redbord KP. Safety and efficacy of poly-L-lactic acid in HIV lipoatrophy and lipoatrophy of aging. *J Drugs Dermatol* 2007; 6(2):123-128.
96. Piquet M, Brignol L, Chatelain B, et al. Polylactic acid injections: usefulness for the treatment of facial lipoatrophy in HIV+ patients under tritherapy. *Rev Stomatol Chir Maxillofac* 2007; 108(6):496-504.
97. Levy RM, Redbord KP, Hanke CW. Treatment of HIV lipoatrophy and lipoatrophy of aging with poly-L-lactic acid: a prospective 3-year follow-up study. *J Am Acad Dermatol* 2008; 59(6): 923-933.
98. Salles AG, Lotierzo PH, Gimenez R, et al. Evaluation of the poly-L-lactic acid implant for treatment of the nasolabial fold: 3-year follow-up evaluation. *Aesthetic Plast Surg* 2008; 32(5):753-756.
99. Cohen SR, Berner CF, Busso M, et al. ArteFill: a long-lasting injectable wrinkle filler material—summary of the U.S. Food and Drug Administration trials and a progress report on 4- to 5-year outcomes. *Plast Reconstr Surg* 2006; 118(3 suppl):64S-76S.

100. Cohen SR, Berner CF, Busso M, et al. Five-year safety and efficacy of a novel polymethylmethacrylate aesthetic soft tissue filler for the correction of nasolabial folds. *Dermatol Surg* 2007; 33 (suppl 2):S222–S230.
101. Bagal A, Dahiya R, Tsai V, et al. Clinical experience with polymethylmethacrylate microspheres (Artecoll) for soft-tissue augmentation: a retrospective review. *Arch Facial Plast Surg* 2007; 9(4):275–280.

### FURTHER READING

Alam M, Dover JS. Management of complications and sequela with temporary injectable fillers. *Plast Reconstr Surg* 2007; 120(6 suppl): 98S–105S.

Alam M, Levy R, Pavjani U, et al. Safety of radiofrequency treatment over human skin previously injected with medium-term injectable soft-tissue augmentation materials: a controlled pilot trial. *Lasers Surg Med* 2006; 38:205–210.

Hirsch RJ, Cohen JL, Carruthers JD. Successful management of an unusual presentation of impending necrosis following a hyaluronic

acid injection embolus and a proposed algorithm for management with hyaluronidase. *Dermatol Surg* 2007; 33: 357–360.

Hirsch RJ, Lupo M, Cohen JL, et al. Delayed presentation of impending necrosis following soft tissue augmentation with hyaluronic acid and successful management with hyaluronidase. *J Drugs Dermatol* 2007; 6:325–328.

Lowe NJ, Maxwell CA, Lowe P, et al. Hyaluronic acid skin fillers: adverse reactions and skin testing. *J Am Acad Dermatol* 2001; 45(6): 930–933.

Lowe NJ, Maxwell CA, Patnaik R. Adverse reactions to dermal fillers: review. *Dermatol Surg* 2005; 31:1616–1625.

Matarasso SL, Herwick R. Hypersensitivity reaction to nonanimal stabilized hyaluronic acid. *J Am Acad Dermatol* 2006; 55: 128–131.

Narins RS, Brandt FS, Lorenc ZP, et al. Twelve-month persistency of a novel ribose-cross-linked collagen dermal filler. *Dermatol Surg* 2008; 34(suppl 1):S31–S39.

Parada MB, Michalany NS, Hassun KM, et al. A histologic study of adverse effects of different cosmetic skin fillers. *Skinmed* 2005; 4: 345–349.

Shafir R, Amir A, Gur E. Long-term complications of facial injections with Restylane (injectable hyaluronic acid). *Plast Reconstr Surg* 2000; 106:1215–1216.



# Bioelectricity

Ying Sun and Jue-Chen Liu

## INTRODUCTION

Mankind's interest in using electricity to treat ailments has a very long history. The electric torpedo fish was used to shock people to treat headache and gout over two centuries ago (1). The importance of the electrical control of cell physiology became apparent from the famous experiments of Galvani. His epic work on frog nerve-muscle preparations included the use of lightning rods connected to nerves via wires resulting in leg muscles twitching during a lightning storm. Similarly, static electricity generators creating sparks that activated nerve conduction also caused muscle to twitch. Equally important was his observation during a public experiment in Bologna in 1794 that the cut end of a frog sciatic nerve from one leg stimulated contractions when it touched the muscles of the opposite leg.

Collectively, these experiments provided definitive evidence for "animal electricity" (bioelectricity). In addition, with this last experiment, Galvani had demonstrated the existence of the injury potential. An injury potential is a steady, long-lasting direct current voltage gradient induced within the extracellular and intracellular spaces by current flowing into and around an injured nerve. This discovery predated the finding of the better-known action potential, which is a rapid, self-regenerating voltage change localized across the cell membrane (2). In parallel with Galvani's work, Volta was developing these ideas to create the first battery. Recognizing the parallel with animal electricity, Volta used batteries therapeutically to treat deafness. Others, however, were less rigorous scientifically in the promotion of electrical-based therapies.

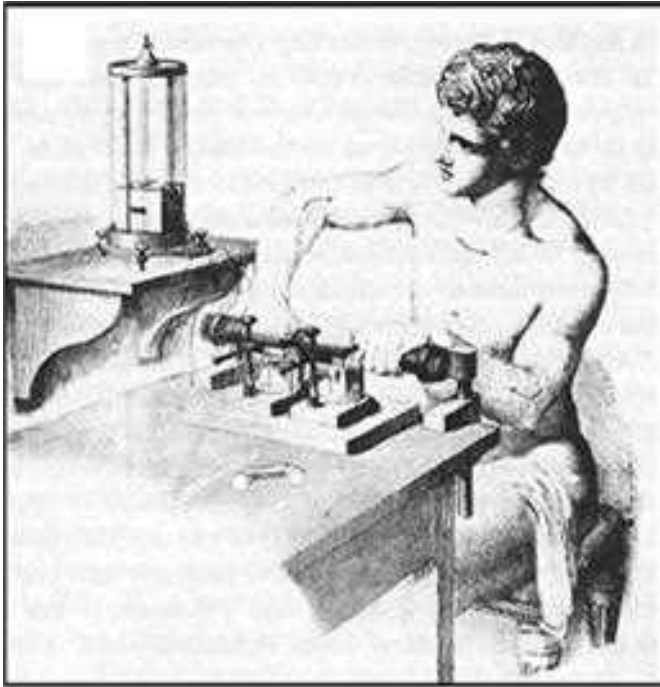
For more than a century, there has been widespread and irrational use of galvanism and static electricity. Static electricity generators were in common use and were promoted and sold because they created an allegedly beneficial "electric air bath" or a "negative breeze." The electric air bath involved charging the patient and using a grounded electrode to draw sparks from a chosen part of the body. The negative breeze allegedly was helpful in treating insomnia, migraine, and baldness. With the electrode polarity reversed, a "positive breeze" was used to treat kidney disease (2).

Naturally occurring electric currents at human skin wounds were measured by a German physiologist Emil Du Bois-Reymond over 160 years ago (Fig. 53.1). As a founder of modern electrophysiology, he documented in detail the electric activities associated with nerve excitation, muscle contraction, and wounds. While electric activities in the nervous system and muscles are prevailing concepts in science, however, the wound electric fields have remained very poorly understood and largely ignored until recently. Modern technologies, such as vibrating probe, glass, and platinum microelectrodes have

been used to confirm and provide significant understanding of the wound electric fields.

Therapeutic applications of electrotherapy may be generally grouped into two areas: electric neurostimulation and biomimetic electric stimulation. Electric neurostimulation applications are well known and relatively well studied. Electric neurostimulation devices can either be implanted inside the body such as the cardiac pacemaker or be applied to the skin surface such as transcutaneous electrical nerve stimulation (TENS) devices. While better mechanistic understanding has been achieved with electric neurostimulation applications, much less well understood is the biomimetic electric stimulation that utilizes very low electric potential and current intensity for tissue healing and regeneration. In contrast to electric neurostimulation, the microamperage of electricity used in biomimetic electric stimulation is typically below the threshold of human sensory detection. This threshold is similar in magnitude to the body's own bioelectricity, hence the terminology biomimetic electric stimulation. While electric neurostimulation offers a surprisingly wide range of therapeutic applications and possibilities, the potential of electric biomimetic stimulation is equally promising due to its tissue regenerative ability. Historically, there have been periodic interests in the bioelectricity and use of biomimetic electricity for therapeutic applications. However, because of the separate research paths between the biophysics and modern cellular biology and molecular biology, a knowledge gap exists between the biophysical and biochemical research.

It is well known that specific levels of electric current intensity can induce biological responses (3). There are some general thresholds (as approximate reference points) corresponding to different tissue responses to electrical current. The passage of a high electrical current ( $>100\text{--}200\text{ mA}$ ) through the human body may result in serious injury or tissue damage such as cardiac excitation, fibrillation, or electrical burns. If greater than  $1000\text{ mA}$ , the electric current may cause defibrillation or even fatality. Low to moderate electrical currents ( $1\text{--}20\text{ mA}$ ) are generally considered safe and have been applied to patients for neuron stimulation for a wide variety of therapeutic applications (Fig. 53.2) (3–5). When an ultralow electrical current ( $10\text{--}1000\text{ }\mu\text{A}$ ) is applied to a patient, the electrical stimulation of the skin tissue cannot be perceived by the patient because it is below the sensory detection threshold of the skin. Nevertheless, the biological responses of the tissue under the treatment are as profound as, if not more than, the neurostimulation by commonly known electrotherapeutic modalities. Therefore, the focus of this chapter is on less commonly known ultralow microampere electrical stimulation of tissues and its potential applications to cosmetic dermatology.



**Figure 53.1** Endogenous wound electric fields—measurement of endogenous wound electric currents from a cut in his own finger by Du Bois-Reymond. *Source:* From Ref. 2.

## TRANSCUTANEOUS ELECTROTHERAPY AND DELIVERY ENHANCEMENT

Transcutaneous electrotherapy is one of the fundamental elements of physiotherapy practice and sports medicine with widespread applications including TENS, and interferential current, as well as microcurrent therapy for pain control and wound healing.

Electrical devices and battery-powered patches are used for topical or transdermal drug administration via iontophoresis, and electrical stimulation in various medical practices such as pain and chronic wound management (6,7) and dermatology (8,9).

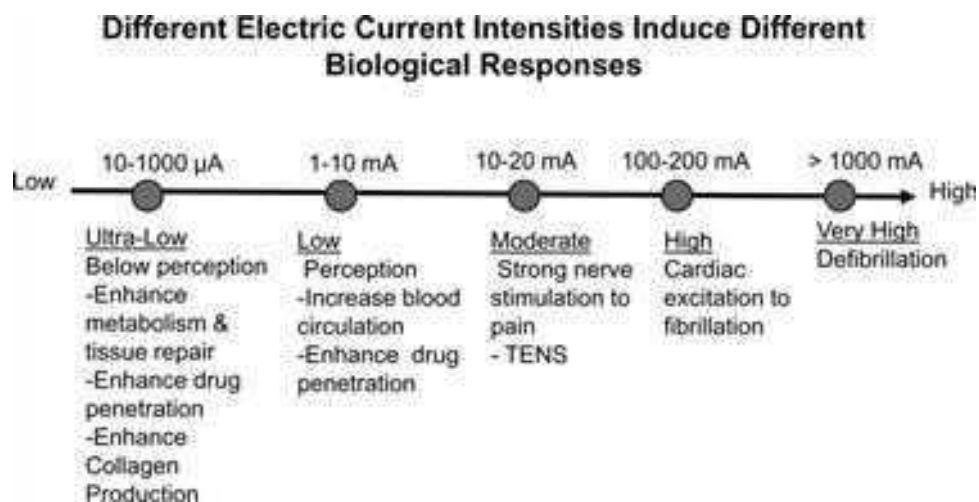
### Ultralow Intensity Electricity Therapy

It has been reported that direct electric currents ranging from 10 to 1000  $\mu\text{A}$  increase ATP concentrations in the tissue and stimulate amino acid incorporation into the proteins of rat skin. Minimum current intensities of approximately 50  $\mu\text{A}$  are necessary to obtain a maximal stimulatory effect on protein synthesis. When higher currents at a range above 1000  $\mu\text{A}$  are applied, the current failed to increase ATP levels significantly. These stimulatory effects are maintained to a level of approximately 1000  $\mu\text{A}$  (10). The application of specific low-intensity currents for the metabolic effects implies a new area for exploration. The amino acid transport through the cell membrane, followed by the  $\alpha$ -aminoisobutyric acid uptake, is stimulated between 100 and 750  $\mu\text{A}$ . The stimulatory effects on ATP production and amino acid transport, apparently mediated by different mechanisms, contribute to the final increased protein synthesizing activity; DNA metabolism followed by thymidine incorporation remains unaffected during the course of current application. The effects on ATP production can be explained by proton movements on the basis of the chemiosmotic theory of Mitchell, while the transport functions are controlled by modifications in the electrical gradients across the membranes.

The microcurrent treatment was reported to be more effective than conventional therapy for chronic Achilles tendinopathy in a randomized comparative trial (11). The healing processes of tendon tissue remain to be explored.

## BIOELECTRICITY

Human body has its own innate electrical system that regulates body's functions via communications among organs through the well-known neural system, and some less understood



**Figure 53.2** Different electrical current intensities produce different biological responses. Ultralow electric current intensity in the range of 10 to 500  $\mu\text{A}$  is known to have regenerative activity, whereas higher current intensities in 1 to 20 mA have neuron-stimulation activity. Above certain thresholds of electric current intensities, adverse effects such as cardiac excitation, fibrillation, or defibrillation may occur. (Note: these electric current intensities only serve as approximate reference points rather than precise threshold values.)

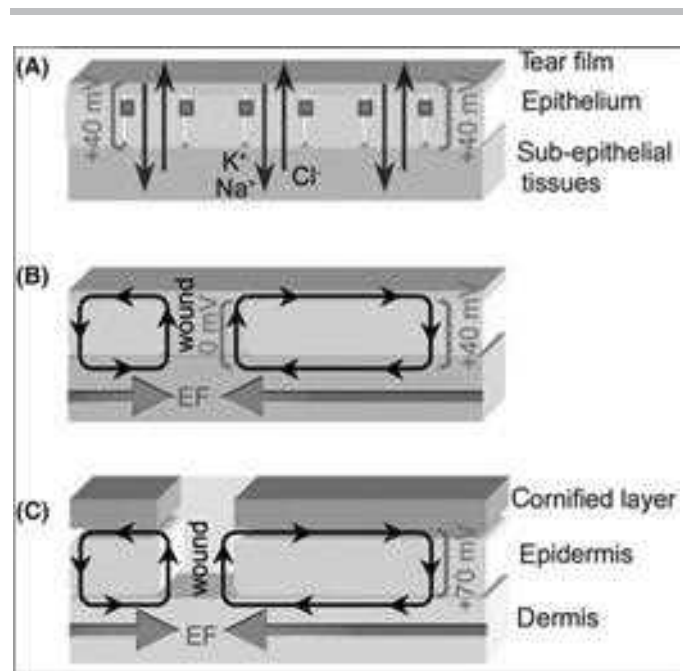
cellular activities such as the bioelectricity associated with tissue regeneration (12). When injured, the body generates a low-level wounding electricity to facilitate the healing process, for example, human skin generates up to  $10 \mu\text{A}/\text{cm}^2$  of outward bioelectric current during healing, and common signaling pathways are able to steer cell movement in both electrical and chemical gradients (13,14).

Most recently developed microneedle arrays are able to measure the transdermal skin potentials at multiple sites simultaneously. Bio-Electric Field Imager<sup>®</sup> detects and visualize electric potential at skin surface without direct skin contact, which will be discussed in detail in a later section.

The measurable bioelectricity during the wound healing process has been described as the endogenous “skin battery” that pumps sodium ions from the exterior of the epithelium to the interior using the Na/K-ATPase located on the basal surface of epidermal cells together with Na<sup>+</sup> channels on the apical surface with an outward electric current of about 10 to  $100 \mu\text{A}/\text{cm}^2$  and an electric potential gradient about 60 mV/mm around the wound (1). The bioelectric field and current can be detected within about 0.5 to 1 mm from the edge of the wound and last until the wound is re-epithelialized (2). For an intact epithelium (or skin), because of the Na<sup>+</sup> transported inward is not completely balanced out by anion movement, an excess of positive charge accumulated results in positive potential of the epithelium membrane, that is, transepithelial potential (TEP) as shown in Figure 53.3A. However, if the epithelium is perforated by a wound as shown in Figures 53.3B and C, the potential drives the current flow through the newly formed low resistance path generating an electric field with the negative pole at the wound and the positive under the unbroken epithelium or skin surrounding the wound that behaves just like a battery. Hence, the term “skin battery,” which is sometimes used to describe the bioelectricity phenomena influencing healing of a skin wound.

As mentioned earlier, endogenous DC electric fields occurred naturally during skin injury was first demonstrated in wounds by Emil DuBois-Reymond over 150 years ago. He measured electric currents flowing out of a cut he made in his own finger as shown in Figure 53.1. In recent studies with various modern techniques such as microglass electrodes and vibrating probes, scientists confirmed a similar electric current flow in wounds in both the skin and cornea of several species including human skin (14). In cornea and skin, a laterally oriented, wound-induced electric field is generated instantaneously when the epithelium is damaged, and it persists until re-epithelialization restores the electrical resistance barrier function of the epithelium. These electric fields are estimated to be at least 40 to 50 mV/mm at cornea wounds and 100 to 150 mV/mm at skin wounds (2). Growing experimental evidence suggests an important role for such electric signals in directing cell migration in wound healing.

Endogenous DC electric fields have also been measured during development and regeneration and after damage to nonepithelial tissues. These electric fields arise because of spatial and temporal variations in epithelial transport of charged ions such as Na<sup>+</sup>, K<sup>+</sup>, and Cl<sup>-</sup>, and spatial variations in the electrical resistance of epithelial sheets. Disruption of the endogenous electrical gradients during development induces skeletal and neural abnormalities. For example, it has been reported that the spinal cord responds to damage by generating large and persistent electrical signals. Conceivably, externally applied electric stimulation of physiological magnitude can

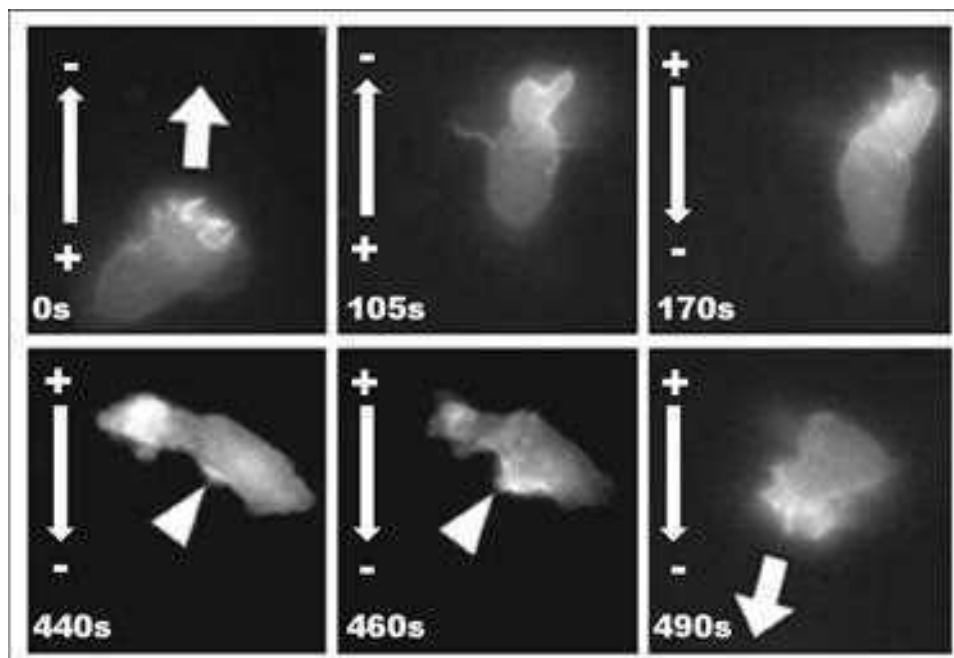


**Figure 53.3** Wounding collapses the transepithelial electric potential (TEP) locally, resulting in an electric field lateral to the plane of the epithelium. (A) Intact mammalian corneal epithelium maintains a uniform TEP of 40 mV. This results from net inward transport of K and Na from the tear fluid and the net outward transport of Cl from the cornea into the tear fluid. The TEP is maintained by the presence of tight junctions (squares). (B) Upon wounding, the epithelial seal is broken. The TEP collapses catastrophically to 0 mV at the wound, and ions immediately begin to leak out establishing an injury current (curved arrows), which persists until the leak is sealed by re-epithelialization. However, the TEP is maintained distally at 40 mV, and this gradient of electrical potential establishes an electric field within corneal tissues (horizontal arrow). (C) Ion transport (predominantly inward transport of Na) properties of mammalian skin also result in a substantial TEP, which establishes an injury current (curved arrows) upon wounding and an electric field within the subepithelial tissues (horizontal arrow). In this case, the return path for the current is in the layer between the dead, cornified tissue and the living epidermis. *Source:* From Ref. 2.

promote spinal cord repair in human and other mammals (21,23).

It is now generally accepted that there are endogenous electric fields associated with wounds, and disruption of these electric fields interferes with wound healing. Research has been conducted into cellular response to electric fields for several decades. Among the various signals hypothesized to guide cell migration and division in development and wound healing, electric signals have not been well studied. The biological and medical research community generally is not familiar with the possible roles of electric fields as a directional signal in guiding cell migration to heal a wound. The lack of rational explanation for the mechanism of bioelectricity on tissue regeneration has led to skepticism, especially when modern molecular biology and electrophysiology has taken different approaches to the phenomenon, and few researchers are really at home in both fields (1).

It has been repeatedly demonstrated by in vitro experiments that electric fields of strength similar to those measured



**Figure 53.4** The effect of electric signal in directing the migration of human keratinocyte cell in wound healing. It shows a promyelocytic cell with its leading edge labeled with a probe that detects PIP3 production. The narrow arrows at the top left show the gradient of electric potential in which the cells are migrating. The wide arrows show the direction of cellular movement. Reversal of the polarity of the electric field is followed by a change in locale of PIP3 to a region that becomes the new leading edge shown by arrowheads. *Source:* From Ref. 14.

in vivo dictate important cell behaviors such as directional cell migration and cell division orientation. Zhao et al. (13) provides further experimental evidence that the electric signal as a directional cue probably plays a far more important role in directing cell migration in wound healing of epithelium than previously believed, and two genes are important for electric field-induced cellular response. It was showed that polarized phosphatidylinositol 3-kinase (PI3K) signaling steers the migration of human cells across a gradient of electric potential, a process called electrotaxis. The lipid phosphatidylinositol 3,4,5-triphosphate (PIP3) appears to be a pivotal molecule. It is concentrated at the leading edge of the cell, where signaling components bind to it. These signaling components, in turn, lead to the localized polymerization of actin and the formation of a protrusion in the direction of migration (14). Figure 53.4 shows a promyelocytic cell with its leading edge labeled with a probe that detects PIP3 production. The narrow arrows at the top left show the gradient of electric potential in which the cells are migrating. The wide arrows show the direction of cellular movement. Reversal of the polarity of the electric field is followed by a change in locale of PIP3 to a region that becomes the new leading edge shown as arrowheads.

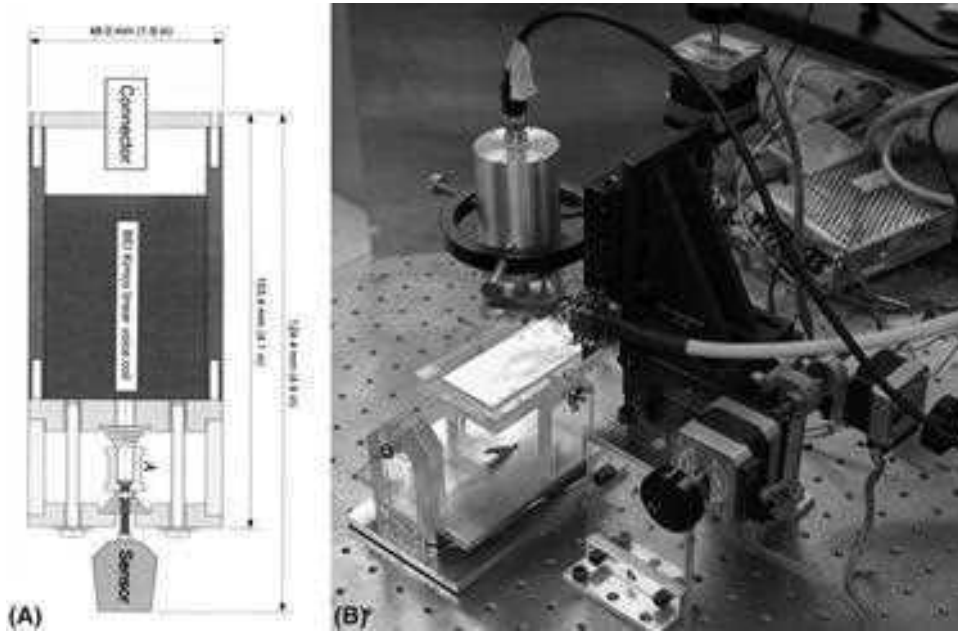
### RECENT SCIENTIFIC ADVANCES IN APPLICATIONS OF BIOELECTRICITY/BIOMIMETIC ELECTRICITY

The application of biomimetic electrical stimulation similar to body's own bioelectricity has been used to achieve clinical efficacy, particularly in healing enhancement of chronic wounds (15–17), as well as to perform various in vitro and

in vivo investigation on cellular activities to result in the effects of physiological level of electricity on tissues (18–25) or to utilize its power for tissue engineering (26). It was reported that the biomimetic electric field appeared to play an important role in controlling human fibroblast activity by either significantly increasing or decreasing gene expression of over 400 transcripts investigated, including activity within specific cellular signaling pathways such as TGF- $\beta$ , G-proteins, and inhibition of apoptosis.

### BIOELECTRICITY OF THE SKIN WOUNDS AND ITS CONNECTION TO SKIN AGING

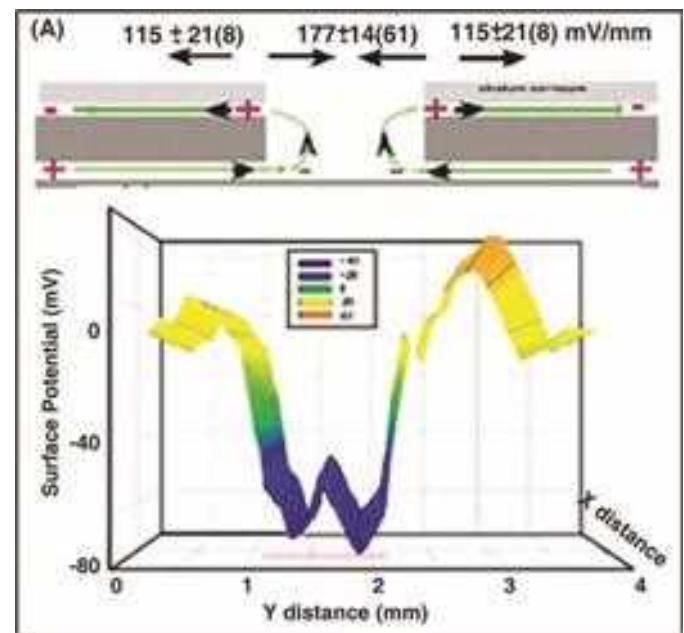
The epidermis generates a TEP of 20 to 50 mV across itself inside positive. Any wound or break in the epidermis creates a low resistance pathway and the TEP at the wound site is 0 mV. However, the TEP of the intact epidermis around the wound is still present, resulting in a lateral voltage gradient or electric field along the skin surrounding the wound. There is evidence that this lateral electric field stimulates keratinocytes in the area to migrate toward the wound with the optimal response occurring at field strength of 100 mV/mm. To determine the actual fields strength at the edge of human wounds, Nuccitelli et al. (27) developed a new instrument that vibrates a small sensor perpendicular to the skin about 100  $\mu$ m above the surface and uses the oscillating capacitance signal to determine the surface potential of the epidermis just beneath the stratum corneum. By measuring this surface potential in many positions around the wound, a spatial map of the surrounding electric field was generated. On the basis of an ultrasensitive vibrating probe technique for measuring extracellular currents (27), a sensitive



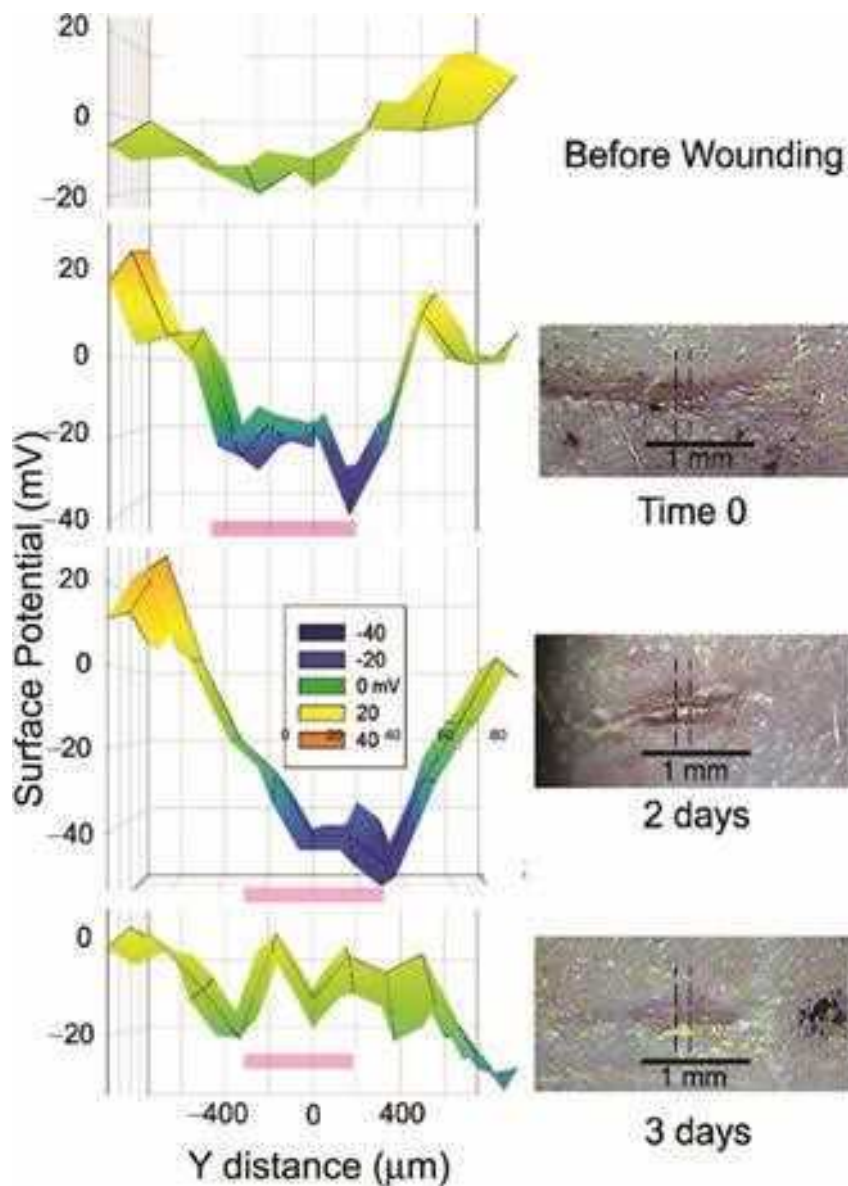
**Figure 53.5** Bioelectric field imager (BFI) vibrator and motorized manipulator. (A) Diagram of the vibrator using a voice coil (BEI Kimco LA 16-27-000A, Vista, California, U.S.). The vibrator assembly incorporates two springs to hold the probe in place when the voice coil is not powered. (B) Photograph of motorized manipulator used to position BFI above a wound in mouse skin. An adjustable mouse platform maintained at 37°C is shown on the lower left and the cylinder above it is the vibrator. *Source:* From Ref. 28.

noninvasive bioelectric field imager was developed by Nuccitelli et al. (28) as shown in Figure 53.5 and was used to measure the bioelectric wound current in vivo in mice. A more detailed description of the vibrating probe equipment setup and technique was given by Reid et al. (29). A noninvasive instrument based on the principle of vibrating probe (named as bioelectric field imager or BFI) was used for mapping the electric field between the epidermis and the stratum corneum near wounds in both mouse and human skin (28). Rather than touching the skin, the vibrating probe vibrates a small metal probe with a displacement of 180 μm in air above the skin to detect the surface potential of the epidermis through capacitive coupling. The application of the vibrating probe device was demonstrated by measuring the electric field between the stratum corneum and epidermis at the margin of skin wounds in mice (Fig. 53.6). An electric field of 177 ± 14 mV/mm was measured immediately upon wounding and the field lines pointed away from the wound in all directions around it. Because the wound current flows immediately upon wounding, this is the first signal indicating skin damage. This electric field is generated at the outer surface of the epidermis by the outward flow of the current of injury. An equal and opposite current must flow within the multilayered epidermis to generate an intraepidermal field with the negative pole at the wound site. Because the current flowing within the multilayered epidermis is spread over a larger area, the current density and subsequent E field generated in that region is expected to be smaller than that measured by the BFI beneath the stratum corneum. The field beneath the stratum corneum typically remained in the 150 to 200 mV/mm range for three days and then began to decline over the next few days, falling to zero once wound healing was complete. Figure 53.7 shows the bioelectric field imager scans of

the mouse skin wounds over time. It can be seen that wounding resulted in the development of wound electric potential, which persisted until the wound closed at Day 3. Nuccitelli et al. (28) also demonstrated that the wounding electric field can be



**Figure 53.6** Photomicrograph of a larger, nonlinear wound. (I) Two-dimensional BFI scan of wound in H. *Source:* From Ref. 28.



**Figure 53.7** Bioelectric field imager (BFI) scans of skin wounds over time. Mouse skin wound scanned before and at the indicated times after wounding. The precise region that was scanned is indicated by the dotted lines on the micrographs. Pink bar on the BFI scan indicates the location of the wound. *Source:* From Ref. 28.

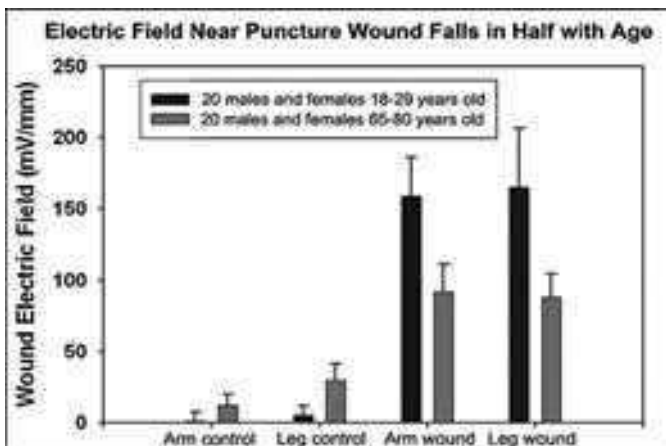
modified by topically applied pharmacological agents. The mean wound field strength decreased by  $64 \pm 7\%$  following the application of the sodium channel blocker, amiloride, to the skin near the wound and increased by  $82 \pm 21\%$  following the application of the  $\text{Cl}^-$  channel activator, prostaglandin E2. This experimental evidence suggests that both sodium ion influx and chloride ion efflux are maintaining the TEP of the skin and are carrying the wound current.

Recently, a similar bioelectric field imager, a commercially available Dermacorder<sup>®</sup> (BioElectroMed, Burlingame, California, U.S.) was used to measure human skin's wound current in two test subject groups to investigate the role of endogenous electric fields in wound healing of young and old human subjects (30). The lateral surface wound field was measured between the stratum corneum and epidermis near a

lancet wound on the arm and leg in 40 adults by Dermacorder as shown in Figure 53.8. Ten women and 10 men in 18- to 29-year old age group exhibited a mean electric field of 163.59 mV/mm. Ten women and 10 men in the 65 to 80 age range exhibited a mean field of 78.15 mV/mm. Therefore, the mean electric field of individuals in the older age group is only half that of the younger group (Fig. 53.9). Since the wound electric potential is linked with the healing, the reduced wound electric potential may be a contributing factor to well-known decreased healing rate associated with wound healing among elderly. On the other hand, it is conceivable that if an external electric potential of physiological magnitude of electric would be applied on the wounds of these elderly to bring it to the level of the wound electric potentials among the younger subjects, the wound healing rates of these elderly might be enhanced.



**Figure 53.8** The DermaCorder™, a commercially available vibrating probe device, was used to measure wound electric potential by Nuccitelli et al. to investigate the effect of age on wound electric potentials in human subjects. *Source:* From Ref. 30.



**Figure 53.9** Ten women and 10 men in the young group (18–29 years) exhibited a mean electric field of 16359 mV/mm, which is twice as much as the mean field of 7815 mV/mm exhibited by the 10 women and 10 men in the old group (65–80 years). *Source:* From Ref. 30.

### CELLULAR EFFECTS OF ELECTRICITY OF PHYSIOLOGICAL MAGNITUDE

In a well-cited study, Cheng et al. (10) reported an *in vitro* study to examine the cellular effects of low-intensity direct electric current on freshly excised rat skin. Direct electric currents ranging from 10 to 1000  $\mu\text{A}$  increased ATP concentrations about 500% in the tissue and stimulated amino acid incorporation into the proteins of skin tissues. Minimum current intensities of approximately 50  $\mu\text{A}$  were necessary to obtain a maximal stimulatory effect on protein synthesis. The amino

acid transport through the cell membrane, followed by the  $\alpha$ -aminoisobutyric acid uptake, was stimulated between 100 and 750  $\mu\text{A}$ . The stimulatory effects on ATP production and on amino acid transport, apparently mediated by different mechanisms, contributed to the final increased protein-synthesizing activity. DNA metabolism followed by thymidine incorporation remained unaffected during the course of current application. The highest stimulatory effects were obtained with 50 to 1000  $\mu\text{A}$ , with glycine incorporation increased by as much as 75% compared with nontreated controls. Higher current intensities, exceeding 1000  $\mu\text{A}$ , inhibited the protein synthesis by as much as 50% with currents of 15,000  $\mu\text{A}$ . Constant currents from 100 to 500  $\mu\text{A}$  increased the transported amino acid analog by 30% to 40% above control levels. Stimulation with higher intensities reduced the  $\alpha$ -aminoisobutyric acid uptake. The effects on ATP production can be explained by proton movements on the basis of the chemiosmotic theory of Mitchell, while the transport functions are controlled by modifications in the electrical gradients across the membranes.

During the course of normal wound healing, fibroblasts at the wound edge are exposed to electric fields ranging from 40 to 200 mV/mm. Various forms of electric fields influence fibroblast migration, proliferation, and protein synthesis. Thus, electric fields may contribute to fibroblast activation during wound repair. To elucidate the role of electric fields during the normal progression of healing, Jennings et al. (20) compared gene expression in normal adult dermal fibroblasts exposed to a 100 mV/mm electric field for 1 hour to nonstimulated controls. Significantly increased expression of 162 transcripts and decreased expression of 302 transcripts was detected using microarrays, with 126 transcripts above the level of 1.4-fold increases or decreases compared to the controls. Above the level of twofold, only 11 genes were significantly increased or decreased compared to controls. Many of these significantly regulated genes are associated with wound repair through the processes of matrix production, cellular signaling, and growth. Activity within specific cellular signaling pathways is noted, including TGF- $\beta$ , G-proteins, and inhibition of apoptosis. In addition, RT-PCR analysis of the expression of KLF6, FN1, RGS2, and JMJD1C over continued stimulation and at different field strengths suggests that there are specific windows of field characteristics for maximum induction of these genes. Electric fields thus appear to have an important role in controlling fibroblast activity in the process of wound healing.

Endogenous electric fields are generated lateral to skin wounds, with the cathodal pole of the field residing in the center of the wound. These fields are thought to be an important mechanism in guiding the migration of keratinocytes and other cells into wounds to effect healing. Sillman et al. (25) studied human dermal fibroblasts exposed to direct current electric fields of physiological strength, and quantified their migrational behavior. It was observed that human dermal fibroblasts moved only randomly, not directionally in direct current electric fields under conditions that support the directional migration of human epidermal keratinocytes. Additionally, neither the presence of the serum nor the serum plus additional  $\text{Mg}^{2+}$  in the experimental medium supported the directional migration. Migratory rates of fibroblasts varied depending on the experimental medium used: in serum-containing medium the average velocity was as low as 0.23  $\mu\text{m}/\text{min}$ , while in serum-free keratinocyte medium the average velocity was as high as 0.36  $\mu\text{m}/\text{min}$ . These studies suggest that dermal fibroblasts do not respond to the endogenous electric

field of a wound, and use other migratory cues to direct their movement into the wound bed.

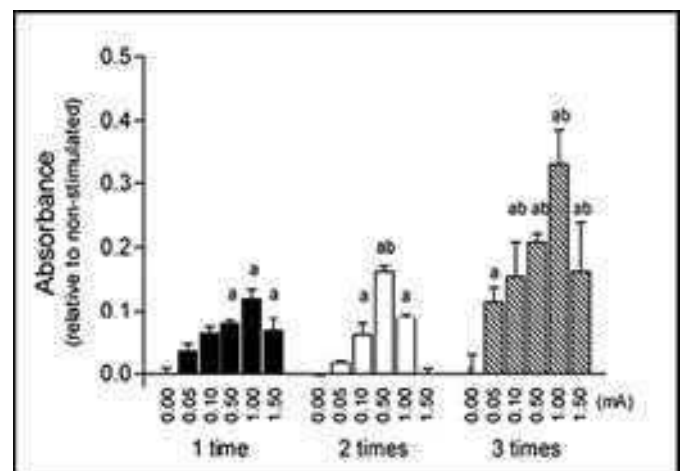
Directional cellular locomotion is thought to involve localized intracellular calcium changes and the lateral transport of cell surface molecules. Brown et al. (26) examined the roles of both calcium and cell surface glycoprotein redistribution in the directional migration of two murine fibroblastic cell lines, in contrast to human dermal fibroblast result reported by Sillman et al. (25) and directional migration of NIH 3T3 and SV101. These cell types exhibit persistent, cathode-directed motility when exposed to direct current electric fields. Using time lapse phase contrast microscopy and image analysis, we have determined that electric field-directed locomotion in each cell type is a calcium-independent process. Both exhibit cathode-directed motility in the absence of extracellular calcium, and electric fields cause no detectable elevations or gradients of cytosolic free calcium. On the basis of the evidence, the authors suggested that galvanotaxis in these cells involves the lateral redistribution of plasma membrane glycol proteins. Electric fields cause the lateral migration of plasma membrane concanavalin A (Con A) receptors toward the cathode in both NIH 3T3 and SV101 fibroblasts. Exposure of directionally migrating cells to Con A inhibits the normal change of cell direction following a reversal of electric field polarity. Additionally, when cells are plated on Con A-coated substrata so that Con A receptors mediate cell-substratum adhesion, cathode-directed locomotion, and a cathodal accumulation of Con A receptors are observed. Immunofluorescent labeling of the fibronectin receptor in NIH 3T3 fibroblasts suggests the recruitment of integrins from large clusters to form a more diffuse distribution toward the cathode in field-treated cells. It was concluded that the mechanism of electric field-directed locomotion in NIH 3T3 and SV101 fibroblasts involves the lateral redistribution of plasma membrane glycol proteins involved in cell substratum adhesion.

### Bioelectricity and Skin Pigmentation

Wounding skin generates endogenous electric fields of 100 to 200 mV/mm in the immediate vicinity of the wound. When keratinocytes are exposed to direct current electric fields of this magnitude, they exhibit galvanotaxis, or directional migration toward the cathode, suggesting that wound-generated electric fields provide migrational cues that contribute to wound healing. Because melanocytes must also migrate into the healing wound to repigment it, their motility in response to electric fields of physiologic magnitude was examined. Human skin-derived melanocytes, either exposed to 100 mV/mm direct current electric fields or nonexposed controls, both exhibited motility rates of 9  $\mu\text{m/hr}$ , significantly (three- to fivefold) lower than the motility rates of keratinocytes under identical conditions. However, Grahn et al. (31) reported that in sharp contrast to keratinocytes, melanocytes exhibited no directional migration in the electric field. Additionally, neither the number of primary dendrites per cell, nor the orientation of the dendrites with respect to the field vector and the average length of the dendrites was significantly different in melanocytes exposed to the electric field as compared to nonexposed controls. Thus, in marked contrast to keratinocytes, human skin-derived melanocytes do not respond to direct current electric fields of physiologic magnitude with either directional migration or reorientation of dendrites. This may account for the delay in repigmentation that often accompanies wound re-epithelialization.

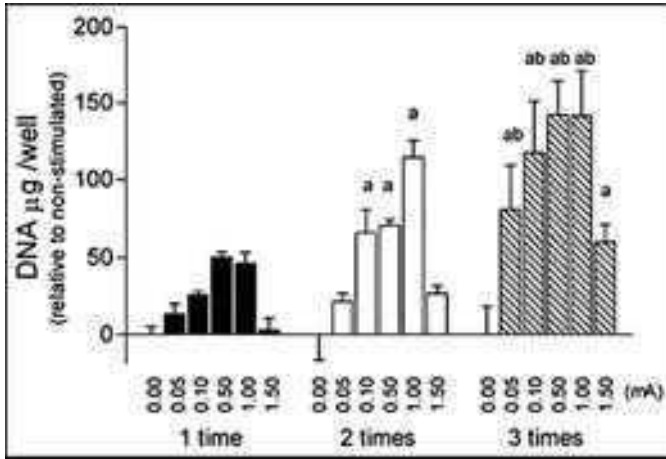
### Bioelectricity Ranges and Cell Proliferation

Yi-lo Lin et al. (32) used tissue cultures of tendon fibroblasts or tenocytes taken from 20 horses. Cells from these cultures were used for microcurrent stimulation (METS) experiments. The METS device delivered a waveform consisting of a brief monophasic square pulse, duration 0.8 milliseconds. The pulse frequency was 150 Hz. Electrical current consisted of 0, 0.05, 0.1, 0.5, and 1.5 mA. To assess the effects of METS on tenocyte proliferation, viable cells were quantified by use of a non-radioactive, colorimetric cell proliferation kit (Cell Proliferation Kit II XTT, Roche Molecular Biochemicals, Basel, Switzerland). The spectrophotometric absorbency measured was proportional to the cell proliferation. The investigators found that application of microcurrent had a stimulatory effect on cell proliferation that was significantly increased with repeated microcurrent applications (Fig. 53.10). Same results were observed for DNA content, except that a single application of microcurrent did not lead to a significant DNA content increase in comparison with the control sample. However, repeated microcurrent application significantly increased DNA content (Fig. 53.11). Protein content significantly increased after one application of 0.5 and 1 mA, and after two applications of 0.1, 0.5, and 1 mA of microcurrent. However, application of microcurrent three times significantly decreased protein content. Apoptosis rate did not alter after the first application. However, after the third microcurrent application, apoptosis rate significantly increased with increasing current intensity so that the highest rate of apoptosis occurred at 1.5 mA. The results of this study provides some evidence for the positive effects of microcurrent on cell proliferation, DNA, and protein content; however, it raises questions as to the specifications and specific ranges of microcurrent necessary to produce optimum cell proliferation, DNA, and protein content while minimizing apoptosis. Cheng et al. (10) who studied the effects of milli-ampere (mA) and microcurrent on ATP generation protein synthesis and membrane transport showed that although low microcurrent stimulated physiologic activity of damaged cells and increased ATP up to 500%, ATP progressively decreased at



**Figure 53.10** Effect of METS on cell proliferation of tenocytes in culture. Repeated application of microcurrent resulted in significantly increased cell proliferation.





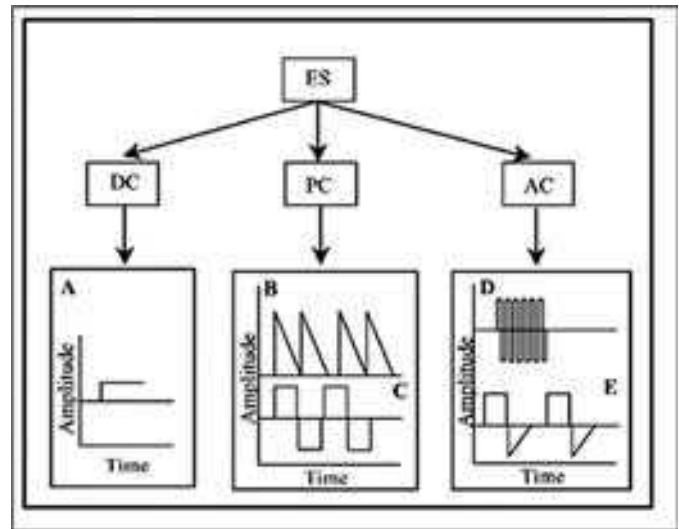
**Figure 53.11** Effect of METS on DNA content of tenocytes in culture. Repeated application of microcurrent resulted in significantly increased DNA content, whereas a single application of METS did not cause increased DNA in comparison to the control.

mA ranges and fell to 0 around 1.5 mA. Therefore, the cell apoptosis, observed in Yi-lo Lin et al. study (32) cited earlier, which appeared to be maximum with repeated applications of 1.5 mA, may well be the result of milliamperage ranges depleting ATP.

**WOUND HEALING ENHANCEMENT**

Application of electrical stimulation for wound healing enhancement is the subject of recent review papers (15,33-35). As mentioned in the previous section, the low-intensity electrical stimulation electricity has a positive impact on wound healing including increased both DNA and collagen synthesis, directed epithelial, fibroblast, and endothelial cell migration into wound sites, inhibited the growth of certain wound pathogens, and increased tensile strength of wound scar. Clinical reports are heavily dominated by case studies and case series. A number of randomized controlled trials have demonstrated efficacy of electrical stimulation for enhancing chronic wound healing, with the strongest evidence on treating pressure ulcers, but inconsistencies in the protocols by different investigators make it difficult to choose one regimen or electrical stimulation modality over another. Among the electrical stimulation modalities or electricity waveforms reported in the literature (Fig. 53.12), both electrical stimulation from direct current (DC, monopolar or monophasic) or alternating current (AC, bipolar or biphasic) have shown efficacy for wound healing enhancement, reflecting the complex nature of wound healing process that require the collaborative efforts of many different tissues and cell lineages and different electrical waveforms may affect different cellular pathways or cell responses (15).

Mehmandoust et al. (36) investigated the effects of anodal and cathodal electrical stimulation on wound healing. The results indicated that both cathodal and anodal stimulations increased the rate of wound closure. Following 12 days of treatment, a significant difference was observed in the percentage of the decrease in wound surface between all treatment and



**Figure 53.12** Electric stimulation modalities (electricity waveforms) for wound healing. There are reported evidences that both DC and AC electric stimulation enhance wound healing.

control groups ( $p < 0.05$ ). Ultimate tensile strength and stress increased in the anodal compared with the cathodal and control groups. The authors concluded that electrical stimulation, regardless of polarity regimen, benefits wound healing. However, anodal stimulation for the first three days and cathodal stimulation for the remaining days can lead to stronger repaired tissue.

Lee et al. (16) conducted a study to investigate the efficacy of ultralow microcurrent delivered by the electro-pressure regeneration therapy (EPRT) device for the management of chronic wounds. In this study, 23 patients with chronic skin ulcers and 2 with abdominal dehiscence that was present for an average of 16.5 months, who were not responsive to standard conservative treatment in a hospital setting, were treated with the EPRT device. Wounds were treated with direct current (maximum of 3 mA) of 1 polarity for 11.5 minutes and then with a current of the opposite polarity for another 11.5 minutes. Treatment was applied through ultralow microcurrents (in the mA to nA range) conducted through special wraps applied above and below the wound. The results revealed that 34.8% of cases achieved complete wound healing after an average of 45.6 hours of treatment, and 39.1% achieved  $\geq 50\%$  healing after an average of 39.7 hours of treatment. Several patients achieved significant results after one to two treatments. The EPRT device not only accelerated healing but also appeared to negate the effect of a person's age on wound healing.

Driban (37) conducted a clinical study to measure the transient electric changes in skin and muscle tissue immediately after trauma, with 11 participants (8 females, 3 males) with a mean age of  $65.18 \pm 11.36$  years undergoing total hip arthroplasty.

An incision approximately 10 cm distal to the posterior superior iliac spine extended distally over the greater trochanter and along the lateral limb. The incision was completed in two cuts: (i) skin and subcutaneous fat and (ii) muscle tissue.

Three measurement sessions were performed with an electrometer before and after a skin incision and after a muscle incision. Potential differences and current intensity were measured immediately after acute trauma to determine the transient electric changes associated with soft tissue injury. The electric potentials were significantly more negative after the skin incision and skin plus muscle incision. Current intensity changed significantly after the skin plus muscle incision. It was concluded that soft tissue trauma generated negative transient electric changes.

## TISSUE ENGINEERING

Low-intensity biomimetic electricity has been shown to improve tissue regeneration. In a recent review on regenerative medicine, Levin (38) pointed out that endogenous ion flows serve as key epigenetic regulators of cell behavior. Bioelectric signaling involves feedback loops, long-range communication, polarity, and information transfer over multiple size scales. Understanding the roles of endogenous voltage gradients, ion flows and electric fields will contribute to the basic understanding of numerous morphogenetic processes and the means by which they can robustly restore pattern after perturbation. Many researchers have investigated the use of low-level electricity to mimic bioelectricity to regenerate human tissues for tissue engineering applications (39–42). Tandon et al. (43) reported an experimental methodology for tissue engineering of synchronously contractile cardiac constructs by culturing cardiac cells with the application of pulsatile electrical fields designed to mimic those present in the native heart. Tissue culture is conducted in a customized chamber built to allow for cultivation of (i) engineered three-dimensional (3D) cardiac tissue constructs, (ii) cell monolayers on flat substrates, or (iii) cells on patterned substrates. This approach also allowed for analysis of the individual and interactive effects of pulsatile electrical field stimulation and substrate topography on cell differentiation and assembly. The experimental protocol was designed to allow for delivery of predictable electrical field stimuli to cells, monitoring environmental parameters, and assessment of cell and tissue responses. Engineered constructs that were electrically stimulated during culture demonstrate a remarkable level of ultrastructural differentiation, comparable in several respects with that of native myocardium.

Collagen synthesis in heart tissue was reported to increase with 50  $\mu\text{A}$ , but not with 100  $\mu\text{A}$  electric current. Mueller et al. (44) investigated the improvement of cardiac function by unloading with a cardiac assist device, and found that it mainly depends on the duration of heart failure. Patients with a short history of heart failure (approximately <5 years) show improvement due to reverse remodeling of the cardiomyocytes and in particular of the collagen composition of the extracellular matrix. One reason why patients with long-term heart failure (approximately >5 years) do not show significant cardiac function improvement is that the collagen composition of the extracellular matrix is then insensitive to mechanical unloading.

To examine whether microcurrent can also influence the collagen synthesis in the myocardium, the effect of microcurrent application on collagen synthesis of adult cardiomyocytes was investigated (45). The results suggest that microcurrent is able to modulate the synthesis of collagen. In dependency of the current magnitude collagen I can be up- or downregulated. Collagen I is responsible for the stiffness and the degree of dilatation of the heart.

## MICROCURRENT THERAPY FOR PAIN AND OTHER TREATMENTS

Microcurrent electrical therapy represents a significant improvement in rapid pain control and acceleration of healing (46,47). It uses current in the microampere range, 1000 times less than that of TENS and below sensation threshold. The pulse width or length of time that the current is delivered with a microcurrent device is much longer than previous technologies. A typical microcurrent pulse is about 0.5 seconds, which is 2500 times longer than the pulse in a typical TENS unit and a good microcurrent unit has approximately 10 times the electronic circuitry of a TENS unit. Unlike TENS, MET is usually administered through hand-held probes positioned so that current flows between them, through the painful area, for 10 seconds. Pain control following painful orthopedic procedures such as total knee arthroplasty is an ongoing challenge, as current pain management techniques often result in under-medication and/or complications.

Microampere current provides physiologic current flow and has been used in the treatment of some pain syndromes. McMakin (48) reported an uncontrolled retrospective analysis of patients receiving microcurrent treatment for fibromyalgia following cervical spine trauma, subjective pain scores are utilized as a primary outcomes measure. Accompanying changes in inflammatory cytokines are examined in a subgroup of the same patient population to test the hypothesis that microcurrent treatment produces substantial measurable objective and subjective outcomes supporting the efficacy of this treatment.

In this retrospective study based on analysis of subjective visual analogues scale (VAS) pain scores for 54 patients, symptoms of fibromyalgia following cervical spine trauma were successfully treated with microampere current. In a subgroup of the same patients, subjective pain improvement scores were accompanied by substantial reduction in serum levels of the inflammatory cytokines IL-1, IL-6, and TNF- $\alpha$ , and the neuropeptide substance P.  $\beta$ -Endorphin release and increases in serum cortisol were also observed in these patients during the same treatment period. The subjective outcomes scores in conjunction with biological markers for pain and pro-inflammatory cytokines observed in response to this treatment protocol are important preliminary findings. On the basis of the observations reported in this analysis, controlled prospective clinical studies to evaluate the clinical efficacy of microcurrent treatment of FMS associated with cervical spine trauma are warranted.

El-Husseini et al. (49) reported a study designed to test the effect of the microcurrent skin patch on pain relief in patients following total knee arthroplasty. Wound healing was better with the application of the microcurrent skin patch: grade 1 wounds were observed in 50% of the patients of the microcurrent skin patch group as compared to 8.3% in control group. The total drain volume was lower in patients of the microcurrent skin patch group compared to the controls. None of the patients indicated that they wished to discontinue microcurrent skin patch therapy. This pilot study shows that microcurrent skin patch therapy led to better pain control with a markedly lower need for tramadol as compared to the control group. This better pain control was accompanied by a better healing of the wound and a lower drain volume.

Cranial electrotherapy stimulation (CES), a noninvasive technique that delivers a microcurrent to the brain via ear clip electrodes, has been shown to effectively treat several neurological and psychiatric disorders. Tan et al. (50) reported a

clinical study using CES to treat pain associated with spinal cord injury (SCI). Treatments for chronic pain in persons with SCI have been less than effective. This study examined the effects of daily one-hour active CES or sham CES treatment (randomly assigned) for 21 days on pain intensity and interference with activities in 38 males with SCI. The active CES group (adjustable electric current: 100–500  $\mu\text{A}$ ) reported significantly decreased daily pain intensity compared with the sham CES group. Additionally, the active CES group reported significantly decreased pain interference in contrast to the nonsignificant decrease in the sham CES group. These results suggest that CES can effectively treat chronic pain in persons with SCI.

Chronic low back pain associated with myofascial trigger point activity has been historically refractory to conventional treatment. McMakin (51) reported that a case review on microcurrent therapy for 22 patients with chronic low back myofascial pain, of 8.8 years average duration, was presented. Following treatment with frequency-specific microcurrent, a statistically significant 3.8-fold reduction in pain intensity was observed using a visual analog scale. This outcome was achieved over an average treatment period of 5.6 weeks and a visit frequency of one treatment per week. When chronic pain exceeded five years, there was a trend toward increasing frequency of treatment required to achieve the same magnitude of pain relief. In 90% of these patients, other treatment modalities including drug therapy, chiropractic manipulation, physical therapy, naturopathic treatment, and acupuncture had failed to produce equivalent benefits. The microcurrent treatment was the single factor contributing the most consistent difference in patient-reported pain relief.

### ANTIMICROBIAL ACTIVITY

Low-intensity electricity was known to have inhibitive or killing activity on microorganisms, and was also known to prevent attachment of bacterial biofilm to medical implants or to cause detachment of bacterial biofilm.

The bioelectric effect, in which electric fields are used to enhance the efficacy of biocides and antibiotics in killing biofilm bacteria, has been shown to significantly reduce the amount of antibacterial agents needed to kill biofilm bacteria to levels very close to that needed to kill planktonic (free floating) bacteria of the same species. Costerton et al. (52) reported that biofilm bacteria are readily killed by an antibiotic on all areas of the active electrodes and on the surfaces of conductive elements that lie within the electric field but do not themselves function as electrodes. Considerations of electrode geometry indicate that very low ( $<100 \mu\text{A}/\text{cm}^2$ ) current densities may be effective in this electrical enhancement of antibiotic efficacy against biofilm bacteria, and flow experiments indicate that this bioelectric effect does not appear to depend entirely on the possible local electrochemical generation of antibacterial molecules or ions. These data are expected to facilitate the use of the bioelectric effect in the prevention and treatment of device-related bacterial infections that are caused by bacteria that grow in biofilms and thereby frustrate antibiotic chemotherapy.

Del Pozo et al. (53) recently reviewed the bioelectric effect and bacterial biofilms. Bacteria growing in biofilms cause a wide range of human infections. Biofilm bacteria are resistant to antibiotics at levels 500 to 5000 times higher than those

needed to kill nonbiofilm bacteria. In vitro experiments have shown that electric current can enhance the activity of some antimicrobial agents against certain bacteria in biofilms. Direct electrical current has already been safely used in humans for fracture healing. Application of direct electric current with antimicrobial chemotherapy in humans could theoretically abrogate the need to remove the device in device-related infections, a procedure associated with substantial morbidity and cost.

Bacterial biofilms are believed to be a major factor in problems of ineffective sterilization often encountered in clinics, hospitals, and industrial processes. There have been indications that the addition of a relatively low-intensity direct current electric field with the sterilant used to combat the biofilm greatly increases the efficacy of the sterilization process. The results of the experiments reported by Wellman et al. (54) support the concept of the "bioelectric effect" as reported by Costerton's work (52). With a current of 1 mA flowing through the chamber containing bacterial biofilm, an increase in the killing of the bacteria of about 8 log orders was observed at the end of 24 hours (compared with the control with the same amount of antibacterial agent but no current). It was also confirmed that the current alone does not affect the biofilm and that there appear to be optimum levels of both the current and the sterilant that are needed to obtain the maximum effect.

Kalinowski et al. (55) described the use of low voltage direct current as a fungicidal agent for treating onychomycosis. Onychomycosis, most commonly caused by two species of dermatophyte fungi—*Trichophyton rubrum* and *Trichophyton mentagrophytes*, is primarily treated with regimens of topical and systemic antifungal medications. This study was undertaken to evaluate in vitro the efficacy of low-voltage direct current as an antifungal agent for treating onychomycosis. Agar plate cultures of *T. rubrum* and *T. mentagrophytes* were subjected to low-voltage direct current electrostimulation, and antifungal effects were observed as zones in the agar around the electrodes lacking fungal growth. Zones devoid of fungal growth were observed for *T. rubrum* and *T. mentagrophytes* around anodes and cathodes in a dose-dependent manner in the current range of 500  $\mu\text{A}$  to 3 mA. Low-voltage direct current electrostimulation has great clinical potential for the treatment of onychomycosis and perhaps other superficial maladies of fungal etiology.

Bolton et al. (56) reported that positive carbon-containing electrodes conveying 5  $\mu\text{A}$  or more of constant direct current per  $\text{cm}^2$  showed bactericidal activity on intact back skin of 13 human subjects. This effect increased with the duration of stimulation up to a total surface bacterial kill at 20 hours. When total current and current density were varied independently on 16 sites on the backs of eight subjects, the effect was dependent on current density, not on total current. Electrodes driven by similar voltages but which removed the electrochemical reaction from inoculated sites on the backs of three subjects failed to reduce the numbers of colony-forming units as compared with those sampled from control sites. This showed the bactericidal effect to be electrochemical in origin, probably mediated by local acidity generated at the surface of the positive carbon-containing electrodes. With an adhesive tape stripping technique on three sites on each of six subjects, it was determined that the effect extended into the epidermis of the human back. No effect was observed beneath negative or control electrodes under the same conditions.

## BIOMIMETIC ELECTRICITY FOR DERMATOLOGICAL APPLICATIONS

Electrical stimulation of the body used in electrotherapy, and iontophoretic drug delivery are typically achieved by the use of battery-powered electronic medical devices, which are often complicated and cumbersome to use. Other means of applying biomimetic electricity to the body conveniently and effectively are therefore highly desirable. Physiological level of biomimetic electricity may be derived from the electrochemical reactions of a galvanic couple, a pair of dissimilar metals electrically connected together in contact with a conductive electrolyte medium. Galvanic current is the electron flow that runs between the two dissimilar metals of a galvanic couple and the surrounding electrolyte solution. The theory of galvanic couple's electrochemical reactions is well known and is the underlying principle for batteries/electrochemical cells. Galvanic electrochemical reactions have been used as the electrical power source in commercial medical devices based on a zinc-silver/silver chloride galvanic couple for transdermal iontophoretic drug delivery (57,58). Electrochemical reactions on the electrode surfaces of the galvanic couple concurrently generate zinc ions on zinc anode via oxidation of metallic zinc, and hydrogen gas on the cathode via reduction of hydrogen ions in the water (59). We are reporting here a new method of delivering biomimetic electricity for anti-inflammatory effects by using fine particles of zinc-copper galvanic couple made of pure metallic zinc metal partially coated with metallic copper (bimineral complex) with a coplanar electrode configuration for the zinc anode and copper cathode similar to that reported by Doig and Flewitt (60).

### Biomimetic-Electricity Delivery Systems Containing Bimineral Complex

On the basis of the insights of bioelectricity for wound healing, a microelectricity delivery system was reported using unique combination of elemental zinc and copper to generate biological levels of electricity when in contact with conductive media such as physiological fluid, moisturizer, etc. The results demonstrated that the intensity and duration of the electricity can be adjusted through bimineral complex combination, ratio, and particle size.

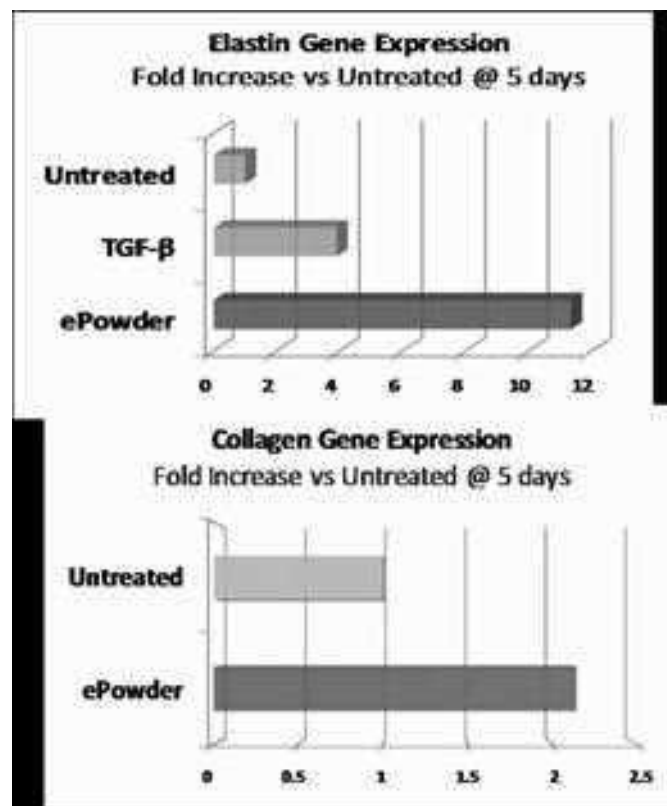
### In Vitro Biological Responses

#### *Anti-Inflammatory Activity*

In several in vitro cytokine studies, treatment with the bimineral complex significantly reduced release of pro-inflammatory cytokines from activated human T cells and inhibited release of cytokines from keratinocytes and macrophages exposed to bacteria (61). Furthermore topical application of a lotion containing the bimineral complex reduced the UV-induced damage to human skin equivalents. Taken together these results demonstrate that biomimetic electricity reduces inflammatory responses and therefore may protect skin from the numerous external aggressions encountered daily by skin.

#### *Dermal Extracellular Matrix Production*

The elemental bimineral complex, which produces physiological levels of electricity, was also evaluated for its possible effects on dermal extracellular matrix (62). Fresh human abdominal skin samples were obtained from surgical procedures and tested as human skin explants maintained in a culture medium. Human skin explants were topically treated with this bimineral complex, once daily for seven days, and the



**Figure 53.13** Effect of bimineral complex on upregulation of collagen and elastin expressions.

effect on elastin and collagen was evaluated. LUNA elastin staining showed that treatment with the bimineral complex increased the elastin fiber network, as compared to untreated controls. QPCR analysis documented an increase in elastin and collagen expression in the bimineral complex-treated skin samples (Fig. 53.13). The results suggest that this bimineral complex may be effective in restoring the integrity and functionality of dermal extracellular matrix, and in particular of elastic fibers, suggesting its cosmetic use in the aged skin.

#### *Melanogenesis Inhibition*

To examine the effect of electric field modulation on melanogenesis, pigmented epidermal equivalents were topically treated with a proprietary elemental bimineral complex that produces biomimetic electricity, once daily for seven days (63). F&M staining showed a significant decrease in melanin deposition in epidermal equivalents treated with the bimineral complex, compared to untreated control. This reduction in melanin deposition was also observed in epidermal equivalents treated with a cosmetic formula containing the bimineral complex. Exploring the mechanism of this biomimetic electricity-induced depigmentation, it was shown that there was no direct inhibitory activity against phagocytic activity of keratinocytes. Interestingly, the bimineral complex inhibited tyrosinase and tyrosinase-related protein 1 (TRP-1) expression using mouse melanoma B16 cells, as analyzed by TYR and TRP-1 promoter-luciferase reporter assays. Using cultured human skin explants, it was confirmed that melanin content and TYR mRNA are reduced by the

exposure to the bimineral complex. These data support the potential of using biomimetic electricity generated by an elemental bimineral complex for skin-lightening applications.

### Clinical Safety and Tolerability

Several clinical and preclinical safety studies were conducted (64).

Clinical safety was assessed through human repeat insult patch tests (RIPT). Five RIPT studies were performed on topical compositions containing various concentrations of the bimineral complex. Four RIPT studies were conducted in a predominantly Caucasian population in the United States, and one study was conducted in an Asian population in Thailand. Combined, over 800 healthy subjects completed the clinical safety studies. Results show that none of the topical compositions induced dermal sensitization.

In addition, a topical composition containing the bimineral complex was evaluated versus placebo for its potential to induce dermal and ocular irritation in a human skin model (EpiDerm™, MatTak, Ashland, Massachusetts, U.S.) and human corneal model (EpiOcular™, MatTak, Ashland, Massachusetts, U.S.). Results show that the bimineral complex has low potential for skin and eye irritation.

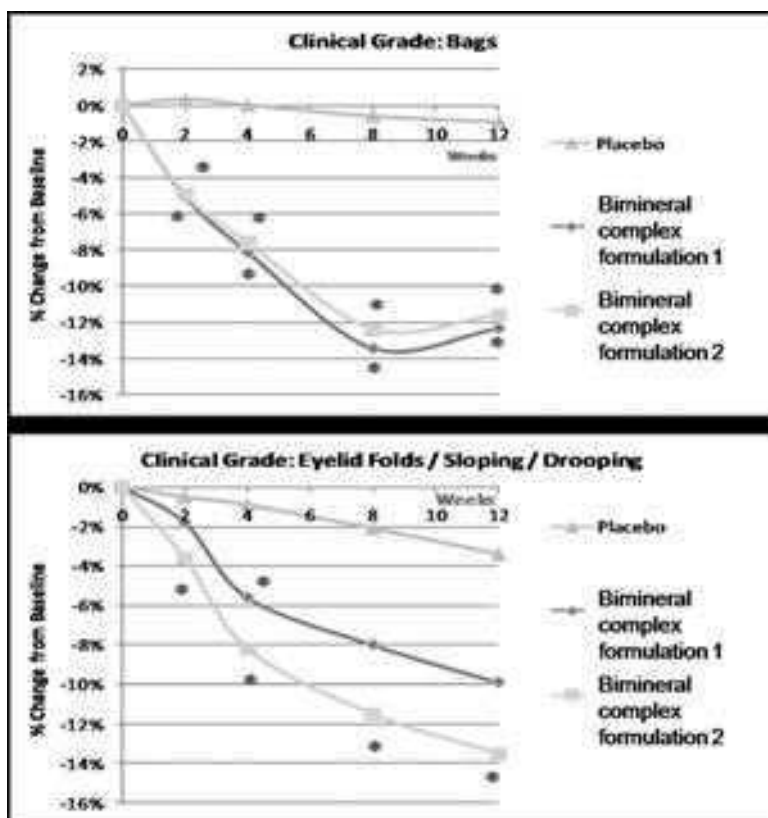
Topical compositions containing the bimineral complex have been evaluated for their tolerability and efficacy in reducing the signs of facial and periorbital photoaging in over eight clinical studies spanning populations in three countries, the United States, France, and Singapore. The bimineral compositions were shown to be mild and well tolerated in all populations studied.

### Clinical Efficacy for Skin Antiaging

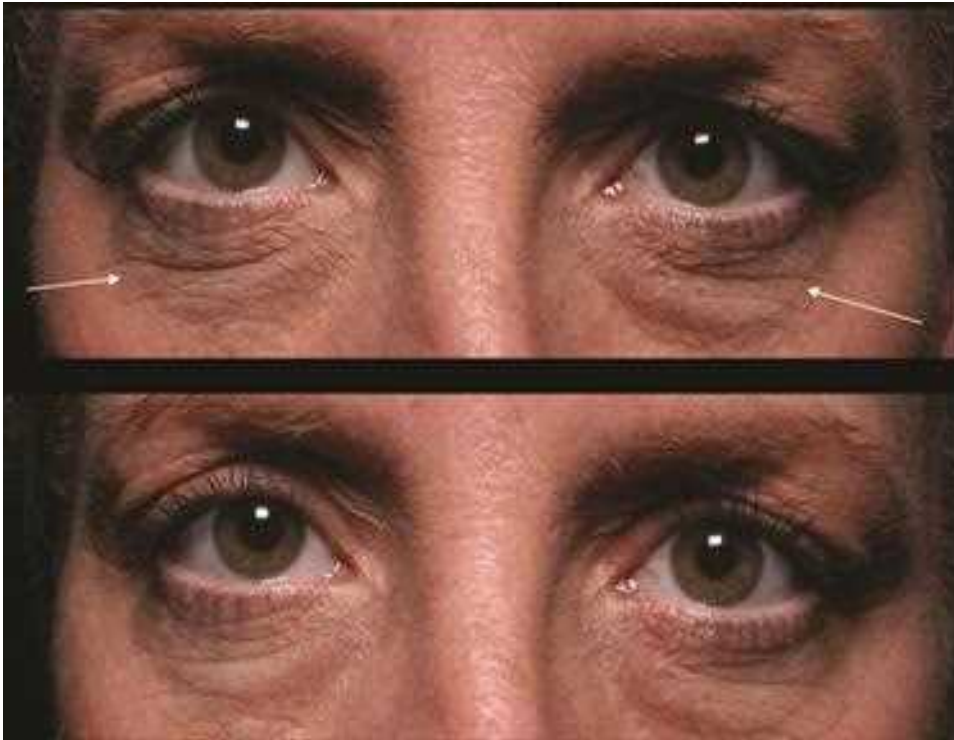
#### Twelve-Week Randomized Placebo-Controlled Antiaging Study

The clinical signs of photoaging are a persistent concern for many patients. Intrinsic factors and cumulative exposure to extrinsic factors such as UV lead to the development of skin laxity, fine lines, wrinkles, hyperpigmentation, and sallowness. A 12-week, double-blind, placebo-controlled clinical study was performed to evaluate the efficacy and tolerability of a topical composition containing the bimineral complex in reducing the clinical signs of facial photoaging, including the delicate periorbital area (65). The study consisted of three treatment groups: (i) placebo moisturizer, (ii) bimineral complex moisturizer, and (iii) bimineral complex moisturizer with activator. The study population consisted of 94 healthy women, aged 40 to 65, with Fitzpatrick Skin Type of II to IV and mild to moderate photoaging. Subjects applied the bimineral complex twice daily, in the morning and evening. Evaluations included clinical grading of safety and efficacy parameters, high-resolution digital imaging, and subject self-assessments. All measures were taken at baseline and weeks 2, 4, 8, and 12.

Both treatment groups using the bimineral complex showed statistically significant ( $p < 0.05$ ) clinical improvement versus placebo and versus baseline starting as early as week 2 in several parameters and continued to improve versus placebo through week 12. The bimineral complex performed significantly ( $p < 0.05$ ) better than placebo and baseline in overall appearance, drooping eyelids, under-eye bags, under-eye wrinkles, cheek wrinkles, pigmentation, radiance, fine lines, and global lifting/firming. Figure 53.14 shows significant improvement of 12-week clinical grades for under-eye bag and drooping eyelids. Figure 53.15 shows a pair of sample clinical images after two



**Figure 53.14** Twelve-week randomized placebo-controlled clinical results of eye conditions after topical administration of bimineral complex.



**Figure 53.15** Sample images of clinical results after two weeks of twice-daily topical treatment of a bimineral complex topical formulation.

weeks of topical treatment of a formulation containing bimineral complex. There were no adverse events related to the treatments in this clinical study, and the bimineral complex and placebo were all shown to be well tolerated throughout the 12-week study.

#### *Four-Week Antiaging Study Combining Bimineral Complex with Natural Extracts*

Natural ingredients are increasingly being recognized for their skincare benefits as they continue to be shown to have various *in vitro* and *in vivo* activities. Preclinical and initial clinical data have shown the potential of a bimineral complex consisting of a proprietary blend of elemental zinc and copper that generates biomimetic signals for improving photoaging, and *in vitro* data has also suggested the antiaging benefits of a combination of dill and blackberry leaf extract. A clinical study was performed using a regimen of a bimineral complex gel and a dill-blackberry leaf extract lotion with SPF 30 to evaluate its ability to rapidly improve multiple signs of facial photoaging, while being mild to the skin (66). Thirty healthy female subjects, between the ages of 30 to 55, with moderate facial photoaging, exhibiting mottled hyperpigmentation, skin roughness, laxity, and fine wrinkling completed this four-week study. Patients applied the two-product system once per day in the morning. Clinical evaluations, self-assessments, and instrumental analysis demonstrated this two-product regimen's multiple skin benefits throughout the study. Clinical evaluations indicated significant improvements ( $p < 0.05$ ) in facial skin clarity, smoothness, and overall photoaging after two weeks of use. Significant improvements ( $p < 0.05$ ) in the appearance of mottled hyperpigmentation, firmness, and fine wrinkling were observed by the four-week time point. Patients also perceived significant ( $p < 0.05$ ) improvements in skin tone, brightness, and textural parameters as early as after two weeks of use. Digital photographs also confirmed

improvements in various overall photoaging parameters. In conclusion, this clinical study demonstrated that a regimen of a bimineral complex gel and a dill-blackberry leaf extract lotion with SPF 30 was effective in improving the overall signs of facial photodamage including improvements in fine lines and wrinkles, tone, pigmentation, and texture, while being mild and gentle to the skin.

#### *Four Weeks Laxity Clinical Study*

We have evaluated the clinical efficacy of a facial treatment regimen consisting of this bimineral complex plus a facial moisturizer in a four-week double-blinded controlled study (67). Thirty subjects with mild to moderate signs of photodamage and moderate skin laxity completed the study. The patients applied the regimen once per day in the morning. Clinical evaluations, self-assessments, and instrumental analysis demonstrated this two-product regimen's multiple skin benefits throughout the study. The facial treatment was particularly effective in improving skin firmness and laxity ( $p < 0.05$ ), while also providing significant improvements in overall photodamage. Patients also perceived significant ( $p < 0.05$ ) improvements in overall signs of photodamage and lifting. The regimen was well tolerated.

#### *Antiaging Focusing on Eye Areas*

The first signs of skin aging often occur in the delicate skin of the periorbital area. Characteristic signs associated with chronological and photoaging in the eye area include fine lines and wrinkles, dark circles and bags under the eye, and puffiness and laxity in both the upper and lower eyelids. Three clinical studies were conducted to evaluate efficacy and tolerability in reducing signs of photoaging in the periorbital area for immediate and continuous benefits.

The first study focused on immediate benefits after a single application of the bimineral complex (68). Twenty-two females, ages 25 to 45 completed this double-blind, benchmark controlled study. To enroll at baseline, subjects must experience at least one of the following conditions of mild to moderate severity based on expert grading: under-eye bags, puffiness, dark circles, lines, and wrinkles. Clinical imaging and subject self-assessments were taken at baseline, 20 to 30 minutes post-product application, and 3 hours post-product application. Study results show that the bimineral complex demonstrated visible, measurable improvement ( $p < 0.05$ ) at 20 to 30 minutes postapplication and continued to show improvement ( $p < 0.05$ ) at 3 hours in parameters such as under-eye puffiness, bags, and fine lines.

The second clinical study was a placebo-controlled, double-blind study to evaluate the immediate and continuous effects of the bimineral complex over an eight-week period (68). One-hundred and twenty women, ages 40 to 65 with mild to moderate photo-aging at baseline completed this study. Clinical grading, clinical imaging, and subject self-assessments were performed at baseline, immediately after product application and after 1, 2, 4, and 8 weeks of product use. Clinical grading immediately after the first product application shows that the treatments containing the bimineral complex have significant ( $p < 0.05$ ) improvement versus placebo in under-eye dark circles, under-eye bags, skin radiance, and overall photo-damage.

In both studies, the bimineral complex showed immediate and lasting improvement versus baseline, and all compositions were well-tolerated.

A third study was performed on 34 healthy Caucasian women volunteers aged between 35 and 60 years old with wrinkles and/or fine lines at the eye contour area, dark circles, and puffiness (69). Product was applied for eight weeks, once a day, in the morning. Clinical grading of the signs of aging was done at baseline, immediately after the first application, then after one week, four weeks, and eight weeks of application. Wrinkles, tone, and sagging were assessed by an expert grader around the eyes using visual analog scales. A paired Student *t*-test was performed versus baseline and the confidence level considered was  $p < 0.05$ .

Immediately after the first application, all the parameters assessed were significantly improved versus baseline ( $p < 0.05$ ). The product improved bags and dark circles (respectively +32% and +21%) as well as wrinkles (crow's feet: +24%, under eye: +22%), sagging (sloping eyelids: +20.29%, folds on the eyelids: 17%), and skin complexion (radiance: +17%, yellowish complexion: +52%). Some of changes were still increasing after one week of application. The tested product containing the new biomimetic signaling technology was demonstrated to be efficacious from the first week of use.

## SUMMARY

Bioelectricity is an emerging science presenting a new opportunity for medical therapies. Basic research suggests that ultra-low electrical fields can enhance tissue healing, ATP production, antimicrobial activities, inflammation reduction, pain relief, and improving dermatological conditions. However, specific mechanisms of action remain unclear. The application of a specific low-intensity electricity or biomimetic electricity for the medical applications warrants a new area for exploration.

## ACKNOWLEDGMENT

The authors would like to extend deep and sincere gratitude to many colleagues at Johnson and Johnson for their contributions and support to this work.

## REFERENCES

- Slack JMW. The spark of life: electricity and regeneration. *Sci STKE* 2007; 405:54.
- McCaig CD, Rajnicek AM, Son B, et al. Controlling cell behavior electrically: current views and future potential. *Physiol Rev* 2005; 85:943–978.
- Reily JP. Applied Bioelectricity—From Electrical Stimulation To Electrotherapy. Springer, 1998:5–6.
- Watson T. The Role of Electrotherapy in Contemporary Physiotherapy Practice. *Manual Therapy* 2000; 5:132–141.
- Robertson V, Ward A, Low J, et al. *Electrotherapy Explained—Principles and Practice*. 4th ed. London, UK: Butterworth Heinemann Elsevier Ltd., 2006.
- Subramony JA, Sharma A, Phipps JB. Microprocessor controlled transdermal drug delivery. *Intern J Pharm* 2006; 317:1–6.
- Johnson MI. Transcutaneous electrical nerve stimulation (TENS) and TENS-like devices: do they provide pain relieve? *Pain Review* 2001; 8:121–158.
- Rai R, Srinivas CR. Iontophoresis in dermatology. *Indian J Dermatol Venereol Leoprol* 2005; 71:236–241.
- Chen CJ, Yu HS. Acupuncture, electrostimulation, and reflex therapy in dermatology. *Dermatol Ther* 2003; 16:87–92.
- Cheng N, Van Hoof H, Bockx E, et al. The effect of electric current on ATP generation, protein synthesis, and membrane transport in rat. *Clin Orthop Relat Res* 1982; 171:264–272.
- Chapman-Jones D, Hill D. Novel microcurrent treatment is more effective than conventional therapy for chronic Achilles tendinopathy randomised comparative trial. *Physiotherapy* 2002; 88(8):471–480.
- Marx JL. Electric current may guide development. *Science* 1981; 211:1147–1149.
- Zhao M, Song B, Pu J, et al. Electrical signals control wound healing through phosphatidylinositol-3-OH kinase- $\gamma$  and PTEN. *Nature* 2006; 442:457–460.
- Huttenlocher A, Horwitz AR. Wound healing with electric potential. *N Engl J Med* 2007; 356:303–304.
- Ojingwa JC, Isseroff RR. Electric stimulation of wound healing. *J Invest Dermatol* 2003; 121:1–12.
- Lee BY, Wendell K, Al-Waili N, et al. Ultra-low microcurrent therapy: a novel approach for treatment of chronic resistant wounds. *Adv Ther* 2007; 24:1202–1209.
- Driban JB, Swanik CB, Huxel KC, et al. Transient electric changes immediately after surgical trauma. *J Athl Train* 2007; 42:524–529.
- Hodges SD, Jason C, Humphreys SC. Use of electrical bone stimulation in spinal fusion. *J Am Acad Orthop Surg* 2003; 11:81–88.
- McCaig CD, Zhao M. Physiological electrical fields modify cell behaviour. *Bioessays* 1997; 19:819–826.
- Jennings J, Chen D, Feldman D. Transcriptional response of dermal fibroblasts in direct current electric fields. *Bioelectromagnetics* 2008; 29:394–405.
- Oishi M, Onesti ST. Electrical bone graft stimulation for spinal fusion: a review. *Neurosurgery* 2000; 47:1041–1056.
- Song B, Zhao M, Forrester J, et al. Nerve regeneration and wound healing are stimulated and directed by an endogenous electrical field in vivo. *J Cell Sci* 2004; 117:4681–4690.
- Brighton CT, Wang W, Seldes R, et al. Signal transduction in electrically stimulated bone cells. *J Bone Joint Surg* 2001; 83:1514–1523.
- Pullar CE, Isseroff RR. Cyclic AMP mediates keratinocyte directional migration in an electric field. *J Cell Sci* 2005; 118:2023–2034.
- Sillman AL, Guang DM, Barboud B, et al. Human dermal fibroblasts do not exhibit directional migration on collagen I in direct-current electric fields of physiological strength. *Exp Biol* 2003; 12(4):396–402.

26. Brown MJ. Electric field-directed fibroblast locomotion involves cell surface molecular reorganization and is calcium independent. *J Cell Biol* 1994; 127:117–128.
27. Jaffe LF, Nuccitelli R. An ultrasensitive vibrating probe for measuring extracellular currents. *J Cell Biol* 1974; 63:614–628.
28. Nuccitelli R, Nuccitelli P, Ramlatchan S, et al. Imaging the electric field associated with mouse and human skin wounds. *Wound Rep Reg* 2008; 14:432–441.
29. Reid B, Nuccitelli R, Zhao M. Non-invasive measurement of bioelectric current with a vibrating probe. *Nat Protoc* 2007; 2(3): 661–669.
30. Nuccitelli R, Nuccitelli P, Li C, et al. The Electric Field at Human Skin Wounds Declines Sharply with Age. 18th Annual Meeting of the Wound Healing Society, San Diego, CA, April 24–27, 2008.
31. Grahn JC, Reilly DA, Nutccitelli RL, et al. Melanocytes do not migrate directionally in physiological DC electric fields. *Wound Rep Reg* 2003; 11:64–70.
32. Lin Y-L, Moolenaar H, van Weeren PR, et al. Effect of micro-current electrical tissue stimulation on tenocyte in culture. *Am J Vet Res* 2006; 67:271–276.
33. Nuccitelli R. A role for endogenous electric fields in wound healing. *Curr Top Dev Biol* 2004; 58:1–24.
34. Kloth LC. Lower Extremity Wounds, Electrical stimulation for wound healing: a review of evidence from in vitro studies, animal experiments, and clinical trials. *Int J Low Extrem Wounds* 2005; 4(1):23–44.
35. Balakatounis KC, Angoules AG. Low-intensity electrical stimulation in wound healing: review of the efficacy of externally applied currents resembling the current of injury, open access. *J Plast Surg* 2008; 8(e28):283–291.
36. Mehmandoust FG, Torkaman G, Froozabadi M, et al. Anodal and cathodal pulsed electrical stimulation on skin wound healing in guinea pigs. *J Rehabil Res Dev* 2007; 44(4):611–618.
37. Driban JB. Transient electric changes immediately after surgical trauma. *J Athl Train* 2007; 42(4):524–529.
38. Levin M. Bioelectric mechanisms in regeneration: unique aspects and future perspectives. *Semin Cell Dev Biol* 2009; 20(5):543–556.
39. Radisic M, Park H, Gerecht S, et al. Biomimetic approach to cardiac tissue engineering. *Phil Trans R Soc B* 2007; 362:1357–1368.
40. Pedrotty DM, Koh J, Davis BH, et al. Engineering skeletal myoblasts: roles of three-dimensional culture and electrical stimulation. *Am J Physiol Heart Circ Physiol* 2005; 288:1620–1626.
41. Ghasemi-Mobarakeh EL, Molamma P, Prabhakaran MP, et al. Electrical stimulation of nerve cells using conductive nanofibrous scaffolds for nerve tissue engineering. *Tissue Eng Part A* 2009; 15(11):3605–3619.
42. Ting Y, Ya L, Hai-Tao W, et al. Influence of pulse electrical stimulation on osteoblast proliferation and osteogenic activity on the surface of modified nano-hydroxyapatite/poly(lactide-co-glycolide) composite material. *J Clin Rehab Tissue Eng Res* 2009; 13(16):3065–3069.
43. Tandon N, Cannizzaro C, Chao PG, et al. Electrical stimulation systems for cardiac tissue engineering. *Nat Protoc* 2009; 4(1):155–173.
44. Mueller J, Kapeller B, Wallukat G, et al. Changes of the collagen composition in the heart induced by microcurrent application. A future approach to heart failure treatment? *J Heart Lung Transplant* 2005; 24(2S) 197:S106–S107.
45. Mueller J, Kapeller B, Macfelda K. Recovery of heart failure by normalization of the cardiac extracellular matrix after microcurrent application. *J Heart Lung Transplant* 2006; 24(2) supplement 1, 133:S91.
46. Mercola JM, Kirsch DL. The basis for microcurrent electrical therapy in conventional medical practice. *J Adv Med* 1995; 8(2): 107–120.
47. Kirsch DL. Microcurrent electrical therapy (MET): a tutorial. *Pract Pain Manage* 2006; 6(7):59–64.
48. McMakin CR. Cytokine changes with microcurrent treatment of fibromyalgia associated with cervical spine trauma. *J Bodywork Move Ther* 2005; 9:169–176.
49. El-Husseini T, El-Kawy S, Shalaby H, et al. Microcurrent skin patches for postoperative pain control in total knee arthroplasty: a pilot study. *Int Orthop* 2007; 31(2):229–233.
50. Tan G, Rintala DH, Thornby JI, et al. Using cranial electrotherapy stimulation to treat pain associated with spinal cord injury. *J Rehabil Res Dev* 2006; 43(4):461–474.
51. McMakin CR. Using cranial electrotherapy stimulation to treat pain associated with spinal cord injury. *J Bodywork Move Ther* 2004; 8:143–153.
52. Costerton JW, Ellis B, Lam K, et al. Mechanism of Electrical Enhancement of Efficacy of Antibiotics in Killing Biofilm Bacteria. *Antimicrob Agents Chemother* 1994; 38(12):2803–2809.
53. Del Pozo JL, Rouse MS, Patel R. Bioelectric effect and bacterial biofilms—a systematic review. *Int J Artif Organs* 2008; 31(9): 786–795.
54. Wellman N, Fortun SM, McLeod BR. Bacterial biofilms and the bioelectric effect. *Antimicrob Agents Chemother* 1996; 40(99): 2012–2014.
55. Kalinowski DP. Low-voltage direct current as a fungicidal agent for treating onychomycosis. *J Am Podiatr Med Assoc* 2004; 94(6): 565–572.
56. Bolton L, Foleno B, Means B, et al. Direct-current bactericidal effect on intact skin. *Antimicrob Agents Chemother* 1980; 18(1): 137–141.
57. Chaturvedula A, Joshi DP, Anderson C, et al. In vivo iontophoretic delivery and pharmacokinetics and salmon calcitonin. *Intern J Pharm* 2005; 297:190–196.
58. Vranken JH, Dijkgraaf MGW, Kruis MR, et al. Iontophoretic administration of S(+)-ketamine in patients with intractable central pain: a placebo-controlled trial. *Pain* 2005; 118:224–231.
59. Zhang X. *Corrosion and Electrochemistry of Zinc*. New York: Plenum Press, 1996:32 & 51.
60. Doig P, Flewitt PEJ. A finite difference numerical analysis of galvanic corrosion for semi-infinite linear coplanar electrodes. *J Electrochem Soc* 1979; 126(12):2057–2063.
61. Sur PR, Lyte P, Garay M, et al. Biomimetic Electricity Generated by an Elemental Bi-mineral Complex Produces Anti-Inflammatory Activity, Poster No. 1618, Proceed Am Acad Derm, 2010.
62. Chen N, Hu Y, Rossetti D, et al. Biomimetic Electricity Generated by an Elemental Bi-mineral Complex Increases Extracellular Matrix Production in Human Skin Explants, Poster No. 1619, Proceed Am Acad Derm, 2010.
63. Chen N, Loy CJ, Hu Y, et al. Biomimetic Electricity Generated by an Elemental Bi-mineral Complex Inhibits Melanogenesis via Suppressing Tyrosinase Expression, Poster No. 1621, Proceed Am Acad Derm, 2010.
64. Chantalat J, Loy CJ, McCarthy T, et al. Safety and Tolerability of a Topical Bi-mineral Complex that Generates Biomimetic Signals, P1622 Poster, Proceed Am Acad Derm, 2010.
65. Chantalat J, Bruning E, Sun Y, et al. (Discussion Session), Biomimetic Signaling Technology Generated by a Bi-mineral Complex Demonstrates Efficacy in Reducing Clinical Photo-aging in a 12-Week Placebo-Controlled Study, Poster No. 304, Proceed Am Acad Derm, 2010.
66. Miller PD, Wallo W, Appa Y. Clinical Improvements in Facial Photo-Aging with Topical Application of a Biomimetic Mineral Complex and Naturals Extract Formulation, Poster No. 1638, Proceed Am Acad Derm, 2010.
67. Hornby SB, Miller D, Stephens T, et al. Facial moisturizer featuring biomimetic signaling technology from a bi-mineral complex reduces skin laxity, Poster No. 1625, Proceed Am Acad Derm, 2010.
68. Chantalat J, Bruning E, Sun Y, et al. Biomimetic Signaling Technology Generated by a Bi-mineral Complex Reduces Signs of Photo-aging in the Eye Area Poster No. 1624, Proceed Am Acad Derm, 2010.
69. Lanctin M, Roure R, Nkengne A, et al. A Cosmetic Product Containing Biomimetic Signaling Technology to Improve the Aging Signs in the Eye Area, Poster No. 1623, Proceed Am Acad Derm, 2010.



# Chemical peelings

Philippe Deprez

## INTRODUCTION

Many peeling formulas are actually available, many of them resulting from a more or less adequate combination of chemicals that aim usually to peel the skin and induce a skin rebuilding, an architectural restructuring. Some peelings consist of strongly destructive solutions, able to dissolve the full skin thickness; others are simply stimulating solutions with little destructive power, their application can induce a nearly invisible skin desquamation.

The difficulties of peeling procedures, the results, the inconveniences, the side effects are often directly linked to the depth reached by the acids.

Not much will be said about prepeel skin conditioning in this chapter, breaking a quasi-dogma. Indeed, there is a possible way to do peelings that make this prepeel strict conditioning not often necessary (1). I just use peeling formulas that usually penetrate evenly and that dramatically slow down the immediate postpeel inflammatory reaction, mainly responsible for post-inflammatory hyperpigmentations (PIH). The rest is a question of good indication (do not go too deep if not necessary) and practitioner's ability or experience.

## DEPTHS OF PEELINGS

I usually consider seven depths of peelings, as seen on the following graph (Fig. 54.1).

### Depth 1—Exfoliation: Very High Security (VHS)

The most superficial peel consists in a simple exfoliation of stratum corneum dead cells: it gives a good skin cleansing, a touch of better hydration. This hydration results in reality from removing the protective stratum corneum layer and the fingers are directly in contact with superficial keratinocytes. Keratinocytes are living cells (only the most superficial layers are near to the death), containing more water than stratum corneum cells.

#### *Main Type of Peels*

$\alpha$ -Hydroxy acids (AHAs) peels are mostly used for exfoliation purpose.

#### *Action Mode*

The activity of AHAs on the corneocytes seems to be secondary to an action on ionic charges, through an inhibition of enzymes involved in the formation of ionic links. For example, AHAs could compete with sulfates and phosphates at the level of sulfotransferases, phosphotransferases, or kinases involved in the formation of sulfated or phosphorylated mucopolysaccharides, glycoproteins, sterols, and lipids. This could produce a lower quantity of electrically negative groups on the surface of

keratinocytes and corneocytes and lower the adhesion forces with amines or basic aminated acids (electrically positive).

Basically, AHAs penetrate between cells, unsticking the proteins responsible for corneodesmosomes adhesivity (it is a noncovalent, electric link) and allowing the cells to separate from each other, inducing a desquamation. Since there is no strict chemical reaction during this process, AHAs are not much consumed and have to be neutralized. Rinsing with a basic solution stops their action.

#### *Clinical Signs*

Irritative erythema is usually the only visible sign.

#### *Desquamation*

Roughly, no desquamation is clinically seen.

#### *Risks and Problems*

Globally, this is not a risky depth. Main risks are a higher sensitivity to sun during some days and a higher risk of skin infections. Neutralization is the main problem: if too early, it gives no result; if too late, it could induce more side effects. We will see later that this problem can be avoided by using specific slow release and self-neutralizing AHA mixtures (Easy Phytic Solution).

### Depth 2—Intraepidermic Peel: VHS

The peel solution penetrates deeply into the epidermis, removing more cells; nevertheless, it does not touch any part of dermis or even of basal layer. The final touch of the skin is still more hydrated than in the case of a simple exfoliation, depth 1. After peel, living keratinocytes are suddenly directly exposed to air, sun, pollution, and dryness. They react, synthesizing more TNF- $\alpha$  (inducing a faster transformation of keratinocytes into corneocytes) and sending a message to the basal layer to stimulate the basal layer turnover and substitute the removed cells by new ones. At the same time, another message reaches the fibroblasts, responding to a stronger synthesis of all the dermal intercellular matrix.

Intraepidermic peels (depth 2) give better results than depth 1 peels and can be used for treating superficial epidermal melasma and many keratinization problems.

#### *Main Type of Peels*

AHA peels,  $\alpha$ -keto acids, trichloroacetic acid (TCA), resorcine peels, salicylic acid can be used.

#### *Action Mode*

We have roughly seen how AHAs work. TCA is a proteocoagulant chemical. When in contact with proteins, it coagulates them, modifying their tridimensional structures in a way that

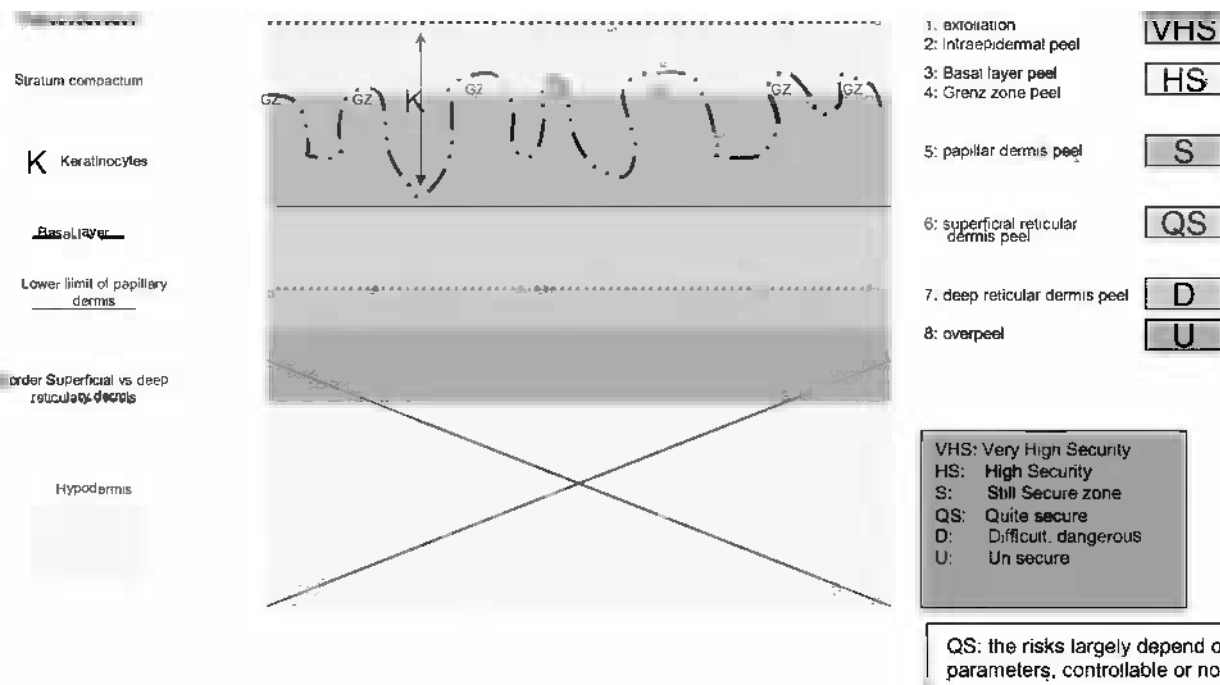


Figure 54.1 Graph showing the various possible depths of peelings.



Figure 54.2 Erythema: intraepidermal peeling.

does not allow their normal function. All membrane proteins are therefore damaged, making the keratinocytes unable to survive. At the same time, intercellular proteins are also coagulated.

*Clinical Signs*

More clearly visible erythema can be seen, but no white pinpoints appear, yet (Fig. 54.2).

*Desquamation*

It can look like very thin dandruff.

*Risks and Problems*

Intraepidermic peels are usually not dangerous peels. Nevertheless, cases of PIH have been seen, making the prevention of this side effect necessary when the skin is known as sensitive. Neutralization of AHAs remain the main problem since it must be done following difficult rules (neutralization has to be done when an erythema appears—it is always irregular erythema—and in any case, before any sign of protein coagulation that would appear as skin frosting points). It is difficult to foresee the right moment for an ideal neutralization.

About TCA, no neutralization can reverse the proteinic coagulation; therefore the total amount of TCA that is applied on the skin has to be perfectly calculated, in relation with the skin permeability. The TCA application technique has to be perfect for an even penetration. Resorcine and salicylic acid are phenol derivatives, not widely used out of United States. Large surfaces treatments using phenol derivatives are suspected to potentially induce toxic reactions. TCA and AHAs, on the opposite, are not toxic products.

**Depth 3—Basal Layer Peel: High Security (HS)**

This is a very interesting peeling level, since it is easily reached and gives good results. Stratum corneum cells are completely removed; keratinocytes are largely damaged up to the level of basal layer keratinocytes (depth 3 in the graph) (Fig. 54.3).

Epidermis is nevertheless not completely destroyed, since many keratinocytes—less damaged by UVs—are living in deep epidermal papillae; skin regeneration is fast and easy.

Basal layer peels can be used, as serial peelings, for treating skin aging (Glogau 1-2), fine lines, epidermal melasma,



**Figure 54.3** Before and after four sessions of Easy TCA (Skin Tech), one peel every week, basal layer depths.

keratoses, and acne (from black dots up to papule-pustule acne). Together with a good control of melanin synthesis (blending bleaching cream—Skin Rebirth<sup>®</sup>), a TCA basal layer peel can treat many cases of melasma. If attention is paid to adequately clean the skin (remove black dots, open microcysts, etc.) and if the patient applies disinfecting creams and creams limiting the sebum production, then we can treat active acne, usually without antibiotics (see further Ref. 2 for peels and treatment tips).

#### *Main Types of Peels*

AHAs should not be used at this depth since this is the border after which AHAs side effects are prone to appear, are difficult to treat, and give inconveniences to the patient's social life. On the contrary, TCA represents the best choice for this depth, if the right concentration, formula, and postpeel care are selected.

#### *Action Mode*

We have seen (see depth 2) the TCA action mode: Keratinocytes destruction induces a basal layer strong reaction, dramatically stimulating the turnover of basal cells.

#### *Clinical Signs*

TCA coagulates proteins, and its entry through the domes of papillae induces a specific proteinic coagulation; dermal protein coagulation points occur, clinically appearing as little white marks (white pinpoint) called "frosting points" (Fig. 54.4).



**Figure 54.4** Basal layer peeling: frosting points.

#### *Desquamation*

It looks like a sunburning desquamation, allowing a social life in the majority of the cases.

#### *Risks and Problems*

Basal layer peels are usually not dangerous. The application technique is important since a perfect protocol is very secure. If the peeling application is a little bit too strong, basal layer peeling can nevertheless give the start to a vicious circle of inflammation based on free radicals liberation that induces cell damage, etc. If we allow such a self-stimulation of this inflammatory vicious circle, melanocytes could react and give PIH. Cases of PIH have been seen, making the control of this postpeel inflammatory vicious circle necessary. No herpes prevention is necessary. Mainly, problems are linked to too strong melanocytary stimulation, without adequate treatment, or to an irregular application, or to a too deep application, or to infectious rebounds in case of acne. Prepeel skin conditioning can be used from this point if the peeling used does not penetrate evenly or does not control the postpeel inflammatory reaction. If using Easy TCA peel, no prepeel conditioning is necessary. Except in case of deep scratching and/or strong local infection, no scar is to be waited for this peel depth.

#### **Depth 4—Grenz Zone Peel: HS**

This is a very interesting peel level, which is easy to perform, not very painful for the patient, has a low level of risk, and gives pretty good results. Stratum corneum and a large part of keratinocytes are destroyed. Acids penetrate slightly into the more superficial layers of papillary dermis, eliminating abnormal cells from epidermis (treatment of lentigines, keratoses) and eliminating many keratinocytes excessively charged in melanin and melanocytes producing the melanine (melasma). Grenz zone peel also directly stimulates the superficial coats of papillary dermis, allowing a strong collagen and elastin deposition into the grenz zone (German word, meaning border area). These grenz zone peels, together with basal layer peels, are depths of peel I use the most.



**Figure 54.5** Desquamation after Easy TCA up to Grenz zone.

#### *Main Types of Peels*

TCA is a must for these depths. AHAs are not used because of their irregular penetration, making risky their use for Grenz zone peels. Resorcine and salicylic acids are difficult to use for reaching exactly the Grenz zone. Phenol should be kept for other indications.

#### *Action Mode*

We have seen the TCA action mode. TCA coagulates keratinocytes proteins and also dermal proteins, inducing a wider skin “frosting.”

#### *Clinical Signs*

No more pinpoint of frosting, but “frosting clouds” are seen, together with a diffuse erythema.

#### *Desquamation*

Desquamation looks like a strong sunburning, easy to live with if the skin is fair. Nevertheless, dead skin becomes dark brown on darker phototypes (Fig. 54.5).

#### *Risks and Problems*

Patient’s social life, overall of dark phototype patients, can be difficult, during few days. At the same time, the risk of PIH becomes higher, making a “pigment synthesis sedation” quite interesting before and after this peel depth. PIH prevention is mandatory if the patient is phototype Fitzpatrick 4 or more or working outside, in a sunny country. Infections are uncommon at this depth, since immunitary system is still widely valid. Herpes prevention is not yet obligatory, except in special cases of frequent, recurrent herpes attacks. Other problems are the same as for basal layer peels.

### **Depth 5—Papillary Dermis Peeling: S**

Depth 5 peel is a border between secure and insecure depths. We reach some limits at this depth. Positive limits in the sense that a depth 5 peel is able to treat many skin defects such as lentiginos, solar keratoses, melasma, freckles, and fine lines. Negative limits,

since a papillary dermis peel is not able to treat real wrinkles or skin sagging, and a good point is that, when strictly respected, this depth is safe about scarring: scars never appear when a peeling is strictly limited at the level of papillary dermis.

#### *Main Types of Peels*

AHAs, salicylic acid peels,  $\alpha$ -keto acids, resorcine are not good choices. Phenol sometimes has been used to perform depth 5 peel, but the related (cardiac, renal, hepatic) toxicity makes me deny its use at this depth. TCA peel, if correctly applied, remains the master choice for a safe and efficient papillary dermis peel.

#### *Action Mode*

We saw already the TCA action mode.

#### *Clinical Signs*

After application, frosting clouds progressively or rapidly become pink-white uniform frosting that can progressively or rapidly turn into a pure white frosting (Fig. 54.6).

Why is it progressive or rapid? Passing from clouds to even frosting is progressive when we use relatively low concentrations, as Unideep (23% wt/wt—see Ref. 3) (Fig. 54.7). This concentration allows the MD to stop his/her—very safe—application as soon as he/she sees the desired frosting to appear. On the contrary, an even pure white frosting rapidly appears when using higher TCA concentrations, like 35% or 40% (wt/wt). In this case, it is not possible to stop the TCA action. It can be compared to initiating an artificial fire: we know how big the firecracker is, but we are not sure about the final result of the spectacle. Nevertheless, when the fuse is



**Figure 54.6** “Frosting clouds”: Easy TCA Grenz zone peel.



**Figure 54.7** Frosting of Unideep papillary dermis peel.



**Figure 54.8** Desquamation day 4 after Unideep papillary dermis.

inflamed, it becomes impossible to stop it or to modify the course of the future events. Identically, to believe that it is possible to undo (by neutralization) what TCA did is a deep misunderstanding. Frosting appears as pink-white, as long as the acids do not coagulate the proteins in blood vessels. When acids are strong enough for coagulating the well-defended perivascular area, blood cannot pass until the top of dermal papillae, close to epidermis basal layer, and frosting tonality passes from pink-white to pure white.

At the same time, as the acids penetrate dermis, they coagulate proteins sticking epidermis to dermis, and the sign of “epidermal sliding” appears. This sign will last for a while and disappear when dermal edema is strong enough for tensing epidermis over it.

#### *Desquamation*

It is quite important, looks like a snake changing its skin; it lasts from 6 days (Unideep peel, Skin Tech) to 8 to 12 days (usual TCA in water solution, pharmacy made) (Fig. 54.8). Social life is usually possible during the first evening, but not from the next morning. Days 2 to 6 are days of reclusion, during which skin will largely peel in more or less dark plaques, in relation with the phototype.

#### *Risks and Problems*

The most immediate risk consists in infections: viruses, bacteria, mycoses find the skin totally open and without defenses. It is easy for them to penetrate and locally proliferate. It is therefore mandatory to prevent viral infections using herpes prevention (valacyclovir, i.e., 3–4 days before and 4–5 days after peel). Bacterial and mycotic infections can be avoided by a strict control of medical hands and material cleanness as well as by avoiding any other source of iatrogenic infections. The patient has to be aware to wash his/her hands before any contact with his/her skin (like scratching), to avoid direct contact with mammal or nonmammal pets, and to call the doctor for any question or inconvenience that could occur to him/her. Scratching the skin after papillary dermis peel usually induces infection. Nontreated or badly treated infections could induce PIH, depigmentations, or scarring.

Another risk comes from the fact that not every peeling solution is able to evenly penetrate the skin. Simple TCA in water solutions irregularly penetrate the tissues and can give

uneven results: some areas are too deeply treated (giving local erythema, pigmentations, depigmentations, infections, scarring, etc.).

The real action of TCA is largely hidden during the application itself; damages can occur that the practitioner cannot see immediately and, hence, cannot correct. Therefore, the concentration of the peeling solution and, still more important, the total amount of TCA applied on the skin during a period of time has to be strictly calculated before application. No neutralization of TCA is possible, which is explained later in the text.

When using a simple TCA in water solution, skin conditioning is mandatory for four main reasons: to allow a more even penetration, to allow a deeper penetration and hence a better result, to keep melanocytes in rest and limit the occurrence of PIH, and to stimulate the basal layer turnover and facilitate postpeel skin regeneration. Mixtures of AHAs, tretinoin, hydroquinone are often used for this purpose.

### **Depths 6 and 7—Reticular Dermis Peeling**

From “QS” to “DD,” meaning that it is always dangerous to perform such a deep peeling, but it can be done in some cases.

Reticular dermis peel is a kind of Holy Grail of peeling; this depth of peel allows treating nearly every pigment problems, it tenses the skin and removes wrinkles. Nevertheless, thick and oily skins are not the best candidates for a reticular dermis peel since these skins resist very well to the action of acids. Unfortunately, folds usually resist to the action of deep peelings. Very often, we have to discuss, with the patient, the choice between two therapeutic options: surgical lifting or deep peeling. At Hera Clinic (Empuriabrava, Spain), our first guide is the following simple decision table (Table 54.1). Naturally, this table has to be adapted to every specific skin and situation. The global meaning is that we will not recommend a phenol peel to a patient with thick sagging skin and no sun aging problem. On the contrary, we will not recommend surgery to a patient with thin skin, without sagging but with important pigment or sun aging problems.

The quest for Holy Grail is a risky trip, so also is deep reticular peeling. Not only the selected peeling solution has to be perfectly adapted to the doctor’s and the patient’s aims, but also the application technique and postpeel care have to be totally professionally done. Full-face reticular peeling is a very aggressive treatment that lets no place for rough improvisation. Any mistake leads to scarring process, and pigmentary problems are frequent.

Nevertheless, reticular peels are pearls in good hands and mind.

#### *Main Types of Peels*

Two main molecules are used for reaching this depth: TCA is one of them and phenol the second one. I really appreciate

**Table 54.1** Problems and Preferred Treatments

Problem	Preferred treatment
Pigmentary problems	Peelings
Sagging skin	Surgery
Pigmentary and sagging	(1) Surgery, wait for 6 months, (2) phenol peel
Thick skin	Surgery
Thin skin	Peeling



**Figure 54.9** Frosting of OTP + desquamation secondary to intra-epidermic peel. *Abbreviation:* OTP, Only Touch Peel.

concentrated TCA for performing focal deep peels, for deeply treating lentigine and keratoses of diameter less than 1 cm (Only Touch, e.g., is a 45% wt/wt TCA), but I would not be keen to use it for large areas, as a full-face peeling. In this case, phenol seems to me to be better, its activity depth can be better kept under control and the results of phenol are definitely better than TCA, even at similar depth. It seems that phenol has a better “rebuilding effect” on the skin than that by TCA. My best phenol peel is actually “Lip and Eyelid Formula,” Skin Tech, which is an oil of phenol, penetrating slowly into the skin, what limits its general toxicity (giving to the liver, the lungs, and the kidneys more time for detoxifying it), and what allows a longer contact time between phenol and the skin proteins, inducing a potential larger proteins coagulation and hence a better result (Fig. 54.9).

#### *Action Mode*

Phenol is proteolytic or proteocoagulant, depending on the concentration. Higher concentrations are proteocoagulant and lower concentrations are proteolytic. For peeling purposes, the best concentration range is between 40% and 60% (wt/wt). Nevertheless, many substances can interfere with its action and speed up or slow down its penetration. These substances are largely described in my book (2), in which close to 200 pages are specifically available about phenol peels.

#### *Clinical Signs*

Acids reach reticular dermis after having largely coagulated papillary dermis, showing a pink- or pure white frosting (depending on the concentration, an aggressive peel will

develop an immediate pure white frosting, without passing by a pink-white one). Quite fast after the typical papillary dermis frosting, the tonality will shift to a grey-white or to a grey frosting.

It is possible to reach this depth by applying various acids concentrations, nevertheless, I always felt more secure by using less concentrated products, but applying more coats. Indeed, when we are using proteocoagulant products, the final result depends on the total amount of active acid molecules that have been able to interact with skin proteins. A very strong and aggressive peeling solution could induce a superficial thick coagulation, only letting pass the acids at the level of higher skin permeability, what could induce irregular results and local overpeelings. When using a progressive application technique, we can always decide to apply no more acid on the higher permeability areas, and keep applying on the areas where we did not see the desired frosting to appear. Doing this allowed me to have ZERO overpeels during the last 20 years.

#### *Desquamation*

Desquamation is huge, always forcing to a social retirement of seven to eight days. Dead skin layers should be kept as a natural protection and only extracted at around day 6 or 7, if this extraction is easy, atraumatic. Phenol peel can be used under a complete 24 hours occlusion, inducing a maceration of the upper coats of the skin. During occlusion, skin melts (in open techniques, skin usually dries) and has to be protected by using Bismuth subgallate powder. From day 5 or 6, sterile petrolatum jelly can be applied on the dead skins, it will help in desquamation. Occlusion makes the phenol peel to be deeper, more efficient. TCA occlusion does not have the same result.

#### *Risks and Problems*

Histologically, there is only one reticular dermis, situated between papillary dermis and subcutaneous tissues. However, speaking about peelings, we have to consider that we face two different depths.

Into the more superficial reticular dermis, overall at the face level, we still can find keratinocytes (mainly at the level of hair roots and sebaceous glands: sebocytes are phenotypically differentiated keratinocytes, able to undifferentiate into normal keratinocytes when necessary to repair the skin). Superficial reticular dermis still has material to rebuild the skin. Deep reticular dermis is empty of this reservoir but contains big fibroblasts, also differentiated to be able to synthesize a thick bundle of collagen that will stick to the neighboring fibroblast. Moreover, they are considered as contractile nonmuscular cells, able to contract when necessary. They are mainly responsible for the scarring process: when these cells are strongly stimulated during a self-maintained inflammatory vicious circle, scarring can appear.

#### *Problems*

All possible side effects can appear when using deep peelings. Pigment problems are frequent, since deep TCA kills melanocytes and phenol can make them impotents, unable to synthesize melanin. As a result, many cases of unaesthetic depigmentations have been seen in the past. A new formulation (Lip and Eyelid Formula, Skin Tech) seems to be much safer on this point of view, since it induces mainly PIH, which are easy to treat, whereas “porcelain skins” cannot be treated. The following table gives a relation of many of the possible side effects.

Locoregional side effects	Regional side effects
Insufficient results	Larynx edema
Postinflammatory hyperpigmentations	Long-lasting face edema
Melanotoxicity (up to porcelain skin)	Dynamic wrinkles resurgence
Demarcation line	<b>General side effects (phenol)</b>
Erythema	Symptoms occurring rapidly
Telangiectasias	<i>Neurological problems:</i>
Not even complexion	headaches, acouphens,
Scars (+ ectropion or entropion)	hypoacousy, paresthasias,
Prurit	muscle hypotony, stupor
Scratching lesions	<i>Digestive problems:</i> nauseas,
Bacterial, viral, mycotic surinfections	vomit, Pain in belly, diarrrhea
Acne, milium grains	<i>Cardio vascular problems:</i>
Conjunctivitis	arrhythmias, asystole
Iritis, opacification of cornea	Symptoms occurring later
Postpeel pain	<i>Nephropathy</i>
Sun sensibility	<i>Hepatopathy</i>
Dilation of pores	<i>hemoglobinury,</i>
Petechiae, purpura	<i>methemoglobinury</i>

## ABOUT ACIDS NEUTRALIZATION

Acids neutralization is a recurrent problem. Why to neutralize? What to neutralize? How to do it? When to do it?

Together with the dermatological use of AHAs appeared the notion of neutralization. Indeed, preexisting peelings (phenol derivatives and TCA) had not and could not be neutralized, since proteocoagulant molecules definitively interact with skin's proteins, combine with them, forming a kind of conglomerate that cannot be separated. As a result of this interaction, non-AHAs are largely and automatically neutralized and trapped into destroyed proteins whose tridimensional structure have changed, inducing the well-known sign of frosting. Neutralization of proteocoagulant acids is therefore impossible after their action began. As a maximum, we could neutralize an eventual floating excess over the skin, before this excess could penetrate the skin.

Is this even really possible? This idea of neutralizing proteocoagulant acids (as is TCA) is in reality totally tricky since we have to introduce a time scale in our discussion: the appearance of a frosting is a signature of past events. The frosting that we see right now does not represent what is actually happening, but what happened to the skin some time ago. [The frosting we see in T(0) results from a past action of the acids into the skin. It can be compared to the fact that the star light that we see has been emitted millions of years ago (the age of universe being supposed to be at least 17,300,000,000 years). What we see in the night sky can have been emitted in the past by a star that is now dead and maybe now transformed into black hole after a last fantastic explosion followed by a contraction to infinite levels of energy.] Frosting events have some kind of invisible inertia; these are not immediately appearing phenomenons. Proteocoagulation will continue going on during the neutralization process. It is therefore very risky to apply too much of the (phenol derivative or TCA) acid on the skin, thinking that it will be possible to neutralize it after seeing a frosting to appear. That's the best way for going to the overpeeling. To try to neutralize TCA after seeing a frosting could be compared to trying to stop an arrow just before it touches the target. Moreover, neutralizing a proteocoagulant acid never means to reverse the potential

damages caused to cellular proteins or matrix proteins. When an acid combines with amino acids into a protein, it is transformed into a salt that sticks to this amino acid and modifies the volumetric, tridimensional, proteinic appearance.

This is why a safe behavior is to rub on the skin the right amount of acids to get the desired frosting, without any neutralization. Remember that few seconds only are necessary for proteocoagulant acids to pass through epidermis: that is why phenol induces skin anesthesia 12 seconds only after its application. (At such speed phenol coagulates sensitive nerve sensors, inducing local anesthesia.)

On the contrary to proteocoagulating acids, we have seen that AHAs have a very low proteocoagulant power, they do not easily combine with proteins. Their natural neutralization by the skin only could be done by using the skin buffer potential, which acts too slowly. Without neutralization, pure, nonpartially neutralized AHAs would finally burn the skin.

We cannot neutralize an acid by adding water to it: When we pour water in a recipient containing an acid solution, we only just dilute this acid; a huge dilution is necessary to lower the resulting pH. Pouring water on the face, after peeling, cannot therefore be considered as neutralization. Pouring a basic solution in a recipient containing acid will induce chemical acid-base reactions; the acid will become a salt that has no more protons to liberate in solution and therefore is no more an acid. Neutralization changes the chemical structure of acids. Simple sodium bicarbonate in a saturated solution can be used to neutralize AHAs.

Finally, the answers to the questions in top of this paragraph are simple: we neutralize AHAs, we cannot neutralize proteocoagulant molecules. A slightly basic solution, in good volume, will be poured on the skin until the end of chemical reactions (usually seen as little bubbles). Neutralization of AHAs should begin as soon as an erythema can be seen and before any frosting appears.

We touch here the big question: when to neutralize AHAs? A too early neutralization lets not enough time to acids for interacting with skin, and the result will be very poor. A too late neutralization allows acids to burn the skin, and induces many side effects. That is why industry proposes partially neutralized AHAs (pH 2.5, 3, 3.5) that are less dangerous and that can be washed with simple water, since they are between 10 and 1000 times less aggressive (efficient) than pure AHA solution, without partial preneutralization. (There is a logarithmic relation between pH and aggressivity: pH 3 is 10 times less aggressive than pH 2, and 100 times less than pH 1.)

There is one exception, called "Easy Phytic Solution" (EPS): in spite of the solution's very acidic pH (0.5–1) and a total concentration of acids of average 60%, this AHA solution does not need to be neutralized. The time controlled technology permits a slow release, a complete progressive penetration, and a full action of all acids. Absence of neutralization is equal to absence of problems and greater efficacy. Best indications are acne, photoaging prevention, and treatment. Easy Phytic is made of three AHAs: glycolic acid, lactic acid, and mandelic acid. AHA is adsorbed on the polar groups of keratin chains and inhibits the reactions between these groups. This improves elasticity of the skin and  $\alpha$ -hydroxy acids are better than  $\beta$ -hydroxy acids for this because the  $\alpha$  position of the hydroxyl group allows a better penetration between keratin chains than the  $\beta$  position. The three AHAs show different velocities of penetration through the skin. The smallest—glycolic acid—penetrates first, followed by the lactic and then the mandelic.

These acids begin their action at the level of the upper layers of the epidermis. Because there is no neutralization, they continue their action, going down inside the epidermis and reaching the dermis, slowly and without ever overpassing the capacity of natural neutralization by the skin itself. So the acids of EPS lose progressively their aggressiveness into the skin, producing their full activity. Phytic acid, is not an AHA, this is a big molecule of inositol hexaphosphoric acid considered as an excellent antioxidant and an antityrosinase. It binds iron. In our point of view, phytic acid is unable to produce any peeling effect, so why can we find phytic acid in this solution? Actually, every peeling produces an inflammation; this inflammation produces free radicals (FR) and vasodilatation. Vasodilatation brings more oxygen in situ allowing the formation of more FR. FR binds immediately with the closest structure, damaging it. So a peeling always promotes the skin regeneration but induces a lot of FR that can damage the structures that are supposed to regenerate the skin during the postpeel period. The actual scientific understanding of aging processes generally blame FR as one of the major factors responsible for cells degeneration. It is important to fight these FR during the postpeel period. Phytic acid slowly penetrates the skin, after the three AHAs of the EPS solution have opened it, and can be present in the skin when FR are produced in parallel to the inflammation. Scavenging FR cuts the vicious circle of inflammation-vasodilatation-FR and scavenges the FR-produced postpeel.

It is known that AHAs make a thicker epidermis, produce more mucopolysaccharides in the dermis and a better quality elastin. The density of papillary dermis collagen is better and patients under EPS describe a tightening sensation after peeling and a visible difference of the aspect of the skin.

How to use it? Cleanse the skin twice with the Skin Tech's cleanser foam, rinse, and dry. Apply a maximum total volume of 2.5 cc of EPS on the face, using a little cotton ball, poured only once into the peeling solution. Apply it in successive coats, massaging the face between every coat for uniformization.

When the patient declares that he/she feels a tingling sensation, apply the last coat, using the same cotton ball. No frosting at all should occur. Two or three coats are usually sufficient. In the event of accidental frosting, neutralize immediately (sodium bicarbonate solution). Do not neutralize. For more information about details of the application technique, please refer to the product information sheet or Ref. 4.

## ABOUT TCA

Many books have been written about TCA in water application techniques and I will not rewrite it. Nevertheless, I would like to point out few important details.

The main questions, the more troubling doubts of beginners are the following: What is the best TCA concentration? How many coats? How often? How and when to neutralize? These are not the good questions since the answers would give an appearance of an easy cooking recipe to be inflexibly respected.

The easiest of these questions to be answered is about when to neutralize. TCA action cannot really be neutralized (see earlier text).

The best TCA concentration is the one we selected. The point is to know how to select a TCA concentration and how to calculate it. I have explained at length (2) why I prefer to use a weight by weight (wt/wt) calculation and not a weight by volume (wt/vol) or a volume by volume (vol/vol) one. (A 40%

TCA solution could be calculated in many ways: 40 g TCA + 60 g water or 40 g TCA + 100 mL water or 40 g TCA + the necessary quantity of water for obtaining a final 100 mL solution or even, 100 g—or 100 mL—of any of the above described solutions, diluted with water in wt/wt, wt/vol, or wt + vol. This makes too many possibilities and too many reasons for making a mistake. For more reproducible peelings, I definitively selected the wt/wt concentration. For me, 40% TCA is always 40 g of fresh TCA crystals mixed with 60 g of water to do a final weight of 100 g. It is a real 40%.)

In short, we are using chemical products and we should keep our calculations scientifically reproducible and totally correct. Only the wt/wt calculation has a sense in this point of view, even if the wt/vol or the vol/vol is more common in United States.

The second point is to select the right concentration for one patient. Remember two points: first, a thick skin patient will need more acid than a thin skin patient; second, the most important is the total quantity of acid that is able to interact with proteins. Too concentrated acid applied on a thin skin will burn it immediately but will do a great job on a thick oily skin. Looking at the thickness of the skin fold on the area of malar bone gives us a simple clinical appreciation of skin thickness: if the fold is 1-cm thick, the skin should be "normal"; less than 1 cm, the skin is thin; and more than 1 cm, the skin is thick. Thin skin being more sensitive to acids than thick skin, this can help us to select the concentration.

Nevertheless, transepidermal acid penetration does not only depend on the skin thickness but also on the type of acid (a little acid will penetrate faster than a big one—long fatty acids, e.g., penetrate more slowly through the skin than the little lactic acid). Transepidermal penetration also depends on the skin permeability and the prepeel skin conditioning. A thick oily skin (one with a fold of more than 1 cm) after skin conditioning and acetone degreasing can become as permeable as a thin skin. Glycolic acid reduces stratum corneum thickness, with tretinoin for stimulating basal layer turnover and regeneration and for reducing the stratum corneum permeability: this kind of prepeel conditioning makes the skin much more permeable. Acetone not only degreases skin but also begins a protein denaturation that makes the skin more permeable. A skin dermabrasion (preferentially using 3M wet or dry sandpaper 200) easily removes the stratum corneum and largely deepens the action of the acids. I use this quite difficult technique that I called "anterior chemabrasion," together with Easy TCA peeling in the treatment of acne scars and old atrophic and deep stretch marks, with splendid results.

We can see that many events are able to modify the skin permeability: did the patient do a scrubbing for having a clean skin before seeing you? The skin will be more permeable. Did the patient wax the face before peeling for depilation? More permeability! Did the patient apply an oily moisturizing, a sun screen, a gel containing hyaluronic acid before coming? It will reduce skin permeability.

How many coats to apply? Every peeler would like to have a clear and simple answer to this question. Unfortunately, the number of coats depends on what is described above about skin permeability. It also depends on the TCA concentration of the solution. Note also that thinking about concentration only is tricky because there are so many variants that the problem of concentration is only a little part of the global decision.

Globally, we can take two different ways. The first one consists in guessing what will be the right concentration for a



single patient's skin, and praying during some days, hoping that there was no mistake and that the acid will stop its action at the right depth. The second one, that I naturally prefer, is to use very few different concentrations (3 different concentrations) but to apply progressively several coats until I see the desired kind of frosting to appear. This way always brings my peel exactly to the desired level, without possibility of mistake.

### Let's Take an Example

Patient with a normal thickness and permeability skin, phototype 2, prepeel classical conditioning, and we would like to reach the grenz zone: the very good and easy case!

I can decide to apply a 30% TCA (yes, but wt/wt? wt/vol? etc.). What I cannot decide is about how deep this acid will penetrate by itself: I just can rub the product on the skin and see the result at the end, knowing that more than one coat of a 30% wt/wt TCA solution on such a skin can be dangerous, or on the contrary can be insufficient. We will see the action of the acid solution, but only when the eventual damage is done and is irreversible. This is why there are so many reports of skin damages after TCA peel; this is why some authors erroneously claim that TCA is not adapted to melasma treatment. It is nevertheless only a question of application technique and prepeel decisions. A 30% wt/wt TCA solution rubbed once on a normal thickness skin after prepeel conditioning usually gives a pink-white uniform frosting, showing a papillary dermis penetration. We overpassed our target that was grenz zone.

Another possibility for the same patient is to use a lower concentration TCA solution, let's say a 15% wt/wt solution. A first coat induced only erythema: we understand from it that the skin was less permeable than guessed and that we reached the epidermal level only. When the skin will be dried by evaporation, we will apply another coat of the same acid solution: the skin will show little frosting points and we will deduce that it reached the basal layer depth. A next coat would induce a cloudy frosting, sign of the penetration of the acids into the grenz zone. When we see these frosting clouds, we stop the TCA solution application and we know that the peel reached exactly the desired depth.

Usually, peelers focus their attention on a good prepeel conditioning for a better and more even penetration and a faster regeneration. Nevertheless, a better attention should be paid to the immediate postpeel events, to the inflammatory reaction that began immediately after the first contact with the first drop of acid applied on the skin.

This inflammatory reaction is necessary but dangerous in the same time. A peel that would induce no inflammatory reaction would also not be efficient at all, since inflammation is the real skin rebuilding source. At the same time, if this inflammation is uncontrolled, if it is self-maintained, it enters into a vicious circle in which the free radicals and the proinflammatory components liberated from cell destruction induce more cell damage and more inflammation. This inflammatory vicious circle is responsible for a long stimulation of melanocytes that will respond by synthesizing more melanin and inducing PIH.

It is easily understandable that a peel can be a booby trap: you think that your chemist prepared a 30% mass by volume but he did it wt/wt (what is stronger), your patient made a virtual mesotherapy (a slight abrasion using sandpaper, application of specific vitamins, and other elements on the skin, or use of nonthermogenic radiofrequencies for inducing an intra-

cellular penetration) or a depilation face wax the day before peel: the patient's skin will be permeabilized, acids will penetrate faster and deeper and you will get (surprisingly?) an overpeel and side effects. I progressively solved this problem by using a safer and easier formula: Easy TCA peel (1,3).

This formula allows us to avoid the long and uncomfortable prepeel conditioning phase in the huge majority of the cases as it can be applied using the progressive technique explained above, as it uses a specific postpeel mask, able to control the postpeel inflammatory reaction, and as it will be repeated once a week during four weeks. Every peel, done up to frosting points or maximum local frosting clouds, treating an eventual pigment rebound induced by the preceding peel. I would use a prepeel conditioning only in specific cases, such as in a phototype 4 or 5 patient with a long history of familial melasma.

The Easy TCA postpeel mask is a quite complex formula, containing vitamins, trace elements, a lot of strong antioxidants, tretinoine precursors, selenio-methionine, anti-tyrosinases, etc. This cream is applied once by the practitioner, immediately after the desired frosting has been seen. It immediately scavenges free radicals, stopping the excess of immediate inflammatory reaction in the same time as the burning sensation induced by the easy TCA peel solution. It brings into the skin elements that can help the skin to regenerate faster and lowers the tyrosinase activity. Postpeel penetration of ingredients is dramatically modified by the previous application of the peeling solution. The postpeel rate of penetration is much higher than the normal skin rate. The skin is much more permeable during the close postpeel period: sebum and corneocytes do not act any more as a barrier and purely water soluble ingredients can rapidly pass through this modified epidermis.

So, high quantities of stimulating factors and antioxidants can reach the dermis. It is clinically evident that the residual inflammatory reaction is strong enough for stimulating the skin architectural rebuilding, but not strong and long enough for stimulating melanocytes or for slowing down the basal layer sequences of regenerative events. Colleagues often asked me how and why this cream can immediately stop the burning sensation, even if it is not a neutralizer (this cream is not a basic one), and if the frosting signs continue to appear normal, even after having applied the postpeel mask. I unfortunately cannot scientifically answer to this question but have a theory: my understanding is that the postpeel mask antioxidant properties are such that they break the proinflammatory immediate postpeel reaction. It is well known that inflammatory reaction represents a big part of pain, usually.

To summarize: After having used many different peeling formulas and spent postpeel nights of insomnia, I decided that it should be possible to use TCA without posttherapeutic nightmare. This is what brought me this Easy TCA formula: Easy to do (10 minutes as a maximum for face and neck), not expensive, not painful (never needs any kind of anesthesia or painkiller), no skin conditioning (peeling solution and postpeel mask have this role), patient's social life is possible (desquamation looking like a sunburn), no phototype limitation (phototype allowed: from 1-6), very little percentage of side effect (average 1.7% of transitory side effects, duration less than 8 days—unpublished statistic established on a total amount of 5000 peeling sessions in Clinica Hera, Empuriabrava, Spain: 28 transitory easy to treat side effects; no definitive side effect). This peeling, applied according to different protocols, allows for a wide spectrum of depths of action and therapeutic

indications from active acne to pigmentations and acne scars, photoaging, and deep old stretch marks. See further Ref. 3, left column, treatment tips, peelings for a complete description of active acne, stretch marks, melasma treatments, together with the protocol for local phenol peel around eyes and lips. It can be applied to both face and body. Moreover, it can be associated, during the same session, to laser, Intense Pulsed Light (IPL), mesotherapy, radiofrequencies, depilation, botulinum toxin, surgery, telangiectasias treatment. Easy TCA (as a basal layer peel) can be performed 10 minutes after botulinum toxin injection; we have not seen migration or shorter results after this combination treatment.

Even hyaluronic acid injections for wrinkle treatment are allowed, immediately before Easy TCA peel.

The hyaluronic acid notice for injection instructs not to perform peelings after hyaluronic acid injections. Nevertheless, this recommendation is valid only because of the huge release of free radicals after usual peelings. Free radicals rapidly damage the hyaluronic acid polymer, breaking it and making its life shorter. Easy TCA postpeel mask scavenges free radicals at the same time they are produced, which can stop self-maintained free radical reactions able to damage hyaluronic acid polymer.

At the same time, I decided to stop trying to guess what would be the best concentration of TCA for a patient, but only use the Easy TCA solution of which I progressively apply the necessary number of coats to get the desired frosting.

In the preceding paragraphs, I told that I was only using three different concentrations and want now to bring light on this.

The main peeling I use, on maybe 80% to 85% of my patients is Easy TCA: solution containing vitamins, antioxidants, AHAs, and saponins, together with 15% wt/wt TCA. This peel benefits from the important postpeel mask protection against postpeel inflammatory reactions, immediately stopping the postpeel burning. Depending on the number of coats I pass on the skin, I drive my peel into epidermis, basal layer, grenz zone, or even papillary dermis. Nevertheless, papillary dermis peel needs many coats of Easy TCA, and this is uncomfortable for the patient. This is why I use a derivative of Easy TCA when I want to reach papillary dermis: Unideep (a formulation developed by Skin Tech) has the same structure as Easy TCA—it is a peeling solution containing 23% wt/wt TCA and an adapted postpeel mask with the same aim as Easy TCA. Sometimes, I even need to go very deep into the skin for treating focal old lentigine or solar keratoses: naturally, we often can do it using successive focal coats of Easy TCA or Unideep, but the work is easier when using Only Touch Peel (OTP)—same qualitative base solution than Unideep, but containing 45% wt/wt TCA. OTP (a formulation developed by Skin Tech) has no postpeel mask and has to be used in combination with Easy TCA for avoiding the postpeel inflammation. Indeed, OTP without Easy TCA induces PIH in more than 60% of the cases. When done immediately before Easy TCA, the percentage of PIH is much less important: a maximum of 10%, if the protocol is respected, even less if the patient does not scratch the scabs. OTP can be used on little surfaces only: it is always a focal peeling for treating lesions of diameter 1 cm. OTP is applied, avoiding excess product, with a fine cotton bud or a wooden toothpick or skewer. Touch the lesion to be treated quickly, precisely, and once only with the chosen applicator and wait until the acid solution has dried completely. A significant frosting will be seen to appear quickly on the face, slowly on the body. If no such frosting

occurs, however, repeat the application cautiously a few minutes after the solution has dried. Immediately after the frosting occurs, apply the first of the four basic protocols of Easy TCA on the entire treated area, including the one where OTP has just been applied, to obtain an even result and limit the risk of side effects.

## PEELINGS AND FIBROBLASTS

Dermal fibroblasts represent a major cell, not only in the understanding of peelings: their correct stimulation by any mean would be able to lead to a good skin rejuvenation. Fibroblasts have a dendritic appearance, like Langerhans cells, but have no immunitary known function. Fibroblasts synthesize all the intercellular matrix components and play a vital role during the formation and the contraction of the granulation tissues that appear during the wound healing processes and postpeel regeneration events. Huge morphological variations exist within this cellular population: papillary dermis shows little horizontal fibroblasts (4–7  $\mu\text{m}$ ), their dendrites have contact with several collagen fibers. Stimulation of these fibroblasts is responsible for a dense deposit of horizontal neo-collagen, in the top of papillary dermis.

Medium depth dermis and deep dermis show bigger fibroblasts, with a variable orientation. Dendrites have contact with one big bundle of collagen only. The very deep dermis, at the limit of hypodermis, contains very big fibroblasts (16  $\mu\text{m}$ ) with long dendrites (up to 180  $\mu\text{m}$ ), forming a continuous net.

Inflammatory reactions and healing processes induce the appearance of many hybrid cells, called myofibroblasts. These are phenotypically modified fibroblasts having some characteristics of muscle cells and are responsible for the retraction processes during skin healing. Cytoplasm of myofibroblasts contain myofilaments connected with cell membranes, responsible for cell contraction and eventual scarring processes.

“Normal depth” peelings will stimulate the full population of fibroblasts, without overstimulating myofibroblasts: they give a better skin tension, without scarring (up to papillary dermis peels). Too superficial peels only are able to slightly stimulate fibroblasts synthesis: the result on skin tension is weak (intraepidermal peels). Deep peelings will strongly stimulate fibroblasts and myofibroblasts, inducing a tridimensional tensing effect on facial tissues; that is what gives a well-done phenol peeling. Too deep peeling, locally hypodermal peelings, focal overpeelings let the skin without any other regeneration possibility than the strong myofibroblastic contraction, bringing about unaesthetic scarring processes. We can therefore easily understand that scars only happen when something wrong happened to the skin: it can be a problem induced by the physician having applied a too concentrated solution or a too strong prepeel conditioning or by a patient having scratched and infected a newly peeled skin.

Some genetic disorders make the skin prone for postpeel scarring, like Ehler–Danlos syndromes. Insulin-dependent diabetes is also a risk factor for deep peels, and there are other side effects (2).

Nevertheless, it is largely admitted that papillary dermis is the limit from which scarring process can be switched on. It means that as long as a peeling does not enter into reticular dermis, there is no danger of scarring. The problem here is how to strictly limit the penetration of acids until the desired depth? One of the possible answers has been described in the TCA paragraph.

## ABOUT PHENOL

Many things have been said about this molecule, some represent the truth, others are only urban legends. One example of truth: it is possible to remove completely the wrinkles on the upper lip, using phenol peel. One example of legend: the patient can die just after the very first contact with the first drop of phenol. I will not say much about phenol peels, since a little part of a short chapter is not the right place for learning about it. Phenol peel has to be learned hands on, following the patient day after day during at least eight days. Nevertheless, let's divide our phenol paragraph in two parts: the local phenol and the full-face phenol.

Local phenol is a very simple procedure, the fastest of all peelings, and gives amazing results. Chemical blepharoplasty and/or cheiloplasty are easy to perform with phenol. The needed quantities are largely under the threshold of toxicity and new formulas (see in the beginning of this chapter) are considered as self-blocking at the level of the upper part of reticular dermis (2). Moreover, new formulas no more induce "porcelaine skins," and skin tanning can be possible in the future. Local phenol peelings are therefore one of our frequent treatments for deep wrinkles of the upper lip, for the eyelid area, and in some cases for wrinkles between eyebrows, on the top of the nose pyramid. Lower lip and mental area are much more difficult to treat with local phenol. Often, at this level, a deep mechanical abrasion has to be used after phenol peel to achieve good results.

Special attention has to be paid to the patient selection: phototypes 2 and 3 are the best patients, but patients showing yellowish sun-damaged skin should be avoided since postphenol skin regeneration will completely renew the treated skin that will appear like a baby skin surrounded by irregular color skin (Figs. 54.10–54.12). The case of freckles is also a trap. These clear phototypes are good indications, but freckles will com-



**Figure 54.10** Before local phenol (Lip and Eyelid Formula—Skin Tech).



**Figure 54.11** Eight days after local phenol lower eyelid—Unideep on the rest of the face for uniformization.



**Figure 54.12** Eight months after local phenol lower eyelid and Unideep.

pletely disappear at the level of phenol peel and not on the rest of the skin. In these cases, a local phenol peel can be tried, together with a papillary dermis peeling on the rest of the face, calling attention of the patient that, even in this case, a demarcation line could be seen between the area treated by phenol and the one treated by TCA.

Postpeel period is dramatically important: see your patient nearly everyday during the first week; this will allow you to detect infections, abnormal reactions, etc. For more practical information, please refer to the website in Ref. 2, left

column: "peelings" and "treatment tips"; there are clear tables about how to do the phenol peel and the postpeel.

Full-face peeling is another story, since the phenol toxicity has to be avoided or even treated in exceptional cases. Even if some physicians still feel comfortable in doing it as an office procedure, as in the past, I would strongly recommend to perform this kind of peel in a secure surgical environment, with the help of a trained anesthetist (nerve blocks associated to a deep sedation or neuroleptanalgesia). Nothing, usually, happens but all the lights are red and we have to be very careful, since an accident would never be forgiven. Strict application rules have to be followed. The postpeel period after phenol peel is quite uncomfortable for the patient, it looks like after a deep ablative CO<sub>2</sub> laser procedure. Procedure is specific, many details have to be respected if we want to do it very safely, postpeel is difficult. I cannot describe here the full process of a full-face phenol peel and how to avoid all the traps. Nevertheless, my *"Textbook of Chemical Peelings"* contains average 200 pages dedicated to all aspects of phenol—and phenol derivatives—peelings procedures.

Apart from that, full-face phenol peeling is one of the most satisfying treatments I ever performed: many patients look 15 to 20 years younger after phenol peel. Skin aging goes many years back and goes on from there: usually, patient never gets again such an old skin as they had before peel. Full-face phenol peel can be combined with surgery, but not at the same time. When necessary, we are used to perform a face lifting as first procedure and a phenol peeling as second treatment, six months after in order to achieve complete face rejuvenation. In the same time, we treat neck, décolleté and hands by other procedures. New light phenol peels appear on the market, some of them being efficient, others having the efficacy of a medium depth TCA (papillary dermis) peel, Unideep type. Future will tell us more about the exact efficiency and toxicity of these low phenol concentrations.

## CONCLUSIONS

The world of peeling continues to be discovered, its treasures are able to make happy a big majority of our patients. Nevertheless, we cannot begin our exploration of these treatments, groping our way along, following any light that can appear in the sky as a shooting star: while we would look in this direction, we are at risk to fall in deep dangerous traps. Exploration of the world of peeling has to be done carefully, progressively, using good material, having at our disposal the necessary experience for passing from one step to the other. For example: deep full-face phenol or chemoabrasive techniques for stretch marks or acne scars should not be the first peeling of our life. The problem will not be the realization of the procedure itself but rather what we will have to face during the postpeel period, the problems that we will have to solve. The door of peeling world should open on VHS or HS peelings only. Beginners should use depths 1 to 3 peels first, before trying deeper treatments. Deep procedures have to be reserved for experienced doctors only.

## REFERENCES

1. Deprez P. Textbook of chemical peelings, series in cosmetic and laser therapy, Informa Healthcare, 2007:5–12.
2. Deprez P. Textbook of Chemical Peels. London: Informa Healthcare, 2007.
3. Peelings and Treatment Tips. Available at: <http://www.estetik.com>.
4. Skin Tech. Product information. Available at: <http://www.skintech.info>.

## BIBLIOGRAPHY

- Alberts B, Bray D, Lewis J, et al. *Biologie Moléculaire De La Cellule*. 2nd ed. Médecine-sciences, Flammarion.
- Berne MB, Levy NL. *Physiology*. 3rd ed. 1993.
- Briden ME. Alpha-hydroxyacid chemical peeling agents: case studies and rationale for safe and effective use. *Cutis* 2004; 73(2 suppl): 18–24.
- Brody H-J. Peeling Chimique de moyenne profondeur. *J Med Esth et Chir Derm* 1987; 14(56):313–318.
- Bulengo-Ransby SM, Griffiths CE, Kimbrough-Green CK, et al. Retinoic acid treatment for hyperpigmented lesions caused by inflammation of the skin in black patients. *N Engl J Med* 1993; 328(20):1486–1487.
- El Samahy MH, Ghaz MM, Ramzy N. Morphological investigation of chemical peel on photodamaged facial skin. *Int J Cosmet Sci* 1998; 20(5):269–282.
- Fain-Maurel MA. *Biologie de la cellule*. Ed Bréal, Rosny, 1994.
- Farnes SW, Setness PA. Retinoid therapy for aging skin and acne. *Postgrad Med* 1992; 92(6):191–196, 199–200.
- Fischer TC, Perosino E, Poli F, et al.; for the Cosmetic Dermatology European Expert Group. Chemical peels in aesthetic dermatology: an update 2009. *J Eur Acad Dermatol Venereol* 2009, Sept 8.
- Gilchrist BA. Retinoids and photodamage. *Br J Dermatol* 1992; 127(suppl 41):14–20.
- Giroud JP, Mathé G, Meyniel G. *Pharmacologie clinique*. In: Schmitt H, ed. *Eléments de pharmacologie*. 5th ed. 1590–1591.
- Griffiths CE, Goldfarb MT, Finkel LJ. Retinoic acid treatment of hyperpigmented lesions associated with photoaging in Chinese and Japanese persons. *J Am Acad Dermatol* 1994; 30(1):76–84.
- Hardman JG, Limbird LE, Gilman AG, eds. *Goodman & Gilman's The Pharmacological Basis of Therapeutics*. Vol 2, 8th ed. New York: Mc Graw Hill, 2001.
- Khunger N; IADVL Task Force. Standard guidelines of care for chemical peels. *Indian J Dermatol Venereol Leprol* 2008; 74 (suppl):S5–S12.
- Leterrier F, Gary-Bobo Cl. *Biologie membranaire, structure et dynamique des membranes biologiques*. Ed. des sciences et des arts, Hermann, 1989.
- Rapaport MJ, Kramer F. Exacerbation of facial herpes simplex after phenolic face peels. *J Dermatol Surg Oncol* 1984; 10(1):57–58.
- Schmitt D. *Biologie de la peau (INSERM U.346)*. Les éditions INSERM, 1995.
- Shalita A. Le vieillissement cutané et son traitement par la tretinoïne. *J Med Est et Chir Derm* 1988; 15 (60):313–316.
- Stegman SJ. A comparative histologic study of the effects of three peeling agents and dermabrasion on normal and sun-damaged skin. *Aesthetic Plast Surg* 1982; 6(3):123–135.

# Lasers and light sources for vascular and pigmented components of photoaging

Corinne Erickson and Robert A. Weiss

## INTRODUCTION

Photoaging related changes most commonly occur on the face; however, areas such as the chest and legs are also frequently involved. Two clinical manifestations of photoaging for which patients often present for treatment are vascular and pigmented lesions. Facial telangiectasias are the most common vascular lesion related to photoaging in Caucasians. In contrast, Asians with photodamage present more frequently with UV-induced pigmentation problems. The most common pigmentation concerns are lentigos, keratoses, and Hori's macules (1). This chapter will review treatment modalities of most of these common problems.

## VASCULAR LESIONS

The term telangiectasia refers to superficial cutaneous vessels visible to the human eye (2). These vessels measure 0.1 to 1.0 mm in diameter and represent a dilated venule, capillary, or arteriole (Fig. 55.1). The vessel type determines the clinical presentation of telangiectasias. Arteriolar telangiectasias are small in diameter, bright red in color, and do not protrude above the skin surface. Venule-derived telangiectasias are wider, blue in color, and often protrude above the skin surface. Telangiectasias arising at the capillary loop initially present as fine, red lesions but often enlarge and become purple or blue in color with time (3).

There are four classifications of telangiectasias based on clinical morphology: (i) simple or linear, (ii) arborizing, (iii) spider, and (iv) papular (3). Linear and arborizing telangiectasias with red coloration are very common on the face, particularly on the nose and midface regions. These lesions are also seen relatively frequently on the legs. In addition, patients experience enlargement of slightly larger venulectasias. These appear as purplish vessels on the cheeks, periorbital region, and vermilion. Papular telangiectasias are typically manifestations of genetic syndromes, such as Osler-Weber-Rendu syndrome, or occur in the setting of collagen vascular diseases. They are less frequently related to photoaging. Cherry hemangiomas are also seen that are small round red to purple dome-shaped vascular ectasias scattered anywhere on the face or body. All forms of telangiectasias are thought to occur through the release or activation of vasoactive substances under the influence of a variety of factors, such as anoxia, hormones, chemicals, infection, and physical factors such as UV radiation, with resultant capillary or venular neogenesis (4).

Spider telangiectasias of the face are most commonly seen in patients with fair skin of Fitzpatrick types I and II, indicative of this group's increased susceptibility to UV damage. Facial telangiectasias are especially common on the nasal alae, dorsal

nose, and mid cheeks and are probably due to UV-induced vessel wall weakness that leads to persistent arteriolar vasodilation. Damage to the surrounding connective and elastic tissue from chronic sun exposure or use of topical steroids further worsens these lesions. There is also definite familial or genetic component to the development of spider telangiectasias. Rosacea may be an accompanying condition.

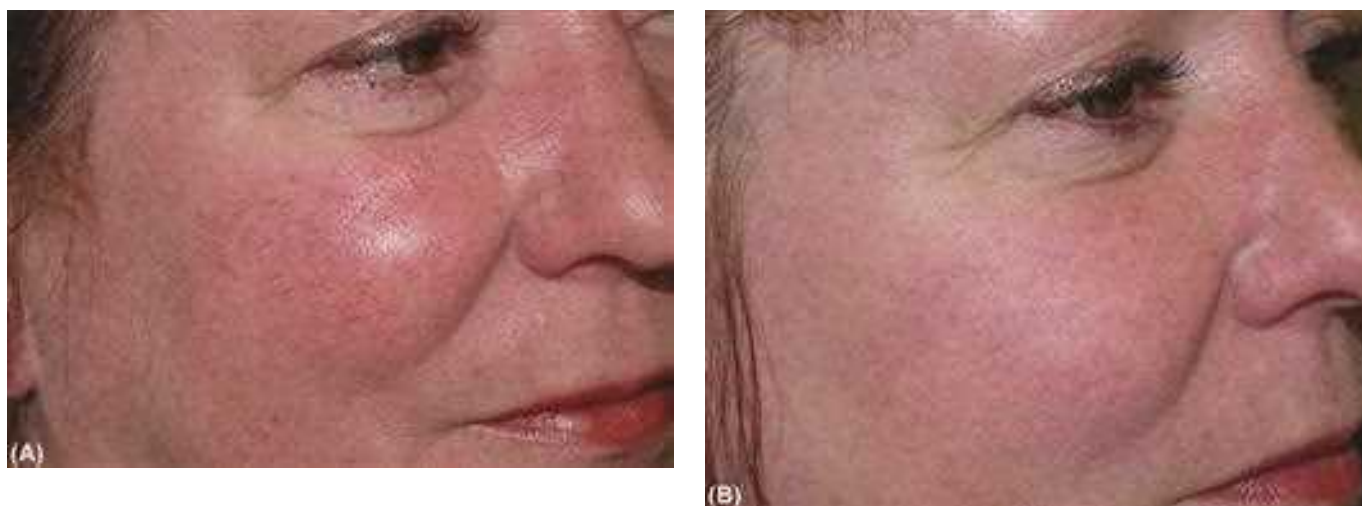
Whereas the cause of telangiectasias on the legs is predominantly hydrostatic pressure, facial telangiectasias appear to result from damage to the collagen of the vessel wall by sunlight. Sun exposure damages and weakens collagen with cumulative exposures, resulting in ectasia. Additionally, there is a relatively high incidence of rosacea on the face, which may have a prominent telangiectatic component (Fig. 55.2). Rosacea consists of frequent flushing associated with telangiectasias, papules, and pustules. It is the repeated flushing in rosacea, often caused by exercise, alcohol, and spicy food, which leads to the development of telangiectasias. Genetic factors also play a large role as the rosy cheek appearance passes from one generation to the next in individuals susceptible to rosacea. Aging of the skin, particularly photoaging, causes more telangiectasias as collagen breakdown ensues (5). Repeated trauma to the face will also induce localized erythema and ultimately vascular dilatation.

Fortunately, the treatment of facial telangiectasias is relatively safe and more predictable than treatment of telangiectasias on other sites, particularly the legs. This is attributable to several factors. One is the ability of facial skin to heal quickly with fewer propensities toward scarring when treated with a similar depth of injury than other locations. Treatment results are often seen much more quickly as healing is much faster on the well-oxygenated skin of the face. Facial vessels also have the advantage of a more uniform depth than the legs. The vascular walls themselves are much thinner and uniform, and hydrostatic pressure plays no major role in pathogenesis. Occasionally, arterial pressure is a factor as seen in spider angiomas with a small central arteriole. This arteriolar component must be considered when selected a treatment modality for these lesions. Treating the arteriolar-fed vessels with sclerotherapy incurs a higher risk of necrosis than when using laser or light to shut down the branches and shrink the arteriolar component.

Patients with telangiectasia of various types present for treatment primarily because of cosmetic concerns. Therefore, it is important that the procedure be relatively risk-free without unsightly scarring. Various modalities can be used to treat telangiectasia on the face or other regions. Several of these modalities will be discussed in more detail in this chapter, including electrodesiccation, sclerotherapy, and a variety of lasers including the pulse dye laser (PDL), long pulse dye



**Figure 55.1** (A) Telangiectasias on the cheek of a Caucasian female consistent with the early stages of photoaging. (B) The same patient following treatment with IPL has fewer visible vessels and smoother skin. IPL with double-pulse 570 nm filter, 2.4 milliseconds + 6 milliseconds pulse with 10 milliseconds delay, and a fluence of 29 J/cm<sup>2</sup> was used.



**Figure 55.2** Rosacea is thought to result in part from photoaging. IPL treatments reduce intensity and duration of flushing that worsens telangiectasias in rosacea. Before (A) and after (B) three treatments with Vasculight IPL (Lumenis, Santa Clara, California, U.S.) using a 550-nm filter, double pulse of 2.4 and 7 milliseconds, delay of 10 milliseconds, and a fluence of 27 to 29 J/cm<sup>2</sup>.

laser (LPDL), argon laser, frequency doubled neodymium:yttrium-aluminum-garnet laser (532Nd:YAG), intense pulsed light (IPL) in all its forms, and a variety of 1064 nm long-pulsed Nd:YAG lasers (1064Nd:YAG).

## ELECTROSURGERY

Electrodesiccation is commonly used to treat facial telangiectasia because the device is readily available and of relatively low cost, making it an accessible and affordable treatment worldwide. Electrodesiccation is a process in which heat is generated from

resistance of tissues to the passage of a highly damped current from a single electrode. Dehydration occurs in the tissue immediately adjacent to the needlepoint, and as cellular fluids are evaporated, tissue destruction results. The vessel must be cauterized or electrocoagulated every 2 to 3 mm with very low amperage current (1–2 A). Some degree of epidermal necrosis occurs due to the nonspecific nature of cauterization. Multiple treatments are typically necessary for successful treatment. Punctate white or pigmented scars may occur if excessive thermal damage occurs. Groove type scars along the nasal alae are the most common adverse effect of electrodesiccation.

Using the lowest effective fluence and the finest electrodes produces optimal results. Electrodes that are coated with Teflon so that only the tip of the electrode or one side of the electrode is exposed tend to provide the safest treatment. In addition, use of a bipolar current (with the patient grounded to a plate at a distance from the treated area) allows for effective treatment with a lower fluence. With bipolar treatment, the current passes through the cannulated vessel for several millimeters with relative selectivity. When performed with care, electrodesiccation is effective but is best reserved for the smallest of telangiectasia. This technique has been popularized by Kobayashi who reports excellent results (6).

Serious adverse effects from electrosurgery such as disturbance of pacemakers and implantable cardio defibrillators are extremely rare. To prevent disruption to electric currents in these devices, short bursts are recommended with minimal power settings. Rare instances of pacemaker interference with skipped beats and reprogramming have been reported in a survey of dermatologic surgeons performing electrocoagulation during cutaneous surgery. An incidence of 0.8 cases/100 years of surgical practice occurred but may not be representative of all patients undergoing electrodesiccation of telangiectasia (7).

## LASERS

There are multiple lasers available for destroying facial telangiectasia. These lasers act by selectively heating the vessel to cause its destruction through the absorption of laser energy by oxygenated and deoxygenated hemoglobin. The advantages and disadvantages of presently available lasers are described below.

Several factors must be considered in selecting an appropriate laser for telangiectasia treatment. In general, the choice of wavelength(s) and pulse duration are related to the type and size of target vessel treated. Deeper vessels require a longer wavelength to allow penetration to their depth. Pulse duration must be matched to vessel size, as the larger the vessel diameter, the longer the pulse duration required to effectively thermally damage the vessel. The relative importance of hemoglobin absorption peaks in green (541 nm), yellow (585–595 nm), and red to infrared (800–1000 nm) shifts as the depth and size of blood vessel changes. Absorption by hemoglobin in the long visible to near-infrared range appears to become more important for vessels over 0.5 mm and at least 0.5 mm below the skin surface (8).

It is important to note that while laser treatment of facial telangiectasias has yielded excellent results, the use of lasers to treat leg telangiectasias has been far less successful than sclerotherapy. This is likely related to insufficient vessel destruction by lasers, competition for the laser absorption from overlying melanin, and the failure of lasers to treat the increased hydrostatic pressure from the “feeding” venous system.

## CONTINUOUS WAVE LASERS

### Carbon Dioxide Laser

Carbon dioxide (CO<sub>2</sub>) lasers were used early on in an effort to obliterate telangiectatic vessels by means of precise vaporization without significant damage to adjacent tissue (9–11). However, because CO<sub>2</sub> laser light is so well absorbed by water in the epidermis and dermis overlying the blood vessel, nonspecific thermal injury is guaranteed regardless of whether pulsed or continuous wave sources are used (10). All reported studies demonstrate unsatisfactory cosmetic results (10,9,11). Treated

areas show multiple hypopigmented punctate scars with either minimal resolution of the treated vessel or neovascularization adjacent to the treatment site. Because of its nonselective action, the CO<sub>2</sub> laser has no advantage over the electrodesiccation needle and is associated with more adverse effects.

### Argon Laser

Argon (488 and 514 nm) and argon-pumped continuous wave dye lasers (515–590 nm) are well absorbed by hemoglobin and penetrate to the depth of mid-dermal vessels, over 1 mm into skin. Treatment parameters vary and laser powers of 0.8 W to 2.9 W, exposure times of 50 milliseconds, 0.2 seconds, 0.3 seconds, and continuous and spot sizes of 0.1 and 1 mm have been used. Though the success rate in treating facial telangiectasia has been reported to be good-to-excellent in 65% to 99% of patients treated (12–14), pitted and depressed scars, hypopigmentation, hyperpigmentation, and recurrence of veins have been noted (15–18).

Adverse healing consequences occur with the argon laser due to competition for absorption of its wavelength (411 and 514 nm) from epidermal melanin as well as radial diffusion and dissipation of heat from the target blood vessels secondary to long pulse durations. Both of these factors result in relatively nonspecific thermal destruction and this laser is not recommended.

### KTP 532 nm Green Lasers

Potassium titanyl phosphate (KTP) crystals are highly reliable, convenient to work with, and easily available to laser manufacturers. While the mechanisms of these devices vary, each produce millisecond domain pulses at 532 nm. Pulsing in milliseconds allows vessel coagulation to occur without producing purpura. The various KTP lasers available differ in the spot size that ranges from 0.5 to 4 mm in diameter.

Results of treatment of facial vessels have been excellent (19). Recent results with the KTP laser using larger spot sizes (3–5 mm) and longer pulse durations of 10 to 50 milliseconds at fluences of 14 to 20 J/cm<sup>2</sup> have been even more promising. Utilizing fluences between 12 and 20 J/cm<sup>2</sup> delivered with a 3- to 5-mm diameter spot size, a train of pulses is delivered over the vessel until spasm or thrombosis occurs. Although typically KTP is used with a 2-mm spot, 10 to 20 milliseconds pulse duration and 10 to 15 J/cm<sup>2</sup> of fluence and isolated red telangiectasias are treated along their course. Cooling appears to be of significant benefit in protecting the epidermis thus allowing use of higher, more effective fluences (20). One study comparing four different 532 nm lasers shows comparable 75% to 100% efficacy between them (21).

### Flashlamp Pumped-Pulsed Dye Laser

The traditional PDL (585 nm, 450 μseconds pulse duration) is highly effective in treating a variety of cutaneous vascular lesions, including PWS and facial telangiectasia. The original PDL was developed for the treatment of port wine stains in children, where the average vessel is superficial and has a diameter of 100 μm and an average depth of 0.46 mm. Modern day PDL is delivered entirely differently, using 595 nm, 1.5 to 20 milliseconds pulse durations and synchronized skin cooling with a cooling spray or airstream.

In preliminary animal studies in the rabbit ear vein, approximately 50% of vessels treated with an effective concentration of sclerosant demonstrated extravasated RBCs, while

after PDL treatment, extravasated RBCs were apparent in only 30% of vessels treated (22). Rabbit ear vein treatment with the PDL resulted in a relative decrease in perivascular inflammation compared to vessels treated with sclerotherapy alone.

The PDL treatment technique involves delivering a series of pulses overlapping 10% to 20%, tracing the vessels to be treated with a 2-, 3-, 5-, 7-, 10-mm or elliptical delivery spot, and treating an area of interlacing telangiectasia with overlapping spots to cover the involved area. Delivery energies range from 5.0 to 14.0 J/cm<sup>2</sup> depending on the spot size used and are adjusted according to vessel response. The end point is purpura or vessel spasm.

Purpura is a common occurrence after treatment with traditional PDL with short pulse durations, but is much less common with pulse durations longer than 6 milliseconds. Initial studies using the 0.45 milliseconds pulse duration FLPD laser demonstrated high efficacy but was complicated by purpura that lasted for one to two weeks (23). In this study, 182 patients treated with the 0.45 milliseconds pulse laser at 6 to 7.75 J/cm<sup>2</sup> with a 5-mm diameter spot size were evaluated. 76% to 100% clearance was obtained in 83.5% of patients with the remainder having 51% to 75% clearance.

A technique to increase efficacy and decrease purpura is to use double and triple pulses (pulse stacking) at subpurpuric fluences. Tanghetti used pulse stacking to increase efficacy on photoaging with reduced side effects but found that multiple treatments with or without pulse stacking had excellent results on the signs and symptoms of photoaging including telangiectasias (24).

### LONG-PULSE DYE LASERS

On the basis of theory of selective photothermolysis, the predicted pulse duration ideally suited for thermal destruction of vessels, the size of leg telangiectasia (0.1-several mm in diameter) is in the 1 to 50 milliseconds domain (25). Newest long pulsed dye lasers with variable pulse durations as long as 40 milliseconds (V-Beam Perfecta™, Syneron/Candela, Wayland, Massachusetts, U.S. and Cynergy™, Cynosure, Chelmsford, Massachusetts, U.S.) are now available. Each device uses a rhodamine dye to produce wavelengths of 585 to 595 nm. These longer pulse durations and longer wavelengths improve our ability to treat deeper, larger caliber vessels.

Newer FLPD lasers that extend the pulse duration to 1.5, 3, 6, 10, 20, and 40 milliseconds and use dynamic or continuous air cooling have eliminated most of the pain and have minimized purpura associated with the first generation FLPD lasers. Typical fluences of 10 J/cm<sup>2</sup> with a 10-millisecond spot size usually result in 90% resolution of facial telangiectasias in one treatment with minimal pain and purpura (Fig. 55.3). Improvement in rough texture and pigmentation of photoaging is also seen.

Treatment of leg telangiectasias with this method has not produced satisfactory results, even with the use of longer pulsing. In a single treatment of vessels less than 0.4 mm in diameter using the 595 nm, 1.5 milliseconds pulsed dye laser (Cynosure) and an experimental 595 nm, 4 milliseconds pulsed dye laser, clearing rates were not clinically significant with either device, and the rates of both hypopigmentation and hyperpigmentation were significant (26). Another study evaluated patients treated 3 times, 6 weeks apart, with the 595 nm, 1.5 milliseconds PDL (candela). While all patients experienced at least 50% clearing of the treated vessel, 50% of the treated



**Figure 55.3** Treatment with the long-pulsed dye laser (V-Star, Cynosure, Chelmsford, Massachusetts, U.S.) improved this patient's telangiectasias, skin texture, and pigmentation (2-millisecond duration, 2.5 J, 10-mm spot, and three passes). (A) Pretreatment. (B) After treatment.

areas became hyperpigmented and 20% hypopigmented (27). Despite advances in laser therapy, sclerotherapy remains the gold standard for treatment of leg telangiectasias.

### THE COPPER VAPOR LASER

The copper vapor laser operates at two specific wavelengths, 578 (yellow) and 511 nm (green) and delivers a "quasi-continuous wave" composed of pulsed laser light energy in 20 nanoseconds pulses at a frequency of 15,000 pulses per second. This train of pulses interacts with tissue in the same manner as a continuous beam because of the accumulation of heat with the large number of pulses delivered. Because of resulting thermal diffusion, it is necessary to electronically gate the pulse to a 20- to 50-millisecond duration.

These refinements should allow this laser to work within the thermal relaxation time of telangiectasia. When the laser is used without these refinements, it is somewhat safer and more effective than the argon laser for treatment of facial telangiectasia. It also has the advantage of leaving very minor superficial crusts overlying treated vessels in contrast to the very visible





**Figure 55.4** Larger facial veins can be treated with the 1064-nm Nd:YAG laser (Vasculight, Lumenis, Santa Clara, California, U.S.). (A) Pretreatment. (B) 50% improvement two months after treatment.

dark purpuric impact spots of the FLPD laser. A comparison of the copper vapor laser with the FLPD laser in adults with facial telangiectasia demonstrated no difference in efficacy but did show that the copper vapor caused crusting while the FPLD caused purpura (28).

### Long Pulse Nd:YAG 1064 nm

Long pulsed 1064 nm lasers have recently been developed in an effort to target deep, relatively large caliber cutaneous vessels. This wavelength achieves deep penetration and is not absorbed by melanin, thus allowing treatment of more darkly pigmented individuals. However, high energies must be utilized for adequate penetration. Only with sufficient fluence and facilitation of heat dissipation, the posterior wall of a larger diameter (1–2 mm) vessel filled with deoxygenated hemoglobin can be reached and heated.

The newer pulsed 1064 nm lasers have pulse durations between 1 and 200 milliseconds (Vasculight™ Lumenis, Santa Clara, California, U.S.; Cool Touch Varia™, CoolTouch Corp., Roseville, California, U.S.; Lyra™, Laserscope Lyra, San Jose, California U.S.; Coolglide™, Altus, Burlingame, California, U.S.). Large caliber vessels >0.5 mm in diameter respond best to these lasers; however, recent data suggests that by using smaller spots and higher fluences even small vessels will respond. In initial studies with a first-generation 1064 nm fixed 6 mm spot delivery handpiece, optimal settings were fluences of 80 to 120 J/cm<sup>2</sup> and single pulse durations of 10 to 30 milliseconds (29). Experience indicated an approximately 75% resolution of leg telangiectasias at three months using 16 milliseconds pulse durations with fluences of 130 to 140 J/cm<sup>2</sup> (29).

Larger violaceous vessels of the face may be treated with these devices (Fig. 55.4). The fluence must be lowered by 30% to 40% for facial vessels as compared to the legs. A recent study of facial telangiectasias and periorcular reticular veins showed excellent results in 17 patients using a cryogen spray cooled 1064 nm system. Greater than 75% improvement was observed in 97% of the treated sites (30).

It should be kept in mind that treatment with long pulse 1064 nm laser is relatively painful, and both cooling and topical

anesthesia should be employed to minimize discomfort. Stacked pulsing CANNOT be performed with 1064 nm as there is high risk of heat buildup and skin breakdown, 1064 nm should never be used faster than 1 Hz pulse rate, and pulse positioning should never be closer than 1 mm apart. For patient comfort, epidermal cooling can be contact cooling or cryogen spray that can be programmed both before and after the laser pulse. The concept behind the applying the spray after the cooling pulse is for “thermal quenching” (US Patent # 6451007, Koop, Baumgardener, and Weiss) of the heat released from larger vessels following the laser heating.

### IPL SOURCE

The high intensity pulsed light (IPL) source was developed as a device to treat ectatic blood vessels using noncoherent light emanating from a filtered flashlamp (Lumenis One™, Lumenis, Santa Clara, California, U.S.). Although Lumenis is the largest and most well known of the IPL device manufactures, other manufactures of pulsed light devices include Energis Technology, Swansea, U.K., marketing an Energis Elite IPL system for hair removal only, and Danish Dermatologic Development, Hoersholm, Denmark that markets the Ellipse system for hair and vascular indications. The Energis system is a low-output device, with 5 to 19 J/cm<sup>2</sup> output, spot size of 10 mm × 50 mm, pulse train length of 15 to 40 milliseconds, and pulses per train of 4 to 5. There is a fixed delay between pulses of 1.5 milliseconds. By comparison, the Lumenis device is a high-output device with up to 90 J/cm<sup>2</sup> output, spot size of 8 mm × 35 mm, variable pulse lengths of 2 to 40 milliseconds, and infinitely variable delay between pulses of 1 to 1000 milliseconds.

Selectivity for IPL is achieved primarily by manipulating pulse durations to match thermal relaxation times of vessels larger than 0.2 mm and by using filters to remove lower wavelengths of visible light. Fluence can be very high with the unit delivering up to 90 J/cm<sup>2</sup>. Sequential pulsing of 1 to 12 milliseconds duration separated and synchronized with 1 to 100 milliseconds rest intervals delivers wavelengths of 515 to 1000 nm. It is most commonly used with the 550 and 570 nm filters to deliver the yellow and red wavelengths and some infrared. The ability of IPL to produce a noncoherent light as a



**Figure 55.5** Poikilodermatous type of photoaging of the chest including telangiectasias and pigmentation. (A) Pretreatment of chest and neck areas. (B) Following one IPL treatment. Note the disappearance of cherry hemangiomas on the right side of the chest.

continuous spectrum longer than 550 nm was thought to have multiple advantages over a single wavelength laser system. These advantages include absorption by both oxygenated and deoxygenated hemoglobin and absorption by larger blood vessels located deeper in the dermis. In reality, the primary advantage has been larger spot size and relatively low incidence of purpura on facial telangiectasia.

For facial telangiectasia, our experience has been that the 550, 560, or 570 nm produce optimal results. When treating darker skin types and larger blood vessels, we choose a longer cutoff filter. For telangiectasia-predominant photoaging, the typical pulse durations are 2.4 milliseconds + 6.0 milliseconds with a 10-millisecond delay between pulses. The delay between pulses is increased to 20 to 30 milliseconds in darker skin types as they are more prone to thermal injury. Typical pulse durations are 2.4 milliseconds + 4.0 milliseconds (double pulse) with a 10-millisecond delay between the pulses for pigmentation predominant photoaging. Typical fluences range from 24 to 38 J/cm<sup>2</sup> again related to the sensitivity of the skin and the degree of epidermal cooling. To minimize nonspecific epidermal damage, the crystal is placed on a layer of ice-cold clear gel 2 to 3 mm in thickness for noncooled crystals (floating technique). When using the Quantum IPL with a thermoelectrically cooled crystal, a thin layer of gel is used with the crystal resting directly on the skin with the crystal at maximal cooling (direct contact technique).

Studies on the treatment of leg telangiectasia and poikiloderma of Civatte have proven the efficacy as well as limitations of IPL technology. Few studies have evaluated IPL efficacy purely on facial telangiectasia. Most studies with the IPL comment on its photorejuvenation effects that include elimination of lentigos, reduction of pore size, and minimization of fine wrinkles in addition to treatment of telangiectasia (Fig. 55.5). Results from studies evaluating the efficacy of IPL for treating telangiectasias have been consistently promising. Bitter reported that the IPL used in "FotoFacial settings" produced >75% improvement in telangiectasia in 38% of patients and >50% reduction in telangiectasia in 70% of patients (31). Negishi found a >75% improvement in telangiectasia

in 33% of her Japanese settings (similar to Bitter's except for a decrease in fluence and a longer delay time between the double pulses) (32). Her study showed 83% of patients had at least a 50% improvement in telangiectasia.

Another IPL device (Ellipse Flex, Danish Dermatologic Development, Hoersholm, Denmark) was used in 27 patients with facial telangiectasia. This IPL has a lower cutoff at 555 nm as well as an upper cutoff filter at 950 nm with a median wavelength at 705 nm delivered through a 10 mm × 48 mm crystal light guide. Fluences required to produce a slight bluing of the vessels ranged 13 to 22 J/cm<sup>2</sup>. Pulse durations were 10 milliseconds for vessels <0.4 mm in diameter and pulsed durations of 15 and 30 milliseconds were used for larger vessels. Patients received from one to four treatments with an average of 2.54 treatments. 83.4% of patients had greater than 50% clearing with 66.7% having greater than 75% clearance (33).

The development of the short pulse-long pulse protocol utilizing 2.4 to 3 milliseconds and 7 milliseconds pulses separated by a 10- to 20-millisecond delay employing the 560 or 570 nm filter has yielded the best results for leg veins using the IPL device. Response rates of 74% in two treatments with an 8% incidence of temporary hypo- or hyperpigmentation has been reported (34). By combining a shorter pulse (2.4–3 milliseconds) with a longer pulse (7–10 milliseconds), it is theoretically possible to ablate smaller and larger vessels overlying one another in the dermis. The shorter pulses are absorbed more selectively by smaller more superficial vessels, while the longer pulses are absorbed by the larger diameter, deeper vessels. New contact epidermal cooling devices improve treatment results by allowing larger fluences with less risk to the epidermis.

## THE ROLE OF COOLING

The concept of cooling the skin in an effort to protect the epidermis during laser treatment of dermal targets was first studied by Gilchrest (35) who incorporated the use of ice prior to argon laser treatment of port wine stains. Skin cooling during skin laser therapy offers multiple benefits, including cooling and protecting the epidermis, preventing other collateral

dermal damage, and also reducing the discomfort associated with treatment. Cooling is especially critical in the treatment of larger telangiectasia due to the high fluencies required for efficacy. By cooling the skin, collateral injury is limited.

Several cooling modalities have been used including water-cooled chambers applied directly to the skin through which the laser beam is directed, cooling coupling gels, and refrigerated spray cooling devices. Preliminary results suggest that cooling helps to spare epidermal damage, hence allowing use of higher fluencies and yielding more damage of the targeted vessels and achieving a greater degree of clearing per treatment (36,37). However, cooling has a minor role in the treatment of pigmented lesions.

### Pigmented Lesions

Pigmented lesions are another common manifestation of photo-damage for which patients often present to dermatologists for treatment. Sun damage induces pigmentation changes in several manners. In the development of ephelides (freckles), the pattern of melanin deposition is altered (38). Ephelides classically occur in a photodistributed pattern, favoring the face, shoulders, and extensor arms, and darken with increased sun exposure. Lentigos are the most common photoaging-associated pigmented lesions and occur because of UV-induced melanocyte proliferation. The treatment of ephelides and lentigos will be the focus of this section.

### Q-Switched Lasers

Several laser systems have been shown to be effective in the treatment of lentigines. These systems include the 510 nm pulsed dye laser, the frequency doubled Q-switched Neodymium:Yttrium-Aluminum-Garnet 532 nm (QS 532 nm Nd:YAG) laser, the Q-switched Ruby laser, and the QS Alexandrite laser (39) (Fig. 55.6). As in most aesthetic procedures, the risk of adverse effects is an important consideration. Dark-skinned patients have a higher epidermal melanin content and are more likely to develop complications such as hyperpigmentation. Studies of the use of Q-switched lasers in dark-skinned patients have indicated that the risk of post-inflammatory hyperpigmentation (PIH) is approximately 20% (40).

QS ruby and QS Alexandrite wavelengths are well absorbed by melanin. However, the greater depth of penetration can be a disadvantage because there is a potential for permanent follicular melanocytic damage causing leukotrichia when a high fluence is used. When Q-switched lasers have been compared to long pulsed lasers, interesting findings regarding optimal efficacy and adverse effects have been shown. An in vivo study of 34 patients compared a QS 532 nm Nd:YAG laser to a long pulse 532 nm Nd:YAG laser (41). Results showed that the long pulse 532 nm laser ( $6.5 \text{ J/cm}^2$ , 2-mm spot size, 2-millisecond pulse duration) resulted in a lower risk of PIH when used to treat lentigines in Asians.

### Q-Switching Versus Millisecond Pulse Durations

Q-switched lasers generate high-energy radiation with very short pulse duration. This produces intense energy that leads to a rapid rise in temperature ( $1000^\circ \text{C}$ ) within the target subcellular chromophore. As the laser pulse duration is shorter than the thermal relaxation time of the target, a temperature gradient develops between the target and its surrounding



**Figure 55.6** Solar lentigo. (A) Before treatment. (B) Following one treatment with Q-switched Ruby laser at  $4 \text{ J/cm}^2$ .

tissue (42). When the temperature gradient collapses, it generates localized shockwaves causing the fragmentation of its targets. This photomechanical reaction leads to melanosomal disruption that occurs after nanosecond pulse durations of Q-switching (43).

### IPL

Photothermal effects, such as those produced by the IPL, were initially considered more efficacious when treating lentigines. Some promoted the concept that the photomechanical effect of QS lasers was undesirable for lentigines, and this has been confirmed by a number of investigators (41,44). Use of IPL for photoaging in Asians has been shown to increase collagen and decrease melanin without significant adverse effects in the treatment areas and relatively high patient satisfaction rates (45). There have been few reports of IPL-induced long-term hyperpigmentation (46,47), although temporary hypopigmentation is a well-recognized side effect. To minimize risks of scarring, it is important to select a pulse duration that is shorter than the thermal relaxation time of the epidermis. The epidermal relaxation time is estimated to be approximately 10 milliseconds if the epidermal thickness is 100  $\mu\text{m}$  (48), so that pulse

durations of less than 10 milliseconds with IPL are preferred for pigmented lesions.

## SELECTING THE LASER

When treating epidermal pigmented lesions such as lentigenes, patients should be informed about advantages and disadvantages of each mode of treatment. IPL typically results in little downtime and may also improve rhytids. Lasers, however, may be the preferred choice for patients in terms of fewer treatments and cost-effectiveness. Test areas with two different devices may be performed. If a test spot clearance is satisfactory, without development of PIH, then it is best to use the device that performed best. Patients are advised that clearance may take one to four sessions. However, if PIH develops at any time during the treatment phase, treatment is stopped, hydroquinone or equivalent is applied daily, and the patient is followed until resolution of PIH occurs. Typically, we use IPL if multiple pigmented lesions are scattered around the face, but QS ruby if a few isolated lentigenes are targeted.

## PRETREATMENT AND POSTTREATMENT CONSIDERATIONS

One cannot overemphasize the importance of pretreatment skin preparation to patients planning to undergo laser or light treatment for pigmented components and vascular components of photoaging. The use of topical bleaching agents such as hydroquinone, vitamins C and E, and UVA/UVB sunscreens of SPF 30 or higher should be initiated two weeks prior to the laser/IPL surgery and then resumed five to seven days post treatment or when epidermal crusting resolves. Treatment should continue for at least six months after a course of treatment. Use of sunscreens should become a lifelong habit.

## SUMMARY

Treatment of vascular and pigmented lesions in adults can be very successful. Practically, all laser devices available in the visible light range, except for red, produce good results on facial vascular lesions. Q-switching is an important tool for treatment of pigmentation. Knowledge of the lesion type and differences in response by size and location can assist in selecting the procedure most likely to achieve successful results. Wavelengths of lasers may be fine tuned for size or color of individual telangiectasias. Although electrocautery is used frequently, a more selective method such as laser or IPL is usually a better choice with far less risks of scarring. Larger cavernous lesions may require deeper penetration of 1064 nm (infrared) wavelengths used cautiously. The benefit of IPL in photoaging is the smoothing of skin and reduction of irregular pigmentation in addition to treatment of vascular lesions. Considering the skin type of the patient, the nature of the lesion, and performing test areas when indicated can ultimately lead to an effective and safe treatment of pigmented and vascular lesions due to photoaging.

## REFERENCES

- Chan H. Treatment of photoaging in Asian skin. In: Rigel Darrel S, Weiss Robert A, Lim HW, et al., eds. *Photoaging*. New York: Marcel Dekker, Inc, 2004:343-364.
- Merlen JF. [Red telangiectasis, blue telangiectasis]. *Phlebologie* 1970; 23(2):167-174.
- Weiss RA, Goldman MP. Advances in sclerotherapy. *Dermatol Clin* 1995; 13(2):431-445.
- Goldman MP, Bennett RG. Treatment of telangiectasia: a review. *J Am Acad Dermatol* 1987; 17:167-182.
- Glogau RG. Aesthetic and anatomic analysis of the aging skin. *Semin Cutan Med Surg* 1996; 15(3):134-138.
- Kobayashi T. Electrosurgery using insulated needles: treatment of telangiectasias. *J Dermatol Surg Oncol* 1986; 12(9):936-942.
- el-Gamal HM, Dufresne RG, Saddler K. Electrosurgery, pacemakers and ICDs: a survey of precautions and complications experienced by cutaneous surgeons. *Dermatol Surg* 2001; 27(4): 385-390.
- Smithies DJ, Butler PH. Modelling the distribution of laser light in port-wine stains with the Monte Carlo method. *Phys Med Biol* 1995; 40(5):701-731.
- Apfelberg DB, Smith T, Maser MR, et al. Study of three laser systems for treatment of superficial varicosities of the lower extremity. *Lasers Surg Med* 1987; 7(3):219-223.
- Landthaler M, Haina D, Waidelech W, et al. Laser therapy of venous lakes (Bean-Walsh) and telangiectasias. *Plast Reconstr Surg* 1984; 73(1):78-83.
- Apfelberg DB, Maser MR, Lash H, et al. Use of the argon and carbon dioxide lasers for treatment of superficial venous varicosities of the lower extremity. *Lasers Surg Med* 1984; 4(3):221-231.
- Apfelberg DB, McBurney E. Use of the argon laser in dermatologic surgery. In: Ratz JL, ed. *Lasers in Cutaneous Medicine and Surgery*. Chicago: Year Book Medical Publishers, 1986.
- Apfelberg DB, Maser MR, Lash H. Treatment of nevi aranei by means of an argon laser. *J Dermatol Surg Oncol* 1978; 4:172.
- Achauer BM, Vander Kam VM. Argon laser treatment of telangiectasia of the face and neck: 5 years' experience. *Lasers Surg Med* 1987; 7(6):495-498.
- Apfelberg DB, Smith T, Maser MR, et al. Dot or pointillistic method for improvement in results of hypertrophic scarring in the argon laser treatment of port-wine hemangiomas. *Lasers Surg Med* 1987; 6:552.
- Dixon JA, Huether S, Rotering RH. Hypertrophic scarring in argon laser treatment of port-wine stains. *Plast Reconstr Surg* 1984; 73:771.
- Lyons GD, Owens RE, Mouney DF. Argon laser destruction of cutaneous telangiectatic lesions. *Laryngoscope* 1981; 91:1322.
- Dolsky RL. Argon laser skin surgery. *Surg Clin North Am* 1984; 64:861.
- Keller GS. KTP laser offers advances in minimally invasive plastic surgery. *Clin Laser Mon* 1992; 10(9):141-144.
- Adrian RM. Treatment of leg telangiectasias using a long-pulse frequency-doubled neodymium:YAG laser at 532 nm. *Dermatol Surg* 1998; 24(1):19-23.
- Goldberg DJ, Meine JG. A comparison of four frequency-doubled Nd:YAG (532 nm) laser systems for treatment of facial telangiectasies. *Dermatol Surg* 1999; 25(6):463-467.
- Goldman MP, Fitzpatrick RE. Pulsed-dye laser treatment of leg telangiectasia: with and without simultaneous sclerotherapy. *J Dermatol Surg Oncol* 1990; 16:338-344.
- Ruiz-Esparza J, Goldman MP, Fitzpatrick RE, et al. Flash lamp-pumped dye laser treatment of telangiectasia. *J Dermatol Surg Oncol* 1993; 19:1000-1003.
- Tanghetti EA, Sherr EA, Alvarado SL. Multipass treatment of photodamage using the pulse dye laser. *Dermatol Surg* 2003; 29(7):686-690.
- Dierickx CC, Casparian JM, Venugopalan V, et al. Thermal relaxation of port-wine stain vessels probed in vivo: the need for 1-10-millisecond laser pulse treatment. *J Invest Dermatol* 1995; 105(5): 709-714.
- Alora MB, Herd RH, Szabo E. Comparison of the 595 nm long pulse (1.5 ms) and the 595 nm ultra-long pulse (4 ms) laser in the treatment of leg veins. *Lasers Surg Med* 1998; 10(suppl):38.
- Grossman MC, Bernstein LJ, Laughlin S. Treatment of leg veins with a long pulse tunable dye laser. *Lasers Surg Med* 1996; 8 (suppl):35.

28. Waner M, Dinehart SM, Wilson MB, et al. A comparison of copper vapor and flashlamp pumped dye lasers in the treatment of facial telangiectasia. *J Dermatol Surg Oncol* 1993; 19:992-998.
29. Weiss RA, Weiss MA. Early clinical results with a multiple synchronized pulse 1064 nm laser for leg telangiectasias and reticular veins. *Dermatol Surg* 1999; 25(5):399-402.
30. Eremia S, Li CY. Treatment of leg and face veins with a cryogen spray variable pulse width 1064-nm Nd:YAG laser—a prospective study of 47 patients. *J Cosmet Laser Ther* 2001; 3(3):147-153.
31. Bitter PH. Noninvasive rejuvenation of photodamaged skin using serial, full-face intense pulsed light treatments. *Dermatol Surg* 2000; 26(9):835-842.
32. Negishi K, Wakamatsu S, Kushikata N, et al. Full-face photo-rejuvenation of photodamaged skin by intense pulsed light with integrated contact cooling: initial experiences in Asian patients. *Lasers Surg Med* 2002; 30(4):298-305.
33. Bjerring P, Christiansen K. Intense pulsed light source for treatment of small melanocytic nevi and solar lentigines. *J Cutan Laser Ther* 2000; 2(4):177-181.
34. Weiss RA, Weiss MA, Marwaha S, et al. Non-coherent filtered flash-lamp intense pulsed light source for leg telangiectasias: long pulse durations for improved results. *Lasers Surg Med* 1998; 10(suppl):40.
35. Gilchrist BA, Rosen S, Noe JM. Chilling port wine stains improves the response to argon laser therapy. *Plast Reconstr Surg* 1982; 69(2): 278-283.
36. Chess C, Chess Q. Cool laser optics treatment of large telangiectasia of the lower extremities. *J Dermatol Surg Oncol* 1993; 19:74-80.
37. Waldorf HA, Alster TS, McMillan K, et al. Effect of dynamic cooling on 585-nm pulsed dye laser treatment of port-wine stain birthmarks. *Dermatol Surg* 1997; 23(8):657-662.
38. Chen John ZS, Geronemus RG. Treatment of Photoaging-Associated Pigmentary Changes. In: Rigel DS, Weiss RA, Lim HW, et al. eds. *Photoaging*. New York: Marcel Dekker, 2004:329-342.
39. Kilmer SL. Laser eradication of pigmented lesions and tattoos. *Dermatol Clin* 2002; 20(1):37-53.
40. Murphy MJ, Huang MY. Q-switched ruby laser treatment of benign pigmented lesions in Chinese skin. *Ann Acad Med Singapore* 1994; 23(1):60-66.
41. Chan HH, Fung WK, Ying SY, et al. An in vivo trial comparing the use of different types of 532 nm Nd:YAG lasers in the treatment of facial lentigines in Oriental patients. *Dermatol Surg* 2000; 26(8): 743-749.
42. Anderson RR, Parrish JA. Selective photothermolysis: precise microsurgery by selective absorption of pulsed radiation. *Science* 1983; 220(4596):524-527.
43. Anderson RR, Margolis RJ, Watanabe S, et al. Selective photothermolysis of cutaneous pigmentation by Q-switched Nd: YAG laser pulses at 1064, 532, and 355 nm. *J Invest Dermatol* 1989; 93(1): 28-32.
44. Rashid T, Hussain I, Haider M, et al. Laser therapy of freckles and lentigines with quasi-continuous, frequency-doubled, Nd:YAG (532 nm) laser in Fitzpatrick skin type IV: a 24-month follow-up. *J Cosmet Laser Ther* 2002; 4(3-4):81-85.
45. Li YH, Wu Y, Chen JZ, et al. A split-face study of intense pulsed light on photoaging skin in Chinese population. *Lasers Surg Med* 2010; 42(2):185-191.
46. Lin JY, Chan HH. Pigmentary disorders in Asian skin: treatment with laser and intense pulsed light sources. *Skin Therapy Lett* 2006; 11(8):8-11.
47. Kawada A, Shiraishi H, Asai M, et al. Clinical improvement of solar lentigines and ephelides with an intense pulsed light source. *Dermatol Surg* 2002; 28(6):504-508.
48. Anderson RR, Parrish JA. The optics of human skin. *J Invest Dermatol* 1981; 77(1):13-19.

# An easy method to assess the antioxidative capacity of topical formulations

Hongbo Zhai and Howard I. Maibach

## INTRODUCTION

Oxidation is a chemical reaction that transfers electrons from a substance to an oxidizing agent. Oxidation reactions can produce free radicals, which start chain reactions that damage cells. Exposure to ultraviolet radiation (UVR), air pollutants, chemical oxidants, and aerobic microorganisms may damage the skin (1,2). In particular, reactive oxygen species (ROS) are considered a likely contributor to skin aging, cancer, and certain skin disorders (1,3,4). Fortunately, natural defense systems in healthy skin can protect against exogenous oxidative stress. But, excessive free radical attack (such as overexposure to UVR) can overwhelm cutaneous antioxidant capacity, leading to oxidative damage and ultimately to skin cancer, immunosuppression, and premature skin aging (1–4). Therefore, supplying exogenous antioxidants to the endogenous antioxidant system may prevent or minimize ROS-induced photoaging (4,5). This is why topical products with antioxidant properties have proliferated worldwide.

Recently, *in vitro* and *in vivo* methods have been utilized for the evaluation of antioxidant capacity (4–6). Most are based on the measurement of the relative abilities of antioxidants to scavenge radicals in comparison with the antioxidant potency of a standard antioxidant compound. However, some technologies require complicated performance and are time-consuming or expensive. We introduced a rapid, accurate, and easy method to quantify the antioxidative capacity with a sensitive photochemiluminescence device (7–9).

## PHOTOCHEMILUMINESCENCE DEVICE

A photochemiluminescence device, Photochem<sup>®</sup> (Analytik Jena AG, Jena, Germany, and Analytik Jena USA, Inc., Texas, U.S.), was utilized. Its principle is briefly described: Defined free radicals (superoxide anion radicals) are generated in the measuring system by the exposure of a photosensitizer to a UV-light source. The free radicals are detected by their reaction with a chemiluminogenic substance and the measurement of the emitted light. The light flashes are detected in the Photochem by a photomultiplier. These generated radicals are partially scavenged by reaction with the sample antioxidants and remaining radicals are quantified by the above described detection principle. The results are presented in equivalent concentration units of Trolox<sup>®</sup> (synthetic vitamin E) for lipid-soluble substances or ascorbic acid for water-soluble substances. Several concentrations of these standard compounds are used to establish a calibration curve and the detector signal of each run is monitored for 180 seconds. For measurements of the integral antioxidative capacity of lipid-soluble (ACL) antioxidants, an

ACL kit was used (Analytik Jena AG, Jena, Germany, and Analytik Jena USA, Inc. Texas, U.S.).

## TESTING TOPICAL FORMULATIONS

A vitamin E-containing oil-in-water emulsion with a 22.5% oil content for facial skin care (Sebamed<sup>®</sup> cream, Sebapharma GmbH & Co., Boppard, Germany) and its vehicle control were tested. The tested emulsion contains (INCI terminology): aqua, petrolatum, myreth-3 myristate, glycerin, cetearyl alcohol, tocopheryl acetate, cetareth-20, dimethicone, sodium PCA, sodium citrate, sodium carbomer, parfum, benzyl alcohol, methylparaben, propylparaben. The active ingredient was 2.3% vitamin E. The vehicle control was identical with the exception of the deletion of vitamin E.

## SAMPLE PREPARATION

Sample was made at a 5% concentration as follows: 37.5 mg of sample was placed into a 2.0 mL flat top microcentrifuge tube (Fisher Scientific, Pittsburgh, Pennsylvania, U.S.), to which 750  $\mu$ L of butanol (HPLC grade) (Fisher Scientific, Fair Lawn, New Jersey, U.S.) was added. The mixture was shaken with a vortex (Scientific Industries, Inc., Bohemia, New York, U.S.) vigorously for 30 seconds. After centrifugation for 5 minutes at 10,000 rpm, the supernatant was collected and transferred into a new microfuge tube through a 0.45  $\mu$ m filter (Osmonics, Inc., Minnetonka, Minnesota, U.S.).

## PROCEDURE FOR SAMPLE ANALYSIS

Analyses are performed according to the standard protocol with a modification (7). Six equal aliquots of each testing sample were analyzed. Ratio of the assay mixture was 50  $\mu$ L: 2300  $\mu$ L: 200  $\mu$ L: 25  $\mu$ L (sample: ACL-diluent: reaction buffer: photosensitizer and detection reagent work solution, respectively). A light emission curve was recorded during 180 seconds, and inhibition was the evaluation parameter of antioxidant activity. An exemplary light emission curve is shown in Figure 56.1. Amount of antioxidative substances were calculated by synthetic vitamin E used as standard to establish a calibration curve and expressed as nmol equivalents in antioxidant activity of vitamin E. Further details of measuring method and principles of photochemiluminescence analysis are found elsewhere (10–13).

The quantity of antioxidant capacity for the vitamin E-containing formulation and its vehicle control were  $2.28 \pm 0.05$  and  $0.16 \pm 0.03$ , respectively. The vitamin E-containing

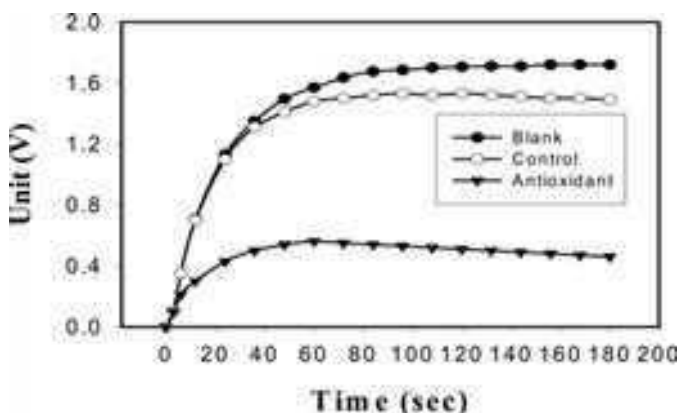


Figure 56.1 Exemplary light emission curve.

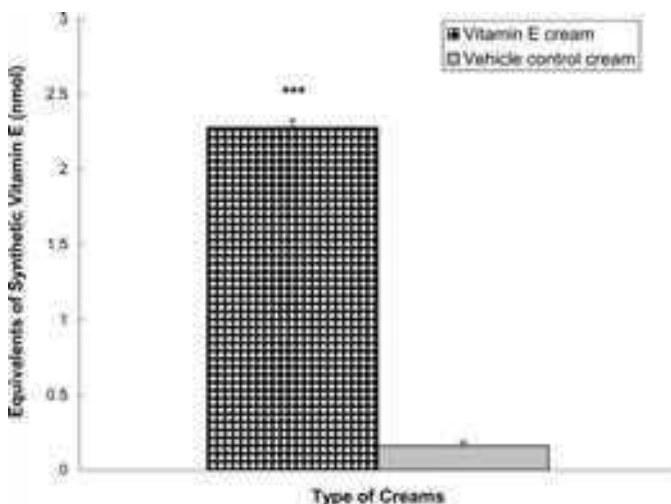


Figure 56.2 Antioxidant capacity that equivalents of synthetic vitamin E (nmol). Data were expressed as the means  $\pm$  SD. Statistical differences in comparison to the vehicle control indicated by \*\*\* $p < 0.001$ .

formulation showed a markedly significant ( $p < 0.001$ ) effect of antioxidant over its vehicle control (Fig. 56.2).

## DISCUSSION

Antioxidants are often found in skin care products claiming to decrease photoaging and reverse photodamage. These topical products may contain enzymatic and/or nonenzymatic antioxidants. However, vitamin E is a common component in these formulations. Its antioxidant effect has been documented (1,3,4,7,8,14–16). From our method, tested vitamin E formulation has demonstrated its superior antioxidant effect over its vehicle control.

Photochemiluminescence analysis provides advantages over the other methodologies: simple, quick, sensitive, econo-

mical, convenient, and reliable. It may detect the antioxidative capacities of even low concentrations of antioxidant. We suggest it may act as a screening method; keep in mind that the method and those data were generated from an in vitro experiment. Actual antioxidant effects of antioxidant-based formulation candidates should also be evaluated in vivo in man. Additionally, basic requirements for a scientific paper reporting antioxidant testing are recommended (17).

## REFERENCES

1. Thiele JJ, Dreher F, Packer L. Antioxidant defense systems in skin. In: Elsner P, Maibach HI, eds. *Cosmeceuticals, Drugs vs. Cosmetics*. New York: Marcel Dekker, 2000:145–187.
2. Thiele JJ. Oxidative targets in the stratum corneum. A new basis for antioxidative strategies. *Skin Pharmacol Appl Skin Physiol* 2001; 14(suppl 1):87–91.
3. Steenvoorden DP, van Henegouwen GM. The use of endogenous antioxidants to improve photoprotection. *J Photochem Photobiol B* 1997; 41:1–10.
4. Dreher F, Maibach HI. Protective effects of topical antioxidants in humans. In: Thiele JJ, Elsner P, eds. *Oxidants and Antioxidants in Cutaneous Biology*. Basel: Karger, 2001:157–164.
5. Stäb F, Wolber R, Blatt T, et al. Topically applied antioxidants in skin protection. *Methods Enzymol* 2000; 319:465–478.
6. Kohen R. Skin antioxidants: their role in aging and in oxidative stress—new approaches for their evaluation. *Biomed Pharmacother* 1999; 53:181–192.
7. Zhai H, Choi MJ, Arens-Corell M, et al. A rapid, accurate, and facile method to quantify the antioxidative capacity of topical formulations. *Skin Res Technol* 2003; 9:254–256.
8. Zhai H, Behnam S, Villarama CD, et al. Evaluation of the antioxidant capacity and preventive effects of a topical emulsion and its vehicle control on the skin response to UV exposure. *Skin Pharmacol Physiol* 2005; 18:288–293.
9. Zhai H, Cordoba-Diaz M, Wa C, et al. Determination of the antioxidative capacity of an antioxidant complex and idebenone: an in vitro rapid and sensitive method. *J Cosmet Dermatol* 2008; 7:96–100.
10. Popov IN, Lewin G. Photochemiluminescent detection of antiradical activity. IV: testing of lipid-soluble antioxidants. *J Biochem Biophys Methods* 1996; 11:1–8.
11. Popov IN, Lewin G. Photochemiluminescent detection of antiradical activity: II. Testing of nonenzymic water-soluble antioxidants. *Free Radic Biol Med* 1994; 17:267–271.
12. Lewin G, Popov I. Photochemiluminescent detection of antiradical activity. III: a simple assay of ascorbate in blood plasma. *J Biochem Biophys Methods* 1994; 28:277–282.
13. Popov I, Lewin G. Antioxidative homeostasis: characterization by means of chemiluminescent technique. *Methods Enzymol* 1999; 300: 437–456.
14. Fuchs J. Potentials and limitations of the natural antioxidants RRR- $\alpha$ -tocopherol, L-ascorbic acid and beta-carotene in cutaneous photoprotection. *Free Radic Biol Med* 1998; 25:848–873.
15. Dreher F, Gabard B, Schwindt DA, et al. Topical melatonin in combination with vitamins E and C protects skin from ultraviolet-induced erythema: a human study in vivo. *Br J Dermatol* 1998; 139: 332–339.
16. Darr D, Dunston S, Faust H, et al. Effectiveness of antioxidants (vitamin C and E) with and without sunscreens as topical photoprotectants. *Acta Dermatol Venereol* 1996; 76:264–268.
17. Verhagen H, Aruoma OI, van Delft JH, et al. The 10 basic requirements for a scientific paper reporting antioxidant, antimutagenic or anticarcinogenic potential of test substances in in vitro experiments and animal studies in vivo. *Food Chem Toxicol* 2003; 41: 603–610.

# The antioxidative capacity of topical emulsion on ultraviolet exposure

Hongbo Zhai and Howard I. Maibach

## INTRODUCTION

Skin, as the most important protective layer, is directly and frequently exposed to oxidative stress. Ultraviolet radiation (UVR) is recognized as the most exogenous oxidative factor to cause the skin problems (1). Healthy skin possesses an antioxidant defense system against oxidative stress (2,3). However, overexposure to UVR may overwhelm cutaneous antioxidant capacity, leading to cell damage and ultimately to skin cancer, immunosuppression, and premature skin aging (1-5). Supplying the exogenous antioxidants may play a key role in preventing or minimizing UVR-induced photoaging (4-11). Antioxidants are often formulated in skin care products that supposedly to decrease photoaging and reverse photodamage. These topical products may contain enzymatic and/or non-enzymatic antioxidants. Vitamin E is the collective name for an eight related tocopherols and tocotrienols, which are fat-soluble antioxidant vitamins. Of these,  $\alpha$ -tocopherol has been most studied as it has the highest bioavailability, with the body preferentially absorbing and metabolizing this form and hence it has been considered as a key indicator for the response of skin to oxidative stress (12).

One rapid, accurate, and facile method to quantify the antioxidative capacity of topical formulations in vitro and in vivo on human skin has been presented (13-15). This chapter highlights on the study of determination of antioxidative capacity of a topical skin care emulsion versus its vehicle in vivo on human skin that was exposed to UVR by utilizing a photochemiluminescence device and biophysical methods (14).

## MATERIALS AND METHODS

Healthy Caucasians with skin types were II or III (12,16) were studied. Subjects were instructed not to apply topical products to the test sites for one week prior to and during study. An oil-in-water vitamin E containing formulation (pH = 5.5) and its vehicle control were tested in a randomized and double blinded manner.

### Determination of Individual Minimal Erythema Dose

The flexor aspects of both forearms of subjects were designed for testing area. Prior to the study day 1, one forearm of each subject was exposed to an ultraviolet (UV) light (radiation source) for 30 seconds to three minutes to induce the minimal erythema dose (MED). To perform this, a template (black cloth) containing 6 square size cutout was made, each square cutout being 1 cm<sup>2</sup>. The template was taped onto one forearm of the volunteers. All cutouts were shielded except for cutout 1, which was exposed to UV radiation of 1.2 mW/cm<sup>2</sup> at a distance of

20 cm for 30 seconds. All cutouts were subsequently shielded except for cutout 2, which received UV radiation for 60 seconds. The remaining cutouts received UV radiation for 90, 120, 150, and 180 seconds, respectively. The doses were 36 to 216 mJ/cm<sup>2</sup> for exposure times between 30 and 180 seconds. The MED was determined after 24 hours post UV exposure. Details of this method are described elsewhere (11,16), and one MED was used in this study.

### Evaluation of Skin Response

The following measurements were used to evaluate the UV-induced skin response at baseline, day 2, and day 3 post UV exposures.

Visual scores (VS) assessment of the test sites were performed by one investigator according to the scale: (1) 0 = no redness; 1 = slight redness with a blurred boundary; 2 (= 1 MED) = moderate redness with a sharp boundary; 3 = intense redness; and 4 = fiery redness with edema.

Transepidermal water loss (TEWL) was assessed by a closed evaporimeter (Vapometer SWL-3, Delfin Technologies Ltd., Kuopio, Finland). TEWL documents integrity of stratum corneum (SC) water barrier function and is a sensitive indicator of skin water barrier alteration (17). The measuring principle and standard guidelines are published (18,19). The values of TEWL were expressed as g/m<sup>2</sup>/hr.

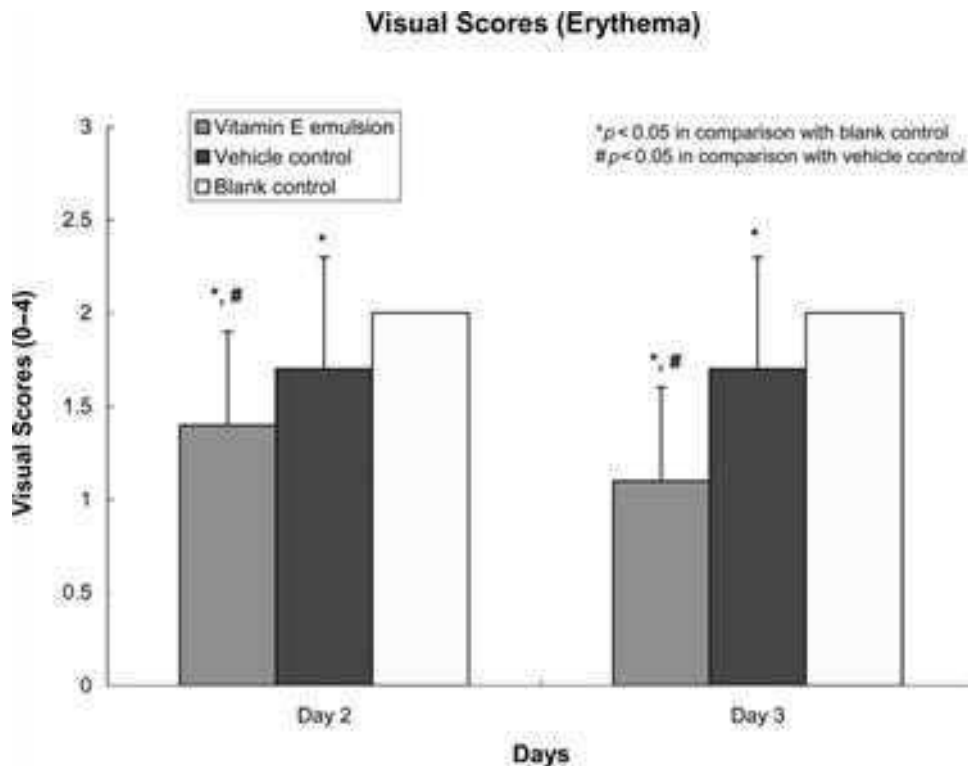
Blood flow volume (BFV) was measured by the use Laser Blood Flow Monitor MBF3D (Moor Instruments, Axminster, Devon, U.K. and Acaderm, Inc., Menlo Park, California, U.S.) to observe the blood flux of test sites. Details and standard guidelines for use were utilized (17,20,21). The values of BFV were expressed as arbitrary units (AU).

Skin color ( $a^*$  value) was quantified by using a colorimeter (Minolta CR-300, Osaka, Japan and Acaderm, Inc., Menlo Park, California, U.S.). The  $a^*$  value represents the color spectrum from total green to pure red and is known to correlate closely with erythema quantification (17,22,23). The values of  $a^*$  were expressed as AU.

Skin capacitance was measured by a Corneometer (CM 820, Courage+Khazaka, Cologne, Germany and Acaderm, Inc., Menlo Park, California, U.S.). Capacitance is a parameter for SC hydration. Details of the methods are described elsewhere (24,25). The values of capacitance were expressed as AU.

The measurements were conducted in a room with daily ranges of relative humidity (RH) from 58.9 ± 2.0% and temperature from 19.9 ± 0.8°C. These values (RH and degree centigrades) were recorded during experimental period. Each subject was rested at least 30 minutes for acclimation before measurements.





**Figure 57.1** Visual scores (erythema) at day 2 and day 3 post ultraviolet exposure. Data were expressed as the means  $\pm$  SD.

### Treatment and Irradiation Procedure

At study day 1, measurements of TEWL,  $a^*$ , BFV, and skin capacitance were taken at three test sites ( $1.5 \text{ cm}^2/\text{site}$ ) on the opposite forearm of each subject. Following measurements, two coded test emulsions were applied to two predesigned test sites. Thirty minutes later, these test sites on this forearm were exposed to an UV light to induce the MED. One untreated site (without emulsions) was served as a blank control. During UV exposure, forearms were protected by a black cloth except the test sites. Visual scoring and instrumental measurements were recorded after 24 hours of MED induction and 48 hours thereafter.

At day 3, after completing instrumental measurements, each test site was stripped with a proprietary adhesive tape disk (D-squame<sup>®</sup>, Cuderm Corporation, Dallas, Texas, U.S.) for three consecutive times. The tape disk was placed on the each test site with forceps, utilizing gloved hands. The tape disk was pressed onto the skin using a customized constant weight roller to the surface of the tape uniformly over its entire area for an approximately five seconds. The pressure was then removed and the tape disk was peeled from the skin with forceps in a unidirectional manner for all sites. Immediately after tape stripping, each tape disk was placed into a glass scintillation vial. These tape disks were quantified for antioxidant capacity using a photochemiluminescence device (Photochem<sup>®</sup>, Analytik Jena AG, Jena, Germany and Analytik Jena USA, Inc., Spring, Texas, U.S.). Details of measuring method and principles of photochemiluminescence analysis are found elsewhere (13–15,26–29).

### RESULTS VS

Vitamin E emulsion and vehicle control significantly ( $p < 0.05$ ) suppressed VS as compared with blank control at day 2 and day 3 post UV exposure. However, vitamin E emulsion showed significantly ( $p < 0.05$ ) lower VS where compared with vehicle control at day 2 and day 3 post UV exposure (Fig. 57.1).

### $a^*$ Values

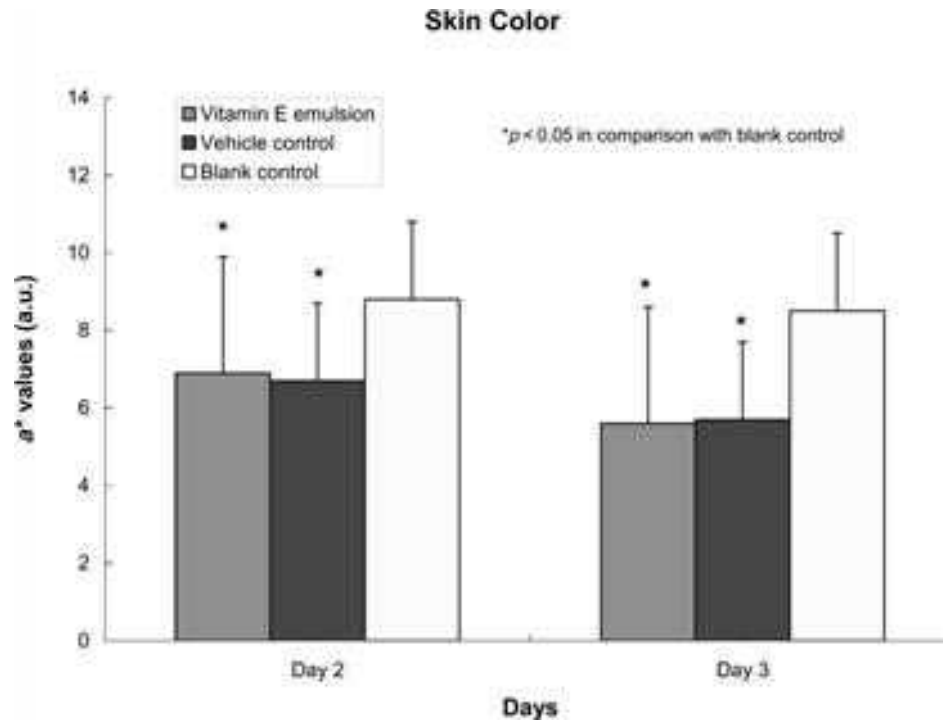
Vitamin E emulsion and its vehicle control significantly ( $p < 0.05$ ) diminished  $a^*$  values where compared with blank control at day 2 and day 3 post UV exposure (Fig. 57.2). There was no statistical difference between those two emulsions at each time point.

### BFV

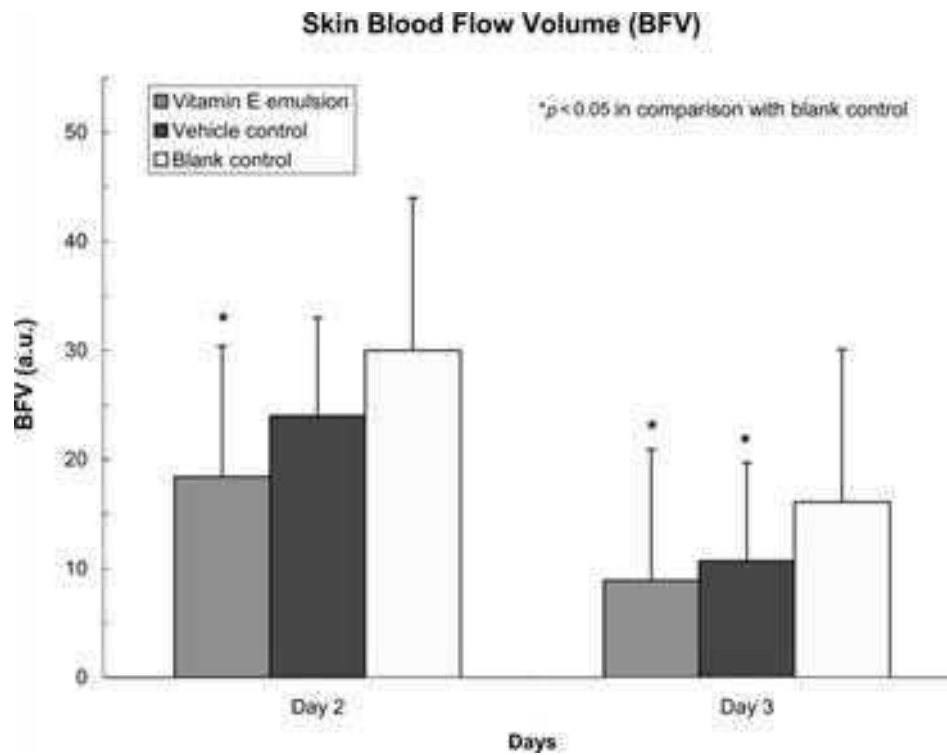
At day 2 post UV exposure, only vitamin E emulsion significantly ( $p < 0.05$ ) reduced BFV as compared with blank control. Vitamin E emulsion and its vehicle control showed significant ( $p < 0.05$ ) reduction of BFV as compared with blank control at day 3 post UV exposure (Fig. 57.3). There was no statistical difference between those two emulsions at either time point.

### TEWL

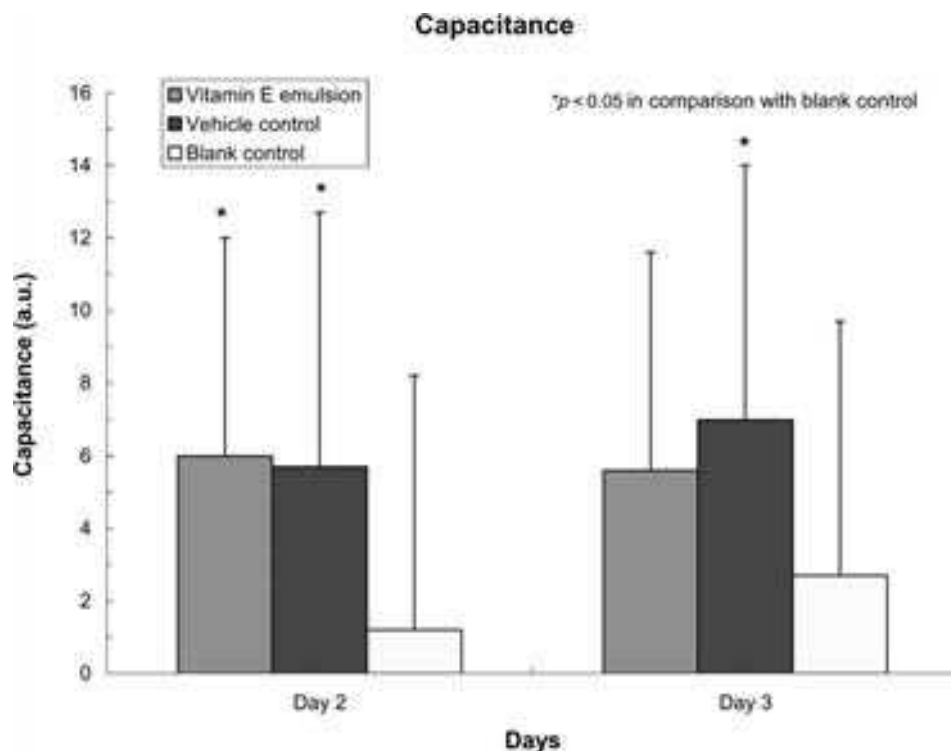
There was no statistical difference between those three tested sites at any time point.



**Figure 57.2** Skin color ( $a^*$  values) at day 2 and day 3 post ultraviolet exposure. Data were expressed as the means  $\pm$  SD.



**Figure 57.3** Skin blood flow volume at day 2 and day 3 post ultraviolet exposure. Data were expressed as the means  $\pm$  SD.



**Figure 57.4** Skin capacitance at day 2 and day 3 post ultraviolet exposure. Data were expressed as the means  $\pm$  SD.

### Capacitance

Vitamin E emulsion and its vehicle control significantly ( $p < 0.05$ ) increased skin capacitance as compared with blank control at day 2 post UV exposure (Fig. 57.4). At day 3 post UV exposure, only vehicle control showed significantly ( $p < 0.05$ ) increased values of capacitance in comparison with blank control. There was no statistical difference between those two emulsions at either time point.

### Antioxidant Capacity Analysis

In analyses with stripping 1, vitamin E emulsion and blank control showed significantly ( $p < 0.05$ ) higher quantity of antioxidant capacity than vehicle control. However, there was no statistical difference between strippings 2 and 3, or in total strippings.

### DISCUSSION

Exposure to UVR may induce dramatic alternations in skin barrier function (30–32). The prime mechanism of UVR-induced damage to cutaneous tissues is thought to be the peroxidation of lipids (3). A single dose of UVR depleted human SC vitamin E by almost 50% and murine SC vitamin E by 85% (33). However, application of topical antioxidants may diminish or minimize such UVR-caused deleterious effects on skin (4–11).

Vitamin E (tocopheryl acetate) is a lipophilic endogenous antioxidant that provides protection against UV-induced

oxidative membrane damage. It is believed that the broad biological activities of vitamin E are due to its ability to inhibit lipid peroxidation and stabilize biological membranes (4,10,11). Vitamin E is a popular component as antioxidant in many skin care products to decrease or reverse photoaging and photo-damage and this effect has been documented (2,4,5,11,34,35). Obviously, the antioxidant capacity of any compound depends on different mechanisms of action, which take place in each case. These mechanisms are influenced by structural factors such as water solubility and partition coefficient (36), but the role of which part in this study has not been determined.

Healthy human skin has a slightly acid pH and the acidity of the skin maintains antimicrobial activity (37,38). Skin diseases might result if this natural acidic mantle has been disturbed. Particular attention should be paid to this issue when developing skin care products. The current study tested an emulsion containing two important features: vitamin E and a slightly acidic formulation pH balanced at 5.5. Previously, we demonstrated that this emulsion has superior antioxidant effect over its vehicle control in vitro (13). Interestingly, current study showed that both of vitamin E emulsion and its vehicle control proved effective in preventing the induction of erythema and reduced inflammatory by the UV exposure; that is, the vehicle control showed partial benefits against UVR. Vehicles are well known to influence the hydration of the SC and may have some “therapeutic” effects (39). The authors speculate that the vehicle control might have some ability for sunscreens. However, the effect of vitamin E emulsion exceeded the activity of the vehicle control.

Analyzing antioxidant capacity did not show statistical difference except in the first SC stripping. It might be due to the UVR being too aggressive and even in the short period of less than three minutes it depleted the endogenous and exogenous vitamin E in the superficial SC layers. Further experiment is suggested to take stripping into the deeper SC layer to explore the time point of UVR exposure affecting depth in SC. Additionally, to decrease UVR exposure—for example, below MED level—is also an interesting study.

## REFERENCES

- Thiele JJ, Dreher F, Maibach HI, et al. Impact of ultraviolet radiation and ozone on the transepidermal water loss as a function of skin temperature in hairless mice. *Skin Pharmacol Appl Skin Physiol* 2003; 16:283–290.
- Thiele JJ, Dreher F, Packer L. Antioxidant defense systems in skin. In: Elsner P, Maibach HI, eds. *Cosmeceuticals, Drugs Vs. Cosmetics*. New York: Marcel Dekker, 2000:145–187.
- Thiele JJ. Oxidative targets in the stratum corneum. A new basis for antioxidative strategies. *Skin Pharmacol Appl Skin Physiol* 2001; 14(suppl 1):87–91.
- Steenvoorden DP, van Henegouwen GM. The use of endogenous antioxidants to improve photoprotection. *J Photochem Photobiol B Biol* 1997; 41:1–10.
- Dreher F, Maibach HI. Protective effects of topical antioxidants in humans. In: Thiele JJ, Elsner P, eds. *Oxidants and Antioxidants in Cutaneous Biology*. Basel: Karger, 2001:157–164.
- Steenvoorden DP, Beijersbergen van Henegouwen G. Protection against UV-induced systemic immunosuppression in mice by a single topical application of the antioxidant vitamins C and E. *Int J Radiat Biol* 1999; 75:747–755.
- Stab F, Wolber R, Blatt T, et al. Topically applied antioxidants in skin protection. *Methods Enzymol* 2000; 319:465–478.
- Kohen R. Skin antioxidants: their role in aging and in oxidative stress—new approaches for their evaluation. *Biomed Pharmacother* 1999; 53:181–192.
- Kullavanijaya P, Lim HW. Photoprotection. *J Am Acad Dermatol* 2005; 52:937–958.
- Eberlein-Konig B, Placzek M, Przybilla B. Protective effect against sunburn of combined systemic ascorbic acid (vitamin C) and d-alpha-tocopherol (vitamin E). *J Am Acad Dermatol* 1998; 38:45–48.
- Dreher F, Gabard B, Schwindt DA, et al. Topical melatonin in combination with vitamins E and C protects skin from ultraviolet-induced erythema: a human study in vivo. *Br J Dermatol* 1998; 139:332–339.
- Packer L, Valacchi G. Antioxidants and the response of skin to oxidative stress: vitamin E as a key indicator. *Skin Pharmacol Appl Skin Physiol* 2002; 15:282–290.
- Zhai H, Choi MJ, Arens-Corell M, et al. A rapid, accurate, and facile method to quantify the antioxidative capacity of topical formulations. *Skin Res Technol* 2003; 9:254–256.
- Zhai H, Behnam S, Villarama CD, et al. Evaluation of the antioxidant capacity and preventive effects of a topical emulsion and its vehicle control on the skin response to UV exposure. *Skin Pharmacol Appl Skin Physiol* 2005; 18:288–293.
- Zhai H, Cordoba-Diaz M, Wa C, et al. Determination of the antioxidative capacity of an antioxidant complex and idebenone: an in vitro rapid and sensitive method. *J Cosmet Dermatol* 2008; 7:96–100.
- Do A, Koo J. Initiating narrow-band UVB for the treatment of Psoriasis: table 4, how to do MED skin testing. *Psoriasis Forum* 2004; 10:7–11.
- Wilhelm KP, Surber C, Maibach HI. Quantification of sodium lauryl sulphate dermatitis in man: comparison of four techniques: skin color reflectance, transepidermal water loss, laser Doppler flow measurement and visual scores. *Arch Dermatol Res* 1989; 281:293–295.
- Pinnagoda J, Tupker RA, Agner T, et al. Guidelines for trans-epidermal water loss (TEWL) measurement. *Contact Dermatitis* 1990; 22:164–178.
- Elsner P, Berardesca E, Maibach HI. *Bioengineering of the Skin: Water and the Stratum Corneum*. Boca Raton: CRC Press, 1994.
- Bircher A, De Boer EM, Agner T, et al. Guidelines for measurement of cutaneous blood flow by laser Doppler flowmetry. *Contact Dermatitis* 1994; 30:65–72.
- Berardesca E, Elsner P, Maibach HI. *Bioengineering of the Skin: Cutaneous Blood Flow and Erythema*. Boca Raton: CRC Press, 1995.
- Wilhelm KP, Maibach HI. Skin color reflectance measurement for objective quantification of erythema in human beings. *J Am Acad Dermatol* 1989; 21:1306–1308.
- Fullerton A, Fischer T, Lahti A, et al. Guidelines for measurement of skin colour and erythema. *Contact Dermatitis* 1996; 35:1–10.
- Tagami H, Ohi M, Iwatsuki K, et al. Evaluation of the skin surface hydration in vivo by electrical measurement. *J Invest Dermatol* 1980; 75:500–507.
- Triebkorn A, Gloor M. Noninvasive methods for the determination of skin hydration. In: Frosch PJ, Kligman AM, eds. *Non-invasive Methods for the Quantification of Skin Functions*. Berlin: Springer-Verlag, 1993:42–55.
- Popov IN, Lewin G. Photochemiluminescent detection of antiradical activity. IV: testing of lipid-soluble antioxidants. *J Biochem Biophys Methods* 1996; 11:1–8.
- Popov IN, Lewin G. Photochemiluminescent detection of antiradical activity: II. Testing of nonenzymic water-soluble antioxidants. *Free Radic Biol Med* 1994; 17:267–271.
- Lewin G, Popov I. Photochemiluminescent detection of antiradical activity. III: a simple assay of ascorbate in blood plasma. *J Biochem Biophys Methods* 1994; 28:277–282.
- Popov I, Lewin G. Antioxidative homeostasis: characterization by means of chemiluminescent technique. *Methods Enzymol* 1999; 300:437–456.
- Holleran WM, Uchida Y, Halkier-Sorensen L, et al. Structural and biochemical basis for the UVB-induced alterations in epidermal barrier function. *Photodermatol Photoimmunol Photomed* 1997; 13:117–128.
- Haratake A, Uchida Y, Schmutz M, et al. UVB-induced alterations in permeability barrier function: roles for epidermal hyperproliferation and thymocyte-mediated response. *J Invest Dermatol* 1997; 108:769–775.
- Haratake A, Uchida Y, Mimura K, et al. Intrinsically aged epidermis displays diminished UVB-induced alterations in barrier function associated with decreased proliferation. *J Invest Dermatol* 1997; 108:319–323.
- Thiele JJ, Traber MG, Packer L. Depletion of human stratum corneum vitamin E: an early and sensitive in vivo marker of UV induced photo-oxidation. *J Invest Dermatol* 1998; 110:756–761.
- Fuchs J. Potentials and limitations of the natural antioxidants RRR-alpha-tocopherol, L-ascorbic acid and beta-carotene in cutaneous photoprotection. *Free Radic Biol Med* 1998; 25:848–873.
- Darr D, Dunston S, Faust H, et al. Effectiveness of antioxidants (vitamin C and E) with and without sunscreens as topical photoprotectants. *Acta Dermatol Venereol* 1996; 76:264–268.
- Perugini P, Vettor M, Rona C, et al. Efficacy of oleuropein against UVB irradiation: preliminary evaluation. *Int J Cosmet Sci* 2008; 30:113–120.
- Chikakane K, Takahashi H. Measurement of skin pH and its significance in cutaneous diseases. *Clin Dermatol* 1995; 13:299–306.
- Rippke F, Schreiner V, Schwanitz HJ. The acidic milieu of the horny layer: new findings on the physiology and pathophysiology of skin pH. *Am J Clin Dermatol* 2002; 3:261–272.
- Fluhr JW, Rigano L. Clinical effects of cosmetic vehicles on skin. *J Cosmet Sci* 2004; 55:189–205.

# Treatment and noninvasive clinical assessment of androgenetic alopecia

R. Scott Youngquist, Jeanette A. Richards, Caroline W. Cardin, and Thomas L. Dawson, Jr.

## INTRODUCTION

As hair production is one of the most metabolically demanding processes in the human body, hair loss can result from a multitude of factors, both extrinsic and intrinsic. This chapter focuses on hair loss associated with hormonal influence, androgenic and chronogenetic (or senile) alopecia. There is now evidence that changes in hormonal status can affect both men (androgenetic) and women [associated specifically with menopause and also from hormonal changes associated more loosely with aging (female pattern hair loss, or FPHL)]. These hormone-related alopecias are the most common alopecias in men and women, with a reported prevalence of approximately 50% in Caucasians (1–5), and a much lower prevalence in Asians (2,6), Native Americans, and African-Americans (4). There is a clear genetic linkage, with evidence for polymorphism in the androgen receptor as a contributing factor, although it is also clearly impacted by multiple factors, both genetic and epigenetic.

Male androgenetic alopecia results from androgen-dependent miniaturization of the scalp hair follicles, with dihydrotestosterone (DHT) implicated as the primary agent (7–9). The loss of hair is associated with a distinct shortening of the hair cycle, that is, an increased number of growing anagen hairs entering the resting or telogen phase earlier than normal. This results in hairs falling out prematurely. In each subsequent cycle the anagen phase is shortened, which results in the hair shaft becoming shorter, thinner, and less pigmented. In addition, the lag phase (the interval between the shedding of telogen hair and the emergence of replacement anagen hairs, also referred to as exogen) becomes longer. Terminal hair is thus transformed into intermediate and finally miniaturized hair. This transformation can occur in as few as one to two cycles (10). Male pattern hair loss begins in two general progressions, either a gradual receding of the frontal hairline or a loss of hair density in the vertex (3,11). In males, androgen-mediated hair loss can advance to the complete absence of visible hair except on the sides and posterior of the scalp.

In women, FPHL has also been linked to androgens in genetically susceptible populations, but that linkage is far less clear than in males (12). However, estrogen levels clearly play a role in FPHL as the onset of menopause results in a significant reduction in frontal hair density and diameter (13). Like men, thinning begins between ages 12 and 40 years and the inheritance pattern is polygenetic, although the pattern of hair loss is different in men and women with women presenting diffuse hair loss over the top of the scalp and no recession of the vertex or frontal hairline (14). Because of the diffuse nature of FPHL, women's initial complaint is most frequently a widening of the part line. In FPHL, hair density declines with age, but recent work has shown that hair diameter also decreases with age and

that hair diameter may be of comparable importance to hair density for women's overall satisfaction with their hair (see sect. "Hair Diameter") (15,16).

## EFFECTIVE THERAPIES

Minoxidil (Rogaine<sup>®</sup>) and finasteride (Propecia<sup>®</sup>) are the only two active ingredients approved by the U.S. Food and Drug Administration (FDA) for androgenetic alopecia (AGA). Minoxidil is available in over-the-counter topical products (2% and 5% for men, 2% for women) (17–40). Finasteride is an oral prescription medication (1 mg/day) (18,19,22,30,38,41–60). Both minoxidil and finasteride have been approved for the treatment of androgenetic alopecia in men, while only 2% topical minoxidil is recommended for the treatment of androgenetic alopecia in women (43,48–50). Oral finasteride was found to be ineffective in the treatment of androgenetic alopecia in postmenopausal women (46).

### Minoxidil

Minoxidil (2,4-diamino-6-piperidion-pyrimidine-3-oxide) is a potent antihypertensive agent that was found to induce hypertrichosis in about 70% of patients within two months of initiation of therapy. Topically at 1% to 5% (18,21,27), minoxidil has been demonstrated to induce hair regrowth in men with androgenetic alopecia. As a potent antihypertensive drug, minoxidil was thought to act as a direct peripheral vasodilator and potassium channel opener to enhance cutaneous blood flow to the scalp. The mode of action of minoxidil in hair regrowth has not been completely determined, but researchers have proposed that minoxidil works as a sulfonyleurea receptor (SUR) activator and prolongs the anagen phase of hair follicles in the following manner: (i) inducing cell growth factors such as vascular endothelial growth factor (VEGF), hepatocyte growth factor (HGF), insulin-like growth factor 1 (IGF-1), (ii) potentiating HGF and IGF-1 actions by the activation of uncoupled SUR on the plasma membrane of dermal papilla cells, (iii) inhibiting TGF- $\beta$  from inducing apoptosis of the hair matrix cells, (iv) dilating hair follicle arteries, and (v) increasing blood flow in dermal papillae (56). Despite significant research over the last four decades, the specific mechanism(s) of minoxidil action on hair regrowth remains unclear and hotly debated.

Numerous clinical studies have demonstrated the efficacy and safety of topical hair regrowth products containing either 2% or 5% minoxidil in men and women with androgenetic alopecia (18,21,23–29,31–37,39,40,61,62). Literature reports indicate that treatment with minoxidil at 1% to 5% leads to increased hair counts (18,20,23–29,31–36,39,40). Other clinical endpoints that have been studied include patient and investigator

evaluation of hair regrowth (21,24–26,28,29,31–34,36,37,39,40,61), hair weight (18,21,43), diameter of the bald area (26), and global pictures (20,21,23–27,29,31–34,36,37,39,40,48–50). These end-points correlated with the hair count, further demonstrating the efficacy of minoxidil. The study lengths ranged from six months to five years in 18- to 50-year-old men and women with androgenetic alopecia. In addition, imaging methods with increased sensitivity for detecting hair regrowth were developed (21,23,32,40). Improvement in methods with computational automation has reduced the tedious manual hair counting process and shortened the time for detecting hair regrowth changes from years to months. An alternative form of topical 5% minoxidil has recently been developed to improve application to balding areas. It is a propylene glycol-free foam and has demonstrated efficacy and safety in the treatment of hair loss in men suffering from AGA (63).

### Finasteride

Finasteride (Propecia) is the first oral pharmacologic therapy approved for the treatment of men with androgenetic alopecia. Originally developed for the treatment of men with benign prostatic hyperplasia (BPH) at a dose of 5 mg/day, it has a well-established, excellent safety profile and is now approved for AGA treatment in men at a dose of 1 mg/day. Clinical dose-ranging studies demonstrated that 1 mg is the optimal dose and has similar efficacy to 5 mg for reducing hair loss progression and restoring scalp hair growth in men aged 18 to 60 years (18–20,22,30,38,41,42,44–47,51–54,59,60). Improvements observed with finasteride treatment include increases in hair counts, thickness, length, growth rate, growth duration, and pigmentation. More recent studies suggest that finasteride treatment may activate terminal hair follicles for faster regrowth and longer anagen phases (64).

Androgenetic alopecia in men is associated with an inherited sensitivity to the effects of androgens, primarily DHT, on scalp hair. DHT is produced by the steroid enzyme 5 $\alpha$ -reductase, which converts testosterone to DHT. Oral finasteride is a type II selective 5 $\alpha$ -reductase inhibitor and lowers serum, prostate, and scalp DHT levels. Investigations into the molecular mode of action of finasteride suggest that DHT may be signaling a greater expression of caspase, which plays an important role in signaling programmed cell death, thereby affecting the hair growth cycle. Finasteride appears to influence caspase and X chromosome-linked inhibitor of apoptosis (XIAP) expression in the hair follicles cells, thus signaling anagen and active growth in the hair cycle (58,65). In addition, finasteride mediates upregulation of IGF-I, a molecular hair growth regulator in the dermal papilla, which may contribute to clinical improvement (66).

### EMERGING THERAPIES

Advances in the understanding of the hair follicle and the hair growth cycle have led to several innovative approaches that represent potential future therapies for treatment of AGA. Devices that deliver light energy such as the HairMax Laser-Comb have demonstrated efficacy and safety in promoting hair growth in males (67). Treatment options, particularly for women who were previously limited to minoxidil and select off-label antiandrogens such as spironolactone and cyproterone acetate, are expanding to combination therapies with follicular unit extraction and other hair restoration methods. Insights into biological mechanisms of hair growth have also been gained

from experimental molecules such as prostaglandins, ketoconazole, and pyrithione zinc. Ketoconazole and pyrithione zinc have antimicrobial activity and are effective in improving androgenic alopecia (40,68). This implicates scalp microflora such as *Malassezia* spp. in the hair loss process and also opens new avenues for the use of antimicrobials in prevention of hair loss. Emerging therapies that have demonstrated some efficacy also include caffeine (69,70) and adjunct therapies with minoxidil such as tretinoin that may circumvent twice-daily minoxidil dosage (71).

### Prostaglandins

Analogues of prostaglandin F<sub>2</sub> alpha (PGF<sub>2 $\alpha$</sub> ) are potential future therapies for hair regrowth. Drugs such as latanoprost (Xalatan<sup>®</sup>), travoprost (Travatan<sup>®</sup>), and bimatoprost (Lumigan<sup>®</sup>), which are glaucoma treatments, have the unusual side effects of increasing hair growth, thickness, and pigmentation in the eyelashes of patients receiving an ophthalmic dose (72–75). These hair growth effects were first noted with latanoprost and have been attributed to activating and prolonging the anagen phase of the hair growth cycle (76). The exact molecular mechanism of PGF<sub>2 $\alpha$</sub>  analogues in hair regrowth is still unknown; however, it is reasonable to expect that part of the signaling cascade occurs via the female pattern (FP) prostanoid receptors and downstream protein kinase C pathways. PGF<sub>2 $\alpha$</sub>  analogues are reportedly efficacious in reversing instances of alopecia areata of the eyelashes (77–79). Recently, a 0.03% topical bimatoprost solution (Latisse<sup>®</sup>) was developed as the first and only FDA-approved drug for improving eyelash length, thickness, and darkness in patients with hypotrichosis. Significant differences in hair growth properties exist between eyelashes and scalp hair, particularly because scalp hair has a much higher percentage of hairs in anagen (90–95% in scalp, versus less than 30% in eyelash) (77). It therefore remains to be determined whether topical application of prostaglandins will be a viable treatment option for scalp hair regrowth in men or women.

### Hair Restoration

The field of hair restoration therapy has evolved over the past several years to include methods that are less invasive and allow less visible scarring and enhanced reconstitution of challenging areas like sideburns and eyebrows (80). Of note is the follicular unit extraction method that removes just the critical follicular structures required to obtain quality grafts, a significant improvement for obtaining aesthetic hair replacements (81–83). Another emerging method is hair follicle reconstitution that requires the harvest of dermal cells from patients. These cells are cultured and expanded in vitro and then injected into the scalp to form new hairs (84–87). The possibility of using hair follicle cells for engineering new hairs may become a realistic alternative for hair loss treatment once larger controlled studies that demonstrate efficacy and tolerability are completed.

### EFFICACY MEASURES OF HAIR REGROWTH IN HUMANS Density

#### Overview

A key weakness in hair biology research remains the inability to reliably and predicatively measure the effect of aging, hormone changes, or treatment on hair quantity and quality. Most methods require sampling from a small site, from 1 to 5 cm<sup>2</sup>, then extrapolating this measure to the entire scalp. This

extrapolation can lead to significant error, as hairs across the scalp are known to be under differential control (13). A further complication is the nonrandom and highly irregular pattern of scalp hairs. This patterning makes repositioning at sample sites crucially important, and requires the placement of a tattoo on the site for any consistent analyses (40). There are methods utilizing global photography. However they suffer from the variability resulting from hair styling, color, and humidity, among other factors. Here we have reviewed some of the most common methods to measure changes in hair density and diameter, focused on detecting responses to treatment of hair loss from any cause.

#### *Direct Manual Hair Count*

Early hair growth studies began in the 1980s and used the direct hair count method (18,24,27–29,31,33,34,36,43,88). Efficacy was determined by counting vellus, intermediate, and terminal (non-vellus) hairs in an area of 1-in. diameter (5.1 cm<sup>2</sup>) in the midvertex. Briefly, a target area was clipped to a uniform length of 2 to 3 mm. A magnifying lens with side lighting was used and visible hairs were manually counted. Significant bias was present based on the individual counting, so it was necessary to have the same person count all subjects. A reference site at the center of the 1-in. diameter circle was marked by either tattoo or punch biopsy. This methodology was labor intensive and prone to systematic bias by missing small or minimally pigmented hairs. The primary benefit was that the hairs that would be the most noticeable by the subjects were the ones most reliably quantified.

#### *Macrophotographic Manual Hair Count*

In the 1990s, the manual hair counting method was updated by counting dot maps representing hairs present in enlarged color macro photographs (19,21,22,30,32,35,38,41,42,44,45, 51–54,60,89). This technique involved identification of a 1-in. diameter circular area (5.1 cm<sup>2</sup>) at the anterior leading edge of the vertex thinning area and clipping all hairs within the area to 1 mm. The area to be photographed was targeted with a dot tattoo to maximize reproducibility and prevent “drift” of the target area over time. Photographs had to be taken with a dedicated, preset camera system to maintain reproducibility. The photographs were then enlarged to 8 × 10 in. color transparencies and converted to dot maps of visible hairs by trained technologists. This method revealed more of the small or non-pigmented hairs, and was a step forward in precision. However, it was reliant on labor intensive human counting and subject to bias from the individual counter. Also, exact repositioning remained very difficult, increasing the signal-to-noise ratio and adding variability to data analysis.

#### *Fiberoptic Microscopic Hair Count Method—Phototrichograms*

*Phototrichograms.* While macro photographs improved hair count methodology it was still cumbersome, requiring photography, film processing, and dot map creation with manual or computer-assisted hair counting. Hence, with the continual improvement of digital image acquisition and computational analysis systems, more sensitive, precise, and time-saving methods have been developed using fully or semi-automated systems (40,90–92).

At the initial visit, imaging sites are tattooed for subsequent repositioning and hair is clipped to 0.8 mm. Prior to imaging, a drop of water is placed on each imaging site to minimize light scattering due to scalp flakes or texture. This is

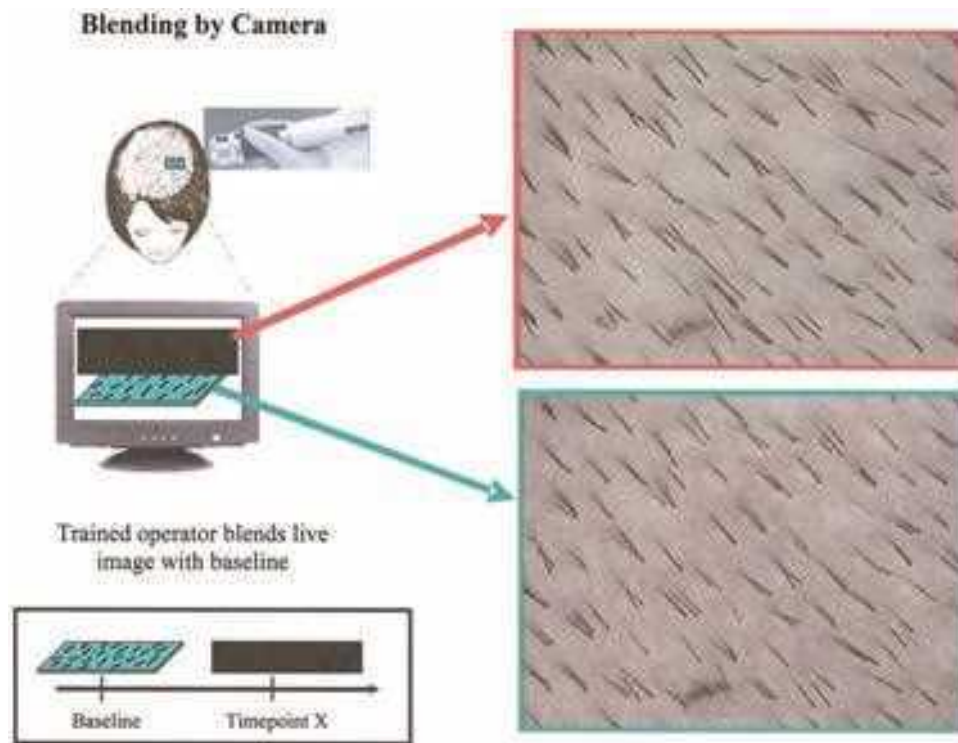
essential to enable automated or computer-assisted counting of sharp edges of flakes and scalp topography by the software. The drop of water does, however, minimize the appearance of nonpigmented hairs. This has the disadvantage of underestimating the number of miniaturized, vellus, or gray hairs, with the advantage that it biases the result to the pigmented, terminal hair that are most likely to be noticeable by the subject. A HI-Scope<sup>®</sup> fiberoptic microscope and imaging unit (Moritex USA, Inc, California, U.S.) with a 25× contact lens and a dome cap are used to achieve proper magnification and uniform lighting. Images are captured and digitized via a computer system with TGi Ultra II frame grabber and analyzed via the Optimas 6.2 image analysis software (40).

At each posttreatment visit, the probe is repositioned to achieve alignment with a partially transparent baseline image. Using the tattoo as a guide, the fiberoptic head is moved to align the hair follicle openings and hairs in a process called real-time blending. This method results in a near-perfect repositioning of the pretreatment images with the subsequent posttreatment images (Fig. 58.1). As with the macro photographic method, anagen hair counts can be determined by counting hairs that lengthened in scalp images taken 24 hours later. Image analysis algorithms can also be employed to measure hair diameter. Increased sensitivity from this fiberoptic microscopic method shortened the time for detecting statistically significant differences between treatments.

*TrichoScan<sup>®</sup>.* TrichoScan<sup>®</sup> is a computerized phototrichogram tool to automatically analyze macro or fiberoptic scalp images (93–95). It is purported to have the ability to analyze multiple biologic parameters of hair growth including density, diameter (pixels converted to microns via calibration images), growth rate (millimeters per day), and anagen/telogen ratio. This method combines epiluminescence microscopy (ELM) with automatic digital image analysis. Briefly, the site is identified and clipped as for other macro photography. The center of the area is marked with a tattoo to assist repositioning. The shaved short hair is dyed black to increase the hair-scalp contrast prior to imaging. For the hair number and thickness determinations, the hairs are colored immediately after clipping. For hair growth rate and anagen/telogen determinations the hairs are colored three days after clipping.

Software developed to analyze the digital images determines hair density, diameter, growth rate, and anagen/telogen ratio. Algorithms are utilized to select color components, reject artifacts (bubbles and reflections), determine the threshold, define the hair regions, eliminate the tattoo spot, and analyze the hair from each region. This method is routinely used in clinical studies for assessing hair growth-promoting substances, as well as to study the different forms of diffuse hair loss in various hair-related disorders (93,95,96).

TrichoScan has been used extensively to more fully understand hair biology parameters. Its development has improved the speed of analysis to the point where multiple images can be analyzed much more quickly than was previously possible, enabling the use of more subjects and assisting in better, more powerful clinical designs. However, as with any new method, the precision and accuracy of the TrichoScan system remains controversial. Van Neste and Trüeb conducted a study where TrichoScan was compared to the more labor intensive manual counting, and found that there were significant differences between the “gold standard” of manual counting and the computer-assisted analyses (97). Further work will be necessary to fully understand the positive and negative



**Figure 58.1** Blending by camera manipulation. *Source:* From Ref. 13.

aspects of automated analysis methods. Also, as technology improves, so will automated methods.

#### *Unit Area Trichogram*

Another highly accurate but labor intensive measurement of hair density and growth parameters is the "unit area trichogram." In this method, a 1 cm<sup>2</sup> area is identified and clipped to 2 mm. Every hair in the site is plucked, and the hair cycle stage was identified by microscopic evaluation of the hair bulb (98). The unit area trichogram is highly accurate but again very labor intensive and hence unsuitable for large-scale clinical trials. Hair variables were evaluated in 12 Caucasian subjects employing both unit area and phototrichograms methods. The mean value for total hair density was significantly underestimated by the phototrichogram (181 vs. 237 hairs/cm<sup>2</sup>); however, no significant difference was found between this phototrichogram value and the number of nonvellus hairs/cm<sup>2</sup>. Estimates for the percentage of anagen hairs were similar with both methods. Hair diameters from this early phototrichogram were too unreliable to be of any practical use. It will remain to be investigated how unit area trichograms analysis compares to more modern and more accurate phototrichograms.

#### **Hair Diameter**

The perception of hair mass or volume is a function of both density and diameter (99), but careful consideration reveals that changes in hair diameter could be as or more influential than changes in hair density. For example, an 80- $\mu$ m hair has almost twice the mass or volume of a 60- $\mu$ m hair because it has approximately double the cross-sectional area. Therefore, in

two samples with the same number of hairs, the one with 80- $\mu$ m shafts has almost twice as much hair mass or volume as the one with 60- $\mu$ m shafts. To put this in context, a 10% drop in density will result in a 10% change in hair mass or volume, while a 10% change in diameter will result in a 20% change in hair mass or twice the density effect.

Hair diameter can be obtained from multiple methods, including linear density (100), phototrichogram (90,92), laser fiber analysis (Diastron<sup>®</sup>), and optical fiber diameter analysis (OFDA) (101). As human hair is variable in diameter even across a single fiber, methods have been developed that assess either single points along the fiber or averages for the entire fiber. Further, the shape, or cross-sectional area, can be highly variable and account for multiple hair "feel" parameters. All of these factors must be considered when choosing an optimal method.

#### *Linear Density*

The linear density diameter is a calculation based on the number of fibers in a sample, the length of the sampled fibers, and an average density of human hair (100). This method provides an accurate average diameter for a sample, but does not take into account the variations in diameter along fibers or variations in shape of the fiber.

#### *Phototrichogram*

Current high-resolution phototrichogram techniques can be used to measure hair diameter (40). This method requires software that can enumerate the fibers and count the total area covered by hair. These numbers are then used to calculate the average diameter of each hair in a sample. This method is



limited to average diameters as the resolution of current camera technology limits the size of a pixel in an image to approximately 10  $\mu\text{m}$ . This means that many hairs need to be averaged to report accurate and meaningful results. This method also measures the hair approximately 1 mm from the scalp and so can be useful for measuring the effect of treatments, as newly grown hair is all that is contained in that short fragment. As the hair is attached to the scalp and held in place by the follicle, no shape diversity can be captured.

#### *Diastron*<sup>®</sup>

The most common method in use today to calculate hair diameter is the laser method developed and employed by the Diastron device. Description of the full utility of this method is beyond the scope of this review, but ample information can be found on the Diastron company website. Briefly, single hair fibers are mounted in a holder device and rotated while in the beam of a laser. The diameter of the hair shaft is then calculated by the bounce from the fiber. This method is highly accurate and precise, and can provide detailed information on single fibers. In addition to average diameter, this method provides a measure of the fiber shape termed ellipticity and can be applied to multiple sites along the fiber. The potential issue is the relatively low throughput compared with the diversity of human scalp hair. It also requires 4 in. of hair sample and about eight months of growth. This requires an extended clinical trial to apply the method to hairs produced during the study.

#### *OFDA*

Optical fiber diameter assessment allows for the measurement of many hundreds to thousands of fibers per sample (13,101,102). Briefly, 2-mm snippets are cut from the end of a clinical sample, washed, equilibrated, and cast onto glass slides. The slides are read by a computerized optical laser that finds the 2-mm axis and measures the perpendicular. As this technique allows for the measurement of so many fibers per sample, it is valuable for understanding the effects of treatment across larger scalp sites and the effect on the distribution of hair diameters. As it also measures only short segments of the fiber, it can be used to evaluate the effect of treatment periods of less than one month. Recently OFDA was used to measure differences in hair diameter in pre- and postmenopausal women, demonstrating the utility in human clinical studies. The limit of this method is that variability is not determined along the fiber shaft, and no information is gleaned about fiber shape or ellipticity. The primary advantages are throughput and breadth of analysis (13).

### **Combination Measures**

As hair quantity is determined by the hair's density ( $n/\text{cm}^2$ ) and diameter ( $\mu\text{m}$ ), hair loss and hair growth result from changes in either or both. Therefore an ideal hair-measuring technology would measure the influence of both density and diameter (99).

#### *Cross-Section Trichometer*

A new device has recently entered the field of hair loss measurement, the cross-sectional trichometer. This measure utilizes an instrument that captures hairs from a predetermined area and compresses them into a steady and precisely determined area caliper. Care must be taken for accurate sample selection,

as small changes in the number of fibers captured have a strong influence on the measurement. Careful control of the selected site is accomplished with a  $2 \times 2 \text{ cm}^2$  dye marker. All of the hairs inside the demarked  $4 \text{ cm}^2$  area are captured into the device, providing highly reproducible results. Future work with this device could provide a noninvasive, fast, and accurate measure of hair "mass" or "volume," which would be predicted to be highly relevant to the perceived efficacy in hair loss treatment (99).

#### *Hair Weight*

Hair weight and hair number have been demonstrated to be valid parameters for assessing the efficacy of both minoxidil (18,43) and finasteride. In this method, a representative site is selected on the thinning frontal/parietal scalp. A template consisting of a plastic sheet with a  $1.2 \text{ cm}^2$  hole is placed over the selected site. All hairs within the template are pulled through with the help of a magnification lamp. The hairs are hand clipped to 1 mm in length with surgical scissors. The four corners of the square are then permanently marked with ink. In subsequent posttreatment visits, the template is placed on the marked corners and the procedure repeated. All the hairs from each collection are laid out on a grid and counted. Hairs with pointed versus blunt tips are separated for the counting procedure. The hair is placed in a chamber of an analytical balance and weighed.

In addition to hair weight and hair count, hair width and length could be assessed. A subsample of 50 hairs is selected using a computer-generated randomization. The hair is separated for measurement of width and length. Hairs are mounted on slides under plastic wrap and a wide-field projection microscope is used with different lenses for width and length measurements. Hair length is estimated by tracking the projected length of a hair on the screen with a map distance, and diameter is estimated by inspection of the projected image with a calibrated reticle. This methodology remains highly labor intensive.

### **Global Assessment**

#### *Global Macro Photos*

While precise technical measures of hair growth are important for evaluation of pharmacologic intervention, it is also important to understand whether technically measurable improvements lead to changes that can be perceived by the patient and investigator. These evaluations are based on global or whole-head macro photography and rating of performance using perceptual scales by the patients and investigators. Although extremely important, these types of assessments are also extremely difficult due to the numerous and aforementioned complicating factors. The investigator must be conscious of and tightly control humidity, hair style, hair color, background and clothing colors, lighting, camera type, and magnification, among others. It is also very important to observe these features in presentations of hair benefit claims and data as manipulation of any of these facets can lead to inaccurate interpretation.

#### *Subject's Self-Perception*

Patient assessment is measured by administration of a validated questionnaire based on seven parameters: four on efficacy and three on satisfaction with their appearance. These parameters include appearance of the bald spot and the hair, hair growth, effectiveness of therapy in slowing hair loss, and

satisfaction with the hair appearance and the frontline (22). Patients may also evaluate their condition after reviewing randomized color pre- and posttreatment photographs of the vertex (40). It is not uncommon for self-perception to lag far behind technical assessment. This is due to multiple factors, including the amount of time required for new hairs to grow to a length appreciated by the subject and the location of the balding site on the vertex, which is not easily visible to the subject. For instance, technical effects of minoxidil can be measured as early as 8 to 12 weeks, but self-perception of effects can require 9 to 12 months.

#### *Expert Assessment*

Investigators assessed the scalp of patients after treatment using a standardized seven-point change rating scale of hair growth (−3 to +3) after referring to a baseline global photograph of the vertex scalp of the patient as a reference for the pretreatment condition (22). Generally, investigator assessment time to noticeability falls between technical assessment and subject assessment. Product efficacy can also be evaluated by an expert panel. In this method, standardized color global photographs of the vertex scalp have also been taken with the head in a stereotactic positioning device and then visually graded by trained, calibrated experts. Paired baseline to post-treatment slides are then independently and blindly reviewed by an expert panel of dermatologists using a seven-point change rating scale of hair growth (−3 to +3) of the vertex and frontal views (22,40). Expert graders will have much higher sensitivity than subject assessments and usually are able to identify effects sooner. However, the perception of the individual under treatment must remain the ideal, and be the focus of development of new therapies.

## DISCUSSION

Although the methods described are all appropriate techniques for assessing the efficacy of hair growth compounds in humans, no single method addresses all questions relating to the study of the efficacy and mode of action of hair loss treatment agents. Therefore, one must consider the primary objective of the investigation and utilize the appropriate array of techniques to address the clinical question posed and to collect the relevant measures to assess the outcome.

Improvements in optics, computer hardware and software for capturing, repositioning, storing and recalling images have improved the evaluation of new treatments, increasing sensitivity and speed. Hair count measurement techniques have progressed from manual counts of hairs on the scalp to macrophotography to fiberoptic microphotography. Recent developments using automated methods have increased the capability and sensitivity to monitor hair loss and treatment responses, including hair density, hair diameter, hair growth rate, and anagen/telogen ratio (57).

Because of the increased sensitivity for detecting different hair regrowth parameters, along with the ease of capturing images in a clinical setting, noninvasive image analysis techniques have improved our ability to track pre- and post-treatment hair density changes and cumulative hair thickness in as little as four weeks (30,40,93). In addition, the increased sensitivity derived with these techniques has enabled a reduction in the number of subjects required to detect the same magnitude differences between active and placebo treatments with as few as 30 subjects (13). Other endpoints, such as hairs in anagen (hairs

that grew in length over time), hair diameter, hair growth rate, and anagen/telogen ratios, can be determined from this imaging data. Computer software and algorithms have increased the accuracy and speed of measurements, giving these methods the capacity necessary for analysis of data from large clinical trials.

While screening studies can be shortened to 4 to 12 weeks with new improved analysis methods, these techniques do not negate the need to establish the long-term and consistent performance of hair loss treatment substances with studies of one to three years in duration, particularly for self-perception measures. The above new measurement techniques facilitate field execution and decrease the time, effort, and costs required in the conduct of large pivotal phase III trials to establish the efficacy and safety of hair regrowth active substances for FDA submission. On the contrary, these techniques do not replace exploratory methods targeted at understanding the mechanism of new hair regrowth products. Methods such as biopsies combined with imaging or molecular DNA/RNA or biochemical marker techniques are still needed to derive an understanding of how and why these compounds work.

For clinical design, the use of both active and placebo controls and having adequate subject numbers and diversity are critical for properly evaluating any alopecia therapy. For example, considerations in subject enrollment include ensuring that the population covers a range of hair loss progression (Norwood/Hamilton scale scores for men, Ludwig scale scores for women), but accounts for other critical variables such as age and ethnicity and controls for medical conditions and medications that can affect hair biology. The selection of the monitoring site is also critical for study outcome. For example, in women, the effect of FPHL is more pronounced on the frontal than on the occipital scalp, so studies with measurements from the frontal region will likely be more sensitive (13).

Since the above objective measurements do not necessarily translate immediately into patient-perceived benefits, subjective perception measures of hair growth by both patients and investigators are necessary in treatment evaluation, especially in pivotal long-term trials, to ensure that clinically meaningful benefits have been produced. This is key to the successful marketing of hair regrowth products.

This chapter has focused on describing the fundamental causes, appearance, treatments, and measurement of hair loss. We have addressed methods for tracking hair density and diameter as they are the variables most likely to be noticed by the subjects seeking treatment. Historically, treatment regimens have focused on scalp hair number density as the primary variable, as this was the perceived parameter most influenced by hair loss. However, recent research is indicating that characteristics beyond hair density play a crucial role in subjects' satisfaction with their hair. For example, hair diameter has been found to play a critical and highly influential role in both the perception of hair loss and in the efficacy of treatment (13,15,16,99). In another study, gray hair was found to be a more significant contributor to apparent age than hair thinning, and therefore addressing graying may be an important intervention for improving patient satisfaction (103). Given the importance of these hair characteristics, in the next few years new methods must be developed to measure these endpoints. A final consideration for addressing patient hair concerns is the strong linkage between scalp health and hair quality as demonstrated in studies with dandruff sufferers, and it is likely that measures of scalp health will begin to be used to link skin and hair biology (104).

## REFERENCES

- Bolduc C, Shapiro J. Management of androgenetic alopecia. *Am J Clin Dermatol* 2000; 1(3):151-158.
- Brodland DG, Müller SA. Androgenetic alopecia (common baldness). *Cutis* 1991; 47(3):173-176.
- Hamilton JB. Patterned loss of hair in man; types and incidence. *Ann N Y Acad Sci* 1951; 53(3):708-728.
- Hoffmann R, Happel R. Current understanding of androgenetic alopecia. Part II: clinical aspects and treatment. *Eur J Dermatol* 2000; 10(5):410-417.
- Tosti A, Camacho-Martinez F, Dawber R. Management of androgenetic alopecia. *J Eur Acad Dermatol Venereol* 1999; 12(3):205-214.
- Paik JH, Yoon JB, Sim WY, et al. The prevalence and types of androgenetic alopecia in Korean men and women. *Br J Dermatol* 2001; 145(1):95-99.
- Kaufman KD. Androgen metabolism as it affects hair growth in androgenetic alopecia. *Dermatol Clin* 1996; 14(4):697-711.
- Sawaya ME. Novel agents for the treatment of alopecia. *Semin Cutan Med Surg* 1998; 17(4):276-283.
- Kaufman KD. Androgens and alopecia. *Mol Cell Endocrinol* 2002; 198(1-2):89-95.
- Whiting DA. Possible mechanisms of miniaturization during androgenetic alopecia or pattern hair loss. *J Am Acad Dermatol* 2001; 45(3 suppl):S81-S86.
- Norwood OT. Male pattern baldness: classification and incidence. *South Med J* 1975; 68(11):1359-1365.
- Birch MP, Lashen H, Agarwal S, et al. Female pattern hair loss, sebum excretion and the end-organ response to androgens. *Br J Dermatol* 2006; 154(1):85-89.
- Mirmirani P, Luo F, Youngquist RS, et al. Hair growth parameters in pre- and post-menopausal women. In: Trüeb RM, Tobin DJ, eds. *Aging Hair*. Springer, 2010.
- Ludwig E. Classification of the types of androgenetic alopecia (common baldness) occurring in the female sex. *Br J Dermatol* 1977; 97(3):247-254.
- Tajima M, Hamada C, Arai T, et al. Characteristic features of Japanese women's hair with aging and with progressing hair loss. *J Dermatol Sci* 2007; 45(2):93-103.
- Birch MP, Messenger JF, Messenger AG. Hair density, hair diameter and the prevalence of female pattern hair loss. *Br J Dermatol* 2001; 144(2):297-304.
- Price VH. Treatment of hair loss. *N Engl J Med* 1999; 341(13):964-973.
- Price VH, Meneffee E, Strauss PC. Changes in hair weight and hair count in men with androgenetic alopecia, after application of 5% and 2% topical minoxidil, placebo, or no treatment. *J Am Acad Dermatol* 1999; 41(5 pt 1):717-721.
- Wolff H, Kunte C. [Therapy of androgenetic alopecia with finasteride. What must be considered in consultation and drug prescribing]. *MMW Fortschr Med* 1999; 141(37):38-40.
- Khandpur S, Suman M, Reddy BS. Comparative efficacy of various treatment regimens for androgenetic alopecia in men. *J Dermatol* 2002; 29(8):489-498.
- Olsen EA, Dunlap FE, Funicella T, et al. A randomized clinical trial of 5% topical minoxidil versus 2% topical minoxidil and placebo in the treatment of androgenetic alopecia in men. *J Am Acad Dermatol* 2002; 47(3):377-385.
- Kaufman KD, Olsen EA, Whiting D, et al. Finasteride in the treatment of men with androgenetic alopecia. Finasteride Male Pattern Hair Loss Study Group. *J Am Acad Dermatol* 1998; 39(4 pt 1):578-589.
- Olsen EA, Weiner MS, Amara IA, et al. Five-year follow-up of men with androgenetic alopecia treated with topical minoxidil. *J Am Acad Dermatol* 1990; 22(4):643-646.
- Rietschel RL, Duncan SH. Safety and efficacy of topical minoxidil in the management of androgenetic alopecia. *J Am Acad Dermatol* 1987; 16(3 pt 2):677-685.
- DeVillez RL. Topical minoxidil for androgenetic alopecia: optimizing the chance for success by appropriate patient selection. *Dermatologica* 1987; 175(suppl 2):50-53.
- Zauli D, Fusconi M, Tosti A, et al. Alopecia areata. *Arch Dermatol* 1985; 121(2):169.
- Vanderveen EE, Ellis CN, Kang S, et al. Topical minoxidil for hair regrowth. *J Am Acad Dermatol* 1984; 11(3):416-421.
- Shupack JL, Kassimir JJ, Thirumoorthy T, et al. Dose-response study of topical minoxidil in male pattern alopecia. *J Am Acad Dermatol* 1987; 16(3 pt 2):673-676.
- Piepkorn MW, Weidner M. Comparable efficacy of 2% minoxidil gel and solution formulations in the treatment of male pattern alopecia. *J Am Acad Dermatol* 1988; 18(5 pt 1):1059-1062.
- McClellan KJ, Markham A. Finasteride: a review of its use in male pattern hair loss. *Drugs* 1999; 57(1):111-126.
- Civatte J, Laux B, Simpson NB, et al. 2% topical minoxidil solution in male-pattern baldness: preliminary European results. *Dermatologica* 1987; 175(suppl 2):42-49.
- Connors TJ, Cooke DE, De Launey WE, et al. Australian trial of topical minoxidil and placebo in early male pattern baldness. *Australas J Dermatol* 1990; 31(1):17-25.
- Katz HI, Hien NT, Prawer SE, et al. Long-term efficacy of topical minoxidil in male pattern baldness. *J Am Acad Dermatol* 1987; 16(3 pt 2):711-718.
- Olsen EA, DeLong ER, Weiner MS. Dose-response study of topical minoxidil in male pattern baldness. *J Am Acad Dermatol* 1986; 15(1):30-37.
- Rushton DH, Unger WP, Cotterill PC, et al. Quantitative assessment of 2% topical minoxidil in the treatment of male pattern baldness. *Clin Exp Dermatol* 1989; 14(1):40-46.
- Savin RC. Use of topical minoxidil in the treatment of male pattern baldness. *J Am Acad Dermatol* 1987; 16(3 pt 2):696-704.
- Shapiro J. Safety of topical minoxidil solution: a one-year, prospective, observational study. *J Cutan Med Surg* 2003; 7(4): 322-329.
- Dallob A, Sadick NS, Unger W, et al. The effect of finasteride, a 5 alpha-reductase inhibitor, on scalp skin testosterone and dihydrotestosterone concentrations in patients with male pattern baldness. *J Clin Endocrinol Metab* 1994; 79(3):703-706.
- Weiss VC, West DP, Fu TS, et al. Alopecia areata treated with topical minoxidil. *Arch Dermatol* 1984; 120(4):457-463.
- Berger RS, Fu JL, Smiles KA, et al. The effects of minoxidil, 1% pyrithione zinc and a combination of both on hair density: a randomized controlled trial. *Br J Dermatol* 2003; 149(2):354-362.
- Shapiro J, Kaufman KD. Use of finasteride in the treatment of men with androgenetic alopecia (male pattern hair loss). *J Investig Dermatol Symp Proc* 2003; 8(1):20-23.
- Lin JH, Chen WC. Finasteride in the treatment of Taiwanese men with androgenetic alopecia: a 12-month open-label study. *Kaohsiung J Med Sci* 2002; 18(8):379-385.
- Norwood OT. Incidence of female androgenetic alopecia (female pattern alopecia). *Dermatol Surg* 2001; 27(1):53-54.
- Van Neste D, Fuh V, Sanchez-Pedreno P, et al. Finasteride increases anagen hair in men with androgenetic alopecia. *Br J Dermatol* 2000; 143(4):804-810.
- Tang PH, Chia HP, Cheong LL, et al. A community study of male androgenetic alopecia in Bishan, Singapore. *Singapore Med J* 2000; 41(5):202-205.
- Brenner S, Matz H. Improvement in androgenetic alopecia in 53-76-year-old men using oral finasteride. *Int J Dermatol* 1999; 38(12): 928-930.
- Olsen EA. Efficacy of finasteride 1 mg in the treatment of androgenetic alopecia in men. *Exp Dermatol* 1999; 8(4):302-303.
- DeVillez RL, Jacobs JP, Szpunar CA, et al. Androgenetic alopecia in the female. Treatment with 2% topical minoxidil solution. *Arch Dermatol* 1994; 130(3):303-307.
- Jacobs JP, Szpunar CA, Warner ML. Use of topical minoxidil therapy for androgenetic alopecia in women. *Int J Dermatol* 1993; 32(10):758-762.

50. Whiting DA, Jacobson C. Treatment of female androgenetic alopecia with minoxidil 2%. *Int J Dermatol* 1992; 31(11):800-804.
51. Whiting DA, Olsen EA, Savin R, et al. Efficacy and tolerability of finasteride 1 mg in men aged 41 to 60 years with male pattern hair loss. *Eur J Dermatol* 2003; 13(2):150-160.
52. Stough DB, Rao NA, Kaufman KD, et al. Finasteride improves male pattern hair loss in a randomized study in identical twins. *Eur J Dermatol* 2002; 12(1):32-37.
53. Roberts JL, Fiedler V, Imperato-McGinley J, et al. Clinical dose ranging studies with finasteride, a type 2 5 $\alpha$ -reductase inhibitor, in men with male pattern hair loss. *J Am Acad Dermatol* 1999; 41(4):555-563.
54. Leyden J, Dunlap F, Miller B, et al. Finasteride in the treatment of men with frontal male pattern hair loss. *J Am Acad Dermatol* 1999; 40(6 pt 1):930-937.
55. Castex-Rizzi N, Lachgar S, Charvéron M, et al. [Implication of VEGF, steroid hormones and neuropeptides in hair follicle cell responses]. *Ann Dermatol Venerol* 2002; 129(5 pt 2):783-786.
56. Otomo S. [Hair growth effect of minoxidil]. *Nippon Yakurigaku Zasshi* 2002; 119(3):167-174.
57. Hoffmann R. TrichoScan: a novel tool for the analysis of hair growth in vivo. *J Investig Dermatol Symp Proc* 2003; 8(1):109-115.
58. Sawaya ME, Keane RW, Blume-Peytavi U, et al. Androgen responsive genes as they affect hair growth. *Eur J Dermatol* 2001; 11(4):304-308.
59. Trüeb RM and Itin P. [Photographic documentation of the effectiveness of 1 mg. oral finasteride in treatment of androgenic alopecia in the man in routine general practice in Switzerland] [Clinical Trial, Clinical Trial, Phase IV, Journal Article, Multi-center Study]. *Schweiz Rundsch Med Prax* 2001; 90(48):2087-2093.
60. Finasteride Male Pattern Hair Loss Study Group. Long-term (5-year) multinational experience with finasteride 1 mg in the treatment of men with androgenetic alopecia. *Eur J Dermatol* 2002; 12(1):38-49.
61. Tsuboi R, Arano O, Nishikawa T, et al. Randomized clinical trial comparing 5% and 1% topical minoxidil for the treatment of androgenetic alopecia in Japanese men. *J Dermatol* 2009; 36(8):437-446.
62. Lucky AW, Piacquadio DJ, Ditre CM, et al. A randomized, placebo-controlled trial of 5% and 2% topical minoxidil solutions in the treatment of female pattern hair loss. *J Am Acad Dermatol* 2004; 50(4):541-553.
63. Olsen EA, Whiting D, Bergfeld W, et al. A multicenter, randomized, placebo-controlled, double-blind clinical trial of a novel formulation of 5% minoxidil topical foam versus placebo in the treatment of androgenetic alopecia in men. *J Am Acad Dermatol* 2007; 57(5):767-774.
64. Van Neste D. Natural scalp hair regression in preclinical stages of male androgenetic alopecia and its reversal by finasteride. *Skin Pharmacol Physiol* 2006; 19(3):168-176.
65. Sawaya ME, Blume-Peytavi U, Mullins DL, et al. Effects of finasteride on apoptosis and regulation of the human hair cycle. *J Cutan Med Surg* 2002; 6(1):1-9.
66. Tang L, Bernardo O, Bolduc C, et al. The expression of insulin-like growth factor 1 in follicular dermal papillae correlates with therapeutic efficacy of finasteride in androgenetic alopecia. *J Am Acad Dermatol* 2003; 49(2):229-233.
67. Leavitt M, Charles G, Heyman E, et al. HairMax LaserComb laser phototherapy device in the treatment of male androgenetic alopecia: a randomized, double-blind, sham device-controlled, multicentre trial. *Clin Drug Investig* 2009; 29(5):283-292.
68. Pierard-Franchimont C, De Doncker P, Cauwenbergh G, et al. Ketoconazole shampoo: effect of long-term use in androgenic alopecia. *Dermatology* 1998; 196(4):474-477.
69. Fischer TW, Hipler UC, Elsner P. Effect of caffeine and testosterone on the proliferation of human hair follicles in vitro. *Int J Dermatol* 2007; 46(1):27-35.
70. Otberg N, Teichmann A, Rasuljev U, et al. Follicular penetration of topically applied caffeine via a shampoo formulation. *Skin Pharmacol Physiol* 2007; 20(4):195-198.
71. Shin HS, Won CH, Lee SH, et al. Efficacy of 5% minoxidil versus combined 5% minoxidil and 0.01% tretinoin for male pattern hair loss: a randomized, double-blind, comparative clinical trial. *Am J Clin Dermatol* 2007; 8(5):285-290.
72. Johnstone MA. Hypertrichosis and increased pigmentation of eyelashes and adjacent hair in the region of the ipsilateral eyelids of patients treated with unilateral topical latanoprost. *Am J Ophthalmol* 1997; 124(4):544-547.
73. Wand M. Latanoprost and hyperpigmentation of eyelashes. *Arch Ophthalmol* 1997; 115(9):1206-1208.
74. Bearden W, Anderson R. Trichiasis associated with prostaglandin analog use. *Ophthalm Plast Reconstr Surg* 2004; 20(4):320-322.
75. Tosti A, Pazzaglia M, Voudouris S, et al. Hypertrichosis of the eyelashes caused by bimatoprost. *J Am Acad Dermatol* 2004; 51(5 suppl):S149-S150.
76. Johnstone MA, Albert DM. Prostaglandin-induced hair growth. *Surv Ophthalmol* 2002; 47(suppl 1):S185-S202.
77. Mansberger SL, Cioffi GA. Eyelash formation secondary to latanoprost treatment in a patient with alopecia. *Arch Ophthalmol* 2000; 118(5):718-719.
78. Mehta JS, Raman J, Gupta N, et al. Cutaneous latanoprost in the treatment of alopecia areata. *Eye (Lond)* 2003; 17(3):444-446.
79. Zaheri S, Hughes B. Successful use of bimatoprost in the treatment of alopecia of the eyelashes. *Clin Exp Dermatol* 2010; 35(4):e161-162.
80. Epstein JS. Evolution of techniques in hair transplantation: a 12-year perspective. *Facial Plast Surg* 2007; 23(1):51-59; discussion 60.
81. Tan Baser N, Cigsar B, Balci Akbuga U, et al. Follicular unit transplantation for male-pattern hair loss: evaluation of 120 patients. *J Plast Reconstr Aesthet Surg* 2006; 59(11):1162-1169.
82. Rouso DE, Presti PM. Follicular unit transplantation. *Facial Plast Surg* 2008; 24(4):381-388.
83. Onda M, Igawa HH, Inoue K, et al. Novel technique of follicular unit extraction hair transplantation with a powered punching device. *Dermatol Surg*, 2008; 34(12):1683-1688.
84. Arase S, Shikiji T, Uchida N, et al. Experimental approaches for the reconstitution of hair in vitro. *Skin Pharmacol* 1994; 7(1-2):12-15.
85. Wu JJ, Zhu TY, Lu YG, et al. Hair follicle reformation induced by dermal papilla cells from human scalp skin. *Arch Dermatol Res* 2006; 298(4):183-190.
86. Yang CC, Cotsarelis G. Review of hair follicle dermal cells. *J Dermatol Sci* 2010; 57(1):2-11.
87. Teumer J, Cooley J. Follicular cell implantation: an emerging cell therapy for hair loss. *Semin Plast Surg* 2005; 19(2):193-200.
88. Price VH, Meneffe E. Quantitative estimation of hair growth. I. androgenetic alopecia in women: effect of minoxidil. *J Invest Dermatol* 1990; 95(6):683-687.
89. Price VH, Roberts JL, Hordinsky M, et al. Lack of efficacy of finasteride in postmenopausal women with androgenetic alopecia. *J Am Acad Dermatol* 2000; 43(5 pt 1):768-776.
90. Barman JM, Pecoraro V, Astore I. Method, technic and computations in the study of the trophic state of the human scalp hair1. *J Investig Dermatol* 1964; 42(6):421-425.
91. Hayashi S, Miyamoto I, Takeda K. Measurement of human hair growth by optical microscopy and image analysis. *Br J Dermatol* 1991; 125(2):123-129.
92. Barth JH. Measurement of hair growth. *Clin Exp Dermatol* 1986; 11(2):127-138.
93. Hoffmann R. A 4-month, open-label study evaluating the efficacy of eflornithine 11.5% cream in the treatment of unwanted facial hair in women using TrichoScan. *Eur J Dermatol* 2008; 18(1):65-70.
94. Gassmueller J, Rowold E, Frase T, et al. Validation of TrichoScan technology as a fully-automated tool for evaluation of hair growth parameters. *Eur J Dermatol* 2009; 19(3):224-231.

95. Gassmueller J, Hoffmann R, Webster A. Topical fulvestrant solution has no effect on male and postmenopausal female androgenetic alopecia: results from two randomized, proof-of-concept studies. *Br J Dermatol* 2008; 158(1):109–115.
96. Blume-Peytavi U, Kunte C, Krisp A, et al. Comparison of the efficacy and safety of topical minoxidil and topical alfatradiol in the treatment of androgenetic alopecia in women. *J Dtsch Dermatol Ges* 2007; 5(5):391–395.
97. Van Neste D, Trüeb R. Critical study of hair growth analysis with computer-assisted methods. *J Eur Acad Dermatol Venereol* 2006; 20(5):578–583.
98. Rushton DH, de Brouwer B, de Coster W, et al. Comparative evaluation of scalp hair by phototrichogram and unit area trichogram analysis within the same subjects. *Acta Derm Venereol* 1993; 73(2):150–153.
99. Cohen B. The cross-section trichometer: a new device for measuring hair quantity, hair loss, and hair growth. *Dermatol Surg* 2008; 34(7):900–910; discussion 910–911.
100. Robbins CR. *Chemical and Physical Behavior of Human Hair*. 4th ed. New York Berlin Heidelberg: Springer, 2002:483.
101. Lupton CJ, McColl A, Stobart RH. Fiber characteristics of the Huacaya Alpaca. *Small Rumin Res* 2006; 64(3):211–224.
102. Wortmann F-J, Schwan-Jonczyk A. Investigating hair properties relevant for hair “handle”. Part I: hair diameter, bending and frictional properties. *Int J Cosmet Sci* 2006; 28(1):61–68.
103. Gunn DA, Rexbye H, Griffiths CE, et al. Why some women look young for their age. *PLoS One* 2009; 4(12):e8021.
104. Sinclair RD, Schwartz JR, Rocchetta HL, et al. Dandruff and seborrheic dermatitis adversely affect hair quality. *Eur J Dermatol* 2009; 19(4):410–411.

# Assessing the efficacy of moisturizers

Whitney Hannon

## INTRODUCTION

This chapter gives an introductory background to practitioners in cosmetic dermatology who wish to better understand the science behind efficacy claims for moisturizers. In an age of evidence-based medicine and savvy consumers, it is increasingly important to be able to understand, critically evaluate and summarize the experiments used to evaluate the efficacy of moisturizers.

One of the first challenges to the clinician is actually obtaining information about moisturizer efficacy. Most of the studies are not published because they are proprietary information. Information can be requested from companies but can be time consuming to obtain. The information that is readily available is often incomplete (e.g., only available in abstract form) or in difficult or expensive to access journals or books. Once an article is obtained, the clinician is faced with the second challenge of understanding a study that is often filled with technical jargon and unfamiliar instruments. Once the study is deciphered, the third challenge is for the clinician to critically appraise the validity of the information. For example, the clinician needs to ask, "Was the experimental design of this study good enough to warrant trusting the conclusions?" One example of a recommended moisturizer study design is available for reference in Table 59.1. Fourthly, complex machines are often used to make skin measurements. The clinician needs to ask, "Was the machine used properly in this experiment?" and on a more advanced level, "Did this machine really accurately measuring the variable claimed during the experiment?" A checklist of other important questions to ask when assessing the performance and validity of a machine has been developed by Serup (1).

Besides the difficulties already mentioned, there are other significant but subtler issues that need to be taken into account. For example, moisturizers are that moisturizers are often complex mixtures of ingredients that may have interactive properties. In other words, the composition of a moisturizer is more complex than simply the sum of its independent ingredients. Interactions may occur between water-binding substances (2) and theoretically also between any of the other ingredients including the vehicle. In addition, it has been observed that the individual component has different properties when measured individually than when measured as part of a combination (3).

In summary, the quest to obtain reliable, useful information on the efficacy of moisturizers encounters three main categories of difficulties: problems with the availability/accessibility of information, problems with the experimental design, and problems with the measurement technologies. Table 59.2 lists specific issues in each of these categories, and the implications that these problems could have on the interpretation and validity of the information. This chapter attempts to assist the busy clinician to overcome these challenges by reviewing the

literature, translating some of the jargon and identifying some of the most useful and comprehensive evidence-based references.

## SUMMARY OF BIOENGINEERING TECHNIQUES

A variety of bioengineering techniques have been used to assess the efficacy of moisturizers on the human stratum corneum. These techniques can be divided into measurements of the following:

1. Skin surface contour
2. Desquamation
3. Elasticity (parallel to skin plane)
4. Elasticity (perpendicular to skin plane)
5. Other mechanical techniques
6. Indirect electrical properties
7. Spectroscopy or thermal transfer
8. Transepidermal water loss (TEWL)
9. Stratum corneum imaging
10. Optical characterization of skin properties

The Appendix gives details of the techniques, some of the researchers involved in the development of the technology, names of different machines, variables measured, principles behind the technologies, and their respective advantages and disadvantages.

Many authors have reviewed and compared these technologies (4–6). Marks (7) took a unique approach by using an arbitrary scale to compare the reproducibility, sensitivity, directness of measurement, capability for quantization, standardization, cost-effectiveness, ease of use, and convenience.

## SUMMARY OF EFFICACY DATA BASED ON STUDY TYPE AND BIOENGINEERING TECHNIQUE

Gabard (8) proposed a useful classification for studies on the efficacy of moisturizers. He divides the studies into five main types.

1. Single application to normal skin
2. Multiple application of moisturizers over time to normal skin
3. Moisturizer applied to experimentally irritated skin (one large irritant insult)
4. Moisturizer applied to experimentally irritated skin (mild irritant applied repeatedly over time)
5. Clinical studies in which moisturizer was applied to groups of patients with various conditions

To allow evidence-based comparisons, these study types should be further divided by the bioengineering technique used. There are very few reviews available summarizing moisturizing efficacy studies. Some of the more comprehensive reviews and their conclusions are summarized in the paragraphs that follow.

**Table 59.1** Recommended Study Design for Moisturizer Efficacy Studies

Category	Details	Description
Design		Double blind with contralateral, randomly assigned comparison of treated vs. untreated areas.
Methods	Location	Volar forearm or anterior lower leg.
	Size of test area	4 cm × 4 cm.
	Concentration	1–2 mg/cm <sup>2</sup> .
	Application method	Gently rub hydrated product into test area.
Measurements	Baseline	Reading 10–30 min before application of product.
	Following application	Readings on treated and untreated area every 10–15 min.
	Total duration	60–180 min.

Source: From Ref. 14.

**Table 59.2** Problems with Bioengineering Studies on Moisturizers

Category of problem	Issue	Implications
<i>Experimental design</i>		
Patient selection	Volunteers	May not be representative of consumer population
	Histories not clearly stated, age/sex not always stated	Population in unknown; biased population; clinical extrapolation is difficult
Study size	Tends to be small	May not be enough subjects to satisfy study objective
Controls	Often inadequate	Cannot account for changes during experiment
	Most studies only measured on one side rather than contralateral side	Need to control for variation on different sides of body
	Often not stated whether or not other moisturizers/ beauty products were used	Effects may be due to other moisturizers
Materials studied	Often studies not blinded and no placebo group	Potential for bias
	Materials used or concentrations not always stated	Cannot compare studies easily; moisturizer effects are presumably dose responsive
Measurements	Range of concentrations often was not studied	No information on dose response
	Complex mixtures studied, not broken down into parts so that they could be compared and evaluated	Unable to separate effects
	Not enough time points	Gaps in information about time course
Statistics	Often did not assess both TEWL and SC at the same time	Cannot make conclusions about hydration state
	Three-prong approach often not used: panelist self-appraisal, expert grader evaluation and relevant instrumental measures	
General	Statistics not always used to analyze data	Comparisons have no scientific basis
	If statistics used, <i>p</i> values not always stated	No knowledge of level of significance
General	Not enough studies	No verification of findings
	Few materials studied	Large amount of materials have unknown efficacy
<i>Bioengineering methods</i>		
Operator dependent	Potentially improper use of machines	Misleading data
	Some studies have no statement of ambient conditions	Misleading data
Information access	Journals/books not easily accessible; full details not published	Missing data

Source: From Ref. 15.

Hannon reviewed data on the indirect electrical techniques (capacitance, conductance, impedance) and identified 20 studies of Gabard study design type 1 (single application of moisturizer to normal skin) (9). The conclusions are summarized as follows. Glycerol, urea and petrolatum were the best studied substances. One application of urea, glycerol, petrolatum, hyaluronic acid or hydrogenated phosphatidylcholine was capable of increasing stratum corneum hydration for at least several hours: urea for at least six hours even if washed off, glycerol for at least six hours even if wiped off, and petrolatum for at least two hours (but not if it is wiped off). Water itself has a hydrating effect in the short term but eventually results in dehydration. The studies had many limitations especially in

the area of controls. For example, many studies did not control for vehicle type (a very important variable) or ingredient interactions. Others failed to control for the following complexities associated with indirect electric measurements: for example, that (i) the capacitance ratio (moisturizer-treated skin capacitance/untreated skin capacitance) varies over time depending on type of moisturizer or (ii) electrical readings are not always proportional to the water present depending on the substance or (iii) each component of a moisturizer has its own electrical properties that can be a source of false positive results (10).

Sivamani (11) reviewed the data on various mechanical (tribological) techniques and found that there were limited studies for Gabard type 1 and type 2 experimental designs.

Sivamani concluded that the water and moisturizers had similar effects on the friction coefficient except the effects of the creams/emollient lasted for hours and the water effects only lasted 5 to 20 minutes. Important variables in studies included the temperature of creams, anatomic location, age of patient and design of the test apparatus.

Agache (12) reviewed data on torsional measurements of skin elasticity (twistometry) for both Gabard type 1 and type 2 study designs. The conclusions were based on a limited number of studies. Some of the results were somewhat contradictory. In most studies, glycerol and lactic acid had longer lasting effects than petrolatum. In one study, glycerol demonstrated increased elasticity up to one week. Other important variables noted were an increase in skin temperature with increased elasticity.

Crowther (13) reviewed data on confocal Raman microscopy for Gabard study design types 1, 2, 3, and 4. Conclusions were that little difference is observed in moisturization on day 1. Over a two-week period, use of moisturizers containing niacinamide was associated with increased total skin hydration. Important variables to control included osmotic changes in skin based on moisturizer properties and changes in stratum corneum thickness based on different types of moisturizers.

In summary, there have been few detailed reviews of moisturizer studies using bioengineering techniques. More work needs to be done to summarize and analyze the extent of available information.

## CONCLUSIONS

There are multiple challenges facing the clinician who wishes to understand the scientific basis behind moisturizer efficacy claims, including access to information, understanding the information and making sure the study design and technologies used are valid. There is an urgent need to perform meta-analyses (quantitative and/or qualitative) of the studies categorized by study type and bioengineering technique to have more clinically relevant information on the efficacy of moisturizers. For those interested in exploring the topic of moisturizers or noninvasive bioengineering techniques more profoundly, some textbook references have been listed under section "Additional Reading."

## ADDITIONAL READING

- Serup J, Jemec GBE, Grove GL, eds. *Handbook of Non-Invasive Methods and the Skin*. Boca Raton: CRC Press, 2006.
- Rawlings AV, Leyden JJ, eds. *Skin Moisturization*. 2nd ed. New York: Informa Health Care, 2009.
- Loden M, Maibach HI. *Dry Skin and Moisturizers: Chemistry and Function*. 2nd ed. Boca Raton: CRC Press, 2005.

## REFERENCES

- Serup J. How to choose and use non-invasive methods. In: Serup J, Jemec GBE, Grove G, eds. *Handbook of Non-Invasive Methods and the Skin*. Boca Raton: CRC Press, 2006:9-13.
- Swanbeck G. Carbamide and other active substances in moisturizers. In: Abstract of paper presented at the Regional Symposium on Rationales behind Moisturizers in Dermatology, Copenhagen, Denmark, June 1989. *Bioeng Skin* 1988; 4:383.
- Loden M, Lindberg M. The influence of a single application of different moisturizers on the skin capacitance. *Acta Derm Venerol* 1991; 71:79-82.
- Borroni G, Zaccone C, Vignati G, et al. Dynamic measurements. In: Elsner P, Berardesca E, Maibach HI, eds. *Bioengineering of the Skin: Water and the Stratum Corneum*. Boca Raton: CRC Press, 1994: 217-222.
- Stab F, Sauermaun G, Hoppe U. Evaluation of moisturizers. In: Wilhelm KP, Berardesca E, Maibach HI, eds. *Bioengineering of the Skin: Skin Surface Imaging and Analysis*. Boca Raton: CRC Press, 1997:315-330.
- Barel AO. Product testing: moisturizers. In: Elsner P, Berardesca E, Wilhelm KP, et al., eds. *Bioengineering of the Skin: Skin Biomechanics*. Boca Raton: CRC Press, 2002:241-256.
- Marks R. Methods to evaluate the effects of skin surface modifiers. In: Frost P, Horwitz SN, eds. *Principles of Cosmetics for the Dermatologist*. St. Louis: CV Mosby, 1982:50-58.
- Gabard B. Testing the efficacy of moisturizers. In: Elsner P, Berardesca E, Maibach HI, eds. *Bioengineering of the Skin: Water and the Stratum Corneum*. Boca Raton: CRC Press, 1994: 147-170.
- Hannon CW, Maibach HI. Efficacy of moisturizers assessed through bioengineering techniques. In: Baran R, Maibach HI, eds. *Textbook of Cosmetic Dermatology*. 3rd ed. London: Informa Health Care, 2004:573-612.
- Jemec B. Inherent capacitance of moisturizer creams: a source of false positive results. *Skin Pharmacol Appl Skin Physiol* 2000; 13: 182-187.
- Sivamani RK, Wu G, Maibach HI, et al. Tribological studies on skin: measurement of the coefficient of friction. In: Serup J, Jemec GBE, Grove G, eds. *Handbook of Non-Invasive Methods and the Skin*. Boca Raton: CRC Press, 2006:215-224.
- Agache P. Twistometry measurements of skin elasticity. In: Serup J, Jemec GBE, Grove G, eds. *Handbook of Non-Invasive Methods and the Skin*. Boca Raton: CRC Press, 2006:601-616.
- Crowther JM, Matts PJ. Measuring water gradients using confocal raman microscopy. In: Rawlings AV, Leyden JJ, eds. *Skin Moisturization*. New York: Informa Health Care, 2009:427-431.
- Barel AO, Clarys P. Measurement of epidermal capacitance. In: Serup J, Jemec GBE, eds. *Handbook of Non-Invasive Methods and the Skin*. Boca Raton: CRC Press, 1995:165-172.
- Grove GL. Noninvasive techniques for assessing moisturizers. In: Waggoner C, ed. *Clinical Safety and Efficacy Testing of Cosmetics*. New York: Marcel Dekker, 1990:121-148.



**APPENDIX: BIOENGINEERING TECHNIQUES FOR ASSESSING MOISTURIZER EFFICACY**

1. Skin surface contour
2. Desquamation
3. Mechanical bioengineering techniques to measure elasticity (parallel to skin surface plane)
4. Mechanical bioengineering techniques measuring elasticity (perpendicular to skin surface plane)
5. Other mechanical properties
6. Indirect electrical properties
7. Spectroscopy or thermal transfer
8. TEWL
9. Stratum corneum imaging
10. Optical characterization of skin properties

**Appendix Table 1** Bioengineering Techniques for Skin Surface Contour Evaluation

Technique	Developer/machines	Parameters measured/calculated	Principles	Advantages	Disadvantages
Low-power surface magnification (1)	8 × lens magnifier	Skin surface contour	Place mineral oil on skin; cover with coverslip; observe skin under low power.	Can visualize epidermis, epidermal-dermal junction, and papillary dermis. Easy, noninvasive method. Augments naked-eye observation skills.	Technique has learning curve. Hard to visualize dry, scaly skin with this technique.
Profilometry (mechanical)	Perth-o-meter, 1971 (2) Surfometer, 1975 (3) Surfcom, 1979 (4) Talsurf, 1979 (5) Anaglyphographie, 1982 (6)	Skin surface contour; roughness parameter	Cast replica of skin in silicone rubber is measured with a computerized stylus instrument, which produces plots of data. Valley and peak profile of SC flattens with hydration.	Replica measurements give absolute data. Can evaluate hydration status.	Complex and slow process. The application of silicone rubber may disrupt the surface; fine lines may be effaced when rubber cools; scales may be removed from subject. Needs a smooth even surface (too many hair follicles, scars, tattoos, detergents, skin damage or scaling can increase error). Stylus geometry can introduce errors (7). Sources of interobserver variability are high-pass filters, low-pass filters and sampling intervals (7). Expensive (8). Profilometry can identify products that decrease amount of wrinkles but does not reveal mechanisms or safety of these products (irritants, e.g., decrease wrinkling). Results in 2-D only. Show topography in one direction only. Acquisition time = 8 min. Accuracy = 10 <sup>-3</sup> mm.
Profilometry (optical)	Corcuff, 1981 (9)	Skin surface contour; roughness parameters; wrinkle	Cast replica of skin in silicone rubber is measured with an optical scanner (laser beam).	Gives absolute data; operating time reduced over mechanical method; noncontact sensor; 3-D data possible; fast acquisition time ≤ 1 min.	Complex and slow process. The application of silicone rubber may disrupt the surface. Needs a smooth, even surface (too many hair follicles, scars, detergents, skin damage or scaling can increase error). Also unable to measure soft, fragile liquid and high-temperature objects. Does not measure in real time. Availability is limited because of sophistication. Accuracy = 10 <sup>-3</sup> mm.

(Continued)

**Appendix Table 1** Bioengineering Techniques for Skin Surface Contour Evaluation (Continued)

Technique	Developer/machines	Parameters measured/calculated	Principles	Advantages	Disadvantages
Laser profilometry with densitometry	Barton, 1987 (10) Gormley, 1985 (11)	Contour; roughness parameters; wrinkle quantification	Photographic negative of skin taken under standard light (oblique illumination with incident angle of 25°). Shadows formed are scanned microdensitometrically by a computer and gray level assigned. The relief is reconstructed indirectly from gray level, and, using appropriate algorithms, slopes and roughness parameters of relief can be calculated.	Rapid measurement of skin surface relief without cumbersome equipment (12). Good for following clinical progression of scaling disorders. Most accurate of all profilometry techniques (10 <sup>-5</sup> mm). Can plot 10 <sup>5</sup> points.	Only provides a reconstruction and not an exact image, so smaller features may be overshadowed by larger ones and omitted from analysis (12). Less sensitive in screening normal volunteers. Very slow acquisition time = 10–30 min. Cannot measure soft, fragile, liquid objects and objects at high temperature.
Proliferometry (interference)	Altmeyer, 1995 (13) Lagarde, 2001 (14) Dermatop (Eotech)	Surface contour	Calculates a phase image from the interference fringe image projection.	Can determine altitude at each point. Plots more points (10 <sup>6</sup> ) than any other proliferometry method. Fast acquisition = 1 min.	Accuracy = 5 × 10 <sup>-3</sup> mm.
Transparency (transmission) proliferometry	De Paepe, 2001 (15) Skin Visiometer SV600	Thickness, surface contour	Measures the variation of absorbance which is related to transparency and therefore thickness of the replica according to Beer-Lambert's law.	Measures small plane area of 1 cm <sup>2</sup> . Can plot 10 <sup>5</sup> points. Very fast acquisition ≤ 1 min.	Very shallow depth of field (500 μm). Accuracy = 10 × 10 <sup>-3</sup> mm.
In vivo image analysis (digital image processing)	Picton, 1976 (16) Taylor, 1978 (17) Quantimet (16) Magiscan (17)	Surface contour	Using video camera, can record skin surface features directly. Signal is digitized using a high-speed analog/digital converter and arranged into an array of picture points. The picture points are introduced into a digital image processor that interfaces with a minicomputer. Filters (mathematical sieves) can be used to enhance detail.	More objective, quantifiable images (shape, color), than clinic notes. Interactive; can be queried, altered, analyzed automatically and rapidly in real time. Permanent record. data easily stored. In vivo, direct measurement of surface possible. Good for evaluation of low to moderate dryness.	Inconvenient. Technique less useful for very dry skin.
Scanning microdensitometry of macrophotographs	Marshall, 1983 (18)	Surface contour; roughness parameters	Low-magnification photomicrographs are taken under standardized light scanned with microdensitometer, which records shadows and highlights and produces a contour line similar to profilometry.	Good for the assessment of clinical progression in patients with scaling disorders.	Not so good for normal skin assessment; still needs additional improvements.

Note: Topography measurements can be used to demonstrate changes in amount of wrinkling and state of stratum corneum hydration as noted by attenuation of the relief due to increase in turgor.

**Appendix Table 2** Bioengineering Techniques to Measure Desquamation

Technique	References	Principles	Advantages	Disadvantages
Squametry of tape strippings	Wolf, 1936 (19) Jenkins, 1969 (20)	Tape pressed against skin; outermost portion of skin sticks to tape and keeps topographical relationship and desquamation pattern. Tapes are processed. Scales are sized and counted. Samples stained and viewed with microscope (visual scoring).	Simple, noninvasive, painless, more reproducible, objective and consistent than traditional grading systems.	Need to assure clean conditions. Tapes not necessarily well characterized in terms of component properties. Need to precut tape under clean conditions. All squametry techniques are better as a screen for dry skin than as a quantitative method to assess skin moisturizers (21).
Sticky slide (22)	Goldschmidt (1967); Dermatology Lab and Supply Co.	Prepare slide by coating with adhesive solution and allow organic solid to evaporate. Press on skin, leave on skin for a few seconds, remove and process.	More reproducible, objective, and consistent than traditional clinical grading systems. Quantification/standardization of desquamation possible. More quantitative than skin scraping because fixed area is sampled and loss of material to air currents is more controlled.	Prepared slides have limited life due to gradual air oxidation of adhesive surface. Need skill and practice to perform. Need careful storage and handling to prevent contamination.
Skin surface biopsy with microscopy	Marks, 1971 (23)	Cyanoacrylate glue is spread on a flexible plastic slide and applied firmly to skin for 30 sec. Three to five layers of corneocytes are detached, stained, viewed under microscope, and classified into one of five xerosis classifications.	Simple, noninvasive, painless. Removes more stratum corneum than pressure-sensitive adhesives.	More difficult to standardize. Skill involved.
D-Squame® (CuDerm Co., Dallas, Texas, U.S.) analysis using light transmission	Serup, 1989 (24)	Small transparent tape disks are pressed against the skin; analysis of disks using light transmission.	Simple, noninvasive, painless; standardized, easy to use.	Small disk size prone to sampling error. May need to delipidize skin to remove scales.
D-Squame analysis using image analysis	Schatz, 1993 (25)	Small transparent tape disks are pressed against the skin; analysis of disks using image analysis.	Chromometry may add additional precision.	Image analysis can be expensive but more cost-effective machines are being developed (26).
Adhesive disk squametry combined with Chromameter (Minolta) and image analysis	Pierard, 1992 (27)	Small transparent adhesive disks are pressed against skin. Corneocytes stained and viewed under microscope, and intensity of stain measured with a chromameter. Quantitative xerosis (based on stain intensity). Image analysis reveals number, thickness and size of squames.	Simple, noninvasive, painless. Allows quantitative assessments of xerosis. Eliminates many of difficulties involved with tape and sticky slides because it is specially formulated and readily available. Three standard sizes. Easy storage and use.	Small disk size more prone to sampling error. May need to delipidize skin to remove scales more effectively. Image analysis is expensive/technical luxury (28).

Source: From Ref. 22.

**Appendix Table 3** Mechanical Bioengineering Techniques to Measure Elasticity (Parallel to Skin)

Technique	Parameters measured	Machines available/ developer	Principles	Advantages	Disadvantages
Extensometry	Material constants	Extensometer <sup>®</sup> Thacker, 1977 (29) Gunner, 1978 (30)	The arms of two strain gauges are stuck to the skin surface using adhesive tape. By means of a lead screw and carrier, a motor and gear combination moves one arm away from the other at a constant rate, stretching the skin between the tabs. The separation of tabs is measured with a linear variable differential transformer transducer, and the force developed in the skin is measured by strain gauges attached to the reduced sections of the arms. Recoil apparatus can be installed to measure extension-time characteristics of skin when deforming force is removed (30).	Can be handheld. In vivo measurements possible.	Strain gauges are stiff, and may impose frictional forces. Some systems are bulky and not convenient for clinical use. Technique deforms fiber network in skin so sequential measurements may be increasingly effected by prior measurements.
GBE	DSR (analogous to Young's elastic modulus); loss angle (stiffness, softness, and compliance)	Hargens et al., 1977 (31)	GBE measures displacement of skin in response to a rapidly oscillating force placed next to its surface. Dynamic stress-strain loop appears on oscilloscope, which can be analyzed. Application of moisturizer to the skin surface results in a decrease in the DSR and a concomitant increase in the loss angle.	Good for quantifying stiffness in surface plane of skin, i.e., SC. High degree of correlation between elastic modulus measurements and visual assessments of skin by a trained grader. Sensitive enough to measure changes in SC induced by topically applied agents or mechanical disruption (31). Can apply small forces. Measurement is direct rather than implied from inference, as is the case with electrical conductivity or sonic propagation.	May measure dermal components as well. Changes perceived by trained subjects may not correspond to GBE measurements. Manual stretching of skin can change baseline. Thickness of SC, size and geometric arrangement of corneocytes, and chemical composition differences may influence measurements (31).
Linear skin rheometer	DSR	Matts, 1998 (32)	Has the same measuring principles as GBE but none of the components. Instead of a magnet/solenoid as in the GBE, there is a force-controlled miniature DC servo, gearing and lead screw. Instead of the linear variable differential transformer, there is a calibrated load beam. The machine interfaces with a portable computer containing user-friendly software.	More compact, efficient with greater inherent accuracy than the GBE and reduced service requirements. It can differentiate between varying degrees of SC hydration (33).	Not readily available. Technique deforms fiber network in skin so sequential measurements may be increasingly effected by prior measurements.

Torque meters (disproportional strain measurements)	Torque and phase angle extensibility (resistance to stretch), viscoelastic properties	Viasblom, 1967 (34) Finlay, 1970 (35) Twistometre <sup>®</sup> (Leveque, L'Oreal) Dermal Torque Meter <sup>®</sup> (Dia-stroon Ltd., Andover, U.K.) Barbenel, 1977 (36)	Disk attached to skin with adhesive. Weak, constant torque applied to rotating disk. Movement of disk monitored by rotational sensor. Fixed guard ring delineates area. When distance between disk and guard ring is less than 1 mm, extensibility reflects SC resistance to stretch. Microprocessor computes main parameters. Immediate rotation corresponds to immediate extensibility, followed by slow increase corresponding to "creeping" or the viscous and plastic skin characteristics.	Sensitive in both short- and long-term studies rating hydrating efficacy. Clear correlation between SC extensibility and severity of dryness. Measurements made parallel to skin surface, so effect of links between dermis and hypodermis are minimized. Can be used to describe mechanical changes in skin with aging, sun exposure, and scleroderma (37). Weibull or extreme-value distribution is more accurate and sensitive than other torsion methods (38). Can study elastic tissues or viscous parameters in living soft tissue.	Standardization not yet complete (38). Technique deforms fiber network in skin so sequential measurements may be increasingly effected by prior measurements.
Mechanical impedance	Point impedance	Franke, 1950 (39) Von Gierke, 1952 (40) Swept-frequency viscoelastometer (40)	Impedance head is mounted on an electromagnetic actuator or shaker, which is driven by a swept sinusoidal voltage. Corrected force and velocity signals are inputted into RMS circuits and then to a log ratio amplifier to obtain output proportional to log mechanical impedance. Phase angle between force and velocity signals obtained via a phase meter. Phase angle and log impedance used as vertical drive signals to a multichannel display multiplexor on an XY storage display oscilloscope. Horizontal drive obtained from frequency to voltage converter and log amplifier. Thus, real-time plots of log Z vs. log of frequency can be obtained.	Can study elastic tissues or viscous parameters in living soft tissue.	Technical difficulties still need to be overcome. Technique deforms fiber network in skin so sequential measurements may be increasingly effected by prior measurements.

Abbreviations: GBE, gas-bearing electrodyamometer; DSR, dynamic spring rate.

**Appendix Table 4** Mechanical Bioengineering Techniques Measuring Elasticity (Acting Perpendicular to Plane of Skin Surface)

Technique	Parameters measured/calculated	Machines/developer	Principles	Advantages	Disadvantages
Suction chamber (disproportional superficial strain)	Stiffness (distensibility, resilient distensibility, hysteresis); elasticity (RER)	Cutometer (SEM 474 (Courage and Khazaka); Cutometer <sup>®</sup> 580MPA (41)	A suction probe is applied vertically on the skin with a constant pressure. The amount of skin elevation is measured using an optical system, which measures the decrease in intensity of an infrared beam. The instrument interfaces with an IBM personal computer, and standard software provided allow the storage of data concerning important variables and graphical display of stress-vs.-strain and strain-vs.-time curves.	More useful for cosmetological purposes, which aim to measure mechanical properties of epidermis and papillary dermis. Measurements can be enhanced by use of optical elastography (42). Cutometer 580MPA (41) was developed for use on foot.	Type of strain measured may be irrelevant to common practice. May still measure mechanical properties of the deeper layers of dermis and subcutis to an unknown extent; limited in range of viscoelasticity; complex measuring units; data can be difficult to interpret; cannot measure viscoelasticity of more rigid skin; cannot evaluate skin anisotropy. Deforms skin making sequential measurements difficult.
Suction chamber (proportional full-thickness strain)	Material constants (stiffness, resilience, distensibility); hysteresis; elasticity (RER)	Grahame, 1970 (43) Gniadecka, Serup (Dermatflex A, Denmark) (44), Serup (Dermalab) (45)	A suction probe is placed directly on the skin. An electronic sensor in the probe measures the amount of skin elevation, by measuring the electric capacitance between the skin surface and the electrode placed in the top of the suction chamber. The data are collected and can be visualized. Skin distensibility and hysteresis increase slightly after epidermal moisturizing (46).	Larger probe is more useful for medical and dermatological applications, e.g., in scleroderma and chronically inflamed skin. Dermalab can be mounted with special probes to measure transepidermal water loss and skin hydration as well.	Correlation of separate parameters of skin mechanical properties with structural elements of skin not fully elucidated. Must control for numerous biological and environmental variables (47). Must avoid repeated measurements at same site for at least 1 hr because of skin deformation.
Dermagraph	Distensibility, relaxation, and elasticity	Sclerimeter <sup>®</sup> (48), Dermagraph (49)	A vacuum probe is placed on skin. Constant vacuum is applied for 6 sec and the amount of aspirated skin (mm) is measured (distention phase). There is then 4 sec of phase of slow relaxation (elastic retraction).	Good intra and interrater reliability. Able to measure accurately and rapidly different areas relevant to patients with scleroderma.	Not readily available, some anatomic areas more difficult to measure reliably. Normal skin more difficult to measure reliably. Deforms skin making sequential measurements difficult.
Levarometry, tonometry	Index of deformability; skin extensibility (skin slackness); biological elasticity	Levometer Dikstein, 1981 (50) and Gartstein, 1990 (51) Tonometry Pierard, 1980 (52)	The skin is attached [using Perspex disk and double adhesive tape (Dikstein), or cyanoacrylate (Pierard) or vacuum (Gartstein) with (Pierard) or without (Dikstein) a guard ring] to a counterbalanced measuring rod. Different weights can be applied, elevating the skin. For Dikstein's levorometer, the rod is attached to a linear variable differential transformer, and this output is recorded graphically.	The method is sensitive and reproducible. Topical applications or environmental conditions probably do not affect measurements (53). Highly discriminating between old and young skin and old female and old male skin.	Not currently commercially available. Deforms skin making sequential measurements difficult.

Ballistometry (54)	Coefficient of restitution (amount of energy returned to the tissue)	Tosti, 1977 (55) Ballistometer Integrated Dynamic Rebound analyzer PC-based ballistomer (56)	Measurement of a drop impact of a body onto the skin.	Noninvasive. Easy to use. No probes attached to skin. Instrument is cheaper than dynamometer. Good for measuring elastic parameters in deeper dermal structures. Can measure differences in elastic modulus between young and old, various body sites and changes after pharmaceutical treatment. Can obtain a lot of data fast.	Cannot obtain data on status of stratum corneum, as one can from shear measurement. Gives only an indirect indication of underlying tissue changes. Deforms skin making sequential measurements difficult.
Indentometry (57)	Skin compressibility	Schacle Elastomer, 1912; Kirk, 1949; Tregear, 1965; Robertson, 1969; Daly, 1974; Pierard, 1984; Dikstein, 1981 (50)	A circular piece of plastic material attached to a weighted metal rod is applied perpendicularly to the skin to indent the skin. The rod is counterbalanced so that the net pressure in the system is a given value. The measuring rod is loaded with specially constructed weights increasing the baseline pressure to the desired level (50). The rod is attached to a linear variable differential transformer, and the output of the deformation curve can be plotted using various methods.	Good for measuring water state of ground substance—elastin network in dermis. Most useful in evaluating edematous skin conditions and altered water handling of the dermis.	Not the best method to discriminate between old and young skin or female and male skin. Deforms skin making sequential measurements difficult.

Abbreviation: RER, relative elastic retraction.  
Source: From Ref. 58.



**Appendix Table 5** Other Mechanical Bioengineering Techniques

Technique	Parameters measured/calculated	Machines/developer	Principles	Advantages	Disadvantages
Coefficient of friction devices	Coefficient of friction (oiliness/greasiness)	Rotating wheel (Teflon Newcastle friction meter); resolving ground glass disk; sliding sled, modified viscometer	Friction of human skin in vivo can be measured by determining how much force is required to drag object across skin surface; smoother or drier skin theoretically needs less force.	Good for screening topicals for after-feel greasiness (59). Some machines are portable. Measurements with Newcastle machine can correlate with sensory scores of smoothness. Can reveal underlying defects not seen at first glance.	Interpretation of differences in frictional properties between products are very complex. Moisturizers can increase friction as a result of increased contact area. Lubricants make skin more slippery. Somewhat invasive
Scratch resistance test	Hardness, softness	Prall, 1973 (60)	A stylus just visibly scratches skin; measures lowest pressure load.	Can reveal underlying defects not seen at first glance.	Somewhat invasive
Durometer (61)	Hardness	Durometer model 1700 type 00 (Rex Gauge) (62)	A calibrated gauge with spring loaded interior that senses hardness by placing an indentation load on the specimen. It registers linearly the relative degree of hardness on a scale of units 0–100.	Very simple to use, portable, handheld; highly reproducible. Good for measuring scleroderma, lipodermatosclerosis, and neuropathic foot hyperkeratosis.	Measurements should be made in the supine position. May be insensitive in areas with decreased subcutaneous tissue.
Microindentometer	Pliability, hardness	Indentometer. Guibarra, 1979 (63); Microindentometer Graves, 2002 (64)	Indentation of the SC by a needle is opposed by the horny layer, and this force of reaction is monitored by a force transducer.	One of the few devices available to measure pliability and hardness of SC.	Must immobilize area that is being measured since movement or vibration will alter measurements. Needs further development to eliminate inertial artifacts.
Acoustic spectrometer (65)	Softness, hydration level; energy loss of viscous component of skin; elastic modulus	Tronnier, 1952 (66); Potts, 1983 (67); Torgalkar, 1981 (65)	Vibration device in audible range gives small-amplitude oscillations normal to skin surface with second stylus as comparison. Spectrum analyzer can calculate time for shear waves to travel and degree of amplitude dampening. Resonance frequency can be measured. The more SC hydration, the lower the resonance frequency. Energy loss can also be calculated. Can be used as predictive measure. Indirect measure of hydration state. Correlated with subjective assessments of moisturization.	Can be used as predictive measure. Indirect measure of hydration state. Correlated with subjective assessments of moisturization.	Thickness of horny layer, thickness and tension of the skin and nature of underlying tissues can be sources of error.

Viscoelasticity skin analyzer	Elasticity, SWP	Sarvazyan, 1990 (68); Vexler, 1999 (69)	Probe consists of 3 piezoelectric transducers (central transmitter with two receivers equidistant on either side). Transmitter produces a tangential oscillatory deformation on the surface of the skin (SWP) in the acoustic frequency range. SWP is calculated from the time of flight of signal to transmitter. Average reading displayed on LCD.	Allows anisotropic measurements; compact; portable, user friendly; high accuracy; reproducible readings. Measurements using this technique do not deform the skin as with distortion, rotation, stretch, or suction, so sequential measurements are possible. Allows measurements of upper skin layers without influence of subdermis.	Not readily available.
Tactile sensor Venustrom <sup>®</sup> (70)	Changes in resonant frequency ( $\Delta f$ ) correlate with spring constant $k$ and stiffness; elasticity	Omata et al., 1999 (71); Sakai, 2000 (70)	Sensor with resonant frequency is pressed and released from the skin at a constant rate. Depth and pressure are determined allowing hysteresis curve/ $\Delta f$ calculation.	Simple. Allows rapid determination of multiple stiffness parameters. Correlated with firmness (dehydration of skin), ratio of acidic amino acids and elasticity.	Significance of correlation needs further investigation.
Cohesography	Intracorneal cohesion measurements	Nicholls, 1971; Marks, 1977 (72)	After hydrating SC, there is a drop in intracorneal cohesion. Drop follows same magnitude as flattening in surface contour, and changes are of same order of magnitude (72).	Able to assess hydrating agents.	Not generally commercially available (72).
Reviscometer <sup>®</sup> (73)	Resonance running time	RVM600	Resonance running time is inversely related to skin stiffness (73).	Better able to discriminate between experimental treatments than cutometer. Measurements most sensitive on transverse forearm (73).	Sensitivity may differ depending on anatomic site (73).

Abbreviation: SWP, shear waves propagation.

**Appendix Table 6** Indirect Electrical Bioengineering Techniques

Technique	Developer/machines	Principles	Advantages	Disadvantages
Low-frequency impedance (frequency domain)	Clar, 1975 (74)	Impedance drops with increasing hydration. Frequency domain approaches examine the response of skin to sinusoidal stimulating frequencies.	Low frequencies give most informative data about physiological condition of skin overall because charge carriers can travel more time before field reverses (38).	Need liquid junction. Electrodes are occlusive. Long time needed for data collection (>20 min). Agents other than water can lower impedance. Measurements are quantitative rather than qualitative.
High-frequency impedance (3.5 MHz) (frequency domain)	Tregear, 1965	Impedance drops with increasing hydration. Impedance decreased with increasing frequency. Higher frequency, more skin penetration.	Provide information on deeper levels of skin. Can use dry electrodes.	Occludes site. Depth of SC not well defined. Agents other than water can affect readings. Pressure of probe and dermal irritants can influence readings. Cannot measure resistance and capacitance separately at high frequencies.
Impedance (capacitance calculated)	Nova DPM-9003 (Dermal Phase Meter)	Integrates selected measurements at varying frequencies of the applied alternating current. Capacitance is calculated from the signal phase delay using a proprietary chip. Final readout is in arbitrary units related to capacitance.	Good for assessing highly hydrated skin because of low variability of readings (75). Because of monofrequency approach, subject to less error, less confounding variables, and has increased sensitivity and specificity, (less false positives and false negatives) when compared with single-frequency machines, handling easy because of small dimensions and low weight.	Less sensitive for grading the dry state than the Corneometer (76). Agents other than water affect measurements.
Impedance (surface characterizing)	SCIM (ServoMed, Sweden)	Impedance is dependent on tissue hydration, composition and condition. SCIM measures impedance magnitude and phase at 31 frequencies to 5 selectable depths.	Uses the intrinsically more informative multifrequency approach, which is independent of changes in sweat gland activity, skin temperature, and confounding variables. Allows electrical impedance spectroscopy of selected layers.	Same disadvantages as with many electrical methods. Must use probe correctly (perpendicular, with correct pressure); wait 5 sec between repeating measurements on same site to avoid occlusion. Measurement failures with wet surface, dirt. Must perform measurements under appropriate ambient conditions (<22°C and >60% relative humidity).
Capacitance	Corneometer (Courage and Khazaka, Germany)	Capacitance increases with increasing hydration. The Corneometer uses variable frequencies in the low-frequency range (40–75 Hz); <75 dehydrated skin; 75–90 skin with tendency to dehydrate; >90 normal skin (arbitrary units) (12).	Easy to operate. Highly reproducible (12,75). Short measuring time (1 sec). Economical (75). Useful for extremely dry scaly skin. Information can be enhanced and nonhomogeneity of skin can be accounted for by using capacitance images, e.g., SkinChip (77).	Confined to measurement of variation in SC between initial and final states (12). Poor sensitivity to hydration process taking place in SC of normal skin because optimal range of water content in the SC for the capacitance method is much lower than for high-frequency conductance methods.

**Appendix Table 6** (Continued)

Technique	Developer/machines	Principles	Advantages	Disadvantages
Conductance	Skicon 100, 200 (Masuda, IBS Co., Ltd.)	Uses a fixed frequency (3.5 MHz) to measure conductance and capacitance separately.	Dry electrodes can be used. Correlates well with water content of superficial and deep SC layers. Suitable to assess the hydration dynamics of the SC induced in the skin. Not affected by electrolyte-rich solutions (78).	Single-frequency approach subject to more error, confounding variables, decreased sensitivity and specificity (increased false positives and false negatives) when compared with multifrequency machines (38). Current must propagate at least 5 mm to obtain reliable values.
High-frequency microwave (GHz)	Jacques, 1979 (79); Wavetek 1005	DPR (80) a percentage based on the probe's response to skin vs. a drop of water. A signal swept several MHz around a GHz resonates in a cable. Charged grid contacts skin, water absorbs energy and produces a standing wave shift, detection of which is adjusted to be linearly proportional to hydration level.	Detects quantitative differences. Rapid quantitation. Unaffected by topicals. SC probe depth varies. DPR basic unit is useful for comparisons.	DPR is not a true hydration percentage.
Millimeter wave reflectivity	Alekseev et al., 2008 (81)	Analysis of reflection of millimeter (mm) wavelength electromagnetic waves. Amount of reflection depends on electric property of skin (permittivity). Permittivity depends on free water content of skin. Free water content can be calculated from permittivity values using skin mode (81).	Good for measuring areas of thick stratum corneum such as palms in vivo.	Not so sensitive for areas of thin skin.

Note: The general advantages of these techniques are that they provide easy-to-measure, continuous data on skin hydration status and are readily available commercially.

Abbreviations: SCIM, surface-characterizing impedance monitor; DPR, dielectric probe response.

**Appendix Table 7** Bioengineering Techniques Based on Spectroscopy or Thermal Transfer

Technique	Developer/machines	Principles	Advantages	Disadvantages
Attenuated total reflectance Fourier-transformed infrared spectroscopy	1970s	Beam of polychromatic IR light is shone through a zinc or germanium selenide crystal applied to skin surface. Crystal creates 5–20 reflections, and absorption cycles between crystal and skin. Reflected beam is detected by spectrophotometer, Fourier transform of beam gives IR spectrum with bands of absorption in SC. Ratio of areas of amide I and II bands (peaks) provides relative SC water content. Amide I at 1645 cm <sup>-1</sup> is overlapped by band of protein-associated water, and thus will change with protein water content, whereas amide II at 1545 cm <sup>-1</sup> is not influenced by water (12).	In vivo, direct measurement of water. Quantitative, theoretical relationship between measured parameter and water concentration understood.	Expensive. Need signal averaging during time when site is occluded, since water content changes during measurements. Depth of penetration can vary with parameters. Bands from interfering substances could obscure amide bands. IR beam is weak (5–20 μm) penetrator. Data only pertain to superficial SC.
MRS/nuclear magnetic resonance spectroscopy	Foreman, 1970s, in vitro (82); Cuono, 1988, in vitro; Klein, 1988, in vitro; Zemtsov, 1989, in vivo;	Same principles as MRI apply except that the magnetic resonance signal is used to construct a magnetic resonance spectroscopic spectrum. MRS spectra can be obtained from protons as well as <sup>13</sup> C or <sup>31</sup> P. <sup>31</sup> P provides information about intercellular pH, tissue turnover rate and tissue bioenergetics (ATP, Pi, phosphocreatine).	Gives information about presence of chemical species as well as environment in which these materials exist and how this is changing over time. Quantifies hydration in both epidermis and superficial dermis. Metabolic, functional and structural information is possible. May be able to quantify specific tissue composition of hemoglobin, melanin, elastin. More precise and reproducible than capacitance or TTT. One of the few direct methods. Considered a reference technique.	Still experimental. Expensive. Limited availability. MRI images prone to motion artifacts. Underlying tissue may cause data contamination. Not portable. Heavy measuring apparatus limits measurement to forearms only.
NIR	Putnam, 1972 (83); Osberghaus, 1978 (84); Rigal, 1992 (85) NIRS5000 Spectrophotometer	NIR penetrates deep into skin. Two absorption bands are used at 1100 nm (minimal skin absorbance) and 1936 nm (strong absorption band by water molecules). The difference in absorbance at the two wavelengths is well correlated to clinical scores for skin dryness.	Gives information on molecular constitution of skin. Measures stratum corneum, epidermal and dermal water. Under certain conditions, exact quantitative relationship between IR absorption and water concentration in the stratum corneum (67). Can be used in clinical studies with the fiber-optic probe (Smartprobe™) to calculate changes in %RH (86). Permits avoidance of chemometric manipulation in data analysis (needed in most other techniques used). Direct correlation with visual dryness assessment scores. Had better linear regression for %RH scores when compared with conductance and visual dryness scores (86).	Topical agents may introduce error. Complicated and costly. Abrupt relative humidity variations may introduce error.

<p>Multiphoton laser tomography</p>	<p>Dermalinspect® Konig, 2003 (87)</p>	<p>Femtosecond near infrared laser scanning system based on two-photon excited fluorescence. Nonlinear induced autofluorescence comes from endogenous fluorophores such as NAD(P)H, flavins, elastin, porphyrin and melanin. Addition of second harmonic generation can be used to detect collagen. Fluorescence lifetime imaging allows 4-D imaging (3 dimensions plus time) (88).</p>	<p>Noninvasive, ultrahigh subcellular resolution up to 200 µm. Compact. More consistent results than cutometer and reviscometer (89).</p>	<p>Expensive.</p>
<p>Photoacoustic spectroscopy</p>	<p>Rosencwaig, 1977 (90); Campbell, 1979; Simon, 1981</p>	<p>Skin is exposed to IR radiation (heat). Depth of penetration of a periodic heat wave into a solid depends on its frequency. Radiation is absorbed by water in the SC at that depth. The superposition of thermal waves causes periodic temperature/pressure fluctuations at the surface of the skin, which can be detected as sound by a microphone in a closed photoacoustic cell. Signal produced depends on both optical and thermal properties of a sample.</p>	<p>Can quantitatively measure in vivo, and no contact needed between probe and skin. Good for investigation of the horny layer (91). One of the most depth-sensitive methods.</p>	<p>Not readily available. More technical developments needed.</p>
<p>Optothermal infrared spectrometry</p>	<p>Frodin, 1988 (92)</p>	<p>Technique derived from photoacoustic spectroscopy, based on detection of heat generated in a sample due to absorption of periodic monochromatic radiation with a wavelength of 1940 nm, a specific absorption band for water. The heat is conducted to a sapphire plate in contact with the skin and transparent to the radiation directed to the test area. The plate expands and is transformed to an electrical signal by an annular piezoelectric crystal cemented to the plate's edge.</p>	<p>By varying the chopper frequency, possible to measure at different thicknesses of the stratum corneum.</p>	<p>Not possible to determine absolute values for skin water content.</p>
<p>TTT</p>	<p>Soumet, 1986 (93) Hydrascan (Laboratoire Dermscan, France)</p>	<p>TTT is the property of one body exchanging heat with another when they are in contact. The skin temperature is measured. A stimulator then generates a thermal pulse that propagates through the epidermis to be picked up by a sensor. The difference in temperature is proportional to water content. The signal is analyzed and processed with electronic and data processing equipment. A series of three successive thermal pulses from 3 increasing powers provides hydration measurements from 3 epidermal depths.</p>	<p>Precise measurements at different depths is possible. Explores deeper depths than capacitance. small sensor size allows measurements on lips, eyes, nails which are not possible with either capacitance or MRI.</p>	<p>In vivo repeatability coefficient of variation is not as good as MRI but better than capacitance. Analytic variability is not as good as capacitance or MRI. Indirect technique. Slow data acquisition because requires a minimum of 10 min/depth measured.</p>

Abbreviations: TTT, transient thermal transfer; NIS, near infrared spectroscopy; MRS, magnetic resonance spectroscopy; %RH, percent relative humidity.

**Appendix Table 8** Bioengineering Techniques to Measure TEWL

Machine/developer	Principles	Advantages	Disadvantages
Evaporimeter (ServoMed, Sweden)	Probe with two pairs of humidity transducers and thermistor measures the partial water vapor pressure at 2 points (3 and 6 mm) above skin. Rate of evaporation ( $\text{g}/\text{m}^2/\text{hr}$ ) calculated from difference in partial water vapor pressure between these points. Probe has surface area $1.13 \text{ cm}^2$ . Normal TEWL $2\text{--}5 \text{ g}/\text{m}^2/\text{hr}$ .	Can evaluate products whose mode of action is occlusion. Accurate. Convenient to use. Inexpensive to operate (8).	Strictly speaking, does not measure skin hydration. Many factors can affect measurements, and they need careful monitoring. Evaporimeter may underestimate water evaporation rate at high TEWL (94).
Tewameter (Courage+Khazaka Electronic, Germany)	Same principle of measurement as Evaporimeter except sensors are at 3 and 8 mm above skin, and probe has surface area of $0.79 \text{ cm}^2$ .	More recent design. Measures probe temperature and graphs TEWL over time. More complete, somewhat more convenient, less sensitive to air turbulence than Evaporimeter (94).	Strictly speaking, does not measure skin hydration. Many factors can affect measurements, and they need careful monitoring. Newer instrument, so less well studied.
Derma Lab <sup>®</sup> System with TEWL and computerized evaporimetry. Cortex Technology, Denmark, 1999 (95)	Similar to Servomed Evaporimeter. Probe is open cylinder placed perpendicular to skin site. Sensors at fixed distances. Can be stand alone or equipped with personal computer interface.	Convenient monitoring of evaporative loss rates in real time, so any undesirable influences due to air currents and probe movements are readily apparent and their impact on measurements is instantaneously determined as well as retrospectively analyzed. Increased reproducibility and sensitivity.	Possible additional increased expense and complexity.
VapoMeter (Delfin Technology Ltd., Finland) (96)	Uses unventilated chamber method of measurement.	Closed chamber technology allows more mobile, flexible use of instrument. Less vulnerable to external air movements. Self-contained battery powered.	Problems with water vapor accumulation as with all closed chamber techniques.
Aquaflux (Biox Systems Ltd., U.K.) (96)	Uses condenser-chamber method of measurement.	Closed chamber technology allows more mobile, flexible use of instrument. Less vulnerable to external air movements. Bench top. Sensors protected from contamination and can maintain measurement geometry.	Problems with water vapor accumulation as with all closed chamber techniques. Somewhat less mobile than Vapometer.

Abbreviation: TEWL, transepidermal water loss.

Source: From Ref. 108.

**Appendix Table 9** Bioengineering Techniques to Image Stratum Corneum

Technique	Developer/machines	Principles	Advantages	Disadvantages
High-frequency (20 mHz) ultrasound, A mode	Alexander, 1979; Muller, 1985; Machines: DUB20 (Taberna Pro Medicum, Germany); Dermascan C (Cortex Technology, Denmark) (97)	A (amplitude) mode can measure the thickness of the skin layers. Adaptations to skin need a strongly dampened high-frequency ultrasound detector with very short impulses produced by ceramic or piezoelectric polymer transducers to detect as many echoes generated from as many interfaces as possible. The receptors made up of a device protecting against emitter overcharge, a wide-band radiofrequency amplifier, and a detector of radiofrequency signals. Signals are viewed on an oscilloscope.	Good for whole-skin visualization. Can differentiate epidermis from dermis in some cases. Can follow aging, sunlight damage, scleroderma, steroid atrophy.	Difficult to measure water quantitatively from images. Motion creates artifacts. Encoding process can distort space. Difficult to visualize very thin sites.
High-frequency (20 mHz) ultrasound, B mode	DUB20 (Taberna Pro Medicum, Germany); Dermascan C (Cortex Technology, Denmark) (97)	In B (brightness) mode, a succession of signal lines in A mode is acquired and reconstructed into a 2-D image. B scans are oriented in the x or y direction.	Useful to measure thickness and depth of skin cancers. Appearance of nonechogenic band in upper dermis may be more sensitive marker of aging than skin thickness. Distinguishes skin irritation vs. allergic reactions. Ultrasound waves theoretically carry information on elastic properties.	Difficult to measure water quantitatively from images. Motion creates artifacts. Encoding process can distort space. Information on how ultrasound waves carry information on skin elastic properties cannot yet be interpreted. More research needed.
High-resolution MRI	Hyde, 1987 (98); Querleux, 1988 (99); Bittoun, 1990 (100) (Skin Imaging Modele, France)	Conventional MRI equipment adapted to reduce field of view and pixel size using surface coils. Small surface radiofrequency coil to improve the signal-to-noise ratio. Bittoun made further advances by using the device with a 1.5-T system, obtaining very high-resolution images of normal skin as well as calculations of $T_1$ and $T_2$ (100).	More adapted to visualization of whole skin. Epidermis can be clearly delineated and analyzed to an axial spatial resolution of 35–70 $\mu\text{m}$ . Able to measure water directly and quantitatively in vivo. Can study proton exchange phenomenon. Repeated measurements over time in vivo.	Errors introduced by very short $T_2$ , chemical shift, and partial volume effect can overestimate epidermal thickness. Artifacts also caused by motion and spatial distortions introduced by encoding. Clinical utility limited by high cost, cumbersome equipment.

Abbreviation: MRI, magnetic resonance imaging.



**Appendix Table 10** Optical Techniques for Characterization of Skin Properties

Technique	Machines/developer	Principles	Advantages	Disadvantages
In vivo confocal microscopy/ CSLM	Petran, 1968; Corcuff, 1993 (101); Tandem Scanning microscope, (Tracor Northern)	A focused spot of light scans the sample. Reflected light in focal plane passes through a pinhole in front of a photomultiplier/TV camera detector. Images received are perfectly focused because almost all of the reflected light from above and below the plane in focus is blocked. The Nipkow disk has two thousand pinholes arranged in Archimede spirals, and allows lightening spot scanning and reflected light formation, which can be collected by a TV camera. After computer processing, a volume representation can be obtained.	Excellent axial (spatial) resolution (1 $\mu\text{m}$ ). Makes horizontal optical sections. Very good at visualizing SC. Preserves natural tonicity of skin, hydration of cells, and contrast of structures. Possible to measure SC thickness in vivo. Sharp focused. Allows study for first time of previously elusive stratum lucidum and stratum granulosum. Can visualize RBC in capillaries. Excellent reproducibility. Can work in 4-D space (volume and time) at the microscopic level noninvasively.	Artifacts caused by motion and spatial distortions introduced by encoding. Present section thickness that can be imaged is limited to 150 $\mu\text{m}$ . Still needs optical improvements to increase signal-to-noise ratio on images of inner epidermis. Optical sectioning is limited by transparency of tissue, scattering and absorption of light in the sample, working distance, and numerical aperture of the sample (101).
In vivo fiber-optic fluorescence laser scanning microscopy	Stratum <sup>®</sup> Suihko, 2005 (102)	Confocal microscope adapted for study of skin and mucous membranes using fiber optics and fluorophores. Light source is a 488 laser. Fluorescein sodium used as the fluorophore (intradermal injection or topical skin application) (102).	Flexible handheld system can be used on any site including mucous membranes. Fluorescein sodium is safe for use in vivo. Magnification 1000 $\times$ . Produces horizontal (en face) images. Cellular and some subcellular resolution is possible (102). Good for kinetic studies of substances applied on or into epidermis (103).	Same as CSLM. Intradermal injection of fluorophore requires some skill.
In vivo confocal Raman microspectroscopy	Caspers, 1998, 2001 (104,105)	In vivo optical method based on inelastic light scatter rather than absorption (vibrational spectroscopy). Skin Raman spectrum is measured. Signal is analyzed to extract information.	Depth resolution of 5 $\mu\text{m}$ . Able to measure concentration profiles. Quantitatively and qualitatively accurate when compared with gold standard X-ray microanalysis. Only in vivo method to analyze skin molecular composition as a function of distance to skin surface with similar detail and resolution. Better resolution than MRI or high-resolution ultrasound. Resolution to cellular level = 10–15 $\mu\text{m}$ . Maximum imaging depth is 1.2–2 mm. Lateral resolution is 15 $\mu\text{m}$ . Real-time imaging. Fiber-optic systems allow better access to normally difficult to access areas of skin. Noninvasive, so allows monitoring of inflammation over time. Can objectively monitor treatment effect.	Expensive, limited availability.
In vivo OCT (106,107)	Fercher, 1988 (108); Huang, 1991 (109)	Technique based on the Michelson principle of interferometry. OCT uses light in the near infrared range. Gel interface couples probe to skin. Light source emits a broad band light into fiber. Coupler directs one portion into reference arm. Diverging light beams are relayed via both objectives to the skin probe and reflecting mirror. Detector signals are converted from optical to electrical signals. Thickness measurements are calculated using software.	Resolution of distance to skin surface with similar detail and resolution. Better resolution than MRI or high-resolution ultrasound. Resolution to cellular level = 10–15 $\mu\text{m}$ . Maximum imaging depth is 1.2–2 mm. Lateral resolution is 15 $\mu\text{m}$ . Real-time imaging. Fiber-optic systems allow better access to normally difficult to access areas of skin. Noninvasive, so allows monitoring of inflammation over time. Can objectively monitor treatment effect.	Expensive. Limited availability. Not good enough resolution to judge grade of melanocytic tumors. Axial and lateral resolution is inferior to CSLM. Allows visualization of architectural changes but not single cells. Only able to image stratum corneum on palms and soles due to increased thickness.

Ellipsometry	Jasperson, 1969 (110)	<p>Monochromatic light passes through a plane polarizer oriented at 45° with respect to the incidence plane. Polarizer output is fed into a photoelastic modulator composed of a piezoelectric crystal oscillating at a particular frequency. Output of the modulator passes through collimator side of ellipsometer to skin of interest. Reflected light goes to telescopic side of spectrometer and is directed through a second polarizer to a PMT. PMT output and reference signal enter a lock-in amplifier, which gives intensity readings for the ellipsometric parameters. A computer program calculates the refractive index. Measures Refractive index.</p>	Changes in refractive index can be used to monitor hydration status and effect of moisturizers.	Topical agents may cause a change in reflectivity. Very indirect method.
Skin critical surface tension	Jacobi, 1949; Schneider, 1951; Ginn, 1968; El Khyat, 1996 (111)	<p>Droplets of standard liquids applied to skin and viewed under microscope. Critical surface tension can be calculated using Zisman technique. Also can measure wettability.</p>	Can quantify surface energy phenomenon resulting from sweat, serum, and emulsion application as well as interactions. Can quantify wettability.	Requires some skill on the part of the operator.

Abbreviations: OCT, optical coherence tomography; CSLM, confocal scanning laser microscopy; PMT, photomultiplier tube.

## REFERENCES FOR APPENDICES

1. Katz HI, Lindholm JS. In: Serup J, Jemec GBE, eds. *Handbook of Non-Invasive Methods and the Skin*. Boca Raton: CRC Press, 1995:49–55.
2. Kadner H, Bieshold C. *Dermatol Monatsschr* 1971; 157:758–759.
3. Marks R, Pearse AD. *Br J Dermatol* 1975; 92:651–657.
4. Ishida T, Kashibuchi M, Morita K, et al. *Cosmet Toiletries* 1979; 94:39–47.
5. Makki S, Barbenel JC, Agache P. *Acta Derm Venereol (Stockh)* 1979; 59:285–291.
6. Aubert L, Brun A, Grollier JF, et al. *Cosmet Technol Sci* 1982; 3:365–370.
7. Connemann BJ, Busche H, Kreuzsch J, et al. *Skin Res Technol* 1996; 2:40–48.
8. Marks R. In: Frost P, Horwitz SN, eds. *Principles of Cosmetics for the Dermatologist*. St Louis: CV Mosby, 1982:50–58.
9. Corcuff P, de Rigal J, Leveque JL. *Bioeng Skin* 1981; 4:16–31.
10. Barton SP, Marshall RJ, Marks R. *Bioeng Skin* 1987; 3:93–107.
11. Gormley DE. *Proceedings of Bioengineering and the Skin, San Francisco Meeting, September 1985*.
12. Black D, Diridollou S, Lagarde JM, et al. In: Baran R, Maibach HI, eds. *Cosmetic Dermatology*. 2nd ed. London: Martin Dunitz, 1998:125–150.
13. Altmeyer P, Erbler H, Kromer T, et al. *Acta Derm Venereol* 1995; 75:193–197.
14. Lagarde JM, Rouvrais C, Black D, et al. *Skin Res Technol* 2001; 7:112–121.
15. De Paepe K, Lagarde JM, Gall Y, et al. *Arch Skin Res* 2000; 10:500–510.
16. Picton W, Devitt H, Forgie MA. *Br J Dermatol* 1976; 95:341–348.
17. Taylor CJ, Brunt JN, Dixon RN, et al. *Pract Metallogr* 1978; 8:433.
18. Marshall R, Marks R. *Assessment of skin surface by scanning densitometry of macrophotography*. *Clin Exp Dermatol* 1983; 8:121–127.
19. Wolf J. *Z Mikrosk Anat Forsch* 1936; 46:170.
20. Jenkins HL, Tresise JA. *J Soc Cosmet Chem* 1969; 20:1.
21. De Paepe K, Janssens K, Hachem JP, et al. *Skin Res Technol* 2001; 7:184–192.
22. Miller DL. In: Serup J, Jemec GBE, eds. *Handbook of Non-Invasive Methods and the Skin*. Boca Raton: CRC Press, 1995:149–151.
23. Marks R, Dawber RPR. *Br J Dermatol* 1971; 84:117–123.
24. Serup J, Winther A, Blichmann C. *Clin Exp Dermatol* 1989; 14:277–282.
25. Schatz H, Kligman AM, Manning S, et al. *J Soc Cosmet Chem* 1993; 47:53–63.
26. Wilhelm KP, Kaspar K, Schumann F, et al. *Skin Res Technol* 2002; 8:98–105.
27. Pierard GE, Pierard-Franchimont C, Saint-Leger D, et al. *J Soc Cosmet Chem* 1992; 44:297–305.
28. Kligman AM, Schatz H, Manning S, et al. In: Frosch PJ, Kligman AM, eds. *Noninvasive Methods for the Quantification of Skin Functions*. New York: Springer-Verlag, 1993:309–316.
29. Thacker JG, Iachetta FA, Allaire FA, et al. *Rev Sci Instrum* 1977; 48:181.
30. Gunner CW, Williams EW, Greaves M, et al. In: Marks R, Payne PA, eds. *Bioengineering and the Skin*. Boston: MTP Press Limited, 1981:31–43.
31. Christensen MS, Hargens CW, Nacht S, et al. *J Invest Derm* 1977; 69:282–286.
32. Matts PJ, Goodyer E. *J Cosmet Sci* 1998; 49:321.
33. Matts PJ. In: Elsner P, Berardesca E, Wilhelm KP, et al. eds. *Bioengineering of the Skin: Skin Biomechanics*. Boca Raton: CRC Press, 2002:99–109.
34. Vlasblom DC. *Skin elasticity*. PhD thesis, University of Utrecht, 1967.
35. Salter DC. In: Elsner P, Berardesca E, Maibach HI, eds. *Bioengineering of the Skin: Water and the Statum Corneum*. Boca Raton: CRC Press, 1994: 205–216.
36. Barbenel JC, Evans JH. *J Invest Dermatol* 1977; 69:318–320.
37. Lévêque JL. In: Baran R, Maibach HI, eds. *Cosmetic Dermatology*. 2nd ed. London: Martin Dunitz, 1998:537–544.
38. Salter DC. In: Elsner P, Berardesca E, Maibach HI, eds. *Bioengineering of the Skin: Water and the Stratum Corneum*. Boca Raton: CRC Press, 1994:205–216.
39. Franke EK. *J Appl Physiol* 1950; 3:582.
40. Von Gierke HE, Oestreicher HI, Franke EK, et al. *J Appl Physiol* 1952; 4:886.
41. Hashmi F, Malone-Lee J. *Skin Res Technol* 2007; 13:252–258.
42. Zhang Y, Brodell RT, Mostow EN, et al. *Skin Res Technol* 2009; 15:271–282.
43. Grahame R. *Clin Sci* 1970; 39:223–238.
44. Serup J, Northeved A. *J Dermatol* 1985; 12:52–62.
45. Serup J. In: Elsner P, Berardesca E, Wilhelm KP, et al., eds. *Bioengineering of the Skin: Skin Biomechanics*. Boca Raton: CRC Press, 2002:117–121.
46. Jemec GBE, Jemec B, Jemec BIE, et al. *Plast Reconstruct Surg* 1990; 85:100–103.
47. Gniadecka M, Serup J. In: Serup J, Jemec GBE, eds. *Handbook of Non-Invasive Methods and the Skin*. Boca Raton: CRC Press, 1995:329–334.
48. Hauselmann HJ, Renfer K, Seifert B, et al. *Curr Probl Dermatol* 1998; 26:134–144.
49. Hauselmann HJ, Huber K, Seifert B, et al. In: Elsner P, Berardesca E, Wilhelm KP, et al., eds. *Bioengineering of the Skin: Skin Biomechanics*. Boca Raton: CRC Press, 2002:123–138.
50. Dikstein S, Hartzshtark A. In: Marks R, Payne PA, eds. *Bioengineering and the Skin*. Boston: MTP Press, 1981:45–53.
51. Gartstein V, Elsau WH. *Proceeding of the 8th International Symposium on Bioengineering and the Skin, Stresa, 1990:70*.
52. Pierard GE. *Bioeng Skin Newsl* 1980; 2:31.
53. Manny-Aframian V, Dikstein S. In: Serup J, Jemec GBE, eds. *Handbook of Non-Invasive Methods and the Skin*. Boca Raton: CRC Press, 1995:345–347.
54. Hargens CW. In: Serup J, Jemec GBE, eds. *Handbook of Non-Invasive Methods and the Skin*. Boca Raton: CRC Press, 1995:359–366.
55. Tosti A, Compagno G, Fazzini ML, et al. *J Invest Dermatol* 1977; 69:315–317.
56. Pugliese PT, Potts JR. In: Elsner P, Berardesca E, Wilhelm KP, et al., eds. *Bioengineering of the Skin: Skin Biomechanics*. Boca Raton: CRC Press, 2002:147–159.
57. Manny-Aframian V, Dikstein S. In: Serup J, Jemec GBE, eds. *Handbook of Non-Invasive Methods and the Skin*. Boca Raton: CRC Press, 1995:349–352.
58. Wilhelm KP, Cua AB, Maibach HI. In: Frosch PJ, Kligman AM, eds. *Non-Invasive Methods for the Quantification of Skin Functions*. New York: Springer-Verlag, 1993:191–203.
59. Nacht S, Close JA, Yeung D, Gans EG. *J Soc Cosmet Chem* 1981; 32:55–65.
60. Prall JK. *J Soc Cosmet Chem* 1973; 24:693.
61. Falanga V, Bucalo B. *J Am Acad Dermatol* 1993; 29:47.
62. Romanelli M, Falanga V. In: Elsner P, Berardesca E, Wilhelm KP, et al., eds. *Bioengineering of the Skin: Skin Biomechanics*. Boca Raton: CRC Press, 2002:139–145.
63. Guibarra E, Nicholls S, Marks R. *Bioengin Skin Newsl* 1979; 2:29.
64. Graves CJ, Edwards C. In: Elsner P, Berardesca E, Wilhelm KP, et al., eds. *Bioengineering of the Skin: Skin Biomechanics*. Boca Raton: CRC Press, 2002:161–178.
65. Torgalkar AM. In: Marks R, Payne PA, eds. *Bioengineering and the Skin*. Boston: MTP Press, 1981:55–65.
66. Tronnier H, Wagener HH. *Dermatologica* 1952; 104:135–151.
67. Potts RO, Christman DA, Buras EM. *J Biomech* 1983; 16:362–372.
68. Sarvazyan AP, Ponomarjev VP, Vucelic D, et al. *Method and device for acoustic testing of elasticity in biological tissues*. U.S. Patent 1990, No. 4, 947, 851.
69. Vexler A, Polyansky I, Gorodetsky R. *J Invest Dermatol* 1999; 113:732–739.

70. Sakai S, Shu S, Endo Y, et al. *Skin Res Technol* 2000; 6:128–134.
71. Sasai S, Zhen YX, Suetake T, et al. *Skin Res Technol* 1999; 5: 237–246.
72. Marks R. In: Frost P, Horwitz SN, eds. *Principles of Cosmetics for the Dermatologist*. St Louis, MO: CV Mosby, 1982: 50–58.
73. Paye M, Mac-Mary S, Elkhyat A, et al. *Skin Res Technol* 2007; 13:343–349.
74. Clar E, Her CP, Sturelle CG. *J Soc Cosmet Chem* 1975; 26:337–353.
75. Distant F, Berardesca E. In: Berardesca E, Elsner P, Wilhelm KP, et al., eds. *Bioengineering of the Skin: Methods and Instrumentation*. Boca Raton: CRC Press, 1995:5–12.
76. Gabard B, Treffel P. In: Elsner P, Berardesca E, Maibach HI, eds. *Bioengineering of the Skin: Water and the Stratum Corneum*. Boca Raton: CRC Press, 1994:147–170.
77. Batisse D, Giron F, Leveque JL. *Skin Res Technol* 2006; 12:99–104.
78. Tagami H. In: Elsner P, Berardesca E, Maibach HI, eds. *Bioengineering of the Skin: Water and the Stratum Corneum*. Boca Raton: CRC Press, 1994:59.
79. Jacques SL. *IEEE Eng Med Bio Soc Conf* 1979; 180–182.
80. Jacques SL. A linear measurement of the water content of the stratum corneum of human skin using a microwave probe. 32nd Annual Conference on Engineering in Medicine and Biology, Denver, CO, 1979.
81. Alekseev SI, Szabo I, Ziskin MC. *Skin Res Technol* 2008; 14: 390–396.
82. Foreman MI. *Biochim Biophys Acta* 1976; 437:599–603.
83. Putnam NA. *J Soc Cosmet Chem* 1972; 23:209–226.
84. Osberghaus R, Glohuber C, van Raay HG. *J Soc Cosmet Chem* 1978; 29:133–146.
85. Rigal J, Losch MJ, Bazin R, et al. *IFSCC Int Congr Yokohama* 1992; 3:1131–1146.
86. Kilpatrick-Liverman L, Kazmi P, Wolff E, et al. *Skin Res Technol* 2006; 12:162–169.
87. Konig K, Riemann I. High resolution multiphoton tomography of human skin with subcellular spatial resolution and picosecond time resolution. *J Biomed Opt* 2003; 8:432–439.
88. Kobow J, Harzic RL, Martin S, et al. *DermaInspect<sup>®</sup>: in vivo high resolution multiphoton tomography of human skin*. 18 August, 2009. Available at: [http://www.focuseonmicroscopy.org/2005/PDF/022\\_Kobow.pdf](http://www.focuseonmicroscopy.org/2005/PDF/022_Kobow.pdf).
89. Koehler MJ, Preller A, Kindler N, et al. *Skin Res Technol* 2009; 15:357–363.
90. Rosencwaig A, Pines E. *J Invest Dermatol* 1977; 69:296–298.
91. Kolmel K, Nicolaus A, Giese K. *Bioeng Skin* 1985; 1:125–131.
92. Frodin T, Helander P, Molin L, et al. *Bioeng Skin* 1988; 4:115–130.
93. Soumet JL, Dittmar A, Leftheriotis G. *Int J Microcirc* 1986; 5:73–83.
94. Barel AO, Clarys P. In: Serup J, Jemec GBE, eds. *Handbook of Non-Invasive Methods and the Skin*. Boca Raton: CRC Press, 1995:179–195.
95. Grove GL, Grove MJ, Zerweck C, et al. *Skin Res Technol* 1999; 5:1–8.
96. Imhof RE, Xiao P, De Jesus MEP, et al. New developments in skin barrier measurements. In: Rawlings AV, Leyden JJ, eds. *Skin Moisturization*. London: Informa Health Care, 2009:463–479.
97. El-Gammal S, Auer T, Hoffmann K, et al. In: Frosch PJ, Kligman AM, eds. *Non-Invasive Methods for the Quantification of Skin Functions*. New York: Springer-Verlag, 1993:104–129.
98. Hyde JS, Tesmanowicz H, Kneeland BJ. *Magn Reson Med* 1987; 5:449–461.
99. Querleux B, Yassine MM, Darrasse L, et al. *Bioeng Skin* 1988; 4:1–14.
100. Bittoun J, Saint-James H, Querleux BG. *Radiology* 1990; 176: 457–460.
101. Corcuff P, Lévêque JL. *Dermatology* 1993; 186:50–54.
102. Suihko C, Swindle LD, Thomas SG, et al. *Skin Res Technol* 2005; 11:254–267.
103. Lademan J, Otberg N, Richter H, et al. *Skin Res Technol* 2007; 13:119–132.
104. Caspers PJ, Lucassen GW, Wolthuis R, et al. *Biospectroscopy* 1998; 4:531–539.
105. Caspers PJ, Lucassen GW, Carter EA, et al. *J Invest Dermatol* 2001; 116:434–443.
106. Gladkova ND, Petrova GA, Nikulin NK, et al. *Skin Res Technol* 2000; 6:6–16.
107. Pagnoni A, Knuettel A, Welker P, et al. *Skin Res Technol* 1999; 5:83–87.
108. Fercher AF, Mengedoht K, Werner W. *Opt Lett* 1988; 13:186–188.
109. Huang D, Swanson EA, Lin CP, et al. *Science* 1991; 254: 1178–1181.
110. Jaspersen SN, Schatterly SE. *Rev Sci Instrum* 1969; 40:761.
111. El Khyat A, Mavon A, Leduc M, et al. *Skin Res Technol* 1996; 2:91–96.
112. Thompson DE, Hussein HMG, Perritt RQ. In: Marks R, Payne PA, eds. *Bioengineering and the Skin*. Boston: MTP Press, 1981:103–113.
113. Gunner CW, Hutton WC, Burlin TE. *Med Biol Eng Comput* 1979; 17:142.
114. Girard P, Beraud A, Sirvent A. *Skin Res Technol* 2000; 6:205–213.
115. Welzel J. *Skin Res Technol* 2001; 7:1–9.
116. Lee HK, Seo YK, Baek JH, et al. *Skin Res Technol* 2007; 14:8–12.



# Index

- AA. *See* Azelaic acid (AA)  
ABA. *See* Aldobionic acids (ABA)  
ABCA12 gene, 155  
Abrasive nail files, 250  
ABS. *See* Acrylonitrile butadiene styrene (ABS)  
Absorbent gel materials (AGM), 55  
Acai berry, 183  
Acetone, 262, 263  
Acetoxyacids, antagonistic, 101  
N-acetylamino acids, 101–103  
Acetylcholine, 6  
Acetylcholinesterase (AChE), 52  
N-Acetyl compounds, 101–103  
N-Acetylcysteine  
  photoprotective effects of, 119  
N-Acetyl-5-methoxytryptamine  
  photoprotective effects of, 119  
N-Acetyl-4-S-cystalminylphenol  
  as depigmenting agent, 312  
AChE. *See* Acetylcholinesterase (AChE)  
Acid-based primer, 262  
Acids neutralization, 488–489  
Acid strength, of hydroxyacids, 94  
Acne, 156, 180  
  cryosurgery of, 438  
  hydroxyacids and, 98  
  PDT and, 426–427  
  racial differences in, 381–382, 383  
  salicylic acid, 192  
  topical keratolytic agents for, 352–362  
    azelaic acid, 359–360  
    benzoyl peroxide, 352–353  
    glycolic acid, 361  
    in vivo potential of, 361–362  
    overview, 352  
    resorcinol, 361  
    retinoids, 353–359  
    salicylic acid, 360  
    sulfur, 360–361  
  treatment  
    azelaic acid, 185  
    comedolytic agents, 185  
    topical antibiotics, 185  
    topical tretinoin, 185  
Acneogenesis, 285  
Acne keloidalis, 390–391  
Acne scarring, in ethnic skin, 383  
Acne vulgaris, ATRA for, 124  
Acnic inflammatory lesions, improvement of, 136–137  
Acquired hypertrichosis lanuginosa, 305  
Acrodisc<sup>®</sup> Syringe Filters, 56  
2-Acrylamido-2-methylpropanesulfonate (AMPS), 272  
Acrylic acid, 261  
  polymers, 272  
Acrylic hydrogels, 371  
Acrylonitrile butadiene styrene (ABS), 259  
ACTH. *See* Adrenocorticotropic hormone (ACTH)  
Actinic keratosis (AK)  
  hydroxyacids for, 100  
  PDT and, 424–425  
  topical 5-FU for, 429–432  
    comparison of trials/methods, 429–430  
    0.5% 5-FU, 430  
    1% 5-FU, 430  
[Actinic keratosis (AK)  
  topical 5-FU for]  
  5% 5-FU, 430  
  history of, 429  
  limitations of, 432  
  side effects of, 430–432  
Action potential, 466  
Acyl CoA:retinol acyltransferase (ARAT), 106  
Adapalene  
  for acne, 358–359  
  as depigmenting agent, 313  
Adenine, structures of, 142  
Adenoside monophosphate disodium salt  
  as depigmenting agent, 313  
Adhesion scalp flaking (ASF), 232, 233  
Adhesion promoters, 259  
Adipocytes, 290  
  anisopoikilocytotic, 290  
  estrogen acts on, 290  
Adipokine, 290  
Adipose tissue, distribution of, 366  
ADPV. *See* Adsorption differential pulse voltammetry (ADPV)  
Adrenocorticotropic hormone (ACTH), 10  
Adsorption differential pulse voltammetry (ADPV), 47  
Africans, 386  
Age, 399  
  sensitive skin and, 75  
  spots, 135  
Age-related effacement, 456  
Age spot keratoses  
  hydroxyacids for, 100  
Aging, 123. *See also* Antiaging  
  barrier structure and function of, 14–16  
  clinical difference between, 43  
  cutaneous perfusion of, 22–25  
  dermal structure of, 16–22  
  dermal collagen, 16–18  
  dermal elastin, 18–20  
  GAG, 20–22  
  protein structure, 20–22  
  water, 20–22, 23  
  and estrogens, 407  
  hormonal, 405–406  
  HRT and, 406  
  hyaluronan and, 87  
  hydroxyacids for, 99  
  idebenone and, 111, 112  
  and isoflavones, 407  
  of men, 365–366  
  and menopause, 405  
  mitochondrial theory of, 111–112  
  and phytoestrogens, 407  
  racial differences and, 383–384  
  retinol and, 125  
AGM. *See* Absorbent gel materials (AGM)  
AHA. *See* A-hydroxyacids (AHA)  
AK. *See* Actinic keratosis (AK)  
Alcohol based styling polymers, 226  
Aldaric acid, 93  
Aldobionic acids (ABA), 93  
Aldonic acid, 92–93  
Aldose, 92  
Alduronic acid, 93  
Allergic contact dermatitis, 165–166  
  to fragrance ingredients, 166  
  geraniol, 169  
  irritant and, racial differences in, 382–381  
Allergic reactions, nails, 260–261  
Alloderm, 454  
All-trans retinoic acid (ATRA)  
  for acne vulgaris, 124  
  photoaging and, 123, 124  
  side effects of, 124  
Aloe vera, 176  
Alopecia  
  cryosurgery and, 441  
  and menopause, 408  
 $\alpha_2$ -Adrenoceptors, 5  
 $\alpha$ -hydroxyacids (AHA), 35, 91–92, 92, 152, 184, 192  
  alkyl, 91, 92  
  aralkyl, 91  
  for basal layer peeling, 484  
  EPS. *See* Easy Phytic Solution (EPS)  
  for exfoliation, 482  
  for intraepidermic peeling, 482–483  
  neutralization, 488–489  
  polycarboxy, 92  
  related compounds, 93  
 $\alpha$ -Lipoic acid, 196  
 $\alpha$ -Tocopherol, 115–116  
  photoprotective effects of, 118  
Aluminum salts, 197  
Ambras syndrome. *See* Universal congenital hypertrichosis  
Ambulatory phlebectomy, 299–300  
  history of, 294  
  for varicose veins, 299, 300  
Aminexil, 369  
Amino acids, hydroxyacids and, 94  
Ammonium hydroxide (NH<sub>4</sub>OH), 48  
AMPLI RF. *See* Automatic multifrequency and low impedance (AMPLI) RF  
AMPS. *See* 2-acrylamido-2-methylpropane-sulfonate (AMPS)  
Anatomic site  
  sensitive skin and, 77  
Ancillary skin care products. *See also* Skin care products  
  astringents, 192  
  earth-based masks, 194  
  epidermabrasion, 193–194  
  exfoliants, 192  
  face masks, 194  
  facial scrubs, 193  
  hydrocolloid masks, 194  
  rubber-based masks, 194  
  textured cloths, 193–194  
  vinyl masks, 194  
  wax masks, 194  
Androgenetic alopecia, 390  
  global assessment, 514–515  
  hair diameter  
    Diastron<sup>®</sup>, 514  
    hair weight, 514  
    linear density, 513  
    optical fiber diameter assessment, 514  
  phototrichogram, 513–514

- [Androgenetic alopecia]  
 hair regrowth, measurement of, 511  
 direct manual hair count, 512  
 fiberoptic microscopic hair count  
 method, 512  
 macrophotographic manual hair count, 512  
 TrichoScan<sup>®</sup>, 512–513  
 unit area trichogram, 513  
 therapies, 510  
 finasteride, 510–511  
 hair restoration, 511  
 minoxidil, 510–511  
 prostaglandin F2 alpha, 511  
 AN2690 (5-fluoro-1,3-dihydro-1-hydroxy-2,1-benzoxaborole), 64  
 Animal electricity. *See* Bioelectricity  
 Anionic emulsifiers, 272  
 Anisopoikilocytotic adipocytes, 290  
 Antiaging. *See also* Aging  
 bimineral complex for. *See* Photoaging,  
 bimineral complex for  
 idebenone and, 111  
 Antiandrogens, for hair removal, 307  
 Antidandruff actives, 235, 238  
 efficacy measure of, 238  
 Antidandruff products, 236  
 Antidandruff therapies  
 ciclopirox olamine, 238  
 coal tar, selenium sulfide, and PTZ, 238  
 ketoconazole *vs.* PTZ, 237  
 ketoconazole *vs.* selenium sulfide, 237–238  
 Antimicrobial activity, of bioelectricity, 476  
 Antioxidant capacity  
 vitamin E, 504  
 Antioxidants  
 defined, 94  
 effect of environmental stressors on,  
 117–118. *See also* Ozone; Ultraviolet  
 radiation (UVR)  
 enzymes, 115  
 effect of photoaging on, 117–118  
 hydroxyacids as, 94  
 interceptive, 116  
 network of, 115–117  
 nonenzymic, 116  
 effect of photoaging on, 117  
 oxidative stress and, 115  
 photoaging and, 100–101  
 repair, 116  
 respiratory chain  
 idebenone as, 112  
 topical, photoprotection by, 118–120  
 combination of, 120  
 polyphenols, 118–119  
 thiols, 119  
 vitamin C, 118  
 vitamin E ( $\alpha$ -tocopherol), 118  
 Antioxidant testing, 504  
 Antioxidative capacity, assess  
 photochemiluminescence device, 503  
 sample analysis, 503–504  
 Antioxidative capacity of lipid-soluble  
 (ACL), 503  
 Antiperspirants, 197  
 for men, 369  
 Antiwrinkle potential  
 medications, 178  
 Apoptosis, 422  
 Appearance restoration  
 fostering independence and, 332  
 goal directedness, 332  
 as healing modality, 339  
 intervening care, 330  
 intervening process, 333–334  
 mirroring tactics and, 331  
 philosophy of, 330–331  
 preparation and implementation, 333  
 [Appearance restoration]  
 process identification in, 333  
 sessions overview, 333  
 social recognition and, 331  
 social support and competence,  
 331–332  
 symbolism and, 331  
 therapeutic plan, 334–339  
 Aquamid<sup>®</sup>, 371  
 Aralkyl AHAs, 91  
 ARAT. *See* Acyl CoA:retinol acyltransferase  
 (ARAT)  
 Arbutin, 176  
 as depigmenting agent, 313  
 Areolar layer, 290  
 Artecoll<sup>®</sup>, 371  
 Arterial injection, 299  
 sclerotherapy and, 299  
 Artificial nails, 247, 259–260  
 adverse reactions of, 263–264  
 allergic reactions, 260–261  
 hardeners, 265–267  
 nonallergic reactions, 261–262  
 preformed, 263–264  
 decorative, 264  
 in gold plate, 264  
 removal of, 262  
 risks, 267  
 teflon templates for sculptured, 260  
 UV gels and, 262–263  
 colored, 263  
 removable, 263  
 removal of, 263  
 UV lights and, 261  
 ASA. *See* Ascorbic acid (ASA)  
 Ascorbic acid (ASA), 503  
 as depigmenting agent, 313  
 photoprotective effects of, 118  
 Asians, 386  
 Astringent formulations, 192  
 Asymmetric smile, botulinum toxin (BT)  
 for, 449  
 Atopic dermatitis, 155–156  
 ATRA. *See* All-trans retinoic acid (ATRA)  
 Autoclaves, 257  
 Automatic multifrequency and low  
 impedance (AMPLI) RF, 292  
 Azelaic acid (AA)  
 for acne, 359–360  
 as depigmenting agent, 312  
 and tretinoin, 314  
 Bacterial biofilms, 476  
*Baphicacanthus cusia*, 177  
 Barrier creams (BC), 47  
 data of, 50–51  
 in vitro and in vivo methods, 52  
 Barrier function  
 alterations, sensitive-skin and, 74  
 Basal cell carcinomas (BCC), 43  
 PDT and  
 nodular, 426  
 superficial, 425  
 Basal layer peeling, 483–484  
 Base coats, nails, 253  
 BBI. *See* Bowman-Birk inhibitor (BBI)  
 BC. *See* Barrier creams (BC)  
 BCC. *See* Basal cell carcinomas (BCC)  
 BCOP. *See* Bovine corneal opacity and  
 permeability test (BCOP)  
 Beard  
 skin problems related to, 367, 368  
 Beauty products  
 for men, 370  
 Becker nevus  
 treatment of, 321  
 Behind-the-knee (BTK) test  
 clinical in-use protocol, 55  
 lotion measurement, 55–56  
 overview, 54  
 protocol, 54–55  
 protocol for, 54–55  
 result of, 56–61  
 statistical analyses, 56  
 test products, 55  
 Bemotrizinol, 201  
 Benign prostatic hyperplasia (BPH), 511  
 Benzylidene malonate polysiloxane.  
*See* Parsol SLX  
 Benzophenones, 198  
 Benzoyl peroxide (BPO)  
 for acne, 352–353  
 in vivo keratolytic potential of, 361–362  
 treatment technology, 185  
 BHA. *See*  $\beta$ -hydroxyacids (BHA)  
 $\beta$ -hydroxyacids (BHA), 92, 184, 192, 196, 197  
 Bicheron's microcirculatory theory, 411  
 Bier spots, 311, 312  
 Bimineral complex. *See also* Biomimetic  
 electricity  
 and dermal extracellular matrix  
 production, 477  
 elemental, 477  
 for facial photoaging, 478–480  
 in vitro cytokine studies, 477  
 melanin and, 477–478  
 skin explants treatment with, 477  
 tolerability and efficacy, 478  
 topical application, 477  
 tyrosinase inhibition, 477  
 Bio-Aquamid<sup>®</sup>, 371  
 Biochemical action  
 of hydroxyacids, 97  
 Biochemistry  
 of hydroxyacids, 94  
 Bio-Electric Field Imager<sup>®</sup>, 468  
 Bioelectricity, 467–469. *See also* Biomimetic  
 electricity  
 antimicrobial activity, 476  
 cellular effects, 472–474  
 cell proliferation, 473–474  
 skin pigmentation, 473  
 scientific advances in, 469  
 skin wounds, 469–471  
 and tissue engineering, 475  
 and wound healing enhancement, 474–475  
 Bioengineering techniques, 530–531  
 electrical, 532–533  
 to image stratum corneum, 537  
 to measure desquamation, 525  
 to measure elasticity  
 parallel to skin, 526–527  
 perpendicular to skin surface, 528–529  
 to measure TEWL, 536  
 mechanical, 526–531  
 moisturizers efficacy, 522  
 for skin surface contour evaluation, 523–524  
 on spectroscopy/thermal transfer, 534–535  
 Biofilm bacteria, 476  
 Biological action  
 of hydroxyacids, 97, 98  
 Biomimetic electricity, 466. *See also* Bimineral  
 complex  
 anti-inflammatory activity, 477  
 clinical efficacy, 469  
 for skin antiaging, 478–480  
 clinical safety, 478  
 delivery system, 477  
 for dermal extracellular matrix production,  
 477  
 melanogenesis inhibition, 477–478  
 in tissue engineering, 475  
 tolerability, 478

- Bionic acid. *See* Aldobionic acids (ABA)
- Bisdisulizole disodium, 201
- Bisotrizole, 201
- Bleaching, 306  
hair, 220  
products, cosmetic use of, 314–315
- Blend method  
for hair removal, 307
- Blood flow volume (BFV), 505
- Blood vessel reactivity, of skin  
ethnic differences in, 398–399
- Blue hypermelanosis, 311
- Body hair  
ethnic differences in, 392–393
- Body lotion. *See* Hand and body lotions
- Body sweat distribution, 3
- Botox<sup>®</sup>, 442. *See also* Botulinum toxin (BT)  
for asymmetric smile, 449  
for bunny lines, 447  
for crow's feet lines, 446  
for décolleté wrinkles, 449  
delivery, 420  
for depressor angulis oris, 449  
dose recommendation for, 444  
for forehead lines, 446  
for gingival smile, 449  
for glabellar lines, 445  
for hyperhidrosis, 451  
for masseteric hypertrophy, 449  
for mentalis, 448  
for nasal tip droop, 447  
for platysmal bands, 449
- Botulinum toxin (BT), 242, 245, 246  
adjunctive, 449–450  
commercial preparations of, 442  
complications of, 451  
contraindications, 442, 444  
for décolleté wrinkles, 449  
doses, 444  
dose-equivalence of, 442  
for facial asymmetry, 446–447  
for lower face, 447–449  
for middle face, 447  
overview, 442  
reconstitution of, 442  
role of, 185  
side effects of, 451  
for upper face, 444–446
- Bovine collagen, 454, 456
- Bovine corneal opacity and permeability test (BCOP), 287
- Bowen disease  
PDT and, 426
- Bowman-Birk inhibitor (BBI), 128
- BPO. *See* Benzoyl peroxide (BPO)
- Brittle nail, 248
- Bronzing gels, 198
- Brown hypermelanosis, 311
- BT. *See* Botulinum toxin (BT)
- BTK. *See* Behind-the-knee (BTK) test
- Buffers, nail, 250  
padded chamois, 250
- Bunny lines, botulinum toxin (BT) for, 447
- Butylhydroxytoluene, 262
- Café Au Lait Macules  
treatment of, 321
- CaHA. *See* Calcium hydroxylapatite (CaHA)
- Calcium hydroxylapatite (CaHA), 371, 458–459  
injection techniques, 459
- Calf muscle pump, 295
- California Air Resources Board (CARB), 252
- Camellia sinensis*, 183  
as antioxidants, 119  
photoprotective effects of, 119
- Camphor, 252
- CAMVA. *See* Chorioallantoic membrane vascular assay (CAMVA)
- Canadian Hyperhidrosis Committee, 450–451
- Cancer chemoprevention, 203
- Candida*, 261
- Canthaxanthin, 198
- CAP. *See* Contact allergy patch (CAP)
- CARB. *See* California Air Resources Board (CARB)
- Carbohydrate metabolism  
hydroxyacids and, 94
- Carbon dioxide lasers, 496
- Carotenoids  
retinol and, 123
- Cationic emulsifiers, 272
- Caucasians, 386
- Causative ingredients  
diagnosis of, 166
- CCCA. *See* Central centrifugal cicatricial alopecia (CCCA)
- CD. *See* Contact dermatitis (CD)
- CD44, 86
- Cellar effects, of bioelectricity, 472–474  
cell proliferation, 473–474  
skin pigmentation, 473
- Cell membrane  
fluid mosaic model of, 154
- Cell proliferation, bioelectricity and, 473–474
- Cells  
Langerhans, 269
- Cellular necrosis, 422
- Cellular retinol-binding protein (CRBP), 123
- Cellulite  
aetiopathogenesis, 290–291  
development of, 290  
evaluation of, noninvasive techniques to, 291–293  
dermatology, 292  
laser Doppler flowmetry, 291  
magnetic resonance imaging, 292  
massage treatment, 292  
mesotherapy, 293  
optical devices, 292–293  
pharmacological agents, 292  
plicometry, 291–292  
surgical subcision, 293  
thermography, 291  
thigh circumference measurements, 291  
ultrasonography, 291  
overview of, 290  
stages of, 291
- Cellulosic polymers, 272
- Centella asiatica*, 292
- Central centrifugal cicatricial alopecia (CCCA), 389, 391
- Ceramides  
barrier function of, 157–158  
endogenous regulation of, 157–158  
on keratinocyte differentiation, 159  
overview, 150  
structure of, 150–154  
synthesis through delivery of ceramide precursors, 158–159  
topical application of human SC, 158
- Ceruloderma. *See* Blue hypermelanosis
- Chamomilla extracts  
as depigmenting agent, 313
- Cheekbones  
in men, 373
- Chemabrasion and peels  
for depigmentation, 315
- Chemical peeling. *See* Peelings
- Chorioallantoic membrane vascular assay (CAMVA), 287
- Chromated glycerin, 297
- Chromhidrosis  
treatment of, 323
- Chromophores, 43  
chemical reaction of, 115  
type I, 115  
type II, 115
- CI. *See* Color index number (CI)
- Cinoxate, 200
- CIR. *See* Cosmetic Ingredient Review Expert Panel (CIR)
- CIT. *See* Cumulative irritation test (CIT)
- Citrate cycle  
hydroxyacids and, 94
- Cleansing cloth  
facial foundation removal, 193
- Climateric keratoderma  
and menopause, 408
- Climateric syndrome, defined, 405
- Clostridium botulinum*, 442
- Coenzyme Q10, 111, 112  
aging and, 112  
*vs.* idebenone, 111, 112
- Coffea arabia*, 197
- Coffee berry  
aging and, 119
- Cognition enhancement  
idebenone and, 111
- Collagen(s), 371  
bovine, 454, 456  
density, of skin, 1  
human, 456  
porcine, 459
- Collagen fibers  
and wrinkles, 242, 243, 244
- Collagen production  
in total soy, 132
- Collagen synthesis, in heart tissue, 475  
microcurrent and, 475
- Color additives, nail, 252–253
- Colored UV gels, 263
- Colorimetric measurements, in elderly men, 9
- Colorimetric method, 238
- Color index number (CI), 253
- Color Me Beautiful*, 334
- Combination therapies, for depigmentation, 314
- Comedogenesis, 285–286
- Compression  
in sclerotherapy, 294
- Conditioners, for men, 368
- Conditioning hair, 223
- Confocal microscope, 181
- Confocal Raman spectroscopy (CRS), 278, 279
- Congenital generalized hypertrichosis, 305
- Contact allergy, 165–166
- Contact allergy patch (CAP), 49
- Contact dermatitis (CD), 47
- Contact urticaria, 262, 286–287
- Corneocyte variability, of skin  
ethnic differences in, 398
- Corneometer<sup>®</sup>, 32–33, 281
- Corneometer CM 825, 181
- Corneometer units (CU), 36
- Cosmeceuticals  
and additional antioxidants  
coffeeberry, 197  
grape seed extract, 197  
idebenone, 197  
oatmeal, 197  
olive oil, 197  
rosemary, 197  
tea tree oil, 197  
 $\alpha$ -hydroxyacids, 197  
antioxidants, 196–197  
antiperspirants, 197  
definition of, 196  
self-tanning lotions, 198  
sunscreens  
chemical sunblocks, 198  
Parsol 1789, 198



- [Cosmeceuticals  
sunscreens]  
physical sunblocks, 198  
UVA, 197
- Cosmetic allergy, 170
- Cosmetic cryosurgery. *See* Cryosurgery, cosmetic
- Cosmetic dermatology, 519
- Cosmetic Ingredient Review, 267
- Cosmetic Ingredient Review Expert Panel (CIR), 252
- Cosmetic products, 166
- Cosmetic rehabilitation, 330–339  
appearance restoration. *See* Appearance restoration  
intervening care, 330
- Cosmetics  
ethnic. *See* Ethnic cosmetics  
microneedles for. *See* Microneedles
- Cosmetics, for men, 365–376  
ageing of skin and, 365–366  
antiperspirants, 369  
beauty products, 370  
degradable products, 371–372  
deodorants, 369  
depilatories, 370  
distribution of adipose tissue and, 366  
filling, 370  
hair products, 368–369  
overview, 365  
patient selection and, 370–371  
shaving products, 366–367  
side effects of, 375–376  
site specific, 372–375  
skin aspects and, 366  
skin problems related to beard and, 367, 368  
skin thickness and, 365  
soft tissue filling and, 370  
sunscreens and self tanning, 370  
toilet water and eau de cologne, 366  
types of, 360  
washing products, 369
- Cosmetic skin parameters, climatic influence on  
analysis of, 31–32  
climate data with, 28, 29  
indoor climate, 36–40  
laser profilometry for, 28  
moisture-retaining effect, 33  
negative standards for, 28, 29  
outdoor climate, 33–36  
overview, 28  
positive standards for, 28, 29  
Ra parameter, 29  
Rz parameter, 29
- Cosmetic *vs.* antidandruff shampoo, 233
- Cosmoderm, 456
- Cosmoplast, 456
- Cotton-tipped dipstick technique, cryosurgery, 435
- Council of Better Business Bureaus, 283
- CPD. *See* Cyclobutyl pyridine dimers (CPD)
- Cranial electrotherapy stimulation (CES), 475–476  
for pain, 475–476
- CRBP. *See* Cellular retinol-binding protein (CRBP); Cytoplasmic retinol-binding protein (CRBP)
- Crow's feet area, 246
- Crow's feet lines, botulinum toxin (BT) for, 446
- Crow's feet wrinkles  
in men, 373
- CRS. *See* Confocal Raman spectroscopy (CRS)
- Cryogenics, 434
- Cryopeels  
sun-damaged skin and, 438
- Cryoprobe  
in cryosurgery, 435
- Cryosurgery, cosmetic, 434–441  
complications of, 440–441  
lesion selection for, 436  
mechanism of  
cell injury, 436  
heat transfer, 435  
inflammation, 436  
vascular stasis and occlusion, 436  
techniques of  
cotton-tipped dipstick, 435  
cryoprobe, 435  
thermocouple device, 435  
timed spot freeze technique, 434–435  
of vascular lesions, 436–438
- Cryotherapy, methods, 434
- CU. *See* Corneometer units (CU)
- Cultural factors  
in sensitive skin, 75
- Cumulative irritation test (CIT), 284
- Cushing's syndrome  
hirsutism and, 302
- Cutaneous microvasculature  
of skin, 5–7
- Cutaneous necrosis/ulceration  
postsclerotherapy, 298–299
- Cutaneous perfusion  
of aging skin, 22–25
- Cutaneous ulceration, 298–299
- Cuticle softeners, 256
- Cuticle tissue, 247
- Cuticle trimmer, 250–251, 254, 256
- Cutometer®, 137, 281
- Cutters, 248
- Cyanoacrylate glue, 243, 264
- Cyclobutane pyrimidine dimers (CPD), 204
- Cyclobutyl pyridine dimers (CPD), 41
- Cytokinins, 141
- Cytoplasmic retinol-binding protein (CRBP), 106
- Dandruff, 156, 230, 232  
active particle size, optimization of, 236  
antidandruff actives, 235  
clinical features, 230  
etiology, 231–235  
pathology, 230–231  
prevalence, 230  
severity, 232  
stratum corneum features, 234  
therapies and efficacy, 235–237  
treatment, 238–239
- Dark rings  
treatment of, 322
- D- $\alpha$ -tocopherol cream, 208, 209
- DBT. *See* Dibutyl phthalate (DBT)
- DC electric fields, endogenous, 468
- Dead sea salt (DSS), 177
- Décolleté wrinkles, for botulinum toxin (BT), 449, 450
- Decorative performed artificial nails, 264
- Deeper vessels, 496
- Delayed tanning (DT), 41
- Dendrites, 491
- Deodorants, 197  
for men, 369
- Depigmentation, 128
- Depigmenting agents, 311–315  
adenoside monophosphate disodium salt, 313  
arbutin, 313  
ascorbic acid, 313  
azelaic acid, 312  
chamomilla extract, 313  
chemical peels, 315  
combination therapies, 314  
cosmetic use of bleaching products, 314–315  
dermabrasion, 315
- [Depigmenting agents]  
5,5'-dipropyl-biphenyl-2,2-diol, 313  
ellagic acid, 313  
hydroquinone, 311–312  
hydroquinone derivatives, 312  
4-(4-hydroxyphenyl)-2-butanol, 313  
inhibitory oligopeptides, 314  
4-isopropylcatechol, 312  
kojic acid, 312–313  
liquid nitrogen cryotherapy, 315  
liquiritin, 313  
4-methoxy potassium salicylate, 313  
monobenzylether d'hydroquinone, 312  
monomethyl of hydroquinone, 312  
4-*n*-butylresorcinol, 312  
phenolic thioether, 312  
retinoid monotherapy, 313  
soy and soy-based products, 312  
thioctic acid, 313  
tranexamic acid, 313  
tranexamic acid cetyl ester hydrochloride, 313  
unsaturated fatty acids, 314
- Depilatories  
for hair removal, 307  
in men, 370
- Depth of penetration, 41  
components of, 42
- Dermabrasion  
for depigmentation, 315
- Dermaflex®, 281
- Dermajet technique, 346
- Dermalab®, 281
- Dermal collagen, 16–18, 212
- Dermal elastin, 18–20
- Dermal hypermelanosis, 311
- Dermal irritation, primary  
hand and body lotions and, 284
- Dermalive®, 371
- Dermal Torque Meter™, 281
- DermaRoller®, 418, 419
- Dermatitis, 277  
eyelid, 254, 264  
nail varnish, 254–255
- Dermatology  
antioxidant  
feverfew, 177  
grape seed extract, 178  
rosemary, 177–178  
antiwrinkle cosmeceuticals, 178  
atopic dermatitis, 176–177  
indigo naturalis, 177  
oatmeal, 177  
fibred cloths, 193  
oral hairy leukoplakia, 178  
psoriasis, 176–177  
skin hyperpigmentation, 176  
UV exposure, 190
- Dermicol-P35, 459
- Desquamation index (DI), 278
- Dexapanthenol  
skin protection efficacy of, 48
- DF. *See* Dissecting folliculitis (DF)
- DHA. *See* Dihydroxyacetone (DHA)
- DHICA. *See* 5,6-Dihydroxyindole-2-carboxylic acid (DHICA)
- DI. *See* Desquamation index (DI)
- Dibutyl phthalate (DBT), 252
- Diethylamino hydroxybenzoyl hexyl benzoate (DHHB), 201
- Diethylhexyl butamido triazone. *See* Uvasorb HEB
- Diethylhexyl 2,6-naphthalate (DEHN), 201
- Differential scanning calorimetry (DSC), 154
- Dihydroshingosine (DS), 152
- Dihydrotestosterone (DHT), 510

- Dihydroxyacetone (DHA), 33, 188  
 application of, 188  
 chemical structure of, 189  
 climatic data of, 36  
 exponential decay curves of, 36  
 for hypopigmented lesions, 317  
 Maillard reaction, 188  
 skin darkening, degree of, 189
- 5,6-Dihydroxyindole-2-carboxylic acid (DHICA), 176, 313
- Dihydroxyphenylalanine (DOPA), 128
- Diluents, nail varnish, 252
- 7,12-Dimethylbenzanthracene (DMBA), 213
- Dimethyl sulfoxide (DMSO), 64
- Disinfection container, 251
- Disposable nitrile gloves, 263
- Dissecting folliculitis (DF), 390
- Dithiodiglycolic acid (DTDG), 225
- DMSO. *See* Dimethyl sulfoxide (DMSO)
- DNA damage  
 UVB, 204
- DOPA. *See* Dihydroxyphenylalanine (DOPA)
- Doppler flowmetry, 5  
 cold-induced vasomotor response, 7
- Dose-equivalence, of botulinum toxin (BT), 442
- Dow Corning Corporation, 454
- Dried nail, 259
- Drug delivery  
 microneedles strategies for, 417, 418
- Drug-induced hypertrichosis, 306
- Drug-induced pigmentations, 322
- Drug-induced sensitivity, 77
- Drug penetration  
 in nail, 65  
 radiolabeled, 69
- Dry skin, 144, 405. *See also* Skin  
 application of detergent, 144  
 barrier recovery test in, 144  
 different levels of, 275  
 hydroxyacids and, 98  
 intraepidermal secondary factors, 144–145  
 involvement of plasmin, 145–146  
 moisturizers to alleviate, 274–276  
 plasminogen activator activity in, 146  
 preventing return of, 276  
 prevention of, 144, 145  
 urokinase in, 146
- DSC. *See* Differential scanning calorimetry (DSC)
- D-Squame<sup>®</sup>, 278
- DT. *See* Delayed tanning (DT)
- Dyschromia, 311–324  
 camouflaging, 317  
 causes of, 311  
 chemical peels, 315  
 defined, 311  
 depigmenting agents. *See* Depigmenting agents  
 dermabrasion, 315  
 lasers and phototherapy, 315–316  
 liquid nitrogen cryotherapy, 315  
 overview, 311  
 pathophysiology of, 311  
 pigmentary lesions, treatment of, 317–324  
 surgical approaches for, 316
- Dyskeratosis  
 treatment of, 323
- Dysport<sup>®</sup>, 442. *See also* Botulinum toxin (BT)  
 for bunny lines, 447  
 for crow's feet lines, 446  
 for décolleté wrinkles, 449  
 for depressor angulis oris, 449  
 dose recommendation for, 444  
 for forehead lines, 446  
 for gingival smile, 449  
 for glabellar lines, 445  
 for hyperhidrosis, 451
- [Dysport<sup>®</sup>]  
 for masseteric hypertrophy, 449  
 for mentalis, 448  
 for nasal tip droop, 447  
 for platysmal bands, 449
- Dystrophic nails, 265
- Easy Phytic Solution (EPS), 488–489
- ECM. *See* Extracellular matrix (ECM)
- EcoNail, 64
- Econazole shampoo, 238
- Eczema  
 defined, 99  
 hydroxyacids and, 99
- Eczema patients, 170  
 positive patch tests in, 166
- Edema, 290  
 cryosurgery and, 440
- EDTA. *See* Ethylenediaminetetraacetate (EDTA)
- EGCG. *See* Epigallocatechin gallate (EGCG)
- Elastic fibers  
 in periorbital wrinkles, 242
- Elasticity, of skin, 281–282
- Elastic recovery/extensibility, of skin  
 ethnic differences in, 399
- Elastin, 18–20
- Elastin enhancement  
 in total soy, 132–133
- Electric air bath, 466
- Electric currents at human skin wounds, 466
- Electric neurostimulation, 466
- Electric torpedo fish, 466
- Electrodermal asymmetry  
 of skin, 7
- Electrodesiccation, 495
- Electromagnetic radiation  
 effects of, 200
- Electron transfer chain  
 idebenone and, 111
- Electro-pressure regeneration therapy (EPRT), 474
- Electrosurgical epilation  
 disadvantages of, 307  
 for hair removal, 307
- Electrotherapy, therapeutic applications of, 466
- Ellagic acid  
 as depigmenting agent, 313
- Embolism  
 pulmonary, postsclerotherapy, 299
- Emery board, 248, 250
- Emollients  
 as ingredient, for hand and body lotion, 270–271
- Emulsifiers, 273  
 anionic, 272  
 cationic, 272  
 as ingredient, for hand and body lotion, 271–272  
 nonanionic, 272
- Emulsions  
 complex, 274  
 oil-in-water, 272, 273  
 water-in-oil, 273, 274
- Endermologie, 292
- Endogenous electric fields, 472–473  
 direct current, 468
- Endothelin-B receptors, 7
- Endovenous occlusion techniques, 299  
 for varicose veins, 299
- Energy enhancement  
 idebenone and, 111
- Ensulizole, 200
- Environmental factors  
 in sensitive skin, 76–77
- Environmental Protection Agency (EPA)-registered disinfectants, 257
- EPA-registered disinfectants. *See* Environmental Protection Agency (EPA)-registered disinfectants
- Epidermabrasion process  
 mechanization of, 194
- Epidermal hydration, in skin, 3
- Epidermal hypermelanosis, 311
- Epidermal innervation  
 ethnic differences in, 401
- Epidermal suspension, use of, 316
- Epidermis, 483. *See also* Skin  
 $\alpha$ -tocopherol concentrations in, 117, 118  
 humectants in, 184  
 hyaluronan distribution in, 84, 86–87  
 nickel content in, 47  
 plasmin in, 145–146  
 reactivity of ozone in, 117  
 retinoic acid level in, 125  
 sunburn cells in, 99  
 thickness of, 77, 122–123  
 in men, 74  
 in women, 7  
 UVB absorption in, 43
- Epigallocatechin gallate (EGCG)  
 photoprotective effects of, 119
- Epilator, 307
- EPRT. *See* Electro-pressure regeneration therapy (EPRT)
- EPS. *See* Easy Phytic Solution (EPS)
- e-PTFE. *See* Expanded polytetrafluoroethylene (e-PTFE)
- ER. *See* Estrogen receptor (ER)
- ERT. *See* Estrogen replacement therapy (ERT)
- Erythema, 44, 284
- Esterified  $\omega$ -hydroxy fatty acid (EO), 152
- Esthelis<sup>®</sup>, 371
- Estrogen receptor (ER), 11
- Estrogen replacement therapy (ERT), 405
- Estrogens, 5  
 skin aging and, 407
- Ethnic cosmetics, 379–383  
 acne vulgaris and, 381–382  
 cutaneous appendages, 380  
 exogenous ochronosis and, 382  
 irritant and allergic contact dermatitis, 382–381  
 post-inflammatory hyperpigmentation and, 382  
 skin color and, 379  
 stratum corneum and  
 pH, 380  
 structure, 379–380  
 water content, 380
- Ethnic diversity  
 of hair. *See* Hair, ethnic variation in  
 of skin. *See* Skin, ethnic differences in
- Ethylenediaminetetraacetate (EDTA), 47
- Ethyl methacrylate monomer, 262
- EU. *See* European Union (EU)
- European Union (EU), 252
- Evernia prunastri*, 166
- Evolence<sup>®</sup>, 371, 459
- Excessive hair. *See* Hair, excessive
- Exemplary light emission curve, 504
- Exfoliants  
 hydroxyacids, 192
- Exogenous ochronosis  
 in ethnic skin, 382
- Exotoxin, 442
- Expanded polytetrafluoroethylene (e-PTFE), 455
- Expression lines, 242
- Extracellular matrix (ECM)  
 hyaluronan in, 86
- Extrinsic aging, 87, 99
- Eye  
 irritation of, 287
- Eye bags  
 in men, 373

- Eye lashes  
ethnic differences in, 392
- Eyelids  
dermatitis, 254, 264
- FAA. *See* Free amino acids (FAA)
- Face, botulinum toxin (BT) for  
lower, 447–449  
depressor angulis oris, 448–449  
gingival smile, 449  
masseteric hypertrophy, 449  
mentalis, 448  
perioral area, 448  
middle, 447  
upper, 444–446  
crow's feet lines, 446  
forehead lines, 446  
glabellar lines, 445–446
- Face clothes, 193
- Facial asymmetry, botulinum toxin (BT) for, 446–447
- Facial disfigurement, 331
- Facial telangiectasias, 494, 499  
treatment of, 494
- Facial veins, 498
- Facial washing, 184
- Fade optical lengthigines, 135
- Fast optical in vivo topometry of human skin (FOITS), 28  
corneometer, 32–33  
data presentation of, 30  
parameter analysis of, 31–32  
regeneration of, 33  
technical parameters of, 30
- Fatty acids, 271  
chemical structure of, 151
- FC. *See* Fluorochemical (FC)-resin complex
- FD. *See* Folliculitis decalvans (FD)
- FDA. *See* Food and Drug Administration (FDA)
- FDC. *See* Federal Food, Drug and Cosmetic Act (FDC)
- FDD. *See* Frequency distribution of depth (FDD)
- Feathering, 441
- Febrifugia, 177
- Federal Food, Drug and Cosmetic Act (FDC), 283
- Federal Trade Commission Act (FTC), 283
- Female pattern hair loss (FPHL), 510
- Ferric ferrocyanide, 253
- Ferriman-Gallwey (F-G) score, 302, 304
- Feverfew  
photoprotective effects of, 119
- F-G score. *See* Ferriman-Gallwey (F-G) score
- Fiberglass, 265
- Fibrel, 454–455
- "Fibrin foam," 454
- Fibrinolytic enzymes, 144
- Fibroblasts  
peelings and, 491  
wrinkles and, 245–246
- Filling  
in men, 370
- Film-drying accelerant, 253
- Film former, 251
- Film modifier, 251–252
- Finasteride, 510, 511  
oral, 510
- Fine lines, 242
- Fish oil, 184
- Fitzpatrick skin phototype system, 396
- Flavonoid, 176
- Flip-top transplantation, 316
- FLPD lasers, 497
- Fluorochemical (FC)-resin complex, 47
- Foam sclerotherapy, 297–298, 298. *See also* Sclerotherapy
- Follicle-stimulating hormone (FSH), 10
- Folliculitis, 367
- Folliculitis decalvans (FD), 391
- Fomblin™, 52
- Fontana-Mason (F&M) staining, 128
- Food and Drug Administration (FDA), 127, 252, 283, 510
- Forehead wrinkles  
in men, 373
- Formaldehyde, 253  
pterygium inversum due to, 266, 267
- Formalin, 266
- FOTIS. *See* Fast optical in vivo topometry of human skin (FOITS)
- Fragrance allergens, 173, 174  
in pharmaceutical products, 173
- Fragrance allergic patient, 167
- Fragrance ingredients  
adverse reactions to, 165  
contact allergy to, 165–166  
list of substances, 167
- Fragrances  
adverse effects of, 285  
as ingredient, for hand and body lotion, 272–273
- Frail nails, 248
- Freckles  
treatment of, 321
- Free amino acids (FAA), 20
- Freeze-thaw cycles (FTC), 434
- Frequency distribution of depth (FDD), 31
- Fringe projection, 30
- FSH. *See* Follicle-stimulating hormone (FSH)
- FTC. *See* Federal Trade Commission Act (FTC); Freeze-thaw cycles (FTC)
- 0.5% 5-FU, 430
- 1% 5-FU, 430
- 5% 5-FU, 430
- Full-face phenol peeling, 493
- Furfuryl  
structure of, 142
- Furfuryladenine, 196
- GAG. *See* Glycosaminoglycans (GAG)
- Galen, A.D., 294
- Galvanic current, 477
- Galvanic electrolysis  
for hair removal, 307
- $\gamma$ -aminobutyric (GABA) type A receptor agonists, 157
- Gas chromatography, 55
- Gels  
matrix of aldobionic acids, 94  
spray, 225  
UV, artificial nails and, 262–263
- Gender  
sensitive skin and, 74–75
- Genistein, 212  
effect of, 213  
photoprotective effects of, 119
- Geraniol, 169
- clinical elicitation tests, human, 170–173
- human maximization test, 169
- industrial classification, 173
- LLNA tests, 169
- predictive tests, on animal, 169
- predictive tests, on human, 169
- GH. *See* Growth hormone (GH)
- Gingival smile, botulinum toxin (BT) for, 449
- Ginkgo biloba*, 292
- Glabella/interbrow wrinkles  
in men, 373
- Glabellar lines, botulinum toxin (BT) for, 445–446
- Glossometer GL 200, 182
- Glutaraldehyde, 261
- Glutathione (GSH), 133
- Glyceraldehyde, 188
- Glycerides, 271
- Glycerin, 269, 297  
for sclerotherapy, 297
- Glycolic acid  
for acne, 361  
peels, 315
- Glycosaminoglycans (GAG), 16, 84, 94, 184, 242  
biopolymer, 456. *See also* Hyaluronic acid (HA)  
structure, in skin, 20–22
- Glymatrix technology, porcine collagen cross-linked with, 459
- Gram stain test, 178
- Granulations  
of nail keratin, 255
- Granulomas, 462
- Green tea, 204  
as antioxidants, 119  
photoprotective effects of, 119
- Grenz zone peeling, 484–485
- Growth hormone (GH), 10
- GSH. *See* Glutathione (GSH)
- Guttate hypomelanosis, 315  
idiopathic, treatment of, 322
- HA. *See* Hyaluronic acid (HA)
- Hair  
blending, 513  
chemical and physical structures, 227  
conditioning, 223  
ethnic variation in, 386–393  
body hair, 392–393  
scalp hair. *See* Scalp hair  
long, 219
- Hair, excessive, 302–309. *See also* Hirsutism; Hypertrichosis  
causes of, 302–306  
cosmetic procedures for, 306–307  
bleaching, 306  
chemical depilatories function, 307  
electrosurgical epilation, 307  
plucking, 307  
shaving, 307  
sugaring and threading, 307  
trimming of the hair, 306–307  
waxing, 307  
history of, 302  
lasers and light sources for, 308–309  
medical treatment of, 307–308  
antiandrogens, 307  
insulin sensitizers, 307  
topical eflornithine cream, 307–308
- HAIR-AN syndrome  
hirsutism and, 302
- Hair care  
African-American hair relaxers, 226–227  
coloring/bleaching, 221  
conditioning materials  
cationic polymers, 223  
fatty alcohols, 223  
oil emollients, 223  
quats/amines, 223  
silicones, 223  
cosmetic hair problems, 221  
surface charge, 219–221  
weathering, 218–219  
hair, structure of  
caucasoid, negroid, and mongoloid, 218  
human hair, morphology of, 218  
hair friction, 225  
processes, 219

- [Hair care]  
 product design parameters, 227–228  
 products, 221  
   conditioning agents, 223  
   design of, 228  
   shampoos, 222–223  
 product types  
   alcohol, 226  
   hair spray, 226  
   pomades, 226  
   water-based styling polymers, 225–226  
   waxes, 226  
 regimens, 221–222  
 soy, in traditional use of, 128  
 special needs, 226  
 styling issues, 223–224  
 styling products, 225  
 volume problems  
   factors, 224  
 wet setting  
   blow-drying, 224–225  
   pressing, 225  
   setting, 225  
 Hair coloring, 219  
 Hair dryers, 225  
 Hair follicles, 218  
   x chromosome-linked inhibitor of apoptosis (XIAP) expression, 511  
 Hair loss, male pattern, 510  
 HairMax Laser-Comb, 511  
 Hair morphology, 218  
 Hair products, for men, 368–369  
   aminexil, 369  
   conditioners, 368  
   hair-coloring products, 368–369  
   hair thickeners, 369  
   minoxidil, 369  
   scalp camouflage, 369  
   shampoos, 368  
 Hair regrowth, delay in, 135–136  
 Hair restoration therapy, 511  
 Hair setting and hairstyling products, 368  
 Hair shaft  
   cross-section of, 218  
 Hair's natural oils, 225  
 Hair spray, 225, 226  
 Hair texture, 220  
 Halo nevi, 319  
 Hand and body lotions, 269–287  
   and acneogenesis, 285–286  
   adverse reactions, 283  
   use testing to assess, 287  
   and comedogenesis, 285–286  
   ingredients for, 270–283  
   classes of, 270–273  
   emollients as, 270–271  
   emulsifiers as, 271–272  
   fragrances as, 272–273  
   humectants as, 271  
   overview of, 270  
   positive patch test reactions to, 285  
   preservatives as, 272–273  
   skin care additives as, 273  
   UV light and, 287  
   water as, 270  
   water-soluble polymers as, 272  
 leading, in United States, 270  
 measuring skin dryness, 278  
 overview of, 269–270  
 physical structure of, 273–274  
   overview of, 273  
 and primary dermal irritation, 284  
 and sensitization, 284–285  
 toxicology of, 283  
*Handbook of Cosmetic Skin Care*, 412  
 HAS. *See* HA synthases (HAS)  
 HA synthases (HAS)  
   in hyaluronan synthesis, 85  
   isoforms of, 85  
 Hats, photoprotection of, 202  
 HB-EGF. *See* Heparin-binding epidermal growth factor (HB-EGF)  
 HDSS. *See* Hyperhidrosis Disease Severity Scale (HDSS)  
 Heat transfer  
   cryosurgery and, 435  
 Hemorrhage  
   cryosurgery and, 440  
 Heparin-binding epidermal growth factor (HB-EGF), 123  
 Hepatocyte growth factor (HGF), 510  
 Highly hand wash protocol, 276  
 Hirsutism, 302–304  
   causes of, 302  
   defined, 302  
   idiopathic, 302, 304  
   and menopause, 407–408  
   treatment of, 306–309  
 Histamine, 7  
 Hodgkin's lymphoma, 203  
 Hollow microneedles, 419–420  
*Homo sapiens*, 218  
 Hormonal influence  
   in skin, 10  
 Hormonal replacement therapy (HRT)  
   menopause and, 405  
   and skin aging, 406  
 Hormonal skin aging, 405–406  
 Hot curling, 225  
 4-HPB. *See* 4-(4-Hydroxyphenyl)-2-butanol (4-HPB)  
 HQ. *See* Hydroquinone (HQ)  
 HQ + KA  
   for depigmentation, 314  
 HRIPT. *See* Human repeated insult patch (HRIPT)  
 HRT. *See* Hormonal replacement therapy (HRT)  
 HS. *See* Hypertonic saline (HS)  
 HSD. *See* Hypertonic saline and dextrose (HSD)  
 Human collagen, 456  
 Human hair  
   cross-section of, 219  
   f-layer removal, mechanism of, 220  
   metal content of, 3  
   morphology, 219  
 Human nail plate  
   surface centre of, 67  
 Human repeated insult patch (HRIPT), 284  
 Human scalp  
   *Malassezia* sp., 234  
 Humectants, 184  
   as ingredient, for hand and body lotion, 271  
 HYAL. *See* Hyaluronidase (HYAL)  
 Hyaladherins, 85, 86  
 Hyaluronan, 84–88  
   aging and, 87  
   biology of, 84–85  
   in cosmetic applications, 87  
   derivatives as fillers, 87–88  
   distribution in epidermis, 86–87  
   in extracellular matrix, 86  
   functions of, 84, 85  
   size on, 85  
   history of, 84  
   hyaluronidase inhibitors, 85  
   photoaging and, 87  
   receptors, 85–86  
   as skin fillers, 87–88  
   structure of, 84  
   synthesis of, 85  
   HA synthases in, 85  
   in wound healing, 86  
 Hyaluronic acid (HA), 84–88, 371, 413, 456–457. *See also* Hyaluronidase (HYAL)  
   injection technique, 457  
   treatment with, 457  
 Hyaluronidase (HYAL), 85  
 Hyaluronidase inhibitors, 85  
 Hydration, 3  
   of nail bed, 66  
   of nail plate, 66  
 Hydrelle<sup>®</sup>, 371  
 Hydrocolloid masks, 194  
 Hydroquinone (HQ), 259  
   as depigmenting agent, 311–312  
   side effects of, 311–312  
 Hydroxyacids  
   AHA. *See* A-hydroxy acids (AHA)  
   aldobionic acids (ABAs), 93  
   amino acids and, 94  
   BHAs. *See*  $\beta$ -hydroxyacids (BHA)  
   bioavailability of, 95  
   biochemistry of, 94  
   cosmetic indications, 98–103  
   dermatological indications, 98–103  
   mechanism of action, 97, 98  
   biochemical action, 97  
   biological action, 97, 98  
   chemical structure, specificity of, 97  
   nomenclature of, 91–93  
   PHAs. *See* Polyhydroxyacids (PHA)  
   physicochemical properties of, 93–94  
   acid strength, 94  
   antioxidant property, 94  
   gel matrix, 94  
   lactone form, 94  
   solubility, 94  
   stereoisomers, 93–94  
   similarities and differences of, 101  
   topical action of  
     on dermal components, 95  
     on keratinization, 95, 96  
     in peel solutions, 96–97  
     in skin peeling, 96–97  
     on skin thickness, 95–96  
 4-Hydroxyanisole. *See* Monomethyl of hydroquinone (MMEH)  
 4-Hydroxyanisole + tretinoïne (Mequinol<sup>®</sup>)  
   for depigmentation, 314  
 4-(4-Hydroxyphenyl)-2-butanol (4-HPB)  
   as depigmenting agent, 313  
 6-Hydroxy sphingosine (H), 152  
 hylan gels, 455  
 Hyperhidrosis, 450–451  
   BT-A for, 451  
   causes of, 450  
   diagnosis of, 450  
   treatment for, 450–451  
 Hyperhidrosis Disease Severity Scale (HDSS), 451  
 Hyperkeratotic diseases, 197  
 Hypermelanosis, 311. *See also* Dyschromia  
   causes of, 311  
 Hyperpigmentation, 208  
   cryosurgery and, 440  
   medications for, 177  
   postsclerotherapy, 298–299  
 Hyperpigmented spots, reduction of, 134  
 Hypertonic saline and dextrose (HSD), 296  
 Hypertonic saline (HS), 295  
   for sclerotherapy, 296  
 Hypertrichosis, 304–306  
   acquired lanuginosa, 305  
   classification of, 304  
   congenital generalized, 305  
   defined, 304  
   drug-induced, 306  
   lumbosacral, 304

- [Hypertrichosis]  
and menopause, 407–408  
prepubertal, 305  
treatment of, 306–309  
universal congenital, 305
- Hypertrophic scars  
treatment of, 344–350  
*vs.* keloids, 341
- Hypoallergenic resin, 254, 263
- Hypomelanosis, 311. *See also* Dyschromia
- Hyponychium, 247
- Hypopigmentation  
cryosurgery and, 440–441
- Hypopigmented striae and iatrogenic leukoderma  
treatment of, 322
- ICAM1. *See* Intracellular adhesion molecule 1 (ICAM1)
- Idebenone  
as antioxidants, 111  
cell biology and, 112  
clinical research on, 112  
derivatives of, 113  
history of, 111  
photoprotective effects of, 119–120  
physicochemical properties of, 111  
safety of, 113  
patch test, 113  
uses of, 111  
*vs.* coenzyme Q10, 111, 112
- Idiopathic hirsutism  
defined, 302, 304
- IFRA. *See* International Fragrance Association (IFRA)
- Immediate pigment darkening (IPD), 41
- Immunology  
sensitive skin and, 79
- Immunosuppression, 42
- INCI. *See* International Nomenclature of Cosmetic Ingredients Dictionary (INCI)
- Indigo naturalis, 177
- Indoor climate, 36–40
- Infections  
mesotherapy and, 414–415  
nails, 256–257
- Inflammation  
cryosurgery and, 435
- Infrared light (IR), 292
- Infrared radiation (IR), 41  
cutaneous effects of, 44
- Injuries  
mesotherapy and, 413
- In-plane microneedles, 417, 418
- Instrumental evaluations  
of moisturizer efficacy, 277–278
- Insulin-like growth factor 1 (IGF-1), 510
- Insulin sensitizers  
for hirsutism, 307
- Intensity pulsed light (IPL) source, 498–499  
“Interceptive” antioxidant network, 116
- International Cosmetic Ingredient Dictionary, 270
- International Fragrance Association (IFRA), 167
- International Nomenclature of Cosmetic Ingredients Dictionary (INCI), 251, 266
- Intracellular adhesion molecule 1 (ICAM1), 85
- Intradermal botulinum toxin  
use of, 185
- Intraepidermic peeling, 482–483
- Intrahypodermic injections, 412
- Intrinsic aging, 99
- IPD. *See* Immediate pigment darkening (IPD)
- IR. *See* Infrared light (IR); Infrared radiation (IR)
- Irritant dermatitis, 3, 5
- Irritation  
eye, 287  
primary  
prevention of, 277  
reducing, 276–277  
sensory, 284–287
- Irritation index, for skin, 5
- Isoflavones  
skin aging and, 407
- Isoguvacine, 157
- Isoprenaline, 6
- 4-Isopropylcatechol (4-IPC)  
as depigmenting agent, 312
- Isotretinoin  
for acne, 354–358
- Jugal wrinkles  
in men, 373
- KA. *See* Kojic acid (KA)
- Kallikreins, 3
- Keloids, 341–350  
clinical examination of, 341  
cryosurgery of, 439–440  
etiology of, 341  
histology of, 341–342  
hypertrophic scars *vs.*, 341  
overview, 341  
pathogenesis of, 342–343  
treatment of, 344–350
- Keratinocytes, 269, 469, 472, 473  
effect of retinol on, 123
- Keratolytic agents  
for acne, 352–362  
azelaic acid, 359–360  
benzoyl peroxide, 352–353  
glycolic acid, 361  
in vivo potential of, 361–362  
overview, 352  
resorcinol, 361  
retinoids, 353–359  
salicylic acid, 360  
sulfur, 360–361
- Keratoses  
actinic  
hydroxyacids for, 100  
age spot  
hydroxyacids for, 100
- Ketoconazole cream, 64
- Ketoconazole shampoo, 237
- Ketoconazole *vs.* Selenium sulfide, 237
- Kinetin  
biology of, 141  
cell yield in, 143  
chemistry of, 141  
clinical studies of, 142–143  
effects on cytological manifestations of in vitro aging, 142  
mechanism of action, 141–142  
overview, 141  
structure of, 142
- Kligman regression protocol, 274, 275
- Kligman’s formula, for depigmentation, 314
- Koebner reaction, 259
- Kojic acid (KA)  
as depigmenting agent, 312–313
- Kreb’s cycle, 190
- KTP laser, 496
- Kunitz-type trypsin inhibitor, 128
- Lactone form  
of hydroxyacids, 94
- Lamellar ichthyosis, 155
- Lamellar layer, 290
- Langerhans cells, 269
- Lanolin, 270
- L-ascorbic acid. *See* Vitamin C
- Laser Doppler flowmetry (LDF), 22, 291
- Laser Doppler velocimetry (LDV), 22, 397
- Laser/light treatment, 501
- Laser profilometry, 28
- Laser resurfacing, 206
- Laser(s)  
for hair removal, 308–309  
for keloids and hypertrophic scars, 348  
for pigmentary disorders, 315–316  
for telangiectasia and varicose veins, 300
- Late onset congenital adrenal hyperplasia hirsutism and, 302
- LDF. *See* Laser Doppler flowmetry (LDF)
- LDV. *See* Laser Doppler velocimetry (LDV)
- Leg telangiectasias  
treatment of, 497
- Lemon peel, allergic, 170
- Lentigines  
treatment of, 321
- Lentigos, 500
- L-ergothioneine  
as antioxidants, 119
- LH. *See* Luteinizing hormone (LH)
- Lichen planus, 259
- Ligation, 299
- Ligation and stripping  
for varicose veins, 299
- Light-curing gels, 262–263
- Light sources  
for hair removal, 308–309  
in PDT, 423  
for telangiectasia and varicose veins, 300
- Linen, 264–265
- Lipid content, of skin  
ethnic differences in, 400
- Liquid nitrogen cryosurgery, 435
- Liquid nitrogen cryotherapy, 434  
for depigmentation, 315
- Liquid sclerotherapy, 295–296. *See also* Sclerotherapy
- Liquirtin cream, 176
- Local lymph node assay (LLNA) tests, 169
- Long-pulsed ruby lasers, 308
- Long pulse dye laser (LPDL), 495
- Lotions  
composition, 283  
consumers usage, 283  
effects of, on skin, 278–281  
expert panel testing of, 282  
hand and body. *See* Hand and body lotions  
measurement of, 55–56
- Lotion transfer, 56  
on absorbent core, 56–57, 58  
analysis using BTK test protocol, 60  
analysis using clinical in-use test protocol, 61  
efficiency BTK protocol *vs.* clinical in-use protocol, 57–58  
as function of lotion configuration, 59  
as function of pad thickness, 59  
lotion configuration on, 57  
on pad, 56, 57  
pad thickness of, 57  
rank order of, 61  
two test protocols, comparison of, 58–61
- Low-density lipoprotein (LDL), 212
- Lower face, botulinum toxin (BT)  
for, 447–449  
depressor angulis oris, 448–449  
gingival smile, 449  
masseteric hypertrophy, 449  
mentalis, 448  
perioral area, 448
- Lumbosacral hypertrichosis, 304
- Lupus erythematosus (LE), 259, 405
- Luteinizing hormone (LH), 10

- Magnetic resonance imaging (MRI), 290, 292
- Magnolignan  
as depigmenting agent, 313
- Mahonia aquifolium*, 176
- Maillard/browning reaction, 188
- Major free ceramide  
structure of, 153
- Malassezia furfur*, 230
- Malassezia japonica*, 233
- Malassezia restricta* genomes, 235
- Malassezia* yeasts, 231, 233, 235
- Male androgenetic alopecia, 510
- Marionette lines (labiochin folds)  
in men, 373–374
- Massage  
and cellulite, 292
- Masseteric hypertrophy, 449
- Matrix metalloproteinases (MMP), 16, 43, 123  
idebenone, 112
- Matting, telangiectatic, 298
- MBEH. *See* Monobenzylether d'hydroquinone (MBEH)
- MCG. *See* Membrane-coating granules (MCG)
- MEHQ. *See* Methyl ethyl hydroquinone (MEHQ)
- Melanins, 269, 311, 379
- Melanocyte-stimulating hormone (MSH), 11
- Melanoderma. *See* Hypermelanosis
- Melanosomes  
ethnic differences in, 395–397
- Melasma  
in ethnic skin, 383  
treatment of, 317, 318
- Melatonin  
photoprotective effects of, 119
- Membrane-coating granules (MCG), 150
- Men, cosmetics for. *See* Cosmetics, for men
- Mending, of nails, 264–265
- Menopause. *See also* Skin aging  
alopecia and, 408  
climateric keratodermas and, 408  
defined, 405  
genital discomfort and, 405  
hirsutism and, 407–408  
and HRT, 405  
hypertrichosis and, 407–408  
skin aging and, 405–406  
skin cares and, 407
- Menstrual pads, 55
- Mentalis, botulinum toxin (BT) for, 448
- Mentor Corporation, 455
- Mesodermic theory, 411–412
- Mesolift, defined, 410
- Mesotherapy, 293, 410–415  
advantages of, 412  
adverse reactions/complications of, 413–415  
Bicheron's microcirculatory theory and, 411  
contraindications to, 413  
controversies related to, 415  
history of, 410  
indications of, 413  
mesodermic theory and, 411–412  
overview, 410  
pistorian reflex theory and, 411  
products for, 412–413  
techniques for, 412  
third circulation theory and, 412
- Metallic gradual hair colors, 368
- Metallized paperboard template, 259, 260
- Methacrylic acid, 262
- Methemoglobinemia, 264
- 4-Methoxy potassium salicylate (4-MSK)  
as depigmenting agent, 313
- 18-Methyl eicosanoic acid (18-MEA), 218
- Methylene glycol, 266
- Methyl ethyl hydroquinone (MEHQ), 259
- Methylxanthines, 292
- METS. *See* Microcurrent stimulation (METS)
- Microcomedones  
formation of, 352
- Microcurrent stimulation (METS)  
effects on cellular proliferation, 473–474  
effects on tenocyte proliferation, 473  
DNA content, 473–474
- Microcurrent therapy, for pain, 475–476
- Microdermabrasion, 194
- Microfine titanium dioxide, 202
- Microneedle arrays, 468
- Microneedles  
fabrication, 417  
hollow, 419–420  
overview, 417  
rollers, 417  
safety of, 420  
solid, 418–419  
strategies for drug delivery, 417, 418
- Middle face, botulinum toxin (BT) for, 447
- Mineral oil, 184, 271
- Minimal erythema dose (MED), 200, 206, 505
- Minimum inhibitory concentrations of  
growth (MICs), 235
- Minoxidil, 369, 510
- Mirroring tactics  
appearance restoration and, 331
- Mitochondria, 159
- Mitochondrial theory of aging, 111–112
- Mixed hypermelanosis, 311
- MMEH. *See* Monomethyl of hydroquinone (MMEH)
- MMP. *See* Matrix metalloproteinases (MMP)
- Moist skin, 38
- Moisture, 33
- Moisturizers, 520  
advertising claims made for, 283  
efficacy, 274–278  
bioengineering studies, 520  
bioengineering techniques, 519, 522  
clinical evaluation of, 274–278  
descriptors of, 283  
instrumental, 277–278  
overview of, 274  
studies, 520  
performance, consumer evaluation of, 282
- Moisturizing shampoos, 222
- Monobenzylether d'hydroquinone (MBEH)  
as depigmenting agent, 312
- Monomethyl of hydroquinone (MMEH)  
as depigmenting agent, 312
- Mositurization balance  
in skin, 137
- Mousses, 226
- MRI. *See* Magnetic resonance imaging (MRI)
- MSH. *See* Melanocyte-stimulating hormone (MSH)
- 4-MSK. *See* 4-Methoxy potassium salicylate (4-MSK)
- MTS-Roller™, 418, 419
- Muller, Robert, 294
- Muscles  
subcutaneous, skin and, 245
- Musimol, 157
- Mycobacterium chelonae*  
mesotherapy and, 414
- Myroxylon pereirae*, 166
- Myxoid cyst  
cryosurgery of, 434
- NACDG. *See* North American Contact Dermatitis Group (NACDG)
- NAD. *See* National Advertising Division (NAD)
- Na/H antiporter channel (NHE1)  
in aged skin, 15
- Nail bed, 260
- hydration of, 66
- Nail lacquer, 64
- Nail Manufacturers Council (NMC), 252
- Nail penetration  
chemical properties of, 63–64  
methodology of, 64–66  
overview, 63  
physical properties of, 63–64  
profile of, 68  
results of, 66–70
- Nail plates, 64  
hydration of, 66
- Nail polish  
as hardeners, 265–266  
removing, 262
- Nails  
allergic reactions, 260–261  
anatomy of, 247, 248  
applied cosmetics, reactions to, 254–256  
nail varnish dermatitis, 254–255  
recurrent urticaria, 255  
art, 247, 249  
artificial. *See* Artificial nails  
base coats, 253  
blocks, 250  
brittle, 248  
buffers, 250  
chemical formulations, 64  
creams, 254  
cuticle softeners, 256  
cuticle trimmer, 250–251, 254  
cutters, 248  
decoration of, 247–248, 249  
disinfection, 251, 257  
dosing procedure for, 64  
effects of, 67, 69  
dried, 259  
dystrophic, 265  
emery board, 248, 250  
enhancer effects, 69  
files, 250  
formulations for, 64  
frail, 248  
gel, 262–263  
hardeners, 265–267  
incubation, 64–65  
conditions of, 66  
injuries/infections, 256–257  
keratin granulation, 255  
lotions, 254  
mass balance of radioactivity recovery, 67  
mending, 264–265  
nippers, 248  
nonallergic reactions, 261–262  
pedicures, 251  
permanent loss of, 261  
plastic press-on, 263  
plate for, 64  
prosthetic, 260  
pushers, 250  
radiolabeled drug penetration of, 69  
sampling of, 65–66  
accuracy of, 67  
sanitation, 257  
sculptured, 260  
shape of, 247, 248  
staining, 255  
sterilization, 257  
surface washing procedure for, 64  
effects of, 69  
texture of, 248, 249  
tips  
shaping, different stages for, 265  
top coats, 253  
varnish formulation, 251–253  
color additives, 252–253  
film former, 251  
film modifier, 251–252  
plasticizers, 252

- [Nails  
 varnish formulation]  
 solvents and diluents, 252  
 stabilizers, 252  
 viscosity modifiers, 252  
 water-based varnishes, 253–254  
 whitener, 251  
 wrapping, 264–265, 266  
 Nail varnish solvents, 254  
 Nappage technique  
 of mesotherapy, 412  
 Nasal tip droop, botulinum toxin (BT) for, 447  
 NASHA. *See* Nonanimal source hyaluronic acid (NASHA)  
 Nasolabial folds  
 in men, 372  
 National Advertising Division (NAD), 283  
 Natural moisturizing factor (NMF), 182  
 4-n-Butylresorcinol (Rucinol®)  
 as depigmenting agent, 312  
 Nd:YAG laser, 300, 308, 309  
 Necrosis  
 mesotherapy and, 413–414  
 postsclerotherapy, 298–299  
 negative breeze, 466  
 Neskasir, 302  
 Neurological disorder  
 sensitive skin and, 79–80  
 Neurotoxicity  
 idebenone and, 111  
 Nevus depigmentosus  
 treatment of, 319  
 Nevus spilus  
 treatment of, 321  
 Newfill®, 371  
 N6-furfuryladenosine, 141  
 N6-furfuryladenine  
 structure of, 142  
 NHE1. *See* Na/H antiporter channel (NHE1)  
 NH<sub>4</sub>OH. *See* Ammonium hydroxide (NH<sub>4</sub>OH)  
 Nippers, 248  
 Nitrocellulose, 252  
 Nitroethane, 262  
 Nitrogen, liquid. *See* Liquid nitrogen  
 cryosurgery  
 Nitroprusside, 6  
 NMC. *See* Nail Manufacturers Council (NMC)  
 NMR. *See* Nuclear magnetic resonance (NMR)  
 2-n-nonyl-1,3-dioxolane (SEPA), 64, 69  
 No-light cyanoacrylate gels, 263  
 Nonallergic reactions, nails, 261–262  
 Nonanimal source hyaluronic acid  
 (NASHA), 87  
 Nonanionic emulsifiers, 272  
 Nondenatured soy proteins, 128  
 western blots comparing of, 132  
 Nonmelanoma skin cancers (NMSCs), 203  
 Nordic hair, 224  
 North American Contact Dermatitis Group  
 (NACDG), 283  
 Nose  
 dorsum and “saddling” (flattening) of, 375  
 raising tip of, 375  
 Nova™ Dermal Phase Meter, 281  
 NPA. *See* N-(phosphonomethyl)amino acids  
 (NPA)  
 N-(phosphonomethyl)amino acids (NPA), 103  
 N-Tralig injector, 346–347, 347  
 Nuclear magnetic resonance (NMR), 154  
 Obesity  
 sclerotherapy and, 295  
 Occlusion, vascular  
 cryosurgery and, 436  
 Occupational Safety and Health Administration  
 (OSHA), 252  
 Ochronosis  
 in ethnic skin, 382  
 treatment of, 323  
 OCT. *See* Optical coherence tomography (OCT)  
 Octinoxate, 200  
 Odors  
 causes of, 369  
 Oil-in-water (O/W) emulsions, 272, 273  
 Oligomeric proanthocyanidins, 178  
 Oligometric proanthocyanides, 197  
 Oligopeptides, inhibitory  
 as depigmenting agent, 314  
 Onychia, allergic, 264  
 Onycholysis, 256, 260, 262, 266, 267  
 Onychomycosis, 476  
 hydroxyacids and, 99  
 topical therapy for, 70  
 Onychoschizia, 249  
 OP. *See* Organophosphorus compounds (OP)  
 Open spray technique, cryotherapy, 434  
 Optical coherence tomography (OCT), 181,  
 278–279  
 Optosil®, 28  
 Organic acids, 91–104  
 Organophosphorus compounds (OP), 48  
 Organ protection  
 idebenone and, 111  
 OSHA. *See* Occupational Safety and Health  
 Administration (OSHA)  
 Osler-Weber-Rendu syndrome, 494  
 Ota nevi  
 treatment of, 321  
 Outdoor climate, 33–36  
 Out-of-plane needles, 417, 418  
 O/W emulsions. *See* Oil-in-water (O/W)  
 emulsions  
 Oxalalone, 133  
 Oxidation  
 defined, 94  
 free radicals, 503  
 Oxidative stress  
 antioxidants and, 115  
 Oxygen radicals, 141  
 Ozone  
 effect on antioxidants, 117  
 Padded chamois buffers, 250  
 Padimate, 200  
*Paenonia lactiflora*, 178  
 Pain  
 CES for, 475–476  
 cryosurgery and, 440  
 microcurrent therapy for, 475–476  
 Pain sensation  
 of skin, 7–8  
 Panniculitis  
 mesotherapy and, 414  
 Papillary dermis peeling, 485–486  
 PAR-2. *See* Protease-activated receptor 2  
 (PAR-2) pathway  
 Paraaminobenzoic acid (PABA), 200  
 Parfum  
 defined, 167  
 Paronychia, 260, 264  
 Parsol SLX, 201  
 Patch tests, 170  
 hand and body lotions ingredients and, 285  
 for idebenone, 113  
 sculptured artificial nail and, 261  
 sensitive skin and, 78  
 4-4PC. *See* 4-Isopropylcatechol (4-4PC)  
 PCOS. *See* Polycystic ovary syndrome (PCOS)  
 PCPC. *See* Personal Care Products Council  
 (PCPC)  
 PDGF. *See* Platelet-derived growth factor  
 (PDGF)  
 PDL. *See* Pulsed dye laser (PDL)  
 PDL treatment technique, 497  
 PDT. *See* Photodynamic therapy (PDT)  
 Pedicures, 251  
 Peelings  
 basal layer, 483–484  
 in ethnic skin, 383  
 exfoliation, 482  
 and fibroblasts, 491  
 grenz zone, 484–485  
 intraepidermic, 482–483  
 overview, 482  
 papillary dermis, 485–486  
 phenol, 492–493  
 full-face peeling, 493  
 local peeling, 492  
 reticular dermis, 486–487  
 TCA. *See* Trichloroacetic acid (TCA)  
 Penlac nail lacquer, 64  
 Perceived age, 242  
 Perfumes  
 applications of, 165  
 defined, 165  
 Perimenopause, defined, 405  
 Perionychium, 247  
 Periorbital wrinkles, 242–246  
 computer model of, 243–245  
 physical constants used in, 245  
 strains calculated in, 245  
 elastic fibers in, 242  
 treatment of, 246  
 Periorbital wrinkles, correction of  
 D- $\alpha$ -tocopherol cream, 208  
 L-selenomethionine lotion, 211  
 Peroxisome proliferator-activated receptors  
 (PPAR) agonists, 292  
 Peroxisome proliferators-activated receptor  
 (PPAR)- $\delta$ -mediated signaling  
 pathway, 155  
 Persistent pigment darkening (PPD), 41  
 Personal Care Products Council (PCPC), 270  
 Petrolatum, 270  
 ability of, 277  
 in alleviating dry skin, 275  
 pH, of skin  
 ethnic differences in, 399–400  
 hydroxyacids and, 95  
 PHA. *See* Polyhydroxy acids (PHA)  
 Pharmacological agents  
 cellulite and, 292  
 Phenol, 492–493  
 full-face peeling, 493  
 local peeling, 492  
 for reticular dermis peeling, 487  
 Phloretin, 210  
 Photoaging, 43, 111  
 antioxidants and, 100–101  
 ATRA and, 123  
 clinical difference between, 43  
 continuous wave lasers  
 argon laser, 496  
 carbon dioxide lasers, 496  
 flashlamp pumped-pulsed dye laser,  
 496–497  
 KTP lasers, 496  
 cooling, role of, 499  
 pigmented lesions, 500  
 Q-switched lasers, 500  
 copper vapor laser, 497–498  
 electrosurgery, 495–496  
 hyaluronan and, 87  
 intensity pulsed light (IPL) source, 498–499  
 photothermal effects, 500  
 in IR, 44  
 laser/light treatment, 501  
 lasers, 496  
 laser selection, 501

- [Photoaging]  
 long-pulse dye lasers, 497  
 long pulse Nd, 498  
 poikilodermatous type of, 499  
 retinoids and, 123–126  
 ultraviolet radiation and, 87  
 vascular lesions, 494–495
- Photoaging, bimolecular complex for, 478–480  
 eye areas, 479  
 laxity clinical study, 479  
 with natural extracts, 479  
 placebo-controlled antiaging study, 478–479
- Photocarcinogenesis, 43  
 reactive oxygen species and, 111
- Photochemiluminescence analysis, 504  
 Photochemiluminescence device, 503
- Photodamage  
 genistein, 212–214  
 histologic correction of  
 topical antioxidants, 209, 210  
 inorganic filters  
 automobile glass, 203  
 clothing, 202  
 hats, 202  
 makeup, 202–203  
 shade, 202  
 sunglasses, 202  
 sunless tanning agents, 203  
 window glass, 203
- IR, cutaneous effects of, 44  
 overview, 41  
 prevention and treatment  
 with antioxidants, 204  
 with dietary agents, 204  
 retinol and, 125  
 reversal of  
 topical antioxidants, 211  
 selenium, 210–212  
 with vitamin E, 212  
 sunscreens, use of, 200  
 ultraviolet radiation  
 acute effects of, 41–43  
 chronic effects of, 43  
 UVA filters, organic, 201–202  
 UVB filters, organic, 200–201  
 visible light, cutaneous effects of, 43–44  
 vitamin C, 206–207  
 vitamin C with E  
 and ferulic acid, 210  
 UV-induced erythema, 209  
 vitamin C with ferulic acid  
 and phloretin, 210  
 vitamin E, 207–209
- Photodamage, of skin  
 ethnic differences in, 401–402
- Photodynamic therapy (PDT), 204, 418, 422–428  
 history of, 422  
 light source in, 423  
 out-of-label indications of, 426–427  
 and pain, 427–428  
 photosensitizing in, 422–423  
 principle of, 422–424  
 validated indications of, 424–426
- Photolyase, 204
- Photoprotection  
 public education on, 203  
 topical antioxidants and, 118–120
- Photoreactions, 115, 286
- Photosensitive disorders, 190
- Photosensitizing  
 PDT and, 422–423
- Phototherapy  
 for pigmentary disorders, 315–316
- Photothermal effects, 500
- Physical sunscreens  
 advantages of, 198
- Phytic acid, 489
- Phytoestrogens  
 skin aging and, 407
- Phytosphingosine (P), 152
- Phytosterols, 131  
 soy, 183
- Piebaldism  
 treatment of, 319
- Pigmentary mosaicism  
 treatment of, 322
- Pigmentation, 44, 298–299, 311. *See also*  
 Dyschromia  
 drug-induced, 322  
 due to stasis dermatitis, treatment of, 322  
 post-inflammatory, 322  
 postsclerosis, 298  
 defined, 298
- Pigmented lesions, 500
- Pigmented seborrheic keratosis  
 treatment of, 321
- Pigment lake, 253
- PIH. *See* Post-inflammatory hyperpigmentation (PIH)
- Pilosebaceous unit  
 in skin, 10–11
- Pistorian reflex theory, 411
- Pityrosporum* genus, 185  
*Pityrosporum ovale*, 181, 231
- Plant antioxidants, 196
- Plasmin  
 in skin diseases, 145–146
- Plasminogen activator activity  
 in dry skin, 146  
 in intact skin, 148
- Plasticity, 3
- Plasticizers, 252, 259
- Plastic press-on nails, 263
- Platelet-derived growth factor (PDGF), 342
- Platysmal bands, botulinum toxin (BT)  
 for, 449
- Plicometry, 291–292
- PLLA. *See* Poly-L-lactic acid (PLLA)
- Plucking, 307
- PMH. *See* Progressive macular hypomelanosis (PMH)
- PMMA. *See* Polymethylmethacrylate (PMMA)
- PMN. *See* Polymorphonuclear leukocyte (PMN)
- PMS. *See* Polymultichrome stain (PMS)
- POEMS syndrome, 305–306
- Poikiloderma of Civatte  
 treatment of, 321
- Point-by-point technique (PPP)  
 of mesotherapy, 412
- POL. *See* Polidocanol (POL)
- Polidocanol (POL), 294, 296–297  
 for sclerotherapy, 296–297
- Polycarboxy AHAs, 92
- Polycystic ovary syndrome (PCOS)  
 hirsutism and, 302
- Polyhydroxyacids (PHA), 92–93  
 aldaric acid, 93  
 aldonic acid, 92–93  
 alduronic acid, 93
- Polyiodinated iodine, 297  
 for sclerotherapy, 297
- L-Poly-lactic acid, 371
- Poly-L-lactacid (PLLA), 459–460
- Polymers  
 acrylic acid, 272  
 cellulosic, 272  
 water-soluble, 272
- Polymethylmethacrylate (PMMA), 371, 455, 460, 461–462  
 adverse effects with, 461–462  
 injection technique, 462
- Polymorphonuclear leukocyte (PMN), 352
- Polymultichrome stain (PMS), 278
- Polyphenols  
 photoprotective effects of, 118–119
- Polypodium leucotomos, 204
- Polyunsaturated fatty acids (PUFAs), 184
- Pomades, 226
- Pomegranate fruit extract  
 photoprotective effects of, 119
- Porcine collagen, cross-linking with  
 Glymatrix technology, 459
- Porphyrias, 405
- Post-inflammatory hyperpigmentation (PIH), 137  
 in ethnic skin, 382, 383
- Postmenopause, defined, 405
- Postsclerosis pigmentation, 298  
 defined, 298
- Postsclerotherapy hyperpigmentation,  
 298–299
- PPAR. *See* Peroxisome proliferators-activated receptor (PPAR)- $\delta$ -mediated signaling pathway
- PPAR agonists. *See* Peroxisome proliferator-activated receptors (PPAR) agonists
- PPD. *See* Persistent pigment darkening (PPD)
- PPP. *See* Point-by-point technique (PPP)
- Prall's quantization, 278
- Precapillary arteriolar sphincter, 290
- Preformed artificial nails, 263–264  
 decorative, 264  
 in gold plate, 264
- Pregnancy  
 sclerotherapy and, 295
- Premenopause, defined, 405
- Prepubertal hypertrichosis, 305
- Preservatives  
 adverse effects of, 285  
 as ingredient, for hand and body lotion,  
 272–273
- Pressure sensitivity  
 of skin, 7–8
- Progestins, 405
- Progress Homme, 368–369
- Progressive macular hypomelanosis (PMH)  
 treatment of, 322–323
- ProMechanica<sup>®</sup>, 243
- Propecia. *See* Finasteride  
*Propionibacterium acnes*, 180
- Prostaglandin F2 alpha, 511
- Prosthetic nail, 260
- Protease-activated receptor 2 (PAR-2)  
 pathway, 128
- Protein  
 structure, in skin, 20–22
- Pro-urokinase plasminogen activator (uPA)  
 structure of, 147
- Pruritus  
 hydroxyacids and, 99
- Pseudochromhidrosis  
 treatment of, 323–324
- Pseudofolliculitis, 367, 368
- Pseudofolliculitis barbae, 390  
 in ethnic skin, 383
- Psoralen plus UVA (PUVA), 212
- Psoriasis, 145, 155, 259  
 epidermal hypertrophy in, 146
- Psoriasis-associated severity index (PASI), 176
- Psoriasis/atopic dermatitis/pruritus  
 medications for, 177
- Pterygium inversum, 266, 267
- PTZ-containing shampoos, 239
- PTZ possessors, 236
- Puberty  
 skin changes in men and, 366
- Pulmonary embolism, 299  
 postsclerotherapy, 299
- Pulsed dye laser (PDL), 298, 300, 494



- Punch grafting technique, 316  
*Punica granatum*, 183  
 Purpura, 497  
 Pushers, nails, 250  
 Pycnogenol, 176  
 Pyogenic granuloma  
 cryosurgery of, 436, 438  
 Pyratine-6 (furfurylaminotetrahydropyranyladenine), 141
- QS Alexandrite laser, 500  
 Q-switched ruby laser, 298  
 Quantitative risk assessment (QRA), 173
- Radiation therapy  
 for acne, 353–359  
 adapalene, 358–359  
 isotretinoin, 354–358  
 tazarotene, 358  
 tretinoin, 354  
 for keloids, 350  
 Radiesse, 455, 458. *See also* Calcium hydroxylapatite (CaHA)  
 Radio frequency (RF), 292  
 Raman confocal microscopy, 277, 278  
 Raman microspectroscopy, 521  
 Raman spectroscopy, 20  
 Ra parameter, 29  
 RAR. *See* Retinoic acid receptors (RAR)  
 Raynaud's phenomenon  
 in women skin, 5  
 RBP. *See* Retinol-binding protein (RBP)  
 Reactive nitrogen species (RNS), 115  
 Reactive oxygen species (ROS), 115, 183, 503  
 formation of, 115  
 photocarcinogenesis, 111  
 Rebalance, 248  
 Receptor for HA-mediated motility (RHAMM), 85, 86  
 Redexis<sup>®</sup>, 371  
 Regression test  
 skin dryness and, 274, 276  
 Rehabilitation  
 cosmetic. *See* Cosmetic rehabilitation  
 Rejuvenation  
 skin, racial differences and, 383–384  
 Relative humidity (RH), 505  
 Relaxer types, comparison of, 227  
 Repeated insult patch tests (RIPT), 131  
 Repeated open application test (ROAT), 171, 287  
 Repeated short-term occlusive irritation test (ROIT), 49, 277  
 Repeat insult patch tests (RIPT), 478  
 Repetitive irritation test (RIT), 48  
 Research Institute for Fragrance Materials (RIFM), 285  
 Resorcinol  
 for acne, 361  
 Restylane<sup>®</sup>, 371  
 Reticular dermis peeling, 486–487  
 Reticular veins, 295  
 treatment of, 295  
 11-cis-Retinaldehyde, 123  
 Retinal pigment epithelium (RPE) protein, 123  
 9-cis-Retinoic acid, 123  
 Retinoic acid (RA), 210  
 Retinoic acid receptors (RAR), 106, 353  
 Retinoids, 106  
 dyschromia and, 313  
 in vivo keratolytic potential of, 361–362  
 isomers of, 123  
 for keloids, 347  
 structure of, 123, 124  
 cyclic group, 123  
 polar group, 123  
 polyene group, 123
- Retinoid X receptors (RXR), 106, 353  
 Retinol  
 antiaging effects of, 125  
 biochemistry of, 106–108  
 chemical structure of, 107  
 clinical aspect of, 124  
 effect on cell, 123–124  
 effect on skin, 123–124  
 efficacy of, 124–125  
 irritation correlation with retinyl esters, 108, 109  
 metabolic pathways of, 107  
 metabolism of, 123  
 molecular biology of, 106–108  
 photoaging and, 123–126  
 source of, 123  
 Retinol-binding protein (RBP), 123  
 Retinyl esters, 123  
 biochemistry of, 106–108  
 chemical structure of, 107  
 molecular biology of, 106–108  
 Revanesse<sup>®</sup>, 371  
 RF. *See* Radio frequency (RF)  
 RHAMM. *See* Receptor for HA-mediated motility (RHAMM)  
 Rhinophyma  
 cryosurgery for, 439  
 RIFM. *See* Research Institute for Fragrance Materials (RIFM)  
 RIPT. *See* Repeated insult patch tests (RIPT)  
 RIT. *See* Repetitive irritation test (RIT)  
 RNS. *See* Reactive nitrogen species (RNS)  
 ROAT. *See* Repeated open application test (ROAT)  
 ROIT. *See* Repeated short-term occlusive irritation test (ROIT)  
 ROS. *See* Reactive oxygen species (ROS)  
 Rosacea  
 hydroxyacids and, 98  
 photoaging, 495  
 Rosemary, 177  
 ROS formation, 44  
 Rougher hyperkeratotic skin, 188  
 RPE. *See* Retinal pigment epithelium (RPE) protein  
 Rubber masks, 194  
 RXR. *See* Retinoid X receptors (RXR)  
 Rz parameter, 29
- SA. *See* Salicylic acid (SA)  
 SAIB. *See* Sucrose acetate isobutyrate (SAIB)  
 Salicylates, 200  
 Salicylic acid (SA), 184  
 for acne, 360  
 in vivo keratolytic potential of, 361–362  
 Sanitation, nails, 257  
 SBC. *See* Sunburn cells (SBC)  
 SC. *See* Stratum corneum (SC)  
 Scalp hair  
 features of, 386  
 human, ethnic difference in, 386–391  
 biochemistry, 388  
 care and styling, 389–390  
 characteristics, 388–389  
 color, 388  
 density, 387  
 disorders, 390–391  
 growth, 387–388  
 shape and thickness, 386–387  
 SCC. *See* Squamous cell carcinoma (SCC)  
 SC ceramides  
 barrier repair of, 157–159  
 biosynthesis of, 157–159  
 pathways leading to synthesis of, 152
- [SC ceramides]  
 structure of, 150–154  
 variations in, 155–157  
 SCCP. *See* Scientific Committee on Consumer Products (SCCP)  
 SC hydration, 16  
 SCI. *See* Spinal cord injury (SCI)  
 SCID. *See* Severe combined immunodeficiency (SCID) mice  
 Scientific Committee on Consumer Products (SCCP), 252  
 Sclerosing solutions, 295–298  
 chemical irritants, 297  
 hypertonic saline, 295  
 polidocanol, 296–297  
 sodium morrhuate, 297  
 sodium tetradecyl sulfate, 297  
 Sclerotherapy, 294, 295  
 compression in, 294  
 contraindication to, 295  
 foam, 297–298  
 general principles of, 295  
 hands position for, 295–296  
 history of, 294  
 liquid, 295–296  
 obesity and, 295  
 overview, 294  
 position of hands for, 295  
 sclerosing solutions, 295–298  
 chemical irritants, 297  
 hypertonic saline, 295  
 polidocanol, 296–297  
 sodium morrhuate, 297  
 sodium tetradecyl sulfate, 297  
 sclerosing solutions for, 296–297  
 chemical irritants, 297  
 classification of, 296  
 comparison of, 297  
 foamed, 297  
 hypertonic saline, 296  
 polidocanol, 296–297  
 sodium morrhuate, 297  
 sodium tetradecyl sulfate, 297  
 side effects/complications of, 298–299  
 arterial injection, 299  
 cutaneous necrosis/ulceration, 298–299  
 postsclerotic pigmentation, 298  
 pulmonary embolism, 299  
 superficial thrombophlebitis, 299  
 telangiectatic matting, 298  
 spider veins and, treatment of, 295  
 technique of, 295–298  
 Sculptra<sup>®</sup>, 371, 455. *See also* Poly-L-lactic acid (PLLA)  
 Sculptured artificial nail, 260  
 patch testing and, 261  
 removing, 262  
 Sebaceous glands, 180, 182  
 Seborrheic dermatitis  
 clinical features, 230  
 etiology, 231–235  
 non-scalp, 235  
 pathology, 230–231  
 prevalence, 230  
 therapies and efficacy, 235–237  
 Seborrheic keratosis  
 cryosurgery for, 439  
 Sebum content/secretion, of skin  
 ethnic differences in, 400–401  
 Sebum excretion, measurement of, 182  
 Sebum production, in skin, 137  
 Selenium, 210  
 Selenium sulfide, 236  
 Self-tanning products  
 dihydroxyacetone (DHA), 188  
 application of, 188–189  
 indications, 189–190

- [Self-tanning products  
 dihydroxyacetone (DHA)]  
 safety, 190  
 site of action, 188  
 sunscreen activity, 189  
 Maillard/browning reaction, 188  
 tanning pills, 190
- Senile xerosis, 156
- Sensitive skin  
 barrier function, alterations, 74  
 defined, 73  
 etiology of, 73–74  
 factors of  
 age, 75  
 anatomic site, 77  
 cultural factors, 75  
 environmental, 76–77  
 ethnicity, 75, 76  
 gender, 74–75  
 immunology and, 79  
 methodologies used for, 80  
 neurological aspects of, 79–80  
 objective signs, 77–78  
 overview of, 73  
 physical response, increasing sensitivity  
 for, 78  
 prevalence of, 74  
 sensory effects, 77–78  
 sensory response, 78  
 test conditions, exaggeration of, 78
- Sensitization  
 hand and body lotions and, 284–285
- Sensory impairment  
 cryosurgery and, 441
- Sensory panel, trained expert  
 product evaluation by, 282–283
- SEPA. *See* 2-n-nonyl-1,3-dioxolane (SEPA)
- Serine palmitoyl transferase (SPT), 155
- Sesamol, 183
- Severe combined immunodeficiency (SCID)  
 mice, 132
- Shampooing, 222
- Shampoos  
 formulation, classical, 222  
 for men, 368
- Shape, of nails, 247, 248
- Shaving, 307  
 products, 366–367
- Silatriazole, 201
- Silicium, organic, 413
- Silicon carbide  
 and nail files, 250
- Silicones, 271
- Silikon 1000®, 371
- Silk'n®, 309
- Silymarin  
 photoprotective effects of, 119
- Skicon®, 281
- Skin  
 action of subcutaneous muscles and, 245  
 aged, and wrinkles, 242  
 anatomical characteristics of, 1, 2  
 biochemical composition of, 1, 3  
 collagen density of, 1  
 color of, 8–9  
 condition of consumers', 283  
 conductance measures of, 8  
 cutaneous microvasculature of, 5–7  
 damaged, 284  
 dry  
 different levels of, 275  
 moisturizers to alleviate, 274–276  
 preventing return of, 276  
 dryness, measuring, 278  
 effects of lotions on, 278–281  
 elasticity of, 281–282  
 electrical properties, measurement of, 181
- [Skin]  
 ethnic differences in  
 aging and rejuvenation, 383–384  
 blood vessel reactivity, 398–399  
 color of, 379  
 corneocyte variability, 398  
 elastic recovery/extensibility, 399  
 epidermal innervation, 401  
 lipid content, 400  
 melanosomes, 395–397  
 overview, 395  
 pH gradient, 399–400  
 photodamage, 401–402  
 sebum content and secretion, 400–401  
 sensitive skin and, 75, 76  
 transepidermal water loss, 397–398  
 vellus hair follicles, 401  
 water content, 398  
 friction coefficient, evaluation of, 183  
 functional differences of, 3, 4  
 hand and body lotions and. *See* Hand and  
 body lotions  
 hormonal influence of, 9–10  
 hydrocolloid masks, 194  
 irritants, 3, 5  
 mechanical properties of, 3, 4  
 melanin in, 269  
 microstructure, spectroscopic methods for  
 evaluating, 278  
 overview, 1  
 pH of, 14–16, 188  
 pigmentation, 190  
 pilosebaceous unit of, 10–11  
 sensory function of, 7–8  
 structural characteristics of, 1, 2  
 surface topography, measuring, 278  
 viscoelastic properties of, assessment of,  
 282  
 vitamin D, 200  
 vitamins A, C and E, 183  
 water content of, measuring, 278–281
- Skin, of men  
 ageing of, 365–366  
 aspects of, 366  
 thickness, 365
- Skin, types of  
 dry skin, 180  
 evaluation methods  
 brightness measurement, 182  
 hydration measurements, 181–182  
 optical coherence tomography (OCT), 181  
 sebum measurement, 182  
 skin surface morphology, 181  
 greasy skin, 180–181  
 normal skin, 180
- Skin aging  
 bimineral complex for. *See* Photoaging,  
 bimineral complex for  
 bioelectricity and, 471  
 and estrogens, 407  
 hormonal, 405–406  
 HRT and, 406  
 and isoflavones, 407  
 of men, 365–366  
 and menopause, 405  
 and phytoestrogens, 407  
 racial differences and, 383–384
- Skin barrier cream efficacy  
 in vitro methods, 47–48  
 in vivo methods, 48–52  
 overview, 47
- Skin cancer, 212  
 chronic UV-induced damage of, 208  
 prevention, 203–204
- Skin capacitance, 505
- Skin care  
 soy, in traditional use of, 128
- Skin care products. *See also* Ancillary skin care  
 products  
 dry skin, care of  
 additives to moisturizer, 184  
 humectant moisturizing, 184  
 occlusive moisturizing, 184  
 greasy skin, care of  
 acne treatment, 185  
 facial washing, 184  
 seborrheic dermatitis treatment, 185  
 sebum regulator, 185  
 normal skin, care of  
 cleansing products, 182  
 hydrating products, 182–183  
 photoprotective products, 183
- Skin-Ceuticals, 207
- Skin color, 505
- Skin diseases  
 plasmin in, 145–146
- Skin hygiene, 195
- Skin hyperpigmentation, 176
- Skin lightening/whitening, 311. *See also*  
 Dyschromia
- Skin physiology tests, 32
- Skin pigmentation, 190  
 bioelectricity and, 473  
 disorders, 176
- Skin properties, characterization of  
 optical techniques for, 538–539
- Skin reflectance spectroscopy, 9
- Skin scale, 194
- Skin sensitization, 169
- Skin surface biopsies (SSB), 48
- Skin surface lipid (SSL), 14  
 content and composition of, 15
- skin wounds, electric currents at, 466
- SLES. *See* Surface evaluation of living skin  
 (SLES)
- SLS. *See* Sodium lauryl sulfate (SLS)
- Smoking  
 and wrinkles, 242
- Social recognition  
 appearance restoration and, 331
- Sodium dodecyl sulfate (SDS). *See* Sodium  
 lauryl sulfate (SLS)
- Sodium lauryl sulfate (SLS), 3, 28, 47, 144
- Sodium morrhuate, 297  
 for sclerotherapy, 297
- Sodium tetradecyl sulfate (STS), 296, 297  
 for sclerotherapy, 297
- Soft tissue augmentation  
 collagen for  
 bovine, 454, 456  
 human, 456  
 porcine, 459  
 historical aspects, 454–455  
 hyaluronic acid, 456–457  
 injection technique, 457  
 treatment with, 457  
 indications, 455–456  
 poly-L-lactic acid for, 455, 459–460  
 polymethylmethacrylate for, 455, 460,  
 461–462  
 adverse effects with, 461–462  
 injection technique, 462
- Soft tissue filling, in men, 370
- Solar keratosis  
 hydroxyacids for, 100
- Solar lentigines  
 and mottled pigmentation, 383  
 treatment of, 319, 321
- Solar lentigo, 500
- Solar ultraviolet radiation, 206  
 components of, 42
- Solid microneedles, 418–419
- Solubility  
 of hydroxyacids, 94

- Solvents, nail varnish, 252
- Sony microdigital meter  
measured nail thickness, 64
- Sorbitan sesquioleate (SSO), 171
- Sotradecol, 294
- Soy and soy-based products  
as depigmenting agent, 312
- Soybean  
composition characteristics, 130  
oil, 127
- Soybean trypsin inhibitor (STI), 128  
for treatment of hyperpigmented lesions, 134
- Soy extract emulsion, 214
- Soy in skin care, application of  
in human health, 127  
overview, 127  
in topical application, 127–128  
traditional use of, 128
- Soy isoflavonoids, 130
- Soy protein, 127  
keratinocyte-melanocyte cocultures treated with, 129
- SPC. *See* Sphingosyl phosphoryl choline (SPC)
- Spectrophotometric measurements, 8
- SPF. *See* Sun protection factor (SPF)
- Sphingosine (S), 152
- Sphingosyl phosphoryl choline (SPC), 156
- Spider telangiectasias, 494
- Spider veins. *See also* Telangiectasia;  
Telangiectatic webs  
treatment of, contraindications to, 295
- Spinal cord injury (SCI), 476
- Split thickness grafting, 316
- Spray-on tanning formulations, 189
- SPT. *See* Serine palmitoyl transferase (SPT)
- Squamometry, 278
- Squamous cell carcinoma (SCC), 43
- SREBP. *See* Sterol regulatory binding proteins (SREBP)
- SSB. *See* Skin surface biopsies (SSB)
- SSL. *See* Skin surface lipid (SSL)
- Stabilizers, nail, 252, 259
- Staining, nails, 255
- Staphylococcus aureus*, 156, 256
- Staphylococcus epidermidis*, 256
- Stasis, vascular  
cryosurgery and, 436
- Stasis dermatitis  
pigmentation due to, treatment of, 322
- Stearalkonium hectorite, 252
- Stereoisomers, 93–94  
of hydroxyacids, 93–94
- Sterilization, nails, 257
- Sterol regulatory binding proteins (SREBP), 157
- STI. *See* Soybean trypsin inhibitor (STI)
- Stick-on nail dressing, 256
- Stimulation  
thermal response to, 7
- Strains  
calculation of, in computer wrinkle model, 245
- Stratum corneum (SC), 150, 181, 269  
adhesion of, 3  
barrier, hydroxyacids and, 95  
“bricks and mortar” structure of, 151  
content and composition of, 15  
homeostasis in, 14  
lipid  
content in, 14, 73  
matrix of, 150  
organization in, 154–155  
low-magnification electron micrograph of human, 151  
permeability and, 73–74  
physical interaction between urokinase, 146–149
- [Stratum corneum (SC)]  
racial differences, 397–398  
in pH, 380  
in structure, 379–380  
in water content, 380  
surface, integrity of, 278
- Stratum corneum sphingolipid, 1
- Streptococcus thermophilus*, 159
- STS. *See* Sodium tetradecyl sulfate (STS)
- Styling gels, 225
- Styling polymers, 224
- Subcutaneous fat  
anatomy of, 290  
layer, 242
- Subcutaneous muscles, action of, skin and, 245, 246
- Sucrose acetate isobutyrate (SAIB), 252
- Sugaring/threading, 307
- Sulfur, for acne, 360–361
- Sunblocks, chemical  
UVA absorbers, 198  
UVB absorbers, 198
- Sunburn, 41
- Sunburn cells (SBC)  
hydroxyacids for, 99  
idebenone and, 112
- Sun-damaged skin  
cryopeels and, 438  
cryosurgery for, 438
- Sun exposure, 494
- Sunglass  
cornea, 202  
excessively dark tinted, 202
- Sun protection, racial differences and, 382
- Sun protection factor (SPF), 41, 183, 200
- Sunscreen product, 183  
organic/inorganic, 200  
photoprotective ability of, 183
- Sunscreens, 206  
for men, 370
- Superficial thrombophlebitis, 299  
postsclerotherapy, 299
- Superficial venous system, anatomy of, 294–295
- Surface evaluation of living skin (SLES), 278
- Surface profile (crow’s-feet area)  
histogram of, 32
- Sweating, in men, 369
- Sycosis barbae, 367
- Symbolism, appearance restoration and, 331
- Syncope, cryosurgery and, 440
- Tactile sensor, 281
- t-AMCHA. *See* Trans-4-(aminomethyl) cyclohexane carboxylic acid (t-AMCHA)
- Tanning product types, 189
- TAPS. *See* Tetracetylphytyosphingosine (TAPS)
- Tattooing-dermopigmentation, 369
- Tattoos  
cryosurgery of, 439, 440  
treatment of, 324
- Tazarotene  
for acne, 358  
as depigmenting agent, 313
- TCA. *See* Trichloroacetic acid (TCA)
- Teflon, 455  
nail forms, 259, 260
- Telangiectasia, 294–300  
on cheek, 495  
classifications of, 494  
epidemiology of, 294  
incidence of, 294  
sclerotherapy for. *See* Sclerotherapy  
treatment of, 295
- Telangiectatic matting, 298  
defined, 298
- Telangiectatic webs  
epidemiology, 294  
historical aspects, 294  
treatment of, sclerotherapy for. *See* Sclerotherapy
- Tenocyte proliferation, METS effects on, 473  
DNA content, 473–474
- TENS. *See* Transcutaneous electrical nerve stimulation (TENS)
- Teosyal<sup>®</sup>, 371
- TEP. *See* Transepithelial potential (TEP)
- Test products, 55  
characteristics of, 56
- Tetracetylphytyosphingosine (TAPS), 158
- TEWL. *See* Transepidermal water loss (TEWL)
- TF. *See* Tosylamide/formaldehyde resin (TF)
- TGF- $\beta$ . *See* Transforming growth factor- $\beta$  (TGF- $\beta$ )
- Thermal sensation, of skin, 7–8
- Thermocouple device, in cryosurgery, 435
- Thermography, 291
- Thermolysis, for hair removal, 307
- Thermoregulation, of human skin, 7
- High circumference, measurement of, 291
- Thimble-shaped finger cover, 261
- Thioctic acid ( $\alpha$ -lipoic acid), as depigmenting agent, 313
- Thiol antioxidants, photoprotective effects of, 119
- Third circulation theory, 412
- Thixotropic systems, 252
- Thrombophlebitis, superficial,  
postsclerotherapy, 299
- Thyroid-stimulating hormone (TSH), 10
- Timed spot freeze technique, cryosurgery, 434–435
- Time Off Nail, 64
- Tissue engineering, biomimetic electricity in, 475
- Tissue hypoxia, 290
- Tissue injury, cryosurgery and, 436
- TLCK. *See* Tosyl-lysine chloromethyl ketone (TLCK)
- Tocopherols, 115–116, 118, 207  
molecular structures of, 208
- Toluenesulfonamide/formaldehyde resin (TSFR), 251
- Tone-on tone coloring, 368
- Top coats, nails, 253
- Topical eflornithine cream, for excessive hair treatment, 307–308
- Topical estrogens, photoaging, correction of, 214
- Topical 5-fluorouracil (5-FU)  
for actinic keratosis, 429–432  
comparison of trials/methods, 429–430  
0.5% 5-FU, 430  
1% 5-FU, 430  
5% 5-FU, 430  
history of, 429  
limitations of, 432  
side effects of, 430–432
- Topical 5-FU. *See* Topical 5-fluorouracil (5-FU)
- Topical L-selenomethionine, 211
- Topical preparations, selenium sulfide, 211
- Tosylamide/formaldehyde resin (TF), 251
- Tosyl-lysine chloromethyl ketone (TLCK), 144
- Total soy  
anti-inflammatory activities in, 133  
antioxidant activities, 133  
antistress/thiol retention activity, 133  
clinical efficacy of, 134–138  
acnic inflammatory lesions, 136–137  
delay in hair regrowth, 135–136  
ethnic skin, effects on, 137–138

- [Total soy  
 clinical efficacy of]  
 fade facial lentiginosities, 135  
 hyperpigmentation, 134  
 sebum production of, 137  
 skin firming of, 137  
 ultraviolet-induced damages, reduction of, 134–135  
 UVA/UVB protection, 135  
 collagen production of, 132  
 components with potential applications in skin care, 131  
 for cosmetic dermatology applications, 129–134  
 delayed hair growth and, 128–129  
 elastin enhancement in, 132–133  
 extracellular collagen synthesis in normal human dermal fibroblasts, 132  
 in vitro and preclinical results of, 132–134  
 safety for human topical applications, 131–132  
 scientific advances in, 128–129  
 thiol retention activity measurement for, 133  
 trypsin-inhibitory activity of, 132  
 tRA. *See* Trans-retinoic acid (tRA)  
*Traditional Chinese Medicine Encyclopedia*, 127  
 Tranexamic acid, as depigmenting agent, 313  
 Tranexamic acid cetyl ester hydrochloride, as depigmenting agent, 313  
 Trans-4-(aminomethyl)cyclohexane carboxylic acid (t-AMCHA), 144, 146–149  
 improvement of skin surface texture after, 149  
 molecular structures of, 148  
 Transcutaneous electrical nerve stimulation (TENS), 466, 467  
 Transcutaneous electrotherapy, 467  
 Transcutaneous oxygen pressure, 7  
 Transepidermal water loss (TEWL), 14, 16, 49, 144, 276, 379–380, 505  
 measurement of, 181  
 Transepithelial potential (TEP), 468  
 Transforming growth factor- $\beta$  (TGF- $\beta$ ), 342  
 Transillumination, 295  
 Trans-retinoic acid (tRA), 106  
 Transverse breaking, nails, 248, 249  
 Tretinoin  
 for acne, 354  
 as depigmenting agent, 313  
 TriActive, 292  
 Triamcinolone acetone, 346  
 Trichloroacetic acid (TCA), 489–491  
 for basal layer peeling, 484  
 for grenz zone peeling, 485  
 for intraepidermic peeling, 482–483  
 for papillary dermis, 485–486  
 for reticular dermis peeling, 486–487  
*Trichophyton mentagrophytes*, 476  
*Trichophyton rubrum*, 476  
 TrichoScan, 512  
 Triglycerides, 271  
 Trimming of hair, 306–307  
 Tripollar RF device, 293  
 TRP-1. *See* Tyrosinase-related protein 1 (TRP-1)  
 TSFR. *See* Toluenesulfonamide/formaldehyde resin (TSFR)  
 TSH. *See* Thyroid-stimulating hormone (TSH)  
 Tumor necrosis factor (TNF), 210  
 Tumor progression, hyaluronan in, 85  
 Two test protocols  
 comparison of, 58–61  
 efficiency of lotion transfer for, 60  
 Tyrosinase-related protein 1 (TRP-1), 477  
 Tyrosine protein kinases (TPKs), 212  
 Ulcer, postsclerotherapy, 298–299  
 Ultralow intensity electricity therapy, 467  
 Ultrasonography, and cellulite, 291  
 Ultraviolet exposure  
 skin blood flow volume, 507  
 skin capacitance, 508  
 skin color, 507  
 topical emulsion, antioxidative capacity, 505  
 analysis of, 508  
 $a^*$  values, 506, 507  
 BFV, 506, 507  
 minimal erythema dose (MED), determination of, 505  
 skin capacitance, 508  
 skin response, evaluation of, 505–506  
 TEWL, 506  
 treatment, 506  
 Ultraviolet-induced damages, reduction of, 134–135  
 Ultraviolet radiation (UVR), 180, 183, 503, 505  
 acute effects of, 41–43  
 immunosuppression, 42  
 UV-induced erythema, 41  
 UV-induced pigmentation, 41–42  
 vitamin D synthesis, 42  
 chronic effects of, 43  
 photoaging, 43  
 photocarcinogenesis, 43  
 effect on antioxidants, 117  
 exposure, 509  
 photoaging, 87  
 ROS formation and, 115  
 sunscreens, 197  
 Ultraviolet (UV) light, 41, 252, 506  
 artificial nails and, 261  
 hand and body lotions ingredients and, 287  
 United States  
 leading hand and body lotions in, 270  
 Universal congenital hypertrichosis, 305  
 Univinil T 150, 201  
 Unsaturated fatty acids, as depigmenting agent, 314  
 uPA. *See* Pro-urokinase plasminogen activator (uPA)  
 Upper face, botulinum toxin (BT) for, 444–446  
 crow's feet lines, 446  
 forehead lines, 446  
 glabellar lines, 445–446  
 Urea, 184  
 Urokinase  
 activation in the stratum corneum of dry skin, 146  
 in dry skin, 146  
 overview, 144  
 physical interaction between stratum corneum, 146–149  
 Urticaria, recurrent, 255  
 UV. *See* Ultraviolet (UV)  
 Uvasorb HEB, 201  
 UVB-induced skin damages  
 reduction in, 133–134  
 Uvederm® Ultra, 371  
 UV gels, 262–263. *See also* Light-curing gels  
 adverse reactions of, 263–264  
 colored, 263  
 removable, 263  
 removal, 263  
 UV-induced erythema, 41  
 timeline of, 42  
 UV-induced pigmentation, 41  
 problems, 494  
 timeline of, 42  
 UV-induced skin cancers, 212  
 UVR. *See* Ultraviolet radiation (UVR)  
 UVR-induced immunosuppression, 42  
 Vaginal atrophy, menopause and, 407  
 Vaginal dryness, menopause and, 407  
 Vaniqa®, 308  
 Van Scott's research, 197  
 Varicose veins, 294–300  
 ambulatory phlebectomy for, 299, 300  
 endovenous occlusion techniques for, 299  
 epidemiology, 294  
 historical aspects, 294  
 incidence of, 294  
 lasers and light sources for, 300  
 sclerotherapy for. *See* Sclerotherapy  
 surgical approaches for, 299–300  
 ambulatory phlebectomy, 299–300  
 endovenous occlusion techniques, 299  
 lasers and light sources, 300  
 surgical ligation and limited stripping, 299  
 Varnishes, nail  
 formulation, 251–253  
 color additives, 252–253  
 film former, 251  
 film modifier, 251–252  
 plasticizers, 252  
 solvents and diluents, 252  
 stabilizers, 252  
 viscosity modifiers, 252  
 VAS. *See* Visual analogues scale (VAS)  
 Vascular endothelial growth factor (VEGF), 510  
 Vascular lesions, cryosurgery of, 436–438  
 Vascular occlusion, cryosurgery and, 436  
 Vascular stasis, cryosurgery and, 436  
 Vasodilatation, 5  
 Vasospastic diseases, 5  
 Velasmoor, 292  
 Vellus hair, ethnic differences in, 392–393  
 Vellus hair follicles, ethnic differences in, 401  
 Verrucae vulgares  
 hydroxyacids for, 98–99  
 Very long-chain fatty acids (VLCFA), 153  
 Vinyl masks, 194  
 Viral warts  
 cryosurgery of, 438  
 types, 438  
 common, 438  
 digital, 438  
 filiform, 438  
 plane, 438  
 verrucas, 438  
 Viscosity modifiers, 252  
 Visible light, cutaneous effects of, 43–44  
 erythema, 44  
 pigmentation, 44  
 ROS formation, 44  
 Visioscan VC98 device, 181  
 Visual analogues scale (VAS), 475  
 Visual scores (VS), 505  
 Vitamin A. *See* Retinol  
 Vitamin C, 206, 413  
 photoaging, correction of, 207  
 photoprotective effects of, 118  
 solar damage protection, 206  
 Vitamin D synthesis, 42  
 Vitamin E, 207, 208  
 antioxidant activity of, 503  
 emulsion, 506, 508  
 photoprotective effects of, 118  
 Vitiligo, treatment of, 317, 319, 320  
 Vivascope 1500, 181  
 VLCFA. *See* Very long-chain fatty acids (VLCFA)  
 Vulvar atrophy, menopause and, 407  
 Warts  
 hydroxyacids and, 98–99  
 viral, cryosurgery and, 438  
 Washing products, for men, 369

- Washing test  
  on bend of the elbow, 33
- Water  
  as ingredient, for hand and body lotion, 270  
  structure, in skin, 20–22, 23
- Water-based nail varnishes, 253–254
- Water-based styling polymers, 225
- Water content, of skin  
  ethnic differences in, 398  
  measurement of, 278–281
- Water-in-oil (W/O) emulsions, 273, 274
- Water loss, transepidermal  
  ethnic differences in, 397–398
- Water-soluble polymers  
  as ingredient, for hand and body lotion, 272
- Wavelength, components of, 42
- Wax-based face masks, 194
- Waxes, 226
- Waxing, 307
- Weathering, hair displaying signs of, 220
- Westerhof formula, for depigmentation, 314
- Wettability, measurement of, 181
- Whitener, nail, 251
- Window glasses, types of, 203
- Winter xerosis, environmental factors on, 156–157
- W/O emulsions. *See* Water-in-oil (W/O) emulsions
- Wool wax, 270
- Wounds  
  and bioelectricity, 469–471  
    healing, 468, 471, 474–475  
  healing  
    hyaluronan in, 86
- Wrapping, of nails, 264–265, 266
- Wrinkles  
  aged skin and, 242  
  AHAs for, 100  
  collagen fibers and, 242, 243, 244  
  décolleté, botulinum toxin (BT) for, 449, 450
- [Wrinkles]  
  fibroblasts and, 245–246  
  local differences in, 242–243  
  overview of, 242  
  periorbital. *See* Periorbital wrinkles  
  phenol peelings for, 492  
  smoking and, 242  
  treatment of, 246
- Xanthoderma, defined, 311
- X-ray spectroscopy, 154
- Zinc oxide/petrolatum (ZnO/Pet), 54
- ZnO/Pet. *See* Zinc oxide/petrolatum (ZnO/Pet)
- Zyderm I, 456
- Zyderm II, 456
- Zyderm Zyplast<sup>®</sup>, 370
- Zyplast, 456

# TEXTBOOK OF COSMETIC DERMATOLOGY

FOURTH EDITION

## About the editors:

ROBERT BARAN, MD, is a Dermatologist at the Nail Disease Center, Cannes, France. He is also the editor of *Handbook of Cosmetic Skin Care 2E*, *The Nail in Differential Diagnosis*, *Onychomycosis 2E*, and *Text Atlas of Nail Disorders 3E*, amongst many others.

HOWARD I. MAIBACH, MD, is Professor of Dermatology at the University of California School of Medicine, San Francisco, California, USA. He is also the editor of *Handbook of Cosmetic Science and Technology 3E*, *Marzulli and Maibach's Dermatotoxicology 7E*, and *Cosmeceuticals and Active Cosmetics 2E*, amongst many others.

## About the book:

This text documents the science that lies behind the expanding field of cosmetic dermatology so that clinicians can practice with confidence and researchers can be fully aware of the clinical implications of their work. New chapters have been added on the latest modalities and topics of interest, such as mesotherapy and bioelectricity, to keep this at the forefront of work and practice.

## From reviews of previous editions

“ This is undoubtedly my dermatology “book of the year”. I would recommend all to browse through it, but beware, you may still be reading two hours later ”

*The Lancet*

The Series in Cosmetic and Laser Therapy is published in association with the *Journal of Cosmetic and Laser Therapy*

**informa**  
healthcare

Telephone House, 69-77 Paul Street, London EC2A 4LQ, UK  
52 Vanderbilt Avenue, New York, NY 10017, USA

[www.informahealthcare.com](http://www.informahealthcare.com)

